

In honor of
The Explosives and Weapons Forum

We present:
The Encyclopedia of Explosives and Related Items

PATR 2700, the Encyclopedia, Federoff, the Bible of Explosives, call it what you will as it has many names. There are few enough books in existence that cover a topic such as explosives, let alone do such a good job as to be a must have reference for anyone in the field. The Encyclopedia is the single greatest work on explosives period. Get it, copy it, distribute it far and wide.
A special thanks goes to megalomania for creating The Forum, to NBK2000 for keeping out the kewls, and to nhamilto40 for ripping the original of this book.



<http://www.roguesci.org>

All the knowledge “they” don’t want you to have

Visit The Forum at <http://www.roguesci.org/theforum/index.php>

Visit the Chem Lab at <http://www.roguesci.org/megalomania>

ENCYCLOPEDIA OF EXPLOSIVES AND RELATED ITEMS

PATR 2700

VOLUME 4

BY

BASIL T. FEDOROFF & OLIVER E. SHEFFIELD



U.S. ARMY RESEARCH AND DEVELOPMENT COMMAND
TACOM, ARDEC
WARHEADS, ENERGETICS AND COMBAT SUPPORT CENTER
PICATINNY ARSENAL
NEW JERSEY, USA

1969

Copies of the "Encyclopedia of Explosives
And Related Items" can be obtained by requesting CD ROM
from the:

National Technical Information Service
(formerly Clearinghouse)
US Department of Commerce
Springfield, Virginia 22151

1-800-553-6847 USA only
703-605-6000
www.ntis.gov/FCPC

The contents of these volumes are UNCLASSIFIED

The distribution of these volumes is UNLIMITED

Neither the US Government nor any person acting on behalf of
the US Government assumes any liability resulting from the use or
publication of the information contained in this document or warrants
that such use or publication will be free from privately owned rights.

All rights reserved. This document, or parts thereof, may not be
reproduced in any form without written permission of the
Energetics and Warhead Division, WECAC, TACOM, ARDEC, Picatinny Arsenal

Library of Congress Catalogue Card Number: 61-61759

PREFACE

This volume represents a continuing effort to cover comprehensively the unclassified information on explosives and related subjects in the same manner & format as in previous volumes. The reader is urged to obtain the previous volumes and to read both the PREFACE & INTRODUCTION in Volume 1 in order to understand the authors' way of presenting the subject matter

In the preparation for and the writing of this Encyclopedia, the authors have consulted freely with and have had the cooperation of many individuals who have contributed their expert knowledge. This fact is acknowledged throughout the text at the end of the subject item. Mr John F. W. Pflueger, former Picatinny Arsenal engineer now located at the Letterkenny Army Depot at Chambersburg, Pennsylvania, called to our attention or supplied us with many of the latest technical manuals & other publications related to explosives & ammunition. A listing of many others who have helped in various ways would be impractical

Mr L.H. Eriksen, Feltman Research Laboratories Director, Picatinny Arsenal, has authorized & approved this project. It is thru his interest, encouragement & guidance that this publication is possible. The support of this project by Dr J.V.R. Kaufman, US Army Material Command Deputy Director for Plans, AMCRD, is also gratefully acknowledged. This Encyclopedia was prepared by scientists assigned to the Explosives Laboratory of FRL, Dr R.F. Walker, Chief. All reference works used, such as reports, periodicals, journal & books, were made available thru the cooperation of the Scientific & Technical Information Branch personnel, Mr M.A. Costello, Chief

Although considerable effort has been made to present this information as accurately as possible, mistakes & errors in transcription & translation do occur. Therefore, the authors encourage the readers to feel free to point out mistakes, errors & omissions of important works so that corrections & additions can be listed in the next volume. The interpretations of data & opinions expressed are often those of the authors and are not necessarily those nor the responsibility of officials of Picatinny Arsenal or the Department of the Army

This report has been prepared for information purposes only and neither Picatinny Arsenal nor the Department of the Army shall be responsible for any events or decisions arising from the use of any information contained herein



Errata in Volume 1

| | |
|-------------------------------------|--|
| p IX, 10th line from bottom | Change "under C" to under Berthelot's Characteristic Product, p B105 |
| p XX, 2nd line from bottom | Produit caractéristique instead of Produit Characteristique |
| p Abbr 13-R | DA direct (instead of direction) action (Brit) for point detonating fuze, superquick |
| p Abbr 74, 10th line from top | Feigenspan instead of Feignespan |
| p Abbr 75, 10th line from top | (URSS) instead of (USSR) |
| p Abbr 75, 15th line from top | DoklAkad N Replace Sec etc with: Listed sometimes in CA and in some other sources as CompRendAcadSci (URSS) |
| p A252-R, 11th line | -1,2-propanediol Dinitrate instead of 1,3-propanediol Dinitrate |
| p A311-R, 1st to 3rd lines from top | should read: The heat of transition from form III to form II is 310 cal/mol and that from form II to I is 979 cal/mol. |
| p A457-L, 10th line | ANISYLTETRAZOLE instead of ANISLYTETRAZOLE |
| p A-479-L, last line | Asphaltines instead of Asphaltenes |
| p A522-R | Arsenic Triazide, mw 200.98, N 60.00% |
| p A523-L, 2nd line | Barium Diazide, mw 221.41, N 38.00% |
| p A531-L | Cobalt Diazide or Cobalt Dinitride instead of Cobalt Triazide |
| p A544-L | Lanthanum Triazide, mw 264.99, N 47.58% |
| p A574, first equation | should read: $2 \text{Ce}(\text{SO}_4)_2 + 2\text{NaN}_3 \rightarrow 3\text{N}_2 + \text{Na}_2\text{SO}_4 + \text{Ce}_2(\text{SO}_4)_3$ |
| p A574, paragraph XVI | should read: Disperse with stirring ca 1 oz of waste LA in 1.5 gal 10% aq Amm acetate soln, add 2.5 oz of Na nitrite - - - |
| p A586-L, 10th line | Insert Tetracene after Lead Azide |
| p A642-R | 1 - Azidopseudocumene See 2,4-Dimethyl benzylazide and Beil 5, 405, (199) instead of: See under Pseudocumene |
| P A659-R, 18th line | 5, 5' - Dinitro-o-azostilbene instead of 5, 5' - Dinitro-o-stilbene |

Errata in Volume 2

| | |
|------------------------------------|---|
| p B92-L, 20th line | mw 244.13 (instead of 243.13), N17.22% (instead of 17.28%) and OB to CO ₂ -62.3% (instead of -62.5%) |
| p B122-R 11th line from the bottom | Delete the word <i>Di phenyl</i> in the Title |
| p B135-R, 21st line | p-Nitrol-1,1,4,4-tetra- instead of p-Nitrol, 1,4,4-tetra - |

Errata in Volume 2 (Cont'd)

| | |
|------------------------------------|--|
| p B151-R, 3rd line from the bottom | 1,2-Bis (2-nitrimino- , etc instead of 1,2-Bis (2-nitramino - etc |
| p B155-L, 16th line | Di(picrylthiol)-xylene instead of Di(picrylthiol)-zylene |
| p B258-L | Boulangé, Le Chronograph instead of Boulengé, Le Chronograph |
| p B357-R, 4th line | propants) instead of explns) |
| p C202-L, Line 16 from bottom | deflagrated instead of detonated (suggested by Dr Herbert Ellein) |

Errata in Volume 3

| | |
|------------------------------------|---|
| p XII | Carpio 1 (1948) should read: Caprio 1 (1948) Carpio 2 (1949) Caprio 2 (1949) C. Caprio, "Corso di Esplosivi", etc |
| p XIII | Urbański (Vol & Year) should read: Urbański, Vol 3 (1967), 717 pp |
| p C306-R | <i>Boulangé (Le) Screen</i> instead of <i>Boulengé (Le) Screen</i> |
| p C307-R | <i>Boulangé (Le) Chronograph</i> instead of <i>Boulengé (Le) Chronograph</i> |
| p C307-R, 5th Line from the bottom | Le Boulangé Chronograph instead of Le Boulengé Chronograph. |
| p C308-L in two places | Le Boulangé instead of Le Boulengé |
| p C446-R, 9th line | <i>sécurité</i> instead of <i>secûrite</i> |
| p C607-L | Solubility of HMX in Nitroethane should read 0.3 g/100 ml of soln instead of 0.03 |
| p C630-L | should read: Cyclotrimethylene-trinitramine (Cyclonite) Homolog |
| p D44-L, 5th line from top | nitronium instead of nitromium |

TABLE OF CONTENTS

| | Page |
|---|-------|
| Preface | I |
| Errata in Volumes 1, 2 & 3 | III |
| List of Figures and Illustrations | XXI |
| Supplement to Abbreviations, Code Names and Symbols | XXXIX |
| Supplement to Abbreviations for Books and Periodicals | XLVII |
| Supplement to the List of Books on Explosives and Propellants | LI |
| DETONATION, EXPLOSION AND RELATED SUBJECTS | |
| Section 1. Subjects Related to Detonation (and Explosion) | D137 |
| Aeration of Explosives | D138 |
| Air Gap Sensitiveness to Detonation (and Explosion) | D139 |
| Annular Detonation Wave | D139 |
| Anomalous High Velocity of Detonation | D139 |
| Axial Initiation of Multi-Component Explosive Charges | D140 |
| Backward Detonation and Retonation | D143 |
| Backward Wave Propagation | D143 |
| Ball Lightning Explosion | D143 |
| Barrier Tests and Their Comparison with Shooting Tests | D145 |
| Blast Contours | D148 |
| Blast, Spherical | D149 |
| Boltzmann Constant | D149 |
| Brisance (or Shattering Effect) | D149 |
| Brisance, Correlation with Chemical Structure | D150 |
| Brisance, Correlation with Properties Other Than Chemical | D150 |
| Brisance, Determination by Method of Metal Acceleration by Explosives | D150 |
| Bullet Impact Sensitivity of Explosives | D153 |
| Burning (Combustion) and Deflagration of Gases Vapors and Dusts | D154 |
| Burning, Propagative | D163 |
| Burning Rates of Condensed Explosives | D163 |
| Burning Rates of Explosive Mixtures with Air or Gases, Vapors and Dusts | D164 |
| Burning Rates of Propellants for Artillery Weapons | D164 |
| Burning Rates of Propellants for Rockets | D165 |
| Burning Rates of Propellants; Experimental Techniques | D165 |
| Burning Rates of Pyrotechnic Compositions | D165 |
| Calorimetric Measurements in Combustion, Deflagration, Explosion, and Detonation | D166 |
| Cavitation Phenomenon | D167 |

| Section 1. Subjects Related to Detonation (and Explosion) (Cont'd) | Page |
|---|------|
| Characteristic Direction | D169 |
| Charge Parameters in Detonation (and Explosion) | D170 |
| Combustion | D170 |
| Combustion, Explosion, and Shock Waves | D172 |
| Combustion Kinetics, Importance in Rocket Propellants of | D172 |
| Combustion Knock | D172 |
| Combustion of Propellants for Rockets | D173 |
| Combustion (Flame) Temperature of Explosives; Measurements | D175 |
| Combustion (Flame) Temperature of Propellants; Measurements | D175 |
| Computers and Computer Programs | D176 |
| Computer Program for a Digital Computer | D179 |
| Computer Program for an Analog Computer | D179 |
| Condensed Phases, Testing | D186 |
| Contact Detonation Sensitivity Test | D186 |
| Contact Transmission of Detonation | D187 |
| Contrasting Patterns in the Behavior of High Explosives | D190 |
| Corresponding States, Law of | D194 |
| Covolume | D196 |
| Covolume and the Condition of Gases of Decomposition in the Detonation Zone of Brisant Explosives | D196 |
| Criterion of Explosiveness | D196 |
| Critical Diameter of Liquid Explosives | D197 |
| Critical Diameter of Solid Explosives | D198 |
| Critical Energy of Impact (or Shock) in Detonation (or Explosion) | D198 |
| Critical Length of Propagation of Detonation | D199 |
| Critical Mass of Explosives | D201 |
| Critical Phenomenon | D201 |
| Critical Point | D201 |
| Critical Pressure Value | D202 |
| Curvature of Wave Fronts | D202 |
| Cybernetics | D203 |
| Cylindrical Detonations | D203 |
| Decomposition, Thermal of Explosives and Propellants Influence of Pressure and Temperature | D204 |
| Deflagrating Explosives | D207 |
| Deflagration | D207 |
| Development (Transition) from Combustion (Burning) of Explosives and Propellants in Powdered Explosives | D207 |
| Deflagration Point of Graphite Oxide | D208 |
| Deformation and Break-Up of Solids by Detonation (and Explosion) | D208 |
| Delayed-, After-, or Post-Reactions in Detonation | D210 |
| Detonability and Flammability of Explosives, Propellants and Pyrotechnic Compositions | D211 |
| Detonating Capacity of Explosives, Effect of Various Factors | D213 |

| | Page |
|--|----------------------|
| Section 2. Detonation, Explosion and Explosives | D217 |
| Introduction and Definitions | D217 |
| Detonation and Explosion | D223 |
| Detonation; Attenuation, Break, Cessation, Cutoff, Decay, Dying-Out, Extinction, Fadeout and Failure | D223 |
| Detonation (and Explosion), Autocatalytic | D225 |
| Detonation; BMPT (Birkhoff-MacDougall-Pough-Taylor) Theory of Jet Formation in Shaped Charges | D226 |
| Detonation (and Explosion), Break Character of Breaking Theory of Carl | D227 |
| Chain Reactions in | D229 |
| Detonation, Chapman-Jouguet (CJ) Condition | D230 |
| Chapman-Jouguet (and Deflagration) | D230 |
| Chapman-Jouguet (in Gas) | D230 |
| Chapman-Jouguet Isentrope | D230 |
| Chapman-Jouguet Parameters or Variables | D230 |
| Chapman-Jouguet Point | D231 |
| Chapman-Jouguet Postulate or Hypothesis | D231 |
| Chapman-Jouguet Pressure | D231 |
| Chapman-Jouguet State | D235 |
| Chapman-Jouguet Theory | D235 |
| Chapman-Jouguet Wave and Flow Behind it | D236 |
| Detonation, Classical Theory of Plane Detonation Wave | D237 |
| Detonation (and Explosion) of Composite Explosives of Composite Propellants-Theoretical Treatment of Condensed (Liquid and Solid) Explosives | D237 D238 D238 |
| Detonation (and Explosion), Craters in | D242 |
| Detonation, Curved Front Theory of Eyring et al | D242 |
| Detonation of Cylindrical Charges | D244 |
| Detonation of Dense Heterogeneous Explosives, Transitional Events Leading to | D245 |
| Detonation (and Explosion) Development (Transition) from Burning (Combustion) or Deflagration | D245 |
| Detonation (and Explosion), Distant Effect of | D252 |
| Detonation and Explosion of Dusts, Mists and Vapors | D253 |
| Detonation (and Explosion), Effects of Blast and Shock Waves on Structures | D256 |
| Effects Produced in Air, Earth and Water | D257 |
| Electrical, Electromagnetic and Magnetic Effects Accompanying it | D258 |
| Detonation, End Effect in | D264 |
| Detonation (and Explosion), Energy of | D264 |
| Energy Relationships in | D266 |
| Energy (Relative) Release During Susan Test for Ignition of Explosives by Impact | D266 |
| Enthalpy, Excess in | D267 |

| | Page |
|---|------|
| Section 3. Detonation (and Explosion), Equations of State in | |
| (and Some Other Equations) | D268 |
| Introduction | D268 |
| Equations of State Applicable to Detonation | D270 |
| Products of Condensed Explosives | |
| List of Equations of State | |
| Abel | D271 |
| Allan & Lambourn | D271 |
| Beattie - Bridgeman | D271 |
| Becker | D272 |
| Becker - Kistiakowsky - Wilson | D272 |
| Benedict - Webb - Rubin | D274 |
| Berthelot | D274 |
| Boltzmann | D274 |
| Brinkley - Wilson | D274 |
| Caldirola & Paterson | D274 |
| Callendar | D274 |
| Clausius | D274 |
| Constant- β & Constant- γ | D274 |
| Corner | D276 |
| Cottrell - Paterson | D276 |
| Covolume | D276 |
| Deal Polytropic | D276 |
| Dieterici | D276 |
| Eyring | D277 |
| Fickett | D277 |
| Furth | D277 |
| General | D277 |
| Grüneisen | D278 |
| Halford - Kistiakowsky - Wilson | D278 |
| Hirschfelder & Roseveare | D278 |
| Hirschfelder - Stevenson - Eyring | D278 |
| Hugoniot and Rankine-Hugoniot | D278 |
| Intermolecular Potentials | D281 |
| Joffe | D282 |
| Jones and Jones-Miller | D283 |
| Keyes | D283 |
| Kihara & Hikita | D283 |
| Kistiakowsky-Halford-Wilson-Brinkley | D283 |
| Kistiakowsky - Wilson | D284 |
| Kury | D284 |
| Landau - Stanyukovich | D285 |
| Landau-Stanyukovich-Zel'dovich-Kompaneets | D285 |
| Lees | D287 |
| Lennard - Jones & Devonshire | D287 |
| Lorentz | D288 |
| Macleod | D288 |
| Maron and Turnbull | D288 |
| Mayer & Careri | D289 |

| | Page |
|---|-------------|
| Section 3. Detonation (and Explosion), Equations of State in (Cont'd) | |
| Mie - Grüneisen and Grüneisen | D289 |
| Murgai | D290 |
| Nobel - Abel | D290 |
| Plank | D290 |
| Polytropic | D290 |
| Rankine - Hugoniot | D291 |
| Skidmore & Hart | D291 |
| Su & Chang | D293 |
| Van der Waals | D293 |
| Virial | D293 |
| Wilkins | D294 |
| Wohl | D295 |
| Zel'dovich & Kompaneets | D295 |
| Detonation (and Explosion), Experimental Data Interpretation of | D299 |
| Section 4. Detonation (and Explosion), Experimental Procedures | D299 |
| Detonation of Explosive Mixture | D346 |
| Detonation and Explosives Phenomena | D346 |
| Detonation, Factors Influencing Velocity and other Properties of Explosives in | D347 |
| Detonation, Failure of Coal-Mining Explosives in a Bore Hole | D347 |
| Detonation, Fanno Line | D348 |
| Detonation, Flame Reactions and | D348 |
| Detonation, Flash-Across, Heat Pulse and Hyper-velocity Phenomena | D348 |
| Detonation, Free Volume Theory of the Liquid State Developed by Eyring et al and by Lennard-Jones -Devonshire | D349 |
| Detonation, Free Volume Theory of Multicomponent Fluid Mixtures | D349 |
| Detonation, Front, Non-Planar | D349 |
| Detonation Front and Shock Front. Detonation Zone and Shock Zone | D350 |
| Detonation (and Explosion), Fugacity of Products of | D351 |
| Detonation (and Explosion) in Gases; Determination of Ignition Points | D351 |
| Detonation (and Explosion) in Gases, Vapors and Dusts; Development (Transition) from Burning (Combustion) or Deflagration | D360 |
| Detonation, Geometrical Model Theory of | D363 |
| Detonation in Granular Explosives | D365 |
| Detonation (and Explosion), Hazards (Dangers) of | D366 |
| Detonation, Heat Sensitization of Explosives and Memory Effect | D367 |
| Section 5. Detonation (Explosion, Deflagration, Combustion and Formation), Heats of | |
| Heat of Formation | D369 |
| Heat of Combustion | D370 |
| Heat of Explosion | D375 |

| Section 5. Detonation (Explosion, Deflagration, Combustion and Formation), Heats of (Cont'd) | Page |
|--|-------------|
| Heat of Detonation | D375 |
| Experimental Determinations of Heat of Explosion and Heat of Detonation | D377 |
| Detonation; High-Low- and Intermediate Order, Velocities of | D384 |
| Detonation, Ideal and Nonideal | D389 |
| Detonation (and Explosion), Ignition of Explosives and Propellants to | D390 |
| Detonation (and Explosion) by Impact (or Shock) | D391 |
| Detonation (and Explosion), Impetus and Available Energy | D391 |
| Detonation (and Explosion), Impulse in | D393 |
| Impulse, Specific | D394 |
| Induction Period in Initiation of Explosives and Propellants | D394 |
| Section 6. Detonation (and Explosion) By Influence or Sympathetic Detonation | D395 |
| Booster - Gap Explosive Sensitivity Test of Cole & Edwards | D398 |
| Booster Sensitivity Test | D398 |
| Card-Gap Sensitivity Test of Cook et al | D398 |
| Card Test | D399 |
| Coefficient de self-excitation (CSE) | D399 |
| Four-Cartridge Test | D399 |
| Gap Test | D399 |
| Halved-Cartridge Gap Method | D399 |
| Shock-Pass-Heat-Filter (SPHF) Sensitivity Test | D399 |
| Three-Legged Table Sensitivity Test | D399 |
| Wax Gap Test | D399 |
| Whole-Cartridge Sensitivity Test | D399 |
| Section 7. Detonation (and Explosion), Initiation (Birth), and Propagation (Growth or Spread) in Explosive Substances | D402 |
| Initiation & Shock Processes, Detonation Head and Detonation Edge | D417 |
| Detonation, Jetting in | D420 |
| Detonation, Jumping | D421 |
| Detonation of Large Amounts of Explosives | D421 |
| Lateral Expansion (Dispersion) and Lateral Loss in | D421 |
| Lateral Shock Pressure Measurements at an Explosive Column | D423 |
| Detonation Limit | D423 |
| Detonation Limits in Composite Explosives | D423 |
| Detonation Limits in Condensed Explosives | D424 |
| Detonation Limits in High Explosives | D424 |
| Luminosity (Luminescence) Produced on | D425 |
| Detonation, Mach Number in | D434 |
| Detonation, Mach Wave; Mach Reflection; Triple Point; and Mach Region | D434 |

| Section 7. Detonation (and Explosion), Initiation (Birth), and Propagation (Growth or Spread) in Explosive Substances (Cont'd) | Page |
|---|-------------|
| Detonation, Maser and Laser in | D436 |
| Mechanical Effects of Detonation | D441 |
| Mechanisms of Detonation | D441 |
| Detonation (and Explosion) in a Medium of Variable Density | D441 |
| Model of Von Neumann - Zel'dovich | D442 |
| Molecular Theory of Detonation | D442 |
| Monroe-Neumann Effect (or Shaped Charge Effect) and Lined Cavity Effect in Detonation | D442 |
| NDZ (Neumann-Döring-Zel'dovich) Theory | D454 |
| Neumann's Pathological Detonation | D457 |
| Nonlinear Theory of Unstable One-Dimensional Detonation | D460 |
| Nonreactive Shock in Detonation | D460 |
| Nozzle Theory or Expanding Jet Theory of Jones | D460 |
| Nuclear Detonation (and) Explosion | D461 |
| Oblique Impact of a Layer of Explosive by a Metal Plate | D461 |
| Overboosting in Detonation | D462 |
| Parameters and Characteristics of Detonation | D463 |
| Particle Size Effect in Detonation | D465 |
| Particle Size Effect on Velocity of Detonation | D466 |
| Particle Velocity in Detonation and Its Determination | D466 |
| Penetrating or Jet-Piercing Theory of Apin | D467 |
| Detonation Performance and Its Prediction | D470 |
| Perturbation Theories of Detonation | D470 |
| Phenomena Accompanying Detonation (and Explosion) | D471 |
| Plasma in Detonation | D471 |
| Polytropic Curve and Polytropic Law | D474 |
| Detonation of Powdery Explosive Charges | D475 |
| Power, Available Energy and Strength in Detonation | D476 |
| Precursor Shock in Detonation | D479 |
| Pre detonation Phase in Detonation | D482 |
| | |
| Section 8. Detonation (and Explosion), Pressures of and Their Measurements | |
| Experimental Determination of Pressures Developed on Detonation | D485 |
| Detonation Pressure - Charge Density Relationship and Temperature of Detonation - Charge Density Relationship | D491 |
| Detonation (and Explosion) by Priming and Boosting | D494 |
| Detonation Processes; Properties of Explosives Affecting Them | D494 |
| Detonation (and Explosion) Products | D494 |
| Detonation-Product Equation of State Obtained from Hydrodynamic Data | D495 |
| Detonation Progress Thru a Column of Explosive | D495 |
| Propagation Through Explosive Charges | D497 |
| Propagation Through Layers of Non-Explosive Substances Between Explosive Pellets | D498 |
| Pseudo Detonation | D499 |
| Pseudopotential Theories of Detonation | D499 |
| Qualitative Theory of Detonation | D499 |
| Rarefaction (or Expansion) Wave and Release Wave of E.M. Pugh | D500 |

| Section 8. Detonation (and Explosion), Pressures of and Their Measurements (Cont'd) | Page |
|--|-------------|
| Rayleigh (or Mikhel'son) Line and Transformation in Detonation | D502 |
| Reaction Front in Detonation | D503 |
| Reaction Mechanism in Detonation | D503 |
| Reaction Rate in Detonation | D504 |
| Reaction Zone in Detonation | D505 |
| Reformation of Detonation | D506 |
| Relaxation in Detonation | D507 |
| Resistance to Detonation (and Explosion) | D508 |
| Retonation Caused by the Reflection of Divergent Waves | D510 |
| Schweikert Theory of Detonation | D511 |
| Sensitivity of Explosives to Detonation | D511 |
| Shock, Shock Effect, Shock Front, Shock Impulse, Shock Pressure, Shock Wave and Shock Zone | D515 |
| Shock Compressibility in Detonation | D517 |
| Shock Hugoniot in Detonation | D517 |
| Shock Impedance and Acoustic Impedance | D518 |
| Shock- or Impact- Loading of Metals | D518 |
| Shock Pressure in Detonation and Its Measurements | D519 |
| Shock Propagation in Detonation | D519 |
| Shock Regime Thermoelectric Effect in Detonation | D520 |
| Shock Sensitivity in Detonation | D520 |
| Shock Transition to Detonation | D520 |
| Shock Transmission from Explosive to Metal Plate | D521 |
| Shock Tube Technique Studies in Detonation | D522 |
| Shock Velocity in Air and Other Substances | D529 |
| Shock Wave in Detonation (and Explosion) | D530 |
| Shock Wave Principal of Similarity, Its Application and Scaling Effects in Detonation | D541 |
| Shock Wave (or Stress Wave) Fracturing of Metal; Fracturing of Rock | D542 |
| Slurry Explosives, Detonation in | D547 |
| Sound Speed Frozen in Detonation | D547 |
| Space, Detonation (and Explosion) in | D548 |
| Spalling and Scabbing of Solids by Shocks | D548 |
| Spectra and Spectrographic Measurements in Detonation | D548 |
| Spherical Detonation | D549 |
| Spherical Taylor Wave for the Gaseous Products of Solid Explosives | D554 |
| Spike Pressure and Spike Theory | D557 |
| Spontaneous Detonation (and Explosion) | D561 |
| Stability and Instability of Detonation | D569 |
| Stability of Explosives | D572 |
| State Properties of Explosives | D574 |
| Steady and Nonsteady State In Detonation | D575 |
| Steady and Nonsteady State of Penetration of Target by Lined-Cavity Jets | D576 |
| Strain Waves in Rocks | D576 |
| Strong and Weak Detonation | D576 |
| Supercompressed Detonation Developed in Constricted Tubes | D578 |

| Section 8. Detonation (and Explosion), Pressures of and Their Measurements (Cont'd) | Page |
|--|-------------|
| Supervelocity (or Hypervelocity) Detonation | D578 |
| Surface-Erosion Model of Eyring et al as Applied in Detonation | D581 |
| TDBP Wave | D582 |
| Section 9A. Detonation (and Explosion) Temperature and Its Determination | D583 |
| Section 9B. Detonation (and Explosion), Temperature Developed on | D589 |
| Section 10. Detonation (and Explosion) Theories | D601 |
| History of Detonation Theories Leading to Development of Hydrodynamic and Hydrothermodynamic Theories | D602 |
| Hydrodynamic and Hydrothermodynamic Theories of Detonation | D610 |
| Thermal Theories and Thermochemistry of Detonation | D619 |
| Threshold Ignition Pressure in Detonation | D622 |
| Threshold Velocities V_c (Theoretical) for Impact Explosions of Massive Targets in Detonation | D623 |
| Transfer Detonation | D624 |
| Transients and Unstable Detonation Processes | D624 |
| Transition from Shock to Detonation | D625 |
| Transition of Detonation | D627 |
| Underwater Detonation (and Explosion) | D628 |
| Section 11. Detonation (Explosion and Deflagration) Velocity | D624 |
| Calculation of Detonation Velocity | D630 |
| Experimental Determination of Detonation Velocity | D633 |
| Anomalous High Detonation Velocity | D640 |
| Detonation Velocity – Charge Diameter Relationship | D641 |
| Detonation Velocity – Charge Density Relationship | D643 |
| Detonation Velocity – Charge Diameter and Density Relationships | D646 |
| Detonation Velocity and Chemical Composition and Detonation Velocity as a Function of Oxygen Balance and Heat of Formation | D656 |
| Detonation Velocity – Confinement and Obturation Relationship | D657 |
| Detonation Velocity – Critical and Limiting Diameter Relationships | D660 |
| Detonation Velocity by Direct Visualization of the Explosive Flow | D660 |
| Effect of Replacement of Air in Explosive Charges by Non-explosive Liquids | D663 |
| Detonation and Explosion Velocity in Gases | D663 |
| Influence of Ageing of Gelatin Explosives | D666 |
| Influence of Inert Components and Inert Additives | D667 |
| Influence of Magnetic, Electro Magnetic and Electrical Fields as well as of Electrons | D668 |
| Influence of Method of Initiation | D671 |
| Detonation Velocity by Metallic Transmission of Sulfur | D672 |
| Detonation Velocity – Particle Size Distribution Relationship | D672 |
| Detonation Velocity – Pressure Over Explosive Relationship | D673 |
| Detonation Velocity – Temperature (Initial) of Charge Relationship | D674 |
| Detonation, Water & Plexiglas Induced Shock Wave Velocity in | D676 |

| | Page |
|--|-------------|
| Section 12. Detonation (and Explosion) Waves | D676 |
| Course of Reactions in the Detonation Waves of Explosive Mixtures | D682 |
| Cissoidal Detonation Wave | D683 |
| Elastic Detonation Wave | D684 |
| Detonation Wave Front | D684 |
| Laminar Detonation Wave | D685 |
| Oblique Detonation Waves | D685 |
| One-Dimensional Detonation and Reaction-Waves | D686 |
| Overcompressed and Undercompressed Detonation Waves | D686 |
| Overdriven- or Supported Overdetonation Wave | D687 |
| Parameters (Characteristics) of Detonation Waves | D689 |
| Plane Detonation Wave | D689 |
| Plastic Detonation Wave | D689 |
| Predetonation Period in Detonation Wave | D690 |
| Progress of Detonation Wave | D690 |
| Propagation of Detonation Wave | D691 |
| Radius of Curvature of Its Front versus Velocity | D692 |
| Shape and Density Properties | D693 |
| Spherical Detonation Wave | D699 |
| Stationary-, Standing-, or Stabilized Detonation Waves | D700 |
| Steady Flow in Detonation Wave | D700 |
| Steady- (Steady State) and Nonsteady (Unsteady) Detonation Wave | D703 |
| Steady-State, One-Dimensional Reaction Waves with Finite Reaction Rate | D703 |
| Steady-State, One-Dimensional Reaction Waves with Instantaneous Reaction | D704 |
| Steady-State, Plane, One-Dimensional Detonation Wave | D708 |
| Steady-State, Three-Dimensional, Axially Symmetric with Finite Reaction Rate | D710 |
| Structure of Detonation Wave | D714 |
| Structure Measurements in Condensed Explosives | D715 |
| Study by a Missile Technique | D716 |
| Study by Spectrophotometric Analysis | D716 |
| Theories of Detonation Wave | D716 |
| Three-Dimensional Detonation Wave | D716 |
| Transient, One-Dimensional Wave | D716 |
| Transients in Propagation of Detonation Waves | D718 |
| Transient, Three-Dimensional Detonation Waves | D723 |
| Two-Dimensional Detonation Wave | D724 |
| | |
| Work Capacity in Detonation (and Explosion) | D730 |
| | |
| Detonative (and Explosive) Combustion or Explosive Deflagration | D731 |
| | |
| Detonative Ignition in Gases | D732 |

DETONATORS, IGNITERS, PRIMERS, AND OTHER INITIATING DEVICES
USED FOR NONMILITARY AND MILITARY PURPOSES

| | Page |
|--|-------------|
| Section 1. Detonators, Igniters and Primers Used for Nonmilitary Purposes | D733 |
| Part A. Nonmilitary Igniters | D733 |
| Part B. Nonmilitary Primers | D734 |
| Part C. Nonmilitary Detonators | D737 |
| Section 2. Detonators, Igniters, Primers and Other Initiating Devices Used for Military Purposes | D742 |
| Part A. Glossary of Ordnance and Other Terms Used in This Description of Ordnance Items | D742 |
| Part B. Nomenclature Used by US Armed Forces for Ordnance Items | D753 |
| Part C. History of Development of Military Detonators, Igniters, Primers and of Other Initiating Devices | D753 |
| Section 3. Detonators, Igniters and Primers Used for Initiating Low Explosives (Including Propellants) in Military Ammunition (Except in Fuzes) | D757 |
| Part A. Introduction | D757 |
| Part B. a) Definition of Ignition | D757 |
| b) Prime Ignition | D758 |
| c) Ignition Train Used in Pyrotechnics | D759 |
| d) Primary Initiation, First Fires, Igniters and Starters Used in Pyrotechnics | D760 |
| Part C. Military Igniters, Lighters and Firing Devices | D768 |
| a) Igniters for Fuses Used in Ordnance Items | D768 |
| b) Firing Devices | D769 |
| c) Ram-Jet Engine Igniter | D773 |
| d) Igniter Compositions for Tracers (ICT) | D774 |
| e) Igniter Compositions for Pyrotechnic Items | D774 |
| Part D. Military Primers | D774 |
| a) Definition of Term Primer | D774 |
| b) Small Arms Primers or Simple Primers | D775 |
| c ₁) Artillery Propellant Primers or Primer-Igniter | D775 |
| c ₂) Description of Various Types of Artillery Ammunition Showing the Location and Function of Primer-Igniters and of Projectiles | D777 |
| c ₃) Detailed Description of Artillery Primer-Igniters and of Some Primers Used in Cartridge Ammunition | D792 |
| c ₄) Primers for Igniting Propellants in Cartridge Bags Used in Separate-Loading Ammunition | D795 |
| d) Primers Used in Demolition Charges and in Land Mines | D797 |
| e) Primers and Igniters for Initiating Mortar Propellants and Description of Some Mortar Projectiles | D797 |
| Part E. Military Detonators | D803 |
| a) Detonators Used for Initiating Demolition Charges and Land Mines | D803 |

| | Page |
|---|-------------|
| Part E. Military Detonators (Cont'd) | |
| b) Military Blasting Caps | D806 |
| c) Exploding Bridge-Wire (EBW) Detonators | D807 |
| Section 4. Artillery and Some Other Projectiles Including their Initiating Components | D810 |
| Part A. Introduction | D810 |
| Part B. Description of Various Projectiles | D810 |
| a) Projectiles Used in Cannons and Howitzers | D810 |
| b) Projectiles Used in Recoilless Rifles | D829 |
| c) Projectiles Used in Mortars | D829 |
| d) Grenades, Hand and Rifle | D829 |
| e) Guided Missiles and Rockets | D836 |
| Part C. Definition of Terms Used for Initiating Components of Artillery Projectiles | D836 |
| a) Definition of Fuze Detonator | D836 |
| b) High-Explosive Train or Bursting Charge Explosive Train | D837 |
| Part D. Description of Instantaneous Fuze Detonators | D841 |
| a) Instantaneous Flash Fuze Detonators | D841 |
| b) Instantaneous Stab Fuze Detonators | D844 |
| c) Instantaneous Electric Fuze Detonators | D846 |
| Part E. Description of Instantaneous Fuze Primers | D850 |
| a) Instantaneous Stab Fuze Primers | D850 |
| b) Instantaneous Percussion Fuze Primers | D852 |
| c) Instantaneous Electric Fuze Primers | D854 |
| Part F. Delays, Relays, Leads and Their Uses in Fuze Detonators, Fuze Primers and Some Pyrotechnic Items | D856 |
| a) Definition of Terms | D856 |
| b) Black Powder Delay Elements | D857 |
| c) Gasless Delay Elements and Detonators Employing Them | D863 |
| d) Gasless Delay Fuze Primers | D868 |
| e) Relays and Relay Detonators | D869 |
| f) Leads (Used in Explosive Trains) | D869 |
| g) Delay Trains Used in Pyrotechnics | D872 |
| Part G. Boosters | D876 |
| Section 5. Fuzes (Introduction) | D879 |
| Part A. List of Fuzes | D879 |
| Part B. Fuzes, Igniting | D885 |
| Part C. Artillery Fuzes | D885 |
| a) Definitions | D885 |
| b) Point Detonating (PD) Artillery Fuzes, Including Time (T), Superquick (SQ) and Time Superquick (TSQ) Fuzes | D887 |
| c) Mechanical Time (MT) and Mechanical Time -Superquick (MTSQ) Artillery Fuzes | D906 |

| | Page |
|---|-------------|
| Part C. Auxiliary Fuzes (Cont'd) | |
| d) Base-Detonating (BD) Artillery Fuzes | D913 |
| e) Proximity or VT (Variable Time) Artillery Fuzes | D918 |
| f) Recoilless Rifle Projectile Fuzes | D921 |
| g) Mortar Projectile Fuzes | D922 |
| h) Foreign Artillery Fuzes of WWII | D923 |
| Part D. Fuzes for Use in Items Other Than Artillery Ammunition or Aircraft Bombs | D925 |
| a) Fuzes for Demolition Items | D925 |
| b) Fuzes for Hand- and Rifle Grenades | D927 |
| c) Fuzes for Land Mines | D928 |
| Section 6. Bombs and Bomb Components | D933 |
| Part A. Bombs | D933 |
| a) SAP (Semi-Armor-Piercing) Bombs | D933 |
| b) Frag (Fragmentation) Bombs | D933 |
| c) GP (General Purpose) Bombs | D935 |
| d) Low-Drag GP Bombs | D938 |
| e) Inc (Incendiary) Bombs | D941 |
| f) Fire Bombs | D944 |
| g) Smoke Bombs | D948 |
| h) Gas Bombs (Nonpersistent and Persistent) | D949 |
| i) Aircraft Depth Bombs (ADB) | D950 |
| j) Leaflet Bombs | D951 |
| k) Pyrotechnic Bombs (Photoflash) | D951 |
| k) Pyrotechnic Bombs (Aircraft Flares) | D953 |
| k) Pyrotechnic Bombs (Aircraft Signals) | D958 |
| l) Practice Bombs | D959 |
| Part B. Bomb Clusters and Cluster Adapters (Definition) | D959 |
| a) Quick-Opening (Frame) Fragmentation Bomb Clusters and Adapters | D961 |
| b) Aimable Fragmentation Bomb Clusters and Adapters | D961 |
| c) Incendiary Bomb Clusters | D962 |
| d) Gas Bomb Clusters and Adapters | D964 |
| Part C. Bomb Fuzes (Introduction) | D967 |
| a) Bomb Nose Fuzes | D967 |
| b) Bomb Tail Fuzes | D979 |
| c) Bomb MT (Mechanical Time) Fuzes | D990 |
| d) Bomb Proximity or VT (Variable Time) Fuzes | D995 |
| e) Hydrostatic Bomb Fuzes | D998 |
| f) Nonstandardized Bomb Fuzes | D1000 |
| g) Pyrotechnic Bomb Fuzes | D1005 |
| h) Inert Bomb Fuzes | D1008 |
| i) Foreign Bomb Fuzes Used During WWII | D1008 |
| Part D. Bomb Explosive Train Components | D1010 |
| a) Bomb Adapter-Boosters | D1010 |
| b) Bomb Auxiliary Boosters | D1012 |
| c) Bomb Primer-Detonators | D1013 |

| | Page |
|--|-------------|
| Part D. Bomb Explosive Train Components (Cont'd) | |
| d) Bomb Delay Elements | D1014 |
| e) Bomb Bursters | D1014 |
| f) Bomb Igniters | D1016 |
| Part E. Bomb Signal and Spotting Components | D1017 |
| a) Bomb Signal Cartridges | D1017 |
| b) Bomb Spotting Charges | D1019 |
| c) Bomb Spotting Charge Igniters | D1019 |
| Part F. Bomb Nonexplosive Components (Other than Clusters) | D1019 |
| a) Bomb Arming-Wire Assemblies | D1019 |
| b) Bomb Arming-Vane Assemblies | D1020 |
| c) Bomb Arming-Delay Mechanism | D1021 |
| d) Bomb Flight Stabilizers | D1021 |
| e) Drag Plates and Spoiler Rings | D1021 |
| f) Bomb Initiators | D1023 |
| Section 7. References | D1023 |
| Part A. (Books, Pamphlets and Technical Manuals on Detonators, Primers, Fuses, Fuzes and Igniters) | D1023 |
| Part B. (Patents, Technical Reports and Articles in Journals on Detonators, Primers, Fuses, Fuzes and Igniters) | D1038 |
| List of Picatinny Arsenal Technical Reports on Detonators, Primers and Igniters | D1055 |
| List of Picatinny Arsenal Technical Reports on Fuzes | D1057 |
| List of Picatinny Arsenal Memorandum Reports on Fuzes | D1058 |
| Section 8. Analytical Procedures for Explosive Compositions Used in Detonators, Primers, Igniters and Fuzes | D1060 |
| Primer Mix US Army Standard | D1060 |
| Primer Mix New No 4 | D1060 |
| Primer Mix V | D1061 |
| Primer, Percussion, M39A1 | D1061 |
| Primer Mix No 70 | D1062 |
| Primer Mix PA-100 | D1063 |
| Primer Mix NOL No 130 | D1063 |
| Primer Mix for M3 Ignition Cartridge | D1063 |
| Primer Mix in the M29A1 Percussion Primer | D1064 |
| Priming Composition (Lead Starter Type) | D1065 |
| Primer Mix | D1066 |
| Igniter, Primer, Electric, M74 | D1066 |
| Igniter Composition Type 1 of Delay Charge Composition F33B | D1067 |
| Igniter Composition Type II of Delay Charge Compositions Z-2A or Z-2B | D1068 |
| Delay Composition for Delay Elements T6E4 and T5E3 | D1069 |
| Igniter Composition for Blasting Fuse, Friction Type, M3A1 | D1070 |
| Friction Composition for Blasting Fuse, Friction Type, M3A1 | D1071 |
| Igniter Composition for M31 Series Detonators | D1071 |
| Igniter K29 | D1071 |
| Tracer R-45 | D1074 |

| | Page |
|--|-------|
| Section 9. Physical Tests for Determining Explosive and Other Properties of Detonators, Primers, Igniters and Fuzes | D1078 |
| Sensitivity (Sensitiveness) Measurements | D1078 |
| Output Tests | D1084 |
| Miscellaneous Safety Tests for Detonators and Primers | D1088 |
| Physical Tests Required by Various US Military Specifications for Detonators, Primers, Igniters and Delays | D1088 |
| Physical Testing of Fuzes | D1092 |

TABLES:

DETONATION, EXPLOSION AND RELATED SUBJECTS

| | |
|--|------|
| Chapman-Jouguet Detonation Parameters | D232 |
| Memory Effect Properties of Explosives Studied | D368 |
| Heats of Combustion, Explosion and Formation for Some Explosives of Military Interest | D380 |
| Properties of Shock Waves | D532 |
| Thermodynamic Data for Air Shock | D536 |
| Experimental Verification of Geometrical Symmetry for Shock Waves from Spherical Charges of 50/50 Pentolite | D541 |
| Properties of Hino's Explosives | D545 |
| Shape of Shock Wave for Various Rocks and Explosives and Blastability of Various Rocks | D546 |
| Comparison of Detonation Velocity Calculated by Brinkely-Wilson Mechanism with Total Energy Determined by Computer | D555 |
| Temperature to Ignition in 5 Seconds | D585 |
| Calculated Temperatures of Explosion | D591 |
| Specific Rate Constants for Assumed First-Order Isothermal Decomposition | D619 |
| Underwater Performance Data for Various Explosives | D628 |
| Detonation Velocities of Some Military Explosives at Different Densities | D634 |
| Detonation Velocities of Some Military Explosives after Storage at Various Temperatures | D635 |
| Comparison of Detonation Velocities with Other Properties of Explosives | D636 |
| Critical Diameters of Some Powdery Explosives | D653 |
| Critical Diameters of Some Liquid Explosives | D653 |

| TABLES: | Page |
|---|-------------|
| DETONATION, EXPLOSION AND RELATED SUBJECTS (Cont'd) | |
| Mean Results for Reflected Waves in Overdriven Composition B | D689 |
| Parameters of Detonation Waves in TNT | D689 |
| DETONATORS, IGNITERS, PRIMERS AND OTHER INITIATING DEVICES | |
| Safety Matches Suitable for Military Purposes | D760 |
| SAW Match Tip and Base Compositions | D760 |
| Safety Match Strikers | D761 |
| Waterproof Coating of SAW Matches | D761 |
| Black Powders Used in Pyrotechnics | D763 |
| Starter Mixtures | D764 |
| Ignition Mixtures | D766 |
| First Fire Mixtures | D767 |
| First Fire, Starter and Igniter Compositions | D767 |
| Explosive Charges Used in Foreign Flash Detonators | D843 |
| Gasless Delay Compositions | D867 |
| Ignition Powders for Gasless Delay Elements | D867 |
| Pyrotechnic Delays | D873 |
| Burning Times and Burning Rates of Fuse Trains | D876 |
| Pyrotechnic Devices Found to be Sterilizable | D1051 |
| Rim Fire Compositions of Olin Mathieson Chem Corp | D1053 |

LIST OF FIGURES AND ILLUSTRATIONS

| Detonation, Explosion and Related Subjects | Page |
|--|-------------|
| Schematic View of Experimental Arrangement for Axial Initiation of Explosives | D141 |
| Aspect of the Detonation Zone in Explosives and the Shock Wave Generated in Surrounding Medium | D142 |
| Shooting Test | D146 |
| Barrier Test | D146 |
| Relation Between Projectile Velocity and Barrier Lengths | D147 |
| End Velocity at Different Barrier Length | D147 |
| Relation Between Critical Projectile and Barrier Velocity | D147 |
| Cross-Sectional Diagram of a Blast Contour to Air | D148 |
| Blast-Contour Diagram of a Wave Emerging from TNT | D148 |
| Apparatus for Determining Concentration Limits for Combustion of Fuel Gases in Air (or Oxygen) | D154 |
| Experimental Setup of Shchelkin & Ditsent for Determining Combustion Rate of Gases | D159 |
| Propagation of Flame & Reaction Zone in Rough Pipes | D160 |
| Four Curves and CJ Point Determined by RUBY Computer Program | D181 |
| Direct Contact Detonation Sensitivity Test System | D187 |
| Reflexion of a Gaseous Detonation Wave by an Adjoining Ideal Gas | D188 |
| PETN at $1.0\text{g}/\text{cm}^3$ Primed by Two Explosives | D189 |
| Detonability Limits in the Charge Diameter-Porosity Plane (TNT & Ammonium Perchlorate) | D190 |
| Pattern of Detonation Velocity vs Porosity Curves at Various Charge Diameters (HBX-1 & Ammonium Perchlorate) | D191 |
| Shift of Detonability Limits Caused by Grinding the Material (TNT & Dynamon) | D192 |
| Effect of Density on Shock Sensitivity of Various Explosives | D193 |
| Transition of Detonation from a Narrow Tube to a Wider Tube | D197 |
| Cartridge for Determination of Critical Length | D199 |
| Development of Explosion in a Charge of TNT | D200 |
| Critical Length vs Length of Detonator | D200 |
| Critical Length vs Diameter of Detonator | D201 |
| Critical Length vs Relationship of Diameter of Detonator to Diameter of Charge | D201 |

| Detonation, Explosion and Related Subjects (Cont'd) | Page |
|--|-------------|
| Characteristic Pattern of Isotherms | D202 |
| Detonation of High Explosive | D220 |
| Build-Down and Facing of Detonation in Ballistite | D224 |
| Decay of Shock Waves | D225 |
| Steady Plane Detonation in a Solid Explosive | D230 |
| Flow Behind a Chapman-Jouguet Detonation | D236 |
| Pressure in Rarefaction Wave Behind CJ Point | D236 |
| Comparison of Curved-Front Theory with Nozzle Theory | D243 |
| End-On Photograph of the Detonation of Nitroglycerin | D243 |
| Comparison of Performance of Cu & Al Pressure-Type Resistance Element Probes | D247 |
| Charge Configuration Used to Compare Pressure Probe System with the Ionization Probe System | D248 |
| Typical Test Vessel Configuration Used for Initiation and Growth Studies of Liquid Explosives | D249 |
| Isothermal in the (p,V) Diagram | D269 |
| Arrangement for Delivery of Plane Shock Wave and for Measuring Shock-Wave Velocities | D279 |
| Arrangement for Initiating and Measuring Weak Shock Waves | D281 |
| General Setup for Shock-Pass Heat-Filter (SPHF) Initiation of Explosives | D316 |
| Large Scale Gap Test (LSGT) Assembly | D319 |
| Experimental Assembly for the Measurement of the Shock Attenuation in Lucite and Water | D319 |
| The Naval Ordnance Laboratory Gap Test for Solids | D321 |
| Drop Charge Used in Skid Test at LASL | D323 |
| Target Used in Skid Test at LASL | D323 |
| LSGT Pressure vs Gap Calibration Curve | D324 |
| NOL Modified Gap-Test Arrangement | D327 |
| Small Scale Gap Test Assembly Used by M.C. Chick | D328 |
| High Pressure Vessel with Gap Test Assembly | D328 |
| Detonation Build-Up Measurement Assembly | D329 |

| Detonation, Explosion and Related Subjects (Cont'd) | Page |
|---|-------------|
| Build-Up to Detonation in Coarse HMX Compacts | D329 |
| Small Scale Gap Test Assembly Used by J. Eadie | D329 |
| Direct Contact Detonation Sensitivity Test System | D330 |
| Shooting Test | D331 |
| Barrier Test | D331 |
| Bomb Disposal Gap Test | D332 |
| Perpendicular Gap Test Arrangement | D332 |
| Cylindrical Gap Test Arrangement | D333 |
| Test Arrangement Showing Method of Initiating Driver Explosive | D333 |
| Critical Impact Velocity as a Function of Explosive Length | D333 |
| Mod I Susan Projectile | D334 |
| Mod I Susan Projectile Early Deformation | D334 |
| Muzzle-Loaded Projectile for Type 1-Type 2 Tests | D335 |
| The Modified Gap Test | D336 |
| The Underwater System | D336 |
| Diagram of the Principle for Analysis of the Structure of a Shock Wave | D337 |
| Schematic Diagram of the Instrumentation | D338 |
| Schematic Diagram of the Experimental Setup | D338 |
| Schematic Diagram of a Transducer | D340 |
| Test Instrumentation | D341 |
| Schematic Diagram of PHERMEX | D342 |
| Experimental Geometry | D343 |
| The Complete SSGT Setup | D344 |
| Fanno Line and Rayleigh Line | D348 |
| Cross-Sectional Diagram of a Blast Contour in Air | D350 |
| Rayleigh-Mikhel'son Line | D354 |
| Apparatus for Determination of Detonation (or Explosion) Limits in Gases | D361 |
| The Phenomenalistic Steady-State Detonation Head in an Unconfined Cylindrical Charge | D364 |

| Detonation, Explosion and Related Subjects (Cont'd) | Page |
|---|-------------|
| Impact Sensitivity of High Explosives Using PA Apparatus | D392 |
| Initiation of Detonation in a High-Performance, Double-Base (HPDB) Type Propellant | D405 |
| Propagation of Detonation in an HPDB Type Propellant of Diminishing Diameter | D405 |
| Propagation of Detonation in an HPDB Type Propellant of Critical Diameter | D406 |
| Detonation of an HPDB Propellant in a Self Sealing Pressure Vessel Clamping Device with Pressure Vessel Inserted | D407 |
| Propagation of Detonation in a Conical Charge of Granular TNT | D408 |
| Development of Detonation Head | D419 |
| Radius-Time Diagram of the Formation of Shock Waves by the Detonation of a Spherical Charge | D420 |
| Typical High-Speed Camera Photograph | D425 |
| Schematic Diagram of Optical System | D427 |
| Luminosity Curve for PETN | D427 |
| Luminosity Curve for Tetryl | D427 |
| Luminosity Curve for TNT | D428 |
| Luminosity Wave Form from a Stepped Rod of Tetryl | D430 |
| Glass Wafer Passing Thru a Tetryl Charge | D432 |
| Glass Wafer Passing to a Tetryl Charge | D432 |
| Mach Reflection of Shock Wave | D435 |
| Ruby Laser | D437 |
| Shaped Charge and Target | D447 |
| Shaped Charge and Target | D447 |
| Comparison of Action of Charges | D447 |
| Various Stages of Detonation Process in Lined-Cavity Charge | D448 |
| Special Forms of Shaped Charges | D449 |
| Penetration of Steel by Lined Shaped Charge | D450 |
| Lined Cavity Charge | D450 |
| Family of Hugoniot Curves with Rayleigh-Mikhel'son Lines for a C-J Detonation and for a Strong and Weak Detonation | D454 |

| Detonation, Explosion and Related Subjects (Cont'd) | Page |
|--|-------------|
| A Rankine-Hugoniot Diagram Showing the Shock Solution of the Differential Equation | D455 |
| A Cross Plot of the Rankine-Hugoniot Diagram | D456 |
| A Schematic Illustration of the Three Possible Types of Solutions of the Detonation Equations | D456 |
| Von Neumann Pathological Weak Detonation | D458 |
| Jones Nozzle in Detonation | D458 |
| Alternate Frames Showing SPHF Initiation of Composition B | D459 |
| Experimental Arrangement for Oblique Impact Initiation of Explosives by a Metal Plate | D462 |
| One-Dimensional Precursor Shock Mechanism of Transition from Deflagration to Detonation in Solids | D481 |
| Evidence of Conduction Effects that Occur During Detonation, | D487 |
| Experimental Arrangement for Determination of Pressure of Detonation | D487 |
| Relationship Between Density and Temperature of Detonation | D493 |
| Progress of Detonation Through a Column of Explosive | D496 |
| Development of Detonation Head in an Ideal Detonation | D501 |
| Flow in a Steady, Normal Shock | D517 |
| Shock Transmission from Explosive to Metal Plate | D521 |
| Shock Tube Representation | D522 |
| Time-Distance Plot Showing the Location of the Rarefaction Wave, Piston, and Shock Wave | D523 |
| Shock Tube and Charging Equipment | D525 |
| Diaphragm Assembly | D525 |
| Formation of a Shock Wave | D530 |
| Decay of Shock Waves | D531 |
| Detachment Angles of Shock Waves | D533 |
| Shock Velocity V^* versus S and Average Velocity V_1^* versus S for Propagation by Influence in Air for a Straight Dynamite and 65/35 Tetrytol | D535 |
| Space-Time Diagram of the Spherical Taylor Wave | D556 |
| Spin Detonation | D557 |

| Detonation, Explosion and Related Subjects (Cont'd) | Page |
|--|-------------|
| Two Methods of Graphical Presentation of Chemical Decomposition of Explosives | D572 |
| Apparatus of Lambrey for Testing Chemical Stability of Explosives | D573 |
| Flow in a Strong Detonation | D576 |
| Two Possible Weak Detonation Solutions for Given P and u_0, p_0 | D577 |
| Flow in a Chapman-Jouguet Detonation | D578 |
| Explosion Temperature Test Apparatus | D583 |
| Flame Front in a Constant-Area Duct | D604 |
| Hugoniot Curve $H^{(1)} = J^{(1)}$ of Reaction Products with Sections Corresponding to Strong, Chapman-Jouguet, and Weak Detonations and Deflagrations | D606 |
| Hugoniot Curve $H^{(1)} = J^{(1)}$, Rayleigh-Mikhel'son Lines and Adiabats | D607 |
| Correlation of Explosives by $\alpha(v)$ Equation of State | D613 |
| Threshold Ignition Pressure p_1^0 versus H_2/O_2 Ratio for Ignition of Propellants | D623 |
| Wedge-Test Arrangement | D626 |
| Charge Diameter vs Detonation Velocity of RDX of Density ca 1.0g/cc | D642 |
| Velocity (D) versus Density (ρ_1) Curves for HBX and Tritonal | D647 |
| Velocity (D) versus Diameter (d) or D(d) Curves for HBX and Tritonal | D647 |
| Velocity-Diameter Curves for Some Military Explosives | D648 |
| Velocity-Diameter Curves for Some Commercial Explosives | D648 |
| Relationship: Detonation Velocity (D) vs Relative Density A | D649 |
| Relationship: Detonation Velocity vs Density of Charge | D649 |
| Relationship of Critical Diameter vs Density of Pressed TNT | D650 |
| Relationship of Detonation Velocity and Diameter of Charge for 50/50 Amatol of Density 1.53g/cc | D650 |
| Influence of Diameter and Particle Size of a Charge on its Detonation Velocity | D651 |
| Detonation Velocity vs Density of Cheddite | D651 |
| Typical Velocity-Density Curves for AN-Combustible Mixtures in Small Diameter | D652 |
| Critical Diameter vs Density of Charge | D652 |

| Detonation, Explosion and Related Subjects (Cont'd) | Page |
|--|-------------|
| Critical Diameter vs Density of 50/50 Amatol | D652 |
| Detonation Velocity vs Density of Charge for 50/50 Amatol | D652 |
| Experimental Arrangement for Direct Visualization of Explosive Flow | D661 |
| (x,t) Diagram – Cylindrical Charge 30-mm Diameter | D662 |
| % C ₃ H ₈ in Mixture with Oxygen | D664 |
| Density vs Detonation Velocity of 2H ₂ +O ₂ | D665 |
| Influence of Aging on High and Low Velocity of a Gelatin | D667 |
| Experimental Arrangement of Ionization Probing Diagram | D669 |
| Electronic Circuit Diagram for Ionization Probing | D669 |
| Pressure Profile of a Detonation Wave Occurring in a Charge of Finite Extent | D677 |
| One-Dimensional Steady-State Detonation in a Solid Explosive | D678 |
| Chapman-Jouguet Velocity of Detonation Waves | D680 |
| Derivation of the Chapman-Jouguet Detonation Velocity | D680 |
| Experimental Arrangement for Obtaining Oblique Detonation Waves | D685 |
| Photographic Arrangement for Oblique Detonation Waves | D686 |
| Development of Detonation Head | D694 |
| The Phenomenalistic Steady-State Detonation Head in an Unconfined Cylindrical Charge | D695 |
| Representative Plots of Reduced Data Showing Sphericity of Wave Front | D696 |
| Variation of Wave Shape with Charge Length in Ideal Detonation | D698 |
| Variation of Wave Shape with Charge Length in Nonideal Detonation | D698 |
| Straight Characteristics and Particle Paths in a Simple Wave | D702 |
| Hugoniot Curve $H^{(1)} = J^{(1)}$ of Reaction Products | D705 |
| Hugoniot Curve $H^{(1)} = J^{(1)}$, Rayleigh-Mikhel'son Lines and Adiabats | D706 |
| Hugoniot Curve for Final Conditions p_2, τ_2 (Point 6) | D707 |
| Sectional Diagram of the Steady Detonation Wave from the Standpoint of an Observer Accompanying the Wave | D708 |
| Schematic Diagram of Cylindrically Symmetric Flow in a Detonation Wave, with Coordinate System at Rest in the Detonation Front | D711 |
| Schematic Diagram of a Spherically Symmetric Flow in the Steady Zone of a Detonation Wave | D712 |

| Detonation, Explosion and Related Subjects (Cont'd) | Page |
|---|-------------|
| Prandtl-Meyer Flow within a Steady Detonation Zone | D713 |
| Flow in a Steady Detonation Zone with Turbulent Boundary Layer, with Coordinate System at Rest in the Shock Front | D713 |
| Typical Dual-Velocity Traces for Cap Initiated, Loose Tetryl and EDNA | D713 |
| Velocity Trace for Coarse, Low-Density TNT | D720 |
| Typical Velocity-Density Curves for An-Combustible Mixtures in Small Diameter | D721 |
| Cannon Pressure-Time Curve for Fine PETN | D722 |
| Photograph of a "Zebra" Charge, Showing Intense Luminosity in Salt Zones | D730 |
| Detonators, Igniters, Primers, and Other Initiating Devices Used for Nonmilitary and Military Purposes | |
| Dynamite Primer | D734 |
| Dynamite Electric Primer | D734 |
| Priming of Dynamite Charges Fired with Caps and Safety Fuses | D736 |
| Priming of Dynamite Charges Fired with Electric Blasting Caps | D736 |
| Indirect Priming of Permissible Explosives | D737 |
| Neoprene Plug Assembly (Electric Detonator) | D738 |
| Low-Tension Fusehead for Electric Detonator | D738 |
| Two Types of British Electric Delay Detonators | D739 |
| British Electric Delay Detonator with an Intermediate Charge | D739 |
| British Electric Short Delay Detonator | D740 |
| The Sequence of Events in Firing Detonators | D741 |
| Theory of Series Firing with Two Types of Electric Detonators | D742 |
| Activator M1 | D743 |
| Two Types of Baffles | D744 |
| Earliest Method of Initiation | D754 |
| Earlier Types of Paper Cartridges | D754 |
| Paper Cartridge of Gustavus Adolphus of Sweden | D755 |
| Time Blasting Fuse Igniter M1 (Friction Type) | D768 |
| Time Blasting Fuse Igniter M2 (Weatherproof Type) | D768 |

**Detonators, Igniters, Primers, and Other Initiating Devices
Used for Nonmilitary and Military Purposes (Cont'd)**

| | Page |
|--|-------------|
| Time Blasting Fuse Igniter M60 (Weatherproof Type) | D769 |
| Delay Type Firing Device M1 | D769 |
| Pull Type Firing Device M1 | D770 |
| Release Type Firing Device M1 | D771 |
| Pressure Type Firing Device M1A1 | D771 |
| Pull-Friction Type Firing Device M2 | D771 |
| Pull-Release Type Firing Device M3 | D772 |
| Pressure-Release Type Firing Device M5 | D773 |
| Ram-Jet Engine Igniter M114 (45-Second) | D773 |
| Igniter Composition in Armor-Piercing-Tracer Shell | D774 |
| Percussion Primers for Small Arms Ammunition | D776 |
| Small Arms Cartridge Components Using Center Fire Obturated Primer | D777 |
| 37-mm HE-T, SD Fixed Ammunition M54A1 for Automatic Guns | D778 |
| 40-mm HEI-T, SD Fixed Ammunition Mk2 & Mk11 for Automatic Guns | D778 |
| 75-mm AP-T Fixed Ammunition M338A1 for Gun Cannons | D779 |
| 75-mm APC-T Fixed Ammunition M61A1 for Gun Cannons | D780 |
| 76-mm Canister Fixed Ammunition M363 for Gun Cannons | D781 |
| 76-mm HVAP-DS-T Fixed Ammunition M331 Series for Gun Cannons | D782 |
| 90-mm APC-T Fixed Ammunition M82 for Gun Cannons | D782 |
| 90-mm HEAT Fixed Ammunition M348A1 (T108E46) for Gun Cannons | D783 |
| 90-mm HVAP-T Fixed Ammunition M332A1 for Gun Cannons | D784 |
| 105-mm APDS-T Semifixed Ammunition M392A2 for Gun Cannons | D784 |
| 105-mm HEAT-T Semifixed Ammunition M456 Series for Gun Cannons | D785 |
| 105-mm HE Semifixed Ammunition M1 for Howitzer Cannons | D785 |
| 105-mm HE, RA Semifixed Ammunition XM548 for Howitzer Cannons | D786 |
| 105-mm APERS-T (Antipersonnel-Tracer) Semifixed Ammunition XM546 for Howitzer Cannons | D787 |
| 152-mm HEAT-T-MP Fixed Ammunition XM409E3 for Gun Cannon M81 | D788 |
| 152-mm TP-T Fixed Ammunition XM411E3 for Gun Cannon M81 | D789 |
| 57-mm Canister Fixed Ammunition T25E5 for Recoilless Rifles | D790 |

| Detonators, Igniters, Primers, and Other Initiating Devices Used for Nonmilitary and Military Purposes (Cont'd) | Page |
|--|-------------|
| 75-mm HEAT-T Fixed Ammunition M309A1 for Recoilless Rifles | D790 |
| 90-mm A/P Canister Fixed Ammunition XM590 for Recoilless Rifles | D790 |
| 105-mm HEAT Fixed Ammunition for Recoilless Rifles | D791 |
| 106-mm HEAT Fixed Ammunition M344A1 for Recoilless Rifles | D792 |
| Primers for Igniting Propellants in Fixed and Semifixed Ammunition | D793 |
| Primer for Igniting Propellants in Recoilless Rifles Ammunition | D794 |
| Comparison of Electric Primer with Percussion Primer | D794 |
| Combination of Electric and Percussion Primer Mk15 Mod 2 for Separate-Loading Ammunition | D795 |
| Propelling Charge M19 for 155-mm Separate-Loading Gun Ammunition | D796 |
| Percussion Primer Mk244 for Igniting Propellant in Separate-Loading Ammunition | D796 |
| Percussion Primer M82 for Igniting Propellant in Separate-Loading Ammunition | D796 |
| Percussion Primers M2, M27 & M39A1 Used in Demolition Devices and Land Mines | D797 |
| 60-mm Mortar Cartridge Being Fired | D797 |
| Primer and Ignition Cartridge for 60-mm Mortar | D798 |
| High-Explosive Round for 60-mm Mortar | D799 |
| Primers and Ignition Cartridges for 81-mm Mortar | D800 |
| High-Explosive Round M374 for 81-mm Mortar | D800 |
| High-Explosive Round M329 for 4.2-inch Mortar M30 | D802 |
| Ignition Cartridge Primer M2 | D803 |
| Concussion Detonator M1, Delay Type | D804 |
| Friction Detonator M2, 8-second Delay | D804 |
| Friction Detonator M1, 15-second Delay | D805 |
| Percussion Detonator M1A2 (M1E1), 15-second Delay | D805 |
| Special Military Nonelectric Caps | D806 |
| Special Military Electric Cap M6 | D807 |
| Medium Energy EBW Detonator w/Wollaston Wire | D808 |
| EBW Plug (HV-1) Modified for Very High Voltage | D808 |

| Detonators, Igniters, Primers, and Other Initiating Devices Used for Nonmilitary and Military Purposes (Cont'd) | Page |
|--|-------------|
| EBW Detonator Design for High Voltage Application | D809 |
| EBW Detonator with Stepwise Increasing Bore | D809 |
| Typical HE (High Explosive) Projectile W/O Tracer | D814 |
| Typical HE-T (High-Explosive-Tracer) Projectile | D815 |
| Typical HE Projectile w/Suppl Charge | D816 |
| 175-mm HE, M437A2 Projectile with Supplementary Charge | D817 |
| 175-mm Propelling Charge M86A1 | D817 |
| 280-mm HE Projectile M124 (T122E4) w/Suppl Charge | D818 |
| 280-mm Propelling Charge M43 | D818 |
| Typical HEAT-T (High-Explosive, Antitank-Tracer) Projectile | D819 |
| Typical AP-T (Armor-Piercing-Tracer) Projectile | D820 |
| Typical APC-T (Armor-Piercing, Capped-Tracer) Projectile | D820 |
| Typical AVAP-T (Hypervelocity, Armor-Piercing-Tracer) Projectile | D821 |
| Typical Canister Projectile | D822 |
| 155-mm Illuminating Projectile M118 Series for Howitzer Cannons | D822 |
| Illuminate Canister for 155-mm Projectile M485 | D823 |
| 120-mm WP-T (White Phosphorus-Tracer) Smoke Projectile M357 (T16E4) (Burster Type) | D824 |
| Typical BE (Base-Ejection) Smoke Projectile | D825 |
| 155-mm BE (Base-Ejection) Smoke Projectile M116 | D825 |
| 155-mm CS Tactical Projectile XM631 | D826 |
| 155-mm VX Persistent Gas Projectile M121A1 | D827 |
| 75-mm Blank Cartridge w/Single Pellet (Bag) Charge | D828 |
| 75-mm Blank Cartridge w/Double Pellet (Bag) Charge | D828 |
| Fragmentation Hand Grenade Mk 2 w/Fuze M204A2 | D830 |
| Fragmentation Hand Grenade M26 w/Fuze M215 | D830 |
| Fragmentation Hand Grenade M26A2 w/Fuze M217 | D831 |
| Illuminating Hand Grenade MK 1 w/Delay Ignition Fuze | D832 |
| Smoke Hand Grenade, HC, AN-M8 w/Fuze M201A1 | D832 |
| Antitank Rifle Grenade HEAT, M31 w/Fuze M211 | D833 |

| Detonators, Igniters, Primers, and Other Initiating Devices Used for Nonmilitary and Military Purposes (Cont'd) | Page |
|--|-------------|
| Smoke Rifle Grenade, WP, M19A1 w/Fuze MID | D834 |
| Rifle Grenade Cartridges, M3 & M4 | D835 |
| Grenade Projection Adapter, M1A2 | D835 |
| Grenade Projection Adapter, M2A1 | D836 |
| Diagram of Elements of Explosive Trains | D838 |
| Explosive Trains in Fixed Round of Artillery Ammunition | D839 |
| Base Fuze MK 21 (Assembled Position) | D840 |
| Base Fuze Mk 21 (Firing Position) | D841 |
| Examples of Flash Type Fuze Detonators | D842 |
| Two General Types of Stab Fuze Detonators | D844 |
| Typical US Army Fuze Detonators | D845 |
| Navy Electric Detonator Mk 46 Mod 0 | D846 |
| Navy Electric Detonator Mk 51 Mod 0 | D847 |
| Army Electric Detonator M36 | D847 |
| Army Electric Detonator M48 | D848 |
| Army Electric Detonator T20E1 | D848 |
| Electric Delay Detonator T65 | D849 |
| Button-Type Electric Detonator T62 | D850 |
| Typical Stab Fuze Primer | D850 |
| Army and Navy Stab Fuze Primers | D851 |
| Navy Fuze Primer Mk 101 Mod 0 | D852 |
| Navy Fuze Primer Mk 105 Mod 0 | D852 |
| Army Fuze Primer M29 | D853 |
| Army Fuze Primer, New No 4 | D853 |
| Navy Electric Fuze Primer Mk 112 Mod 0 | D855 |
| Navy Electric Fuze Primer Mk 121 | D855 |
| Navy Experimental Spray Metal Electric Fuze Primer | D856 |
| Army and Navy Delay Elements and Delays | D858 |
| Navy Delay Element, Obturated Column Type with Baffle (in Firing Position) | D859 |

**Detonators, Igniters, Primers, and Other Initiating Devices
Used for Nonmilitary and Military Purposes (Cont'd)**

| | Page |
|--|-------------|
| Navy Delay Element, Obturated Column, W/O Baffle | D859 |
| Navy Delay Element, Obturated Column Type with Baffle | D860 |
| Army Delay Element, Obturated Column Type, W/O Baffle | D860 |
| Army Delay Element, Obturated Column Type, W/O Baffle | D861 |
| Army Delay Element, Obturated Column Type, with Baffle | D861 |
| Vented Time Delay Ring or Train W/O Baffle | D862 |
| Pressure Type, Vented Delay Element, with Baffle | D862 |
| Pressure Type, Vented Delay Element with Baffle | D863 |
| Obturated Gasless Delay Element for 4 to 6 Seconds Percussion Detonator | D864 |
| Flame Initiated 0.10 Second Flash Delay Detonator | D864 |
| Stab-Initiated 0.02 Second Delay Detonator | D865 |
| Electric Delay Detonator Mk 35 Mod 1 | D866 |
| Obturated Gasless Delay Element | D866 |
| Typical 4-5 Second Non-Obturated Gasless Delay Element | D867 |
| Gasless Electric Fuze Primer Mk 115 | D868 |
| Experimental Delay Primer | D868 |
| Relay Detonator | D870 |
| Location of Lead-In and Lead-Out in the Firing Train. Armed Position | D870 |
| Location of a Lead in a Firing Pin | D871 |
| Army Pre-Flanged Lead Cup | D871 |
| Army Lead Cup Inserted in Fuze Bulkhead | D871 |
| Navy Lead Cup Placed in Fuze Bulkhead and then Flanged | D871 |
| Non-Cup Type or Open-Type Lead | D872 |
| Scoring the Wall of the Lead Hole | D872 |
| Booster Assembly for BD Fuze, Mk 21 | D876 |
| Booster Assembly for BD Fuze, M60 | D877 |
| Booster Assembly for Auxiliary Detonating Fuze Mk 44 | D878 |
| Booster Assembly for Bomb Fuze, AN-M103A1 | D878 |

**Detonators, Igniters, Primers, and Other Initiating Devices
Used for Nonmilitary and Military Purposes (Cont'd)**

| | Page |
|--|-------------|
| Fuze, Igniting M74 | D885 |
| Fuze, PD, SQ Mk 27 | D887 |
| Fuze, PD, SQ-Delay M51A1 | D889 |
| Fuze, PD M52A1 | D890 |
| Fuze, PD, TSQ, M54 | D892 |
| Fuze, PD, M56 | D893 |
| Fuze, Time (Fixed), M65A1 | D894 |
| Fuze, PD, M75 (Modification of Navy's Mk 1) | D895 |
| Fuze, TSQ, M77 | D896 |
| Fuze, PDCP, M78 | D897 |
| Fuze, Time, M84 | D898 |
| Fuze, PD, M89 | D899 |
| Fuze, PI, M90A1 | D900 |
| Fuze, PD, M503A1 | D901 |
| Fuze, PD, M557 | D903 |
| Fuze, PD, XM593 (Unarmed Position) | D905 |
| Fuze, PD, XM593 (Armed Position) | D906 |
| Fuze, MT, M43A4 | D907 |
| Fuze, MTSQ, M548 | D911 |
| Fuze, MTSQ, M548 (Explosive Trains) | D912 |
| Fuze, MTSQ, M564 | D912 |
| Fuze, BD, M58 | D913 |
| Fuze, BD, M66A2 | D914 |
| Fuze, BD, M72 | D914 |
| Fuze, BD, M91A1 | D915 |
| Fuze, PIBD, M530A1 | D916 |
| Fuze, BD, M578 | D918 |
| Typical VT Artillery Fuze | D919 |
| Bullet Impact Fuze, M1A1 for Demolition Snake M3 | D926 |
| Longitudinal Section of Projected Charge M3A1 at Fuze M1A1 | D926 |
| Hand Grenade Fuze, M215 | D927 |
| Hand Grenade Fuze, M217 | D927 |

| Detonators, Igniters, Primers, and Other Initiating Devices Used for Nonmilitary and Military Purposes (Cont'd) | Page |
|--|-------------|
| Hand Grenade Fuze, M201A1 | D928 |
| Antipersonnel Mine, NM, M14 w/Integral Mine Fuze | D929 |
| Antipersonnel Mine, M2A4 w/Mine Fuze, M6A1 | D930 |
| Antipersonnel Mine, M16 w/Combination Mine Fuze, M605 | D931 |
| Antitank Mine Fuze, M603 (T17E2) | D931 |
| Heavy Antitank Mine, M6A2 w/Mine Fuze, M603 | D932 |
| Light, HE, A/T Mine M7A2 w/Mine Fuze, M603 | D932 |
| 1000-lb SAP Bomb, AN-M59A1 | D934 |
| 90-lb Frag Bomb, M82 | D935 |
| 260-lb Frag Bomb, AN-M88 | D936 |
| GP Bomb (Old Series) | D937 |
| GP Bomb (New Series) | D938 |
| Low-Drag GP Bomb | D939 |
| Low-Drag GP Snakeye I Bomb (With Fin-Assembly Closed) | D940 |
| Low-Drag GP Snakeye I Bomb (With Fin-Assembly Open) | D940 |
| 4-lb TH3 Inc Bomb, M126 | D941 |
| 10-lb PT 1 Inc Bomb, M74A1 | D942 |
| 100-lb Inc Bomb, AN-M47A4 | D943 |
| 750-lb Fire Bomb, M116A2 | D945 |
| 750-lb Fire Bomb, Mk 78 Mod 2 | D946 |
| 1000-lb Fire Bomb, Mk 79 Mod 1 | D947 |
| Fire Bomb, BLU Series (Components) | D948 |
| 100-lb PWP (or WP) Smoke Bomb, AN-M47A4 | D948 |
| 100-lb Nonpersistent Gas Bomb, M125A1 | D949 |
| 750-lb GB Nonpersistent Gas Bomb, MC-1 | D950 |
| 350-lb Depth Bomb, AN-Mk 54 Mod 1 | D951 |
| Photoflash Cartridge, M112A1 (1, 2 & 4-Second Delay) | D952 |
| Photoflash Cartridge, M123A1 (2-Second Delay) | D952 |
| Photoflash Cartridge, M123A1 (4-Second Delay) | D953 |
| 100-lb Photoflash Bomb, M122 | D954 |
| Aircraft Parachute Flare, M26A1 (AN-M26) | D955 |
| Aircraft Parachute Flare, M26A1 (Operation) | D957 |

| Detonators, Igniters, Primers, and Other Initiating Devices Used for Nonmilitary and Military Purposes (Cont'd) | Page |
|--|-------------|
| Aircraft Signal, Illumination, Double Star, Red-Red, AN-M37A1 | D959 |
| Aircraft Signal, Smoke and Illumination, AN-Mk 6 Mod 3 | D960 |
| 100-lb Frag Bomb Cluster, AN-M1A2 | D961 |
| Cluster-Adapter, AN-M1A3 | D962 |
| 100-lb Frag Bomb Cluster, M28A1 | D963 |
| 500-lb PT1 Inc Bomb Cluster, M31 | D964 |
| 750-lb PT1 Inc Bomb Cluster, M35 | D964 |
| 1000-lb GB Nonpersistent Gas Bomb Cluster, M34A1 (or M34) | D965 |
| Gas Bomb Cluster, M34A1 (Converted to Streamlined Version for External Stowage on Aircraft) | D965 |
| Cluster Adapters M25, M26 & M29 (Gas Chamber Closure Cap and Fin Assembly Removed) | D966 |
| 750-lb Cluster Adapter, M30 | D967 |
| Bomb Nose Fuze, AN-M103A1 | D968 |
| Bomb Nose Fuze, AN-Mk 219 | D970 |
| Bomb Nose Fuze, Mk 243 Mod 0 | D971 |
| Bomb Nose Fuze, M904E2 | D972 |
| Bomb Nose Fuze, M197 | D974 |
| Bomb Nose Fuze, AN-M159 | D975 |
| Bomb Nose Fuze, M157 | D977 |
| Bomb Nose Fuze, M157 (Installed in Igniter M15) | D977 |
| Bomb Nose Fuze, AN-M173A1 | D978 |
| Bomb Tail Fuze, AN-M100A1 | D980 |
| Bomb Tail Fuze, M115 | D982 |
| Bomb Tail Fuze, AN-Mk 228 | D983 |
| Bomb Tail Fuze, M123A1 | D985 |
| Bomb Tail Fuze, M123A1 (Operation) | D986 |
| Bomb Tail Fuze, M132 | D987 |
| Bomb Tail Fuze, M906 | D989 |
| Bomb Nose MT Fuze, AN-M146A1 (Unarmed) | D991 |
| Bomb Nose MT Fuze, AN-M136A1 (Armed) | D992 |
| Bomb Nose Mt Fuze, M155A1 | D994 |
| Bomb Nose (or Tail) MT Fuze, M907 | D995 |

| Detonators, Igniters, Primers, and Other Initiating Devices Used for Nonmilitary and Military Purposes (Cont'd) | Page |
|--|-------------|
| Bomb Nose Proximity (VT) Fuzes (Ring Type and Bar Type) | D996 |
| Bomb Nose Proximity (VT) Fuze, AN-M166 | D997 |
| Bomb Tail Hydrostatic Fuze, AN-Mk 230 | D999 |
| Bomb Tail Hydrostatic Fuze, AN-Mk 230 (Comparison of Boosters) | D1000 |
| Bomb Nose MT Fuze, M129 | D1001 |
| Bomb Nose MT Fuze, M130 | D1002 |
| Bomb Nose MT Fuze, M131A1 (Cross Section and Detail of Operation) | D1004 |
| Pyrotechnic Bomb Nose Fuze, AN-M146A1 | D1006 |
| Pyrotechnic Bomb Nose Fuze, AN-M136A1 (Arming Mechanism) | D1007 |
| Bomb Tail Adapter-Booster, M102A1 | D1011 |
| Bomb Tail Adapter-Booster, M115A1 | D1011 |
| Bomb Tail Adapter-Booster, M117 | D1012 |
| Bomb Adapter-Booster, M126A1 (T45E1) | D1012 |
| Bomb Adapter-Booster, T46E4 | D1012 |
| Bomb Auxiliary Booster, Mk 1 Mod 0 | D1013 |
| Bomb Auxiliary Booster, Mk 4 Mod 0 | D1013 |
| Bomb Primer-Detonator, M14 | D1013 |
| Bomb Primer-Detonator, M16 | D1014 |
| Bomb Delay Elements, M9, T5E3 & T6E4 | D1014 |
| Bomb Burster, AN-M18 | D1015 |
| Bomb Burster, CSR1 | D1015 |
| Bomb Igniter, AN-M9 | D1016 |
| Bomb Igniter, AN-M16 | D1017 |
| Bomb Igniter, AN-M23A1 | D1017 |
| Practice Bomb Signals, Mk 4 Mods 3 & 4 | D1018 |
| Practice Bomb Signal, Mk 6 Mod 0 (With Fuze) | D1018 |
| Bomb Spotting Charge, M39A1 | D1019 |
| Bomb Arming-Wire Assemblies (Various Types) | D1020 |
| Bomb Arming-Vane Assemblies (Various Types) | D1020 |
| Bomb Fin Assemblies (Box Type) | D1021 |
| Bomb Fin Assemblies (Conical Type) | D1022 |
| Fin Assemblies for Chemical Clusters | D1022 |

| Detonators, Igniters, Primers, and Other Initiating Devices Used for Nonmilitary and Military Purposes (Cont'd) | Page |
|--|-------------|
| Bomb Fin Assemblies (Retarding Type) | D1022 |
| Bomb Initiators, FMU-7/B & FMU-7A/B | D1023 |
| Ignition Cartridge M2A1 | D1029 |
| M2 Ignition Cartridge Primer | D1030 |
| Schematic Arrangement of Latest Hajeck's Ignition Device | D1042 |
| Sterilizable Igniter | D1052 |
| Assembly for Eudiometer Method | D1073 |
| Test Set Mk 136 Mod 0 for Stab Primers and Stab Detonators | D1080 |
| Test Set Mk 135 Mod 0 for Percussion Primers | D1082 |
| Test Set Mk 173 Mod 0 for Percussion Primers | D1083 |
| Detail of Lead Disk Mounting Below Detonator in Plastic Holder | D1084 |
| Stauchapparat, Without Protective Cylinder | D1085 |
| Test Set Mk 172 Mod 1, for Percussion, Stab and Electric Primers | D1086 |
| Initiator Output Test Fixture | D1088 |

**SUPPLEMENT TO ABBREVIATIONS, CODE NAMES AND SYMBOLS
GIVEN IN VOL 1, pp Abbr 1 to 65; VOL 2, p IX, AND VOL 3, pp IX to X**

| | |
|-----------|---|
| ACI, REL | Atlas Chemical Industries, Reynolds Experimental Laboratory, Tamaqua, Pa |
| AFBE | Association des Fabricants Belges d'Explosifs, Bruxelles, Belgium |
| ALEX | Aluminized Explosives |
| Alex 20 | RDX/TNT/Al/Wax 44/32.2/19.8/4.0 |
| ATWB | Symbol for US Air Force Armament Laboratory, Eglin AFB, Florida 32542 |
| ATWR | Symbol for US Air Force Directorate of Armament Development, Eglin AFB, Florida 32542 |
| AWRE | Atomic Weapons Research Establishment, Aldermaston, Berkshire, England |
| BMEWS | Ballistic Missile Early Warning System |
| BTNEN | Bis(2,2,2-trinitroethyl)-nitramine |
| CÉA | Commissariat a l'Énergie Atomique, Sevrans (93) & Paris, France |
| CÉG | Centre d'Études de Gramat, Gramat (Lot), France |
| CER | Combustion and Explosives Research, Inc, Pittsburgh, Pa |
| CFSTI | Clearinghouse for Federal, Scientific, and Technical Information, US Department of Commerce, Springfield, Va 22151 |
| CLA | Colloidal Lead Azide (See Vol 1, p A558) |
| CPIA, APL | Chemical Propulsion Information Agency, Applied Physics Laboratory, The Johns Hopkins University, Silver Spring, Md |
| CRIFE | Centre de Recherches pour l'Industrie des Produits Explosifs, Val du Bois (Steerbeek, Brabant), Belgium |
| DAD | Directorate of Armament Development (ATWR), Eglin AFB, Florida 32542 |

| | |
|---------------|--|
| DASA | Defense Atomic Support Agency, The Pentagon, Washington, DC |
| DATNB or DATB | 1,3-Diamino-2,4,6-trinitrobenzene described in Vol 5 under Diaminobenzene and Derivatives as 2,4,6-Trinitro-1,3-diaminobenzene [See also AMCP 706-177 (March 1967) p95] |
| DCLA | Dextrinated Colloidal Lead Azide (See Vol 1, p A558) |
| DDC | Defense Documentation Center, Cameron Station, Alexandria, Va 221314 |
| DDT | Deflagration to Detonation Transition |
| DEFA | Direction des Études et Fabrication d'Armement, Gramat (Lot), France |
| 'D' Explosif | 85/15 RDX/TNT [Ref: C. Fauquignon et al, 4th SympDeton (1965), p45, Fig 10]. <i>NOTE:</i> This compn is not to be confused with US Explosive 'D' which is Ammonium Picrate |
| DEW | Distant Early Warning |
| DEW Line | A line of radar stations at ca 70th parallel on the North American Continent, undertaken in cooperation with the Canadian Government |
| DFFI or IFAR | Deutsch-Frazösisch Forschungsinstitut, St Louis or Institut Franco-Allemand de Recherches de Saint Louis (Haut Rhin) France |
| DIPAM | Dipicramide; 2,4,6,2',4',6'-Hexanitro-3,3-diaminobiphenyl; or 2,4,6,2',4',6'-Hexanitro-3,3-biphenyldiamine described in Vol 5 under Diaminobiphenyl, Nitrated Derivatives |
| DLA | Dextrinated Lead Azide (See Vol 1, p A558) |
| DPEL | DuPont Eastern Laboratory, Gibbstown, NJ |
| EBC | Ensign-Bickford Company, Simsbury, Conn |
| EBW | Exploding Bridge Wire |
| EDB | Ethyldecaborane |
| EDDN | Ethylenediamine Dinitrate |
| EED | Electroexplosive Device |

| | |
|----------------------|---|
| EIE | "Exchanged Ion Explosive". A Belgian Safety Explosive consisting of NG 10 & stoichiometric mixt of AN & KN 90% [Ref: 4th ONRSympDeton (1965), p 159-L.] |
| EL-511 | DuPont Company designation for the HE Dipicrylsulfone or 2,4,6,2',4',6'-Hexanitrodiphenylsulfone, $(O_2N)_3C_6H_2SO_2C_6H_2(NO_2)_3$ |
| ERC, BM | Explosives Research Center, US Bureau of Mines, Pittsburgh, Pa |
| ESL | Engineering Sciences Laboratory, FRL, Picatinny Arsenal, Dover, NJ 07801 |
| Estane | Trademark of Goodrich Chemical Company for a thermoplastic polyurethane [Ref: CondChemDict (1961), p 450] |
| FFA | Försvarets Forskningsanstalt. See RIND (FFA) |
| FOBS | Abbr For Orbital Bombing System |
| FRL | Feltman Research Laboratories, Picatinny Arsenal, Dover, NJ |
| H-6 | American HE: RDX 45, TNT 30, Aluminum 20 & D-2 (desensitizer) 5% with 0.5% $CaCl_2$ added [See AMCP 706-177 (March 1967), p 147] |
| Hawk | US Army Surface-to-Air Missile for use against low flying planes |
| HBX-1 | American HE: RDX 40, TNT 38, Aluminum 17 & D-2 (desensitizer) 5% with 0.5% $CaCl_2$ added [See AMCP 706-177 (March 1967), p 156] |
| HBX-3 | American HE: RDX 31, TNT 29, Aluminum 35 & D-2 (desensitizer) 5% with 0.5% $CaCl_2$ added [See AMCP 706-177 (March 1967), p 159] |
| HNDPhA | Hexanitrodiphenylamine [See in Vol 5 under Diphenylamine and Derivatives and in USP 3418372 (Dec 1968)] |
| HNS or HNS tb | Hexanitrostilbene or Hexanitrodiphenylethylene |
| ICBM | Intercontinental Ballistic Missile |
| IFAR | See DFFI |

| | |
|----------------------|--|
| IITRI | Illinois Institute of Technology Research Institute, Chicago, Ill |
| IM Incendiary Oil | Isobutyl Methacrylate Incendiary Oil, Type 1 has the following compn: gasoline 88.75, Isobutyl-methacrylate, polymer AE 5.0, Calcium oxide 2.0 & Water 1.25% [Ref: TM 3-215/AFM 355-7 (Dec 1963), p 41] |
| LAMS | Los Alamos (Laboratory) Manuscript |
| LASL | Los Alamos Scientific Laboratory |
| LHP, CNRS | Laboratoire des Hautes Pressions, Centre National de la Recherche Scientifique, Bellevue (Seine et Oise), France |
| LMSC | Lockheed Missile and Space Company, Sunnyvale, Calif |
| LOD, GP | Link Ordnance Division, General Precision, Inc, Sunnyvale, Calif |
| LRL, UC | Lawrence Radiation Laboratory, University of California, Livermore, Calif |
| LX-04-0 & LX-04-1 | American HE: HMX 85 & Viton A (Trademark of DuPont Co for vinylidene fluoride hexafluoropropylene polymer) 15%. <i>NOTE:</i> The "0" & "1" denote specifications for HMX particle size |
| LX-07-0 | HMX 90 & Viton A 10% |
| M1 Thickener | A standard thickener known as Napalm. It is a mixed aluminum soap in which ca 50% of the org acids are derived from coconut oil, 25% from naphthenic acids & 25% from oleic acid. When stirred into gasoline at a temp range from 16 to 29°C, M1 swells until the entire vol of gasoline becomes a more or less homogeneous gel [Ref: TM3-215/AFM 355-7 (Dec 1963),p41] |
| M2 Thickener | A standard (for Air Force only) incendiary oil thickener. It is an intimate mixt of M1 thickener 95 & devolatilized silica aerogel 5%. M2 thickener is an improvement over M1, not only because of free-flowing & faster setting characteristics, but also because the thickener itself & gel formed are more stable. It is used in fire bombs [Ref: TM 3-215/AFM 355-7 (Dec 1963), p 41] |
| M4 Thickener | A standard incendiary oil thickener. It is a diacid aluminum soap of isooctanoic acids derived from isooctyl alcohol or |

isooctyl aldehyde obtd from the oxidation of petroleum. It contains 2% of Santocel C or Attaclay SF which serves as an anti-agglomerant. About 1/2 the amt of M4 and about 1/10 mixing time is reqd for M4 thickener as compared to M1 thickener for fuels of comparable consistency. Fuels prepd with M4 thickener are superior in flame thrower firing performance with respect to range, burning & target effects, as compared with fuels prepd with other thickeners [Ref: **TM 3-215/AFM 355-7** (Dec 1963), p 41]

| | |
|----------------|--|
| MinSAT | Minimum Safe Air Travel. The shortest distance which a proximity fuze can travel thru the air without danger of causing detonation of a missile |
| MLA | Milled Lead Azide |
| MLSt | Milled Lead Styphnate |
| MP, SMRE | Ministry of Power, Safety in Mines Research Establishment, Buxton, England |
| Nike | US Army Surface-to-Air Guided Missile, including Nike-Ajax, Nike-Hercules & Nike-Zeus |
| NLSt | Normal Lead Styphnate with NC lacquer |
| NMEL or USNMEL | Navy (US) Marine Engineering Laboratory, Annapolis, Md 20910 |
| NONA | Nonanitroterphenyl |
| NOSC or USNOC | Naval (US) Ordnance Systems Command, US Navy Dept, Washington, DC |
| NP | Abbr for Napalm. Aluminum soap in powder form, used to gelatinize oil or gasoline for use in Napalm bombs or flame throwers. See also M1, M2 & M4 thickeners |
| NPP or USNPP | Naval (US) Propellant Plant, Indian Head, Md |
| NWL or USNWL | Naval (US) Weapons Laboratory, Dahlgren, Va |
| PBX-9010 | RDX 90 & KelF 10%(Chloro-trifluoroethylene polymer of MMM Co) |
| PBX-9011-02 | HMX 90 & Estane (Trademark of B.F. Goodrich Chemical Co for polyester urethane of adipic acid 1,4-butanediol, diphenyl methane diisocyanate) 10% |

XLIV

| | |
|---------------------------------------|--|
| PBX-9404-03 | HMX 94, NC 3 & Tris (β - chloroethyl)-phosphate 3%. The "03" denotes a bimodal particle size distribution of HMX |
| PL, SRI | Poulter Laboratories, Stanford Research Institute, Menlo Park, Calif |
| Plexiglas | A Trademark of Rohm & Haas Company for thermoplastic poly (methyl methacrylate)-type polymers |
| PMM | Polymethylmethacrylate |
| PT1 | A complex mixt based on "goop", a paste comprised of magnesium oxide, and carbon with a sufficient amt of petroleum distillate to form the paste. The following formula has been adopted as an oil & metal incendiary mix: Type C "goop" 49, IM polymer AE 3, coarse Mg 10, petroleum oil extract 3, gasoline 30 & NaNO_3 5% [Ref: TM 3-215/AFM 355-7 (Dec 1963), p 43] |
| PVA-LA | Designation of Lead Azide coated with 3% of polyvinyl alcohol (See Vol 1, p A558) |
| PVE | Pressure-Volume-Energy of an explosive's detonation products |
| RD-1333LA, RD1343LA & RD-1352LA | Designations of British Experimental Lead Azides (See Vol 1, p A559) |
| RF | Radiofrequency |
| RIND (FFA) | Research Institute of National Defense (Försvarets Forskningsanstalt), Stockholm 80, Sweden |
| RX-04-WT | HMX 88 & carborane-fluorocarbon copolymer 12% |
| RX-04-AV | HMX 92 & $(\text{CH}_2)_n$ (Polyethylene) 8% |
| RX-04-BY | HMX 86 & FNR (Tetrafluoroethylene-trifluoro nitroso methane copolymer) 14% |
| RX-04-P1 | HMX 80 & Viton A 20% |
| RX-05-AA | RDX 90, polystyrene 8 & DOPh (Diocetylphthalate) 2% |
| RX-09-AA | HMX 93.7, DNPA (Dinitropropylacrylate) 5.7 & EtDP (Ethyl-4,4-dinitropentanoate) 0.6% |

| | |
|-------------|--|
| SAM-D | US Surface-to-Air Defense Missile |
| SDRF | Swedish Detonic Research Foundation, Vinterviken, Stockholm SV, Sweden |
| Sidewinder | US Army Infrared Guided Missile |
| SIAM | Society of Industrial and Applied Mathematicians |
| SLA | British Service Lead Azide (See Vol 1, p A559) |
| SMPE-J | Society of Motion Picture Engineers, Journal of (changed to SMPTE-J) |
| SMPTE-J | Society of Motion Picture and Television Engineers, Journal of |
| SPRO, AGC | Solid Propellant Research Operations, Aerojet-General Corp, Sacramento, Calif |
| SRAM | US Air Force Short-Range Attack Missile |
| SRI | Stanford Research Institute, Menlo Park, Calif |
| Stabanate | A proprietary of Olin-Mathieson Chemical Co applied to the double salt of Lead Styphnate & Lead Nitroaminotetrazole. It was patented by E.A. Staba, USP 3310569 (1967) |
| Symp | Symposium |
| SympCombstn | Symposium on Combustion |
| SympDeton | Symposium on Detonation |
| TACOT | Tetranitrodibenzo-1,3a,4,6a-tetrazapentalene, $C_{12}H_4N_8O_8$, DuPont Co secondary expl, or Tetranitro-1,2,5,6-tetraza-dibenzocyclooctatetrene (Described in Vol 5 under Dibenzotetrazapentalene) |
| TATNB | 1,3,5-Triamino-2,4,6-trinitrobenzene [See AMCP 706-177 (March 1967), p 95] |
| TBI | Through Bulkhead Initiators |
| TeFDNE | Tetrafluorodinitroethane |
| TFENA | Trifluoroethyl Nitramine |
| TFTNA | 1,1,1-Trifluoro-3,5,5-trinitro-3-azahexane |

XLVI

| | |
|---------|--|
| TH1 | Designation of original Thermitite which is composed of ferric oxide 73 & fine granular aluminum 27% |
| TH3 | A superior incendiary for use in magnesium bombs. It consists of Thermitite (TH1) 68.7, Ba(NO ₃) ₂ 29.0, sulfur 2.0 & oil (binder) 0.3%. [Ref: TM 3-215/AFM 355-7 (Dec 1963), p43] |
| TH4 | A new Thermitite filling consists of: Iron oxide (magnetic) 51, Ba(NO ₃) ₂ 22, aluminum (granular) 19, aluminum (grained) 3 & polyester resin (Laminac 4116) 5% [Ref: TM 3-215/AFM 355-7 (Dec 1963), p 43] |
| USNMEL | See NMEL |
| USNOSC | See NOSC |
| USNWL | See NWL |
| Viton A | Trademark of DuPont Company for fluoroelastomers |
| X-0204 | HMX 83 & Teflon (Trademark of DuPont Co for tetrafluoroethylene polymer) 17% |

**SUPPLEMENT TO THE
LIST OF ABBREVIATIONS FOR BOOKS AND PERIODICALS
GIVEN IN VOL 1, pp Abbr 66 to Abbr 76; VOL 2, pp XI to XII
AND VOL 3, pp XII to XIII**

| | |
|---|--|
| Aerospace Sciences-J | Aerospace Sciences, Journal of |
| AIAA-J | American Institute of Aeronautics and Astronautics - Journal (Combining ARS-J and Aerospace Sciences, Journal of) |
| Andreev (1956) | K.K. Andreev, "Vzryv" (Explosion), Voenizdat, Moscow (1956); Andreev & Belyaev (1960). See Vol 3, pXII |
| ARS-J | American Rocket Society, Journal of the (Formerly Astronautics) (Merged with Aerospace Sciences, Journal of to form AIAA-J) |
| Baum, Stanyukovich & Shekhter (1959) | F.A. Baum, K.P. Stanyukovich & B.I. Shekhter, "Fizika Vzryva", (Physics of Explosion), FizMatGiz, Moscow (1959) |
| Blasters' Hdb (1958) | Abbrv for 1958 edition |
| Blasters' Hdb (1966) & (1969) | Blasters' Handbook, E.I. duPont de Nemours & Co, Wilmington, Del (1966) & (1969) |
| Burgess (1957) | E. Burgess "Guided Weapons", Macmillan Co, (1957), 253 pp |
| BurMinesBull 346 (1931) | C.E. Munroe & J.E. Tiffany, "Physical Testing of Explosives", USBureau of Mines Bulletin 346 (1931), USGovt Printing Office, Washington, DC |
| Clark & Hawley (1967) | G.L. Clark & G.G. Hawley, Edits, "The Chemical Encyclopedia", Reinhold, NY (1967) |
| 1st & 2nd SympCombstn (1965) | "Proceedings of the First and Second Symposia on Combustion", The Combustion Institute, Pittsburgh, Pa (1965), 353 pp First Symp held at 66th Meeting of ACS, Swampscott, Mass (10-14 Sept 1928) [Reprint of IEC 20, 998-1057 (1928)] Second Symp held at 94th Meeting of ACS, Rochester, NY (9-10 Sept 1937) [Reprint of ChemRev 21, 209-460 (1937) & 22, 1-310 (1938)] |
| 3rd SympCombstn (1949) | "Third Symposium on Combustion and Flame and Explosion Phenomena", University of Wisconsin, Madison, Wisconsin 7-11 Sept (1948), Williams & Wilkins, Baltimore, Md (1949), 748pp |

XLVIII

- 4th SympCombstn (1953) "Fourth Symposium (International) on Combustion (Combustion and Detonation Waves)" MIT, Cambridge, Mass, 1-5 Sept 1952; Williams & Wilkins, Baltimore, Md (1953), 926pp
- 5th SympCombstn (1955) "Fifth Symposium (International) on Combustion (Combustion in Engines and Combustion Kinetics)", University of Pittsburgh, Pittsburgh, Pa, 30 Aug-3 Sept 1954; Reinhold, NY (1955), 802pp
- 6th SympCombstn (1957) "Sixth Symposium (International) on Combustion", Yale University, New Haven, Conn, 19-24 Aug 1956, Reinhold, NY (1957), 943pp
- 7th SympCombstn (1959) "Seventh Symposium (International) on Combustion", London, England, 28 Aug-3 Sept 1958, Butterworths, London (1959), 959pp
- 8th SympCombstn (1962) "Eighth Symposium (International) on Combustion", California Institute of Technology, Pasadena, California, 28 Aug-3 Sept 1960, Williams & Wilkins, Baltimore, Md (1962), 1164pp
- 9th SympCombstn (1963) "Ninth Symposium (International) on Combustion", Cornell University, Ithaca, NY, 27 Aug-1 Sept 1963 Published by Academic Press, NY (1963)
- 10th SympCombstn (1964) "Tenth Symposium (International) on Combustion" Cambridge, England, 16-21 Aug (1964) (Pub 1965)
- 11th SympCombstn (1967) "Eleventh Symposium (International) on Combustion", Berkeley, Calif, 14-19 Aug 1966; The Combustion Institute, Pittsburgh, Pa (1967)
- 12th SympCombstn (1968) "Twelfth Symposium (International) on Combustion", University of Poitiers, Poitiers, France, 14-20 July 1968 (Pub 1969)
- Courant & Friedrichs (1948) R. Courant & K.O. Friedrichs, "Supersonic Flow & Shock Waves", Interscience, NY (1948)
- 1st ONR SympDeton (1951) "Proceedings - Conference on the Chemistry and Physics of Detonation", Office of Naval Research, Washington, DC (11-12 Jan 1951), 110pp
- 2nd ONR SympDeton (1955)
Vol 1 (Conf) & Vol 2 (U) "Second ONR Symposium on Detonation", Office of Naval Research, Washington, DC, 9-11 Feb (1955), Vol 1, 157pp; Vol 2, 502pp
-

XLIX

- 3rd ONR SympDeton (1960)
Vols 1 & 2 (U), Vol 3 (Conf) "Third ONR Symposium on Detonation", Princeton Univ, Princeton, NJ, 26-28 Sept (1960), Vol 1, 325pp; Vol 2, 333pp; Vol 3, 187pp
- 4th ONR SympDeton (1965) "Fourth Symposium (International) on Detonation", US Naval Ordnance Laboratory, White Oak, Maryland, 12-15 Oct (1965) 658pp
- Dunkle's Syllabus (1957-1958) C.G. Dunkle, "Detonation Phenomena", Picatinny Arsenal-Stevens Graduate School Program, 26 Syllabi (1957-1958) (Available from Defense Documentation Center, Cameron Station, Alexandria, Va as AD No 29041 (18 Jan 1962), PA Library Accession No U48378
- Dunkle's Syllabus (1960-1961) Ditto, Additions and Corrections to 1957-1958 Syllabus
- Elderfield 5 (1957) R.C. Elderfield, Edit, "Heterocyclic Compounds", Vol 5, "Five-Membered Heterocycles Containing Two Hetero Atoms and Their Benzo Derivatives", Wiley & Sons, NY (1957)
- Ellern, Pyrotechnics (1968) H. Ellern, "Military and Civilian Pyrotechnics", Chemical Pubg Co, NY (1968)
- Hirschfelder, Curtis & Bird (1954) J.O. Hirschfelder, C.F. Curtis & R.B. Bird, "Molecular Theory of Gases and Liquids", Wiley, NY (1954)
- Munroe & Tiffany (1931) C.E. Munroe & J.E. Tiffany, "Physical Testing of Explosives", USBurMines Bulletin 346(1931).
- Muraour (1947) H. Muraour, "Poudres et Explosifs", Presses Universitaires de France, Paris (1947)
- Newman (1943) James R. Newman, "The Tools of War", Doubleday, Doran & Co, Garden City, NY (1943), 398pp
- NOLR 1111 (1952) Collective, "Ordnance Explosive Train. Designers' Handbook", NOLR (Naval Ordnance Laboratory Report) 1111, USGovtPtgOff, Washington, DC (1952)
- PATR 1740, Ref 1 (1958)
[Now issued as AMC Pamphlet 706-177, US Army Materiel Command, Washington, DC (March 1967)] W.R. Tomlinson, Jr & O.E. Sheffield, "Properties of Explosives of Military Interest", PicArnsTechRept 1740, Revision 1 (1958)
- PATR 2145 (1945) B.T. Fedoroff et al, "Dictionary of Russian Ammunition and Weapons", PicArnsTechRept 2145(1955)
- PATR 2510 (1958) B.T. Fedoroff et al, "Dictionary of Explosives, Ammunition and Weapons" (German Section), PicArnsTechRept 2510 (1958)
-

L

- PATR 2700, Vol 1 (1960)
 PATR 2700, Vol 2 (1962)
 PATR 2700, Vol 3 (1966)
- Penner & Mullins (1959)
- Penner & Williams (1962)
- Robinson (1943)
- Robinson (1944)
- Sokolov (1937)
- Starling & Woodhall (1950)
- TM 9-1300-214/TO 11A-1-34
 (Nov 1967)
- Van Nostrand Dict (1953)
- Zel'dovich & Kompaneets (1955)
- Zel'dovich & Kompaneets (1960)
- B.T. Federoff & O.E. Sheffield, "Encyclopedia of Explosives and Related Items", PicArsnTechRept 1740, Vol 1 (1960), Vol 2 (1962) & Vol 3 (1966)
- S.S. Penner & B.P. Mullins, "Explosions, Detonations, Flammability and Ignition", Pergamon Press, NY (1959)
- S.S. Penner & F.A. Williams, eds, "Detonation and Two-Phase Flow", Vol 6 of "Progress in Astronautics and Rocketry", edited by M. Summerfield and published by Academic Press, NY (1962)
- C.S. Robinson, "Thermodynamics of Firearms", McGraw-Hill, NY (1943)
- C.S. Robinson, "Explosions, Their Anatomy and Destructiveness", McGraw-Hill, NY (1944)
- N.A. Sokolov, "Kurs Teorii Vzryvchatykh Veshchestv" (Course in Theory of Explosives), ONTI, Moscow (1937)
- S.G. Starling & A.J. Woodhall, "Physics", Longmans, Green & Co, NY (1950)
- New edition of TM 9-1910 (1955) (Listed in Vol 1 of Encycl, p Abbr 76)
- "The Van Nostrand Chemist's Dictionary", D. VanNostrand, NY (1953)
- Ya.B. Zel'dovich & A.S. Kompaneets, "Teoriya Detonatsii" (Theory of Detonation), Gostekhizdat, Moscow (1955)
- Ya.B. Zel'dovich & A.S. Kompaneets, "Theory of Detonation", Academic Press, NY (1960) (Translation from Russian edition of 1955)

**SUPPLEMENT TO THE
LIST OF BOOKS ON EXPLOSIVES AND PROPELLANTS
GIVEN IN VOL 1, p A676; VOL 2, pp C215 to C216 and VOL 3, pp XIV to XV**

- 1) W. Taylor, "Modern Explosives", The Royal Institute of Chemistry Monograph No 5, London, WC1 (1959) 63pp
 - 2) M. Barrère, et al, "Rocket Propulsion", Elsevier Pub Co, Amsterdam (1960) 862pp
 - 3) Ya.B. Zel'dovich & A.S. Kompaneets, "Theory of Detonation", Academic Press New York (1960) (Translation of Russian edition of 1955, which is listed in Vol 2, p C215-R, Ref 23)
 - 4) M. Summerfield, ed, "Progress in Astronautics and Rocketry", A Selection of Technical Papers Based Mainly on A Symposium of the American Rocket Society held at Palm Beach, Florida, April 26-28, 1961. Published by Academic Press, NY
 - Volume 1. M. Summerfield, ed, "Solid Propellants Rocket Research" (1960)
 - Volume 2. L. E. Bollinger et al, eds, "Liquid Rockets and Propellants" (1960)
 - Volume 3. N.W. Snyder, ed, "Energy Conversion for Space Power" (1961)
 - Volume 4. N.W. Snyder, ed, "Space Power Systems" (1961)
 - Volume 5. D.B. Langmuir et al, eds, "Electrostatic Propulsion" (1962)
 - Volume 6. S.S. Penner & F.A. Williams, eds, "Detonation and Two-Phase Flow" (1962)
 - Volume 7. F.R. Riddell, ed, "Hypersonic Flow Research" (1962)
 - Volume 8. R.E. Robertson & J.S. Farrior, eds, "Guidance and Control" (1962)
 - 5) A.J. Beardell and C.J. Grelecki, "Soviet Research and Development on the Chemistry of Compounds of Nitrogen Related to Propulsion", US Dept of Commerce, Office of Technical Services, Washington (1961) 61pp
 - 6) G. Glock, "Explosions-gefahren und Explosionsschutz in Betriebsstaetten", Verlag Chemie, Weinheim (1961)
 - 7) B. Lewis & G. von Elbe, "Combustion Flames and Explosion of Gases", Academic Press, NY (1961) 731pp
 - 8) G.F. Bal'shakov and E.A. Glesouskaya, "Geteroorganicheskie soedineniya reaktivnykh topliv", (Organic Propellants) GosNauchnTekhnIzdNeft i Gornolivn Prom, Leningr Otd, Leningrad (1962) 220pp
 - 9) J. Berger & J. Viard, "Physique des explosifs solides", H. Dunod et Cie, Paris (1962) 329pp
 - 10) S.L. Bragg, "Rocket Engines", Geo Newnes, London (1962) 158pp
 - 11) K.C. Brown and G.J. James, "Dust Explosions in Factories: A Review of the Literature", S.M.R.E., Ministry of Power, Sheffield, England (1962) 744pp
-

- 12) J.R. Muenger & L. Greiner, "Estimation of Performance Factors for Rocket Propellants", Texaco Inc, Beacon, NY (1962) 293pp
 - 13) S.S. Penner, "Chemical Rocket Propulsion and Combustion Research", Gordon and Breach, New York (1962) 158pp
 - 14) Anon, "Chemicals for Forest Fire Fighting", National Fire Protection Association, Boston, Mass (1963)
 - 15) Anon, "The Handling and Storage of Liquid Propellants", US Govt Printing Office, Washington, DC (1963) 338pp
 - 16) A.I. Gol'binder, "Laboratornye Raboty po Kursu Teorii Vzryvchatykh Veshchestv" (Laboratory Work for a Course in the Theory of Explosive Substances), Rosvuzizdat, Moscow (1963) 142pp
 - 17) W.C. Maurer, "Detonation of Ammonium Nitrate in Small Drill Holes", Colorado School of Mines, Golden (1963) 105pp
 - 18) M. Novotny & V. Pesata, "Teorie Prumyslovych Trhavin; Texty pro Ucastniky Post Gradualniko Kursu Trahaci a Vrtaci Techviky a Teorie Vybasin", StatniNaklTechLit, Prague (1963) 168pp
 - 19) E. Stuhlinger, "Electric Propulsion Development" (Progress in Astronautics and Aeronautics, Vol 9), Academic Press, NY (1963) 748pp
 - 20) B.V. Voltsekhovskii, V.V. Mitrofanov & M.E. Topchiyan, "Struktura Fronta Detonatsii v Gasakh" (The Structure of Detonation Fronts in Gases) IzdSibOtdAkadNauk, SSSR Novosibirsk (1963) 168pp
 - 21) Anon, "Flash Point Index of Trade Name Liquids", National Fire Protection Association, Boston, Mass, 6th ed (1964) 224pp
 - 22) Anon, "Manual of Hazardous Chemical Reactions", (NFPA No 491M) National Fire Protection Association, Boston, Mass (1964) 112pp
 - 23) E. Ring, A.A. Ezra, et al, eds, "Rocket Propellant and Pressurization Systems", Prentice-Hall, Englewood Cliffs, NJ (1964) 310pp
 - 24) B. Siegel & L. Schieler, "Energetics of Propellant Chemistry", Wiley, NY (1964) 240pp
 - 25) T. Urbański, "Chemistry and Technology of Explosives", Vol 1, Translated from Polish by Irena Jeczalikowa & Sylvia Laverton, Macmillan, NY (1964) 635pp
 - 26) T. Urbański, "Chemie und Technologie der Explosivstoffe, Band III", Translated from Czechoslovakian, VEB Deutscher Verlag fuer Grundstoffindustrie, Leipzig (1964) 527pp
-

- 27) Anon, "Code for the Storage of Ammonium Nitrate", (NFPA No 490-1965) National Fire Protection Association, Boston, Mass (1965) 20pp
 - 28) Anon, "Code for the Manufacture, Storage, Transportation and Use of Explosives and Blasting Agents", (NFPA No 495-1965) National Fire Protection Association, Boston Mass (1965) 45pp
 - 29) Anon, "Fire and Explosion Hazards of Peroxy Compounds", (ASTM Special Technical Publication, No 394) American Society for Testing and Materials, Philadelphia, Pennsylvania (1965) 24pp
 - 30) G.T. Carter, "Liquid Propellants Safety Handbook", CFSTI, Springfield, Virginia (1965) 106pp
 - 31) A.P. Cartwright, "The Dynamite Company: The Story of African Explosives and Chemical Industries Limited", Macdonald, London (1965) 267pp
 - 32) H.H. Freytag, ed, "Handbuch der Raumexplosionen", (Handbook of Explosions), Verlag Chemie, Weinheim (1965) 664pp
 - 33) R.M. Fristrom & A.A. Westenberg, "Flame Structure", (McGraw-Hill Series in Advanced Chemistry), McGraw, NY (1965) 424pp
 - 34) B.A. Gilmour (compiler), "Radiation Effects on Propellants and Explosives: An Annotated Bibliography", CFSTI, Springfield, Virginia (1965) 31pp
 - 35) M.R. Kantz, "Pentaerythritol Tetranitrate: A Bibliography", CFSTI, Springfield, Virginia (1965) 20pp
 - 36) R.R. Lenz, "Explosives and Bomb Disposal Guide", Thomas, Springfield, Illinois (1965) 303pp
 - 37) D.L. Turcotte, "Space Propulsion", Blaisdell, NY (1965) 146pp
 - 38) T. Urbański, "Chemistry and Technology of Explosives, Vol 2", Translated from Polish by W. Ornał & S. Laverton, Pergamon, Oxford, England (1965) 517pp
 - 39) P. Vantock, "Combustion Instability and Solid Propellant Rockets (Surveys of Soviet Scientific and Technical Literature)", Library of Congress, Aerospace Technology Division, Washington, DC (1965) 60pp
 - 40) Anon, "Hazardous Chemicals Data (National Fire Protection Association, No 49)", National Fire Protection Association, Boston, Mass (1966) 180pp
 - 41) Anon, "Flammable and Combustible Liquids Code (National Fire Protection Association No 30)", National Fire Protection Association, Boston, Mass (1966) 96pp
 - 42) K.K. Andreev, "Termicheskoe Razlozhenie i Gorenje Vzryvchatykh Veshchestv" (Thermal Decomposition and Combustion of Explosives), Nauka, Moscow, 2nd edit (1966) 345pp
-

- 43) S. Fordham, "High Explosives and Propellants", Pergamon Press, NY (1966) 236pp
 - 44) C.E. Gregory, "Explosives for Engineers: A Primer of Australasian Industrial Practice", Univ of Queensland Press, St Lucia, Australia, 2nd edit (1966) 145pp
 - 45) P. Hagenmuller, "Les Porpergols" (The Propergols), Gauthiers-Villars, Paris (1966) 92pp
 - 46) N.V. Mel'nikov & L.N. Marchenko, "Explosion Energy and Charge Design", CFSTI, Springfield, Virginia (1966) 149pp
 - 47) S.F. Samer, "Propellant Chemistry", Reinhold, NY (1966) 400pp
 - 48) B.E. Kleber & D. Birdsell, "The Chemical Warfare Service: Chemicals in Combat", US Government Printing Office, Washington, DC (1966) 697pp
 - 49) E. Venable, "Some Considerations of Fuel Gas Explosions", Chapter 19 in "Accident Reconstruction", J.W. Reed & R.A. Needham, edits, Dean-Hicks Co, USA (1966)
 - 50) R.I. Soloukhin, "Shock Waves and Detonations in Gases", (English translation from Russian), Mono Book Corp, Baltimore, Maryland (1966) 176pp
 - 51) E. Walski, "Liquid and Solid Propellants Technology (Surveys of Communist World Scientific and Technical Literature)", CFSTI, Springfield, Virginia (1966) 143pp
 - 52) S.A. Yantovskii, "Samovsplamnenie Gazov i Parov" (Self-ignition of Gases and Vapors), ONTI, Moscow (1966) 185pp
 - 53) Ya.B. Zel'dovich, M.A. Rivin & D.A. Frank-Kamenetskii, "Impulse of Reactive Force of Solid Propellant Rockets", CFSTI, Springfield, Va (1966) 194pp
 - 54) Anon, "Hazardous Chemicals Data 1967", National Fire Protection Association, Boston, Mass (1967) 196pp
 - 55) Anon, "Fire Protection Guide on Hazardous Materials", National Fire Protection Association, Boston, Mass (1967) 776pp
 - 56) A.C. Eringen, H. Leibowitz, S.L. Koh & J.M. Crowley, eds, "Mechanics and Chemistry of Solid Propellants", Pergamon, NY (1967) 627pp [Reviewed in *Nature* **214**, 1061 (1967)]
 - 57) M. Schorr & A.J. Zaehring, eds, "Solid Rocket Technology", Wiley, NY (1967) 337pp
 - 58) V.N. Sokol'skii, "Russian Solid-Fuel Rockets", CFSTI, Springfield, Va (1967) 236pp
-

- 59) T. Urbański, "Chemistry and Technology of Explosives, Vol 3", Translated from Polish by Marian Jurecki & Sylvia Laverton, Pergamon Press, Oxford, England (1967) 717pp
 - 60) R.L. Wilkins, "Theoretical Evaluation of Chemical Propellants", Prentice-Hall, Englewood Cliffs, NJ (1968) 436pp
 - 61) H. Ellern, "Military and Civilian Pyrotechnics", Chemical Pbg Co, NY (1968) 463pp
-

D

Alphabet letter D begins in Volume 3, p DI

DETONATION, EXPLOSION AND RELATED SUBJECTS

DETONATION AND EXPLOSION

Introduction. The existing books in English on detonation and explosion by Taylor (See Vol 2 of Encycl, p XII), Cook (See Vol 1, p Abbr 75), Penney & Mullins (See Abbr in this Volume), and Zel'dovich & Kompaneets (See under Abbreviations which precede this introduction), do not give a comprehensive description of all subjects related to detonation and explosion. In most cases there is too much mathematics in them and no clear definition of items. Since the alphabetical indices in the books of Taylor, Cook and Penner & Mullins are not very complete and since the book of Zel'dovich & Kompaneets has no index at all, it is difficult, in some cases to find the desired items

This write up attempts to cover in detail, without too much mathematics, all important items and subjects related to detonation and explosion. As in the other parts of this Encyclopedia, everything is arranged in alphabetical order

Section 1 lists those subjects from "Abel's Equation of State" to "Detonating Relays" which were either already described in Vols 1, 2 & 3 of this Encycl or have not been included

Section 2 covers subjects specifically related to Detonation and Explosion and have the word "Detonation" placed in front of them. *Section 3* describes Equations of State. *Section 4* Experimental Procedures, and remaining Sections contain subjects related to Detonation and Explosion in alphabetical order.

In compiling this work various journal articles, books, US Govt publications & reports and other sources of information were used. The work of C.G. Dunkle found in his Syllabus (1957/1958) issued in typewritten form by Picatinny Arsenal Library, Dover, NJ (Accession Number U48378) and Syllabus (1960-1961), contg additions and corrections to the earlier syllabus, were very helpful, especially for locating primary sources of information. Syllabus (1960-1961) can be obt'd as AD 290417 from the Defense Documentation Center, Defense Supply Agency, Cameron Station, Alexandria, Virginia, 22314. US Bureau of Mines

Progress Reports on Detonation, issued between 1948 & 1956 under Ordnance Corps Contracts, also covered important items on the subjects. We were not able to find final or summary reports of the USBurMines work

(Sections 1 and 2 which follow were prep'd in collaboration with Mr Cyrus G. Dunkle, physicist & expert on detonation, formerly of Picatinny Arsenal, now retired & residing in Silver Spring, Md 20910)

Section 1

Subjects Related to Detonation (and Explosion)

A

Abel Equation of State. See under Detonation (and Explosion), Equations of State

Abel Theory of Detonation. See under Detonation, Abel Theory

Ability to Propagate Detonation. See Vol 1, p VII

Ablation. See Vol 1 of Encycl, p A4-L

Ablation of High-Speed Particles in Air. See Cook (1958), 221-24

Absolute Reaction Rate of Eyring or Activated

Complex Theory, known also as *Transition State Theory.* See Absolute Rate Theory in Vol 1 of Encycl and in Cook (1958), p 134

Action of Gas Explosions on Solid Propellants. See Vol 1 of Encycl, p A98

Action of Shock and Explosion in Deformable Media. Engl transl'n of Rus book by G.I. Pokrovskii & I.S. Fedorov, "Deystviye Udara i Vzryva v Deformiruyemykh Sredakh", Prom-StroyIzdat, Moscow (1957)

Activated Complex Theory of Reaction Rates. Same as Absolute Rate Theory, described in Vol 1 of Encycl, p A4-R

Activation Energies of Explosives. See Vol 1, p A100

Active Oxygen in Explosives. See Vol 1, p A515-L

Adiabatic Compression of Entrapped Gas or Vapor as a Cause of Initiation of Explosives. See Vol 1, p A103-L

Adiabatic Decomposition of Explosives. See Cook (1958), pp 178-82

Adiabatic Explosion. See Vol 1, p A103

Adiabatic Flame Temperature. See Vol 1, p A103-R

Adiabatic Ignition of Propellants, Pyrotechnic Compositions, etc. See Vol 1, p A104-L

Adiabatic Shock Wave in a Propellant and Some HE's. (Studies are reported for the propellant contg 27% NG as well as for TNT, RDX and 50/50 - TNT/RDX by A.Ya. Apin et al, DoklAkadN **137**, 908-09 (1961) & CA **56**, 3712 (1962)

Advance Detonation. See Vol 1, p A105-R

Aeration of Explosives. It has been known for many years that sensitivity to initiation of gelatin-dynamites decreases with age and many investigators attributed this to the loss of air bubbles usually present in freshly made gelatins. This theory is known as "air-bubble theory", but there is also a theory advanced by Hargreaves, which attributes loss of sensitivity to other than air-bubble causes (See Vol 1 of Encycl, p A111-L, under Ageing of Dynamites). The fact that sensitivity of aged gelatin-dynamites can be restored by introducing air into them ("aeration"), as briefly discussed in Vol 1, p A111-L, shows that air-bubbles have something to do with sensitivity, although there might be some other factors affecting it

H.W. Clapham (quoted in Ref 1, p 160), prep'd simple gelatins by mixing NC with NG and allowing to gelatinize at 50° without

stirring, so that no air-bubbles would be introduced. When small diam cartridges were initiated by fulminate-chlorate detonators, they either failed to detonate or exhibited velocities of less than 900 m/sec. Mixts of identical compns, but prep'd with mechanical stirring, gave vels of the order 2000 m/sec, but occasionally of 7000 m/sec. He also has shown that the development of high deton vel of BG (Blasting Gelatin) was facilitated by a high degree of aeration, and if aeration were sufficient, high vel was achieved even in cartridges set off by No 6 fulminate-chlorate detonators. However, the high vel did not follow immediately on initiation of expln but occurred somewhat later

J. Taylor (Ref 1, p 161), investigated the effect of aeration on the development of high detonation velocity in BG within 4 inches of the origin of initiation, using fulminate-chlorate detonators. He found that there was a critical density (ca 1.46 g/cc) above which high deton vel did not occur. The density effect was one of aeration and only "creamy" mixes, with very fine air pockets, were effective in promoting high vels. As the fine air-bubbles coalesced on storage and the structure became coarser, the gelatins became increasingly insensitive

Summarizing the experience with BG, Taylor (Ref 1, p 163) stated that a "non-aerated" expl tended to fail in propagation of deton when initiated by weak detonators; well-aerated "creamy" mixes with extremely fine bubbles tended to detonate at, or pick up to high vel, and gelatins of intermediate aeration tended to exhibit the low-vel regime. It would appear that propagating low-vel is not achieved in small diam cartridges with non-aerated BG but that high-vel propagation can be obt'd with such material if a moderately powerful initiator is used

F.P. Bowden et al (quoted in Ref 1, p 172) have shown that the birth and growth of expls initiated by mechanical shocks in small quantities of material, is due to the formation of "hot spots" of finite size in the explosive and that from such hot spots explosion develops, probably by a self-heating

process. Effective hot spots can be produced in several ways but the following are the most important: a) boundary friction betw solids of high melting point (either contaminant or explosive) and b) adiabatic compression of minute gas or vapor pockets trapped in the expl during manuf or by aeration

The 2nd method is by far more sensitive, and extremely high temps can be achieved in gas pockets trapped in this manner [See also Birth and Growth of Explosion, etc in Vol 2 of Encycl, p B127-L and in this Volume under Detonation (and Explosion), Initiation (Birth), Growth Spread and Propagation in Explosive Substances]

Many experiments of H. Muraour et al (as quoted in Ref 1, pp 30-1) have shown that the light from deton is mainly emitted by the surrounding gas atm raised to a high temp by rapid compression and that the role of the gas phase in producing light is not confined to the environment but also to the gas occluded in the explosive. Granular expls produce more light than liquid or plastic expls. It has been shown recently that the principal part of the light arising from granular expls is derived from the compression of air pockets and not from the reaction itself (Ref 1, p 155)

Refs: 1) Taylor (1952), 30-1, 155, 160-61 & 172-73 2) Cook (1958), not found in index 3) Dunkle's Syllabus (1957-58), 159-62

After-, Post-, or Delayed-Reactions in Detonation. See Delayed-, After-, or Post-Reactions in Detonation

Air-Blast Effects. See Vol 2, p B180-R of Encycl under BLAST EFFECTS IN AIR, EARTH AND WATER

Air Gap Sensitiveness to Detonation (and Explosion). It is a term which has been applied to the maximum distance of the consistent propagation of detonation by influence from a primer charge across an air gap to a receptor charge. The air-gap test for sensitiveness has been used for many years as a control test for dynamites and other commercial expls.

In the case of mining expls, it provides a measure of probable borehole performance, ie, whether or not the expl may be depended upon to propagate in a long column under the confinement of the borehole (See also Detonation by Influence)

Ref: Cook (1958), 194-95

Note: There are several varieties of *Air-Gap Tests*, some of which were described in Vol 1 of Encycl, pp XIV-XV. Addnl refs are given under Detonation by Influence

Amplitude of Shock Waves. See under Detonation Waves and Shock Waves

Annular Detonation Wave. Davis et al (Ref 1) produced such waves on initiation with weak primers of cylindrical charges of cast TNT prep'd by pouring the molten expl into metal molds at RT. These waves originated at the surface of the chge, spread inward as they progressed, and finally coalesced over the entire width of charge. He found that the surface-chilled outer layer of cast was finely crystalline and that there was a progressive coarsening in size of crystal from the surface inward, and evidently the most sensitive regions were near the surface. Charges prep'd in heated molds had larger overall cryst size and less sensitivity (Ref 2)

Refs: 1) D.J. Davis et al, *Nature* **179**, 910-11 (1957) 2) Dunkle's Syllabus (1957-58), p 214

Anomalous High Velocity of Detonation.

Accdg to Baum et al (Ref), K.O. Friederichs observed during his experiments with sensitive HE's such as PETN, much higher detonation velocities than reported in the literature. He produced long, narrow charges of PETN by compressing well pulverized materials at 3000 kg/cm^2 ; then he broke the resulting bands into pieces 4-5 mm long and packed them loosely into a copper tube of 15 mm diam, thus obtg the overall density of 0.753 g/cc . When this chge was detonated, the velocity of 7924 m/sec was achieved and this was much higher than vel of 4740 m/sec corresponding to homogeneous chge of 0.753 g/cc density. A similar anomalous

behavior was observed for RDX, some initiating expls (like LA & MF), but not for expls of low sensitivity like TNT or PA

The following explanation of this behavior was given by Bobolev & Khariton. If lumps of material of 4-5 mm size are larger than critical diameter (such as for PETN is ca 0.9 and for RDX 1.2 mm) propagation will proceed not like in a solid front (as in homogeneous expls), but by a broken front. Each lump will detonate individually, creating the deton wave propagating at vel corresponding to density of lumps and not to overall density of chge. As density of lumps is high (ca 1.7), the velocity is also high. The anomalous velocity was not observed in TNT or PA, because the size of lumps was smaller than critical diameter of these expls. Accdng to Bobolev, critical diameter of TNT is 11.2 mm at $\rho_0 = 0.85$ and of PA 9.2 mm at $\rho_0 = 0.95$ g/cc (Ref, p 285) Ref: Baum, Stanyukovich & Shekhter (1959), 285-87

"Anomalous Thermoelectric Effect in the Shock Regime and Application to a Shock Pressure". Title of the paper by J. Crosnier et al in 4thONRSympDeton (1965), 627-38

Anomalous and Transient Wave Propagation is discussed in Cook (1958), 140-41

Antidetoning or Antiknock Compounds. See Vol 1 of Encycl, p A462-R

Apin's Theory of Detonation, known as *Penetrating, or Jet-Piercing Theory.* See under Detonation (and Explosion), Penetrating or Jet-Piercing Theory of Apin

Atomic Ammunition and Artillery. See Vol 1 of Encycl, pp A504-A505 under Atomic Weapons and Ammunition

Atomic (or Nuclear) Bomb. See Vol 1, p A499-L

Atomic (or Nuclear) Energy. See Vol 1, p A500-L

Atomic (or Nuclear) Explosions. See Vol 1, p A501-R, under Atomic (or Nuclear) Energy

Atomic (or Nuclear) Reactions. See Vol 1, p A501-L under Atomic (or Nuclear) Energy

Atomic Rockets. See Vol 1, p A504-R under Atomic Weapons and Ammunition

Atomic (or Nuclear) Weapons. See Vol 1, p A504-L

Attainment of Extremely High Temperatures in Detonation. See under Detonation (and Explosion), Temperatures of

Attenuation of Detonation (and Explosion). See under "Detonation (and Explosion), Attenuation, Break, Cutoff, Decay, Dying out, Fading and Failure of"

Autocatalytic Detonation (or Explosion). See Detonation (and Explosion), Autocatalytic

Auxoplosoe or Auxoplosophore. See Auxoplose in Vol 1 of Encycl, p A513-R

Available Energy in Detonation (and Explosion), also called Maximum Available Work Potential. See under "Detonation (and Explosion); Power, Available Energy (or Maximum Available Work Potential) and Strength in"

Available Oxygen. See Vol 1 of Encycl, p A515-L

Axial Initiation of Multi-Component Explosive Charges. Initiation of industrial expls (such as those based on AN) can be done by blasting caps (detonators) or boosters placed at one end of the charge or by one or several detonating fuses placed alongside or inside of the charge. The question is which of these methods gives the best efficiency? Cook et al (Refs 1, 2 & 4) claimed that a charge of Dynamite or of an HE is more completely detonated by a booster than by a detonating fuse. Sadwin & Stresau (Ref 3) claimed that only non-ideal deton was obtd when AN-Fuel expls were

centrally primed. Nevertheless, high-energy detonating fuses have been successfully used in quarry-blasting

In order to answer the question of efficiency more or less quantitatively, Deffet and Fosse' (Ref 7) conducted, in Belgium, tests by initiating by various methods AN-Fuel Oil (as well as RDX, AN/TNT/Al, etc) explosive cylindrical charges enclosed in Perspex containers. The method was similar to that used by Hershkowitz & Dalrymple (Ref 6) at Picatinny Arsenal, Dover, New Jersey. For axial initiation, the detonating fuse extended thru whole length of the charge, as shown in Fig 1

The propagation of detonation wave in the explosive was observed by means of flash-radiography. It was possible also to compare, in some cases, the pressure exerted on the confining Perspex walls as a function of the priming of the charge by photographing the shock wave in a Perspex block (Ref 7)

The curvature and the thickness of the normal compression wave was measured when the expl was initiated by a booster

When the expl was axially initiated, the detonation wave gradually developing along the axis of the detonating fuse, started to propagate at the velocity of the fuse. At the same time, another wave began to propagate laterally at a velocity which can be directly deduced from the value of the angle formed by the line tangent to the wave surface and the axis of the detonating fuse (Ref 2). The lateral propagation velocity,

V_L , can be calcd from the expression:

$$V_L = V_C \sin \beta$$

where V_C is detonation velocity of Cordeau (French for "detonating fuse") and β the angle which is indicated in Fig 2

The radiographs allowed one to find out how the velocity and the cylinder wall attack angle vary with the distance to the axis and consequently the diameter of the charge. They permitted also the observance of the shock wave in the Perspex block, but only when the charge was capable of releasing sufficiently high energy. During these experiments, the authors detd the relation between the pressure and the shock velocity in the Perspex using the classical shock relation:

$$P_s = \Delta DW$$

where Δ =density of Perspex (1.185 g/cc),
D=velocity of shock wave and
W=particle velocity which may, in first approximation, be detd from the expression:

$$W = (1/k)(D-C_0),$$

where $k=1.50$ and

C_0 =sound velocity (2,590 m/sec)

Shock waves were obtd in Perspex blocks drilled thru with different diameters (Fig 1). The shock wave which developed at the top of the block as well as in the ambient air in contact with the bottom of the same was photographed using the high-speed photography equipment of Cranz & Schardin, provided with explosive lamps of which the

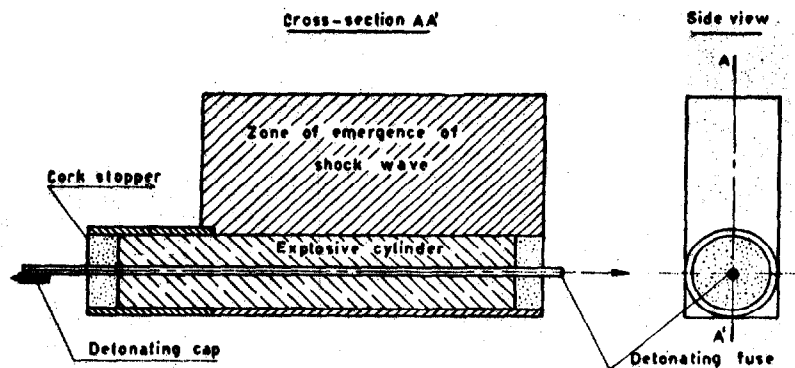

Fig 1 - Schematic view of experimental arrangement

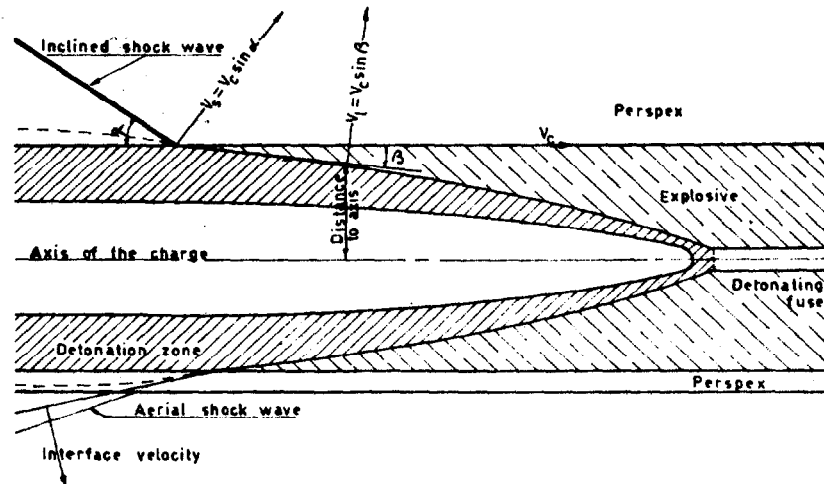

Fig 2 - Aspect of the detonation zone in explosive and the shock wave generated in surrounding medium

emission duration was ca 0.1 microsecond. The equipment was constructed at authors' laboratory at the Centre de Recherches pour l'Industrie des Produits Explosifs, near Brussels, by Vanden Berghe and described in Ref 5

The shock wave propagation or expansion velocity was calcd from the expression:

$$V_S = V_C \sin \alpha$$

in which V_C is the velocity component parallel to the axis of the chge (Fig 2), or by superimposing pictures obtd, for which the time-spacing is known with precision. Angle α is shown on the top left hand corner of Fig 2

After determining the properties of shock waves emerging in surrounding Perspex, they were used to evaluate the pressure effects on the walls of the charge. With normal sensitive expls such as RDX and granular 80/18/2-AN/TNT/Al, the detonating fuse running along the charge did not modify the wall pressure that was obtd when the chge was normally initiated at an extremity of the column, with a detonator; no significant difference was observed betw axial and normal initiation

As regards the low energy-low sensitivity expls of the AN/FO type, the axial priming with a high energy fuse (20 g/m) generated a reaction wave which attacked the wall of the cylinder in a direction nearly perpendi-

cular to it, especially when the cylindrical test block had a large inside diam. This can be considered as an advantage from the thrust point of view. Another advantage of axial initiation would result from a higher pressure exerted on the wall than with normal detonator or booster initiation. Unfortunately the pressure observed was not high and in some cases of axial initiation, the reactions were not complete

All this seems to mean that axial initiation does not give better results than normal initiation of charges provided they are strongly confined (Ref 7, p 165)

Refs: 1) M.A. Cook et al, 3rd Symp on Mining Research, Univ of Missouri, Rolla, Mo, Nov 14-15, 1957, Bull No 95 (1958) of the School of Mines and Metallurgy, p 155
2) Ibid, 5th Symp, Nov 19-20 (1959), Bull

98 (1960), p 50 3) L.D. Sadwin et al, 3rd-ONRSympDeton (1960), p 309 4) M.A. Cook et al, Ibid, p 357 5) L. Deffet & R. Vanden Berghe, Proc of 5th Int'l Congress on High Speed Photography, Washington, DC (1960), p 49 6) J. Hershkowitz & E.W. Dalrymple, PATR 3185 (1964) 7) L. Deffet & C. Fossé, 4thONRSympDeton (1965), 156-66

Azides, Thermochemistry of Explosive Azides was discussed by P. Gray & T.E. Waddington in *PrRoySoc* **235**, 106-10 (1956)

B

Backward Detonation and Retonation. *Backward detonation* was observed by Kendrew & Whitbread (Ref 2) during their investigation of transition from shock wave to detonation on 60/40 - RDX/TNT explosive. As this phenomenon is not too clearly defined in Ref 2 and it was confused by us with the "detonation in reverse", called "retonation" in Ref 3, Dunkle (Refs 4 & 5) clarified the subject by giving the following definitions:

"*Backward detonation* is a detonation which is delayed in developing, that is, it does not start until the shock from a donor, thru a barrier, has proceeded for a distance ("induction distance"), and then the detonation goes not only forward into fresh material but also "backward" into the shocked material"

A somewhat similar phenomenon in the DDT (deflagration-to-detonation transition) in combustible gas mixtures in cylindrical tubes is described in Ref 1 and is also called "retonation". Just behind the constant-velocity deflagration wave, shocks appear which follow at lower velocity, but new shocks originate successively closer to the wave and finally merge with it. At the transition, a high-velocity detonation wave starts forward into the unburned mixture, while a retonation wave starts back into the burned gases (Ref 5)

Although the word "reverse" might mean the same thing as "backward", the "detonation in the reverse direction", called *retonation* in Ref 2, is not identical with "backward detonation" of Ref 1 or the "retonation" of Ref 1

Retonation. In the phenomenon described in Ref 3 the initial shock is not strong enough to initiate the material but the reflected shock (being at a higher pressure) is strong enough so that detonation propagates backward from the *reflecting surface*, or from the collision of the front with another shock front proceeding in the opposite direction. (Such a head-on collision of two equal shocks has the same effect on each other as its reflection from a rigid wall)

Refs: 1) Progress Report No 3, Jan 1-Mar 31, 1954, Explosives and Physical Science Division, USBurMines, "Detonation and Explosives Phenomena" 2) E.L. Kendrew & E.G. Whitbread, "The Transition from Shock Wave to Detonation in 60/40 - RDX/TNT", 3rdONRSympDeton(1960), p 580 & Fig 4 on p 582 3) W.R. Marlow, "Retonation Caused by the Reflection of Divergent Waves", 4th-ONRSympDeton(1965), pp 426-31 4) C.G. Dunkle, private communication, Silver Spring, Md, 20910, July 4 and July 15, 1968 5) C.G. Dunkle, private communication, Aug 12, 1968

Backward Wave Propagation. Accdg to Cook (Ref 2), this is a wave propagating in both directions from the plane of initiation, each as high-order detonation. It was first observed in 1954 in the laboratory of Cook, Univ of Utah, and recorded photographically on some frames of sequence of the "shock pass-heat filter" (SPHF) initiation 2-inch diam Comp B. A similar phenomenon was observed in 1956 by Cosner & Sewell and described in conf rept (Ref 1) which was not used as a source of information

Refs: 1) L.N. Cosner & R.G.S. Sewell, NOTS, China Lake, Calif, June 1956 (Classified Wave-Shaping Conference at Pasadena, Calif) (listed as footnote on p 84-R of Ref 2) 2) Cook (1958), 84

Ballistic Measuring Methods and Ballistic Tests. See Vol 2 of Encycl, pp B5-R & B6-R

Ballistic Missile. See Vol 2, p B6-L

Ballistic Process of Conversion of an Explosive or Propellant. See under Detonative (or Explosive) Combustion

Ballistics. See Vol 2, p B7-L

Ballistograph. See Vol 2, p B10-L

Ball Lightning Explosion. It has been observed that sometimes during lightning there appear brilliant fiery balls which travel thru the air emitting unique hissing sounds and then violently exploding

Accdg to the theory proposed in Russia by Ya.I. Frenkel' & V.A. Belakon', a ball of lightning forms when an ordinary lightning bolt suddenly encounters an obstacle. When ordinary lightning travels thru the atmosphere, it consists of a flux of electrically charged particles (positive), which attract, on the outside, negatively charged particles. When this flux hits an obstacle its speed decelerates and the particles start to rotate thus forming a ring vortex which transforms into a ball of lightning. This consists of positively charged particles inside and negative particles outside, and they are kept separated by centrifugal forces. After traveling for a while, the rotation of the ball decelerates (due to the friction of ambient air) to the point when centrifugal forces become inadequate to hold the oppositely charged particles apart. Then a discharge takes place, accompanied by brilliant light, loud report and high temperature

Ref: G.I. Pokrovskii, "Vzryv" (Explosion), VoenIzdatMinistOborony, Moskva (1958); Engl excerpt entitled "Physics of Explosion", by Maj G.K. Kudravetz, USAF, OTIA 1450 (1958)

Note: On suggestion of C.G. Dunkle, the following is added:

1) BALL LIGHTNING, "A Collection of Soviet Research in English Translation", Edited and with an introduction and Annotated Bibliography Compiled by Donald J. Ritchie, Consultants Bureau, New York (1961)

Ball lightning usually appears near the end of a severe electrical storm (when the air is highly ionized and filled with electromagnetic disturbances caused by streak lightning). The balls may originate randomly in space, but are often seen in assocn with wire or structures; are frequently airborne wholly or partially, move randomly in space or along conductors, often have a rolling or spinning motion; are usually about 10 inches in diam; are usually spherical but may have a doughnut or ring shape; are very rarely green or violet in color but are frequently multicolored (the white and blue-white balls are usually very hot and brilliant and often cause considerable damage); last on

the average about 3 or 4 seconds, usually decay suddenly (sometimes explosively); and generally do not affect the vision unless they are of the white or blue-white category and close to the observer

The rolling, spinning, or tumbling motion frequently reported suggests rotational *plasma* or mass flow and the possibility of an internal current or vortex. It is estd that the surface temp can be as high as 9000° F and that much energy is released on the decay - perhaps as much as 10^6 joules, equivalent to 48 lbs of TNT. In general, lightning strokes may involve up to 164 coulombs, up to several gigavolts and up to about 20 gigajoules. Most strokes have currents of less than 10000 amps, but on rare occasions have been reported to have more than 200000 amps

Mechanisms such as the brush light arc, the charged water bubble, afterglow phenomena, and diffusion combustion of small gas admixts in air have been suggested, and explain one or more features of the phenomenon but fail to explain others. High-frequency electrodeless discharges have some of its features. It has been suggested that ball lightning is a ring current, or toroidal configuration of currents as high as 200000 amps. Such a form would have high magnetic pressures, which could completely offset and balance the internal pressure of the ionized gas. Such a theory, of course, must resolve the problems of instability assocd with such current flow and magnetic fields. An understanding of the physical principles underlying the ball lightning phenomenon may be applicable to the production of thermonuclear power

2) "ATTEMPTED EXPLANATIONS OF BALL LIGHTNING", Edmond M. Dewan, Air Force Cambridge Research Laboratories Report **AFCL-64-927** (November 1964) (Physical Sciences Research Paper No 67)

This gives a critical resumé of, and lists the shortcomings of, previous theories. Features of ball lightning (BL) which any valid theory must explain, are listed. A new theory is evaluated which was conceived and worked out under a grant supplied by

this lab. The final report from Yeshiva Univ on this grant is given by Finkelstein and Rubenstein, Ball Lightning, Physical Review **135** (1965), p A390. Briefly, the theory says that BL is a dc nonlinear phenomenon. If a dielectric inhomogeneity is introduced into a uniform dc elec field (such as exists over sizable regions between a thunder cloud and the ground) one can show that there is a tendency for lines of force to concentrate within the inhomogeneity. A conducting inhomogeneity would also tend to concentrate lines of force toward it, but of course would have little field within its vol. If the field were high enough, and the focusing effect great enough, it would be possible to have a local breakdown giving rise to a localized discharge of *plasma*. Such a plasma would itself be an inhomogeneity of high conductance. This in turn would further concentrate lines of force which would in turn increase the plasma's vol. The feedback cycle would continue until a stable size is reached where there is a max concn of energy in the field surrounding the plasma. In a word, the theory says that BL is a corona discharge in midair

This theory can be shown to meet all of the requirements. However, there are objections arising from a few observations. A modification which might answer these objections is the replacement of the dc field by an ac field. Even a 60-cycle field would be adequate. However, the Finkelstein-Rubenstein theory, as it now stands, is strictly a static one, and further theoretical work might be required to establish the equations governing ac confinement. What is proposed is really a development of the theory in the direction towards (but not all the way to) the theories of Kapitza and Cerillo

Ball lightning and other "far-out" devices are discussed in a SECRET report: "THE STUDY OF ADVANCED LETHAL MECHANISMS" (U), IIT Research Institute Summary Report for Warhead and Special Projects Laboratory, Picatinny Arsenal, Dover, NJ (completed Apr 1964) by Milton S. Nusbaum

See also "Lightning in Orbit" (Strategy, Rockets, Space) Col V. Glazov and Eng Col V. Vaneev, translated from **Red Star**, USSR Army newspaper, January 19, 1963, by B.W. Kuvshinoff

Bare (or Unconfined) Charges, Blast from. See Vol 2, p B180-R, under Blast Effects in Air

Barricades in Explosives and Ammunition Installations. See Vol 2 of Encycl, p B22-R and Dunkle's Syllabus (1957-58), pp 371-72

Barrier Tests and Their Comparison with Shooting Tests. In the *shooting test*, a cylindrical projectile of Al, steel, etc is shot against a cylindrical sample of explosive in such a manner that one of the plane surfaces of projectile strikes a plane surface of the expl sample. The pressure developed on coaxial impact can be calcd from the expression:

$$p = (W_e \rho_e v) / (1 + \frac{W_e \rho_e}{W \rho})$$

where: W = shock front velocity in the projectile;

W_e = shock front velocity in the expl sample;

ρ and ρ_e = corresponding densities, and
 v = velocity of projectile before impact.

The pressure remains constant until the arrival of the first reflection wave in the projectile

In the tests conducted by Lundborg (Ref 6), the projectile was an Al cylinder 15 mm in diam and 15 mm in length which was fired with $v = 650$ m/sec against pressed TNT sample, $\rho_e = 1.55$ g/cc, of the same diam as Al proj. Fig 1, p 432, reproduced here shows the pressure-time (initiation delay) relationship

A minimum (critical) velocity of projectile was found to be lower than for corresponding barrier test

In the *barrier test*, a cylindrical sample of explosive is separated from a charge of expl known as *donor* by a *barrier*, which is a thick disk of Al, brass or other metal. In this test, the donor creates a shock wave in the barrier, which in turn gives rise to an impact pressure at the contact surface

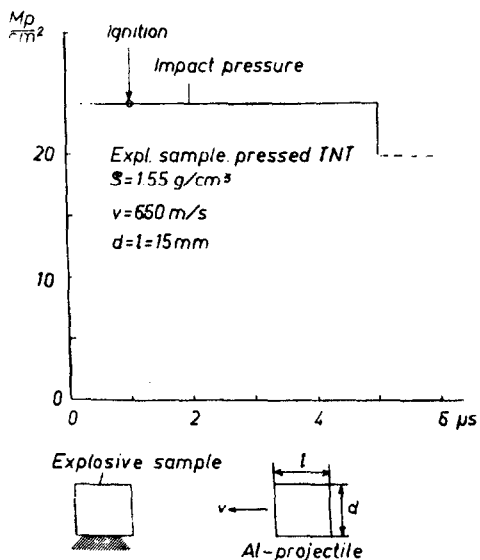

Fig 1 - Shooting test

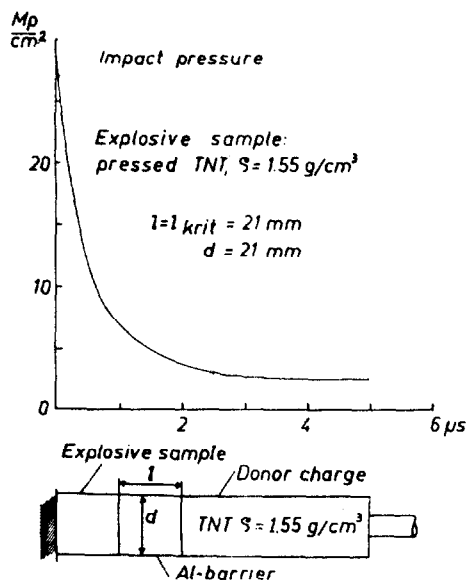

Fig 2 - Barrier test

between the barrier and the expl sample. The donor can be initiated by an appropriate detonator

In the tests conducted by Lundborg, an expl sample (TNT or other HE) was placed against an Al barrier, as shown in Fig 2, p 433 of Ref 6 and reproduced here. The donor was pressed TNT of $\rho_0 = 1.55 \text{ g/cc}$. This Fig also shows the pressure-time diagram for donor and sample of pressed TNT, 21 mm in diam & 25 mm long, and an Al-barrier 21 mm in diam at the critical length of 21 mm. The pressure was not constant but fell rapidly with the time.

The test was repeated using cast TNT and pressed PETN+10% wax with the same kind of donor and barrier

Comparing the shooting- with barrier test, Lundborg found that a linear relationship exists betw critical velocity of Al projectile ($d=15 \text{ mm}$) and length of Al barrier ($d=21 \text{ mm}$). This confirmed results previously reported in Refs 1-5

Table 1, p 433 of Ref 6 gives critical lengths of 21 mm Al barriers and critical velocities of 15 mm Al projectiles against 25 mm long samples

Table 1

| Explosive | State | Density (g/cc) | Barrier Length (mm) | Proj Vel (m/sec) |
|-----------|---------|----------------|---------------------|------------------|
| TNT | cast | 1.60 | 3-4 | 1500 |
| TNT | pressed | 1.54 | 20-21 | -1720 |
| PETN | pressed | 1.33 | 28-29 | 290 |
| +10% wax | | | | -340 |

Fig 3 gives relation between projectile velocity and barrier length

Another way was to compare the critical projectile velocity with the end velocity of the barrier at the critical length. The latter was determined with an Al-plate 1 mm thick and 13.7 mm in diam on the end surface of the Al barrier (Fig 4) and the time betw two wire-contacts at a distance of 100 mm was measured. It was found that the particle velocity attenuates logarithmically with the barrier length. End velocities at various barrier lengths are given in Fig 4, and in Table 2 of Ref 6. For example, for barrier length of 5 mm end velocity is 1890 m/sec,

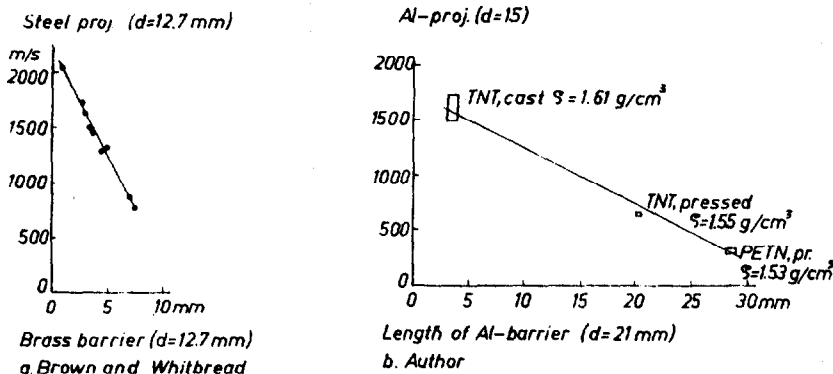

Fig 3 - Relation between projectile velocity and barrier length

for 6 mm - 1820, for 11 mm - 1320, for 16 mm - 960, for 21 mm - 650-700 and for 31 mm - 410 m/sec

Extrapolation in Fig 4 to a barrier length of 2 mm gave end velocity of 2400 m/sec and to the length of 0 mm gave 2600 m/sec. The shock front velocity for Al is ca 6200 m/sec, and by inserting 2700 kg/m^3 for the density 217 kbars was obtd for the shock wave pressure. Fig 5 shows the critical vel of Al projs as a function of the end vel of Al-barriers at a critical length. The dotted line indicates the uncertainty along the two axes

Refs: 1) S.M. Brown & E.G. Whitbread, CollIntrnlCentreNatlRechScientSaint-Louis, France, 28 Aug-2 Sept, 1961 (Shooting and barrier tests) 2) C.H. Johansson & T.

Sjölin, Explosivst 9, 165 (1961) (Barrier test) 3) Ibid, Arkiv för Fysik, Stockholm 24, 559 (1963) (Barrier test) 4) E. Eldth et al, Explosivst 11, 97 (1963) (Shooting test) 5) N. Lundborg, Explosivst 12, 269 (1964) (Barrier and shooting tests) 6) N. Lundborg, 4thONRSympDeton(1965), 432-34 (Comparison between shooting and barrier tests).

Behavior of Detonation, Study of. It was discussed by M.H. Boyer et al, in Pubs Nos U187(1958) and U369(1959) of Aeronautics Systems Inc, Ford Motor Co, US Navy Contract NOrd 17945 (1958)

"Behavior of Explosives at Impulsively Induced High Rates of Strain" was discussed by H.S. Napadensky et al at the 3rdONRSymp-Deton, Vol 2, pp 420-35 (1960)

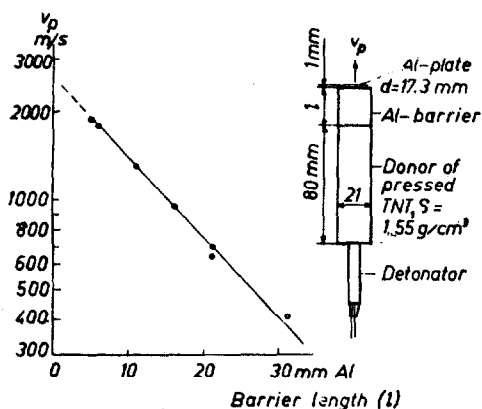

Fig 4 - End velocity at different barrier lengths

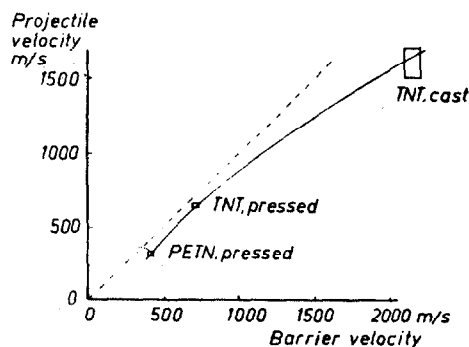

Fig 5 - Relation between critical projectile and barrier velocity

"*Behavior of Explosive Systems Under Mild Impact*", Title of the paper by J.E. Kennedy & H.S. Napadensky, in IIT Research Institute, Chicago, Illinois, **DASA 1801** (1966)

Behavior of Explosives at Very High Temperatures. This subject was discussed by J. Wenograd at the 3rdONRSympDeton, Vol 1, pp 60-76(1960) and also in TrFaradSoc **57**, 1612-20(1961) & CA **56**, 11872(1962)

Berthelot's Characteristic Product. See Vol 2, pp B105-L to B106-L

Berthelot's Theory of Detonation. See Vol 2 of Encycl, p B106-L

Bichel Calorimetric Bomb. See Vol 2, p B111-R

Binding Energy. See Vol 1, p A500-R under Atomic (or Nuclear) Energy

Birth (Initiation) and Growth of Explosion in Solid and Liquid Explosives Initiated by Impact, Friction, etc. See Vol 2, p B127-L and under Detonation (and Explosion), Initiation (Birth), Growth, Spread and Propagation in Explosive Substances

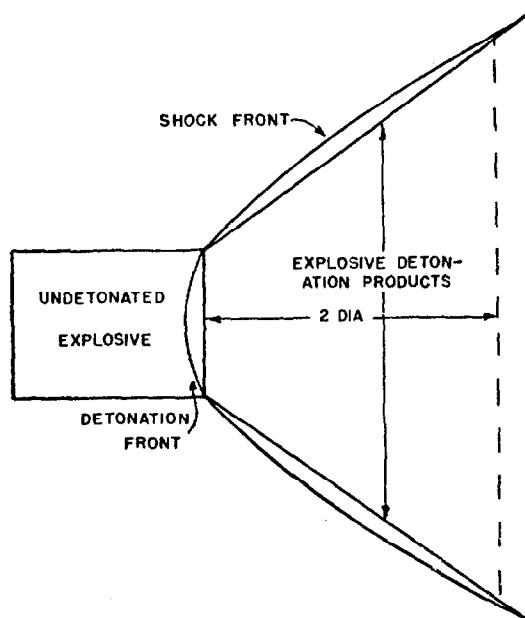

Figure 5.11 Cross-sectional diagram of a blast contour in air

Blast. See Vol 2 of Encycl, p B180-L

Blast Contours. This subject was discussed by Cook (1958), pp 106-14 and many photographs of contours are given. In Fig 5.11, which is reproduced here, is given a cross-sectional diagram of a blast contour in air and in Fig 5.13 a blast contour diagram of wave emerging from -6+8 mesh TNT, 5 cm in diam

Blast Effect in Air, Earth and Water. See Vol 2, pp B180-B184, Cook (1958), pp 106-13 & 353-75, and Dunkle's Syllabus (1957-58), p 311)

Blast Effects Due to Reflected Shock Waves. See Vol 2, p B182-L

Blast Effectiveness of Various Explosives. See Vol 2, p B182, Table giving Peak Pressure and Effectiveness Against Load-Bearing Wall

Blasting Action of High Explosives in Relation to Their Explosive Properties. See Cook (1958), Chap 11, pp 265-82 (9 refs)

Blast Meters. See Vol 2, p B214-R

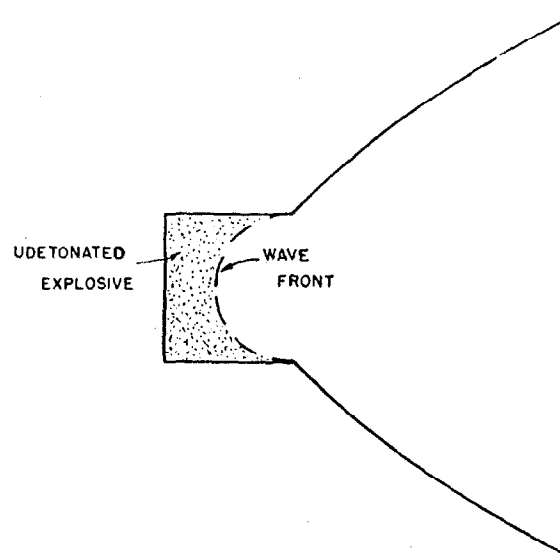

Figure 5.13 Blast-contour diagram of wave emerging from -6+8 mesh TNT ($d = 5$ cm)

Blast Potential. See Damage Potential of Air and Ground Blast Waves in Vol 3, p D3-R

Blast, Spherical. When a spherical explosive charge is detonated in air, underground, or underwater it produces waves which are spherical in shape. Such waves can also emerge from the end of an unconfined cylindrical charge, as described by Cook (1958), pp 100-01 (See also Fig on p B183 of Vol 2)

Blast, Spherical, Its Initial Propagation from Certain Explosives is discussed by F.J. Berry & M. Holt in *PrRoySoc* 224A, 236-51 (1951). Also discussed in *ARE Repts* 6/54 & 33/54 (1954)

Blast Wave, also known as *Burst Wave*, and sometimes called *Pressure Wave*. See Vol 2, p B181-L under BLAST EFFECTS IN AIR, EARTH AND WATER and also in Cook (1958), pp 324-27 (Pressure wave) & Chapter 14

Blast Wave, Damage Potential of Air and Ground, was discussed by Cook (1958), pp 353-75

Blast Wave Pressure Measurements are discussed by: A) H. Yamazaki et al in *Kôgyô-KayakuKyôkaishi* 25 (1), 22-4 (1964); *CA* 62, 12965 (1965) and B) Y. Mizushima, *KKK* 26 (3), 142-55 (1965) & *CA* 64, 3274-75 (1966) (42 refs)

BMPT (Birkhoff-MacDougall-Pugh-Taylor) Theory of Jet Formation in Lined Shaped Charges. See Detonation; *BMPT (Birkhoff-MacDougall-Pugh-Taylor) Theory of Jet Formation in Shaped Charges*

Boltzmann Constant. A molecular constant arising in thermodynamic calculation of the energy of a single molecule or oscillator. It is expressed by the relationship $k=R/N$, in which R is the "gas constant" (1.9885 cal or 8.316 joules per °C) and N is "Avogadro number" (the number of molecules contd in one mole = 6.062×10^{23}). The value of k is given in Ref 8, p 90 as 1.380×10^{-16} erg per °C

Boltzmann Equation of State and Its Modification by Hirschfelder & Roseveve. See under Detonation (and Explosion), Equations of State

Bomb, Manometric. See Vol 2, p B224-R

Break Character of Detonation (and Explosion). See Detonation (and Explosion), Break, Character of

Break of Detonation. See under Detonation; Attenuation, Break, Cutoff, Decay, Dying-out, Extinction, Fadeout, Fading and Failure of

Breaking Force in Detonation. See under Breaking Theory of Detonation in Vol 2 of *Encycl*, p B362 and in this section under "Detonation (and Explosion), Breaking Theory of Carl"

Breaking Theory of Detonation of Carl. See under Detonation (and Explosion), Breaking Theory of Carl

Break-Up of Solids by Detonation (and Explosion). See under Deformation and Break-Up of Solids by Detonation (and Explosion) in this section

Bremstrahlung (Ger for Retarding Radiation or Retardation Radiation). Such retardation of radiation is produced when electrons are deflected by ions. Since this is a deceleration, it represents a loss of energy by the retarding material

Ref: Dunkle's Syllabus (1958), p 396

Brisance (or Shattering Effect). See Vol 2 of *Encycl*, pp B265-B297 and Dunkle's Lecture delivered at PicArson in 1955, p 12

To this may be added the following information supplied by C.G. Dunkle in private communication from Silver Spring, Maryland, Jan 15, 1964

The product of the available energy and the detonation velocity can be taken as a measure of brisance (shattering power). Since, in comparison of different expls with respect to this property, the deton velocity seems to have the greater weight of the two

factors. Brisance has been characterized also by the product of the available energy and the square of deton velocity. This relates closely to the detonation pressure which can be expressed by the formula:

$$P = \rho D^2 / (\gamma + 1)$$

where: ρ = the loading density,
 D = deton velocity, and
 γ = the polytropic exponent of the
 deton products

In fact Schmidt (as quoted by J.F. Roth, *Explosivst* 1957, 162) spoke of detonation pressure as a measure of brisance

Dunkle also discussed calcn of brisance by Kast's formula. This method was described in Vol 2 of *Encycl*, p B265-R

A detailed discussion on brisance was given in the Russian book of Baum, Stanyukovich & Shekhter (1959), pp 428-52 and a brief description was given by Andreev & Belyaev (1960), p 476-81

Brisance, Correlation with Chemical Structure.

Accdg to Lothrop & Handrick (Ref 1, p 423 & Ref 2, p 267), brisance (also called shattering effect) and impetus (also called power, force or strength) are directly related to oxygen balance for primary phosphoric compds (nitrate esters, aromatic nitro-, aliphatic nitro- and nitramines), while for secondary phosphores (azo-, azido-, nitroso-amino-, nitroso-, peroxides, ozonides and perchlorates) an increase in oxygen balance is less likely to enhance the impetus. Most secondary phosphores are inferior to primary phosphores for increasing impetus; but they may be useful for imparting other desirable qualities, such as sensitivity. They must, however, be avoided if impetus and brisance alone are criteria

Plate dent values for brisance when plotted against ballistic mortar values for impetus seem to agree completely with sand test data and when plotted against ballistic mortar values give a straight line regardless of the presence of phosphores or auxophores, thus showing that impetus and brisance vary simultaneously in the same direction. There seems to be a functional relationship of impetus and brisance

to the heat of explosion (Ref 2, p 268)

Concerning brisance and impetus, L & H (Ref 1, pp 421-22 & Ref 2, p 267) suggest that whether the lead block test is a measure of impetus or of an uncertain combination of impetus and brisance, while a subject of contention, is not of great importance in view of the tendency of impetus and brisance to vary concomitantly. They consider, however, that it is probably safer to use the ballistic mortar values in direct comparison of available energy

Refs: 1) W.C. Lothrop & G.R. Handrick, *Chem-Revs* 44, 421-23 (1949) 2) Dunkle's *Syllabus* (1957-1958), 267-68

Brisance, Correlation with Detonation Velocity. See Vol 2 of *Encycl*, p B297-L and Table II, p B298

Brisance, Correlation with Properties Other Than Chemical.

Accdg to remarks of C.G. Dunkle made during proceedings of the 4th ONRSympDeton (1965), p 13, brisance defined as "shattering power" has been thought to depend on quantity of energy evolved and the speed of its liberation. Attempts have been made to correlate brisance with deton velocity, energy and pressure, without much more success than by the various small scale tests, such as sand test, small scale push test etc (See also Vol 1 of *Encycl*, pp VIII-IX and Vol 2, pp B299-B300)

Defining brisance as the *ability of an explosive to impart energy to metal or accelerate it*, makes it possible to measure brisance quantitatively, and clarifies the roles of both detonation energy and detonation pressure. "Shattering power" is an indirect effect of high values of these parameters which, as shown by some papers, lead to generation of strong shock waves with spalling and other destructive effects on confining metals

A method for quantitative determination of brisance is described in the next item

Brisance, Determination by Method of Metal Acceleration by Explosives.

Kury et al (Ref 7) developed an accurate hydrodynamic test to measure relative metal accelerating

ability, and results have been obtained for a number of explosions. Of the various existing metal accelerating tests, such as *sphere test* (Ref 5), *plate push test* (Ref 1), *flat plate test* (Ref 3) and *cylinder test* (Ref 3), Kury et al (Ref 7) consider the **cylinder test** to be the most versatile for determining relative performance. The test was developed by Kury et al in 1960 and described in conference paper (Ref 3) which was not used as a source of information. The test was later improved and its modified version was described in unclassified Ref 7.

The new variant is as follows: Copper cylinders 25.4 mm (or 50.8 mm) diam & 12 inches long, of various thicknesses, were filled with HE's to test. A plane wave lens and Comp B, Grade A (64/36-RDX/TNT) Booster was used to initiate the explosion at one end. The radial motion of the cylinder wall was measured in a plane perpendicular to the cylinder axis 7 inches from the booster end. A streak camera recorded the motion, using conventional shadowgraph technique (See under CAMERAS, HIGH-SPEED PHOTOGRAPHIC in Vol 2 of Encycl, p C13-L). In addition, the detonation velocity of the explosion was measured by placing pin switches 9-in apart on the surface of the cylinder, as described, for example, by Cook (Ref 2, p 29). The streak camera record was read on a precision comparator which punched out the data directly on IBM cards. A computer code con-

verted film coordinates into actual radius (R) & time (t), fitted the data, and calculated radial wall position & velocity (D) at specified values of $R-R_0$, where R_0 is initial radius. Reproducibility of radius-time data between duplicate experiments was better than 0.5%

Table 1, p 4 of Ref 7, entitled "Radius-Time History of Copper Cylinders Expanded by Comp B, Grade A", presents time (t) of expansion at various $R-R_0$ values, of which some examples are given

Table 1

| 25.4-mm diam Comp B. Cu Wall 2.606-mm Thick | | 50.8-mm diam Comp B. Cu Wall 5.21-mm Thick | |
|---|-------------------|--|---------------------|
| $R-R_0$ (mm) | t (μ sec) | $R-R_0$ (mm) | t/2 (μ sec) |
| 2 | 2.17 | 4 | 2.15 |
| 4 | 3.77 | 4 | 3.78 |
| 5 | 4.51 | 10 | 4.51 |
| 8 | 6.59 | 16 | 6.59 |
| 10 | 7.92 | 20 | 7.92 |
| 14 | 10.50 | 28 | 10.48 |
| 18 | 12.99 | 36 | 12.97 |
| 19 | 13.60 | 38 | 13.59 |
| 23 | 16.04 | 46 | 16.02 |

Table 2, p 5 of Ref 7, entitled "Cylinder Test Results", shows density, detonation velocities and cylinder wall velocities for various pure and mixed HE's. Our table 2 gives some selected values

Table 2

| Explosive | Density g/cc | Detonation Velocity (mm/ μ sec) | Cylinder Wall Velocity (mm/ μ sec) | |
|-----------------------------|----------------------------|---|--|-----------------------|
| | | | At $R-R_0 =$ 5 mm | At $R-R_0 =$ 19 mm |
| Comp B (64/36-RDX/TNT) | 1.717 | 7.99 | 1.39 | 1.63 |
| Cyclotol (77/23-RDX/TNT) | 1.754 | 8.25 | 1.46 | 1.70 |
| HMX | 1.891 | 9.11 | 1.65 | 1.86 |
| N Me | 1.413 | 6.37 | 1.01 | 1.22 |
| Octol (78/22-HMX/TNT) | 1.821 | 8.48 | 1.53 | 1.75 |
| PETN | 1.765 | 8.16 | 1.56 | 1.79 |
| RDX | Evidently not investigated | | | |
| TNT | 1.630 | 6.94 | 1.18 | 1.40 |

NOTES:

I. Since Kury et al did not explain, how they detd cylinder wall velocity, it was assumed by senior author BTF that it was obtd for Comp B, for example, by dividing $R-R_0=5$ mm by 4.51. As this gave only 1.11 μ sec instead of 1.39 given in Table 2, we needed some explanation. This was supplied by Dunkle (Ref 8), who stated that "velocity is not constant but is accelerating" and the value 1.39 μ sec for Comp B is evidently "instantaneous" velocity at $R=5$ mm and is close to average vel 1.35 μ sec over interval $R-R_0=5-4=1$ mm, obtd by dividing 1 by $(4.51-3.77=0.71)$

II. If brisance is judged by wall velocity, then HMX has the highest brisance, while that of TNT is the lowest

Table 3, p 5 of Ref 7, entitled "Relative Metal Accelerating Ability", presents relative energy delivered to metal in geometries characterized by head-on detonations (A) and in geometries characterized by sideways detonations (B)

Table 3

| Explosive | Relative Energy Delivered to Metal | |
|-----------|------------------------------------|------|
| | A | B |
| Comp B | 1.0 | 1.0 |
| Cyclotol | 1.10 | 1.09 |
| HMX | 1.41 | 1.30 |
| NMe | 0.53 | 0.56 |
| Octol | 1.21 | 1.15 |
| PETN | 1.26 | 1.21 |
| TNT | 0.72 | 0.74 |

The ability to calculate the performance of a system contg explosive and metal has, in general, been limited before the advent of computers such as IBM 7030 and CDC 6600, to simple idealized geometries. With these computers, however, the motion of metal in fairly complex geometries can now be accurately calcd using such hydrodynamic codes as HEMP, previously described by Wilkins (Ref 4) (See also Ref 6). For doing this, it is necessary to have an accurate description of P-V-E (pressure-volume-energy) behavior of an explosive's detonation products. After investigating several equations of state (such as of Becker-Kistiakowsky-Wilson; Lennard-Jones & Devonshire and of Wilkins) [See under

"Detonation (and Explosion), Equations of State"]. Kury et al came to the conclusion that, on introducing an extra term into Wilkins equation, they can obtain a modification which is suitable for a range of pressures 1 to 500 kbar and which gives results in fairly good agreement with exptl values. Their equation is described in item Z, under "Detonation, Equations of State in"

"Relative performance" of various HE's was predicted by Kury et al (Ref 7, p 11) on calcn using Becker-Kistiakowsky-Wilson equation in a thermodynamic-hydrodynamic code, such as RUBY (qv). To do this the energy release (ΔE) for the reaction:

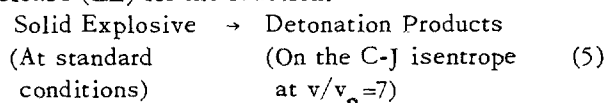

was used and results were tabulated in comparison with exptl values:

Table 4

| Explosive | Relative E Imparted to Cylinder | Ruby-Calculated Relative E Release for Expression (5) |
|-----------|---------------------------------|---|
| Comp B | 1 | 1 |
| Cyclotol | 1.09 | 1.08 |
| HMX | 1.30 | 1.28 |
| NMe | 0.56 | 0.62 |
| PETN | 1.21 | 1.20 |
| TNT | 0.74 | 0.72 |

If more detailed description of calculations is desired, see original paper of Kury et al (Ref 7)

Refs: 1) A. Solem et al, NAVORD 4006 (1955) (Description of plate push test) (Conf) (Not used) 2) Cook (1958), 29 (Pin method for determination of detonation velocity) 3) J.W. Kury et al, 3rdONRSympDeton (1960), Vol 3, p 80 (Description of flat plate test and cylinder test) (Conf) (Not used) 4) M.L. Wilkins, Univ of Calif, Lawrence Radiation Lab, Livermore, Calif, Report UCRL-7322 (1963) (Description of HEMP Code) 5) M.L. Wilkins, Ibid, UCRL-7797 (1964) (Description of sphere test) 6) M.L. Wilkins, "The Use of One- and Two-Dimensional Hydrodynamic Machine Calculations in High-Explosive Research", 4thONRSympDeton (1965), pp 519-26 7) J.M. Kury et al, "Metal Acceleration by

Chemical Explosives", Ibid, pp 3-13 8) C.G. Dunkle, private communication, July 10, 1968

Brisance-Detonation Velocity Relationship. See Vol 2 of Encycl, p B297 and Table II on p B298

Brisance Tests. See under Brisance, Correlation with Other Properties

Build-Up of Detonation. See Cooperative Build-Up of Detonation in Vol 3 of Encycl, p C512-R

Bulk Modulus and Bulk Compressibility. See Vol 2, p B323-L

Bulk (or Volume) Strength of Explosives. See Cartridge Strength in Vol 2, p C81-R

Bullet Impact Sensitivity of Explosives. See Vol 2, p B332 and the following addnl refs: *Addnl Refs:* A) Dunkle's Syllabus (1957-1958), p 120 (In a bullet gun application for perforating oil well casing RDX was initiated at low order so as to function as a propellant. The steel bullet, 1/2-inch in diam, was driven back against a 1-inch column of waxed RDX by a piece of Primacord 2 inches long. The impact of bullet against RDX initiated it at low order and the bullet was propelled at high velocity. On very rare occasions the RDX went over into high order deton. Comp C-2 may detonate entirely at low order, partially at low and change over to high order, or may deton entirely at high order depending on the nature and intensity of the shock. The entire process required from 10 to 100 microsec) B) D. Stein, "Quantitative Study of Parameters Affecting Bullet Sensitivity of Explosives", PicArnsn FREL Tech Rept **2636** (Sept 1959) C) Dunkle's Syllabus (1960-1961), p 13a (Stein found the rifle-bullet sensitivity of expls to increase with increasing thickness of confinement. For equivalent thickness, the expls were more bullet-sensitive in steel than in Al bombs. As a quantitative test of deton of the expl, measurements by means of piezoelectric shock-velocity gages showed promise. When there was no firm indication

of a shock velocity in the surrounding air higher than sonic, the expl was considered not to have detonated. In some such cases, smoke and/or flame were observed after impact)

Burning (Combustion). See "Burning" in Vol 2 of Encycl, p B343-L and "Combustion" in Vol 3, p C425-L

Burning (Combustion) and Burning Characteristics of Explosives. See Vol 2, p B343-R and the following

Addnl Ref: Anon, "Explosive Trains", **AMCP 706-179** (March 1965), pp 13-17

Burning (Combustion) and Burning Characteristics of Propellants for Artillery Weapons and Small Arms. In describing the characteristics in Vol 2 of Encycl, pp B346-L to B350-R, the following papers were not included:

- 1) A.Ya. Apin & L.G. Bolkhovitinov, "Measurement of the Rate of Burning of a Powder Under Detonation Wave Conditions", DoklAkadN **124**, 338-39 (1959) & CA **55**, 6865 (1961) [Burning rate of a French type proplnt **NB** (double-base proplnt contg NEO which is Fr designation for DEGDN), in a tablet form, d 0.60 to 0.90, were detd at pressures which may be considered being under conditions of a detonation wave. The rate of burning of NB proplnt at pressure 60000 kg/cm² varied betw 200 & 300 m/sec. Previously conducted determinations by Jacques & James Basset, CR **231**, 649-51 (1950) & CA **45**, 1769 (1951) gave rate of burning of only 0.95 m/sec at pressure of 1000 kg/cm²]
- 2) A.M. Ball, "Solid Propellants. Part I", **AMCP 706-175** (Sept 1964), pp 12-26
- 3) Anon, "Interior Ballistics of Guns", **AMCP 706-150** (Feb 1965), pp 1-8 to 1-12
- 4) V. Lindner, "Propellant Performance: The Burning Process", pp 667-78 in Kirk & Othmer's Encyclopedia, Vol 8 (1965)

Burning (Combustion) and Burning Characteristics of Propellants for Rockets. See Vol 2, pp B350-R to B355-R and the following *Addnl Ref:* Anon, "Sources of Energy", **AMCP 706-106** (Aug 1964), pp 3-23 to 3-27

Burning (Combustion) and Burning Characteristics of Pyrotechnic Compositions. See Vol 2, p B355-R to B356-R and the following Addnl Refs: 1) Anon, "Military Pyrotechnics", **TM 9-1370-200 / TO 11A10-1-1** (Sept 1966) 2) Anon, "Military Pyrotechnics Series. Part I. Theory and Application", **AMCP 706-185** (April 1967) 3) H. Ellern, "Military and Civilian Pyrotechnics", ChemPubgCo, NY (1968)

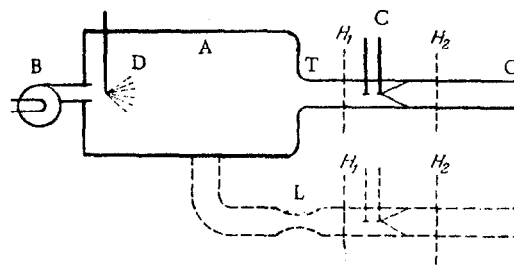

Fig A

Burning (Combustion) and Deflagration of Dusts. See under next item

Burning (Combustion) and Deflagration of Gases, Vapors and Dusts. As this subject was not discussed in previous volumes of Encycl, such as under Burning in Vol 2 of Encycl, nor under "Combustion" in Vol 3, we are including it here

Combustible (and explosive) gaseous mixtures consist of gases serving as "fuels" (such as H_2 , H_2S , CO , CS_2 , CH_4 , C_2H_2 , C_2H_4 , C_3H_6 , etc) and "oxidizers" (such as air, oxygen, or oxygen contg compds such as peroxides, nitric acid, etc). Some mixtures can burn even if they do not contain oxygen, as, for example $H_2 + Cl_2$. Volatile liquids (such as acetone, ether, alcohols and aldehydes) when mixed with oxidizers form combustible (or explosive) mixtures which may be considered gaseous. The same reasoning may be applied to mixtures of highly pulverized combustible "dusts" (such as coal, flour, starch, Al, Mg, Ti, Mn, TNT, PA, etc) with air or oxygen. The term "combustible" may be replaced by "flammable"

The ingredients of combustible (or explosive) mixts should contain fuels (gases, liquids or dusts) within certain limits of concentration, known as "lower" and "upper" combustion (and explosion) limits

For determination of concentration limits for combustion of fuel gases in air (or oxygen) burning can be conducted either in glass tubes open at one end or in apparatus illustrated in Fig of Ref 6 and Fig 28 of Ref 15, p 120, reproduced here as Fig A. For determination of lower limit, the concentration of combustible gases is decreased until flame ceases to appear, while for determination of upper limits, the concentration is increased.

In the apparatus of Fig A, a combustible mixture of known concentration, and at predetermined pressure, is located in chamber A, while air compressor B and fuel pump D, deliver simultaneously a mixture of the same compn as was originally in A, while the mixture is flowing out of the chamber thru pipe T and opening O into the atmosphere. A spark plug C, similar to those used in automobile engines, located in pipe T ignites the mixture as its front arrives at C. The resulting flame is like an inverted Bunsen flame with the vertex at the spark source C. As the mixture moves to the right, the flame is propagated in such a manner that at the cross section H_2 only the burnt products are flowing out. If the flame velocity is lower than the stream velocity, the flame is not propagated at cross section H_1 to the left against the stream. Using this method called "Stationary Combustion in a Stream", the pressure in chamber A is maintained constant in spite of the fact that mixture is flowing out of the chamber

In the lower part of the Fig A, the dotted lines show the experimental apparatus designed for combustion in "supersonic" flow. In order to make supersonic flow possible, there must be a jet constriction L between the chamber in which the gas is at rest and the pipe in which it is flowing (Ref 15, pp 120-21)

Both above methods can be used not only for detn of combustion limits, but also for detn of burning rates as will be explained further in this description

Table 1a, which is an abbreviated version of Supplement 1 in Ref 14, pp 528-31, gives

values for burning in mixtures with air of combustible gases and volatile liquids

Table 1a
Combustion Limits
(Percentage of Combustible
Gases and Liquids in Air)

| Combustible Gas or Liquid | Concentration Limits, % by Vol | |
|-------------------------------------|--------------------------------|-------|
| | Lower | Upper |
| <i>Gases</i> | | |
| Acetylene | 2.50 | 80.00 |
| Ammonia | 15.50 | 27.00 |
| Carbon Oxide | 12.50 | 74.20 |
| Cyan, C ₂ N ₂ | 6.60 | 42.60 |
| Cyclopropane | 2.40 | 10.40 |
| Ethane | 3.00 | 12.50 |
| Ethylene | 2.75 | 28.60 |
| Hydrogen | 4.00 | 44.20 |
| Hydrogen Sulfide | 4.30 | 45.50 |
| Methane | 5.00 | 15.00 |
| Propane | 2.12 | 9.35 |
| Propylene | 2.00 | 11.10 |
| <i>Liquids</i> | | |
| Acetaldehyde | 3.97 | 57.00 |
| Acetone | 2.55 | 12.80 |
| Benzene | 1.40 | 7.10 |
| Carbon Disulfide | 1.25 | 50.00 |
| Ether, Diethyl | 1.85 | 36.50 |
| Ether, Divinyl | 1.70 | 27.00 |
| Ethylol | 3.28 | 18.95 |
| Toluene | 1.27 | 6.75 |
| o-Xylene | 1.00 | 6.00 |

Table 1b, which is a copy of Supplement 2 in Ref 14, p 531, gives limits for burning of combustible gases and volatile liquids, when mixed with oxygen

Knowledge of combustion limits (and of explosion limits which is given in Table 4) of gases, volatile liquids and dusts is of great importance, especially in coal mines, where blasting is conducted with explosives. Although the lower limit for methane in air is 5%, it can be below it if some dust is present. For this reason lower limits than 5% are established by mining regulations in many countries. For example, no drilling of boreholes and no blasting is allowed in Russian coal mines unless the content of

Table 1b
Combustion Limits
(Percentage of Combustible
Gases and Liquids in Oxygen)

| Combustible Gas or Liquid | Combustion Limits, % by Vol | |
|---------------------------|-----------------------------|-------|
| | Lower | Upper |
| Ammonia | 13.50 | 79.0 |
| Carbon Oxide | 15.50 | 93.9 |
| Cyclopropane | 2.45 | 63.1 |
| Deuterium | 5.00 | 95.0 |
| Ethane | 4.10 | 50.5 |
| Ether, Diethyl | 2.10 | 82.0 |
| Ether, Divinyl | 1.85 | 85.5 |
| Ethylene | 2.90 | 79.9 |
| Hydrogen | 4.65 | 93.9 |
| Methane | 5.40 | 59.2 |
| Propylene | 2.10 | 52.8 |

methane is below 1% (Ref 14, p 131)

Besides coal mining, a knowledge of combustion (and of explosion) limits is of importance in petroleum-, metallurgical-, fuel gas, illuminating gas-industries and at the plants using volatile solvents (such as acetone, ether, alcohol, benzene, toluene, etc). Such plants include those manufg propellants (double- and triple-base) and explosives (DNB, DNT, TNT, etc). Proper ventilation of buildings, where dangerous mixts can accumulate is usually sufficient, but not always. For example, Amer Ordnance Plants working during WWII had proper ventilation, especially in buildings where TNT was either crystallized or flaked and the still warm material loaded in boxes. The atmosphere in such bldgs contained TNT dust and also some TNT vapor (which came from liquid TNT in flaking apparatus) (Vapor pressure of liquid TNT is 0.042 mm Hg at 80°C and 0.053 at 85°). It was not healthy to breathe dust and sometimes mildly exploded (or rather flashed). The TNT dust can also "flash" if it is accumulated on the hair or clothing of personnel working in such a bldg and then a cigaret is lighted (such as during lunch time outside of building). No harm was usually done, except singeing of the hair or moustache of a careless worker

No combustion (or explosion) limits of

dusts are found in the books of Baum et al (Ref 13) and of Zel'dovich & Kompaneets (Refs 6 & 15), but Andreev & Belyaev (Ref 14) give a table on p 152 in which are listed only lower limits, expressed in grams per cubic meter of air. The reasons for their not giving of upper limits are: 1) Difficulty of creating a stable mixture of high concentration of dust since part of it might precipitate and 2) Difficulty of accumulating dusts of known particle sizes. It must be noted that both lower and upper limits depend on the temperature of ignition and whether ignition is done by flame (of torch, gas burner, etc), or by an electric spark (Ref 14, p 149)

If an atmosphere contg a combustible dust above lower limit is not completely confined, it might only burn when ignited by means of a flame or an electric spark, but it will detonate if in complete (or even partial) confinement, especially if initiated by a detonator, primer, etc or when initiated by a blasting explosive such as takes place during mining operations

Following values of Table 2 for lower combustion limits of dusts in air and temperatures required for ignition are abstracted from Table 4, p 152 of Ref 14:

Table 2

| Dust in Air of: | Temperature of Ignition, °C | Lower Limit in g/m ³ of Mixture |
|-----------------|--------------------------------|--|
| Zirconium, Zr | Sometimes ignites at room temp | 40 |
| Magnesium, Mg | 520 | 20 |
| Aluminum, Al | 645 | 25 |
| Titanium, Ti | 480 | 45 |
| Rosin | 390 | 15 |
| Polyethylene | 450 | 25 |
| Coal | 610 | 35 |
| Sulfur | 190 | 35 |
| Starch | 470 | 45 |
| Soap | 430 | 45 |
| Al stearate | 400 | 15 |

Incorporation of inert gases, vapors or dusts in expl mixtures, changes their burning characteristics and if inerts are added in considerable amounts, they turn the mixts into noncombustibles. Inert additives also lower the burning rates. For

example, the rate of burning of slightly moist 2CO+O₂ mixture, which is equal to ca 90 cm/sec, drops to ca 40 cm/sec on addn of 1.8% of CCl₄ and to ca 4 cm/sec on addn of 4.5% CCl₄ (Ref 14, pp 131-32)

Andreev & Belyaev (Ref 14, pp 136-37) make a distinction between *normal burning rate* (*linear velocity*), [which is propagation of front of reaction (flame) thru stationary, unburnt portion of the gas, such as in open pipe, in the direction perpendicular to the surface of the front] and rate of burning in a closed vessel, where the unburnt gas is caused to move by pressure increasing during burning. In this case the "rate of propagation of flame" is equal to "normal burning rate" plus velocity of gas moving away from the point of initiation (Ref 2, pp 136-37)

Note: In the footnote, p 130 of Ref 14, it is stated that it is convenient sometimes to calc besides "linear velocity" the *mass velocity*, which is the quantity of material reacting during unit time per unit surface of charge's cross section

If burning is proceeding under constant pressure, such as in a Bunsen burner or in an open pipe, the rate of burning is constant. It is also practically constant if the gas, enclosed in a soap bubble, is ignited in the center by means of a small electric spark (Method of Stevens, as described in Ref 13, p 384). In this case a spherical flame front is created and as resistance of soap film is very small, the pressure and burning rates are practically constant

More common method for determination of burning rates is by using pipes closed at one end. If reaction is initiated by a small localized ignition, such as by torch or weak electric spark at an open end of the pipe, there will result slow, stationary burning with flame which will spread gradually from the ignition spot thruout the pipe. This flame consists of a thin, very hot luminous zone which separates the products of combustion from the non-reacted part of gaseous mass. Since *linear velocity* of such slow combstn is from ca 0.5 to 2 m/sec, all variations in the pressure, which are connected with heating, greatly outdistance the flame front because they are propagated with the velocity of sound, which is much

higher (ca 332 m/sec in air). The pressure created on burning becomes finally equalized with the surrounding pressure thru the open end of the pipe. In a pipe closed at both ends, the pressure increases as the flame is propagated, and the stationary conditions cease to exist. Although the pressure increases as the combustion progresses, it is, at each given instant, almost identical at the various points within the pipe (Ref 15, pp 68-9)

If, however, the reaction originates at an open end of the pipe, closed at the other end, as the result of an expln of a detonator or an expl chge, there will be a different propagation regime which is characterized by a very high velocity (2-3 thousand m/sec) in the gases accompanied by an extremely high pressure. This phenomenon is called "explosion" or "detonation". In that part of the gas which is ahead of the reaction front, there is no disturbance until the arrival of the wave, since the propagation proceeds more rapidly than sound (Ref 15, pp 68-9). This phenomenon is considered under "Detonation (and Explosion) of Gases", etc

Detonation can also arise spontaneously from combustion when a flame is propagated in very long tubes. For description of this phenomenon, Zel'dovich & Kompaneets refer to their Chapter 16, which deals with "Spin Detonation"

One of the earliest determinations of burning rates of gases was done by R.W. Bunsen (1811-1899). He allowed a combustible gas to burn while evolving from a pipe thru a narrow opening in such a manner that the flame remained close to the opening without jumping inside the pipe, and by dividing the rate of escape of gas by time he found 34 m/sec for mixts of CH₄ with oxygen and 1 m/sec for CO with oxygen (Ref 2, p 136)

A different method was proposed by a Russian scientist, V.A. Mikhel'son, as described by Andreev & Belyaev. He took photographs of flames, determined area of flame cone and the volume of gas evolving per unit time. From these data he calcd the rate of burning (Ref 14, p 136). Besides detg burning rates, Mikhel'son developed a theory of combustion in moving gases, such as in "firedamp" ("gremuchii gaz", in Rus). A

brief description of this theory, known as the "law of cosinus", is given by Baum et al (Ref 13, pp 385-87)

By the way, Mikhel'son was the physicist who, accdg to Rus sources, gave the definition and proposed the use in p,v diagram of the line known in Europe & US as *Rayleigh Line* [See Cook (1958), pp 67 & 79], but called in Russia *Liniya Mikhel'sona* [See under Detonation (and Explosion) of Gases, etc]

At the present time, burning rates are detd by "high-speed photographic methods", such as briefly described under CAMERAS in Vol 2, pp C13ff of Encycl. For example, when using a "rotating drum camera", propagation of flame in combustion of gaseous mixt in a glass pipe, closed at one end, is photographed by a film attached to a rotating drum, whose axis is parallel to the direction of propagation. The resulting photograph of flame has an upper part like a straight line inclined at an angle smaller than 90°, in relation to the base of the film. The larger the angle, the higher is the propagation velocity. This velocity is not "normal velocity of burning", but is its sum with velocity of movement of gases. Method of calcn of normal velocity is given in Ref 14, pp 137-38

If the flame is not sufficiently luminous, "visible photography" cannot be used, but the "Schlieren" and "Shadow" methods are applied (See Vol 2, pp C16 & C17)

In Table 4.2, p 139 of Ref 14 are given rates of burning of various gaseous mixts which are listed here as Table 3

Burning rates can also be detd in an apparatus described in Ref 15, pp 120-21 and reproduced here as Fig A, using "high-speed photography". The "normal velocity" in this case must be calcd by subtracting from total velocity the rate of flow of gases from chamber A due to pressure

Baum et al (Ref 13, pp 366ff) describe two theories of ignition of gases, the "thermal" and the "chain"

Thermal Theory proposed (but not actually developed) by J.H. Van't Hoff (1852-1911) was mathematically elaborated by N.N. Semenov. Accdg to this theory, the heat of reaction becomes, under certain conditions (temperature, pressure, etc), higher than losses of

Table 3
Rates of Burning of
Combustible Gases and Vapors
Mixed with Air

| Combustible Gas or Liquid | Maximum Rate, cm/sec | % Gas at Max Rate | % Gas in Stoichiometric Mixture |
|--|----------------------|-------------------|---------------------------------|
| Hydrogen | 267 | 42 | 29.5 |
| Acetylene | 131 | 10 | 7.7 |
| Ethylene | 63 | 7.0 | 6.5 |
| CS ₂ | 48.5 | 8.2 | 6.5 |
| Propylene | 43.5 | 4.8 | 4.5 |
| CO+1.2% H ₂ O | 41.5 | 53.0 | 21.5 |
| C ₆ H ₄ +0.5% H ₂ | 38.5 | 3.0 | 2.7 |
| Ethyl Ether | 37.5 | 4.5 | 3.4 |
| Methane | 37.0 | 10.5 | 9.5 |
| Cyclohexane | 35.0 | 2.5 | 2.3 |
| n-Pentane | 35.0 | 2.9 | 2.6 |
| n-Hexane | 32.0 | 2.5 | 2.2 |
| Acetone | 31.8 | 6.0 | 5.0 |

heat and this causes overheating and rapid increase in the rate of burning. There are "stationary" and "non-stationary" theories of thermal ignition and explosion of gases (Ref 13, pp 366-73). See also "Theory of Thermal Propagation of Flame" on pp 387-90) *Chain Theory*. Definition of a "chain reaction" is given in Vol 2 of Encycl, p C146-L, but we are giving here a description of application of chain theory to ignition and combustion of gases, as taken from the book of Baum et al (Ref 13)

In a chain reaction, a rapid increase in the rate of burning is caused by the accumulation of active intermediate catalytic products of reaction which create conditions favoring formation and branching of chains. These intermediate products are acting on original products, thus producing the final products. These processes require a comparatively small energy of activation (especially when active products are free radicals or atoms) and proceed with high velocity. However, initial formation of "active centers" from stable starting molecules requires great energy of activation and for this reason cannot proceed with high velocity. In order to have a reaction conducted by means of

active centers to proceed at fairly high velocity, it is necessary to deal with active centers which on contact with initial material create not only stable final products, but also new active intermediate substances. Each active product (molecule, atom, or radical), creates on disappearing during the reaction a long chain of subsequent products of reaction. Reactions in which regeneration of active intermediate products takes place are known as *chain reactions*

M. Bodenstein of Germany was the first to point out (ca 1913) that reactions can proceed by a chain of subsidiary reactions. His investigations were followed by those of C.N. Hinshelwood, N.N. Semenov et al, & others (Quoted from Ref 13, pp 373-74)

Chain theory of reaction was applied to explain the reason for the extremely high number of molecules (up to 10⁵) caused to react photochemically by only one quantum, ϵ , of light. One of such reactions is the one proceeding between chlorine and oxygen. In this case, one quantum of light causes dissociation of chlorine molecule to chemically active atoms:

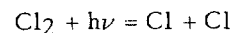

where: h = Plank's constant and

ν = atomic frequency number of radiation

In the next links of chain Cl atoms react with hydrogen molecule, creating H atom, as new active center:



then H reacts with another Cl₂, and by liberating Cl create a new active center, etc

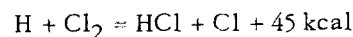

Other examples are interactions of hydrogen with oxygen and of carbon monoxide with oxygen

More detailed description of chain reactions, including mathematical treatment of process, is given in Ref 13, pp 375-81

As was already mentioned, V.A. Mikhel'son developed a theory of combustion of firedamp which was briefly described by Baum et al (Ref 13, pp 385-87)

Accdg to Andreev & Belyaev (Ref 14, pp 158ff), another theory of gaseous combustion was developed in 1938 by Ya.B. Zel'dovich & D.A. Frank-Kamenetskii. A.F. Belyaev

has shown that this theory is applicable also to combustion of volatile condensed expls. A detailed description of Z&F-K theory is given in Ref 13, pp 390-95 and its application to combustion of volatile condensed expls in Ref 14, pp 158-69

Influence of diameter of pipe on rate of burning in gases is discussed in Ref 13, pp 385-86. For example, for mixts contg 6 to 10% CH₄ in air, the highest rates are for pipes of 100 cm diam, which are equal to ca 150 cm/sec for 6% and ca 250 cm/sec for a 10% mixt. The corresponding mixts in 20 cm pipe have rates of 60 & 140 cm/sec, respectively, while in 60 cm pipe the values are 120 & 230 cm/sec. Increase of pipe diam above 100 cm does not, practically, increase the rate of burning of CH₄ in air. This diameter is called by Baum et al *critical diameter*, but it seems that it should be called *limiting* or *maximum diameter*, reserving the name "critical" for the smallest diameter at which "steady" combustion is possible. Values of "maximum" diameter for gases other than CH₄+air are either smaller or larger than 100 cm

If combustion of a gaseous mixture in a smooth pipe develops into detonation, the velocity of detonation does not depend on the pipe diameter, provided it is sufficiently large. Further discussion on the subject of detonation is given under "Detonation (and Explosion) of Gases, etc"

In all the tests described above smooth pipes or vessels have been used. Some experiments described below used rough pipes

In Ref 15, pp 188-91 are described experiments conducted in Russia by K.I. Shchelkin & V.E. Ditsent in which it was brought to light a new combustion regime, almost similar in its characteristics to the detonation regime described under "Detonation (or Explosion) of Gases, etc"

In their experiments a smooth metallic pipe ca 1 meter long was connected to a glass pipe 2 m long. The first half of glass pipe was smooth while the other half had inserted a helical wire of known diameter and of known number of turns. This arrangement is shown in Fig A taken from Ref 15, p 188. When the mixture of 50% CO + 50% air passing thru metal pipe was ignited, the flame propagated to the right

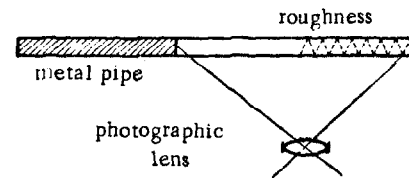

Fig A. Experimental Setup of Shchelkin & Ditsent

and when it entered the smooth section of glass pipe it was photographed by "high speed camera". Its velocity of propagation was found to be ca 2 m/sec. When the flame entered the rough section of the pipe, a considerable acceleration was observed. When the flame attained a velocity of the order of a hundred meters per second it continued to propagate with such maximum velocity. This velocity was lower and not as constant as in detonation. The maximum velocity was reproducible within 100-200 m/sec, while its mean velocity (from the source of ignition to the end of the pipe), was within 50-100 m/sec. Such a rapid flame was usually accompanied by a piercing noise and created some mechanical demolitions, such as breaking the glass pipe. Results of the work of Shchelkin & Ditsent, given on Table VI of Ref 15, p 189, are partly reproduced here in Table 4

Table 4
Comparison of
Flame Velocities in CO-Air
Mixtures in Smooth and Rough Pipes

| Mixture | d ₁ , mm | d ₂ , mm | n | U _m , m/sec | U, m/sec |
|--------------|------------------------|------------------------|------|---------------------------|-------------|
| 50%CO+50%Air | 17 | smooth | pipe | - | ca 2 |
| " " | 17 | 14.9 | 3.4 | No combstn | |
| " " | 18 | 11 | 3.5 | 790 | 188 |
| " " | 17 | 9.1 | 3.4 | 1285 | 318 |

In Table 4, d₁=inside diameter of pipe, d₂=inside diam of helix, n=number of turns of wire per cm of pipe, U_m=maximum flame velocity and U=mean flame velocity (from the ignition source to the end of the pipe)

The anomalous behavior of combustible gases in rough pipes is explained in Ref 15, pp 188-91. Its theoretical background was

worked out by Ya.B. Zel'dovich in 1944

Accdg to his theory, combustion initiated at open end of the pipe first takes place in the circumferential region of one spiral, and then the flame is propagated in the gas stream, forming a sort of an elongated cone between the reference surfaces AA' and BB' , as shown in Fig B. The process of combustion here is essentially nonuniform. The depth of the reaction zone is detd directly from kinetics (as in the case of one-dimensional propagation

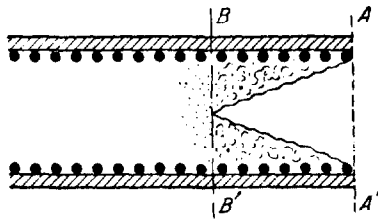

Fig B. Propagation of Flame & Reaction Zone in Rough Pipes

of detonation in a smooth pipe, such as discussed on pp 138-45 of Ref 3, and from the velocity of the reaction as it passes from the pipe surface to the interior. This velocity is identical with the combustion velocity of compressed gas. As the region of combustion is subsonic in a coordinate system moving along with the shock wave AA' , each disturbance of the gas at the turns of the wire betw AA' and BB' is shown in the motion of the shock wave as a whole. In other words, the losses due to friction at the turns of the helix, occurring over a fairly long distance AB , effectively decrease the velocity of propagation (Ref 15, p 190)

More detailed discussion on combustion in rough pipes is given on pp 190-91 of Ref 15 (See also "Detonation and Explosion of Dusts" and "Detonation and Explosion of Gases and Vapors")

Refs: 1) B. Lewis & G. von Elbe, "Combustion, Flame, and Explosion of Gases", Oxford Univ Press, London (1938) 1a) K.I. Shchelkin, DoklAkadN **23**, 636 (1939) (On the theory of detonation initiation for gaseous mixtures in pipes) 1b) K.I. Shchelkin, ZhEksper i TeoretFiz **10**, 823 (1940) (The effect of rough-

ness in the pipe on the initiation of detonation and the propagation of detonation in gases)

1c) M.A. Rivin, DoklAkadN **30**, 498 (1941)

(Effect of admixtures on the detonation of

explosive methane) 1d) A.A. Grib, Priklad-

naya Matematika i Mekhanika **8**, 273 (1944)

(Influence of the initiation point on the parameters of an atmospheric shock wave upon detonation of explosive gas mixtures)

2) W. Jost, "Explosion and Combustion Processes in Gases", McGraw-Hill, NY (1946)

(Rus translation in 1953) 2a) Ya.B. Zel'

dovich & V.V. Voyevodskii, "Kurs Teorii

Goreniya, Detonatsii i Vzryva" (A Course in the Theory of Combustion, Detonation,

and Explosion)

Kniga I. "Teplovoi Vzryv i Rasprostraneniye

Plameni v Gazakh" (Thermal Explosion and

Propagation of Flames in Gases)

Kniga II. Ya.B. Zel'dovich & D.A. Frank-

Kamenetskii, "Turbulentnoye i Geterogennoye

Goreniye" (Turbulent and Heterogeneous Combustion), IzdatMekhanInst, Moscow (1947)

3) Ya.B. Zel'dovich, "Teoriya Goreniya i De-

tonatsii v Gazakh", IzdatAkadNauk, Moscow

(1947), translated as "Theory of Combustion

and Detonation in Gases", BrownUniversity,

Providence, RI, May 1949, Wright Patterson

AFB, Dayton, Ohio 3a) Ya.B. Zel'dovich

& I.Ya. Shlyapintokh, DoklAkadN **65**, 871

(1949) (Ignition of expl gaseous mixts in

shock waves) 3b) V.E. Ditsent & K.I.

Shchelkin, ZhFizKhim **19**, 21 (1949) (Rapid

combustion of gases in rough pipes)

3c) H.F. Coward, "Explosions in Gaseous

Mixtures" in Kirk & Othmer **5** (1950) (Not

found in the later edition), pp 961-66 (Limits

of flammability of gases); 966-72 (Ignition

temperatures); 972-83 (Ignition by hot sur-

faces, friction, electric sparks, flames and

compression waves); 983-91 (Propagation of

flame deflagration) 3d) B. Lewis & G. von

Elbe, "Combustion, Flame and Explosion of

Gases", Academic Press (1951) (See also

Refs 1 & 18) 3e) D.F. Panghurn et al,

"An Extension of the Chapman-Jouguet Gas-

dynamics of Combustion", Rensselaer Poly-

technic Institute Tech Rept **AE-5402** [ONR

Contract Nonr 591 (04) NRRNo094-264], Feb 1954

3f) H. Selle & J. Zehr, Staub **1954**, 583-60

& Chim&Ind(Paris) **74**, 96 (1955) (An opinion

- on expl values of the lower limit of flammability of dust-air mixtures on the basis of thermochemical calculations) 4) H.M. Cassel et al, "Mechanism of Flame Propagation in Dust Clouds", USBurMinesProgressRept **No 7**, July 1-Sept 30, 1955, Pittsburgh, Pa. ORD R&D Project TB 2-0001 5) D.B. Spalding, "Some Fundamentals of Combustion", Butterworths, London (1955) 6) Ya.B. Zel'dovich & A.S. Kompaneets, "Teoriya Detonatsii," (Theory of Detonation), Gostekhizdat, Moscow (1955) (Engl transl see Ref 15) 7) J. Diederichsen & H.G. Wolfhard, TrFaradSoc **52**, 1102-09 (1956) (Burning velocity of methane flames at high pressures) 7a) P.L. Chambre, JChemPhys **25**, 417-21 (Sept 1956) (Ignition of a moving combustible gas stream) 7b) W.H. Geck Explosivst **1956**, 113 (Ignitable industrial dusts) 8) K.K. Andreev, "Termicheskoye Razlozheniye i Goreniye Vzryvchatykh Veshchestv", (Thermal Decomposition and Burning of Explosives), Gosenergoizdat, Moscow (1957) 9) L.N. Khitrin, "Fizika Goreniya i Vzryva" (Physics of Burning and Explosion), IzdMGU (1957) 9a) L.E. Line et al, "An Apparatus for Studying the Burning of Dust Clouds", 6thSympCombstn (1957), pp 779-86 (11 refs) 10) Dunkle's Syllabus (1957-1958), pp 99-102 (The Rayleigh-Mikhel'son and Fanno lines); 108-10 (Flame stabilization and flameholders); 115-19 (Laminar & turbulent burning); 126-27 (Coalescence of shock and combustion wave); 127 (Hugoniot equation and Chapman-Jouguet condition); 133-34 (Combustion knock) 11) H.M. Cassel, "Mechanism of Flame Propagation in Dust Clouds", USBurMines Progress Rept **No 20**, Oct 1-Dec 31 (1958), Pittsburgh, Pa 12) V.N. Kondrat'yev, "Kinetika Khimicheskikh Gasovykh Reaktsii" (Kinetics of Chemical Gaseous Reactions), IzdAkadNauk, Moscow (1958) 13) Baum, Stanyukovich & Shekhter (1959), 363-66 (Special features of burning of explosive gases); 365-81 (Theories of thermal and chain ignition of gases); 381-83 (Lower & upper limits of concentration limits of combustible gases, and vapors of volatile liquids in mixtures with air); 383-87 (Rates of burning of mixtures with air of CO, CH₄ & C₄H₁₀ and rate of flame spreading in CO-air mixts); 387-90 (Theory of thermal flame spreading); 390-95 (Theory of burning of Zel'dovich & Frank-Kamenetskii); 417-28 (Transition of combustion to detonation in gases) 13a) G.D. Salamendra et al, "Formation of Detonation Wave During Combustion of Gas in Combustion Tube", 7thSympCombstn (1959), pp 851-55 13b) T.V. Bazhenova & R.I. Soloukhine, "Gas Ignition Behind the Shock Wave", Ibid, pp 866-80 13c) H.M. Cassel & I. Liebman, USBurMines Progress Rept **No 22** (1959) (Flame propagation mechanism in dust clouds); Project DA-599-01-004 14) Andreev & Belyaev (1960), 131-36 (Burning of gases which includes lower and upper concentration limits of H₂, CH₄, C₂H₆, C₃H₈ and C₄H₁₀ in air); 136-38 (Methods for determination of rates of burning); 138-41 (Burning rates of various mixtures in air and factors influencing rates of burning); 148-53 (Burning and explosion of dust-air mixtures); 528-31 (Tables giving combustion limits of gases and liquids in mixtures with air) 15) Zel'dovich & Kompaneets (1960), 109-120 (Combustion with induced ignition velocity); 120-32 (Stationary combustion in a stream); (pages of other subjects are indicated in the text); 188-91 (Anomalous behavior of gases in rough pipes) 16) A.S. Sokolik, "Samovosplamneniye, Plama i Detonatsiya v Gazakh", IzdatAkadNauk, Moscow (1960) (Engl transl, see Ref 19) 17) Dunkle's Syllabus (1960-1961), p 9 (Addnl info on Rayleigh-Mikhel'son and Fanno lines); 9a (Slow combustion process in gases); 9b & 9c (Addnl info on flames); 9d (Typical flame stability diagram); (It is supplement to Ref 10) 18) B. Lewis & G. von Elbe, "Combustion, Flames and Explosions", Academic Press (1961) (First edition given as Ref 1) 18a) A.P. Baskakov, TrudyUral'skPolitekhnInst **1961** (108), 5-12 (Investigation of the ignition process of anthracite dusts) 19) A.S. Sokolik, "Self-Ignition, Flame and Detonation in Gases", Transl from Rus (See Ref 16), Jerusalem (1963), 463 pages 19a) V.N. Kazakov & V.I. Smirnov, IzvVysshikhUchebnZavedeniiTsvetnMet **6**(5), 50-63 (1963); CA **60**, 3941 (1964) (Conditions of self-ignition of dusts formed in lead-smelting plants) 20) H.M. Cassel, "Some Fundamental Aspects of Gas Flames", USBurMines Report of Investigation **RI 6551** (1964) 21) Yu.M. Gorokhov, PoroshkovayaMetAkadNaukUkrSSR **4**(1), 105-10 (1964) (Combustibility and expln

hazard of powder and dust from iron and its compounds)

Burning (Combustion) to Deflagration or Detonation Transition. See under "Detonation (and Explosion), Development (Transition) from Burning (Combustion) or from Deflagration"

Burning (Combustion) Erosive in Propellants is briefly discussed in Vol 2 of Encycl, p B357 [There is an error on p B357-R, 4th line from the top. It should be proplnts, instead of explns,]

Following are some additional references on erosive burning of proplnts:

Addnl Refs: A) E.W. Price, *Jet Propulsion* **25**, 61 (1955) (Algebraic solution to the problem of erosion) B) P.J. Blatz, "A Simplified Approach to Erosive Burning", 8th Symp Combstn (1962), pp 745-53 C) H. Tsuji & N. Hayashi, *Tokyo Daigaku Koku Kenkyusho Shuho* **3**, 241-59 (1963) & *CA* **59**, 6189 (1963) (Erosive burning of solid proplnts is considered by the boundary layer approximation in the aerothermochemical point of view. The numerical calcn shows that the burning rate becomes larger with increase of the velocity gradient of hot gas stream on the surface of the proplnt)

Burning, Initiation of, by Shock Waves. See T.P. Liddiard, Jr, "The Initiation of Burning in High Explosives by Shock Waves", 4th ONR-Symp Deton (1965), 487-95

Burning Instability in Gases. See K.I. Shchelkin, *Usp Fiz Nauk* **87**(2), 273-302 (1965)

Burning (Combustion) Instability in Propellants. See "Burning, Unstable (in Rocket Motors)" in Vol 2 of Encycl, pp B361 & B362 and the following

Addnl Refs: A) L. Crocco & S.I. Cheng, "Theory of Combustion Instability in Liquid Propellants", AGARD Monograph No 8, Butterworths, London (1956) B) J.E. Crump & E.W. Price, "Catastrophic Changes in Burning Rates of Solid Propellants During Combustion Instability", *ARS J* **30**, 707 (1960) C) R. Denison & E. Baum, "A Simplified Model for Unstable Burning in Solid Propellants", *ARS* **31**, 112 (1961) D) F.H. Reardon, "An

Investigation of Transverse Mode Combustion in Liquid Propellant Rocket Motors" (PhD Thesis), Princeton Univ, June 1, 1961 E) L.A. Dickinson, "Command Initiation of Finite Wave Axial Combustion Instability in Solid Propellant Rocket Motors", *ARS* **32**, 643 (1962) F) S.Z. Burstein & V.D. Agosta, "Combustion Instability: Non-Linear Analysis of Wave Propagation in a Liquid Propellant Rocket Motor", Polytechnic Institute of Brooklyn, Dept of Mechanical Engineering, March 1962 G) F.L. Schuyler, "Analytical Investigations of Combustion Instability in Solid Propellant Rockets", Illinois Inst Technol- Rept **II TRI-A6002**, Chicago, Ill (1963) H) W.A. Sirignano & L. Crocco, "A Shock Wave Model of Unstable Rocket Combustors", *AIAA* **2**, 1285 (1964) I) B.T. Zinn, "A Theoretical Study of Nonlinear Transverse Combustion Instability in Liquid Propellant Rocket Motors" (PhD Thesis) Princeton Univ, May 1966 J) C.E. Mitchell, "Axial Mode Shock Wave Combustion Instability in Liquid Propellant Rocket Engines" (PhD Thesis), Princeton Univ, **NASA CR 72229** (1967) K) E.L. Capener et al, "Driving Processes of Finite-Amplitude Axial-Mode Instability in Solid Propellant Rockets", *AIAA*, **5**, p 938 (May 1967) L) H. Krier et al, "Nonsteady Burning Phenomena of Solid Propellants: Theory and Experiments" *AIAA* **6**, 278 (1968) M) L. Crocco, "Research on Combustion Instability in Liquid Propellant Rockets", 12th Symp Combstn, Poitiers, France, July 14-20, 1968 (published in 1969), pp 85-99 N) E.W. Price, "Recent Advances in Solid Propellant Combustion Instability", *Ibid*, pp 101-113 O) G.A. Marxman & C.E. Woolbridge, "Finite-Amplitude Axial Instability in Solid-Rocket Combustion", *Ibid*, pp 115-27 P) W.A. Sirignano, "A Theory of Axial-Mode Shock-Wave Oscillations in a Solid-Rocket Combustor", *Ibid*, pp 129-37 Q) B.T. Zinn & C.T. Savell, "A Theoretical Study of Three-Dimensional Combustion Instability in Liquid-Propellant Rocket Engines", *Ibid*, pp 139-47 R) R.J. Priem & E.J. Rice, "Combustion Instability with Finite Mach Number Flow and Acoustic Liners", *Ibid*, pp 149-59 S) M.W. Thring, "Combustion Oscillations in Industrial Combustion Chambers", *Ibid*, pp 163-68

T) M. Barrère & F.A. Williams, "Comparison of Combustion Instabilities Found in Various Types of Combustion Chambers", *Ibid*, pp 169-81 U) M.W. Beckstead et al, "Combustion Instability of Solid Propellants", *Ibid*, pp 203-11

Burning, Laminar, of Gases. Influence of pressure and temperature on the laminar burning velocity of stoichiometric acetylene-air mixtures using a constant-volume bomb method is described by M.L. Agrawal & S.P. Sharma in *UnivRoorkeeResJ(India)*, **8**(3-4), Part 11, 81-102(1965) (in Engl)

Burning, Neutral. See Vol 2 of *Encycl*, p B358-L

Burning, Propagative. Under the term "propagative burning" may be included the self-sustained, steady-state, incandescent reaction between a fuel and an oxidant, once it is initiated to its ignition temp

Investigators of works listed here as Refs 1, 2 & 3 have been concerned mostly with rates of propagative burning in gaseous mixtures and also for some solid-state systems in which neither fusion nor crystalline transitions were considered. Jackson (Ref 4) investigated the burning of quaternary compositions

Freeman & Weingarten (Ref 5) investigated burning of pressed, unconfined columns of uniform, finely-divided mixtures of a fuel (such as Mg powder) and an oxidant (such as the alkali nitrates), which are capable (once ignited) of steady-state burning in which the reaction front progresses propagatively to the other end of the column at a constant linear velocity, dz/dt . During propagative burning the ingredients undergo crystalline transition, fusion and vaporization. The kinetics and thermodynamics of chemical and physical changes were considered, as well as thermal properties and particle size. The effects of radiation and heat transfer by diffusion of material or gases were neglected. The burning column was taken sufficiently thick so that heat losses from the side were unimportant with respect to the position of the reaction front

The relationships derived by F&W appear to be substantiated by previously reported data on the effects of particle size and relative amounts of ingredients for the binary systems: Mg-LiNO₃, Mg-NaNO₃, & Mg-KNO₃; the quaternary systems: Mg-NaNO₃-Laminac-PVC; and the 5 components systems of Mg-Ba(NO₃)₂-KClO₄-Laminac-PVC

The change in rates of burning as a function of particle size may be calcd from the derived equations. The method used to calculate the percentage of metal powder fuel, giving the maximum burning rate is discussed, as well as other factors required for the theoretical evaluation of the data

See also Ref 6 for further discussion of this subject

Refs: 1) J.E. Spice & L.A.K. Stavelly, *JSCI* **68**, 348(1949) 2) F. Booth, *Trans-FaradaySoc* **49**, 272(1953) 3) R.D. Schultz & A.O. Decker, *5thSympCombstn*(1955), p 260 4) B. Jackson, *PicArnsTechNote PL-C-14* (April 1958) 5) E.S. Freeman & G. Weingarten, "A Thermal Theory for Rates of Propagative Burning", *PicArns FREL Tech Rept 2596* (June 1959). Ordnance Project TS5-5407; Dept of the Army Proj 504-01-027 6) Anon, "Military Pyrotechnic Series. Part 1. Theory and Application", *AMCP 706-185* (April 1967), pp 3-27 to 3-32

Burning Rate and Burning Rate Coefficient. See Vol 2, p B358

Burning Rates of Condensed Explosives.

Burning rates of expls are briefly discussed in Vol 2, pp B343-R to B344-L together with some other burning characteristics. Several values for rates are given in Refs listed on p B344 to B346. For example, Ref 10, p B344-R gives rate of burning of primary expls, such as MF compressed as pellets at 1750 kg/cm², 1.5-2.0 cm/sec at atm pressure, vs 0.05-0.1 cm/sec for secondary expls, such as TNT, PETN, PA, etc. In Ref 13, p B345-L are given: 1.55 cm/sec for MF at ρ (density) 3.80 g/cc; 0.95 for Tricycloacetate Peroxide at ρ 1.2; 0.65 for TATNB at 1.75; 2.15 for DADNPh at 1.45; and 1.50 for K Picrate at ρ 1.83. Lead Styphnate exploded on ignition (instead of burning), but its mixture

with 60% talcum burned with a rate of 14.5 cm/sec (See also Addnl Refs in Vol 2, pp B353-R to B355-R)

In the book of Andreev & Belyaev (Ref 1), which was not listed as a ref in Vol 2, p B345, reported on p 172, that Svetlov & Fogel'zang found that pellets of LSt can burn (instead of exploding) if they are very strongly compressed and its rate is ca 25 cm/sec in atms of 15 mm Hg to 150 kg/cm² and goes to 33-34 cm/sec in atms above 150 kg/cm². Rates of burning of NGc (Nitroglycol) in liquid form as taken from Fig 4.31, p 183 are as follows (approximately): 0.2 cm/sec at pressure of 5 kg/cm²; 0.3 at 10; 0.5 at 15; 1.5 at 20; 4.5 at 30 and 6 cm/sec at 35 kg/cm². Rates of burning of gelatinized NGc are given on p 157 as follows: 0.2 cm/sec at 10 kg/cm²; 0.75 at 30; 1.1 at 50; 2 at 100; and 3.5 cm/sec at 150 kg/cm². Fig 4.26, p 172 gives rates of burning of MF as follows: 2.0 cm/sec at atm pressure; 5.5 at 20 kg/cm²; 7 at 40; 8 at 60; 11 at 100; and 12.5 cm/sec at 140 kg/cm². The same Fig gives the following rates for K Picrate: 1.8 cm/sec at atm press; 4 at 5 kg/cm²; 5.9 at 20 and 6 at 40 to 80 kg/cm²

Burning rates of HE's such as PETN, RDX and HMX are reported by Taylor (Ref 2)
Refs: 1) Andreev & Belyaev (1960), pp 157, 172 & 183 2) J.W. Taylor, pp 77-87 in 3rdONRSympDeton (1960)

Burning Rates of Explosive Mixtures with Air or Gases, Vapors and Dusts. As this subject was not discussed in Vol 2 under "Burning" or in Vol 3 under "Combustion", we are describing it here briefly

Baum et al (Ref 1, pp 384-85) give max rate for mixts with air: CO - 110 cm/sec, CH₄ - 620 cm/sec and C₄H₁₀ - 480 cm/sec. These values are much higher than those listed by Andreev & Belyaev (Ref 2, p 139), who give for CO-air with 1.2% H₂O - 41.5, and for CH₄-air - 37.0 cm/sec; no value for C₄H₁₀ is given. Following are values for other stoichiometric mixts with air: H₂ - 267 cm/sec, C₂H₂ - 131, C₂H₄ - 63, CS₂ - 48.5, C₃H₆ - 43.5, C₆H₆ (contg 0.5% H₂) - 38.5, ether - 37.5, cyclohexane - 35.0, C₅H₁₂ - 35.0, C₆H₁₄ - 32.0, and acetone - 31.8 cm/sec

Mixtures of fine combustible dusts with air in certain proportions can be ignited and they either burn or explode with velocities of propagation lower than those for explosive gases. Andreev & Belyaev (Ref 2, pp 148-53) treat briefly this subject, but do not give any rates of burning. More information on expln of dusts is given under Detonation and Explosion of Dusts, Mists and Vapors
Refs: 1) Baum, Stanyukovich & Shekhter (1959), 384-85 2) Andreev & Belyaev (1960), 139-40 & 148-53

Burning Rates of Propellants for Artillery Weapons.

A brief discussion is given in Vol 2, pp B346 to B350 together with description of other burning characteristics. A value of 0.5082 in/sec (1.29 cm/sec) at 1000 psi (70.31 kg) for proplnt contg NC (13.25% N) 54.0, NG 43.0 & DEtDPhUrea 3% is given on p B350-L (See also Addnl Refs on pp B353-R to B355-R)

Burning rate characteristic, B, of equation $r=BP^n$ and pressure exponent, n, are given in Vol 2, p 34, Table V for US cannon proplnts M1, M2, M6, M15, M17, M30 & M31

Andreev & Belyaev (Ref 1) give the following values for burning rates of some Russian propellants: 0.1 cm/sec at atm pressure to 0.3 at 4 kg/cm² pressure for a single-base proplnt similar to US "Pyro" proplnt (p 178); for a double-base NG proplnt - 0.3 cm/sec at atm press, 1.9 at 100 kg/cm², 3.0 at 200, 4.2 at 300 and 5.0 cm/sec at 350 kg/cm² (p 157); for a composite proplnt (compn not given): 0.17 cm/sec at atm press, 0.2 at 7 kg/cm², 0.3 at 14, 0.5 at 50, and 0.7 cm/sec at 70 kg/cm² (p 192)

Lindner (Ref 2) gives for cast double-base proplnt contg NC (12.6% N) 58.6, NG 24.2, DMePh 9.6, DNT 6.6 & EtCentr 1.0% (with 0.1% C black added) burning rate 0.27 in/sec (0.69 cm/sec) at 1000 psi (70.31 kg/cm²) and 20° C (p 708); for cast, high-energy double-base proplnt contg NC (12.6% N) 25, NG 30, Amm Perchlorate 20, Al 20 & plasticizer 5%, with 1% stabilizer added the rate is 0.7 in/sec (1.78 cm/sec) at 1000 psi (70.31 kg/cm²) and 20° C (p 709); for cast composite proplnt contg Amm Perchlorate 21, K Perchlorate 47,

rubber-base binder 29 & curing agents 3%, the rate is the same as for previous proplnt (p712); for cast (or extruded), high-energy, composite proplnt contg Amm Perchlorate 60, fuel binder 25, Al 14 & additives, (which include catalysts such as Fe oxides and curing agents such di-epoxides) 1%, the rate is 0.30 in/sec (0.76 cm/sec) at 1000 psi & 20° (p 713)

Refs: 1) Andreov & Belyaev (1960), 157, 178 & 192 2) V. Lindner, "Propellants" in Kirk & Othmer, Vol 8(1965), 708, 709, 712 & 713

Burning Rates of Propellants for Rockets. A brief discussion is given, together with other burning characteristics, in Vol 2 of Encycl, pp B350-R to B353-R. For example, on p B352-L are given the following linear burning rates of US proplnts JP & JPN and of Russian Cordite at various temperatures. At pressure 1000 psi and 70°F (21.1°C), the rate for JP is 0.671 in/sec (1.704 cm/sec), for JPN 0.651 in/sec (1.6 cm/sec) and for Russian Cordite, contg NC (12.2% N) 56.5, NG 28.0, DNT 11.0 & EtCentr 4.5%, with added 0.08% of candelilla wax 0.290 in/sec (0.736 cm/sec). Judging by these values, the Amer proplnts may be considered as "fast-burning", while Rus proplnt is "slow-burning"

Lindner (Ref 1) gives for M7, double-base solvent extruded rocket propellant contg NC (13.15% N) 54.6, NG 35.5, EtCentr 0.9, K Perchlorate 7.8 & carbon 1.2% 0.70 in/sec (1.78 cm/sec) at 1000 psi (70.31 kg/cm²) and temp 20° (p 704); for double-base solventless extruded rocket propellant JPN, contg NC (13.25% N) 51.40, NG 42.90, DEtPh 3.23, EtCentr 1.00, K sulfate 1.25, C black 0.20 & candelilla wax 0.02% 0.60 in/sec (1.52 cm/sec) at 1000 psi & 21° (p 706)

Refs: 1) V. Lindner, "Propellants" in Kirk & Othmer's Encyclopedia, Vol 8(1965), pp 704 & 706

Burning Rates of Propellants; Experimental Techniques. Burning rates of gun propellants are usually determined in *closed bombs* (vessels), while for rocket proplnts the *strand burning apparatus* is used. Both methods are described in Vol 3 of Encycl, under "Closed Bomb", pp C330 to C335, Figs on pp C333

& C335, and by V. Lindner in Kirk & Othmer's Encyclopedia, Vol 8(1965), pp 715-18 (Figs 7.1 & 7.2)

Burning Rates of Pyrotechnic Compositions.

Burning rates of pyrotechnic compns are briefly discussed in Vol 2 of Encycl, pp B355-R to B356-R together with some other burning characteristics. On p B355-R are given burning rates ranging, at atm pressure, between 0.1 mm/sec and 2.5 mm/sec for binary stoichiometric mixts of fuels and oxidizers. There are also given the values for illuminating mixts 1-10 mm/sec, tracing mixts 2-10, signal lights 1-3, incendiary (thermites) 1-3 and smoke mixts 0.5-2 mm/sec. These values are listed in the book of Shidlovsky (Ref 1, pp 110-11)

In the book of Ellern (Ref 2) are listed burning rates for Fuse Trains (p 208), mixts of Mg & oxidizers and other mixts in various places. Ref 4 more conveniently tabulates burning rates of Gasless Delay Compns (p 5-35), mixts of various oxidants with Mg (p 6-43), pyrotechnics with various polyester resin binders (p 6-47), yellow signals (p 6-51), and other pyrotechnics

Refs: 1) A. Shidlovskii, "Osnovy Pirotekniki", GosIzdOboronProm, Moscow (1954), 110-11 2) H. Ellern, "Modern Pyrotechnics", Chem-PublgCo, NY (1961), pp 143ff and 2nd edition (1968) 3) Anon, "Military Pyrotechnics", **TM 9-1370-200** (1966) (Does not give burning rates of pyrotechnic compns, but lists on Table 1 of Appendix "burning times of various pyrotechnic items, such as flares, illumination signals, tracers, smoke signals, simulators, fusee warning RR and starter fire") 4) Anon, "Military Pyrotechnics Series. Part 1. Theory and Application", **AMCP 706-185** (April 1967)

Burning Time of a Rocket (or a Jato). See Vol 2 of Encycl, p B360-R

Burning Train or Igniter Train. See Vol 2, p B360-R

Burst. See Vol 2, p B363-R

Bursting Charge Explosive Train. Same as Explosive Train or High-Explosive Train

Burst Pressure. See Vol 2, p B365-L

Burst Range. See Vol 2, p B365-L

Burst Wave. See Vol 2, p B365-L

C

Calorific Constants of Explosives and Propellants.

See Vol 2, p C8-R

Calorific Values of Explosives and Propellants.

See Vol 2, pp C9 to C10 incl and also the following:

Addnl Refs: A) N.T. Volsk, "Calorific Values of Smokeless Powders as Affected by Variation in Composition, Granulation, etc", PATR 602(1935) B) C.G. Dunkle, "Calorific Values of Smokeless Powders as Affected by Variations in Composition, Granulation, etc", PATR 620(1935) C) W.H. Rinckenbach, "Calorific Values of Smokeless Powders as Affected by Variations in Composition, Granulation, etc", PATR 673(1935)

Calorimeter and Calorimetry. See below under "Calorimetric Measurements in Combustion, Deflagration, Explosion and Detonation"

Calorimetric Bomb of Bichel (Bichel Pressure Gage). See Bichel Calorimetric Bomb in Vol 2 of Encycl, p B111-R

Calorimetric Measurements in Combustion, Deflagration, Explosion, and Detonation.

See "Calorimeter, Calorimetry and Calorimetric Determinations", in Vol 2 of Encycl, pp C10 - C12 and the following:

Addnl Refs: A) J. Taylor & C.L.R. Hall, PhysChem 51, 593(1947) (Calorimetric bomb used by Research Dept at Ardeer, Scotland) B) R.L. McKisson & L.A. Bromley, "A New High-Temperature Calorimeter", USAEC (US Atomic Energy Commission) Report UCRL 688 (1950) (A calorimeter for use in the temp interval 600 to 1500°K contg a thermostat of molten tin surrounding a cavity in which the sample is placed. The calorimeter is resistance-heated, and control of the thermostat temp to $\pm 0.5^\circ\text{C}$ is effected by means of a modified "single-speed floating control". The internal parts are surrounded by a layer

of powdered graphite insulation which is contd in a water-cooled cell. The principle of opn is the actual measurement of only a small fraction of the desired heat of reaction, and conversion to the desired value by use of heat capacity data of high accuracy. This is effected by adding cold samples to a hot melt so that a large fraction of the liberated heat is used in heating up the samples) C) H.W. Sexton, "The Calorimetry of High Explosives", ARDE (Armament Research and Development Establishment) (Changed to ARE) Report (S) 4/56, April 1958 (Conf) D) C.G. Dunkle, Syllabus at PicArnsn, Session 23, pp 277-78, 19 March 1958 (A colorimeter developed at Woolwich Arsenal, England, ca 1940 for detn of heat of expln used charges up to 5 g. It was realized, however, that such small chges do not give reliable results because they are influenced by the method of initiation. Accordingly at Woolwich and the USBurMines, Pittsburgh Station, larger calorimeters were developed capable of taking charges up to 250 g. However, as the BurMines calorimeter used no confinement for the expl chge it did not give the values encountered on deton of bombs, shells etc. Then it was decided at PicArnsn that sufficient and accurate info could be obtd only with samples as large as 50 g of expl under adequate confinement; hence a suitable bomb and jacket were built capable of withstanding the deton of a confined 50 g HE chge. There were several factors to be considered from a practical view-point in designing this equipment. The walls of the bomb had to withstand very high shock pressures and the impact of high-velocity steel fragments which could be moving as fast as a mile per second. Sealing was a difficult problem. Yet the bomb had to be of moderate size so as to have a reasonable thermal capacity in view of the large amt of heat evolved. For example, the deton of 50 g of Tetryl should give a temp rise from 1 to 3° C in the calorimeter. The PicArnsn bomb has a number of features incorporated that permit automatic operation as an adiabatic calorimeter and, if found to not be sufficiently accurate when used in this manner, it can still be operated as an isothermal

calorimeter. For the adiabatic operation, a special recorder was designed which automatically controls the temp of the jacket so as to follow the bath temp while it rises after the detonation. For the temperature-sensing element a choice is made of a thermocouple, resistance thermometer, or thermistors. The system for remote control opn was later installed

The British scientists reported in 1956 a series of heats of deton of typical HE's, but the values obtd by them are classified, as usual

Wherever values of heats of detonation, combustion and formation are available in open literature or unclassified reports, they are included in our Encycl under individual expls

Note: Accdg to C.G. Dunkle, the decision to use at PicArns larger samples, such as 50 g was made because some earlier tests using small samples gave unreliable results
 E) Andreev & Belyaev (1960), 423 (Calorimeter of Apin & Belyaev and other calorimeters used in Russia for determination of heats of explosion) F) J.R. Welty & C.E. Wicks, "Ice Calorimeter for the Precise Measurement of Heat Content from 0° to 1500° K", USBurMines Report of Investigation **RI 6028** (1962) G) E.S.J. Tomeszkó & J.G. Aston, "Calorimetry" in Kirk & Othmer 2nd editn, Vol 4 (1964), pp 35-53 H) D.L. Ornellas et al, "A Detonation Calorimeter and the Heat of Products of Detonation of Pentaerythritol Tetranitrate (PETN)", 4th-ONRSympDeton (1965), p 167 (Abstract); and RevSciInstrs **37**, 906 (1966) [See also under DETONATION (AND EXPLOSION), DEFLAGRATION (AND COMBUSTION), HEATS OF]

Calorimetric Potential, Apparent (Potential calorimétrique apparent, in French). See Vol 2 of Encycl, p C9-R

Cameras, High Speed Photographic for Investigating Detonation Phenomena. See "CAMERAS" in Vol 2 of Encycl, pp C13-L to C19-R and the following:

Addnl Refs: A) W. Struth, "High-Speed Photo-

graphy of Hypervelocity Shots in Reacting Gases", ProcInternCongrHighSpeedPhot, 6th, Scheveningen, Netherland, 1962, pp 443-49 (Pub 1963) (in German) B) T.P. Liddiard, Jr et al, "Application of the High-Speed Focal-Plane Shutter Camera to Explosives Research", Ibid, pp 497-503 (in English) C) M. Kusakabe & Y. Mizushima, "Study of Explosion by Schlieren Photography", Ibid, pp 504-07 (in English); CA **60**, 14325 (1964)

Card-Gap Test for Determination of Sympathetic Detonation. See under Detonation by Influence and also Refs 40, 47, 48, 54 & 58 under Detonation, Experimental Procedures

Cartridge (or Charge) Diameter - Detonation Velocity Relationship. See under Detonation Velocity

Cartridge Strength. See Vol 2, p C81-R

Cased Charges or Cased Explosives. See Vol 2, p C82-R and L.H. Thomas, "Theory of the Explosion of Cased Charges of Simple Shape", BRL Report **475** (1944)

Cathode-Ray Tube and Cathode-Ray Oscillograph. See Vol 2, p C91-R

Cavitation in Explosive or Propellant Charges. See Vol 2, p C92-L

Cavitation Phenomenon. Studies of deton of liquid expls, such as 50/50 - NG/EGDN, by means of high-speed photographic cameras (See Vol 2, pp C13ff), conducted by Gibson et al (Ref 3, pp 1-2 & 12-13), indicated that the initiation stimulus given to such expls in the *card-gap test* (qv) is a complicated phenomenon. The usual concept of the material being subjected to a "pure shock" is inadequate. Rather, the sample is subjected to a wide range of interacting forces and consideration of these interactions lead Gibson et al (Ref 3) to suggest a new mechanism for the initiation of deton in liq expls. The mechanism is essentially one of *cavitation* created by shock interaction, possibly with additional heating of the liquid

provided by shear forces resulting from differential particle velocities in the liquid, and betw the liquid and the container walls. A contribution to heating may result from compression of the liquid. If a liquid body is exposed to intense vibration, the bubbles (cavities or pockets) are likely to be formed from the dissolved gases. Such cavities may first be very small but eventually they grow in size by coalescing the small bubbles and, if the liq expl is volatile (such as NG), some vapors will accumulate in the voids. Bowden et al postulated that the adiabatic heating of such cavities would be a source of local reaction, and developed a theory of initiation, briefly described in Vol 2 of this Encycl, p B320-L, under "Bubbles of Gas in Explosives". Selberg (Ref 1) and Bolkhovitinov (Ref 2) disagreed with Bowden's theory, based on consideration of thermal relaxation times for very small bubbles (10^{-3} to 10^{-5} mm). Gibson et al (Ref 3, p 13) consider, however, that during cavitation the small bubbles may coalesce into larger bubbles of a size sufficient for compression to result in adiabatic heating. Also, any decompn of the vapor or droplets in the bubbles which results in the production of gas also causes an increase in bubble size. The time required for the foci to grow thru coalescence and reaction may well account for the long delays observed in the initiation process (Ref 3, pp 12-13)

It has been recognized that many solid propellants, which are not detonable in their manufd form, are easily detonated when interconnected voids are introduced. Thus, there is little doubt that the presence of gas-filled voids affects the detonability of composite proplnts as well as the ability of double-base proplnts to undergo transition from deflgrn to deton; however, the high-performance, double-base system is capable of supporting a deton identical to that obt'd in a pure compd explosive when initiated by an expl-generated shock wave of sufficient magnitude (Ref 3, pp 1-2)

It has been known among workers in expls industries and in mining that aged Gelatin-Dynamites are difficult to initiate, owing to the absence of gas bubbles in their structure,

usually present in freshly made gelatinous expls. The aged Gelatin-Dynamites can, however, be "rejuvenated" by prolonged rolling of the cartridges on a flat surface (See Vol 1 of Encycl, p A112-L)

See also description of "Air-Bubble Theory" (Luftblasentheorie in Ger), p A111, Vol 1 of Encycl, under Ageing (Aging) of Dynamites

Refs: 1) H.L. Selberg, *ApplSciResearch* **A5**, 450-52 (1955) 2) L.G. Bolkhovitinov, *Dokl-AkadN* **125**, 570-72 (1959) & **126**, 322-24 (1959) 3) F.C. Gibson, C.R. Summers & F.H. Scott, "Studies on Deflagration to Detonation in Propellants and Explosives", *USBurMines-SummaryRept* **3863** (1962), ARPA Order Nos 44-59 & 44-61

Cavity-, Hollow Charge-, or Shaped Charge Effect. See under DETONATION, MUNROE-NEUMANN EFFECT

Chain Explosions and Chain Reactions. See Vol 2, p C146-L and in this section under Detonation (and Explosion), Chain Reactions

Chain Reaction in Nucleonics. See Vol 2, p C146-L and Vol 1, p A501-L, under Atomic Energy

Chain Reaction Theory of the Rate of Explosion in Detonating Gas Mixtures. See B. Lewis in *JACS* **32**, 3120-27 (1930)

Chalon Apparatus for Determination of Brisance. See Vol 2, p C147-L

Chamber Pressure in Guns, Measurements of. See Vol 2, p C147-R

Chapman-Jouguet (CJ) Condition. See Detonation, Chapman-Jouguet (CJ) Condition

Chapman-Jouguet Deflagration. See Deflagration, Chapman-Jouguet

Chapman-Jouguet Detonation. See Detonation, Chapman-Jouguet

Chapman-Jouguet Hypothesis. See Detonation, Chapman-Jouguet Postulate or Hypothesis

Chapman-Jouguet Isentrope. See Detonation, Chapman-Jouguet Isentrope

Chapman-Jouguet Layer. See under Detonation, Chapman-Jouguet Point

Chapman-Jouguet Parameters. See Detonation, Chapman-Jouguet Parameters or Chapman-Jouguet Variables

Chapman-Jouguet Particle Velocity. See Detonation, Chapman-Jouguet Particle Velocity

Chapman-Jouguet Plane. See under Detonation, Chapman-Jouguet Point

Chapman-Jouguet Point. See Detonation, Chapman-Jouguet Point

Chapman-Jouguet Postulate. See Detonation, Chapman-Jouguet Postulate or Hypothesis

Chapman-Jouguet Pressure. See Detonation, Chapman-Jouguet Pressure

Chapman-Jouguet Process. It is either CJ Deflagration or CJ Detonation

Chapman-Jouguet Stability Condition. See Detonation, Chapman-Jouguet Stability Condition

Chapman-Jouguet State. See Detonation, Chapman-Jouguet State

Chapman-Jouguet Surface. See under Chapman-Jouguet Point

Chapman-Jouguet Temperature. See Detonation, Chapman-Jouguet Temperature

Chapman-Jouguet Theory. See Detonation, Chapman-Jouguet Theory

Chapman-Jouguet Variables. See Detonation, Chapman-Jouguet Variables

Chapman-Jouguet Velocity. See Detonation, Chapman-Jouguet Velocity

Chapman-Jouguet Zone. See Detonation, Chapman-Jouguet Zone

Characteristic or Characteristic Curve. It is a curve which is tangent at every point to *characteristic direction* (qv)

Characteristic Direction. Some linear combination of two equations which may permit a relation between derivatives of u and v , which are components of \vec{q} (material velocity vector) in the "coordinate direction".

A discussion on this subject is given in the paper of M.W. Evans & C.M. Ablow, "Theories of Detonation", *ChemRevs* **61**, 132 (April 1961)

Characteristic Data (Safety) for Explosive Materials. See Vol 2 of *Encycl*, p C148-R

Characteristic Product of Berthelot. See Berthelot's Characteristic Product in Vol 2, pp B105-L to B106-L

Characteristics of Explosives and Propellants. See Vol 2, p C149-L and the following *Addnl Refs:* A) W.M. Evans, *PrRoySoc* **204A**, 12-17 (1950) & *CA* **45**, 10587 (1951) (Some characteristics of detonation) B) W.H. Anderson & R.B. Parlin, "New Approaches to the Determination of the Thermodynamic-Hydrodynamic Properties of Detonation Processes", Univ of Utah, Inst for Study of Rate Processes, *TechRept XXVIII* (1953), Contract N7-onr-45107 C) W. Fickett & R.D. Cowan, "Calculation of Detonation Properties in the Detonation Processes", p 265 in the *2ndONRSympDeton* (1955) & *JChemPhys* **24**, 4 (1956) D) A. Vidart, *MP* **42**, 83-144 (1960) (9 refs) (Calc'n of detonation characteristics for condensed expls) E) J. Berger et al, *AnnPhys* [13], **5**, 1144-76 (1960) & *CA* **55**, 10890-91 (1961) (Determination of detonation characteristics of solid expls) F) H.H. Licht, *Explosivstoffe* **15**(4), 73-8 (1966); *CA* **65**, 13488 (1966) (Calculation of Detonation Characteristics by Means of a Differential Decomposition Equation) (See also Detonation Parameters and Detonation Properties)

Charge Density - Detonation Velocity Relationship. See under Detonation Velocity - Density Relationship

Charge Diameter - Detonation Velocity Relationship. See under Detonation Velocity - Diameter Relationship

Charge Length, Variation of End Effect With. See Fig 5.5 in Cook (1958), p 98

Charge Length, Variation of Wave Shape With (In Ideal and Nonideal Detonations). See Figs 5.7a and 5.7b in Cook(1958), p 101

Charge Limit. See Vol 2 of Encycl, p C151-L

Charge Parameters in Detonation (and Explosion).

For a chemical reaction to be detonative, energy release is a necessary but not a sufficient condition. Thus a thermite composition has energy adequate for support of a high-velocity detonation, yet cannot be made to detonate. Even the rapid generation of gas may not suffice to produce an explosion. For instance, a charge of Composition C-2, even though completely surrounded by ten times its weight of thermite burning at 5000° F, would be completely consumed in a few seconds without detonating, unless subjected to a shock (Ref 3, p 120). In practically every case, initiation of a detonation requires external application of a shock, or internal development of one in the burning charge

After detonation is initiated, the velocity with which the process may advance into the undetonated material depends on many charge parameters. A most important one (Ref 3, p 270) is the complex of factors which includes charge density, particle size, granulation, porosity, and homogeneity. The discussion under *Cavitational Phenomenon* (qv) concerns this complex. Other important charge parameters (Ref 3, p 205) are the chemical nature of the explosive, the degree of confinement and charge diameter, the nature of the initiation, the initial temperature of the explosive charge, and the external pressure (See also Refs 1 & 2)

Refs: 1) R.B. Parlin & D.W. Robinson, "Effect of Charge Radius on Detonation Velocity", Univ of Utah Inst for Study of Rate Processes, Contract **N7-onr-45107**, TR VII (Oct 1952) 2) M.E. Malin et al, "Particle-Size Effects in Explosives at Finite and Infinite Diameters", JApplPhys

28, 63-9(1957) 3) Dunkle's Syllabus **18** (12 Feb 1958), pp 205-16 and **23**(19 March 1958), pp 270-71

Charge Weight Ratio. See Vol 2, p C153-R

Chemical Reaction in a Detonation Wave. See under Detonation Waves

Chemistry and Physics of Explosive Phenomena. See Series of Progress Repts entitled "The Physics and Chemistry of Explosives Phenomena", compiled by USBurMines, Pittsburgh, Pennsylvania, OrdnProject **TA 3-5001**, Jan 1948 to Dec 1953

C-J. or CJ. Abbr for Chapman-Jouguet

Classical Theory of the Plane Detonation Wave. See Detonation, Classical Theory of Plane Detonation Wave

Clean (or Hydrogen) Bomb. See Vol 1, p A499-R under Atomic (Nuclear) Bomb

Closed Bomb Calorimeter. See Vol 2, p C11-L, under Calorimeter

Combustion. See Vol 3, p C425-L and also Burning in Vol 2, p B343-L and Combustion of Propellants for Rockets in this section

C.G. Dunkle (private communication 7 Nov, 1967) gives this definition: "Combustion is generally taken to mean the vigorous reaction of oxygen with some fuel"

Following are some Addnl Refs on Combustion and Burning:

A) Ya.B. Zel'dovich, "Teoriya Gorenii i Detonatsii v Gazakh" (Theory of Combustion and Detonation in Gases), TipogrAkadNauk, Moscow (1944) B) G.N. Abramovich & L.A. Vulis, DoklAkadN **55**, 111 (1947) (On the mechanics of propagation of detonation and combustion) C) Ya.B. Zel'dovich & K.S. Zarembo, ZhFizKhimii **22**, 427 (1948) (Investigation of a structure of a Bunsen flame) D) V.E. Ditsent & K.I. Shchelkin, ZhFizKhim **19**, 21 (1949) (Rapid combustion of gases in rough pipes) E) L.N. Khitrin, "Fizika Gorenii i Vzryva" (Physics of Combustion and Explosion", Izdat MGU, Moscow (1957)

- F) K.K. Andreev, "Termicheskoye Razlozheniye i Goreniye Vzryvchatykh Veshchestv" (Thermal Decomposition and Combustion of Explosive Substances), GosEnergolizdat, Moscow (1957) G) P. Breisacher et al, "Flame Front Structure of Lean Diborane-Air and Diborane-Hydrocarbon-Air Mixtures", 7th Symp Combstn (1959), pp 894-902
- H) M. Gerstein, "A Study of Alkylsilane Flames", Ibid, pp 903-05 I) P.L. Harrison, "The Combustion of Titanium and Zirconium", Ibid, pp 913-20 J) J.D. Lewis & A.C. Merrington, "Combustion of n-Heptane Spray in the Decomposition Products of Concentrated Hydrogen Peroxide", Ibid, pp 953-57
- K) Zel'dovich & Kompaneets (1960), 109-32 (Combustion with an induced ignition velocity) 188-91 (Combustion regime of Ditsent & Shchelkin for gases in rough pipes)
- L) F. Kaufman & N.J. Gerri, "Experimental Studies of Thermal Explosions and of Moderately Fast Reactions", 8th Symp Combstn (1962), pp 619-27 M) B. Brown & K.P. McArty, "Particle Size of Condensed Oxides from Combustion of Metalized Solid Propellants", 8th Symp Combstn (1962), pp 814-23
- N) K.K. Andreev & S.V. Chuiko, ZhFizKhim **37** (6), 1304-10 (1963) & CA **59**, 6190 (1963) (Combustion of powdered expls at high constant pressures) O) M.D. Horton & E.W. Price, "Dynamic Characteristics of Solid Propellant Combustion", 9th Symp Combstn (1963), pp 303-10 P) O.R. Irwin et al, "Deflagration Characteristics of Ammonium Perchlorate at High Pressures", 9th Symp Combstn (1963), pp 358-65 Q) M. Barrère & L. Nadaud, "Combustion of Spheres of Ammonium Perchlorate in a Stream of Combustible Gas", 10th Symp Combstn (1965), pp 1381-94 R) D.J. Carlson, "Emittance of Condensed Oxides in Solid Propellant Combustion Products", Ibid, pp 1413-24
- S) V. Lindner, "Propellant Performance: The Burning Process", pp 667-78 in Kirk & Othmer's Encyclopedia, Vol **8** (1965)
- T) K.I. Shchelkin, UspFizNauk **87** (2), 273-302 (1965) & CA **64**, 3274 (1966) (A review on the instability in the normal combustion and detonation in gases) U) R.P. Baumann & J.P. Picard, "Combustion Catalysis and Propellant Decomposition by Mass Spectrometry", USDeptComm AD **468333**, Avail CFSTI \$3.00, 23 pp (1965) (Engl); CA **66**, 8180-L (1967) V) P.G. Demidov, "Combustion and Properties of Combustible Substances", USDeptComm AD **621738**, Avail CFSTI \$3.00, 376 pp (1965) (Engl); CA **66**, 8180-R & 8181-L (1967) W) W.G. Struck & H.W. Reichenbach, "Investigation of Freely Expanding Spherical Combustion Waves Using Methods of High-Speed Photography", 11th Symp Combstn (1967), pp 677-82 X) M. Destriau & H. Heleschewitz, "Heterogeneous Processes in the Combustion of Gaseous Mixtures", Ibid, pp 1075-79 Y) J.R. Richard et al, "Spontaneous Ignition and Combustion of Sodium Droplets in Various Oxidizing Atmospheres at Atmospheric Pressure", 12th Symp Combstn, Poitiers, France, July 14-20, 1968 (Published in 1969), pp 39-48 Z) A. Maček & J. McKenzie Semple, "Experimental Burning Rates and Combustion AA) F.J. Kosdon, "Combustion of Vertical Cellulosic Cylinders in Air", Ibid, pp 41-43 (8 refs) BB) Louis Viaud, "Supersonic Combustion Research by ONERA", Ibid, pp 197-98
- Note: ONERA stands for "Office National d'Études et de Recherches Aeronautiques"
- CC) A. Ferri & H. Fox, "Analysis of Fluid Dynamics of Supersonic Combustion Process Controlled by Mixing", Ibid, pp 198-200 DD) J. Swithenbank & N. Chigier, "Vortex Mixing in Supersonic Combustion", Ibid, p 204
- Combustion, Detonative (or Explosive).* See Detonative (or Explosive) Combustion
- Combustion (Burning), Development (Transition) to Deflagration.* See under Deflagration, Development (Transition) from Combustion (Burning)
- Combustion (Burning), Development (Transition) to Detonation.* See under DETONATION (AND EXPLOSION), DEVELOPMENT (TRANSITION) FROM BURNING (COMBUSTION) OR DEFLAGRATION

Combustion (Burning), Explosion and Detonation of Gases, Vapors and Dusts. See Detonation, Explosion, Deflagration and Combustion of Gases, Vapors and Dusts

"Combustion, Explosion, and Shock Waves".

Title of Journal which is a translation from Russian. It is published by The Faraday Press, Inc, NY, 10011. In Vol 1, pp 3-4 (Jan-March 1965) there is an article by M.A. Lavrent'ev, entitled "Future Developments in the Field of Combustion and Explosion". He states that in the last few decades, Russian scientists have been studying with considerable success such questions as: the propagation of shock waves, effects of explosions in complex media, effects of a powerful explosion in a nonhomogeneous atmosphere and at great heights, formation and propagation of shock waves in shallow water, at the surface of a liquid, and in two-phase media. From the practical point of view, extreme interest was attached to explosions in soils, rocks, and metals. The findings have been applied in the use of expls for rock excavation & deep drilling, explosion forming, explosion welding, and so on

Many of the unsolved problems of physics and chemistry were concerned with combustion and detonation. A really well-developed scheme of normal combustion is seldom realized in nature. The most common form of gaseous combustion - *turbulent combustion* - was found to be the result of the hydrodynamic instability of the combustion process in a flow. Even in the simplest system, the physical scheme of turbulent combustion is very far from being perfectly understood. Just as in the analysis of *detonative combustion*, it is still possible to speak only of the universal instability of the hydrodynamic process accompanying the chemical transformation of matter. Actually, "turbulence" is hardly the term for the result of the manifestation of this instability - the appearance of a multifront shockwave in the detonation front. However, the derivation of a complete physical scheme of detonation (especially in relation to condensed expls) will eventually follow from further research in this field

The study of the combustion and detona-

tion of condensed systems is impossible without accurate information on the mechanism of chemical transformations under the corresponding thermal condition, ie, information which is at present extremely inadequate. This is a matter for the combined efforts of chemists, physicists, and workers in applied mechanics

Ref: C.G. Dunkle, private communication, Dec 1967

Combustion, Explosive. See Detonative (or Explosive) Combustion

Combustion to Explosion, Transition. See under Detonation (or Explosion), Development (or Transition) from Combustion (or Burning) or from Deflagration

Combustion, Heat of. Its definition is given in Vol 2 of Encycl, p C9-L, under Calorific Value and a brief description is given on pp C10 & C11. More complete description is given in this Section under Detonation (and Explosion), Heats of

Combustion Instability. See Burning (Combustion) Instability in Propellants

Combustion Kinetics, Importance in Rocket Propellants of. A brief review of the relations between the equations for specific impulse and the several equations used in explaining combustion reactions were given by: A. van Tiggelen, *Compt Rend Congr Internl-Chim* 31^e, Liège 1958 (Pub as *IndChimBelge*, Suppl) 1, Ind 25-8 (Pub 1959) (in French)

Combustion Knock. A nearly instantaneous and very high pressure expln of a compressed mixt of fuel and air in an internal combustion engine. It is undesired transition from deflagration to detonation as result of a two-stage or multi-stage ignition ahead of the moving flame front. In combustion knock a large proportion of the energy is given out as radiant energy and absorbed by the walls of the engine, thus reducing the available mechanical energy (Ref 1). Several theoretical explanations of this phenomenon are given in Ref 2

Jost (Ref 3) investigated knock reactions in a rapid compression apparatus, while recording pressure by rapid photography. He also followed the reaction by taking samples of gas for analysis. He succeeded in investigating the highly sensitive hydrogen-oxygen reaction and the results showed that it is highly improbable that any hot-point effects are present. Detailed results are given for single- and two-stage ignition of hydrocarbons with air

Walsh (Ref 5) discussed the knock ratings of fuels

The compds to prevent knock which is undesirable in internal combustion engines were described as "Antidetonating or Antiknock Compounds" in Vol 1 of Encycl, pp A462-A463

Addnl information on antiknock compds is given in Refs 4 & 6

Refs: 1) HackhDict (1944), 471 2) Dunkle's Syllabus (1957-1958), 133-34 & 208 3) W. Jost, 9thSympCombstn (1963), 1013-22 4) W.L. Richardson et al, Ibid, 1023-33 (Organolead antiknock agents - their performance and mode of action) 5) A.D. Walsh, Ibid, 1046-55 (The knock rating of fuels) 6) S. Curry, Ibid, 1056-68 (Effect of antiknocks on flame propagation in spark ignition engine)

Combustion, Nuclear in Rockets. Study conducted by E. Sanger was described in *Astronomica Acta* 1, Fascicule 2, pp 61-8 (1955); Engl translation NACA TM 1405 (April 1957)

Combustion, Propagation of. See G.N. Abramovich & L.A. Vulis, *DoklAkadN* 55, 111 (1947) (On the mechanics of propagation of detonation and combustion)

Combustion of Propellants for Artillery Weapons and Small Arms. See *Burning and Burning Characteristics of Propellants for Artillery Weapons and Small Arms* in, Vol 2, p B346 and *Combustion of Propellants* in Vol 3, p C427-L

Combustion of Propellants for Rockets. See Vol 3, p C428-L; also "Burning and Burning Characteristics of Propellants for Rockets",

Vol 2, p B350-R; and the following

Addnl Refs: A₁) L. Green, Jr, *Jet Propulsion* 24, 9 (1954) (Erosive burning of some composite solid proplnts) A₂) E.W. Price, *Ibid*, 25, 61 (1955) (Algebraic soln of the problem of erosion) B) J.M. Lenoir & G. Robillard, 6th SympCombstn (1957), 663 (Erosive burning of proplnts) C) M. Summerfield et al, "Burning Mechanism of Ammonium Perchlorate Propellants", ARS 13th Annual Meeting, Nov 1958, 238-58 (Preprint) D) G.S. Gill et al, "Determination of Rocket Motor Combustion Parameters by Means of a Diverging Reactor", 7th SympCombstn (1959), 712-42 E₁) Sin-I Cheng, "Unstable Combustion in Solid-Propellant Rocket Motors", 8th SympCombstn (1962), pp 81-96 E₂) J. Nichol et al, "Ionization in Rocket Flames", *Ibid*, pp 235-41 F₁) J.D. Lewis & D. Harrison, "A Study of Combustion and Recombination Reactions During the Nozzle Expansion Process of a Liquid Propellant Rocket Engine", *Ibid*, pp 366-74 F₂) W.E. Johnson & W. Nachbar, "Deflagration Limits in the Steady Linear Burning of a Monopropellant With Application of Ammonium Perchlorate", *Ibid*, pp 678-88 G₁) J. Vandekerckhove & A. Jaumotte, "Remarks on the Burning Mechanism and Erosive Burning of Ammonium Perchlorate Propellants", *Ibid*, pp 689-93 G₂) G.K. Adams et al, "Combustion of Propellants Based on Ammonium Perchlorate", *Ibid*, p 693-705 H₁) J. Hershkowitz, F. Schwartz & J.V.R. Kaufman, "Combustion of Loose Granular Mixtures of Potassium Perchlorate and Aluminum", *Ibid*, pp 720-27 H₂) L.A. Dickinson et al, "Erosive Burning of Polyurethane Propellants in Rocket Engines", *Ibid*, pp 754-59 H₃) S. Kumagai & T. Sakai, "Ignition of Solid Propellants by Periodic Heating with Special Reference to Instability in Solid Propellant Rockets", *Ibid*, pp 873-86 I₁) M. Barrère & J.J. Bernard, "Combustion Instability of Solid Propellants With Time Delay Distinction", *Ibid*, pp 886-94 I₂) H.B. Mathes, "Measurement Problems in Research of Unstable Combustion of Solid Rocket Propellants", *Ibid*, pp 894-903 J₁) F.T. McClure, Chairman of 12 Member Panel, "Solid Propellant Combustion Instability", A Discussion, *Ibid*, pp

- 904-32 J₂) C. Sanchez Tarifa et al, "Combustion of Liquid Monopropellants and Bipropellants in Droplets", *Ibid*, pp 1035-56
- K₁) A.C. Antoine, "The Mechanism of Burning of Liquid Hydrazine", *Ibid*, pp 1057-59
- K₂) M.L.J. Bernard & J. Dufour, "On the Existence of Detonation Conditions in the Combustion of Some Nitric Acid Propellants", *Ibid*, pp 1074-84 K₃) R.B. Lawhead, "Photographic Studies of Combustion Processes in Liquid Propellant Rockets", *Ibid*, 1140-51
- L) S. Lambiris et al, "Stable Combustion Processes in Liquid Propellant Rocket Engines", 5th Colloquium of Combustion and Propulsion Panel, AGARD (Advisory Group of Aeronautical Research and Development), Braunschweig, Germany, April 1962
- M₁) R.B. Lawhead & L.P. Combs, "Modelling Techniques for Liquid Propellant Rocket Combustion Processes", 9th Symp Combustn (1963), pp 973-81 M₂) R. Priem, "Theoretical and Experimental Models for Unstable Rocket Combustor", *Ibid*, 982-92 M₃) R.W. Hart & J.F. Bird, "Scaling Problems Associated With Unstable Burning in Solid Propellant Rockets", *Ibid*, 993-1004 M₄) M.D. Horton & D.W. Rice, *Combustn Flame* **8**(1), 21-8 (1964) & *CA* **60**, 14325 (1964) (Effect of compositional variables upon oscillatory combustion of solid rocket propellants) N₁) R.W. Hart & F.T. McClure, "Theory of Acoustic Instability in Solid Propellant Rocket Combustion", 10th Symp Combustn (1965), pp 1047-65
- N₂) E.W. Price, "Experimental Solid Rocket Combustion Instability", *Ibid*, pp 1067-82
- O₁) R.S. Levine, "Experimental Status of High Frequency Liquid Rocket Combustion Instability", *Ibid*, pp 1083-99 O₂) L. Crocco, "Theoretical Studies of Liquid-Propellant Rocket Instability", *Ibid*, pp 1101-28
- P₁) G.A. McD. Cummings & A.R. Hall, "Perchloric Acid Flames: Premixed Flames With Methane and Other Fuels", *Ibid*, 1365-72
- P₂) D.J. Carlson, "Emission of Condensed Oxides in Solid Propellants Combustion Products", *Ibid*, 1413-24 Q₁) *Ibid*, "Perchloric Acid Flames: Some Flame Temperatures and Burning Velocities", Ministry of Aviation, RPE Tech Rept **65/5** (1965) Q₂) G.S. Pearson, "Perchloric Acid Flames: Methane Rich Flames", *Ibid*, Tech Rept **65/6** (1965)
- Q₃) V. Lindner, pp 716-17 in Kirk & Othmer's *Encycl*, Vol **8** (1965) (Burning rate detn of rocket proplnts by "strand burning method")
- R₁) R.J. Zabelka, "Combustion of Several Hybrid Rocket Fuels", Univ Microfilms, Ann Arbor, Michigan, Order No **65-2668**, 247 pp. Dissertation Abstract **26**(4), 2091-92 (1965) (Engl); *CA* **64**, 3273 (1966) K₂) F. Solimosi & K. Fonagy, "Effect of Cadmium Oxide and Cadmium Perchlorate on the Decomposition and Ignition of Ammonium Perchlorate" 11th Symp Combustn (1967), 429-37 S) P.W.M. Jacobs & A. Russel-Jones, "Thermal Decomposition and Ignition of Mixtures of Ammonium Perchlorate + Copper Chromite", *Ibid*, 457-62
- T) J.D. Hightower & E.W. Price, "Combustion of Ammonium Perchlorate", *Ibid*, 463-72
- U) H. Selzer, "Temperature Profile Beneath the Burning Surface of a Composite Ammonium Perchlorate Propellant", *Ibid*, 439-46 V₁) J. Powling, "Experiments Relating to Combustion of Ammonium Perchlorate-Based Propellants", *Ibid*, 447-56 V₂) G.M. Faeth et al, "Supercritical Bipropellant Droplet Combustion", 12th Symp Combustn, Poitiers, France, July 14-20 (1968) (pub 1969), pp 9-18 W) B.T. Zinn & C.T. Savell, "A Theoretical Study of Three-Dimensional Combustion Instability in Liquid-Propellant Rocket Engines", *Ibid*, pp 139-47 X) M.W. Beckstead et al, "Combustion Instability of Solid Propellants", *Ibid*, pp 203-11
- Commercial or Industrial Explosives.* See Vol 3 of *Encycl*, pp C434 to C460
- Composite Explosives.* See Binary, Ternary and Quaternary Mixtures in Vol 2, pp B116 to B120
- Composite Explosives, Detonation (and Explosion) of.* See Detonation (and Explosion) of Composite Explosives
- Composite Propellants.* See Vol 3, p C464-L
- Composition of Products of Detonation (and Explosion).* See Detonation (and Explosion), Products of

Compressibility of Explosives. See Vol 3, p C491-L

Compressibility of Explosives under Explosive Attack. See Cook(1958), 210-13

Compressibility Factor. See under "Corresponding States"; Law of, pD194-R

Compressibility vs Pressure in Shock Waves. See Cook (1958), 329-41

Compressibility of Propellants. See Vol 3, p C491-R

Compression of Solids by Strong Shock Waves is discussed by W.H. Rice et al in "Solid States Physics", edits F. Seitz & D. Turnbull, Academic Press, NY (1958), pp 1-63

Compression Tests for Determination of Brisance. See Vol 3, p C492-L

Compressive and Elastic Properties of Solids Under Explosive Attack. Title of Chap 9 in Cook(1958), 206-25 (23 refs)

Compressive Strength of Rocks Under Explosive Attack. See Cook(1958), 339-41

Combustion of Pyrotechnic Compositions. See Vol 2, p B355-R - "Burning and Burning Characteristics of Pyrotechnic Compositions"

Combustion Rate (or Burning Rate) Catalysts. See Vol 3, p C429-L

Combustion, Spontaneous or Self-Ignition. See Vol 3, p C429-R

Combustion (Flame) Temperature of Explosives; Measurements. Combustion temperatures of PETN, RDX & Tetryl were measured at 20-100 atm in a constant-pressure bomb under a N₂ atmosphere (Refs 2 & 3). The absorptivities of the PETN and Hexogen flames were 0.1-0.3 and that of the Tetryl flame 0.8-0.9. In all cases the flame absorptivity increased toward the surface of the charge. If secondary explosives are volatile, as noted by Belyaev

(Ref 1), the temperature in the condensed phase cannot rise indefinitely; at some instant, very strong vaporization fixes a limit to further temperature rise. The dispersal of the condensed phase along with vaporization of the explosive leads to an increase in the absorptivity of the flame brush at the surface

The flame temperatures of PETN and RDX rise rapidly from about 2900 and 2700°K; respectively, at 20 atm to 3250 and 3050°K, respectively, at 60 atm, and thence slowly to 3300 and 3100°K, respectively, at 100 atm. Throught the range 20-100 atm the Tetryl flame temperature rose only slowly, from 2600 to about 2650°K. In all cases the measured temps were lower than the calculated temperatures

Refs: 1) A.F. Belyaev, "Doctoral Dissertation", Moscow(1946) 2) P.F. Pokhil et al, ZhurFizicheskoiKhimii **34**, No 5, 539-40 (1960) & 1131(1960) (Apparatus for determination of temperature at different heights in the jet of flame from Gunpowder) 3) P.F. Pokhil & V.M. Maltsev, ZhFizKhim **39**, No 4, 978-79(1965) (Engl transl of paper of Pokhil et al

Combustion (Flame) Temperature of Propellants; Measurements. Optical methods are the most widely used for the measurement of flame temperature. Since the study of a flame depends not only on temperature, but also on other factors (the radiation factor, the chemical reactions in the gases, etc), it is necessary first of all to study the spectral characteristics of the objects under investigation. Flame spectra were studied in Russia on the ISP-51 spectrograph

In the pressure interval studied, (147-980) · 10⁴ newton · m⁻², the flame spectrum of NG powder and RDX was continuous except for several lines of the alkali metals. This permitted determination of temperature by optical methods

When combustion proceeds under high pressure, separate atoms and molecules may no longer be regarded as isolated systems. Owing to their interaction, broad energy bands arise from the sharp energy levels of the atoms and molecules. The continuous spectra of flames

under elevated pressures are largely due to precisely this cause. Flames of condensed systems radiate an unbroken spectrum also because of the illumination of the carbon particles formed during the combustion. To determine temperature of the flame envelope (brush) of condensed systems by the color method, the apparatus (Ref 1) (collimator-electronic light measurer) measures the relative brilliance of two wavelengths and the absorptive capacity within them. The temperature of the envelope (brush) could be measured over the range 1500-3500° K

The use of the infrared pyrometric method extended significantly the range of measurement. Infrared pyrometry has the advantage of being equally adaptable to luminous low-transparency and to nonluminous flames. With this apparatus (Ref 2) the temperature in the flame brush could be determined in the range 600-3500° K. A PbS photoresistor was used as the infrared radiation receiver; it has significant sensitivity and low visual persistence

Refs: 1) P.F. Pokhil et al, *Inzhenerno-Fizicheskiy Zhurnal* (Engineering-Physical Journal) **34**, No 5 (1960) 2) *Ibid* **35**, No 5 (1961) 3) P.F. Pokhil & V.M. Maltsev, *Ibid* **6**, No 6, pp 94-9 (1963) (Engl translation entitled "Combustion Mechanism of Propellants")

Combustion Theories as Applied to Solid Propellants. See Vol 3 of *Encycl*, p C430-L

Combustion and Thermal Decomposition of Explosives. See K.K. Andreev, *Explosivstoffe* **10**(10), 203-12 (1962); *CA* **58**, 3263 (1963). This paper is also listed in this Section under Detonation (or Explosion), Development (or Transition) from Combustion (or Burning) or from Deflagration

Combustion Wave Propagation. See Vol 3 of *Encycl*, p C433-R

COMPUTERS AND COMPUTER PROGRAMS.

Computer is a machine designed to determine the answer to a specific mathematical problem

The term usually excludes its predecessors: "abacus" (which dates from 600BC

and considered as an early ancestor of "digital computers"); "slide rule" (constructed by Oughtred, based on logarithms invented ca 1600 by Scottish mathematician John Napier; the slide rule is one of the predecessors of "analog computers"); and "calculating machine", which may be considered as a "mechanized abacus" (invented ca 1642 independently by Blaise Pascal in France and Gottfried Leibnitz in Germany) (Ref 1, pp 6, 46 & 47)

Computers are subdivided into "digital" and "analog" branches:

I. Computer, Digital. Its name is derived from "digit" since it uses digits to count the numbers. It works on the principle of counting, as distinguished from measuring. There is a family of computers which includes electrical relay computers used in telephone exchanges and complex electronic calculators as *ENIAC* (Electronic Numerical Integrator and Computer), used during WWII at Ballistic Research Laboratories, Aberdeen Proving Ground, Maryland. Its earlier model is obsolete (Ref 3, p 107 & Addnl Ref A)

Digital computers use either a decimal or binary system of notations (Ref 3, p 78). The "binary system" is a number system which uses two symbols (usually denoted by "0" and "1") and has two as its base, just as the "decimal system" uses ten symbols (0, 1, 2, ... 9) and the base ten (Ref 3, p38). Digital computers are also called "discrete", because they recognize only discrete values, 0, 1, 2 etc (Ref 1, p 45)

For description of digital computers, see Ref 1, pp 95-149 and Addn Refs C, D, E₁, F₁ & O)

B. Computer, Analog. "Whereas the digital computer identifies a number by counting certain discrete things like gear teeth or events like rotation of a shaft, the "analog" or "continuous" computer identifies a number by measuring something like the distance between two marks on a scale or the displacement of a slide" (Ref 1, p 55). In other words, an analog computer works on the principle of measuring, as distinguished from counting which is used in digital computers. In these computers, the measurements ob-

tained, as voltages, resistance, etc are translated into desired data. Radar and gun directors use this type of computer (Ref 3, p 78)

Analog computers can be subdivided into "function computers" and "integrating computers". Their development will be briefly described here under "History of Computers"

The so-called *differential analyzer* developed ca 1930 by Vannevar Bush, is an analog computer used especially for the rapid solution of problems by differential calculus. Its improved version was used during WWII for solving ballistic problems (Ref 1, pp 60-61 & Ref 3, p 96)

A group of computers known as *counting computers* is neither analog, because they do not rely on the measurement of a continuous physical variable (like a length or voltage), nor digital in the sense of representing numbers in a radix or digital notation. Instead, they recognize a succession of discrete events by a counting process, and the term "counting computers" has been chosen to distinguish them from digital and analog computers. A mechanical component, called the function unit, representing a function of one variable, was devised by Stibitz in 1946 and in 1951, an "electronic counting computer", the *Maddida*, was invented. The *Maddida* and its modifications count electrical pulses and perform mathematical operations by reducing them to counts. Electronic counting computers have been applied to the solution of differential equations, to coordinate conversions, and to similar problems with a precision of which analog devices are not capable (Ref 1, pp 61-2)

Analog computers are described more fully in Ref 1, pp 150-74 and Addnl Refs C, G, H and J)

Computer Hybrid. It is a combination of digital and analog computers, such as the Electronics Association, Inc Hybrid Computer, Model 8900 composed of the Digital 8400 and Analog 8800 computers (Ref 26)

History of Computers. The idea of "automatic computer" was first conceived ca 1786 by J.H. Müller, but the device was not constructed due to technical difficulties encountered in the 18th century

Same technical difficulties faced English inventor Charles Babbage, who in 1812, at the age of twenty, conceived the idea of an "automatic" computer, known as "difference engine". After working on the project for 10 years he constructed a small working model which operated so successfully, that the British Government consented to finance the construction of a full-sized machine. After about another ten years of work, the machine was finally constructed. As there were no electrical motors, relays, etc in those days, the machine was mechanically-operated by means of many gears, set on shafts rotating in bushings. This machine proved too complicated for use and was put in storage. It is now located in the Science Museum, South Kensington, England (Ref 1, pp 48-9)

As the "difference engine" could be used only for addition and subtraction (as well as printing the results), Babbage considered it inadequate and decided to extend its capabilities to multiplication and division. He performed all necessary designing and started construction, but the work was not completed during his lifetime due to lack of funds and technical difficulties. His machine, nevertheless, was the prototype of modern computers and at least two machines, inspired by Babbage's design, were built during his lifetime. One was in Sweden by George Scheutz and another in Great Britain. After this time, for nearly 100 years no more new large automatic computers were attempted, partly because of technical difficulties and also enormous cost (Ref 1, pp 49-51)

The invention of punch-card technique was done in 1890 by Herman Hollerith at the US Bureau of Census and used at first for adding up the number of inhabitants in US each tenth year. The technique was greatly expanded beginning in the 1930's and many scientific applications of punched-card equipment have been found as a computing aid. In the punched-card machines, if a calculation involved a sequence of many arithmetic operations, the machines were set up for one of these operations, which was performed on the data punched in as many cards as might be required. The machines were then

set up again for the next step, and the cards passed thru a 2nd time, receiving the information obt'd at this new step in the form of addnl punching, and so on, until all the steps had been completed. The idea of providing a machine with controls that would cause it to go thru the full sequence of steps on each set of data (which was proposed by Babbage but not realized, as mentioned above) was finally solved by Howard Aiken and George Stibitz, who began working independently ca 1937 on sequentially operated automatic "digital computers" (qv). The first complex-number automatic computer was demonstrated at a Meeting of the American Mathematical Society in Hanover, New Hampshire, Sept 1940. The inventor was Stibitz and constructor, the Bell Telephone Labs, under the direction of S.B. Williams (Ref 1, pp 51-4)

The advent of WWII and the availability of US Govt funds for defense, greatly enhanced the development of digital computers. The next steps after 1940 were: a) The "Relay-Interpolator" invented by Stibitz in 1942. This was a specialized computer capable of operating under the control of instructions recorded on tape; b) The "Ballistic Computer", built by Stibitz in 1943 is located at Fort Bliss, Texas; c) Mark 22 Error Computer for the Naval Research Laboratory at Washington, DC. It was of the same construction as the "ballistic computer"; d) "Computer Mark I" invented before 1944 by Howard Aiken, using a number of IBM computing elements; e) Electronic computers developed at Univ of Pennsylvania by J. Mauchly, J.P. Eckert & H. Goldstine, among them the *Eniac*, which contained thousands of electron tubes. It was followed by *Edvac*, *Univac*, and *Binac*; f) Marks II, III, and IV of Aiken; and g) Models 4, 5, and 6 of the Bell Telephone Labs (Ref 1, pp 54-5)

History of analog computing may be subdivided into development of "function computers" and of "integrating computers", although the function-computing components and the integrating components have often appeared together in a single device. The earliest analog computers were primarily

function computers. This was true of Oughtred's slide rule of the 17th century and of all slide rules since. Next came the *nomogram*, a device that has its roots in the graphs of Descartes' analytical geometry. Descartes' idea was extended by Margetts in the longitude and horary tables published in 1791 for the guidance of mariners. Margetts also drew a "family" of curves, but as these curves were tedious to draw accurately, Lalanne suggested in 1842 a method for replacing them with straight lines. Final improvement in nomograms was done in 1890 by Maurice d'Ocagne and it was he who suggested the name "nomogram" (Ref 1, pp 57-8). Under the title "later function computers" is briefly described in Ref 1, p 61, the "electrical linear-equation solver", invented in 1933 by a Britisher, R.R.M. Mallock

The *integrating* devices appeared later than the functional devices. One of the earliest was the *planimeter* invented by a Bavarian engineer J.H. Hermann, ca 1815 for measuring on a piece of paper the area bounded by a closed curve. As the original device was not very accurate, Clerk Maxwell proposed in 1855 its modification. Although his idea was not applied to practice by him, it inspired James Thomson (brother of Lord Kelvin) to construct a planimeter, known as "ball-and-disk integrator", which has been widely used for many years. Practically at the same time Jakob Amsler constructed a device known as *polar planimeter* and, since it was simple in construction and inexpensive, about 12000 were sold in 30 years following the invention. Its design is almost unaltered in the planimeter of today. Another simple planimeter was the *hatchet planimeter* invented in 1887 by a Captain Prytz (Ref 1, pp 58-9)

Working independently, A. Abakonovicz in 1878 and C.V. Boys in 1882 devised the *integrator*, an instrument that drew the integral of an arbitrary function when the latter was plotted on a suitable scale on paper. A device for finding trigonometric functions (sines and cosines), known as *harmonic analyzer* was devised in 1876 by Lord Kelvin. Its construction was based on components of James Thomson's "ball-and-disk integrator".

A modification of Kelvin's device was introduced in 1898 by Michaelson & Stratton (Ref 1, pp 59-60)

Modern Computers. There are many machines on the market. Among the firms manufg them may be mentioned:

IBM (International Business Machines) Corp, White Plains, NY 10601 (Branches in principal cities in USA & foreign countries)
UNIVAC, Division of Sperry Rand Corp, Philadelphia, Pa 19116

RCA (Radio Corporation of America), Camden, NJ 08102 (Spectra 70 Series Computers)

Potter Instrument Co, Inc, Plainview, LI, NY 11803

Olivetti Underwood Corp, New York, NY 10016

Electro Data Division of Burroughs Corp, Pasadena, Calif (Manufacturers of "Datatron")
WANG Laboratories, Inc, Tewksbury, Massachusetts, 01876 (WANG 370 Calculating Computing System)

Electronic Associates, Inc, West Long Branch, NJ 07764 (Analog Computer Model 31R and 8800; Digital Computer Model 8400 and Hybrid Computer Model 8900)

Honeywell, Inc, Minneapolis, Minn (Computers Series 200, such as Honeywell 2200; they are similar to IBM 360)

Controlled Data Corp (CDC 3600 & 6600), Minneapolis, Minn

Burroughs Corp, Detroit, Mich 48232

Many computers which are used today will be obsolete tomorrow

Accdg to information obtd by Dunkle (Ref 27) from the IBM office in Washington, DC, computers IBM 610, 650, 704, 705 and 709 are now obsolete. They were of the "first generation" ("tube type") and were superseded by "transistor types", and these by the third generation "super-hybrid electronic types" of the system 360 line. This covers everything from small-scale (Types 30 or 40) to large-scale or specially-built, such as Type 91, but they use the same programming for all. Information about the use of IBM Computers for "explosives calculations" can be obtained from Director of Army Programs, IBM Corporation, 3833 North Fairfax Drive, Arlington, Va, 22203. As with IBM, the UNIVAC Computers are of different types for Government

(MIL-SPEC) and for commercial agencies. The UNIVAC 120 mentioned in one of the papers of the Western States Section Meeting in Los Angeles, Calif, 2-5 November 1959 is now obsolete

At Picatinny Arsenal there are at present (Nov 1968), two digital and one analog computers. A new "hybrid computer" (which comprises both digital and analog features) is planned to be installed in December 1968

The digital computers used at PicArnsn are the IBM 360, Model 40 and the IBM 360, Model 65. The former model is used primarily for rather simple processing of a large volume of administrative data, while the latter model is used mainly in the elaborate processing of meager quantities of scientific data. The analog computer used at PicArnsn is the Electronic Associates Incorporated Analog Computer Model 31R (Ref 26)

The Hybrid Computer planned to be installed is the Model 8900 of the Electronic Associates Inc, composed of the 8800 Analog and the 8400 Digital computers and its associated linkage (Ref 26)

An index of digital computer programs being developed or in use at PicArnsn is given in Addnl Ref O

The MANIAC is the name of a computer which was, accdg to Metropolis et al (Addnl Ref E2), used at Los Alamos Scientific Laboratory in conjunction with modified Monte Carlo integration (See further in this section)

Accdg to Fickett (Ref 29), MANIAC computer was constructed at the Los Alamos Scientific Laboratory and is still used after being modified and improved

Computer Program for a Digital Computer is a sequence of instructions which a computer carries out as it processes one or more sets of data. Such processing consists of either:
1) Rearranging and printing of data or
2) Generating new data from inputted data via use of mathematical equations or both (Ref 26)

Computer Program for an Analog Computer consists of a board on which electrical circuits are arranged to simulate a physical process which is expressible in mathematical terms and whose solution is desired (Ref 26)

Accdng to Wilkins (Ref 20), it has been shown that hydrodynamic codes are capable of accurately solving the equations in hydrodynamics. They, therefore, offer the means to perform calculations in conjunction with experiments and use an iterative technique to obtain otherwise inaccessible data. In addition, they serve an important role in setting up and interpreting experiments in high explosive research

In the paper of Kury et al (Ref 18, p 6), it has been stated: "The ability to calculate the performance of a system containing explosive and metal has, in general, been limited to simple idealized geometries. However, the advent of high speed, large memory computers such as IBM 7030 and CDC 6600 has changed this. With these computers the motion of metal in fairly complex geometries can now be accurately calculated using such hydrodynamic codes as **HEMP**", which is described in Refs 12 & 15. The computer program **SWAP** is described in Ref 13 and **SRATE** in Ref 17. There are also other codes described in Refs 21, 22, 23, 24 & 25. Many computer programs derive their names not from a scientific basis but rather from some incidental circumstance in the life of the programmer. For example, the code **TIGER** was named by W.H. Zwisler of SRI (Stanford Research Institute, Menlo Park, Calif) after his wife's nickname. An advertiser friend suggested that any product named "Tiger" would be very popular. The Tiger program is described in Ref 24b. The code **RUBY** is another arbitrary name which has no scientific basis (Ref 26). See also Addnl Ref P for Code **STARFIT**

The original function of the RUBY Program was to compute the C-J (Chapman-Jouguet) point for HE's assuming that the gaseous products obey the KW (Kistiakowsky-Wilson) equation of state [See under "Detonation (and Explosion), Equations of State Used in"] and that the solid products are either incompressible or obey an empirical equation of state of a form utilized by several workers for graphite. Such calcns have been done in the past and particularly by Cowan & Fickett (Addnl Ref I₂). In fact the only extension of the latter work, as far as the CJ point is con-

cerned consists in generalizing the problem so as to allow a maximum of two solid phases instead of only one. In addition to the CJ point itself the mathematical techniques of RUBY permit one to calculate points along the Hugoniot and isentrope curves pertaining to the detonation products. Additional options in the program allow a calculation of a grid of p,v points about the CJ point and shock propagation parameters such as shock velocity in inert media. In this case the program is based on a semi-empirical thermodynamic treatment of explosives in which there appear the adjustable parameters in a nonideal equation of state for hot dense detonation products, such as the Cowan & Fickett modification of the BKW (Becker-Kistiakowsky-Wilson) equation of state. Code RUBY has been written for IBM 709/7090, using "FORTRAN". At LRL (Lawrence Radiation Laboratory), Livermore, Calif, it has been used in conjunction with the master control program "MONITOR" (Refs 10, 11, 16 & 19 and Addnl Ref I₂)

Enclosed Fig is copied from UCRL-6815 (Ref 10, p 3), except that the words "POINT (P5-3)" and "(MIKHEL'SON LINE)" are inserted

TIGER Computer Program, described in Ref 24b, is now operational on Picatinny's IBM 360, Model 65 Computer. This computer code is suitable for calculating detonation parameters for both condensed & gaseous expls. The code was developed under a contract negotiated by the Terminal Ballistics Laboratory, Aberdeen, Md. The TIGER program was written by W.H. Zwisler of Stanford Research Institute and adapted to the Picatinny computer by R. Beck of Data Processing Systems Office & Jack Alster of the Explosives Laboratory, both of Picatinny Arsenal. TIGER represents a major improvement on the now well-known RUBY code. Whereas both codes are based on a one-dimensional thermohydrodynamic model which assumes the conversion of initial expl to hot dense detonation products and interconversions among them to proceed with infinite speed, TIGER is a lot easier to handle, provides more useful options, and serves as a suitable base for the incor-

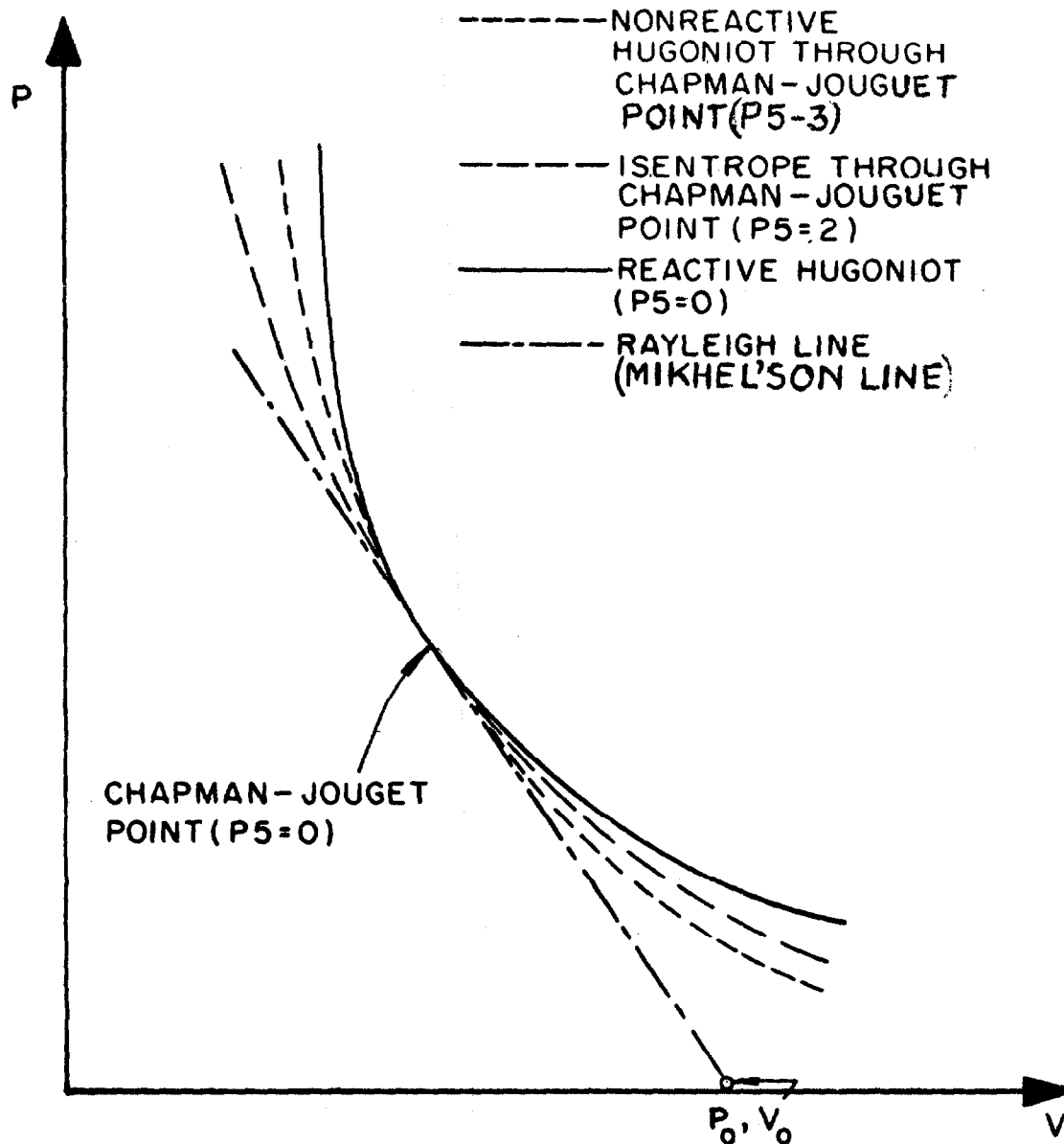

Fig Four Curves and CJ Point Determined by RUBY Computer Program

poration of refinements into detonation theory **Monte Carlo Methods** represent statistical techniques for solving certain problems in physics, chemistry, biology, operation research and other fields. There, no doubt, exist many digital computer programs which utilize these techniques and they may go under any conceivable name (Ref 26)

Monte Carlo methods comprise that branch of experimental mathematics which is concerned with experiments on random numbers (Addnl Ref N)

Accdg to Stibitz & Larrivee (Ref 1, pp 178-81), the method on random numbers was first applied to solving mathematical problems in 1855 by A. Smith of Aberdeen, Scotland and

the suggestion of using random sequences to solve nonstatistical problems came from John von Neumann (evidently during WWII). The reason for naming the method "Monte Carlo", as well as the year, author and journal of the first description of the method are not given in Ref 1

Accdg to Hammersley & Handscomb (Addnl Ref N, p 8), S. Ulam, J. von Neumann and E. Fermi independently rediscovered Monte Carlo methods ca 1944 and started its systematic development. They also ensured that their scientific colleagues should become aware of the possibilities, potentialities and physical applications. The real use of Monte Carlo methods as research tools is attributed to von Neumann & Ulam who applied them to random neutron diffusion in fissile material

Metropolis et al (Addnl Ref E₂) describe a general method, suitable for fast computing machines, for investigating such properties as equations of state for substances consisting of interacting individual molecules. The method consists of a modified Monte Carlo integration over configuration space. Results for the two-dimensional rigid-sphere system have been obtd on the Los Alamos Scientific Laboratory MANIAC. These results are compared to the free volume equation of state and to a four-term virial coefficient expansion. It is also stated that the Monte Carlo method used in investigation was that proposed independently by J.E. Mayer and S. Ulam. Mayer suggested the method as a tool to deal with the problem of the liquid state, while Ulam proposed it as a procedure of general usefulness

Monte Carlo method is described in Addnl Ref B

Many scientists used the method (besides Metropolis et al), among them W. Fickett, W.W. Wood, F.R. Parker, M.N. Rosenbluth, A.W. Rosenbluth, A.H. Teller, E. Teller, J.D. Jacobson, and others (See Addnl Refs F₂, I₁, K₁ & K₂)

Refs: 1) G.R. Stibitz & J.A. Larrivee, "Mathematics and Computers", McGraw-Hill, NY (1957) [Gives history of computers (pp 45-63) and describes among other chapters: "numerical analysis" (pp 65-94); "digital

computer components" (pp 95-127); "logical design of digital computers" (pp 128-49); "analog computers and simulators" (pp 150-74) and "computing with random numbers" (pp 175-91). The chapter on "computing with random numbers" contains a brief description of "Monte Carlo Method" (pp 178-91)] (See in the text) 2a) M.W. Evans & F.H. Harlow, LASL (Los Alamos Scientific Laboratory) Rept **2139** (Nov 1957) [Numerical method "Particle-in Cell", used later by A. Vidart et al (Ref 21) 2b) F.H. Harlow, LASL Rept **2301** (Sept 1959) (Description of "Particle-in Cell Method") 3) Glossary of Ord (1959), pp 78, 96 & 107 4) G.S. Bahn & E.E. Zukoski, Editors, "Kinetics, Equilibria and Performance of High Temperature Systems", Proceedings of the 1st Conference, Western States Section, The Combustion Institute, Los Angeles, Calif, 2-5 Nov 1959, published by Butterworths, Washington, DC (1960). This includes papers by: a) W.C. Moffatt et al, "The Thermodynamic Properties of the Products of H₂/O₂ Combustion at Elevated Temperature", pp 53-7 (A program was developed for use in the "IBM 704 Digital Computer" which yields the compn and thermodynamic properties of the products of combustion of H₂/O₂ mixtures) b) D.G. McMahon & R. Roback, "Machine Computation of Chemical Equilibria in Reacting Systems", pp 105-14 (The computation procedure using IBM 704 Digital Computer for calcg the properties of detonation and shock waves as well as for other purposes is described) c) R.M. Mentz, "Programs for Computing Equilibrium Temperature and Composition of Chemical Reactions", pp 115-22 (Description of the generalized program for the "IBM 704 Digital Computer" developed by the Westinghouse Electric Corp, Aviation Gas Turbine Division) d) R.L. Wilkins, "Note on the Linearization Method for Computing Chemical Equilibrium in Complex Systems", pp 123-27 (Use of IBM 704 and 709 Computers in that method is described) e) J.D. Brazeale, "Performance Calculations Using an IBM 650 Computer", pp 128-3 (Solution of the systems involving complex chemi-

cal equilibria is greatly facilitated by use of computers. As an example, the program is described based on the method developed by S.R. Brinkley for the determination of the equilibrium compn and thermodynamic properties of combustion gases)

f) G.S. Bahn, "Hand Calculation of Equilibrium Compositions as a Learned Habit and Speed-Up Effected with the IBM 610 Computer", pp 137-40 (In some cases the need for a quick answer before an IBM 740, or its equivalent, can be available a hand-operated IBM 610 may be used)

g) L.J. Gordon & H.E. Boerlin, "A Practical Approach to Computer Programming for Specific Impulse Calculations", pp 152-60 (Use of IBM 704 Computer for general thermodynamic calcs, including specific impulse)

h) R.W. Smith, Jr & E. Cook, "Calculation of Thermodynamic Properties of Combustion Gases with a Small Punch-Card Electronic Computer", pp 161-65 (Description of small computer which can be used if larger models are not available)

i) L.M. Naphthali, "Computing Complex Chemical Equilibria by Minimizing Free Energy", pp 181-83 (Complex chemical equilibria computed by the method suggested by W.B. White et al is described)

j) H.A. Friedman & E.F. Eckel, "Methods for Computing the Theoretical Behavior of Premixed Reaction Flowing Gases", pp 209-18 [Use of IBM 709 EDPM (Electronic Data Processing Machine)]

5) W.B. Goad, LAMS (Los Alamos Scientific Laboratory, Los Alamos, New Mexico) Manuscript **2365** (Nov 1960) (Description of one of the numerical methods used by A. Vidart et al) (Ref 21)

6) R. Courant & K.O. Friedrichs, "Supersonic Flow and Shock Waves", Interscience, NY(1961) (3rd Printing of original 1948 edition), pp 40-8 (Characteristic curves and characteristic equations)

7) I.M. Fyfe et al, "On the Numerical Solution of the Hydrodynamic Equations", SIAM (Society of Industrial and Applied Mathematicians) Review **3**(4), 298-308 (Oct 1961) (Mesh Method)

7a) Anon, "Computer Tackles Ring Conformation Energies", C&EN, p 40, Nov 20, 1961

8) L. Fox, Ed, "Numerical Solution of Ordinary and Partial Differential Equations,

"Pergamon Press, NY(1962), Chapter 26:

"Solution of Characteristics of the Equations of One Dimensional Unsteady Flow", by A.E. Glennie (Method of Characteristics is described); Chapter 27: "Finite Difference Methods for One-Dimensional Unsteady Flow",

by N.E. Hoskin & B.W. Pearson (Mesh Method is described)

9) H.D. Huskey & G.A. Korn, "Computer Handbook", McGraw-Hill, NY(1962)

10) H.B. Levine & R.E. Sharples, "Operator's Manual for RUBY", Univ of Calif, Lawrence Radiation Lab, Livermore, Calif, Rept **UCRL-6815**(1962) (Available from Office of Technical Services, US Dept of Commerce, Washington, 25, DC) (The name changed now to "Clearinghouse for Scientific and Technical Information", US Dept of Commerce, Springfield, Va, 22151)

11) Donna Price & H. Hurwitz, "RUBY Code Calculations of Detonation Properties, C-H-N-O Systems", **NOLTR 63-216**(1963)

12) M.L. Wilkins, Ibid, Rept **UCRL-7322**(1963) (Description of hydrodynamic code HEMP)

13) L.M. Barker, "SWAP - A Computer Program for Shock Wave Analysis", Sandia Corp Rept **SC-RR-4796**(1963)

13a) C.L. Mader, "STRECH-SIN: A Code for Computing One-Dimensional Reactive Hydrodynamic Problems", LASL Rept **TID-18571**(1963)

14) B. Alder et al, eds, "Methods in Computational Physics", Academic Press, NY, Vol 1(1963), "Statistical Physics"; Vol 2(1963), "Quantum Mechanics"(1963)

15) Ibid, Vol 3(1964), "Fundamental Methods in Hydrodynamics", which includes "Hydrodynamic Code HEMP", by M.L. Wilkins, pp 211-63 and "Method of Characteristics", by N.E. Hoskin, pp 265-93

15a) V. Lindner, "Computational Techniques in Propellant Evaluation", in Kirk & Othmer, 2nd edit, **8** (1965), pp 715-16

16) H. Hurwitz, "Calculation of Detonation Parameters with the RUBY Code", NavOrdLab, White Oak, Md, TechRept **NOLTR 63-205** (1965)

17) B.M. Butcher, "A Computer Program 'SRATE' for the Study of Strain-Rate Sensitive Stress Wave Propagation", SandiaCorpRept **SC-RR-65-298**(1965)

18) J.W. Kury et al, "Metal Acceleration by Chemical Explosives", 4thONRSympDeton (1965), pp 3-13

19) J. Hershkowitz, "Anomalous Isentrope Results Obtained with the RUBY Computer Program", Ibid, pp 168-75

- 20) M.L. Wilkins, "The Use of One- and Two-Dimensional Hydrodynamic Machine Calculation in High Explosives Research", *Ibid*, pp 519-26 (Calcs made by means of code HEMP)
- 21) A. Vidart et al, "Calculation of Unsteady 2-D Flows by Various Numerical Methods", *Ibid*, pp 527-37 [A brief description of the following numerical methods for calculation: a) "Finite Difference Scheme in Lagrangian Coordinates", previously described by Goad (Ref 5); b) Particle-in Cell Method, previously described by Evans & Harlow (Ref 1) and Harlow (Ref 2); c) Particle and Gradient (or Pique-Peg) Method; and d) Method of Generalized Integral Methods c) & d) are described in paper of Vidart et al (pp 528-31)
- 22) B.D. Lambourn & J.E. Hartley, "The Calculation of Hydrodynamic Behaviour of Plane One Dimensional Explosive/Metal Systems", *Ibid*, p 538-52 [Use of the "Method of Characteristics" in the code NIP (Normal Initiation Program) is described and compared with the "Mesh Methods". Method of Characteristics was described by Courant & Friedrichs (Ref 6) and Glennie (Ref 8). Mesh Method was described by Hoskin & Pearson (Ref 8) and by Fyfe et al (Ref 7)
- 23) B. Alder et al, "Methods in Computational Physics", Academic Press, NY, Vol 4 (1965), "Applications in Hydrodynamics", Vol 5 (1966), "Nuclear Particle Kinematics"; Vol 6 (1966), "Nuclear Physics"; and Vol 7 (1967), "Astrophysics"
- 23a) W.R. Gage & C.L. Mader, "2DE - A Two-Dimensional Eulerian Hydrodynamic Code for Computing One-Component Reactive Hydrodynamic Problems", Los Alamos Scientific Laboratory Report **LA-3629-MS** (1966)
- 23b) C.L. Mader, "FORTRAN-SIN - A One-Dimensional Hydrodynamic Code for Problems Which Include Chemical Reactions, Elastic-Plastic Flow, Spalling, and Phase Transitions", Los Alamos Scientific Laboratory Report **LA-3720** (1967)
- 24) R.C. Sprowls, "Computers. A Programming Problem Approach", Harper & Rowe, NY (1968)
- 24a) Anon, "Computer Simulations Aid Explosion Research", *C&EN*, pp 48 & 49, April 8, 1968
- 24b) W.E. Wiebenson Jr, W.H. Zwisler & L.B. Seely (of SRI) and S.R. Brinkley, Jr (of Combustion & Explosives Res, Inc, Pittsburgh, Pa), "TIGER Computer Program Documentation" Part IV. "User's Guide", Ballistics Research Laboratories (BRL), Aberdeen, Md (March 1968) [Contract DA-04-200-AMC-3226(X)]. Parts I, II & III were not published at the time of writing this Section
- 25) Anon, "Computers' Analytical Role Extended", *C&EN*, March 18, 1968, pp 44, 48, 52 & 54 [At the exhibit of the "1968 Pittsburgh Conference on Analytical Chemistry and Applied Spectroscopy", held in Cleveland, Ohio (See *C&EN*, March 11, 1968, p10) were shown the computers of DEC (Digital Equipment Corp) and of IBM (International Business Machine Corporation). The DEC exhibited "Gas Chrom-8 Computer" system for gas chromatography and IBM-Model 1800 and 1130. There were also exhibited other systems, among them smaller inexpensive computers. There were also shown slides on results of work with computers done by S. Sasaki & H. Abe of Japan's Tohoku University and by T. Kato of Japan Electron Optics Laboratory Co, Ltd
- 26) Jack Alster, Picatinny Arsenal; private communication, July 1968
- 27) C.G. Dunkle, Silver Spring, Md; private communication, August 1968
- 28) "WANG 370 Calculating Computing System", *C&EN*, Sept 16, 1968, p 68
- 29) W. Fickett, Los Alamos Scientific Laboratory, Los Alamos, New Mexico; private communication, November 1968
- Additional References:* A) Anon, "Electronic Calculator: Eniac", *SciAmer* **174**, 248 (June 1946)
- B) A.S. Householder, ed, "Monte Carlo Method", Applied Mathematics Series No 12, US Natl Bur Stds, Govt Prg Off, Washington, DC (1951)
- C) F. Grueneberger, "Computing Manual", Univ Wisconsin Press, Madison, Wis (1952)
- D) Anon, "Components of Digital Computers", *IndustMath* **3**, 92 (1952)
- E₁) A.D. Booth & K.H.V. Booth, "Automatic Digital Calculators", Academic Press, NY, (1953)
- E₂) N. Metropolis et al, "Equation of State Calculations by Fast Computing Machines", *JChemPhys* **21**, 1087-92 (1953) (Use of modified Monte Carlo integration and MANIAC computer are described)
- F₁) N.M. Blachman, "A Survey of Automatic Digital Computers", US Dept Commerce, Office of Technical Services, Washington, DC (1953)
- F₂) M.N. Rosenbluth

- & A.W. Rosenbluth, *JChemPhys* **22**, 881-84 (1954) (Application of Monte Carlo method, as described in Ref E₂ for obtaining the equation of state of a system of interacting particles)
- G) C.A.C. Waas, "Introduction to Electronic Analogue Computers", Pergamon Press, London (1955)
- H) Anon, "Electric Analog Computers: Classification, Design and Application", *AnnNewYorkAcadSci* **60**, 884 (1955)
- I₁) D.D. McCracken, "The Monte Carlo Method", *SciAmer* **192**, 90 (May 1955)
- I₂) R.D. Cowan & W. Fickett, *JChemPhys* **24**, 932 (1956) (Calculations using RUBY computer program)
- J) G.A. Korn & T.M. Korn, "Electronic Analog Computers" (D-C Analog Computers), 2nd Ed, McGraw-Hill, NY (1956)
- K₁) W.W. Wood & F.R. Parker, *JChemPhys* **27**, 720-33 (1957) [Use of Monte Carlo calculations for three-dimensional molecules interacting in pairs according to Lennard-Jones (LJ) potential. The program was carried on IBM type 701 & 704 computers]
- K₂) W.W. Wood & J.D. Jacobson, *JChemPhys* **27**, 1207-08 (1957) (Preliminary Results from a Recalculation of the Monte Carlo Equation of State of Hard Spheres)
- L) IBM Pamphlets: a) "Introducing... the Computer"; b) "The Computer in Management Science"; c) "Simulation: Modelling Reality"; d) "Programming: Words That Move Machines"; and e) "Problem Solved by Linear Programming"
- M) UNIVAC, Division of Sperry Rand Corp, Defense Marketing, Univac Park, St Paul, Minn, 55118. Description booklets of UNIVAC Computers, obtained thru the courtesy of Mr. G.E. Lukinbeal, 2121 Wisconsin Ave, NW, Washington, DC, 20007:
- a) "UNIVAC CP-642-B Military Computer" (No year of publication). It is the first medium-scale, general-purpose, military computer to utilize a fast deposited magnetic *thin-film memory* (briefly described on p 2 of booklet) for control and index register storage (MO 7364)
- b) "UNIVAC 1206 Military Computer" (1962). It is a general-purpose stored-program machine capable of processing very rapidly a large quantity of complex data (PX 3634A). Its general electronic equipment must comply with Specification MIL-E-16400
- c) "UNIVAC 1218 Military Computer" (No year of publication). It is a medium-scale, general-purpose digital computer specifically designed to provide high reliability under adverse operational environments (PX3051)
- d) "UNIVAC 1219 Military Computer" (No year of publication). It is a faster version of the UNIVAC 1218 and is functionally compatible with it (PX3678)
- e) UNIVAC 1230 Military Computer (1965). It is a general-purpose, digital computer, which has been used successfully for missile guidance, fire control systems and other military purposes (PX3589)
- f) "UNIVAC 1824 Aerospace Computer" (No year of publication). It is a general-purpose, ruggedized machine designed for use where high reliability and high environmental tolerance are required and where very small size, weight and power consumption are premium considerations. The computer combines integrated semiconductor circuits and magnetic thin-film memory elements to form a very compact unit (PX3229C)
- g) "UNIVAC 1830A Computer" (1967). It is a miniaturized, highly maintainable, general-purpose, stored-program machine with performance characteristics satisfying the requirements of an airborne environment (PX4118D)
- h) "UNIVAC AN/UYK-7(V) Digital Computer" (April 1968). It is a general-purpose computer utilizing military qualified components and packaging (PX4758-A)
- i) "UNIVAC AN/UYK-8(V) Digital Computer" (June 1968). It is a general-purpose machine using microelectronic circuitry. It is designed specifically for Marine Corps applications (PX4907)
- N) J.M. Hammersley & D.C. Handscomb, "Monte Carlo Methods", part of Methuen's Monographs on Applied Probability and Statistics, " edited by M.S. Bartlett, Methuen & Co, Ltd, London (1964)
- O) D.L. Grobstein, Ed, "Data Processing System Office Information Report No 10. Index of Digital Computer Programs", Picatinny Arsenal, Dover, NJ (February 1967)
- P) A new digital program for the IBM 360 Computer, named STARFIT, has facilitated the extension of TIGER CODE calculations to the novel fluorine expts of the CHNOF type (PA ExpILabNews, No 4, p 3 (January 1969)

Condensed Explosives. See Vol 3 of Encycl, p C495-R

Condensed Explosives, Decomposition Thermal. See under Decomposition, Thermal of Explosives and Propellants in this Section

Condensed Explosives, Decomposition Thermal. Influence of Pressure and Temperature on. See under Decomposition Thermal of Explosives and Propellants. Influence of Pressure and Temperature in this Section

Condensed Explosives, Detonation (and Explosion) of. See Detonation (and Explosion) of Condensed Explosives

Condensed Phases, Testing. In the test described by Erikson (Ref), Lead Azide samples were exposed to the reflected shock region produced in an ordinary shock tube
Ref: T.A. Erikson, "Pure Environmental Shock Testing of Condensed Phases", 3rd-ONRSympDeton (1960), pp 24-41

Conductivity of the products of Explosion of Condensed High Explosives was discussed by A.A. Brush et al in ZhEkspTeoretFiz **32**, 1543 (1959)

Coned-, Hollow-, or Shaped-Charge Effect. See under DETONATION, MUNROE-NEUMANN EFFECT

Confined (or Cased) Charge. See Vol 2, p C150-L

Confinement of Deflagrating Explosives. See Vol 3, p D39 under Deflagrating Explosives and Deflagration

Confinement, Effect on the Detonation Waves in Solid Explosives. See Vol 3, p C498-R

Confinement Effects in Exploding Bridgewire Initiation of Detonation. Title of the paper by R.H.F. Stresau et al, in 4thONRSympDeton (1965), 449-60

Confinement Influence on Detonation Velocity. See under Detonation (and Explosion), Velocity

Constant β -Equation of State. See under "Detonation (and Explosion), Equations of State Used in"

Constant γ -Equation of State. See under "Detonation (and Explosion) Equations of State Used in"

Constant-Pressure Bomb and method for measuring burning velocities is described by W.A. Strauss & R. Edse, in 7thSympCombstn (1959), 377-85

Conformal Solution (CS) Theories. See under Detonation, Longuet-Higgins (LH) Theory

Contact Detonation Sensitivity Test. The sensitivities of expls to initiation by the deton of other expls have been determined by the use of one of the following methods: a) Minimum booster sensitivity test (Ref 1); b) Air-gap test (Refs 2, 3 & 4); or c) Barrier sensitivity test (Ref 5)

In the test proposed by Savitt et al (Ref 6), an explosive sample ("acceptor") is in direct contact with the "donor", which is a cylindrical charge of NGu (Nitroguanidine), enclosed in a cardboard tube with a large length-to-diameter ratio. When the donor is detonated at one face by means of a safety fuse and a Tetryl booster, the detonation propagates along the axis to the other face and then to acceptor. With this arrangement the pressure pulses which are generated in donor are transmitted directly to the acceptor without being attenuated by gaps or barriers. The response of the acceptor is detected by the deformation which is produced in a metal (such as Al) witness plate in contact with the outside face (See Fig)

As acceptors six expls were tested: TNB, TNT, Tetryl and experimental Explosives α , β and γ . As compositions of the exptl expls were not given in Ref 6, it is very difficult to draw meaningful conclusions. The tests determined the following properties:
A) Loading Density Effects. Acceptor samples 0.520 inches in diameter and 1 inch long, loaded at pressures 3400 to 32000 psi and confined in wood, were compared

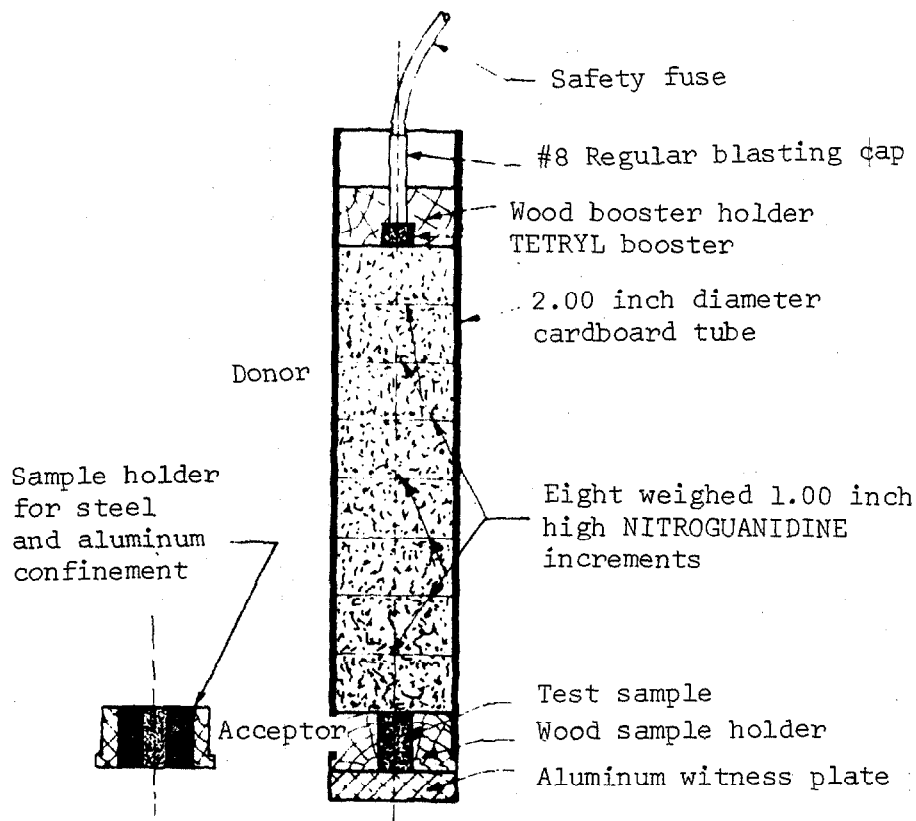

Fig 1 - Direct contact detonation sensitivity test system

B) Size Effects. Acceptor samples 1 inch long of diameters 0.254, 0.378 and 0.520 inches, loaded at 32000 psi were compared

C) Confinement Effects. Acceptor samples 1 inch long and 0.254 inch diam, loaded at 32000 psi and confined in aluminum, brass or steel, were compared

Refs: 1) L.C. Smith & F.H. Eyster, "Miscellaneous Sensitivity Tests", OSRD 5746 (1945)
 2) E.H. Eyster et al, "The Sensitivity of High Explosives to Pure Shocks", NOLM 10, 336 (1949)
 3) R.H. Stresau & L.B. Starr, "Some Studies of Propagation of Detonation Between Small Confined Explosive Charges", NOLM 10577 (1950)
 4) W.E. Dimmock, "A Small Scale Gap Sensitivity Test", NAVORD 2938 (1953)
 5) D. Price & I. Jaffee, "Large Scale Gap Test", ARSJour, May 1961
 6) J. Savitt et al, "Direct Contact Detonation Sensitivity", 4th ONRSympDeton (1965), pp 404-11

Contact Transmission of Detonation. Accdg to definition given by Dunkle (Ref 3): "It is the transmission of the process, as a detonation, directly from one medium to another". The process is described in detail by Paterson (Ref 1) and its resumé is given by Dunkle (Ref 2)

When a detonation wave S_1 initiated within a volume of explosive reaches its surface, a shock wave S_3 proceeds into the surrounding medium (or target). At the same time, a wave S_2 is reflected into the detonation products; this wave is either a shock or rarefaction depending on the physical properties of these products and of the target

Paterson (Ref 1, p 468) has shown that, although the system of waves arising from the surface of an explosive cartridge is complicated by the cylindrical form and finite dimensions of the cartridge, an approximation to the state of affairs at the end of the cartridge may be made by disregarding the lateral

effects and assuming that the detonation wave itself has proceeded so far from the zone of initiation that conditions are uniform behind the CJ (Chapman-Jouguet) plane. Even when this is not true, the theory should apply immediately after arrival of the detonation wave at the end of the cartridge. In view of the brief reaction time, the reaction-zone structure and the extreme conditions temporarily within it may be disregarded

For a transmitted shock wave advancing into any gas at an initial pressure p_0 of 1 atm, the RH (Rankine-Hugoniot) equation defines a functional relationship between pressure p_3 and particle velocity w_3 behind the wave S_3 , involving initial pressure p_0 , initial specific volume v_0 , and equations of state of the target medium. Similarly, the conditions behind the reflected wave S_2 and close to the product-target interface are expressible by means either of the shock wave equations or the Riemann adiabatic wave equations in terms of any one such variable and the conditions

ahead of S_2 . In particular, a relation exists between the pressure p_2 and flow velocity w_2 , involving the CJ values and the state equations for the reaction products. This may be referred to as the RHR (Rankine-Hugoniot-Riemann) (p,w)-relation for the reflected wave. However, continuity at the interface requires that $p_3=p_2$ and $w_3=w_2$. Two equations are then available to det p_2 & w_2 , so that the problem could be solved

In order to better illustrate the problem, Paterson plotted the p and w relationships for waves reflected into the detonation products $2H_2+O_2$ and $2CO+O_2$, as shown in Fig 1. Here the three ascending curves represent the shock waves in He, Air and CO_2 , which are regarded as ideal gases with constant specific heats, the initial pressure p_0 being 1 atm in each case. The two descending curves provide p_3-w_3 relations for waves reflected into the deton products. The criterion for shock reflection is that w_3 at the intersection is smaller than the $C-J$ value w_1 . The $C-J$ values

(p_1, w_1) for each mixture are indicated in Fig 1 by heavy points. Fig 1 also shows that $p_2 > p_1$ for the reflected waves in the products of the $2H_2+O_2$ mixt from targets of air and of CO_2 , but that the wave reflected from He is a rarefaction. In the products of the $2CO+O_2$ mixt, the waves reflected from all three targets are rarefactions

In solving an actual problem, Paterson advises to base the choice of shock or adiabatic wave equation for the products on an assumption regarding the nature of S_2 . If the conclusions contradict the assumption, the alternative equation is to be used. Although the general criterion for shock reflection is thus of a *posteriori* nature, it can be expressed in the form:

$$w_3(p_1) < w_1, \quad (\text{eq 1})$$

when, as in Fig 1, both intersecting curves are monotonic. For ideal gases with constant specific heat ratios γ (products), and γ_0 (target) this becomes, for the case of $p_1 \gg p_0$ approximately:

$$\rho_0 > 2\Delta \frac{\gamma+1}{\gamma_0+1} \quad (\text{eq 2})$$

where: Δ = density of the explosive gas before

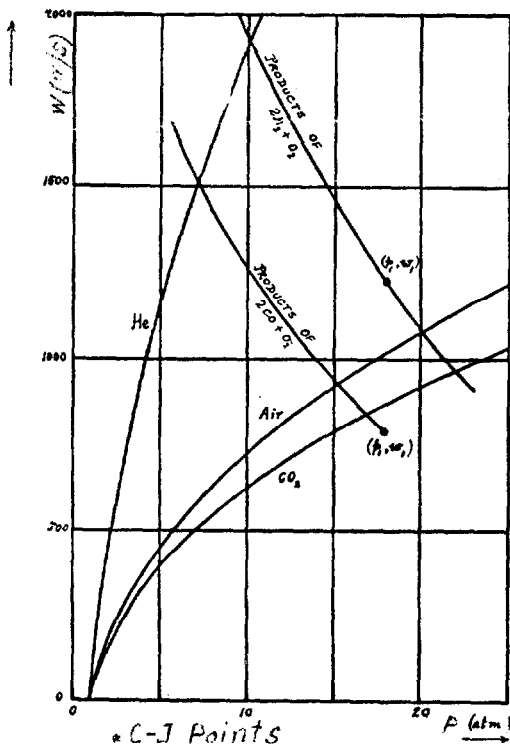

FIG 1 Reflexion of a gaseous detonation wave by an adjoining ideal gas

detonation and
 ρ_o = density of the target gas

Paterson extended his analysis (Ref 1, pp 469-71) to the case where the target material is itself an explosive capable of detonation. In this case, reaction in the target medium ("receptor" or "acceptor") must participate in the process of transmission; thus the conditions at the interface will be determined by the intersection of the p_2, w_2 curve in the products of the priming explosive (donor), not with the p_3, w_3 curve for nonreactive shocks in the acceptor, but with a curve passing thru the receptor CJ point

Using PETN of $\rho_o = 1.0 \text{ g/cc}$, as a receptor and as donor either NG or TNT based expls, Paterson determined values from the RH equations and drew the curves which are shown in

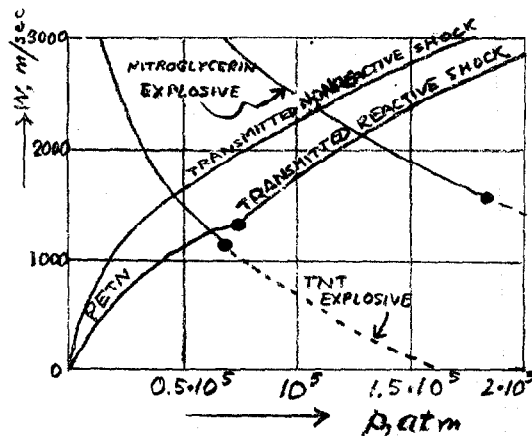

Fig 2 PETN at 1.0 g/cm³ primed by two explosives
 • = CJ-points

Fig 2. Here the "transmitted reactive shock" curve lies entirely below the curve for the "transmitted nonreactive shock". This means that the transmitted pressure p_3 and velocity D_3 are higher where reaction takes place, whereas w_3 is lower, so that the entry of reaction makes the receptor a more rigid target. The reactive p_3, w_3 curve is composite, with a gradient discontinuous at the CJ point. The lower ("underpriming") branch is determined by the locus of points of tangency, in the v, p plane, of the upward tangents from v_o, p_o to the family of R-H curves representing successive stages of completion

of the reaction. [These curves are shown on p 676 of the 5th Symp Combustn (1955) and in Ref 2, p 222, Fig 68]. As Paterson stated, this implies that the transmitted wave, though advancing with less than the stable velocity and therefore bound to accelerate, does so in a continuous manner and has a high degree of quasistability at the outset. The upper ("overpriming") branch of the reactive p_3, w_3 curve is detd by the upper branch of the equilibrium RH (v, p) curve itself (Ref 1, p 270 & Ref 2, p 295)

Paterson gives the following values for incident and transmitted waves for PETN primed by NG expl (I) and a TNT expl (II)

Table

| Primer | Incident Wave | | | Transmitted Reactive Wave | | |
|--------|-------------------|-------------------|-------------------|---------------------------|-------------------|-------------------|
| | p_1, atm | $w_1, \text{m/s}$ | $D_1, \text{m/s}$ | p_3, atm | $w_1, \text{m/s}$ | $D_1, \text{m/s}$ |
| I | 188000 | 1540 | 7900 | 130000 | 2130 | 6150 |
| II | 68000 | 1172 | 5060 | 64000 | 1230 | 5160 |

Results of Paterson's work show that the receptor (PETN) is considerably overprimed by the NG based expl, and slightly underprimed by the TNT based expl. The reflected wave is in each case a rarefaction, very weak with the TNT explosive. The condition for no reflected wave is that the primer C-J point lie on the receptor RH curve. The condition for a stable wave in the receptor is that the receptor CJ point lie on the primer RH curve; while the condition for exactly balanced priming is that the two CJ points coincide. The last condition is satisfied at every section in a single expl cartridge

Fig 2 shows also, for comparison, the transmitted RH curve for nonreactive waves. The properties of such waves transmitted by the same two primers are summarized by Paterson in the table, but this part is omitted by Dunkle and by us

Paterson also stated (Ref 1, p 471) that in his work the process of transmission has been reduced to its simplest terms. Later expl studies of initiation of detonation suggested, however, that, at least in gases, it

is more complicated, especially when the receptor is underprimed. It seems that part of the complication may arise from the necessity of separating gaseous primer and receptor by diaphragms; this difficulty is absent with solid explosives. Further exptl work in this direction is required

Refs: 1) S. Paterson, "Contact Transmission of Detonation", 4thSympCombstn (1953), 468-71 2) Dunkle's Syllabus (1957-1958), 45 & 294-95 3) Dunkle, private communications, Aug 1, 1968 4) C.G. Dunkle, private communication, Aug 12, 1968

"Contrasting Patterns in the Behavior of High Explosives". Title of the paper of Donna Price in 11thSympCombstn (1967) (Ref 17). Following is its resumé: High explosives can be divided into two groups accdg to the behavior of their granular pressed chges. These groups can be subdivided into pure expls & mixts of expls with a nonexpl fuel. The major division is made on the basis of either a *detonability limit curve* [charge diam (d) vs percent theoretical max density (100Δ)] or the pattern of deton vel vs loading-density curves at various fixed chge diameters. Group 1 materials (PETN, RDX, TNT & HBX-1) are those exhibiting more ideal behavior at lower porosities; Group 2 materials [AP (Amm Perchlorate), AP/fuel, Cheddites, Hydrazine Mononitrate, AN/fuel, NGu, DNT, DNPh, etc), are more ideal at high porosities

In group 1 critical diameter (d_c) increases with increasing critical density (ρ_c); consequently, for any fixed cylindrical charge diam, there is a critical loading density below which detonation will fail. Failure of detonation just below the critical diameter is attributed specifically to rarefactions entering the reaction zone and quenching the reaction. Therefore there is a close dependence betw the reaction-zone length and the critical diameter of a given explosive

The quantity 100Δ is equal to $100(\rho_1/\rho_v)$, where ρ_1 is loading density and ρ_v voidless density. The quantity $(1-\Delta)$ is the volume fraction of voids in the charge

Group 1 of HE's is characterized by the critical curve of Fig 1, for an unconfined

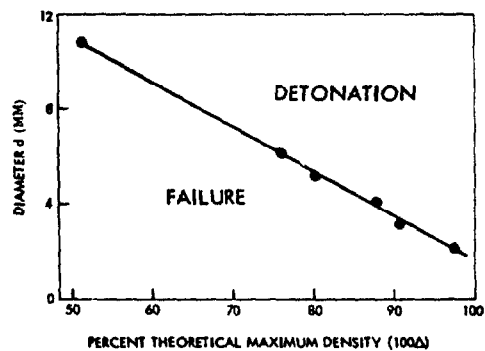

FIG 1 Detonability limits in the charge diameter-
porosity plane, Group 1. Example shown is TNT
(grain size 0.07 to 0.2 mm) data (Ref 2)

cylindrical charge of TNT, which is reproduced here. The curve may be considered as showing detonability limits in the charge diameter-*porosity* plane. The grain size of TNT was 0.07 to 0.2 mm

Group 2 is characterized by the limit curve Fig 2 for an unconfined cylindrical charge of Ammonium Perchlorate, average particle size 10 micron. Where value has been bracketted, (+) indicates detonation, and (-) indicates failure. Members of this group show a critical diameter increasing with increasing 100Δ or a critical density above which detonation fails. Failure behavior of this type is sometimes attributed exclusively to expls consisting of mixts of fuel and oxidizer, but it is also found in the case of some pure HE's. The curve may be considered as

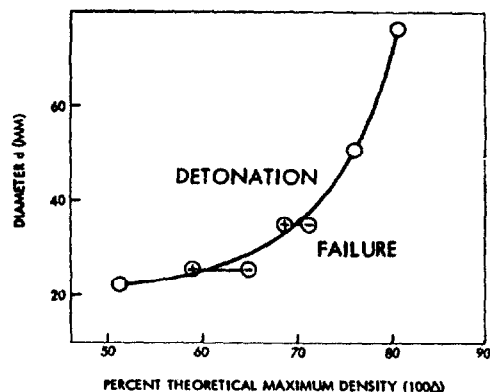

FIG 2 Detonability limits in the charge diameter-
porosity plane, Group 2. Example shown is AP
(average particle size 10 μ) data

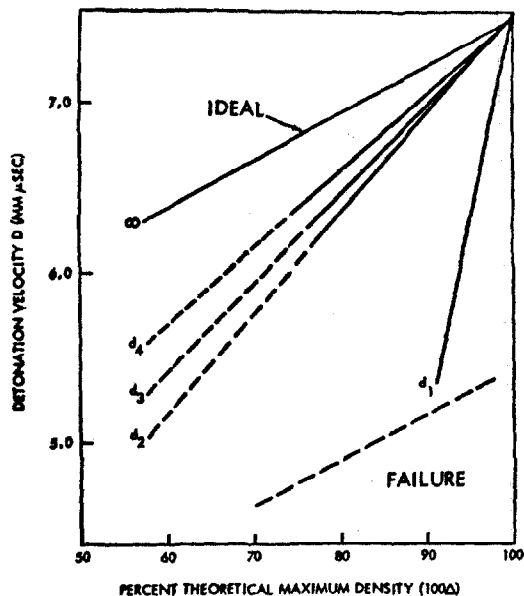

FIG 3 Pattern of detonation velocity vs porosity curves at various charge diameters, Group 1. Example shown is HBX-1 (RDX/TNT/A1/Wax, 40/38/17/5) data

showing detonability limits in the charge diameter-porosity plane

Dr Price also examined relations between (Δ) and deton velocity (D). They are presented in Fig 3 for group 1 and in Fig 4 for group 2

Fig 3 shows a representative of group 1, an unconfined cylindrical charge of HBX-1 (RDX/TNT/A1/Wax - 40/38/17/5). Its voidless density is 1.76 g/cc. The curves are for charge diameters d_1 , d_2 , d_3 & d_4 which are 6.4, 12.7, 25.4 & 50.8 mm, respectively. Solid lines are smoothed values from the experimental data which have been extrapolated to $\Delta=0.6$. The limit line for failure was estimated, as shown on p 694 of Ref 17. A pattern of the same type was previously obt'd by Stesik & Akimova (Ref 3) for TNT

Fig 4 shows an unconfined cylindrical charge of Ammonium Perchlorate, which represents group 2. Its particle size is 10 microns and the charge diameters examined d_1 , d_2 & d_3 were 34.9, 50.8 & 76.2 mm, respectively

In comparing behavior of groups 1 & 2 it was found that, at relatively large diameters and above the critical curve, expls of both groups exhibit a linear relationship betw the

measured deton vel(D) and the reciprocal charge diameter at a constant (Δ). Extrapolation of such experimental curves for a number of loading densities (ρ_1) led to the infinite diameter (d_∞) or ideal values (D_i) and a linear curve D_i vs Δ . It is in the region near the limit curve that the D vs Δ relations differ, which differences stem directly from the differences in critical curves. For group 1, behavior becomes more ideal as the loading density increases; at high Δ , a diam only slightly above the failure diam results in a D very close to D_i and, on further increase of diam, D becomes D_i . All the D vs Δ curves, each at a fixed diam, are linear and their pattern is that shown in Fig 3, where the chge diams d_1 to d_4 and the critical failure densities are highest for d_1 and lowest for d_4 . These linear curves are centered at the common D value for $\Delta=1.0$. They fan out with slopes which are a function of the reciprocal diam; the value of the slope increased linearly with d^{-1}

For group 2 materials (Fig 4), the behavior becomes more ideal as the loading density decreases. Hence, at $d_c < d < \infty$ in the detonation region, approximate linearity of D vs Δ would be expected until the limit line is approached. The curves seem centered on the ideal curve at some low Δ and fan out with slopes which decrease with the reciprocal diameter. Failure may be an abrupt termination or one show-

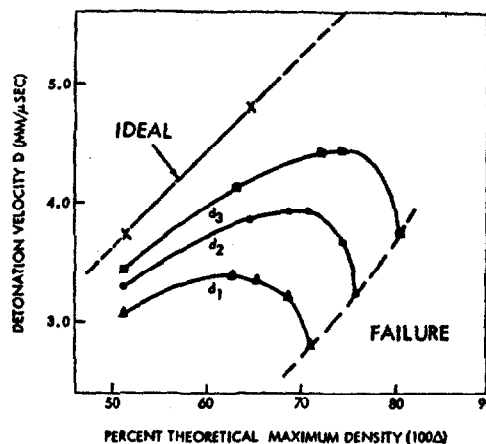

FIG 4 Pattern of detonation velocity vs porosity curves at various charge diameters, Group 2. Example shown is AP (average particle size 10 μ) data

ing a rapid drop in D just before the limit is reached (Ref 17, pp 694 & 695)

Dr Price mentions on p 694 that the work on relationship betw density and diameter was done in Russia (mostly on AN explosives) as early as 1945 (Ref 1). It was stated that "some pure explosives possess the capacity for a stable detonation only under the condition that their density does not exceed a certain *limiting value*". In later Rus works, such as of Blinov, Bobolev, etc, not only behavior of AN expls but also of DNT & DNPhenol were briefly described in the book of Andreev & Belyaev (Ref 4). Among the expls described, the 50/50-Amatol draws particular attention because its behavior seems to differ from those of group 1 or 2 (Ref 17, p 696)

Dr Price also mentions (Ref 17, p 696) her previous work on NGu (Nitroguanidine) (designated by Price as NQ) which consisted only of measuring output - power as shown by the ability to dent a steel plate - as a function of Δ , approaching Δ_c from above, but it demonstrated that d_c increases with increasing Δ

In the discussion entitled "Other Variables Affecting Detonability", Dr Price (Ref 17, p 696) reminds the reader that curves in Figs 1, 2, 3 & 4 are for unconfined charges and that *confinement* will shift the critical curves by changing the effective charge diameter

The critical curve can also be greatly shifted by the *grain-size effect*. The measured grain size is the particle size of the material before the chge is pressed, but its effect in shifting the curve is caused by the state of the grains in the compressed chge. Increasing the specific surface area by grinding the particles to a finer size shifts the limit line to a lower critical diameter for the same Δ for members of both groups. Figs 5a & 5b show shift of detonability limits caused by grinding the material. The Fig 5a is for group 1, as represented by TNT, grain sizes 0.07 to 0.2 mm for coarse and 0.01 to 0.05 mm for fine. The Fig 5b is for group 2, as represented by Dynamon (Rus expl: AN/Peat meal - 88/12). Its voidless density is 1.65 g/cc, but grain sizes are not given

Data in the literature seem to indicate

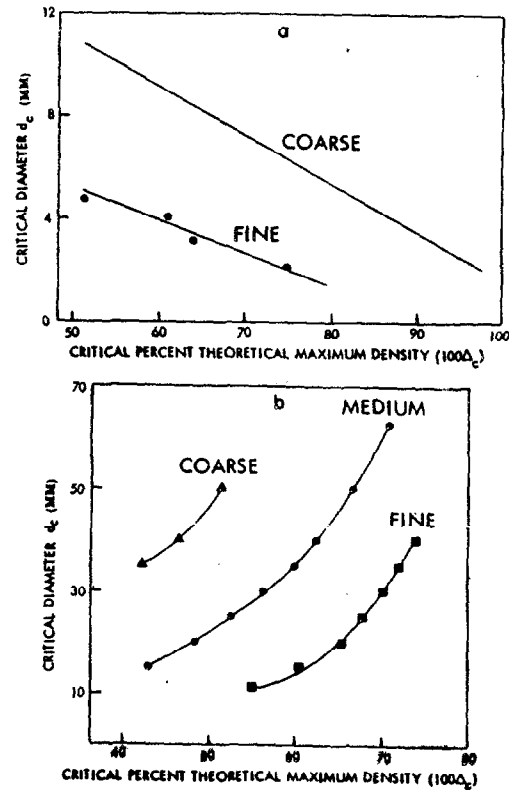

FIG 5 Shift of detonability limits caused by grinding the material. (a) Group 1. Example shown is TNT data (Ref 2). Grain sizes are 0.07 to 0.2 mm and 0.01 to 0.05 mm for coarse and fine, respectively. (b) Group 2. Example shown is dynamon (AN/peat meal, 88/12) data (Ref 1). The voidless density used is 1.65 g/cc

that if any grain size effect on D_i exists, it is quite small (Ref 17, p 697)

The *influence of temperature* on detonability limits was not determined in the laboratory of Dr Price, but only search of literature is reported. There are few data showing a limit curve in the diameter-temperature plane, but one set for NMe (Nitromethane) was reported by Campbell et al (Ref 4a) to exhibit the expected decrease in critical diameter with increase in temperature. However, NMe is a physically homogeneous liquid expl and its behavior differs, probably, from that of heterogeneous expls. Of the two references mentioned by Price, one (Ref 15) concerns granular charges of AN, while the other (Ref 16) deals with one propellant compn. In both cases, there seems to be a marked lowering of

d_c with increased temperature

Under the title "Shock-Sensitivity Behavior", Dr Price (Ref 17, p 697) describes attempts to answer the question of how the expl materials respond to hydrodynamic shock. By using the calibrated gap test previously described in Ref 14 as the "50% Gap Pressure", P_g was determined for several expls at various Δ . In order to measure the P_g required to cause a shock-to-detonation transition it was necessary to carry out gap tests under experimental conditions permitting detonability, ie, $d > d_c$. As the measured P_g is not an absolute value, but decreases with increasing effective charge diameter, the tests for all expls were conducted at a fixed charge diameter. It was assumed that the shock-sensitivity varies in some inverse manner with the measured minimum stimulus P_g required to initiate detonation. Results of tests represented by curves in Fig 6, showed that although P_g for all expls was increased with increase of Δ , the expls of group 2, as represented by Nitroguanidine (designated by us NGu and designated by Dr Price as NQ) showed steeper increase as indicated by the curves. The tests with other group 2 expls such as AN & AP expls gave curves (which are not included in Fig 6) with steeper slopes than those of group 1, but not as steep as for NGu

In the previous work of Dr Price (Ref 16), it was determined that increasing the test temperature decreased P_g for expls, presumably in both groups. Seely (Ref 6) found that increasing specific surface of granular materials of group 1 (Tetryl & PETN) by grinding, increased P_g , but reverse is true in voidless chgs. He also found that increasing specific surface by changing particle shape increased P_g of group 2 materials

In the "Discussion" given on pp 698-700, there is a summary of known works on behavior of groups 1 & 2 explosives. Four tables are included: Table I - "Steady Propagation behavior with increase in variable; Table II - "Effect on P_g of increase in variable; Table III - "Synopsis of typical group behavior"; and Table IV - "Comparison of detonation parameters for typical members

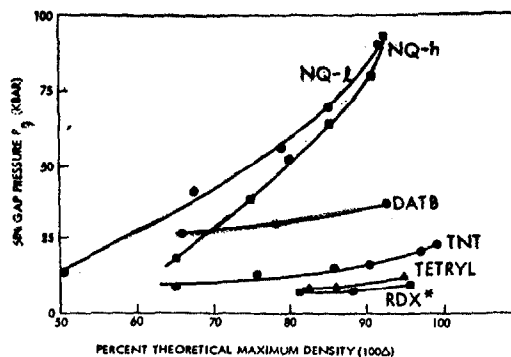

Fig 6 Effect of Δ on shock sensitivity of various explosives. NQ-l is low-bulk-density nitroguanidine with hollow-needle crystals of about 5μ diam \times $60-65 \mu$ long. NQ-h is the high-bulk-density material made up of solid particles of about $60-65 \mu$ diam. DATB, TNT, and Tetryl are, respectively, diaminotrinitrobenzene, trinitrotoluene and trinitrophenylmethyl nitramine. RDX* is cyclotrimethylenetrinitramine which contains 2.5% lubricant. Measurements were carried out with a standardized test (Ref 16) in which a 3.65-cm-diam test explosive confined in 0.55-cm-thick steel is the acceptor and polymethyl methacrylate is the gap material
NQ = NGu (Nitroguanidine)

of each group". The parameters listed are: crystal density, g/cc; detonation velocity, D in mm/sec; pressure, kbar; temperature, $^{\circ}$ K; and chemical energy, cal/g. Values of Table IV are taken from Refs 5 & 13

In conclusion Dr Price stated that her "paper posed problems rather than solved them" and that "much more additional work is required". (See also "Critical Density and Critical Diameter")
Refs: 1) A.F. Belyaev & A.E. Belyaeva, DoklAkadN 50, 295 (1945) (Translated by US Joint Publication Research Service JPRS:7524) 2) V.K. Bobolev, DoklAkadN 57, 789 (1947) (Translation JPRS:4026) 3) L.N. Stesik & L.N. Akimova, ZhFizKhim 33, 148 (1959) 4) K.K. Andreev & A.F. Belyaev, "Teoriya Vzryvchatykh Veshchestv", Oborongiz, Moscow (1960) (Available at PicArnsn Library) 4a) A.W. Campbell et al, Phys Fluids 4, 498 (1961) 5) D. Price & H. Hurwitz, "RUBY Code Calculations of Detonation Properties, C-H-N-O Systems", US Naval Ordnance Report, NOLTR 63-216 (1963) 6) L.B. Seely, "A Proposed Mechanism for Shock Initiation of Low Density Granular Explosives", Proc

4th Electric Initiator Symp at Franklin Institute, Philadelphia, Pa, 1963, Paper 27 of Rept EIS-A2353 6a) K.K. Andreev et al, "Teoriya Vzrychatykh Veshchestv; Sbornik Statey" (Theory of Explosive Substances; Collection of Papers); Oborongiz, Moscow (1963); listed in CA 59, 12585 (1963). Engl transl by the Foreign Technology Div, Air Force Systems Command, Wright-Patterson AFB (AD 605 706)

7) W.E. Gordon, "Detonation Limits in Composite Explosives", 10th Symp Combustn (1965), 833-38 8) A.N. Dremin & V.S. Trofimov, "On the Nature of Critical Diameter", Ibid, 839-43 9) V.M. Boyle et al, "Pressure Measurements During Shock Initiation of Composition B", Ibid, 855-61 10) B.G. Craig, "Measurement of the Detonation-Front Structure in Condensed-Phase Explosives", Ibid, 863-67 11) W.E. Gordon, "Detonation Limits in Condensed Explosives", 4th ONR Symp Deton (1965), 179-97 12) M.C. Chick, "The Effect of Interstitial Gas on the Shock Sensitivity of Low Explosive Compacts", Ibid, 349-58 (1965) 13) Marjorie W. Evans et al, "Shock Initiation of Low-Density Pressing of Ammonium Perchlorate", Ibid, 359-71 14) Donna Price & T.P. Liddiard Jr, "The Small Scale Gap Test: Calibration and Comparison with the Large Scale Gap Test", **NOLTR 66-87** (1966) 15) R.W. VanDolah et al, "Explosion Hazards of Ammonium Nitrate Under Fire Exposure", USBur Mines Report of Investigation **RI 6773** (1966) 16) Donna Price et al, "Shock Sensitivity of Solid Explosives and Propellants", paper presented to be published in Proc 36th Congrès International de Chimie Industrielles, Belgium, Sept 1966 17) Donna Price, "Contrasting Patterns in the Behavior of High Explosives", 11th Symp Combustn (1967), 693-702

Note: Our Refs 4, 8, 9, 10, 11 & 12 were not included in D. Price paper

18) Donna Price et al, "Explosive Behavior of Ammonium Perchlorate", Combustion & Flame 11, 415-25 (Oct 1967)

Cook's Geometrical Model Theory. See Detonation, Geometrical Model Theory of Cook

Cord Detonating or Cordeau. See Vol 3, p C529-R and also Detonating Cords or Detona-

ting Fuses in Vol 3, p D103-R. The Detonating Cord of Bofors, known as Bonocord is described in Vol 2, p B218 and its testing in Vol 3, p D103-L

Cordite Explosion Zone, Chemical Kinetics of. It was discussed by J.G. Sotter in 10th Symp Combustn (1965), 1405-11

Corner Equation of State. See Vol 3, p C542-L. Its modification by Murgai is given in this write-up under Detonation (and Explosion), Equations of State

Correlation of Thermal Quantities with Explosive Properties. Title of A.D. Little, Inc, Report, Contract W-19-020-ORD-6436, Part II (1947)

Corresponding States, Law of. If any two (or more) substances are at the same *reduced pressure* (See under "Introduction" to Equations of State), $\pi = p_r$, or the same fraction or multiple of their respective *critical pressures*, p_c , and are at equal *reduced temperatures*, $\theta = T_r$, then their *reduced volumes*, $\phi = V_r$, should be equal. These substances are said to be at *corresponding states*, and the statement is the *law (or principle) of corresponding states* (Ref 3, p 183 & Ref 2, p 280)

For example, oxygen has critical temp $T_c = 154^\circ \text{K}$ & chlorine 419°K and their respective critical pressures, p_c , are 50 & 76 atm. If observed temps, T , are 123° & 335° , respectively, $T_r = 123/154 = 0.8$ for O_2 and $T_r = 335/419 = 0.8$ for Cl_2 . This means that at these temps, corresponding pressures should result in corresponding densities (Ref 2, p 280)

Hirschfelder et al (Ref 4, p 235), gave a more comprehensive description of the law, calling it the *principle of corresponding states*

The principle, in the form originally stated by van der Waals ca 1881 at the time of development of his equations of state (See under "Introduction" to Equations of State), is based on the reduction of the variables using the *critical constants* (qv). This formulation is the basis of the "generalized charts for the compressibility and thermody-

dynamic properties of dense gases and liquids", compiled by O.A. Hougen & K.M. Watson and reproduced in Ref 4, pp 239-44

A modified law of corresponding states suitable for real gases was proposed in 1946 by Gouq-Jen Su of Univ of Peiping, China (Ref 1). A term called the "ideal critical volume" was defined and the ratio of volume over the ideal critical volume was called the "ideal reduced volume". It was shown that for 17 gases within the temperature and pressure ranges studied, the over-all deviation was only 1%. The value of the critical ratio was not a restriction or a criterion for the applicability of the modified law

In another form of the principle, the variables are reduced by means of molecular constants and additional parameters are introduced

Under the heading "The empirical principle of corresponding states", Hirschfelder et al (Ref 4, p 235), stated:

"The *critical point* is defined as that point for which both $(\partial p/\partial V)_T$ and $(\partial^2 p/\partial^2 V^2)_T$ are zero; the values of the pressure, volume, and temperature at this point - the *critical constants* - are designated by $p_c, V_c,$ and $T_c,$ respectively.

These constants are used to define a set of *reduced variables*:

$$p_r = p/p_c, \quad V_r = V/V_c \quad \text{and} \quad T_r = T/T_c \quad (\text{Eq 4.1-1})$$

The *empirical principle of corresponding states* may then be stated in the form: "All substances obey the same equation of state in terms of the reduced variables"

In general, the state of a system may be described by any two of the three variables: $p, V,$ and $T.$ Thus, accdg to the "principle of corresponding states", any dimensionless group is a universal function of any two of the three reduced variables. In particular the *compressibility factor*, pV/RT of van der Waals' equation of state, can be written as a universal function of the reduced volume and temperature:

$$pV/RT = F(V_r, T_r) \quad (\text{Eq 4.1-2})$$

For actual systems, it is usually more con-

venient to use reduced pressure and temperature:

$$pV/RT = z(p_r, T_r) \quad (\text{Eq 4.1-3})$$

Both F and z are *universal functions*, identical for all substances

In terms of reduced parameters the *critical point* occurs at $V_r=1$ and $T_r=1.$ Thus from eq 4.1-2 we can note that at critical point the value of "compressibility factor", also known as the *universal constant*, is:

$$p_c V_c / RT_c = F(1,1) \quad (\text{Eq 4.1-4})$$

The compressibility factor pV/RT at the critical point for many gases and hydrocarbon liquids is shown in Table 4.1-1, p 237 of Ref 4

From the principle of corresponding states, Hirschfelder et al (Ref 4, p 236), derived another equation:

$$p_r = (RT_c/p_c V_c)(T_r/V_r)F(V_r, T_r) \quad (\text{Eq 4.1-5})$$

and since the critical ratio $(p_c V_c / RT_c)$ is a universal number, it follows that p_r is a universal function of V_r and $T_r:$

$$p_r = G(V_r, T_r) \quad (\text{Eq 4.1-6})$$

The principle of corresponding states provides a convenient and rough means for detg the properties of a dense gas or a liquid. The only info required is the value of two of the critical constants for the substance under consideration. As the critical volume is very difficult to measure, even approximately, it is more convenient to use the expression in terms of p_r, T_r (Eq 4.1-3) rather than in terms of V_r, T_r (Eq 4.1-2). The values of the critical constants may in turn be estimated from more readily available data, such as bp, mp, etc. For example, if bp of a substance is $T_b,$ its critical temp $T_c,$ is approximately $3/2 T_b$ and if mp is T_m its T_c is approx $5/2 T_m$

For more precise calcs the Hougen & Watson charts, already mentioned, may be used. In these charts compressibility and thermodynamic properties of gases and liquids are plotted as functions of the reduced pressure $p_r = p/p_c,$ for different values of the reduced temperature $T_r = T/T_c$ (Ref 4, pp 239-43)
Refs: 1) Gouq-Jen Su, IEC **38**, 803-06 (1946) (Modified law of corresponding states for real gases) (17 refs) 2) S.J. Starling & A.J. Woodall, "Physics", Longmans-Green, Lon-

don(1950) 3) Van Nostrands' Dict (1953)
4) J.O. Hirschfelder, C.F. Curtis & R.B. Bird, "Molecular Theory of Gases and Liquids", Wiley, NY (1954)

Cottrell-Paterson Equation of State. See Vol 3, p C547-R and item f under Detonation (and Explosion), Equations of State

"Course of the Reaction in a Detonation Wave of a Mixed High Explosive". Engl translation by M.E. Backman of the Rus paper by A.Ya. Apin et al in ZhPrikMekhan i TekhnFiz 1963, No 5, 115-17; NAVWEPS Rept 9045, NOTS TechPaper 4050, China Lake, Calif (1966)

Covolume. See Vol 3 of Encycl p C550-R and under Detonation (and Explosion), Equations of State, in this Volume. See also the following:

Addnl Refs: A) Cook (1958), 64-5, 265 & 287 (Covolume); 63-5 (Covolume equation of state)
B) Dunkle's Syllabus (1957-1958), 181-84
C) Baum, Stanyukovich & Shekhter (1959), 126 & 243

Covolume and the Condition of Gases of Decomposition in the Detonation Zone of Brisant Explosives. The Engl translation of Ger paper: "Ueber das Covolumen und den Zustand der Schwaden in der Detonationszone brisanter Sprengstoffe" by J.F. Roth, SS 34, 193-97 (1939) & CA 33, 8406 (1939)

Four expls: PETN, Tetryl, Picric Acid & TNT were investigated and results were discussed [See also A. Schmidt, SS 27, 145 (1932); 30, 364 (1935) and 31, 8, 13 & 40 (1936)]

Covolume Theory as Applied to Propellants in Interior Ballistics was discussed by Corner in Ballistics (1950), pp 102-14

Coyote Blasting. See Vol 3, p C551-L

Crater from Explosion and Cratering Effect. See Vol 3, p C553-L and Vol 2, p B182-R under Blast Effects in Earth. Also in Vol 3, p C553-L and in Robinson (1944), pp 40-44

Cratering Charge or Cratering Explosive. See Vol 3, p C553-R

Cratering Effect. See Vol 3, C553-L and Tests on p C554

Criterion of Explosiveness. The criterion of explosiveness is *energy release*. The atoms in the molecules of an explosive can rearrange in response to *breaking stress* (Described on pD 227-L) to form new combinations having greater stability. An expl has potential energy exactly like that of a boulder lodged on the slope of a mountain. It requires some energy to dislodge it, but on being dislodged releases far more energy than was applied. There is thus an inherent instability. The molecules are in a condition of strain which on release can transmit a "breaking stress" to others. A destructive stress may be applied to any material, but will not be transmitted appreciably in materials which do not release energy in sufficient quantity or intensity to maintain it. Explosives, on the other hand, are distinguished by sensitivity to various influences, such as thermal, mechanical and electrical

Accdg to Dunkle, "energy release" is necessary but not sufficient for "explosiveness" (See also under "Decomposition of Explosives and Propellants", in this Volume)
Ref: Dunkle's Syllabus (1957-1958), p 137

Critical Charge Density-Detonation Velocity Relationship. See under Detonation-Velocity Charge Density Relationship

Critical Charge Diameter-Detonation Velocity Relationship. See under Detonation Velocity-Charge Diameter Relationship

Critical Constants of Equations of State, p_c , V_c & T_c . See under "Corresponding States"

Critical Constants of Liquid Explosives. See Vol 3 of Encycl, p C560-R

Critical Density-Detonation Velocity Relationship. See under Detonation Velocity-Charge Density Relationship

Critical Detonation Velocity and Limiting Velocity. See Detonation Velocity, Critical and Limiting

Critical Diameter (Failure Diameter). A brief discussion is given in Vol 3 of Encycl, pp C560-R & C561-L

Critical Diameter and Limiting Diameter-Detonation Velocity Relationships. See Detonation Velocity-Critical and Limiting Diameter Relationships

Critical Diameter of Liquid Explosives. A brief description of work done by Khariton (Ref 1), Jones (Ref 3), Eyring (Ref 3), Campbell (Ref 4), Shchelkin (Ref 5), Garn (Ref 7), Iluykhin et al (Ref 8), Belyaev et al (Ref 9), Evans (Ref 11) as well as the work of Dremine et al (Refs 6, 10, 12, 13, 14 & 15) was given by Dremine & Trofimov (Ref 16)

It has been ascertained by Shchelkin and Dremine et al, that with liquid explosives the detonation wave is not smooth and that oblique nonstationary waves (inhomogeneities) arising as a result of instability of the ignition plane of the deton wave travel over its front. At the sites of the oblique-wave collisions with each other and with rigid envelope, the temperature is higher than that behind the smooth shock front moving at deton velocity. Consequently, the reaction of a liq expl in a real deton wave will be initiated first at collision sites. A reaction occurring at an individual site will generate new inhomogeneities, the collision of which will result in other individual reactions in the next layer of the explosive. When there is no rigid envelope, the periphery inhomogeneities that collided before with the envelope cease to initiate the reaction, no new inhomogeneities appear at the boundary, and those formed adjacently meet no partners to collide with. This results in a successive diminishing of the detonation front. A process of this kind may stop detonation, provided no new detonation front develops within the compressed explosive behind the shock wave left by the terminated reaction. The new detonation wave would travel over the com-

pressed explosive, overcoming the attenuating deton front, and restoring detonation throuth the charge section. This process is repeated in cycles. *The critical-charge diameter is that at which the attenuating detonation front will not be restored by the wave traveling over the compressed explosive. This would occur in the event the old detonation front succeeded in disappearing and the rarefied waves from the charge periphery rarefied the compressed explosive before a new detonation wave is initiated*

In transition of detonation from a rigid-wall tube into a larger volume, the detonation will cease if the tube is of smaller diameter than the critical one for a weakly confined or unconfined expl. Whereas, when the diam is greater than the critical one, an outward-going deton wave will arise in a certain time period after transition, and the explosive will detonate in the larger volume

Fig presented here is a copy of Fig 1 of Ref 16, p 840. It is a sketch of a photographic record (made by means of a high-speed smear camera from the butt end of the tube) of a detonation passing from a narrow tube to a wider one. The diams of tubes are larger than critical. Dark zones correspond

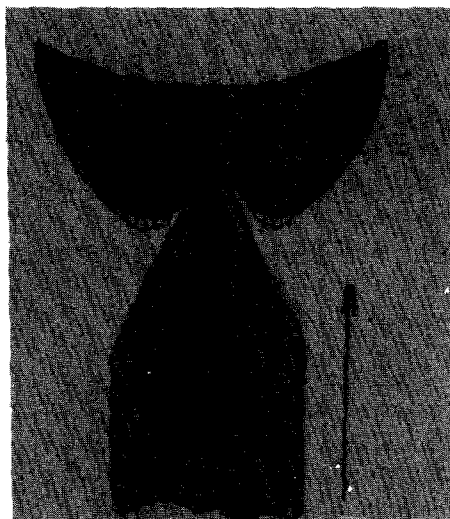

Transition of Detonation From a Narrow Tube to a Wider Tube

to luminiscence of the detonation front, light zones to absence of reaction, and shading represents weak luminiscence sometimes observed in the detonation wave traveling over a shock-compressed explosive (preluminiscence). Arrow indicates the direction of time axis. The outward-going deton wave arises initially at some distance from the charge axis and travels both toward and away from it. In moving toward the axis, it overcomes the reaction-quenching wave and interrupts the quenching of detonation

Further discussion in Ref 16, pp 840-41 leads to the development of formula for determination of critical diameter. Using this formula, critical diameters were calculated for NMe (Nitromethane) at 20° and for liquid TNT at 82°. They are 14.3 and 62 mm, respectively, and close to experimental values of 18 and 68 mm

Critical diameters of the following liquid expls are listed by Andreev & Belyaev (Ref 9a, p 198): 87.5/12.5 - Tetranitromethane/Benzene <0.1 mm; 72/28 - Nitric Acid/Benzene 0.5; NG 2.0; 70/30 - Nitric Acid (70% strength)/Methylol >10; Liquid TNT at 81° 62; Liquid TNT at 240° 6.0

Refs: 1) Yu.B. Khariton, "O Detonatsionnoy Spssobnosti Vzryvchatykh Veshchestv" in "Voprossy Teorii Vzryvchatykh Veshchestv", IzdAkadNauk, Moscow (1947) 2) H. Jones, PrRoySoc **189A**, 415 (1947) 3) H. Eyring et al, ChemRevs **45**, 69 (1949) 4) A.W. Campbell et al, JApplPhys **27**, 963 (1956) 5) K.I. Shchelkin, ZhEksperim i TeoretFiz **36**, 600 (1959) 6) A.N. Dremin & P.F. Pokhil, DoklAkadN **127**, 1245 (1959) & **128**, 989 (1959) 7) W.B. Garn, JPhysChem **30**, 819 (1959) & **32**, 653 (1960) 8) V.S. Ilyukhin et al, DoklAkadN **131**, 793 (1960) 9) A.F. Belyaev & R.Kh. Kurbangalina, FizKhim **34**, 3 (1960) 9a) Andreev & Belyaev (1960), 198 10) A.N. Dremin et al, DoklAkadN **133**, 1372 (1960) & **139**, 137 (1961) 11) M.W. Evans, JChemPhys **36**, 193 (1962) 12) A.N. Dremin, DoklAkadN **147**, 870-73 (1962); CA **58**, 7779-80 (1963) 13) A.N. Dremin et al, Combstn Flame **7**, 153 (1963) 14) E.N. Buranova et al, Prikl-Mekh i TekhFiz No 4, 101 (1963) 15) A.N. Dremin et al, ZhPriklMekhan i TekhFiz, **1963**(1), 130; Ibid, **1964**(1), 126-31; CA **61**, 1698 (1964) 16) A.N. Dremin & V.S. Trofimov,

"On the Nature of Critical Diameters" 10th-SympCombstn (1965), 839-43

Critical Diameter of Solid Explosives. This subject is discussed in the books of Baum et al (Ref 1) and of Andreev & Belyaev (Ref 2)

Combining information from both books, we compiled the following table:

Critical Diameters of Some Solid Explosives in Powdery Form

| Explosive | Density, g/cc | Particle Size, mm | Critical Diameter, mm |
|----------------------|---------------|-------------------|-----------------------|
| Lead Azide | 0.9-1.0 | 0.05 -0.2 | 0.01- 0.02 |
| PETN(TEN) | 1.0 | 0.025-0.05 | 0.7 - 0.9 |
| PETN | 1.0 | 0.05 -0.1 | 1.0 |
| PETN | 1.0 | ca 0.25 | 2.1 - 2.2 |
| RDX(Geksogen) | 1.0 | 0.025-0.15 | 1.0 - 1.15 |
| RDX | 1.0 | ca 0.2 | 1.5 |
| Lead Picrate | 0.75 | 0.01 -0.05 | 1.45- 1.53 |
| Lead Picrate | 1.0 | ca 0.2 | 2-3 |
| Picric Acid | 0.8 | 0.01 -0.05 | 2.08- 2.28 |
| Picric Acid | 0.95 | 0.1 -0.75 | 8.9 - 9.25 |
| K Picrate | 0.75 | 0.04 -0.15 | 5.5 - 6.0 |
| TNT(Trotyl) | 0.85 | 0.01 -0.05 | 4.5 - 5.4 |
| TNT | 0.85 | 0.07 -0.2 | 10.5 -11.2 |
| 79/21-AN/TNT | 0.9-1.0 | 0.05 -0.2 | 10-12 |
| 90/10-AN/TNT | 0.9-1.0 | 0.05 -0.2 | 15 |
| 80/20-AN/Al | 0.9-1.0 | 0.05 -0.2 | 12 |
| AN(Ammonium Nitrate) | 0.9-1.0 | 0.05 -0.2 | 100 |

The above table shows that critical diameter increases with increase of density and particle size. Critical diameter of AN/TNT mixture increases with increase of AN content

It has also been shown that confinement decreases the critical diameter of a charge
Refs: 1) Baum, Stanyukovich & Shekhter (1959), 284-86 2) Andreev & Belyaev (1960), 198-201 3) I. Jaffe "A Method for the Determination of the Critical Diameters of Explosives", NavWepsRept **7360** (1960), USNavalOrdnLab, White Oak, Silver Spring, Md

Critical Energy of Impact (or Shock) in Detonation (or Explosion). This term signifies the minimum available energy of the falling hammer to produce explosions in impact sensitivity tests. It is designated as A_c and expressed

as cal/cm^2 . The following values of A_c which were computed for various expls by Cook et al, from data obtd with Picatinny Arsenal Apparatus using a 2 kg weight: Amatol (50/50) 0.72 cal/cm^2 ; Composition B 0.77; Composition C-4 1.2, Diazodinitrophenol 0.12; EDNA (Haleite) 0.6; Lead Azide 0.29; Mercuric Fulminate 0.12; NG 0.6; Pentolite (50/50) 0.77; PETN 0.35; RDX 0.47; Tetracene 0.12; Tetryl 0.47; TNT (loose) 0.9 & Torpex 0.48 (Ref 2)

Kistiakowsky (Ref 1) suggested that for the success of detonation by impact two sets of conditions must be met: a) A hot spot, as defined by Bowden, must be first produced and b) The initial deflagration must be given the opportunity to develop and to produce a shock wave within the minute charge and the short time defined by the usual conditions of explns by impact (See also Ref 3) Refs: 1) G.B. Kistiakowsky, p 565 in the 6th Symp Combustn (1957) 2) Cook (1958), 332 3) Dunkle's Syllabus (1957-1958), 159 4) Baum, Stanyukovich & Shekhter (1959), 32 & 37 (Critical energy of shock)

Critical Isotherm. See under "Critical Point"

Critical Length of Propagation of Detonation.

In examining the process of initiation of expls, it is of importance to determine not only the critical density, ρ_c , and critical diameter, d_c , of a detonator (or booster), but also its critical length, l_c , which is the shortest length required for steady state detonation. It is known that if the initial velocity of shock wave of an initiator is equal to or lower than the velocity of sound, C_0 , in the charge to be initiated, no detonation can take place even with a large initiator. This means that the critical detonation velocity of an initiator, D_c , must be higher than a certain value which is different for each explosive to be initiated. Another requirement for successful detonation is that pressure at the front of a detonation wave produced by initiator at the expense of chemical energy, must be maintained at a certain minimum level

Baum et al (Ref 1, p 278) examined initiation of cylindrical charges of HE's by

various initiators. If the chge of an expl such as TNT, PETN, or RDX were pressed, it could be initiated by a No 8 detonator. If the charge were cast (such as TNT), a booster was required in addition to a detonator. By initiating a cast cylinder of TNT, 10 cm long of density $\rho_0 = 1.60 \text{ g/cc}$ placed horizontally on a thin brass plate (which rests on a thick steel plate) (See Fig 1), it was possible to determine not only the velocity of detonation by photographic or other methods, but also the length of propagation of detonation. If the detonation wave propagated the full length of the chge, the brass plate had a burnt mark at full length of the chge. If the deton wave propagated only part of the length, the mark on the brass plate was shorter. By varying strengths of detonators, various lengths of propagation could be obtd



Fig 1 Cartridge for Determination of Critical Length
1. Explosive Charge; 2. Electric Detonator; 3. Thin Brass Plate; 4. Thick Steel Plate; and 5. Base

If the detonator were of sufficient strength to cause full length detonation for chge diams 10-20 mm of cast TNT, the critical diameter, d_c , at a given density, ρ_0 , could be determined by using the same method as above; by changing the diams until fading took place

If it were desired to determine critical density, ρ_c , by this method, charges of the same diameter, but of various densities, were detonated until a minimum density at which the detonation wave would propagate thru full length of chge was reached. This gave

the critical density at a given diameter and the diameter was critical at the critical density. Now, if another density were taken and diameter varied, a critical diameter for that density could be obtained

The length of consumed column can also be determined photographically. The velocity of detonation can be determined by one of the methods described in Vol 3 of Encycl under CHRONOGRAPHS, pp C311-C317, or by Drum Camera Methods, described in Vol 2 under CAMERAS, p C14-L

Baum et al (Ref 1, p 274) also examined initiation of TNT by detonators of various strengths. For this they brought a detonator in direct contact with a charge of TNT as shown in Fig 2. If detonator contained Amatol (TNT 90% & AN 10%) of diam slightly above critical and its critical deton vel was ca 1600 m/sec, no full length deton of TNT was possible because velocity of sound, C_o , in TNT at $\rho_o=1.60$ is higher, namely ca 1900 m/sec. In this case the critical detonation velocity, D_c , of initiator diminished until fading took place. The relationship l - D is shown by curve 1 of Fig 2

In order to achieve complete initiation of the above chge of TNT, it was necessary to

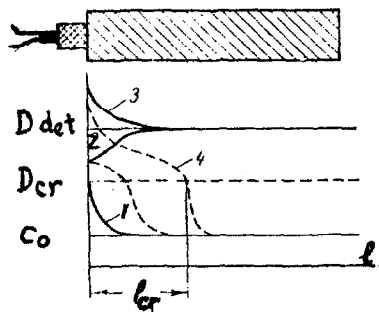

Fig 2 Development of Explosion in a Charge of TNT

use an initiator with a booster expl possessing a higher deton velocity than chge to be detonated (in this case TNT). For a booster in direct contact with TNT as shown in Fig 2, the maximum effect was obtained when diam of booster was equal to diam of TNT chge. If diam of booster were smaller, the same effect could be obtained

by increasing its length but only to a certain value, which is known in Rus literature as the *effective length*, l_{ef} . Further increase of l at fixed density, diameter, etc did not increase effectiveness of initiation

If the relation l_{ef}/l_r (where l_r is the width of the reaction zone) of an initiating expl is small, the process starting with a low detonation velocity eventually developed into normal detonation with velocity D_{det} . This is represented by curve 2 of Fig 2

If deton vel of an initiator (of optional length and of the same diam as the main charge), were higher than deton vel of the main chge, the deton proceeded for a length of a few cms in the main chge at vel higher than its normal value, D_{det} . This is shown by curve 3 of Fig 2

Curve 4 of Fig 2 shows the case of deton which fades after its vel reaches the critical value D_{cr}

Following are three curves (Figs 3, 4 & 5) [taken from the book of Baum et al (Ref 1, pp 279-80)] which show dependence of l_{cr} from various factors, as determined by the method illustrated in Fig 1

In Fig 3 is shown the dependence of critical length (l_{cr}) of detonators (diam $d=24.5$ mm charged with Tetryl of $\rho_o=1.6$) from the length of column. As can be seen, 50 mm is the optimal length

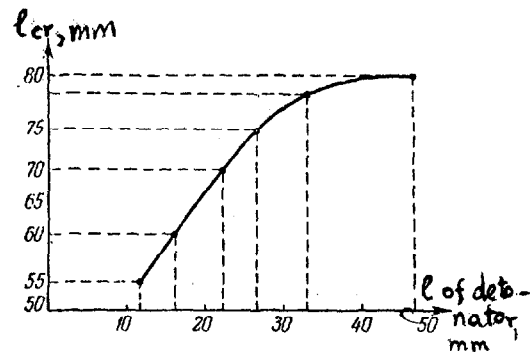

Fig 3 Critical Length (l_{cr}) vs Length of Detonator (l)

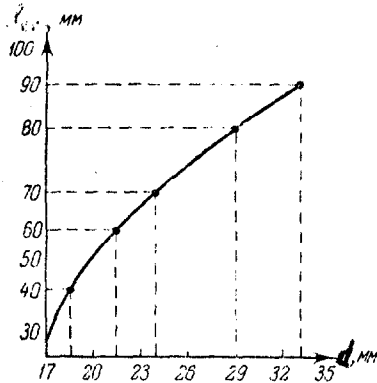

Fig 4 Critical Length (l_{cr}) vs Diameter of Detonator (d)

Fig 4 shows dependence of critical length of Tetryl detonators from their diameters. At diam of ca 33.5 mm the critical length is 90 mm

Fig 5 shows dependence of critical diam of Tetryl detonators from relationship between diam of deton and diam of main chge of TNT. The upper straight line deals with a detonator placed inside the main chge. This increases initiating ability of the detonator

Andreev & Belyaev (Ref 2) did not discuss the influence of critical length on diameter and length of detonators

Refs: 1) Baum, Stanyukovich & Shekhter (1959), 277-79 2) Andreev & Belyaev (1960) - not found

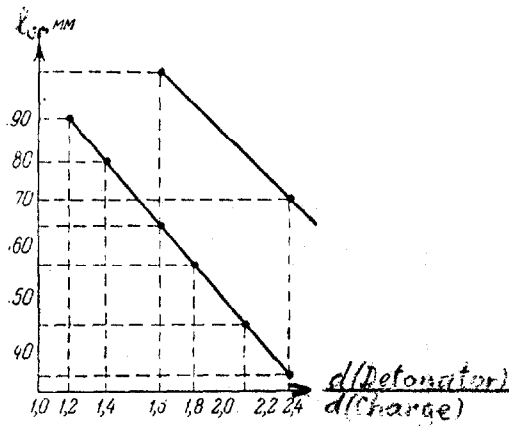

Fig 5 Critical Length (l_{cr}) vs Relationship of Diameter of Detonator (d_{det}) to Diameter of Charge (d_{chge})

Critical Mass in Chain Reactions. See Vol 1, p A501-L, under Atomic Energy

Critical Mass of Explosive. The minimum quantity of an expl required for development of detonation; it varies widely for different types, being only milligrams for sensitive primary expls and pounds or tons for "non-detonating" expls like colloided proplyts and AN
Ref: Dunkle's Syllabus (1957-58), 157-58

Critical Phenomena. This includes critical temperature, pressure and volume

Critical temperature is the maximum temperature at which a gas or vapor can be liquefied by application of any pressure, however great, such as the *critical pressure* which is the pressure at its "critical point". *Critical volume* is the volume occupied by unit mass (one mole) of a substance at its "critical temperature" and "critical pressure"

Critical Phenomena in the Detonation of Gases. This subject was discussed in two papers published by J.E. Lennard-Jones & A.F. Devonshire in ProcRoySoc **163A**, 53-70 (1937) and **165A**, 1-11 (1938). Abstracted very briefly in CA **32**, 1533 & 6118 (1938)

Equation of state discussed in these papers is given in this Volume under "Detonation (and Explosion), Equations of State", as "Lennard-Jones & Devonshire Equation of State"

Critical Phenomena in the Detonation of Liquid Explosives. This subject is discussed by A.N. Dremin in the 12th SympCombstn (1968), published in 1969, pp 691-99

Critical Point. A point where two phases, which are continually approximating each other, become identical and form but one phase. With a liquid in equilibrium with its vapor, the critical point is such a combination of temperature and pressure that the specific volumes of the liquid and its vapor are identical and there is no distinction between the two states (Ref 2, pp 188-89)

A very convenient summary of the behavior of a substance is provided by a pressure-volume

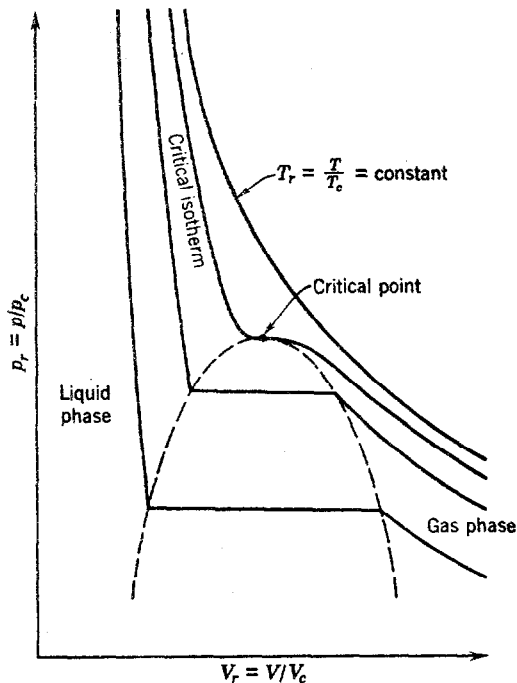

Fig. 4.1-1 Characteristic pattern of isotherms

(p, V) diagram with *isothermals* (lines of equal temperature) of the substance traced on it. Such a diagram is presented in Fig 4.1-1, p 238 of Ref 3. The adjective "critical" is also applied to temperature, pressure, volume and density existing at that point (Ref 1, p 269). Methods for determining critical point on the "critical isotherm" are given in Ref 3, pp 357-63 (See also under "Corresponding States" and under "Critical Phenomena")

Refs: 1) S.G. Starling & A.J. Woodall, "Physics", Longmans-Green, London (1950) 2) Van Nestrands' Dict (1953) 3) J.O. Hirschfelder, C.F. Curtiss & R.B. Bird, "Molecular Theory of Gases and Liquids", Wiley, NY (1954) 4) Dunkle, private communication, Jan 1968

Critical Prepressure Value. Wachtell & McKnight (Ref 1) proposed this term and suggested it as a measure of detonability (See Detonability and Flammability in this section). They postulated that this value represents the pressure at which a solid structure shatters to give a sudden increase of the burning surface by many orders of magnitude. They suggested that at a "critical" value of the prepressure, in charges of either HE's or solid proplnts,

the burning rate "runs away", ie turns upward from the straight line log/log plot of burning rate v pressure

Refs: 1) S. Wachtell & C.E. McKnight, pp 635-58 in the 3rdONRSympDeton (1960) (Determination of Detonability of Explosives and Propellants) 2) C.G. Dunkle, private communication, Dec 1967

Critical Pressure. See under "Critical Phenomena"

Critical Temperature. See under "Critical Phenomena"

Critical Velocity (of Projectile). See Vol 3 of Encycl, p C561-R

Critical Velocity and Limiting Velocity of Detonation. See Detonation Velocity, Critical and Limiting

Critical Volume. See under "Critical Phenomena"

Cruciform Luminosity Produced by Detonation of Explosive Cartridges of Square Cross Section. See Vol 3, p C563-R

Crushing Impact, Sensitivity of Explosives to. See Vol 3, p C567-L

Crystal Size Influence on Detonation Velocity. See Detonation Velocity - Crystal Size Relationship

Cumulative Initiation (or Ignition). See Vol 3, p C575-L

Current, Thermal in Gaseous Detonations. See Cook (1958), 165-66

Current, Thermal at the Wave Front in Granular Explosives. See Cook (1958), 164-65

Curvature of Wave Fronts. In many discussions of stable detonation waves plane wave fronts are assumed to exist. Actually stable, plane wave fronts do not exist, at least in condensed expls as shown by Cook et al (Ref 1)

Below are summarized some of the important results of these studies:

- a) The wave front emerging from the end of an unconfined cylindrical charge was, generally, in spherical segment shape both in ideal and nonideal expls, except at the very edge of the chge where slight "edge effects" (qv) may sometimes be observed
- b) The radius of curvature, R , of the "spherical wave front" for point initiation of a cylindrical chge increased at first geometrically ($R=L$) but quickly settled down to a constant or "steady-state" value R_m significantly at $L \leq L_m$. Here L is charge length, $L_m = \text{max effective chge length}$, $R = \text{radius of curvature of wave front}$ and $R_m = \text{steady-state radius of curvature}$
- c) The steady-state curvature-diameter ratio R_m/d varied from ca 0.5 at the critical diam d_c to a maximum of 3 to 4 at $d \gg d_c$. For ideal expls R_m/d generally fell betw 2.0 & 3.5
- d) The wave shape observed at large L/d was independent of the type of initiator used in the initial wave shape. While one may, by the use of appropriate wave-shaping boosters, initiate a chge to propagate initially with almost any desired wave shape, as L increases, the shape of the front quickly reverts to the steady-state spherical one of $R=R_m$ characteristic of the expl (Ref 2, pp 99-100)
- e) Other results of studies by Cook et al are given in Ref 2, pp 100-106
- f) Finally, the facts that deton wave fronts propagate in steady-state in all cases as spherical segments and that the transition from geometrical expansion (where $R=L$) to steady-state (where $R=\text{const}=R_m$) is quite abrupt, in some cases, at least seem to show the absence of pressure gradients across the wave front; otherwise expansion would not be geometrical. It follows that at the limit of geometrical expansion ($L=R_m$), especially in those cases where transition is quite abrupt, no pressure gradient should exist across the wave front. But wave shape remains unchanged for $L > R_m$; it maintains the same spherical shape for $L > R_m$ that it had at $L=R_m$. Hence, in these cases at least no appreciable pressure gradient could develop across the wave front at any state of propagation since the appearance of a pressure gradient beyond

$L=R_m$ would change the wave shape. Furthermore, if pressure gradients were to develop, sphericity of the wave front would quite likely not be general

Refs: 1) M.A. Cook et al, JApplPhys **27**, 269 (1956) 2) Cook (1958), 99-106

Curved Front Theory of Detonation of Eyring et al. See Detonation, Curved Front Theory of Eyring et al

Cutoff of Detonation. See under Detonation, Attenuation, Break, Cutoff, etc

Cutting of Metal Plates with High Explosive Charges is discussed by W.H. Drummond in JApplMech **25**, 184-88 (1958)

Cybernetics. The scientific study of those methods of control and communication which are common to living organisms and machines, esp as applied to the analysis of the operations of devices such as *computers*
Refs: 1) C.L. Barnhart, ed, "The American College Dictionary", Random House, NY (1952), p 301-L 2) H.S. Tsien, "Engineering Cybernetics", McGraw-Hill, NY (1955) 3) Ord-TechTerm (1962), 89

Cylinder Test for Determination of Metal Acceleration of Explosives of Kury et al is briefly described in this Vol under "Brisance, Determination by Method of Acceleration by Explosives"

Cylindrical Detonations. See Cylindrical Explosions in Vol 3 of Encycl, pp C634-R - C636 and also: J. Brossard et al, "Propagation and Vibratory Phenomena of Cylindrical and Expanding Detonation Waves in Gases", 11th-SympCombstn (1967), pp 623-33

This paper reviews many expl studies carried out over the last decade involving non-steady detonation waves produced in a variety of mixtures, under various geometric constraints of the containers, and with the use of various initiating devices. Review includes recent advances of the so-called "cylindrical detonations" that contributed significantly toward a qualitative understanding of the divergent as well as convergent wave phe-

nomena. The reasons why this cannot lead to a satisfactory agreement with theoretical analysis are discussed. It is also demonstrated that, in contrast to this, there are good reasons to expect that such an agreement should be achieved in the case of so-called "spherical detonations"

D

Damage Caused by Detonations (and Explosions). See under Damage Effects of Organic High Explosives in Vol 3 of Encycl, p D3-L

Damage Effects of Organic High Explosives. See Vol 3, p D3-L

Damage Potential of Air and Ground Blast Waves. See Vol 3, p D3-R

Damming of Explosives. See Vol 3 of Encycl, p D4-L

Danger of Handling Explosives. See Vol 3, p D5-L

Dangerous Explosives. See under Dangerous (Hazardous) Chemicals in Vol 3, pp D6 to D15

Dangerous Materials, Shipping and Storage of. See Vol 3, p D16

Dark Waves. See under Detonation (and Explosion), Luminosity, etc

Dautriche Method for Determination of Detonation Velocity. See Item H under CHRONOGRAPHS in Vol 3, p C311-R

Dead-Pressed Explosives. See Vol 3, p D20-L

Decay (or Fading) of Detonation. See Detonation, Decay (or Fading)

Decaying Detonation Waves. See under Detonation Waves and Shock Waves

Decomposition of Explosives and Propellants. See Vol 3, pp D23 - D35 under DECOMPOSITION, DESTRUCTION AND DISPOSAL OF AMMUNITION, EXPLOSIVES AND PYROTECHNIC COM-

POSITIONS. Chemical Decompositions are briefly discussed in Vol 2, p C173-L

Decomposition, Thermal of Explosives and Propellants. A brief description was given in Vol 2, p B357-R, under Burning Ground and to this may be added the following discussion:

All expls (and proplnts) undergo thermal decompn at temps far below those at which expln occurs. This reaction is important in determining their stability. For example, accdg to Hainer (Ref 4, p 224), the hazard in AN arises, on the one hand, from its exothermic decompn and, on the other hand, from the release of gaseous products in considerable volume. Because of the commercial importance of 3-percent, wax-coated fertilizer grade AN(FGAN), which was involved in the Texas City disaster (See Vol 1 of Encycl, p A364 and Ref 1), Hainer observed the rate of decompn of this material over a wide temp range. Discussing the hazard of spontaneous heating, Hainer (Ref 4, p 227) noted that above a critical size more heat is released within the material than is lost (Ref 8, p 137)

Refs: 1) P.F. Macy et al, "Investigation of Sensitivity of Fertilizer Grade Ammonium Nitrate to Explosion", PicArns SFALTech-**Rept 1658**(1947) 2) E. Harvey et al, **JACS 76**, 3270(1954) (Kinetics of isothermal decompn of K perchlorate) 3) Inst of Study of Rate Processes, Univ of Utah, "The Isothermal Decomposition of Tetryl and Hydrazine Nitrate", TechRept No **XL111** (Dec 1954); Contract N7-onr-45107 4) R.M. Hainer, pp 224 & 227 in 5thSympCombstn (1955) 5) E.S. Freeman, **JACS 79**, 838-42 (1957) (Kinetics and thermal decompn of K nitrate) 6) P. Gray & T.C. Waddington, **PrRoySoc 241A**, 110-40 (1957) (Thermal decompn of Ag azide) 7) Cook(1958), 39-41, 125-28, 133-38, 172-83 & 333 8) Dunkle's Syllabus (1958) 137 9) D.H. Fine et al, "Experimental Measurements of Self-Heating in the Explosive Decomposition of Diethyl Peroxide", 12thSympCombstn, Poitiers, France, July 14-20, 1968. Abstracts of Papers, pp 100-02

Decomposition, Thermal of Explosives and Propellants. Influence of Pressure and Temperature. It is important to keep in mind the distinction betw the effects of pressure and temperature on the beginning of thermal decompn of expls and proplnts and on its progress once it is started. Often the effects of pressure and temp are similar as, for example, when hydrocarbon mixtures are subjected to high pressure and temp simultaneously. In some of these cases "nonflammable" gas mixts might become explosive, "mild reactions" become violent and "stable" gas mixtures become spontaneously reactive (Ref 10, p 143)

Eyring et al noted (Ref 5, p 55) that when an expl is so loosely confined that no pressure wave could be built up, it will burn quietly but will not detonate. For example, Belyaev found that even MF will decomp quietly if ignited by a hot wire in vacuo. The contrary phenomenon has also been noted: high temps and pressures caused deton in a material which ordinarily only decompd on heating quietly. Thus Urbański (Ref 3) reported that NC proplnt can be made to detonate with velocity up to 7700 m/sec (See also Ref 10, p 143)

Accdg to Dunkle (Ref 11, p 156 and private communication), high pressures and temperatures may not be enough to cause a detonation and it seems to require some "shock processes". Dunkle also stated that accdg to G.B. Kistiakowsky, as stated in Ref 8, W.F. Jackson found at Burnside Laboratory that such readily detonatable materials as Tetryl, RDX and PETN deflagrate controllably in closed bombs at pressures reaching 6000 kg/cm², provided the ignition is such that all parts of the granular charge are ignited simultaneously and without pressure surges. The burning rates were in general higher for the more powerful and more readily detonable explosives which in general have higher heats of expln. The behavior was so similar to that of colloidal propellants with comparable heats of expln that it may be safely assumed that both classes of expls deflagrate by the same kinetic mechanism

Dunkle also reported (Ref 10, pp 120 & 143) that Poulter in an unclassified part of his conf report (Ref 9) noted that the burning

rate of a propellant or high explosive depends primarily on the extent to which the energy released by the chemical reaction is retained in the immediate vicinity or is allowed to be dissipated by rapid expansion. The stronger the confinement or the greater concn of heat, the higher the rate of reaction. For example, a 1-lb stick of Comp C-2 if burned at a high altitude may require many minutes to be consumed or may even quench. At 1 atm it may require ca 3 mins to burn completely, whereas at a pressure of a few atms it may be consumed in less than half a minute. The same 1-lb stick of C-2, if surrounded by material at very high temp of 5000° F, would be completely consumed in a few seconds without detonating. If, on the the other hand, it is subjected to a shock of proper intensity it may detonate entirely at low order, or partially at low order changing over, after awhile, to high order. It may also detonate entirely at high order, the entire procedure requiring from 100 to as little as 10 microsecs. The property of HE's to function at low-order as propellants has been utilized in seismic prospecting, such as in Poulter methods described in the book of Cook (1958), pp 338-39)

Accdg to Ryabinin (correct spelling is Riabinin) (Refs 6 & 7), some investigators stated as early as in 1930's (Ref 1, 2 & 4) that extremely high pressures developed during detonation of condensed expls, favor the thermal decomposition, thus increasing the rates, but this point of view was not proven experimentally until it was done by Ryabinin. He proceeded in the following manner:

A small sample of expl was placed betw an anvil and plunger of a small hydraulic press where it was compressed in the form of a tablet to ca 2500 kg/cm². Then the press with the tablet was placed in an electric oven where it was heated for exactly 3 minutes at the temp close, but below, temp of decomposition reported in the literature. Then the sample was cooled to RT and dropped on the bottom of a metallic dish preheated to the temp slightly above the one used in the test. Parallel with this test, a 2nd sample of the same expl was compressed in cold to ca 25000 kg/cm², removed from the press and heated for 3 mins at atm pressure and at the

same temp as the 1st sample. Then it was cooled and dropped in the same heated dish as above. If the 1st or 2nd sample was not already decomposed during 3 mins heating, it would flash when brought in contact with hot dish, but if it is already decompd, no flash would be observed. If both samples flashed, experiments were continued at higher temps until the flash of each sample started to diminish in intensity. This was taken as the point of "initial stage of decomposition". The test was continued until the flash completely disappeared and this was taken as the point of "final stage of decomposition"

In the following Table I, T_1° is the temp at which a tablet heated at atm pressure commenced to decompose (initial stage) and T_p° the corresponding temp for a sample heated under high pressure; T_1^+ temp of final stage of decompn of sample heated under atm pressure and T_p^+ corresponding temp for sample heated under high pressure. The difference betw initial stage temps of decompn at high and atm pressures, $T_p^\circ - T_1^\circ$, is designated as ΔT° and for the final stage, $T_p^+ - T_1^+$, is ΔT^+ . These values mean that in order to obtain the same rate of decompn at high pressure as at atm pressure the temp should be shifted to the value of ΔT° or ΔT^+ . If this value is positive, it means that higher temp is required to achieve the same rate of decompn at high pressure as at atm one and that pressure diminishes the rate of decompn. If the ΔT value is negative - the pressure increases the rate of decompn

Table I

| Substance | T_1° | T_1^+ | T_p° | T_p^+ | ΔT° | ΔT^+ |
|----------------------------|-------------|---------|-------------|---------|------------------|--------------|
| Pb Styphnate | 270 | 276 | 243 | 254 | -27 | -22 |
| Hg ⁺⁺ Fulminate | 147 | 155 | 128 | 161 | -19 | +6 |
| Pb Azide | 314 | 319 | 314 | 331 | 0 | +12 |
| PETN | 186 | 190 | 220 | 227 | +34 | +37 |
| Ba Azide | | 168 | | 233 | | +65 |

In Table II is shown the influence of pressure on decomposition rates, as detd by Ryabinin (Ref 7)

Table II

| Substance | n° | n^+ | Pressure Thousands kg/cm ² |
|-----------|-----------|-------|---|
| LSt | 7.0 | 4.6 | 25-33 |
| MF | 5.8 | 0.60 | 25-33 |
| LA | 1.0 | 0.45 | 21-31 |
| PETN | 0.05 | 0.04 | 24-30 |
| BaA | | 0.02 | 27 |

Here n is the ratio of decompn rate at the higher pressures referred to that at atmospheric pressure; superscripts $^\circ$ and $^+$ mean, respectively, the initial and the final stages of decompn under experimental conditions

From the data of these tables may be drawn the following conclusions:

- The influence of very high pressure on the rate of thermal decompn of expls is not as great as was sometimes reported in the literature
- For some expls the pressure decreases the rate of thermal decompn, while for the others it increases
- Among the expls investigated by Ryabinin, the high pressure increased both initial and final rates of thermal decompn of Lead Styphnate; it increased also the initial stage of decompn of Mercuric Fulminate, but decreased its final stage of decompn. The initial stage of decompn of Lead Azide was unaffected by high pressure, while its final stage appreciably diminished. In cases of PETN and Barium Azide, the high pressures diminished the rate of thermal decompn in both initial and final stages
- The "Rule of LeChatelier" would predict slower decompn at higher pressures. The cases noted, as well as the initial decompn of LA, appear to be exceptions. Ryabinin suggests that they may be due to greater ease of developing high temp in the expl on initiation at high pressure, and to higher thermal conductivity (Refs 6, 7 & 8)

Influence of temperature on decomposition is discussed in Ref 12

Refs: 1) W. Taylor & A. Weale, PrRoySoc **138A**, 92 (1932) 2) A. Schmidt, SS **30**, 12 (1935) 3) T. Urbanski, SS **34**, 103-05 (1939)

(Engl transl by J.D. Hopper) 4) R.K. Leroy, *JFranklInst* **230**, 75 & 207 (1940) 5) H. Eyring et al, "The Chemical Reaction in a Detonation Wave", OSRD Rept **3796** (1944) 6) Yu.N. Ryabinin (Riabinin), *ZhFizKhim* **20**, 11 (1946) 7) Ibid, *DoklAkadN* **58**, 245-48 (1947) (Abbreviated translation by B.T. Fedoroff) 8) G.B. Kistiakowsky, "Initiation of Detonation of Explosives", 3rd Symp-Combustn (1949), pp 560-65 9) T.C. Poulter, "A Report on Recent Basic Studies on Detonation of High Explosives", SRI Poulter Laboratories, LabTechRept **010-57**, May 20, 1957. SAC 14th Meeting 25-26 April, 1957 (Conf); Unclassified part pp 83-92 10) Dunkle's Sullabus (1957), 111, 120 & 143 11) Ibid (1958), 156 12) K.K. Andreev, *Explosivstoffe* **10**, 229-37 (1962) & *CA* **58**, 5446 (1963) (Thermal decompn and combustion processes with expls) [See also *CA* **55**, 8861f & 10891a (1961)]

Deflagrating Explosives. See Vol 3 of Encycl, p D38-R and the following
Addnl Refs: A) W.A. Wood, *ProgrAstronRocketry* **1**, 287-91 (1960) & *CA* **58**, 3261 (1963) (Combustion of Al and Mg in deflagrating propellant) B) W.H. Anderson, *JChemEngData* **8**, 111-12 (1963) & *CA* **58**, 5445 (1963) (Dichromate catalysis of deflagrating AN) C) F.A. Loving, USP 3092528 (1963) & *CA* **59**, 6192 (1963) (A deflagrating composition for use in underwater seismic explorations, which is a better source of seismic energy than BkPdr, consists of a substantially O balanced mixt of Na nitrate 21.6-61.9, sulfur 3.6-10.3, charcoal 4.5-12.9, metallic fuel 5-25, K perchlorate 9-45 and starch 0.3-0.9%. Of the metallic fuels Al, Mg, Fe or ferrosilicon, Al is preferred with a particle size betw 5 and 500 microns) D) N.P. Suh & G.C. Fuller, *FrP* 1465178 (1967) & *CA* **67**, 7089 (1967) (Deflagrating explosive pellets consisting of double-base propellant grains coated, at least on their cylindrical surfaces, with Ni ca 0.015 mm thick and having a total linear resistance of 0.012-0.017 ohm. The pellets can be deflagrated by passing electric current thru the coating, thus eliminating the use of any initiating devices. Such pellets can be

used for expanding hollow rivets, activating pistons and for propelling projectiles. The method of coating is described in the patent and in CA)

Deflagration. See Vol 3 of Encycl, p D38-R and the following
Addnl Refs: A) L.V. Dubnov & A.I. Romanov, "Deflagration of Permitted Explosives in Mines", *Bezopastost'Truda v Promyshlennosti* **6**, No 10, 20-5 (1962) & *CA* **58**, 4367-68 (1963) B) J. Hershkowitz, "The Combustion of Potassium Perchlorate and Aluminum Considered as Either a Deflagration or Detonation", *PATR* **3063** (1963) C) F. Schuster, *InternZGaswaerme* **13**(4), 135-8 (1964) & *CA* **61**, 10526 (1964) (Use of terms "deflagration", "explosion" and "detonation" to describe certain combustion processes with unstable flames in gaseous fuels. A "detonation" is connected with an adiabatic shock wave of velocity up to 4 km/sec. An "explosion", however, takes place at the flame propagation or combustion rate of the exploding material and a "deflagration" denotes the lowest rate)

Deflagration, Chapman-Jouguet. See a brief definition given under Detonation, Chapman-Jouguet

Deflagration, Development (Transition) from Combustion (Burning) of Explosives and Propellants. If a mass of an unconfined expl or proplnt is small, thermal ignition usually, if not always, leads to burning (combustion) (See Vol 2 of Encycl, pp B343-L to B362-L and Vol 3, pp C425-L to C433-L

If a mass exceeds a certain value, or if ignition is conducted under confinement, it is possible for burning to become so rapid that it develops into deflagration or even into detonation

Development of deflagration is discussed in Vol 3 of Encycl, p D38-R. under "Deflagrating Explosives and Deflagration", and development of detonation from burning or from deflagration is discussed in this Vol under "Detonation (and Explosion), Development (Transition) from Burning (Combustion) or from Deflagration"

(See also previous item and the item which follows)

[See also some refs under Detonation (and Explosion) Development (Transition) from Burning (Combustion) or Deflagration]

Deflagration, Development (Transition) from Combustion (Burning) in Powdered Explosives.

This problem was examined, among other investigators, by K.K. Andreyev & S.V. Chuiko and reported in *ZhFizKhim* **37**(6), 1304-10 (1963); *CA* **59**, 6190 (1963). The burning velocity, u , of powdered PETN, RDX & some other HE's was studied as a function of the pressure, p , and the size of grains, d , by photographic registration. At a const p up to 60 atm, powders of small d (ca 5μ) and a density $\delta=1.17$ burned regularly as pressed strands. At higher p , up to 1000 atm, u increased rapidly until the transition, p_{tr} , was reached at which deflagration developed.

This transition, p_{tr} , increased with δ . For the same $\delta=0.66$, it was higher for powders with $d=5\mu$ than with $d=200\mu$. For powders with $d=200\mu$ and $\delta=1.17$, p_{tr} for PETN was 50 atm, whereas for RDX it was much lower. For powders with $d=5\mu$, u increased to a pronounced maximum with δ and decreased to a constant low value at high δ . At p up to 1000 atm, $d=200\mu$, and $\delta=0.57$, the powders did not detonate. The plot p_{tr} vs $1/\eta$ was a linear function, where η is the gas permeability of the powder

Deflagration to Detonation Transition (DDT). See Vol 3 of this Encycl, p D38-R and under Detonation and Explosion, Development (Transition) from Deflagration or Burning (Combustion)

Deflagration to Detonation Transition and Shock Interaction is discussed by Cook (1958), pp 183-87

Deflagration, Heat of. See under DETONATION (AND EXPLOSION), DEFLAGRATION (AND COMBUSTION), AND FORMATION, HEATS OF

"Deflagration Point" of Graphite Oxide. Accdg to H.P. Boehm & W. Scholz, *ZAnorgAllgemChem* **335**(1-2), 74-9 (1965) & *CA* **62**, 12965-66 (1965),

graphite oxide (GO) is thermally unstable and decomp by slow heating into black C, carbon oxides and water. Deflgrn occurs after fast heating with formation of GO-carbon black. The deflgrn point is influenced by the prepn method and lowered considerably by impurities
Note: It seems that "deflagration point" is the same as "deflagration temperature"

Deflagration, Pressure of. See under Detonation, Explosion, and Deflagration, Pressures of

Deflagration (or Explosion) Temperature of, Determination. See Vol 3, pp C444-L to C450-L

Deflagration (or Explosion) Temperature Test. See under Ignition (or Explosion) Temperature Test in Vol 1 of Encycl, p XVI and K.K. Andreyev, *Explosivst* **10**, 229-37 (1962) & *CA* **58**, 5446 (1963)

Deformation and Break-Up of Solids by Detonation (and Explosion). The response of solids to impact of detonation and shock waves is important to the development of wave-shaping techniques required for adequate control of the action of an expl (Ref 14, p 320)

Impulse transmitted by a detonation front to a metal (or other solid) target is greatest in case of normal impact, and decreases as the angle betw wave front and metal surface increases. Normal impact boosts the velocity by superimposing, on the detonation pressure, the dynamic pressure due to the very high particle velocity in the direction of the target (Refs 9 & 15). Particle velocity can be detd by the method which consists of measuring the depth of the engravement or indentation which is left on the surface of an impulsively loaded body by a pellet that had been previously affixed to the surface, and calculating the average particle velocity from the equation

$$u_{av} = cd/2L$$

where: c = the velocity of propagation of the wave,
 d = depth of the impression, and
 L = the thickness of the pellet
(Refs 8 & 15)

The following studies of detonation & expln action on solids are mentioned, among others, in Ref 15, pp 321-27

- a) Subjecting thick-walled cylinders to explns of charges placed inside of them (Ref 8)
- b) Subjecting magnesium alloy articles to contact detonations (Ref 6)
- c) Studies of mechanism of scabbing and spalling caused by reflection of an intense shock wave in a solid against a free surface; the shock wave being of the type formed by high-order deton of an expl in direct contact (Ref 7)
- d) Subjecting one end of a metallic bar to a strong compression pulse causes the crushing of that end if the compressive stresses are higher than the dynamic stress of the bar material (Ref 10)
- e) Application of the "explosion-bulge-test" for evaluation of welding methods. This test is unique in subjecting all zones of the weldment to simultaneous testing in all vector directions, and hence should most closely approximate the drastic conditions of military use, which involves massive plastic deformation areas resulting from enemy expl attack (Ref 11)
- f) An application of the "explosion-bulge" technique to the so-called "contour-shaping" of metal sheets, such as of titanium is described in Ref 12
- g) An action of "contact detonation" (i.e. when an explosive is in immediate contact with an object to test) on plates of lucite, magnesium, Dural, steel, copper, brass, lead and monel is described in Ref 4a and the action on aluminum plates in Ref 14
- h) Study of deformation and break-up of bomb and shell cases on explosion was studied by Mott (Ref 1), Pearson & Reinhart (Refs 2 & 3) and by Hänsel of Schardin's group (as was reported by Reinhart)
- i) Singh (Ref 5) discussed deformation produced in armor plates
- j) A new method for recording expln impulse effects on solids was discussed by Bron et al (Ref 13)
- k) The Lehigh Univ rept (Ref 4) gave new techniques for producing strain pulses and discussed geometry and basis of measurements
- Refs: 1) N.F. Mott, "Fragmentation of Shell Cases", *PrRoySoc* **189A**, 300-08(1947)
- 2) J. Pearson & J.S. Reinhart, "Deformation and Fracturing of Thick-Walled Steel", *JApplPhys* **23**, 434-41(1952) 3) J.S. Reinhart & J. Pearson, "Conical Surfaces of Fracture Produced by Asymmetric Impulsive Loading", *JApplPhys* **23**, 685-87(1952) 4) LehighUniv-Inst of Research, "Plastic Deformation and Fracture of Metals at High Rates of Strain", Final Rept on Contract DA 36-034-ORD-1456, Proj TB 2-0001(87), 28 Aug 1953 to 27 Aug 1954, Bethlehem, Pa 4a) R.G. Schreffler & W.E. Deal, "Free Surface Properties of Explosive-Driven Metal Plates", *JApplPhys* **24**, 44(1953) 5) S. Singh, "Principles of Armor Penetration", *JSci&IndRes (India)*, Dec **1954**, 317-24 6) J. Dewey et al, "Some Observations of Elastic Properties of Solids Under Explosive Loading", *RRL* **931**, (Apr 1955) 7) K.B. Broberg, "Studies of Scabbing of Solids under Explosive Attack", *JApplMechanics*, Sept **1955**, 317-23 8) J. Pearson & S. Reinhart, "Application of the Engraving Method to the Study of Particle Velocity Distribution in Explosively Loaded Cylinders", *JApplPhys* **26**, 1431-35(1955); *NOTS* **1385**, *NavOrd* **5040**, (2 Mar 1956) 9) C.H. Bagley & T.C. Poulter, "The Application of Wave Shaping", Unclassified Paper, presented during secret Proceedings of Detonation Wave Shaping Conference (5-7 June 1956) 10) S. Kumar & N. Davids, "Multiple Scabbing of Metals", *JFrankInst* **263**, 295-302(1957) 11) P.P. Puzak, "Explosion-Bulge-Test Performance of Low-Carbon Ni-Cr-Mo-B Quenched and Tempered Steel Weldments", *NRL Rept* **4919** (May 17, 1957) 12) C.H. Wick, "Titanium Formed at Ford by Heating, Rolling and Exploding", *Machinery* **63**(11), 184-89(1957) 12a) T. Sakurai, *Kôgyô-KayakuKyôkaishi* **18**, 225-36(1957) & *CA* **51**, 17167(1957) (Plastic deformation flow of solids produced by deton of expls) 13) W.E. Bron et al, "New Method for Recording Explosion Impulse Effects on Solids", *ASTM Bull* **50** (TP38) (1957) 14) J.M. Walsh et al, "Shock Wave Compressions of Twenty-Seven Metals", *PhysRev* **108**, 196-216 (Oct 2, 1957) 15) Dunkle's Syllabus (1957-1958), pp 320-23 (Deformation of solids); 323-25 (Metal-charge interactions)

Deformation and Fracturing of Thick-Walled Steel Cylinders under Explosive Attacks. See Vol 3 of Encycl, p D40-R

Delayed-, After-, or Post-Reactions in Detonation. There are two general types: those which occur within a confined space such as in a closed bomb, and those which involve reaction with external air and are known as "afterburning". Accordg to classical one-dimensional detonation theory, chemical equilibrium is achieved and reaction ceases at the CJ (Chapman-Jouguet) plane, which terminates the reaction zone. In some cases, however, as noted by Craig (Ref 3, p 863), the sharp shock wave and the reaction zone of falling pressure are followed by a further rapid pressure drop which is not predicted by an extrapolation of the one-dimensional theory

It was noted by Kistiakowsky & Zinman (Ref 1, p 94) that in fuel-rich acetylene-oxygen explosions, nucleation of carbon may occur in the rarefaction zone beyond the C-J point with liberation of energy and, under some conditions, may advance into the reaction zone and accelerate the detonation

It is quite possible in the case of TNT that the true detonation reaction is followed, during the cooling of the products, by endothermic reactions among them, which increase the volume of gas found in the calorimetric bomb at the end of the determination. These could be the "soot" reactions:

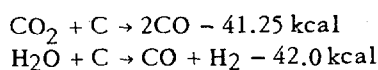

When there is contact betw hot deton products which are rich in reducing gases such as CO and H₂, and the open air, "afterburning" can greatly increase the over-all energy evolution even though it occurs too late to expedite the true detonation reaction (Ref 4, p 5). Such afterburning is particularly important for aluminized expls, which in general are oxygen deficient. It has been suggested (Ref 2, p 275) that in the primary detonation front Al reacts very slowly or oxidizes only to AlO or Al₂O, and C-J temperatures and pressures for low-density TNT/Al and RDX/Al

expls accord with this supposition. If these low oxides rather than Al₂O₃ are formed in the detonation front, then expls of this type have a positive oxygen balance, rather than an oxygen deficiency, for the primary detonation reaction. Much more heat is evolved when these lower oxides go to Al₂O₃ during the afterburning. However, this highly exothermic reaction apparently never suffices, in Tritonal and HBX, to overcome the endothermicity of gaseous Al₂O at the C-J plane. Thus detonation velocities and pressures, and hence the brisance, of these expls are low even at maximum densities. However, they are very effective for underwater & underground expls and air blast because of the long duration of their maintenance of sustained pressure (Refs 2 & 5)

Refs: 1) G.B.Kistiakowsky & W.G. Zinman, 2ndONRSympDetonation(1955), p 94 and JChemPhys **23**, 1894 (1955) 2a) Dunkle's Syllabus (1957-1958), 275-76, 293 & 323-25 2b) Ibid (1960-1961), pp 23a, 24e & 24f 3) B.G. Craig, 10thSympCombstn (1964), 863 4) C.G. Dunkle, "Energy Relationship in the RDX-TNT System", APL (Applied Physics Laboratory), Johns Hopkins Univ, Report **CGD/M-10**, Silver Spring, Md, July 22, 1964, p 5 5) C.G. Dunkle, private communication, December 1967 and August 1968

Delay to Detonation, Explosion or Ignition, also known as *Induction Period*. See Detonation (and Explosion), Induction Period and also the discussion, which is given in the book of Baum, Stanyukovich & Shekhter (1959), pp 24-30. A resumé of this discussion is given here under Detonation (Explosion, Deflagration or Ignition) Temperature

Delay to Ignition and Its Temperature Coefficient. See Vol 3, pp D53 & D54

Demolition and Demolition Explosives. See Vol 3, p D56-R and the following *Addnl Refs:* A) E.D. Davis & S.C. Hunter, "The Classification of Some Demolition Explosives by Pressure Bar Test", ARDE Memo (MX) **53-58** (1958) B) Dunkle's Syllabus (1957-1958), 306-10 (Calculation of charges for demolition expls)

Demolition Hoses and Snakes. See Vol 2, p B17-R of Encycl under Bangalore Torpedoes

Density-Brisance Relationship. Judging by Table 1, pp B 266ff in Vol 2 of Encycl, brisance increases with initial density of expls. Although the relationships are obscured by the uncertainty in definition and measurement of brisance, high initial densities favor high detonation pressures (See Density-Pressure of Detonation Relationship in this Section), and these definitely contribute to brisance. The trend toward high detonation velocity at high density has also been noted, as indicated in Table II, p B298 in Vol 2 of Encycl) and since there is a direct relationship betw brisance and detonation velocity, there is also a direct relationship betw brisance and density. It may also be noted that "shattering power", one of the terms for brisance (another term is "impetus") is an indirect effect of high values of detonation energy and detonation pressure, which are generally accompanied by high detonation velocity and which lead to generation of strong shock waves with spalling and other destructive effects on confining media

Ref: C.G. Dunkle, private communication, December, 1967

(See also in this section: "Brisance, Correlation with Chemical Structure"; "Brisance, Correlation with Properties Other Than Chemical"; and "Brisance, Determination by Method of Metal Acceleration by Explosives")

Density - Detonation Pressure and Density - Temperature of Detonation Relationships. See under Detonation Pressure - Charge Density and Temperature of Detonation - Charge Density Relationships

Density - Detonation Velocity - Diameter of Charge Relationships. See under Detonation Velocity - Charge Density Relationship and Detonation Velocity - Charge Diameter Relationship

Density - Diameter and Detonation Velocity Relationships. See under Detonation Velocity - Charge Density Relationship and De-

tonation Velocity - Charge Diameter Relationship

Density - Distance Relationship. Description of X-Ray technique for measuring the relationship between density of a detonating explosive and distance is given by T.K. Collins et al in Univ of Utah ERG Technical Report No 53 (1957), Contract No N7-onr-45107

Density, Limiting - Diameter, Limiting and Detonation Velocity Relationships. See under Detonation Velocity - Charge Density Relationship and Detonation Velocity - Charge Diameter Relationship

Density - Temperature of Detonation Relationship. See under Detonation Pressure Charge Density and Temperature of Detonation - Charge Density Relationships

Destructors. See Vol 3 of Encycl, pp D62-R and D92-R

Detonability and Flammability of Explosives, Propellants and Pyrotechnic Compositions.

"Detonability" is the tendency (ability) to detonate, or the ease with which detonation can be accomplished, whereas "flammability" is the ability to be easily set on fire (ignite) and then continue to burn or deflagrate. All expls, proplnts and pyrotechnics are flammable under certain conditions, but not all of them are detonable, especially if they are not under confinement or taken in a large mass, preferably compressed. Many flammable substances can undergo transition from deflagration to detonation. For example, deflagration of porous or granular BkPdr, smokeless proplnts and pyrotechnics can easily "run up" to explosion or detonation. This is because porous or granular substances possess high surface/volume ratios. Such high ratios can also be developed by shattering on impact. In either case confinement is important in promoting propagation of the flame to the larger surfaces exposed. Even momentary confinement, as provided on high velocity impact into sand, may suffice. Quantitative information about the promotion of

flame propagation to an enlarged proplnt surface, particularly under confinement, was gained in a study of flow-assisted flame spread over the freshly cut surface of a composite proplnt under controlled conditions of pressure and flow velocity (Refs 9 & 13)

The energy of explosion of solid proplnts has often been equated with detonability. There is not necessarily, however, any strict correlation between these properties. In fact, rocket motors are well-nigh committed to composite "non-detonable" proplnts. Calcd critical diameters of intact proplnts of this type exceed 30-40 ft. It is generally agreed that "voids" markedly reduce the critical diam and the pressure "jump" required for initiation. Nevertheless it has been experimentally found that very high shock pressures, probably above 50-100 kbar, are required to detonate conventional solid proplnts, and that the critical diameters of the grains exceed 20 inches. There is thus justification for the conclusion that detonation of large solid proplnt grains is unlikely because of the very large initiation energies required. However, despite the difficulty of initiating true high-order detonation in proplnts there is still an important hazard due to flammability. Flammability of gases was discussed by several investigators at the 7th Symp Combstn (1959) and resumé of them was given by C.G. Dunkle in his Syllabus (Ref 5). It was stated that in hydrogen-air mixtures, flammability depends not only on the heat generated but also on the transport properties, whereas detonability depends only on the heat generated, indicating that transport properties here play a minor role

As an example of transition of deflagration to detonation in gaseous expl mixts may be cited "Combustion Knock" described in this Section, pD172-R

Returning to the subject of "detonability", it may be noted, that it has been found difficult to induce detonation without simultaneous application of high pressures and temperatures in both secondary explosives and propellants. There is, of course, considerable heating in a shock compression. For the growth of detonation under marginal circumstances, however, the essential macro-

scopic factor appears to be a pressure rise, specifically a "jump" of 25-30 atm. This initiates a mutual interaction between burning rate and dynamic-pressure rise which leads to detonation more or less instantaneously, depending on the energy content, physical state of the explosive, and the initial pressure, as well as the shock overpressure (Refs 7 & 13)

Kistiakowsky (Ref 1) gave the following description of mechanism for the development of detonation in a large mass of granular or crystalline expls: When the charge is ignited thermally at a localized region within the bulk, the gases which are evolved on burning cannot readily escape between the grains and a pressure gradient develops. The increase of pressure causes, in turn, increase in rate of burning and this condition continues until the shock waves will form. As they will be reinforced by the energy released on further burning, the intensity will finally be reached when the entire energy of reaction will be released for propagation of the shock wave, and formation of a stable detonation wave. A critical size exists for each material above which this deflagration can pass into detonation under proper conditions. Below this size the burning will first increase and then decrease as the material is consumed

The work conducted at Picatinny Arsenal by Wachtell & McKnight (Ref 4) for establishing the detonability of explosives and propellants thru a study of the deflagration to detonation transition (DDT), had shown that each explosive material has a *critical pressure* above which the DDT will occur. The method depended on the determination of burning rate as a function of pressure. By comparing the burning rates obtained in a *strand burner* with those obtained for large solid cylinders in a *closed bomb* at high pressure, a pressure is found for each explosive material above which the closed bomb burning rate vs pressure curve turns sharply upward from the normal burning rate curve vs pressure curve obtained with the strand burner. This deviation is believed to be the result of a crazing or surface cracking of the material causing a rapid large increase in burning area. This increase in burning area is considered to be the basic

intermediate step in transition from deflagration to detonation. The pressure at which this increase in burning surface begins and the rate at which it occurs are used as the basis for a quantitative classification of the detonability of explosive materials

Our Note: Closed bombs are described in Vol 3 of Encycl, pp C330 to C334, under "Closed Bomb (or Vessel)" and the strand burner on p C335. Burning of explosives and propellants was discussed in Vol 2, pp B343 to B357. Additional information is given in Vol 3, pp C425 to C433 under Combustion, etc

Wachtell & McKnight (Ref 4) used for determination of *linear burning rates* (dx/dt , where dx is the distance burning proceeds during any time interval dt) of TNT, Composition B and ARP propellant (See Vol 1 of Encycl, p A488-L) a strand burner using the standard technique at pressures from 1000 to 20000 psi. In the closed bomb tests a cylindrical sample of explosive or propellant 1 to 1-1/4 inch in diameter and 1 to 3 inches long was placed in a 200 ml closed cylindrical bomb with reinforced wall and bottom and ignited with a small amt of Grade A5 BkPdr and an M1A1 Squib. Tracings of typical oscillograms resulting from the firings are shown in Fig 1, p 638 of the report (not reproduced here). For TNT of various densities burning proceeded normally until pressures of 6000-8000 psi were reached and then in each case a marked deviation (break) from normal took place. A similar break took place for Comp B at 4000-5000 psi, whereas ARP propellant required pressures of 35000-40000 psi

(See also Refs 2, 6a, 6b, 6c, 8, 10, 11 & 12)

Refs: 1) G.B. Kistiakowsky, "Initiation of Detonation in Explosives", in 3rdSympCombstn (1949), pp 560-65 2) A.B. Amster, R.L. Bearegard et al, "Detonability of Solid Propellants I. Test Methods and Instrumentation", NavOrd Rept 5788 (1958) 3) Ibid, "Detonability of Solid Propellants II. Sensitivity of Some Double-Base and Composite Propellants", NavOrdRept 6222 (1958) (Conf) (Not used as a source of info) 3a) Ibid, "Solid Propellant Detonability", ARS-J 30, 960-64 (1960) 4) S. Wachtell & C.E. McKnight, "A Method for Deter-

mination of Detonability of Propellants and Explosives", 3rdONRSympDeton (1960), 635-58 5) Dunkle's Syllabus (1960-1961), pp 24d & 24e 6a) W.H. Andersen & R.F. Chaiken, "Detonability of Solid Composite Propellants", presented at the AmerRocket-SocSolidPropellantConference, Salt Lake City, Utah, Feb 1-3 (1961) 6b) J.M. Kuchta et al, "Flammability and Detonability Studies of H₂O₂ Systems Containing Organic Substances", USBurMines RI 5877 (1961) & CA 56, 5010 (1962) 6c) L.V. Dubnov & A.I Romanov, Bezopasnost' Truda v Promyshlennosti 6(10), 20-5 (1962) & CA 58, 4367-68 (1963) (Detonability of some mining expls) (The term "detonability" is used in CA) 7) K.K. Andreyev & S.V. Chuiko, ZhFizKhim 37(6), 1304-10 (1963) & CA 59, 6190 (1963) (Studies in the detonation to explosion transition) 8) W.E. Gordon, "Detonation Limits in Composite Explosives", 10thSympCombstn (1964), 833-38 9) R.C. Mitchell & N.W. Ryan, JourSpacecraft & Rockets, 2(4), 610-12 (1965) (Flame spread on solid propellant) 10) W.E. Gordon, "Detonation Limits in Condensed Explosives", 4thONRSympDeton (1965), 179-97 11) PATR 2700, Vol 3 (1966), pp D38 to D40 (Deflagrating expls and deflagration); p D103-L (Detonability of propellants); p D107 (Detonating expls) 12) Donna Price, "Contrasting Patterns in the Behavior of High Explosives", 11thSympCombstn (1967), 693-702 13) C.G. Dunkle; private communication, December 1967

Note: Resumés of refs 9, 11 & 12 are given in this Section under corresponding titles (See also Detonating Capacity of Explosives)

Detonating Cable. See Vol 2 of Encycl, p B17-L under Bangalore Torpedoes

Detonating Capacity of Explosives, Effect of Various Factors. This is a broad subject which is partly covered in this Section under "Detonability and Flammability of Explosives, Propellants and Pyrotechnic Compositions"

Accdg to Baum et al (Ref 8, pp 56-66), the following factors, besides chemical structure, are influencing sensitivity of expls

to external action: a) Temperature b) Specific heat and thermal conductivity c) Volatility d) State of aggregation e) Physical structure f) Particle size g) Density h) Presence of inert components

a) Sensitivity increases with increase of initial temperature of expl and when the temp approaches "flash point" only a weak impulse is required to cause detonation. Failures often take place at very low temps, such as of liquid air (Ref 8, pp 56-7 & Ref 9, pp 310-11)

b) Influence of specific heat and thermal conductivity concerns chiefly sensitivity to thermal impulse and to a much smaller extent the shock sensitivity. The higher the specific heat and the thermal conductivity the more heat is required to detonate expl. Expls contg alloys, such as Fe-Si & Si-Al, are more affected than nonmetallized expls (Ref 8, pp 57-8)

c) Volatility has great influence on thermal initiation of expls but not on shock or detonator initiation. Accdg to A.F. Belyaev, as quoted by Baum et al (Ref 8, p 58), conditions of ignition of volatile expls depend to a great extent on relation between the rate of chemical reaction and rate of volatilization. The theory proposed by Belyaev was later disputed by K.K. Andreev as explained in Ref 8, pp 58-9)

d) State of aggregation. As a rule, change from solid to liquid phase increases detonability by any means. This is due to the increase in temperature and in internal energy. The excess of energy corresponds to the latent heat of fusion. In case of initiation by thermal means the increase of sensitivity is also caused by the presence of vapors over molten material. Even expls of low volatility, like TNT, evolve in liquid state an appreciable amount of vapor. Although solidly frozen NG is, as a rule, less sensitive than liquid one, there is an exception, when crystals of labile form are present in solid material (Ref 8, p 59 & Ref 9, p 306)

e) Physical structure and

f) Particle size of expls are of great importance in regard to detonating capacity. Gelatinized NC possesses lower sensitivity towards initiators than pressed material. Pressed Guncotton (even contg about 18%

H₂O) can be initiated in the same manner as TNT and was used in Russia as late as WWI as an HE for loading some shells, demolition devices and torpedo heads. Cast expls are less sensitive to initiation than pressed materials of the same densities. A Rus cast expl "Ksilil" which is a cast eutectic mixt of 95% TNT & 5% TNXylene is appreciably more sensitive to initiation than pure TNT and considerably more so than pure TNX. The high sensitivity of Ksilil is explained by its finer crystalline structure than is of pure cast TNT. As each crystal is supposed to be an "active center", there are more active centers in Ksilil and this increases sensitivity, rate of reaction and evolution of energy in formation of normal detonation regime. If Ksilil is obt'd in coarser crystalline structure as Rus scientist Ya.I. Leitman succeeded in doing, the sensitivity was not higher than for TNT. Leitman also prepd very fine crystalline TNT, Ksilil, RDX, etc) by pptn on slowly pouring the solns into stirred cold water and found that they were more sensitive than corresponding coarser crystalline expls. Not all fine crystals are more sensitive than coarser ones, and there are exceptions. For example, large crystals of some azides (like of LA) are so sensitive that they detonate on touching them. This abnormal behavior is attributed by some scientists to distortion of crystals (Ref 8, pp 59-62 & Ref 9, pp 303-06)

Table 18 given in the book of Baum et al (Ref 8, p 62) gives influence of particle size on sensitivity to initiation of several expls. It is reproduced here as Table I

Table 1

| Explosive | Minimal LA Charge for Initiation, in Grams | |
|-----------|---|--|
| | For particles passing thru sieve with 2500 openings/cm ² | For particles obtained by rapid pptn on pouring the solution into stirred cold water |
| TNXylene | 0.34 | 0.08 |
| TNBenzene | 0.19 | 0.06 |
| TNToluene | 0.10 | 0.04 |

Andreev & Belyaev (Ref 9) give in Table 2, p 305, the following additional information:

Table 2

| Explosive | Minimal LA Charge for Initiation, in Grams | |
|------------------|---|--|
| | For particles passing thru sieve with 2500 openings/cm ² | For particles passing thru sieve with 10000 openings/cm ² |
| TNAniline | 0.13 | 0.05 |
| TNCIBenzene | 0.14 | 0.05 |
| TNBenz Acid | 0.10 | 0.04 |
| TNPhenol | 0.08 | 0.03 |
| TNBenzaldehyde | 0.05 | 0.02 |
| TNMesitylene | 0.43 | 0.13 |
| TNResorcin | 0.04 | 0.02 |
| TNPhloroglucinol | 0.04 | 0.02 |
| TNDCIBenzene | 0.18 | 0.06 |
| TNTCIBenzene | Incomplete deton with 1 g LA | 0.29 |

Physical structure and particle size do not seem to have any effect on sensitivity to shock

g) Density. As a rule sensitivity to initiation decreases with increase of density and this especially noticeable in expl mixts like Ammonites, Cheddites, Chloratites, etc. For densities below certain values, decreases in sensitivity are rather slow, but after this they become quite rapid, as can be seen from Table on p 62 of Ref 8 (our Table 3), where minimum ams of MF required to initiate Cheddite of different densities are given

Some initiating expls (such as MF, DADNPh, TATNB, etc) stop detonating from thermal impulse but can be ignited. This phenomenon, known as "dead-pressing", was

Table 3

| Densities of Cheddite, g/cc | 0.66 | 0.88 | 1.20 | 1.30 | 1.39 | 1.46 |
|-----------------------------|------|------|------|------|------|------|
| Minimum Wt of MF, grams | 0.3 | 0.3 | 0.75 | 1.5 | 2.0 | 3.0 |

investigated after WWII in Russia by Andreyev, Avanesov and Feoktistova. They stated that "dead-pressed" chges can be detonated if they are strongly confined

Sensitivity to shock is only very little affected by changes in density (Ref 8, pp 62-3 & Ref 9, p 31

h) Presence of inert components affects mostly the sensitivity to shock. Some substances which are known as "sensitizers"

increase the sensitivity, while others, known as "phlegmatizers", decrease it. Any pulverized hard material with sharp edges, of melting point higher than explosive to test, can serve as a sensitizer. Rubbing of particles of expl against sharp edges causes excessive friction. As examples of such sensitizers may be cited: glass, sand, quartz, emery, bismuth, etc. Besides the above inert sensitizers, there are also "explosive sensitizers", such as NG, which is usually incorporated in insensitive Dynamites. Phlegmatizers are usually soft substances which can coat particles of expls thus reducing their friction. As examples of phlegmatizers may be cited wax, paraffin, vaseline, liquid glass, clay, glue, etc. Some of the organic inert phlegmatizers can serve as sensitizers when used with insensitive weak expls. For example, thin coating of wax, or paraffin on AN crystals, increases their sensitivity. Some powdered solids of low friction, like talcum, soap, or camphor can also serve as phlegmatizers. For some expls, such as TNT, talcum serves as a sensitizer because its hardness is above that of TNT. However, for RDX talcum serves as a phlegmatizer since it is softer (Ref 8, pp 63-6)

More detailed discussion on detonating capacity of explosives may be found in the following references

Refs: 1) Yu.B. Khariton & S.B. Ratner, DoklAkadN **41**, 293-95 (1943) & CA **38**, 6097 (1944) (Detonation of liquid expls, such as NG & NGc in glass tubes of various diameters) 2) S.B. Ratner, DoklAkadN **42**, 276-78 (1944) & CA **38**, 6097 (1944) (Detonation of liq expls such as Methyl Nitrate in glass tubes of various diameters) 3) A.Ya. Apin, DoklAkadN **50**, 285-88 (1945) & CA **47**, 865 (1945) (Detonation and explosive combustion of explosives) 4) A.Ya. Apin & V.K. Bobolev, ZhFizKhim **20**, 1367-70 (1946) & CA **41**, 3297 (1947) (Effects of physical structure and the state of aggregation on the detonating capacity of explosives) 5) S.B. Ratner, ZhFizKhim **20**, 1377-80 (1946) & CA **41**, 3297 (1947) (The mechanism of deton of liquid expls. An estimation of the temperature rise of liquid nitrates in the shock wave) 6) A.Ya. Apin & V.K. Bobolev, DoklAkadN **58**, 241-44 (1947)

& CA **44**, 7539 (1950) (Character of the detonation break in powdered explosives) 7) Yu.B. Khariton, "On Detonating Capacity of Explosives"; A.F. Belyaev, "Influence of Physical Factors on Stability of Detonation in Ammonium Nitrate Explosives"; Ya.I. Leitman, "Influence of Fineness of Brisant Explosives on Sensitivity to Initiation". Series of papers in Russian, Vol 1 of the book: "Problems of Theory of Explosives", IzdAkadNauk, Moscow (1947) 8) Baum, Stanyukovich & Shekhter (1959), 56-66 (Dependence of sensitivity from various factors) (See our text) 9) Andreev & Belyaev (1960), 302-11 (On influence on sensitivity of physical characteristics of explosives) (It includes: influence of particle size, state of pulverization, state of aggregation, presence of polymorphic forms of crystals and density) 10) K.K. Andreev & S.V. Chuiko, ZhFizKhim **37**, 1304-10 (1963) & CA **59**, 6190 (1963) (Transition of combstn to deflgrn in expls. Combstn of powdered expls at high constant pressures) 11) J. Eadie, "The Effect of Wax on the Shock Sensitivity of Explosive Compacts", 4thONRSympDeton (1965), 399-403 12) J.E. Hay et al, "The Effect of Physical and Chemical Properties on the Sensitivity of Liquid Explosives", 4thONRSympDeton (1965), 412-25 (See also refs under "Detonability and Flammability of Explosives, Propellants and Pyrotechnic Compositions)

Detonating Cord. See Cord, Detonating in Vol 3, p C529-R and Detonating Cord or Fuse in Vol 3, p D103-R

Detonating Cord, Special. See Vol 2, p B17-L under Bangalore Torpedoes

Detonating Explosives. See Vol 3, p D107-L

Detonating Fuse. See Detonating Cord (above)

Detonating Ignition. See Vol 3, p D108-L

Detonating Relays. See Vol 3, p D108-R

Section 2

DETONATION, EXPLOSION AND EXPLOSIVES

Introduction and Definitions

When a loud (thundering) noise is heard and one sees a building, factory, ship, munitions dump on fire or blown up, it is said that an *explosion* took place. This would be correct if the noise were "dull", similar to that heard on firing a cannon, but would be wrong if the noise were "sharp", similar to that heard on bursting of an artillery projectile, bomb, grenade, land mine or torpedo. In this case the term *detonation* would be more appropriate. There is also a kind of noise which is not as loud as that produced on explosion or detonation - it is of a longer duration and sometimes resembles a "hissing" sound produced on firing a rocket. This sound is produced when a large mass of non-confined propellant or blasting explosive catches fire, and the event is known as *deflagration*.

These disasters can be initiated by various means (static electricity, arson, spontaneous combustion of deteriorated expl or proplnt, fire or explosion of a neighboring ship or building, etc). In many cases they are preceded and accompanied by fires. If a fire is not accompanied by a thundering noise and "blowing up" of a building, etc, the event is known as either *burning* (See Vol 2 of Encycl, p B343-L) or *combustion* (See Vol 3, p C425-L). This can take place not only with ordinary combustibles (such as wood, coal, paper, etc), but also with propellants, pyrotechnics or some explosives if they are spread on the ground, wooden boards or concrete in a thin row (band) and ignited from one end. The rate of burning of expls and proplnts is between a few mm and a few cm per second. It is higher for confined substances and sometimes develops into deflagration, explosion or detonation.

Definition of *deflagration* is given in Vol 3 (Ref 10, p D38), to which we might add that its velocity is between that of "combustion" and "low-order detonation", which we prefer to call "explosion". The maximum rate for deflgr given in Vol 3 of Encycl, p D39-L, as 1000-1800 m/sec should

be replaced by 1000 m/sec, because the value 1800 m/sec is too high for a deflagration.

Detonation. There exist two short definitions:

- 1) "Detonation is exploding with sudden violence" (Glossary used at the Naval Ordnance Station, Indian Head, Maryland)
- 2) "Detonation is an extremely rapid and violent explosion"

Both of these definitions are too short and require the knowledge of the meaning of the term "explosion"

The definition of *explosion*, given by Dunkle (Ref 12): "An explosion is a milder form of detonation", although correct, does not help in definition of detonation. For this reason we are giving here a longer definition as taken from MIL-STD-444 (Ref 5a, p 65):

"**Explosion** is a chemical reaction or change of state which is effected in an exceedingly short space of time with the generation of a high temperature and generally a large quantity of gas. An explosion produces a shock wave in the surrounding medium"

This definition applies only to chemical explns and not to physical ones, like "exploding wires". It fails to mention that every expln is accompanied by a thundering noise. This definition is sufficient to clarify the meaning of the term "detonation". A more complete definition of the term "explosion" will be given at the end of this section, pD220-R

Detonation is defined in Ref 5a, p 60 as: "An exothermic chemical reaction that propagates with such rapidity that the rate of advance of the reaction zone into the unreacted material exceeds the velocity of sound in the unreacted material, that is the advancing reaction zone is preceded by a *shock wave*. The rate of advance of the reaction zone is termed *detonation rate* or *detonation velocity*. When this rate of advance attains such a value that it will continue without diminution thru the unreacted material, it is termed a *stable detonation velocity*. The exact value of this term is dependent upon a number of factors, principally the chemical and physical properties of the material. When the detonation rate is equal to or greater than the stable detona-

tion velocity of the explosive, the reaction is termed a *high-order detonation*. When the detonation rate is lower than the stable detonation velocity of the explosive, the reaction is termed a *low-order detonation*. We prefer for this the term "explosion"

To this definition must be added that every detonation is accompanied by a very sharp noise (report), which always accompanies bursting of bombs, artillery shells, mines, grenades, torpedoes, etc.

Before proceeding any further, we include here a brief definition of an "explosive", combining information given in Ref 5a, p 65 and Ref 12:

Explosive is a substance or mixture of substances which may be made to undergo a rapid chemical change without an outside supply of oxygen, with the liberation of large quantities of energy, generally accompanied by the evolution of hot gases or vapors. While a great many substances may be classed as explosives, practically those containing oxygen, nitrogen and oxidizable elements (fuels), such as carbon and hydrogen are used to a great extent. The exceptions are azides, such as LA (PbN_6), and nitrogen compounds, such as iodide (NI_3) and azoimide ($\text{NH}_3 \cdot \text{NI}_3$), which contain no oxygen. In C-H-N-O compds their oxygen is generally attached to nitrogen, as in the group NO , NO_2 , and NO_3 , and on explosion separates therefrom to unite with the oxidizable element. The heat given off is the difference between that required to break up the explosive chemical compd into its elements and that developed on recombination of these elements; or the difference between the heats of formation of the explosive itself and of its products of explosion. Other explosives, however, such as LA are sensitive endothermic compds which readily break up into their elements with generation of heat and do not depend on combined or on ambient oxygen for their explosive effect. Explosives are classed with respect to their rapidity of action and characteristic functioning as *detonating explosives* (See Vol 3, p D107), also known as *high-explosives* or *secondary high-explosives*; *primary explosives*. (formerly called primary high explosives);

low-explosives and *deflagrating explosives* (See Vol 3, p D38-R)

Certain mixtures of fuels and oxidizers can be made to explode and these are considered to be explosives. However, a substance such as a fuel which requires an outside source of oxygen, or an oxidizer which requires an outside source of carbon and hydrogen to explode, is not considered to be an explosive

Some authorities consider that a "primary explosive" is not a "high explosive", but an entirely separate entity (Ref 5a, p 111)

To the above given definitions of detonation may be added the following resumé of material given in the following sources:

Taylor (Ref 1), NOLR 1111 (Ref 2), Rinkenbach (Ref 3, p 293), Cook (Ref 3, p 370 & Ref 5), Dunkle (Refs 2a & 12), Baum et al (Ref 6) and Andreev & Belyaev (Ref 7):

- a) The process of detonation is accompanied by a very loud and sharp sound (report); with spontaneous liberation of enormous amounts of heat, light, gas, and sometimes smoke and electrical current
- b) Detonation may be initiated by mechanical impact & friction or the application of heat, spark or electricity. It may also be initiated by detonation of a second charge, and this is known as "detonation by influence" or "sympathetic detonation". In some cases detonation is preceded by a period of deflagration
- c) Detonation may be considered as a stationary form of explosion. The destructive action of detonation is due to velocity and brisance rather than to power or the 'heaving' action produced on expansion of highly compressed gases evolved in "low-order detonation", which we prefer to call "explosion" (qv). In complete "ideal" detonation (See below) all of the material is being consumed in its own volume, whereas in a "nonideal" detonation there might be some material that is unreacted being dispersed and undergoing a slower decomposition because of being torn away from the main body or becoming incapable of reacting due to loss of confinement
- d) The *ideal detonation* corresponds, accdg to Cook (Ref 5, p 44), to the theoretical maximum or hydrodynamic value of velocity

D*. It is the steady-state value attained at a sufficiently long distance (L) from the initiator in a tube or a charge of diameter sufficiently large that further increase in either the diameter or length will not cause an increase in velocity

e) The *nonideal detonation* refers to detonation in which a long steady-state (long charge length L) wave propagates at a final velocity D lower than the ideal velocity D*

Equations for calcdg D* and some of its values are given on p 45 of Ref 5

f) The supersonic velocity at which a "shock wave" propagates thru an explosive during detonation may reach (as far as is known to us) 9124 m/sec, as was determined for Cyclotetramethylenetetranitramine (HMX) at d 1.84 (See Vol 2 of Encycl, p B270). The lower limit for detonation velocity (high-order detonation) is usually considered 5000 m/sec. Dunkle gives 3500-4000 m/sec which we think is correct for "condensed" expls (See Vol 3 of Encycl, p C495-R), but for gases it should be lower, probably 3000 m/sec. Anything lower than above values is usually considered as "low-order" detonation

g) Solid and liq expls which propagate at velocities above 3500-4000 m/sec are usually considered *detonating or brisant explosives* and are commonly known as *high explosives* (HE's). A conventional way is to separate them into "primary (or initiating) high explosives" and "secondary (or non-initiating) high explosives". This classification, however, is not recognized by some authorities, as found in Notes given in Ref 5a, pp 88-L, 111-L and 127-L. As we do agree with classifications of above mentioned authorities, we use their classification here, but give the old classification for comparison

h) *Primary Explosives*, also known as *Initiating Explosives*, are "detonating" expls extremely sensitive to heat and mechanical action. Their detonation velocities are in the range 3500-5500 m/sec, brisance is comparable to that for secondary expls, but power is lower. They can be easily detonated by one of the following means: heat, flame, spark, impact (stab and percussion), friction, exploding wires and elec-

trical current. Their distinguishing characteristics are the very rapid transition from burning (or deflagration) to detonation and the ability to transmit the detonation to less sensitive expls, such as "booster" expls. For these reasons, they are used in initiating devices, such as igniters, primers, blasting caps and detonators. They can propagate a detonation in extremely small diameter columns. The term "primary" expls is generally used in referring to pure compds, such as MF, LA, LSt, Cyanuric Triazide, Tetracene, etc and not to explosive mixtures. It has been suggested by Bowden & Yoffe (Ref 1a) that primary expls can be defined on the basis that upon slow heating they will decompose explosively while still in the solid state, while secondary expls will melt before undergoing an explosive reaction. This characteristic is true for MF, LA, LSt & Tetracene, but data are not available for all primary expls (Ref 5a, p 111)

i) *Secondary Explosives or High Explosives* (HE's) also known as *Brisant Explosives*, *Detonating Explosives* or *Noninitiating High Explosives*, are less sensitive than primary explosives and hence require considerable energy to initiate them. They are, however, more powerful than primary expls, but their brisance values are comparable. The values of their detonation velocities are in the range of 5500-9000 m/sec. To this class belong a few commercial expls and many military expls

The *commercial* group of high-explosive is represented by the following: Blasting Gelatin (velocity ca 8000 m/sec as listed in Vol 2 of Encycl, pp B211-R & B268), Guhr Dynamite (Vol 2, p B274) with vel 6800 m/sec, 60% Gelatin Dynamite (Vol 2, p B276) with vel 6200 m/sec, 65% Gelatin Dynamite (Vol 2, p B276) with vel 7000 m/sec, Pentritins (Vol 2, p B286) with vels in the range 7200 to 8400 m/sec, Gelatin-Pentrit (Vol 2, p B276) with vel 8000 m/sec and some others

The *military* high explosives may be subdivided into "booster" and "burster" explosives

1) *Booster Explosives* to which may be assigned PA (powdered), Tetryl, RDX, PETN

and HMX, are brisant detonating expls, less sensitive than primary expls but more sensitive than burster expls. Their detonation velocities are in the range 7500-9000 m/sec. Booster expls are sensitive enough to be initiated by detonators alone and for this reason can be used for transmitting detonation from primary to burster expls (See also Vol 2 of Encycl, p B243-R)

2) *Burster (or Bursting) Explosives* are brisant, powerful detonating expls less sensitive than booster expls. Their velocities are in or near the range 5500-7500 m/sec (or even 8000 m/sec) and as examples may be cited Amatols, PA (cast, as "Shimose"), TNT, Compositions A, B & C, Picratol, Tetrytol, etc. They constitute main charges of projectiles, mines, torpedoes, aerial bombs, grenades, etc and require for their initiation a detonator, combined with a booster (See also Vol 2 of Encycl, p B364-L)

j) Dunkle (Ref 2, p 9 & Ref 12) gives a comprehensive description of **detonation process**, which we are repeating here in its entirety:

"The onset of detonation front, which is practically a pressure discontinuity, causes a compression so violent that even a condensed-phase explosive can be compressed to 75-80% of its original volume. The sudden increase in temperature and pressure "shocks" the material into condition to undergo chemical reaction. Even in a condensed-phase material, temperature rises of several hundred degrees at certain critical points ("hot spots") can be brought about in this way. Furthermore, the material ahead of "detonation front" is at rest and since the front is moving at a rate higher than the speed of sound within the undisturbed explosive, there is no way by which "news" of the process can reach the material ahead of the front (except by radiation)

"The high-speed photograph (See Fig) of a detonation propagating down along a stick of an HE at velocity of ca 7500 m/sec shows the very thin detonation front and the rapid expansion of the products starting immediately behind. The photograph shows that the charge of HE ahead of the detonation wave front is undisturbed and at zero velocity

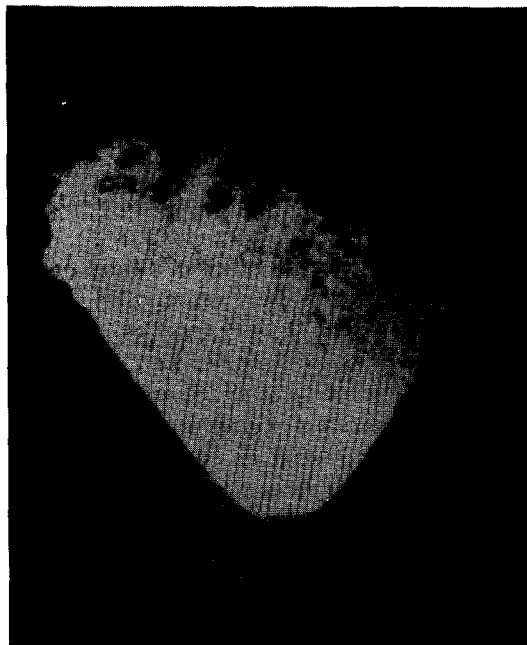

Detonation of High Explosive

until the front reaches it. Immediately behind the front, however, the material has a considerable velocity, D , equal to 1000-1500 m/sec. Thus the intact explosive receives a very vehement mechanical blow when it is struck by the detonation front. This blow is of the same nature as that dealt by the detonation of an initiator. Since it is known that such a blow can start a detonation, it is not surprising that its continual application keeps the detonation going"

Explosion. To the short definition given by Dunkle and to the longer definition given in Ref 5a, p 65, listed at the beginning of this section, the following longer definition of Dunkle may be added: "An *explosion* is the sudden generation of a large quantity of gas usually at high pressure and temperature and with violent effects on surroundings" (Ref 12)

Note 1: This definition, as requiring evolution of gas as a necessary qualification of an "explosion", is evidently referring to a "chemical" expln and not to "physical" expln like "exploding wire", or electrical discharges caused by lightning

Note 2: Dunkle's definition does not include

the fact that every explosion is accompanied by a very loud noise, similar to that produced on firing a cannon (See also pD217-R)

The definitions of Baum et al (Ref 6, p 9) and of Andreyev & Belyayev (Ref 7, p 20) for explosion ("vzryv" in Rus) seem to be all right, except that they do not mention the noise produced on explosion

As none of the definitions satisfies us, we propose the following "composite" definition: **"Explosion** is a process of rapid *physical* or *chemical* transformation of a substance, accompanied by an extremely rapid transition of its potential energy into mechanical work. All this is caused by compression and movement of primary material or its products of decomposition. Each physical explosion (such as "exploding wire") is accompanied by development of exceedingly high heat, whereas each chemical explosion is accompanied also by generation of a large quantity of gas at high pressure and, sometimes, of smoke. Each explosion produces a shock wave in surrounding medium and is accompanied by a very loud noise, reminding one of that heard on firing a cannon but not as "sharp" as produced on detonation of an artillery projectile, bomb, etc"

Besides physical (which includes mechanical and electrical and chemical explosions, there is also atomic (or nuclear) explosion, already described in Vol I, p A501-R (Ref 8)

Following is a description of physical and chemical explosions:

A. Physical Explosions. As examples may be cited the following: bursting of boilers by steam pressure; bursting of a Rus coal blasting device filled with water on suddenly heating it (Ref 3a, p 198 & Ref 10, p C434-L); bursting of coal blasting device "Cardox" filled with liquefied carbon dioxide (Ref 10, p C434-L); bursting of coal blasting device "Airdox" filled with liquefied air (Ref 8, p A117-R); bursting of coal blasting devices, known as Hydraulic Coal Bursters, utilizing water under very high pressure (Ref 10, p C434-R); volcanic eruptions; strong earthquakes; and electrical explosions such as that of air by a lightning discharge, or of a thin wire by a discharge of so much energy

that the metal particles are expelled violently outward. Andreyev & Belyayev (Ref 7, p 21) consider that bursting (with loud report) of closed containers filled with water on sudden freezing, is a "physical explosion", and they describe two disastrous explns which took place sometime ago in Siberia on freezing of water during severe winter

Note 3: Dunkle (Ref 13) does not consider the "bursting of a pipe when water in it freezes" as an explosion, "since there is no generation of gas". The same reasoning he applies to hydraulic bursting. He does not suggest, however, any name to replace "explosion" or such phenomena

Note 4: We would like to mention here that the **implosion** or *bursting inward* is the process opposed to physical explosion. It usually takes place if a vacuum or lower than atmospheric pressure is created inside a container with brittle walls. Implosions can also be caused by hurricanes and tornadoes

Application of physical explosions, while important, are less so than those of the chemical types, described below

B. Chemical Explosions are produced by chemical ("conventional") explosives, propellants or pyrotechnic compositions if they are not in the loose form and unconfined; if they are compressed or cast and in a large quantity piled in one mass, confinement is not necessary to produce an expln. Loose, unconfined materials deflagrate instead of exploding. During a chemical explosion an extremely rapid exothermic transformation takes place resulting in formation of very hot gases and vapors and these are sometimes accompanied by highly divided solid products, such as carbon black or inorganic salts. Due to the extreme rapidity of the reaction (such as one-hundredth of a second), the gases do not expand instantaneously but remain for a fraction of a second inside the volume occupied by explosive charge and are confined within the container. As this space is extremely small, and as the *temperature of explosion* (not to be confused with "explosion temperature") is usually extremely high (several thousands degrees), the developed pressure [See Detonation (and Explosion), Pressure of] is so high (several hundreds

atmospheres) that it is very difficult to measure it accurately by existing experimental methods. It can, however, be determined by calculation. This pressure causes damage and destruction to surrounding objects, and, if the charge is confined, the explosion breaks the wall of container. Destructive action of explosion (as well as of detonation) may extend also to objects located at a distance, if "blast waves" which accompany any explosion (or detonation) are strong enough [See "Blast" in Vol 2 of Encycl, p B180-L (Ref 9)]

Explosives which neither detonate, nor deflagrate, but *explode*, are the so-called *low explosives*. To this class belong most of the *nonmilitary* expls, known as *commercial* or *industrial* expls, which includes coal mining expls (See Vol 3 of Encycl, pp C434-Lff) of which the most important are *Blasting Explosives*, described in Vol 2 of Encycl, pp B202ff (Ref 9) and *Coal Mining Explosives* (Vol 3, pp C437ff) (Ref 10)

Other commercial expls described in our Encycl include: *Agriculture and Forestry Explosives* (Vol 1, p A112-R) (Ref 8), *Ammonium Nitrate Blasting Explosives* (Vol 1, p A341) and *Ammonium Nitrate Dynamites* (Vol 1, p A355)

All commercial expls except some NG & PETN based expls described under "high explosives", are practically non-brisant but possess a rather slow *heaving action*, caused by pressure of evolved gases. They are preferred where it is desired to obtain during blasting large lumps of material, such as in stone quarries, or coal mines. High expls are not suitable for that purpose because they are too brisant and consequently would produce either very small lumps or dust, which would make material unsuitable for the market. *Heaving action* expls propagate with velocity in or near the range 1000 to 3500-4000 m/sec and their power is lower than that for high expls

Explosives possessing velocities below ca 1000 m/sec are known as *deflagrating explosives* (See Vol 3, p D38-R), also known as *burning* or *progressive explosives*. To this class belongs BkPdr (See Vol 2, p B165-R), Nitrocelluloses (See Cellulose Nitrates in Vol 2, p C100-L), smokeless propellants and

pyrotechnic compositions. In these expls burning progresses from the point or surface initially ignited, by the heating of successive layers, to the ignition temperature. Such expls burn on the outside surface only. When in open, or only partially confined, they burn with rates which can be expressed in few centimeters per second (See Vol 2, pp B346 to B355, under Burning). When completely confined or in large bulk they may explode at rates of propagation ranging from 400 m/sec for BkPdr to much higher values when compressed Guncotton is used. Such compressed high N NC can even be used when properly initiated, as bursting charges in shells and torpedoes as, for example, a Rus expl *Slonit*, described in PATR 2145 (1955), p Rus 21. Some brisant or heaving action expls may behave like deflagrating expls when they are spread on the ground in a thin layer (like a ribbon) and ignited from one end. Some HE's can act as low explosives if they are initiated by a weak impulse. For example, NG can propagate with a velocity of only 1600 m/sec at d 1.6 instead of its regular velocity 7700 m/sec and NGc (EGDN) at ca 2050 m/sec at d 1.49 instead of 7300 m/sec

In concluding this write-up we would like to add that, accdg to Baum, Stanyukovich & Shekhter (Ref 6), the main difference between detonation, explosion, deflagration and combustion is in their character of propagation. Combustion and deflagration propagate thru the mass of material by means of thermal conductivity, diffusion and flame, whereas explosion and detonation propagate by means of compression of charge by shock wave

Refs (to Detonation, Explosion and Explosives Definitions): 1) Taylor (1952), pp 1-9 1a) F.P. Bowden & A. Yoffe, "The Initiation of Explosions", UnivPress, Cambridge (1952) 2) Anon, "Ordnance Explosive Train Designers' Handbook", NOLR 1111 (1952), p G1 2a) C.G. Dunkle, "Introduction to Theory of Detonation of Explosives", Lecture delivered at PicArnsn on 13 Dec 1955, pp 1-14 (Definitions of detonation, detonation process and other terms) 3) Clark & Hawley (1957), pp 293-95 ("Detonation", by W.H. Rinkenbach); 370-71 (Explosives and Detonation, by M.A. Cook)

- 3a) Yaremenko & Svetlov (1957), p 198
 4) Dunkle's Syllabus (1957-1958) - could not find definitions of detonation and explosion
 5) Cook (1958), 44-50 (Ideal & nonideal detonations) 5a) Anon, "Nomenclature and Definitions in the Ammunition Area", Military Standard MIL-STD-444 (1959), p 60 (Detonation) & p 65 (Explosion) 6) Baum, Stanyukovich & Shekhter (1959), pp 9 & 15-16
 7) Andreev & Belyaev (1960), pp 20-21
 8) PATR 2700, Vol 1 (1960), pp - as indicated in the text 9) PATR 2700, Vol 2 (1962), pp - as indicated in the text 10) PATR 2700, Vol 3 (1966), pp - as indicated in the text
 11) Clark & Hawley, 2nd edition (1966), 400-402 (Explosives) 12) C.G. Dunkle: private communications, Nov 7, 1967 13) Ditto, Dec 30, 1967

DETONATION AND EXPLOSION

Detonation, Abel Equation of State. See under DETONATION (AND EXPLOSION), EQUATIONS OF STATE IN (AND SOME OTHER EQUATIONS)

Detonation, Abel Theory of or Theory of Synchronous Vibrations. It is the earliest theory (1869). See under DETONATION (AND EXPLOSION), THEORIES, History

Detonation, Ability to Propagate. See "Ability to Propagate Detonation", in Vol 1 of Encycl, p VII

Detonation, Absolute Reaction Rate Theory of Eyring or Activated Complex Theory. See "Absolute Rate Theory" in Vol 1 of Encycl, p A4-R and in Cook (1958), p 134

Detonation, Activated Complex Theory or Transition State Theory. Same as Detonation, Absolute Reaction Rate of Eyring

Detonation, Acoustical Theory of Shock Waves is discussed in the book of Baum Stanyukovich & Shekhter (1959), pp 206-08

Detonation, Advance. See "Advance Detonation" in Vol 1 of Encycl, p A105 and in Dunkle's Syllabus (1960-1961), p 17e

Detonation, After-Jet in Shaped Charges. This phenomenon is discussed by S. Singh in JAppl-Phys 28, 1365-66 (1957). Some evidence is presented which shows that the after-jet is due to the relatively long time taken for the latter stages of collapse and the ductile drawing between the last formed jet and slug elements

The last formed jet and slug elements come from liner elements near the base of the cone. During collapse of the cone, the already-formed front of the jet travels on thru space, drawing thinner all the time, but never losing contact with the portion still being formed

Detonation, After-Reaction in. See Delayed-, After-, or Post-Reactions in Detonation

Detonation, Apin's Theory of. See Detonation, Penetrating- or Jet-Piercing Theory of Apin

Detonation, Atomic (or Nuclear). A brief description is given in Vol 1 of Encycl, p A501-R under "Atomic Energy" and additional information is given in this section under "Detonation, Nuclear"

Detonation; Attenuation, Break, Cessation, Cutoff, Decay, Dying-out, Extinction, Fadeout and Failure

In the opinion of Dunkle (Ref 11), "there seems to be no clear agreement on the meanings of the above terms or on the distinction between them". In his opinion the term *attenuation*, as discussed by Zaidel & Zel'dovich (Ref 10), would be similar to *failure (extinction or dying out)* and indicates a gradual weakening (dwindling) as when waves pass thru a resisting medium. Failure can be caused by some internal property, such as insufficiency of energy release

The *cutoff* observed by Rozing & Khariton (Ref 1) in detonation of explosives in tubes of small diameter and also discussed in the book of Zel'dovich & Kompaneets (Ref 8, pp 213-16) is an *abrupt extinction* of the detonation by rarefaction waves from the sides of the charge reaching the axis before completion of the chemical reaction. It

seems to be identical with *detonation break* reported in Ref 2. In the opinion of Dunkle, "break" and "cutoff" seem to apply better when the detonation is interrupted by some outside influence such as by a gap or a SPHF (Shock-Pass-Heat-Filter), described in Cook's book, pp 83-89 & 187-94. The term "cessation" used in Ref 5, seems to be identical with "break" and "cutoff"

In experiments of Khariton & Ratner (Ref 2) with NG (Nitroglycerin) and NGc (Nitroglycol) initiated in glass tubes of various diameters with No 8 detonator, a *break*, like an "abrupt halt", was observed after propagation thru a length of ca 100 diameters in tubes of less than 5 mm. Only lower order detonation velocity, ca 1800 m/sec, was developed in narrow tubes. On coupling wider and narrow tubes together, the higher DV, ca 7500 m/sec, could be propagated into narrow tubes down to a diam of ca 2.7 mm, but at smaller diams, such as 2 mm, an "abrupt drop" from high DV to the low value was observed. It seems the

"break" observed for NG & NGc was the same phenomenon as "cutoff" discussed in Ref 1 & Ref 8

Ratner (Ref 3) extended investigation of liquid nitrates to MeN (Methyl Nitrate). Using glass tubes of 8 mm and 2.5 mm diam, he observed change of DV from high (6500 m/sec) to low (1500 m/sec) on propagation of detonation from wider to narrow tube. Although the Chemical Abstract does not use the terms "break" or "abrupt halt" as in Ref 2, its description indicates, nevertheless, that results are in complete analogy with those for NG and NGc, as described in Ref 2

Apin & Bobolev (Ref 4) investigated detonation of TNT and reported that propagation stopped for liquid TNT if the diam of sample dropped below 32 mm

Same investigators (Ref 5) observed photographically behavior in detonation of powdered explosives: solid NG (stable form), PETN, RDX & PA. In all the expls tested a detonation "break" was found which appeared

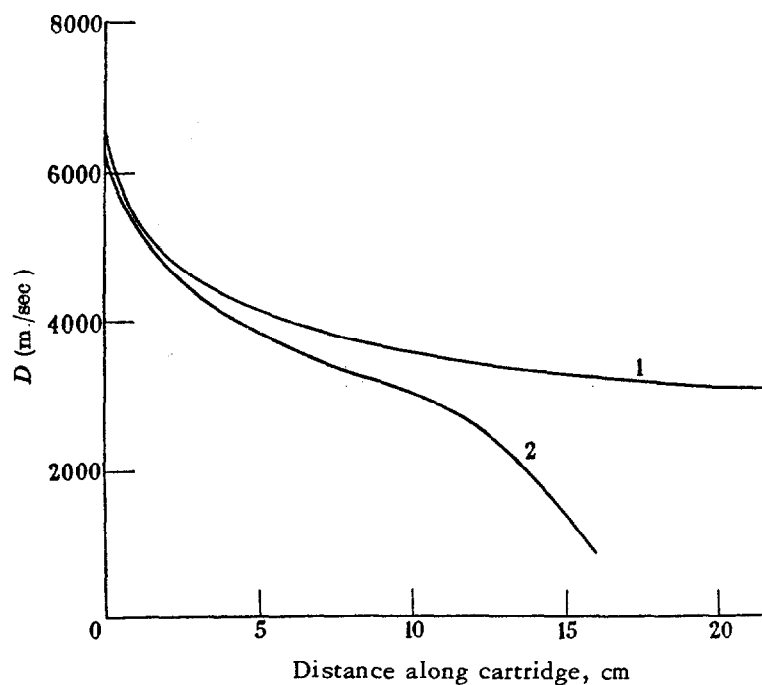

Fig 1 Build-down and Fading of Detonation in Ballistite

on the photographs as a "break" or as small "streaks" in the track of the flame

Gurton (Ref 6) discusses the *fading* of detonation and gives a curve (See Fig 1) showing build-down and fading of deton in Ballistite of density $\Delta = 1.05$ g/cc. Curve 1 is for diameter of cartridge $d = 2.54$ cm and curve 2 for $d = 2.27$ cm

Kistiakowsky (Ref 7) discusses spontaneous "decay" of gaseous shock waves and gives on p 951 three curves giving relationships between pressure of shock wave and distance from shock front (See Fig 2)

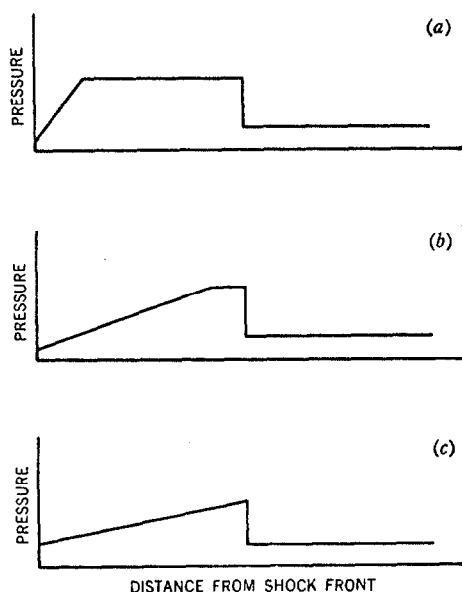

Fig 2 Decay of shock waves: (a) shortly after piston has been stopped; (b) later; and (c) still later, when rarefaction has overtaken shock wave

Erkman describes in Ref 8a, experiments conducted at Poulter Labs, Stanford Research Institute, Menlo Park, Calif, in which Al plates were caused to spall by explosively induced oblique shock waves. The work was principally directed toward developing techniques for performing reproducible experiments with Al and for testing the scaling laws for spalling. During these experiments was also studied *decay* of explosively-induced shock waves in solids

The *failure* of detonation of coal-mining explosives in bore-holes, discussed

by Fukuda (Ref 9) seems to differ from any of the foregoing effect, and refer to a permanent stoppage of the process by shock waves reflected from the surroundings. Maybe the terms "extinction" or "attenuation" applied to the phenomenon observed by Zaidel & Zel'dovich (Ref 10) would be better words for defining the "failure" of detonation

Refs: 1) V. Rozing & Yu.B. Khariton, Dokl-AkadN **26**, 360(1939); CA - not listed (Detonation "cutoff" of expls when the chge diams are small) 2) Yu.B. Khariton & S.B. Ratner, ComptRendAcadSci(Russia)(Dokl-AkadN) **41**, 293-95 (1945) (in Engl); CA **38**, 6097 (1944) 3) S.B. Ratner, DoklAkadN **42**, 276-78(1944) & CA **38**, 6097(1944) 4) Ya.B. Apin & V.K. Bobolev, ZhFizKhim **20**, 1367-70(1946) & CA **41**, 3297(1947) 5) Ibid, DoklAkadN **58**, 241-44(1947) & CA **44**, 7539(1950) (Cessation of detonation in powdered explosives) 6) O.A. Gurton, PrRoySoc **204A**, 31-33(1950) (Fading of detonation in solid expls) 6a) D.W. Woodhead & R. Wilson, Nature **167**, 561(1951) (Fading of deton in cones of expls) 7) G.B. Kistiakowsky, "Theory of Detonation in Explosives", in Kirk & Othmer's Encyclopedia, Vol **5**(1950), pp 951-52 (Spontaneous decay of shock waves) (Not found in 2nd edition of Encycl) 8) Zel'dovich & Kompaneets (1960), p 213-16 8a) J.O. Erkman, "Decay of Explosively-Induced Shock Waves in Solids and Spalling of Aluminum", pp 253-66 in Vol 1 of 3rdONR-SympDeton (1960) 9) H. Fukuda, Kôgyô-KayakuKyôkaishi **22**, 71-82(1961) & CA **59**, 6189-90(1963) 10) R.M. Zaidel & Ya.B. Zel'dovich, ZhPriklMekhan i TekhnFiz **1963** (6), pp 59-65 & CA **60**, 14325(1964) (One-dimensional instability and attenuation of detonation) 10a) Mary L. Pandow et al, "Studies of the Diameter-Dependence of Detonation Velocity in Solid Composite Propellants. II. Prediction of Failure Diameters", 4thONRSympDeton(1965), 102-06 11) C.G. Dunkle, private communication, Silver Spring, Md, August 12, 1968

Detonation (and Explosion), Autocatalytic.

Under this term are known explosive reactions which are accelerated by the action of cata-

lysts. These catalysts are either present in the explosive itself or are formed during the reaction. In the latter case the rate of reaction accelerates as long as the quantity of catalyst increases in products of reaction and then reaches a certain maximum. After this acceleration decreases and finally drops to zero

Mathematical development of autocatalytic explosions is given in Refs 1 & 3

Cook (Ref 1), in describing thermal decomposition of some HE's conducted in the quartz spring apparatus (described in Ref 1, p 175 and shown there in Figs 8.1a & 8.1b), stated that PETN, RDX, Tetryl and to a small extent TNT decomposed autocatalytically. EDNA followed the first-order decomposition law only until about 5% of the explosive had decomposed and then the reaction stabilized. The term *autostabilization* was applied here on the supposition that one of the condensed decomposition products of EDNA which accumulated in the explosive apparently tended to stabilize the bulk of expl and thus slow down the decomposition. After about 10% of the expl had decompd, however, the "autocatalysis" developed. No other expl examined by Cook et al (up to 1958) exhibited the "autostabilization" effect, as did EDNA (Ref 1, pp 175-78). Fig 8.3, p 176 of Ref 1 shows the curves of first-order followed by autostabilization isothermal decomposition in EDNA at different temperatures; and Fig 8.4, p 177 shows the curves autocatalyzed isothermal decomposition of PETN at different temperatures

Refs: 1) Cook (1958), 175-78 2) Dunkle's Syllabus (1957-1958) - (No discussion on "autocatalysis", but on p 140 is mentioned the "activated complex", which is an important agent in catalysis) 3) Andreev & Belyaev (1960), pp 57-61 (Avtokataliticheskii Vzryv) (Autocatalytic Explosion)

Detonation (and Explosion), Available Energy. See under "Detonation (and Explosion), Power, Available Energy (or Maximum Available Work Potential) and Strength in"

Detonation; BMPT (Birkhoff-MacDougall-Pugh-Taylor) Theory of Jet Formation in Shaped Charges

The hydrodynamic mechanism of jet formation of BMPT is best applied to a wedge liner. As the deton front strikes the liner, a shock wave is induced in the metal causing the liner wall to compress. The wall collapses towards the axis. When the flow of metal arrives at the axial region, the resulting collision divides the flow into two jets. The larger part goes backward to form a slug, the smaller part goes forward into the main jet. BMPT assumed that the deton wave will transfer its momentum to the liner in a short time relative to the time of elapse, and that the walls will then flow towards the axis at a constant velocity

BMPT theory accurately predicted that the slug and forward jet would have exactly the same length

A fuller explanation of the BMPT theory and their equations defining liner collapse & jet formation is found in Cook (Ref 2)
Refs: 1) G. Birkhoff, D.P. MacDougall, E.M. Pugh & G. Taylor, *JApplPhys* **19**, 563-82 (1948) 2) Cook (1958), 244-47

Detonation, Break of. See under "Detonation; Attenuation, Break, Cutoff, Decay, Dying out, Extinction, Fading and Failure of

Detonation (and Explosion), Break Character of.

Khariton & Ratner (Ref 1) observed by rapid photography methods (such as described in Vol 2 of Encycl under CAMERAS), that detonation of NG in a tube smaller than 5 mm diameter came to an abrupt halt after propagating thru a length of ca 100 diameters. The same phenomenon of detonation break was observed with NGc. Apin & Bobolev (Ref 2) extended the investigation to solid expls, such as PETN, RDX & PA (in powdered form) and to the frozen NG (stable form crysts). For all the expls tested in small diam tubes, the photographs showed either breaks, similar to those described in Ref 1, or a series of small streaks in the track of the flame. These investigators also showed that the course of detonation is very complicated

and depends on the grain size of an expl, its density, and diameter and length of the charge

Refs: 1) Yu.B. Khariton, DoklAkadN **41**, 293-95 (1943) & CA, **38**, 6097 (1944) 2) A.Ya. Apin & V.K. Bobolev, DoklAkadN **58**, 241-44 (1947) & CA **44**, 7539 (1950)

Detonation (and Explosion), Breaking Theory of Carl.

In addn to a brief abstract given in Vol 2, p B262, we are including the following description, because it seems that this theory has some merit, although Mr Dunkle thinks that it is of interest merely for historical purposes. This theory was not fully developed on acct of untimely death of Mr. R. Carl, formerly of Picatinny Arsenal and the US Bureau of Mines

1) Detonation is the progressive breaking of the valence bond by a stress, known as *breaking stress*, which is transmitted thru the material as an elastic wave similar to a sound wave. This wave may be considered of such intensity as to destroy structure of the material and this distinguishes it from a sound wave. There is no to-and-fro movement of particles as experienced during passage of a sound wave because the return (reciprocal) motion of the particles carried forward by the wave in detonation is prevented by the break-down or collapse of the material. It is also prevented by the extremely high pressure produced behind the crest of the wave by the recombination of the elements which had constituted the expl. Then, with compression in front of it and a rarefaction behind it the layer of air is brought to rest and may even start to move backwards

2) The transmission of such a stress will depend on the elastic nature of the material, and the optimum condition for transmission of the breaking wave is achieved in perfectly elastic materials, such as individual crystals. The soft, plastic or fluid materials which tend to damp out elastic waves have a similar tendency with detonation wave

3) The energy which maintains the breaking wave is the release of gases and heat, behind the wave crest, so that there is continuous

compression instead of compression and rarefaction of the ordinary sound wave

4) The source of such a *breaking stress* may be release of strains already existing in the materials, nevertheless some assistance from an outside force is usually required. Such strains exist in endothermic compds, such as most initiating or primary expls. The initiating impulse for this type of compd may be a rise of temp, impact, friction, the breaking of a crystal, or even allowing its surface to become dry

5) The destructive stress of initiating expls may be applied to any expl material, but will be transmitted only to a limited extent in materials which do not release energy in sufficient quantity or intensity to maintain it

6) The stress which is transmitted and which causes the disruption of the material is not the expln, nor the direct cause of the expln, but merely the disturbance which releases the bonds betw the atoms of the expl compd, thus allowing them to recombine, in a more stable form with release of energy. In this release is found the distinction betw the endothermic and exothermic compds. The endothermic compds possess a large part of their energy in their structure, and release this energy almost instantaneously upon destruction of the form. This property makes them effective as initiators of deton. These expls (such as MF, LA, LSt etc) are known as *primary high explosives* to distinguish them from exothermic compds, known as *secondary high explosives* (such as TNT, Tetryl, PETN, RDX, etc). The exothermic compds require the expenditure of energy for the destruction of their form and derive a larger part of their energy from the recombination of their elements in a more stable condition

7) The speed of the breaking wave has no relation to the violence of the reaction which follows, but is mainly controlled by the physical condition of the medium. Extreme violence of reaction following the wave may cause a somewhat higher rate in the same way, that the rate of a very intense sound wave is increased above normal sound velocity. The violence of the reaction following

the wave is dependent almost entirely upon the chemical nature of the material left by the wave, or the products of detonation. These products must be distinguished from the final products which result from the complete reaction, and which Carl calls the *products of explosion*

8) The distortion which brings about the breaking carries a portion of the material forward and because of the intense pressure generated behind the wave, the reciprocal movement of the medium is prevented. The forward movement of the medium and the prevention of counter-movement serve to increase the speed of the wave front. This effect explains the fact that the *rate of detonation increases more rapidly with increase of density in an insensitive than in a sensitive explosive*. The insensitive material must be distorted and moved forward to a greater extent than the sensitive material before rupture occurs

9) When the rates of deton are plotted against densities, approx straight lines can be obtained when the interfering factor (such as impurity, confinement, differences in granulation, etc) are considered. A straight line is also obtd when the rate of sound thru expl materials is plotted against density

10) Two factors act to cause higher rates of deton at higher densities: first, the increased rate of sound thru expls at higher d's and, second, the effect of distortion of the material, which causes the expl to move in the direction of the progress of the wave, thereby advancing the wave by a definite increment, which varies with each expl. The forward movement of the material due to the distortion is non-reciprocated. All this causes the collapse of molecules and the energy for the continuation of the wave is furnished by the gases and heat liberated by the break-down or by recombination of the elements after the break-down.

11) Carl gives the following formula for the straight line representing the rates of detonation:

$$y = (a + a')x + b$$

where $a = \text{constant}$ by which the rate of sound increases with increased d ; $a' = \text{constant}$ by

which the collapse of the molecule increases the rate thru expl and $b = \text{constant}$. The value $(a + a')$ is sufficiently significant to distinguish the sensitive from insensitive expls. See table giving values of $(a + a')$, b and SpGr

Table

| Explosive | $(a + a')$, m/sec | b m/sec | SpGr g/cc |
|----------------------------|-----------------------|--------------|--------------|
| Amm Picrate | 71.82 | 380 | 1.71 |
| Gu Picrate | 65.33 | 735 | 1.70 |
| TeNA | 62.93 | 2065 | 1.84 |
| PA | 58.52 | 1815 | 1.76 |
| TNT | 57.34 | 1365 | 1.65 |
| Tetryl | 50.17 | 2685 | 1.72 |
| MF | 31.91 | 1795 | 4.42 |
| 80/20-MF/KClO ₃ | 45.40 | 940 | 4.00 |
| 90/10-MF/KClO ₃ | 37.34 | 1365 | 4.21 |

12) The sensitivity of expls is a characteristic of great importance and can be correlated with the rate of deton. Perfect crystals and other nearly perfect elastic materials are the most sensitive, while liquids or colloids (plastic, fluid or hard) resist initiation and also have tendency to damp out the wave of deton. The sensitivities of endothermic and exothermic compds are different and this causes them to react oppositely to certain changes. For example, increased crystal size causes increased sensitivity in endothermic compds and decreased sensitivity in exothermic compds. The destruction of the crystal form of endothermic compds is accompanied by an instantaneous release of energy

13) The power and brisance of expls do not depend upon the rate of deton but rather on the energy of formation of expl and the energy of recombination of products of deton. The different valence bonds of the same compd may be of different sign in respect to their heat of formation

14) As the materials which conform best to the laws of deton are perfect crystals, any theoretical study of the laws governing the phenomenon of deton must be conducted using perfect crystals if they are available (Ref 1, pp 356-66)

Examples of application of Carl's theory to various expls were given on pp 366-73 of Ref 1

Refs: 1) L.R. Carl, JFranklInst **230**, 207-27 & 355-74 (1940) 2) Dunkle's Syllabus (1957), 14; Ibid (1958), 137

Detonation from Burning, Transition of. See under Detonation (and Explosion) Development (Transition) from Burning (Combustion) or Deflagration and the following paper by A. Maček, "Transition from Slow Burning to Detonation. A Model for Shock Formation in a Deflagrating Solid", NOLNavOrd Rept **6105** (1958) [See also Andreev & Belyaev (1960), 141-44]

Detonation, Carry-Over Distance in Sympathetic Detonation. The term "carry-over distance" is used by Evans in the examination of phenomenon called by him "Transition of Detonation". It is not the same as the term gap used in Detonation by Influence Ref: W.M. Evans, "Some Characteristics of Detonation", PrRoySoc **204A**, pp 16-17 and Figs 6 to 13, incl

Detonation, Cavity-, Hollow Charge or Shaped Charge Effect. See under DETONATION, MUNROE-NEUMANN EFFECT

Detonation, Cessation of. See under Detonation; Attenuation, Break, Cessation, Cutoff, etc

Detonation, Cessation of (in Powdered Explosives) was discussed by A.Ya. Apin & V.K. Bobolev in DoklAkadNauk **58**, 241-44 (1947)

Detonation (and Explosion), Chain Reactions in.

To the brief description given in Vol 2 of Encycl, p C146-L, the following may be added:

Andreev & Belyaev (1960), 61-99 gave a comprehensive description of the theory. Accdg to them the first indication on existence of chain reactions was done by A.N. Bach in 1897 and then by H.A. Shilov in 1905, but the principal work on development of the theory was done by N.N. Semenov. His book in English was listed as Ref 1 on the bottom of p C146-L in Vol 2, while his book in Rus is entitled: "O Nekotorykh Problemakh Khimicheskoy Kinetiki i Reaktsionnoy Sposobnosti"

(Concerning Some Problems of Chemical Kinetics and Reactiveness), AN SSSR (1958) (See also Dunkle's Note, which follows) Note (Dunkle's communication, Jan 1968) was as follows:

"In my APL Report BBW/CGD/TR-11, on my trip to the Eleventh symposium on Combustion, there is a discussion of chain reactions in explosion on pages 17-19, and a comparison of the chain-reaction theory with the thermal theory on pages 19-23

"Under this heading you might add something like the following excerpts from pages 17-21:

"Explosion may occur as the result of a chain reaction, when the reaction of a "chain carrier", such as a free atom or radical, with a molecule frees another such particle to continue the chain, for example, $\cdot\text{OH} + \text{H}_2 \rightarrow \text{H}_2\text{O} + \text{H}\cdot$. Particularly effective is a branching chain reaction, such as $\text{H}\cdot + \text{O}_2 \rightarrow \cdot\text{OH} + \cdot\text{O}\cdot$, so called because the disappearance of one chain carrier leads to the appearance of two. If chain carriers are produced at a rate faster than they are removed (by chain-breaking or chain-terminating reactions), a branching-chain explosion can occur without any preliminary temperature rise at all (hence "isothermal")

"Such reactions have been used to explain the three limits found in some oxidation reactions, such as those of hydrogen or of carbon monoxide with oxygen, with an "explosion peninsula" between the lower and the second limit. However, the phenomenon of the explosion limit itself is not a criterion for a choice between the critical reaction rate of the thermal theory and the critical chain-branching coefficient of the isothermal-chain-reaction theory (See Ref). For exothermic reactions, the temperature rise of the reacting system due to the heat evolved accelerates the reaction rate. In view of the subsequent modification of the Arrhenius factor during the development of the reaction, the evolution of the system is quite similar to that of the branched-chain reactions, even if the system obeys a simple kinetic law. It is necessary in each individual case to determine the reaction mechanism from the whole

of the experimental data"

Ref: B. Lewis & G. von Elbe, "Combustion, Flames and Explosions", 2nd Ed, Academic Press, NY (1961), p 15

Detonation, Chapman-Jouguet (CJ) Condition

An expl material (solid, liq or gaseous) on proper initiation moves from right to left at deton velocity and passes into the deton zone which is stationary in space. Conditions thruout the deton zone are steady. The tremendous increase in thermal motion of the atoms or molecules as they pass into the shock zone causes chemical reactions of great rapidity. When the expl products reach the end of the reaction zone they are in chem equilibrium. They can be maintained at these conditions if they are contained by a piston which moves uniformly to the left at the same speed at which the products emerge from the reaction zone. This speed is identical with the local velocity of sound in the gaseous products (See Fig 1 from Ref.1)

See also Detonation, Chapman-Jouguet Theory and also under Detonation, Theories of

Its investigation by the "Inverse Method" is discussed by W.W. Wood & W. Fickett in Physics of Fluids 6, 648-52 (1961)

Refs: 1) W.G. Penney, ProcRoySoc 204A, 3-4 (1950) 2) Taylor (1952), 73ff

Detonation, Chapman-Jouguet (and Deflagration)

A process in which the velocity of the combustion products is exactly sonic at the equilibrium temperature and pressure of the products (CJ condition), and the velocity of the front relative to the undisturbed medium ahead is supersonic. (The same considerations apply

to a CJ Deflagration except that the velocity of the front is subsonic)

Detonation, Chapman-Jouguet (in Gas). Criterion of instability of C-J deton is derived mathematically, assuming an ideal gas, by S.K. Aslanov, DoklAkadNauk 163(3), 667-70 (1965) & CA 63, 9736(1965)

Detonation, Chapman-Jouguet Hypothesis. See Detonation, Chapman-Jouguet Postulate

Detonation, Chapman-Jouguet Isentrope. A line on the plot of P vs V or other thermodynamic coordinates at constant entropy and under CJ condition. W.A. Walker & H.M. Sternberg [4thONRSympDeton(1965), pp 27-38] investigated the form of the CJ isentrope of Pentolite (50/50 PETN/TNT) by comparing the results of hydrodynamic calculations of the underwater performance of spherical chges with existing experimental data

Detonation, Chapman-Jouguet Layer. See under Detonation, Chapman-Jouguet Point

Detonation, Chapman-Jouguet Parameters or Chapman-Jouguet Variables. Parameters are properties, or thermodynamic coordinates of the reaction products at equilibrium or completion of the reaction. These parameters are denoted by subscript CJ, like in P_{CJ}

Dunkle calculated [Applied Physics Laboratory Rept BBW/CGD/M-13, 1965 (Johns Hopkins Univ, Silver Spring, Md)], many Chapman-Jouguet parameters for various single explosive compounds and explosive

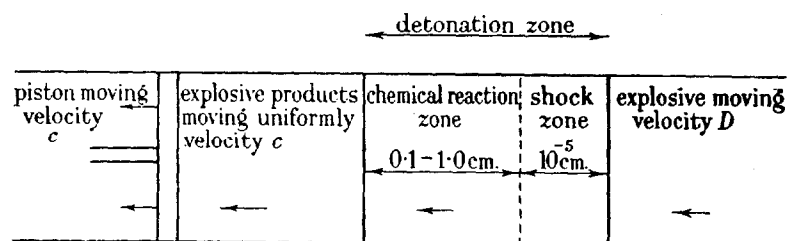

FIGURE 1 Steady plane detonation in a solid explosive. The detonation zone is reduced to rest by making the explosive feed into the detonation zone from right to left at the detonation velocity D

mixtures. Some of his values have been selected for inclusion in the Table of CJ Parameters

Note 1. The product $(\rho_0/D) \cdot (dD/d\rho_0)$ has no name. It signifies the proportionate increase in D for a given proportionate increase in ρ_0 , and hence is the slope of the dimensionless D/ρ_0 curve

Note 2. The term $P(\partial V/\partial E)_P$, where P is pressure of gas; V - its volume and E specific energy, might be considered as a measure of gas imperfection of the detonation products, since for an ideal gas ($E=RT$), this term would be unity

Note 3. When the term Chapman-Jouguet (C-J) is used to denote a given pressure, particle velocity, temp, etc, it means the values of these parameters at the *Chapman-Jouguet plane*, which accdg to the classical NDZ (von Neumann-Döring-Zel'dovich) theory is the rear boundary of the reaction zone. The polytropic exponent γ is the exponent in the "polytropic" or "gamma-law" equation of state, $PV^\gamma = \text{a constant}$ (See item (w) under Detonation, Equations of State) (Dunkle's letter of April 16, 1968)

Note 4. Calculation of Chapman-Jouguet detonation pressure was done using the equation derived by Cook. It is written by Dunkle as:

$$P_{CJ} = 0.01 \rho_0 D^2 \left(0.38 - \frac{1270 \rho_0}{D \rho_c} \right)$$

where D - detonation velocity; ρ_0 - loading density; and ρ_c - crystal density

Dunkle pointed out that the highest loading densities (ρ_0) for which parameters are listed in his Table are always lower than corresponding crystal densities (ρ_c). For example: for RDX, $\rho_c = 1.816$ and $\rho_0 = 1.80$, PETN 1.77 vs 1.69, Tetryl 1.73 vs 1.62, TNT 1.654 vs 1.640, Comp B 1.748 vs 1.72 and 50/50 Pentolite 1.710 vs 1.682

More information on the subject of parameters is given under "Detonation Parameters". Among the refs cited there, the most important is that of C.L. Mader, "Detonation Properties of Condensed Explosives Computed Using the Becker-Kistiakowsky-Wilson Equation of State", Los

Alamos Scientific Laboratory Rept LA-2900 (1963). Table III, pp 14-17 of this report lists the following CJ parameters: D , P , T & γ for several pure expls and mixtures. Some of these are included in the table which contains CJ parameters, as taken from various sources

Detonation, Chapman-Jouguet Particle Velocity. It is one of the CJ Parameters and its values are listed in the Table under Detonation, Chapman-Jouguet Parameters

Detonation, Chapman-Jouguet Plane and Chapman-Jouguet Layer. See under Detonation, Chapman-Jouguet Point

Detonation, Chapman-Jouguet Point

This is the point in the reaction zone at which the *CJ Condition* applies. Since the cross section of an actual chge is always of a finite area, the locus of points at which the condition applies is a plane, called the *CJ Plane*, or other surface, *CJ Surface*. If the CJ condition applies thruout a region of finite thickness, even though small, the more appropriate term is *CJ Layer*. The determination of the CJ Point for HMX/Inert (95/5) & for HMX/TNT/Inert (68/30/2) is reported by J.W.S. Allan & B.D. Lambourn in the 4th ONR Sym Deton (1965), p 55

Detonation, Chapman-Jouguet Postulate or Chapman-Jouguet Hypothesis. The CJ postulate, [according to Cook (1958), p 66], rests entirely on the fact that it agrees with experimental observations. No complete theoretical proof of it has been given. However, the same considerations which led to the adoption of this postulate exist for the laws of thermodynamics

See Detonation, Chapman-Jouguet Theory and also under Detonation, Theories of

Detonation, Chapman-Jouguet Pressure. It is one of the CJ parameters, some values of which are listed in the Table under Detonation, Chapman-Jouguet Parameters

The CJ pressures of RDX, TNT, 64/36

**Table
Chapman-Jouguet Detonation Parameters**

| Explosive | Chge Prepn | Loading Density g/cc ρ_0 | Chapman-Jouguet Detonation Velocity D* in km/sec | | Chapman-Jouguet Particle Velocity km/sec U_{CJ} | Product $\rho_0 \cdot \frac{dD}{D \cdot d\rho_0}$ See Note 1 | Shock Velocity in H ₂ O U_{H_2O} km/sec | Shock Pressure in H ₂ O $P_{s(H_2O)}$ km/sec | Chapman-Jouguet Pressure, P_{CJ} kbar | | Polytropic Exponent, γ Note 3 | Term $\left(\frac{\partial V}{\partial E}\right)_P$ See Note 2 | Temperature of Detonation T°K | |
|--|------------|-------------------------------------|---|------------|---|---|--|---|--|--------------------------|--|---|----------------------------------|---------------------------|
| | | | Exptl | Calcd | | | | | Exptl | Calcd Note 4 | | | Chapman-Jouguet Calcd | Exptl |
| | | | ALEX-20 (RDX 44, TNT 32 Al 19.8 & Wax 4%) | Solid | | | | | 1.801 | 7.53 | | | 7.671 | - |
| ALEX-32 (RDX 37.4, TNT 27.8, Al 39.8 & Wax 4 parts) | Solid | 1.880 | 7.30 | 6.971 | - | - | - | - | 215 | 211 | 3.33 | - | 6340 | - |
| ALEX-? (RDX/TNT/Al -45/30/25) | Solid | 1.82 | 6.76 | - | - | - | - | - | - | 150 | - | - | 5700 | - |
| Amatol -50/50 | Solid | {1.0 1.55 | 5.100 - | - 7.383 | - | - | - | - | - | 45 139 | - | - | 3310 3550 | - |
| Ammonium Nitrate (AN) | Solid | {0.82 1.30 | 3.490 5.270 | - - | - | - | - | - | - | 25 70 | - | - | - | - |
| AN/Al-80/20 | Solid | 1.27 | 6.4 | - | - | - | - | - | - | 132 | - | - | 4990 | - |
| Baratol [Ba(NO ₃) ₂ 73 & TNT 27%] (NC added) | Cast | 2.528 | 4.990 | - | - | 0.9057 | 4.475 ± 0.021 | 72.60 | 132.8 | - | 3.739 | 0.4866 | - | - |
| Benzene-TenMe (Mole Ratio) | Liquid | 1.362 | 6.85 | 6.948 | - | - | - | - | - | 182 | 2.60 | - | 3520 | 3700 |
| Composition B (RDX 59.5, TNT 40.5 & Wax added) | Cast | 1.668 | 7.860 | - | - | 0.6706 | 6.226 | 174.1 | 264.1 | - | 2.801 | 0.2746 | - | - |
| Cyclonite (RDX) | Pressed | 1.630 | 8.341 | - | 2.41 ($\rho_0=1.755$) | 0.7016 | 6.375 | 185.1 | 283.7 | 265 ($\rho_0=1.60$) | 3.015 | 0.3491 | 5070 ($\rho_0=1.60$) | 5136 ($\rho_0=1.60$) |
| Ditto | Pressed | 1.80 | 8.59 | 8.584 | - | - | - | - | 341 | 338 | 2.92 | - | - | - |
| Cyclotol, 50/50 | Cast | 1.627 | 7.660 | - | - | - | 5.916 | 152.3 | 231.1 | - | 3.131 | - | - | - |
| Ditto | Pressed | 1.68 | 7.65 | - | 2.07 | - | - | - | 266 | - | - | - | - | - |

| Explosive | Chge Prepn | Loading Density g/cc ρ_0 | Chapman-Jouguet Detonation Velocity D* in km/sec | | Chapman-Jouguet Particle Velocity km/sec U_{CJ} | Product $\frac{\rho_0}{D} \cdot \frac{dD}{d\rho_0}$ See Note 1 | Shock Velocity in H ₂ O U_{H_2O} km/sec | Shock Pressure in H ₂ O $P_s(H_2O)$ km/sec | Chapman-Jouguet Pressure, P _{CJ} kbar | | Polytropic Exponent, γ Note 3 | Term $P \left(\frac{\partial V}{\partial E} \right)_P$ See Note 2 | Temperature of Detonation T°K | |
|--|-------------|-------------------------------------|---|-------|---|---|--|---|---|-----------------|--|---|----------------------------------|-------|
| | | | Exptl | Calcd | | | | | Exptl | Calcd Note 4 | | | Chapman-Jouguet Calcd | Exptl |
| | | | | | | | | | | | | | | |
| DINA (Diethanol-nitramine Dinitrate) | Liquid | 1.430 | - | 7.469 | - | - | - | - | 217 | 2.68 | - | 2960 | 3480 | |
| DNT | Semi-Liquid | 1.0 | - | - | - | - | - | - | 45 | - | - | - | 3000 | |
| EDNA (Ethylene-dinitramine) | Pressed | 1.532 | 7.639 | - | - | 0.6568 | 6.462 | 191.8 | 265.9 | - | 2.375 | 0.370 | - | - |
| | | 1.710 | - | 8.391 | - | - | - | - | - | 231 | - | - | - | 4300 |
| EDNATOL (50/50) | Solid | 1.530 | 7.180 | - | - | - | - | - | - | 170 | - | - | - | - |
| EGDN (Ethylene glycol Dinitrate) | Liquid | 1.5 | 7.40 | 7.50 | - | - | - | - | - | 200 | - | - | 5090 | 4400 |
| Ethyldecaborane & Tetranitromethane (Mole ratio) | Liquid | 1.40 | 6.74 | 6.849 | - | - | - | - | 172 | 192 | 2.42 | - | 5180 | 4460 |
| | | 1.427 | 6.82 | 6.825 | - | - | - | - | 167 | 194 | 2.42 | - | 5240 | - |
| Ethyldecaborane & Tetrafluorodinitroethane (Mole ratio) | Liquid | 1.467 | 6.91 | 6.620 | - | - | - | - | 206 | 185 | 2.47 | - | 4500 | - |
| Lead Azide (LA) | Solid | 4.0 | 5.100 | - | - | - | - | - | - | 250 | - | - | 5600 | - |
| | | 4.8 | - | - | - | - | - | - | - | 360 | - | - | - | - |
| Mannitol Hexa nitrate (MH) | Solid | 1.7 | - | - | - | - | - | - | - | 300 | - | - | 6040 | - |
| Mercuric Fulminate (MF) | Solid | 4.0 | 5.050 | - | - | - | - | - | - | 220 | - | - | 6910 | - |
| | | 4.41 | - | - | - | - | - | - | - | 264 | - | - | 6000 | - |
| Nitroglycerin (NG) | Liquid | 1.6 | 7.65 | 7.63 | 2.06 | - | - | - | 253 | 256 | 2.61 | - | 3270 | 3470 |
| Nitromethane (NMe) | Liquid | 1.128 | 6.29 | 6.871 | - | - | - | - | 130 | 151 | 2.53 | - | 2960 | 3380 |
| | | 1.14 | 6.30 | - | 1.80 | - | - | - | 129 | - | - | - | - | - |

| Explosive | Chge Prepn | Loading Density g/cc ρ_o | Chapman-Jouguet Detonation Velocity D* in km/sec | | Chapman -Jouguet Particle Velocity km/sec U_{CJ} | Product $\frac{\rho_o}{D} \cdot \frac{dD}{d\rho_o}$ See Note 1 | Shock Velocity in H ₂ O U_{H_2O} km/sec | Shock Pressure in H ₂ O $P_s(H_2O)$ km/sec | Chapman-Jouguet Pressure, P _{CJ} kbar | | Poly- tropic Expo- nent, γ Note 3 | Term $P \left(\frac{\partial V}{\partial E} \right)_p$ See Note 2 | Temperature of Detonation T°K | |
|---|---------------|--|---|------------|---|---|--|---|--|-------------------------------|---|---|-------------------------------------|--------------------------------|
| | | | Exptl | Calcd | | | | | Exptl | Calcd Note 4 | | | Chapman -Jouguet Calcd | Exptl |
| | | | | | | | | | | | | | | |
| NMe-TenMe (Mole Ratio) | Liquid | 1.310 | 6.88 | 7.177 | - | - | - | - | 156 | 195 | 2.46 | - | 3850 | 3750 |
| Pentaerythritol Tetranitrate (PETN) | Pressed | { 1.538 1.568 | 7.675 7.794 | - - | - - | 0.7915 0.7947 | 5.929 6.062 | 153.2 162.3 | 224.7 239.9 | - 226 ($\rho_o=1.6$) | 3.032 2.970 | 0.2506 0.2123 | - 5280 ($\rho_o=1.60$) | - 5684 ($\rho_o=1.56$) |
| Pentolite (50/50) | Cast | { 1.627 1.682 | 7.660 7.662 | - - | - - | - 0.6959 | 5.914 6.053 | 152.3 161.5 | 231.1 245.5 | - 200 ($\rho_o=1.66$) | 3.131 2.925 | - 0.3717 | - - | - - |
| Picric Acid (PA) | Solid | 1.6 | 7.160 | - | - | - | - | 182 | - | - | - | - | - | - |
| Tetryl | Pressed | 1.614 | 7.581 | - | - | 0.6866 | 5.866 | 150.3 | 226.4 | - | 3.101 | 0.4292 | 4700 ($\rho_o=1.6$) | 4837 |
| Tetrytol, 65/35 | Solid | 1.679 | 7.540 | - | - | - | - | - | - | 201 | - | - | - | - |
| TFENA (Trifluoro- ethylnitramine) | Liquid | 1.523 | 6.65 | 6.176 | - | - | - | - | 174 | 164 | - | - | 1950 | - |
| TFNA (1,1,1-Tri- fluoro-3,5,5-trini- tro-3-azahexane) | Solid | 1.692 | 7.40 | 7.387 | - | - | - | - | 249 | 247 | - | - | 2300 | - |
| TFNA/RDX (35/65) | Solid | 1.754 | 8.22 | 8.12 | - | - | - | - | 324 | 298 | 2.88 | - | 2530 | - |
| Trinitroanilin- Nylon (95/5) | Solid | 1.617 | 7.000 | - | - | 0.6588 | 5.245 | 112.2 | 175.2 | - | 3.580 | 0.7263 | - | - |
| Trinitrobenzene (TNB) | Solid | 1.644 | 7.269 | - | - | 0.6450 | 5.835 | 146.9 | 219.2 | - | 2.964 | 0.4090 | - | - |
| Trinitrotoluene (TNT) | Pressed | { 1.59 1.622 | 6.94 6.790 | - - | 1.83 | - 0.7704 | - 5.532 | - 127.6 | 202 - | 154 187.2 | - 2.994 | - 0.2564 | - - | - - |
| | Cast | 1.640 | 6.95 | 7.361 | - | - | - | - | 190 | 225 | 2.97 | - | 2757 | - |
| | Pressed | { 1.640 1.42 | 6.95 4.93 | 7.361 - | - - | - - | - - | - - | 190 - | 225 86 | 2.97 - | - - | 2757 4100 | - - |
| Tritonal (TNT 80 & Al 20%) | Solid | { 1.42 1.79 | 4.93 7.02 | - - | - - | - - | - - | - - | - 127 | 86 - | - - | - - | 4100 5410 | - - |

Composition B, and of 77/23 Cyclotol were measured by Deal (Ref 1) by determining initial free-surface vel as a function of thickness for 24ST-Al plates in contact with the detonating expl. The pressures detd were as follows: RDX 338, TNT 189, 64/36 Comp B 292, and 77/23 Cyclotol 313 kilobars

Coleburn (Ref 2) also detd the CJ pressures of several pure & mixed expls

Dremin & Shvedov (Ref 3) measured by an electromagnet method the CJ pressure & time of reaction in detonation waves of RDX, TNT, PETN, Tetryl, DINA, and of some of their mixts. The results obtd were significantly different from previous data. An attempt was made to explain this difference

Refs: 1) W.E. Deal, "Measurement of Chapman-Jouguet Pressure for Explosives", JChemPhys **27**, 796-800 (1957) 2) N.L. Coleburn, "Chapman-Jouguet Pressures of Several Pure and Mixed Explosives", NOLTR **64-58** (1964) 3) A.N. Dremin & K.K. Shvedov, ZhPriklMekhan i TekhnFiz **1964**(2), 154-59 & CA **61**, 14456 (1964)

Detonation, Chapman-Jouguet Pressure Measurements. See under Detonation (and Explosion), Experimental Procedures and also paper by W.E. Deal, JChemPhys **27**, 796-800 (1957)

Detonation, Chapman-Jouguet Process. It is either Chapman-Jouguet Deflagration or Chapman-Jouguet Detonation (qv)

Detonation, Chapman-Jouguet Stability Condition. See under Detonation, Chapman-Jouguet Condition

Detonation, Chapman-Jouguet State. State in which reaction products are under the CJ Condition

Detonation, Chapman-Jouguet Surface. See under Detonation, Chapman-Jouguet Point

Detonation, Chapman-Jouguet Temperature. It is one of the CJ Parameters and their values are listed in the Table under Detonation, Chapman-Jouguet Parameters

Detonation, Chapman-Jouguet Theory.

Detonation waves are shock waves which are sustained by the energy of the chemical reaction that is initiated by shock compression. They develop generally from flame-generated pressure pulses into shock waves, and propagate spherically in suitably strong mixts when initiated by a small charge of HE. Their rate of propagation is limited by the rate at which a shock wave can travel. Thus, it has been possible to develop a theory of propagation on the basis of hydrodynamics alone and to compute deton velocities from the physical & chemical props of the expl medium. The current theory of shock & deton waves is largely founded on the work of Chapman-Jouguet & R. Becker

The treatment of sustained deton, often called the Chapman-Jouguet theory, is based on four assumptions:

- 1) the deton approaches a steady state
- 2) the flow is laminar & one-dimensional
- 3) the deton products approach a state of chem equilibrium some distance behind the deton front, and
- 4) the deton vel is calculated using equations for the conservation of mass, momentum, and energy; an equation of state for the deton products; and the following postulate

Chapman & Jouguet postulated that the detonation velocity D is given by:

$$D = u + c$$

where u = the material velocity at the end of the reaction zone and
 c = local velocity of sound

Thus, the deton vel relative to the reaction products, $D-u$, is equal to the local vel of sound in the reaction products. No complete theoretical proof has been given the CJ Theory, but it does agree with experimental observations

Dunkle (Ref 7) reports that the CJ Theory deals with adiabatic transformations in steady non-viscous, one-dimensional flows in stress tubes or ducts of constant cross-section. This theory interprets deton waves as shock waves in which a continuing degradation of mechanical (shock) energy into heat is balanced by

the release of energy thru chemical reactions induced in the shocked substance

Wood & Fickett (Ref 5) proposed experiments to test the validity of the CJ theory, not requiring knowledge or assumptions about the nature of the equation of state of the detonation products, by making variations of the initial state of the expl. Davis et al (Ref 6) reported the results of some experiments, by the method of Fickett & Wood, in which 1) the initial state of the expl was varied by using mixts of Nitromethane & another liq (made of equal parts of HNO_3 , acetonitrile & water) which has the same atomic compn as NM and 2) the initial state was varied by using TNT as liq and as solid. Their results showed that the CJ theory was violated. The calcd pressures were 15-20% below the measured pressures. Results of measurements using other expls were also presented to support their conclusion that the theory fails. No explanation or alternative theory was offered by Davis et al

Refs: 1) NDRC Summary Rept of Div 8, Vol 1 (1946), p 84 2) W.G. Penney et al, ProcRoySoc **204A**, 1-33 (1950) 3) Cook (1958), pp 66ff 4) B. Lewis & G. von Elbe, "Combustion, Flames and Explosions of Gases", Academic Press, NY (1961), pp 511ff 5) W.W. Wood & W. Fickett, Physics of Fluids **6**, 648 (1963) 6) W.C. Davis et al, 4thONRSympDeton (1965), 84-85 (Abstract) & Physics of Fluids **8**, 2169-82 (1965) 7) C.G. Dunkle, private communication (1969)

Detonation, Chapman-Jouguet Variables. Same as Detonation, Chapman-Jouguet Parameters

Detonation, Chapman-Jouguet Velocity of. It is one of the CJ Parameters, some value of which are listed in the Table under Detonation, Chapman-Jouguet Parameters

Detonation, Chapman-Jouguet Wave and Flow Behind It. Accdg to Evans & Ablow (Ref 6), the C-J hypothesis is supported by the agreement betw calcd and observed deton properties under exptl conditions which make the one-dimensional approxi-

mation a good one. Its theoretical justification is usually based on arguments which depend upon abandoning the simplification of instantaneous reaction. Becker (Ref 1) equated entropy with the probability of occurrence of a flow. Since the entropy increases with pressure along a Hugoniot curve [See Fig 3 under DETONATION (AND EXPLOSION), THEORIES OF, Note 11], the entropy of final states in a strong detonation is greater than the entropy of states in a weak detonation. Thus, accdg to Becker, strong detonations are more probable than weak detonations. As strong detonations are possible only for $u_p > (u_2)_x$, the most probable flow for $u_p \leq (u_2)_x$ is the *Chapman-Jouguet Flow*. Here u_p = velocity of piston which compresses the gas and $(u_2)_x$ is that particular value of the gas velocity behind the gas front which satisfies the C-J condition (Ref 6, p 142)

In a somewhat similar thermodynamic argument, Scoriah (Ref 2) stated that the work content for the C-J detonation state corresponds to a maximum degradation of energy. Zel'dovich (Ref 4) demonstrated the unsatisfactory nature of the thermodynamic arguments by remarking that the increase in entropy across a shock is not sufficient to guarantee that a shock will form. A piston which compresses the gas is also necessary (Ref 6, p 142)

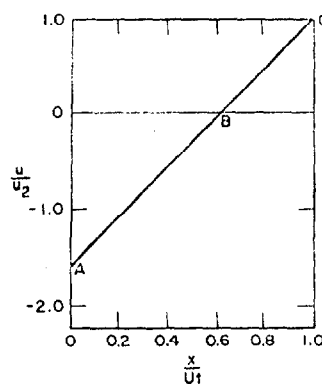

FIG 1 Flow behind a Chapman-Jouguet detonation for $u_c/U = 1/3$, $\gamma = 1.3$ (Taylor)

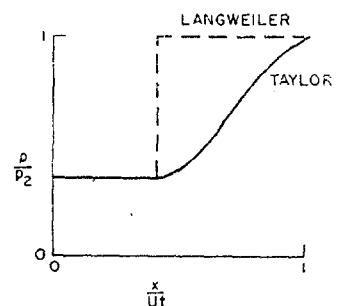

FIG 2 Pressure in rarefaction wave behind Chapman-Jouguet point according to Taylor and to Langweiler

Taylor (Ref 5) obtd a transient flow behind a C-J discontinuity using Riemann equations for polytropic gases. A plot of u/u_2 vs x/Ut shown in Fig 12 of Ref 6 (See here Fig 1) is for $u_2 = U/3$, $c_2 = 2U/3$ and $\gamma = 1.3$, where u is material velocity in x direction, u_2 is material velocity immediately behind the discontinuity at Ut (U = velocity of C-J wave & t = time coordinate); c_2 = sound velocity and $\gamma = c_p/c_v$ (c_p = specific heat at constant pressure and c_v = sp heat at constant volume). Taylor calculated pressure in the rarefaction wave behind C-J point and plotted it in Fig given as Fig 12 of Ref 6 (Our Fig 2)

Langweiler (Ref 3) calculated the flow field behind a C-J detonation by assuming that the products maintain the velocity u_2 , pressure p_2 , and density ρ_2 until the passage of a rarefaction shock which reduces the velocity to zero. The rarefaction shock is assigned a velocity of $(U + u_2)/2$. The column of forward-moving gas, which Langweiler calls a **detonation head**, thus has a length which increases with time and is equal to $[U - (U + u_2)/2]t = (U - u_2)t/2$.

A schematic diagram of the pressure profile accdg to the model is shown as a dotted line in Fig 2 (Ref 6, pp 143-44)

Refs: 1) R. Becker, ZPhysik **8**, 321 (1922) & ZElektrochem **42**, 457 (1936) 2) R.L. Scoriah, JChemPhys **3**, 425 (1935) 3) H. Langweiler, ZTechnPhysik **19**, 271 (1938) 4) Ya. B. Zel'dovich, ZhurEksper i Teoret-Fiz **10**, 542 (1940); translated in NACA Tech Memorandum **1261** (1950) 5) G.I. Taylor, PrRoySoc **200A**, 235-47 (1950) 6) M.W. Evans & C.M. Ablow, ChemRevs **61**, 142-44 (1961)

Detonation, Chapman-Jouguet Zone of. See shock zone in Fig 1 under Detonation, Chapman-Jouguet Condition

Detonation (and Explosion), Characteristics. See Characteristics of Explosives and Propellants and also Detonation (and Explosion), Parameters and Characteristics

Detonation, Classical Theory of Plane Detonation Wave. The mechanism by which a detonation wave maintains itself and progresses thru an expl was investigated by Neumann (Ref 1). Support was found for the hypothesis that the deton wave initiates deton in the neighboring layer of the intact expl by the discontinuity of material velocity which it produces. This acts like a very vehement mechanical blow -- a mass-velocity of approx 1500 m/sec -- and is probably more effective at high temp

The velocity of the deton wave was detd by investigating all phases of the reaction. The results showed when the Chapman-Jouguet hypothesis was applicable and what formulas were to be used when it did not hold

The work of von Neumann was limited to plane waves in absolutely confined explns and to determinations that had reached a stationary state

Refs: 1) J. von Neumann, "Theory of Detonation Waves", OSRD Rept **549** (1942)

2) J.G. Kirkwood & W.W. Wood, JChemPhys **22**, 1915-16 (1954) & CA **49**, 2073 (1955)

(Structure of a steady-state plane detonation wave with finite reaction zone) (It is an analytical elaboration of von Neumann's model of detonation wave)

Detonation (and Explosion) of Combustible Dust-Air and Vapor-Air Mixtures. See Detonation (and Explosion) of Dusts and Mists (Vapors)

Detonation and Combustion, Mechanics of Propagation is discussed by G.N. Abramovich & L.A. Vulis in DoklAkadN **55**, 107-110 (1947) & CA **41**, 6723 (1947)

Some relations characteristic of the unidimensional steady propagation of deton and normal burning are given with special ref to the physical proof of the Chapman rule of the minimum vel in the deton wave

Detonation (and Explosion) of Composite Explosives. Composite expls used for most mining operations consist of intimate mixtures of detonating compds (such as NG), oxidizing salts (such as AN) and combustibles (such as

sawdust). The detonation of such expls may proceed, accdg to J. Taylor (Ref 1) as follows:

NG detonates first and very rapidly; this will break-up the sawdust and start the erosion of the AN grains. It is possible that the nitrate decomposes exothermally to yield oxidizing gases which diffuse to the surface of the combustible where exothermic oxidation may take place. On the other hand, the sawdust may decomp to oxidizable gases and these may diffuse to the AN before being oxidized. The 3rd possibility is that the two components decomp separately and the final oxidation is completed in the gas phase.

Whatever the mechanism of the reaction between AN and combustibles, it may be, in some cases, very rapid, as for example for intimate mixts of finely ground AN & starch (or cork). Such mixts deton rapidly without the aid of a sensitizing agent like NG, and their velocities of deton are quite high. The same is true of finely divided mixts of AN & Al. (See also Refs 2 & 3)

Refs: 1) Taylor(1952), 183-84 2) W.E. Gordon, "Detonation Limits in Composite Explosives", 10thSympCombstn(1964), pp 833-38 3) I.C. Skidmore & S. Hart, "The Equation of State of Detonation Products Behind Overdriven Detonation Waves in Composition B", 4thONRSympDeton(1965), pp 47-51

Detonation (and Explosion) of Composite Propellants- Theoretical Treatment. Boyer & Grandey (Ref 2) describe a mathematical model for the detonation process, along the lines set forth by Hubbard & Johnson (Ref 1). This model is represented by a set of basic equations consisting of the hydrodynamic equations, the chemical rate equations and the equations of state. The rate equations are based upon three different processes: an ignition reaction, one or more grain burning reactions and a diffusion controlled reaction having, respectively, the Arrhenius form, the Eyring grain burning form, and a form derived from diffusion theory. Solution of the set of basic equations is accomplished by numerical integration making use of an electronic computer (IBM 709). The results of some calculations are presented which show

the dependence of detonation behavior upon propellant parameters. Correlation with experimentally observed detonation behavior is discussed

Refs: 1) H.W. Hubbard & M.H. Johnson, *JApplPhys* **30**, 765-69 (1959) 2) M.H. Boyer & R. Grandey, pp 75-98 in "Detonation and Two-Phase Flow", by S.S. Penner & F.A. Williams, Academic Press, NY (1962) (13 refs)

Detonation, Computers in. See under COMPUTER AND COMPUTER PROGRAMS

Detonation (and Explosion) of Condensed (Liquid and Solid) Explosives.

Detonation and explosion in condensed phase (solid or liquid as opposed to gas, dust or vapor) explosives were briefly discussed in Vol 3 of our Encycl, p C495-R, under "Condensed Explosives", but the following comments of C.G. Dunkle (Ref 22) may be added. His discussion is based mainly on the information obtained at the 10thSympCombstn(1964) and other Symposiums

Detonation in gases has been more thoroughly investigated than in condensed phases, and continues to receive the major share of attention. In a broad sense the chain of events is the same in both cases (Ref 7, p 2), but in gases is spread out in both space and time, being therefore more easily observed

It should be noted that solid explosives may be detonated in any condition from a coarse powder to a single crystal (Ref 6, p 166). Heterogeneous polycrystalline mixtures can be termed "solid" only by convention; phenomena such as grain erosion in the detonation reaction zone are of dominant importance. They depend in a complex way on the intercrystalline free space and on a free space more strictly defined, the difference between the volume of the crystals and the volume of the ions therein

Nevertheless the conditions within the detonation front must profoundly modify the physical structure. Whether or not it can any longer be considered a solid phase, hydrodynamic theory has been applied to the study of detonation in initially solid explosives

with considerable success, in view of the differences in conditions. Detonation in a condensed-phase explosive differs from detonation in a gas in important respects, for instance, the higher temperatures and much higher pressures developed, the higher complexity of the explosion products, and the greater importance and strength of the lateral motion and pressure gradients

It is generally considered that when a sufficiently strong shock wave is generated in an explosive liquid or solid, the wave rapidly develops into a self-sustaining detonation wave. In detonations the pressure rises to its peak value in an extremely short time, on the order of a nanosecond, even in gaseous mixtures, and then decays quite rapidly with an exponential decay constant of the order of a microsecond. This makes detonation pressures difficult to measure, and even leads to some question about the meaning of the term itself. There is evidence, not too firm, that a very high "spike pressure" exists for an extremely short time, and that the exponential decay takes place from a lower, the Chapman-Jouguet (C-J) pressure. In any event the C-J pressure is much more accessible to measurement, and is usually referred to as the *detonation pressure*

It has been suggested that the spike pressure is due not to molecular impacts in the usual sense but rather to interatomic repulsion forces (Ref 6, p 298 & Ref 13, p 25a). The distance between chemically bound atoms in many molecules is shorter than the sum of the radii of the same atoms when free, and the specific volume of the compound may be actually smaller than the total covolume of its gaseous products. If, as seems plausible, the drastic compression within the detonation front ruptures chemical bonds, many atoms suddenly expand, exerting forces like those by which solids resist compression. Such forces could result in a spike pressure much higher than the peak pressure of the non-reactive shock front, exert a brisant effect on the surroundings, and expedite the progress of the detonation wave. This view accords with observations of cases in which

an expansion seems to be a necessary preliminary to the detonation reaction (eg Gey & Kinaga in Ref 11a) [L.R. Carl in "The Breaking Theory of Detonation", (qv) refers to this effect]. The endothermic breakdown of the molecules reduces the temperature rise caused by the adiabatic compression within the detonation front

The duration of the spike pressure may be considered an "induction time" preliminary to the chemical reaction, which occurs as the atoms expand to their normal volume, and generates gas pressure in the usual sense. Most of the heat is evolved in this stage, which is longer in both time and space; the pressure here is due primarily to molecular impacts and is lower than in the spike, but still high because of the heat evolution and the consequent temperature rise. The C-J temperature is higher than the adiabatic constant-volume explosion temperature, because the heating in the reaction zone results not only from the evolution of chemical energy but also from the compression energy or "Hugoniot term"

Unfortunately, the extensive work on gas detonations has had little impact on the development of the theory for condensed phases. The reason is the lack of a reliable equation of state for these. While fundamental significance must be achieved eventually, an empirical fit to actual performance would be helpful at present. A sophisticated general equation for the isentrope, which is a C-J isentrope, is called for. Above 150-200 kbar, the polytropic (gamma-law) equation of state is valid (Skidmore & Hart, in Ref 19, p 47). At the lower pressures, the test data do not fit the gamma-law curve (Kury et al, Ref 19, p 7), and terms have been added in an attempt to adjust to this situation. The "two-term Wilkins" (Wilkins et al in Ref 18, p 776) is a fair approximation (See also Ref 13, p 18a)

In order to obtain even reasonable agreement with experiment, as Zel'dovich and Kompaneets pointed out (Ref 12a, p 293), it is necessary to treat the covolume as a variable quantity depending on the volume. This means that the molecules cannot be con-

sidered to be "solid particles" as in the kinetic theory of gases

Cook also found the covolume to be function of specific volume only, and this was also discussed in Ref 6, p 183. In this connection (Ref 13, p 15d), it may seem to make no difference whether covolume depends on specific volume or [as in the MacLeod Equation of State, described and Detonation (and Explosion), Equation of State] on pressure. Nevertheless, dependence on specific volume implies that the internal energy depends on pressure only, whereas pressure dependence would mean that pressure contributes to internal energy in the form of intermolecular potential energy. With the first alternative, the detonation temperature rises monotonically with rising loading density; with the second it decreases. Despite this difference the equations give the same values of detonation pressures and gas densities, and thus the same total energies (See also Refs 1, 3, 5, 5a, 5b, 8, 9, 10, 11, 12, 14, 15, 15a, 16b, 17a, 17b, 18, 18a, 19a-g, 20, 21, 22 & 23a-d and Addnl Refs A to Z, inclusive)

Refs: 1) J. Taylor, *PrRoySoc* **204A**, 30-1 (1950) (High- and low-regimes in condensed expls) 2) Taylor (1952), 87-110 (Deton in condensed expls yielding only gaseous products); 111-38 (Deton in expls whose products contain a condensed phase) 3) E. Sanger *CR* **235**, 461-63 (1952) (Deton of liquid and solid expls) 4) E. Haeuseler, *Explosivst* **1953**, 64-8 (Deton of liquid expls) 5) M. Murgai, *ProcNatInstSciIndia* **20**, 548-56 (1954) (An equation of state for condensed expls) 5a) H.D. Mallory & S.J. Jacobs, "The Detonation Zone in Condensed Explosives", p 240 in the *2ndONRSympDeton* (1955) 5b) A.W. Campbell et al, "Detonation in Homogeneous Explosives", *Ibid*, pp 336-59 5c) R.D. Cowan & W. Fickett, "Calculation of the Detonation Properties of Solid Explosives with the Kistiakowsky-Wilson Equation of State", *JChemPhys* **24**, 932-39 (1956) 6) Dunkle's Syllabus (1957-1958), 166, 183, 191-202 & 298 7) Cook (1958), p 62 (HKWB equation of state in condensed expls); 77-9,

123-28, 138, 148 & 191 (Condensed expls, reaction zone) 8) Baum, Stanyukovich & Shekhter (1959), 664-753 (Explan in condensed media) 9) A. Vidart *MP* **42**, 83-144 (1960) (Calc of characteristics of condensed expls) 10) Andreev & Belyaev (1960), 193-210 (Deton of condensed expls) 11) L.G. Bolkhovitinov, *DoklAkadN* **130**, 1044-46 (1960) (Low-speed deton of liquid expls) 11a) *3rdONRSymp-Deton* (1960), pp 469-98, A.W. Campbell et al, "The Shock Initiation of Detonation in Liquid Explosives" 12) R.F. Chaiken, *JChemPhys* **33**, 760 (1960) & in *3rdONRSymp-Deton* (1960), pp 304-08 (Comments on hypervelocity wave in condensed expls) 12a) Zel'dovich & Kompaneets (1960), Chapter 4 (Detonation in condensed expls) 13) Dunkle's Syllabus (1960-1961), pp 15d, 17a-17f, 18a-18f, 19a-19e & 25a-25d 14) A.Ya. Apin et al, *ZhPriklMekh i TekhnFiz* **1961**, No 5, 117-18 & *CA* **56**, 11871-72 (1962) (Calc of exponents of a polytropic curve of expln products of condensed expls) 15) A.W. Campbell et al, *PhysFluids* **4**, 498-510 (1961) (Shock initiation of deton in liquid expls) 15a) *Ibid*, pp 511-22 (1961) (Shock initiation in solid expls) 16) R.O. Miller, "Estimating Caloric State Behavior in Condensed-Phase Detonations", pp 65-74 in S.S. Penner & F.A. Williams, "Detonation and Two-Phase Flow", Academic Press, NY (1962) 16a) R.F. Chaiken, "A Kinetic Approach to Detonation of Homogeneous High Explosives", *8thSympCombstn* (1962), pp 759-67 & *CA* **57**, 10092 (1962) 16b) R.W. vanDolah et al, "Low Velocity Detonations in Liquid Explosives", International Conference on Sensitivity and Hazards of Explosives", London, Oct 1963 17) A.N. Dremin et al, *ZhPriklMekhan i TekhFiz* **1963**, No 1, pp 130-32 (Detonation mechanism in liquid explosives) 17a) C.L. Mader, "Detonation Properties of Condensed Explosives Computed Using Becker-Kistiakowsky-Wilson Equation of State", Los Alamos Scientific Laboratory Report **LA-2900** (1963), Contract W-7405-ENG 36 with AEC (Atomic Energy Commission) 18) W.E. Gordon, "Detonation Limits in Composite Explosives",

- 10thSympDeton(1964), pp 833-38 18a) L.N. Stesik & N.S. Shvedova, ZhPriklMekhan i TekhFiz **1964**, No 4, pp 124-26 & CA **61**, 15922(1964) (Detonation of condensed explosives having low charge densities) 19a) J.W. Kury et al, "Metal Acceleration by Chemical Explosives", 4thONRSympDeton(1965), pp 3-13 19b) I.C. Skidmore & S. Hart, "The Equation of State of Detonation Products Behind Overdriven Detonation Waves in Composition B", Ibid, pp 47-51 19c) W.C. Davis et al, "Failure of the Chapman-Jouguet Theory for Liquid and Solid Explosives", Ibid, pp 84-5 19d) R.W. Watson et al, "Detonation in Liquid Explosives - The Low-Velocity Regime", Ibid, pp 117-25 19e) S.D. Gardner & J. Wackerle, "Interactions of Detonation Waves in Condensed Explosives", Ibid, pp 154-55 19f) W.E. Gordon, "Detonation Limits in Condensed Explosives", Ibid, pp 179-97 19g) R.E. Duff, "Summary of Papers on Condensed Phase Detonation" (Invited Review), Ibid, pp 198-201 20) PATR **2700**, Vol 3(1966), p C495-R to C496-L, "Condensed Explosives" 21) 11thSympCombstn(1967): Donna Price, "Contrasting Patterns in the Behavior of High Explosives", pp 693-702 22) C.G. Dunkle; private communication, December 1967 23a) A.N. Dremin, "Critical Phenomena in the Detonation of Liquid Explosives", 12thSympCombstn, Poitiers, France, July 14-20, 1968; Published in 1969, pp 691-99 23b) C. Fauquignon & R. Cheret, "Generation of Detonation in Solid Explosives", Ibid, pp 745-51 23c) D. Price & A.R. Clairmont, Jr, "Explosive Behavior of Nitroguanidine", Ibid, pp 761-70 23d) L.G. Bolkhovitinov et al, "Initiation of Detonation in Low-Density Trotyl by Air Shock", Ibid, pp 771-77
- Addnl Refs:* A) A.F. Belyaev, DoklAkadN **18**, 267 (1938) (The origination of detonation in expls under the action of thermal impulse) B) A. Ya. Apin, DoklAkadN **24**, 922(1939) (On the mechanism of explosive dissociation of Tetryl) C) V. Rosing & Yu.B. Khariton, DoklAkadN **26**, 360(1939) (The deton cutoff of expl substances when the chge diameters are small) D) I.D. Landau & K.P. Stan-yukovich, DoklAkadN **46**, 362-64 & 396-98 (1945); CA **40**, 4523-24(1946) (On the study of detonation in condensed expls) E) A.Ya. Apin & V.K. Bobolev, DoklAkadN **58**, 241 (1947) (On the nature of detonation conversion in powdered expls) F) H. Jones & A.R. Miller, PrRoySoc **194A**, 480-507(1948) (Detonation of solid expls) G) T.C. Tranter, Nature **162**, 335(1948) & **174**, 81 (1954) (Low-order detonation in solid expls. Influence of surface chilling on the deton behavior of cast TNT) H) H. Jones, Pr-RoySoc **204A**, 9-12(1950) (Theoretical considerations of the deton of solid expls) I) O.A. Gurton, PrRoySoc **204A**, 31-2(1950) (Fading of deton in solid expls) J) A. LeRoux, MP **33**, 283-321(1951) (Deton of solid expls by impact with solid shots at high velocities) K) M.A. Cook et al, "Reaction Kinetics and Thermo-Hydrodynamics of 80/20 Tritonal", Univ of Utah, Tech Rept **XXIX**(1954), Contract N7-onr-45107 (Conf) (Not used by us) L) M.A. Cook, JPhysChem **58**, 1114(1954) (A study of the equation of state for EDNA) M) H. Sudo, JIndExplsSocJapan **15**, 277-81(1954) (Photographic study of deton of solid expls) N) G. Schweikert, Explosivst **1955**, 197-200 & **1956**, 10-14 (Deton theory for solid expls) O) M.A. Cook et al, JChemPhys **24**, 60-7 (1956) (Velocity-diameter and wave shape measurements and the determination of reaction rates of TNT) P) M.A. Cook & R.T. Keyes, JChemPhys **24**, 191-201(1956) (Rate of reaction of TNT in deton by direct pressure measurement) Q) R.D. Cowan & W. Fickett, JChemPhys **24**, 432-39(1956) (Calc'n of deton props of solid expls) R) F.P. Bowden et al, Nature **180**, 73-5(1957) (Initiation and growth of expln in solids) S) S.J. Jacobs, ARSJ **30**, 151-58(1960) (Discussion on recent work on detonation in condensed explosives) T) M.H. Boyer & R.A. Grandey, "Study of Detonation Behavior of Solid Propellants", Ford Motor Co, 15th Quarterly Rept(1961), Contract NOrd 17945, Task 1, Aeronautics Div Publication No **U-1323** U) W.C. Maurer, "Detona-

tion of Ammonium Nitrate in Small Drill Holes, "Colorado School of Mines, Golden, Colorado (1963), 105pp; CA 59, 15116(1963) V) C.L. Mader, "A Study of One-Dimensional Time-Dependent Reaction Zone of Nitromethane and Liquid TNT", Los Alamos Scientific Lab Rept LA-3297 (1965) W) A.K. Parfenov & A.Ya. Apin, "Low Velocity Detonation in Pulverized Explosives", Scientific and Technical Problems of Combustion No 1, 109-11 (1965). Thru USDeptCommerce JRRS 32529, pp 151-55, TT65-33008 X) C.L. Mader, "The Time-Dependent Reaction Zone of Ideal Gases, Nitromethane and Liquid TNT", LASL Rept LA-3764 (1967) Y) D. Price, "Contrasting Patterns in the Behavior of High Explosives", 11thSympCombstn(1967), pp 693-702 Z₁) S.R. Brinkley, "Temperature Explicit Equation of State of the Products of Condensed Explosives", 12thSympCombstn(1968) Abstracts, p 90 (Not found in 1959 publication of papers) Z₂) C.L. Mader, "One- and Two-Dimensional Flow Calculations of the Reaction Zones of Ideal Gas, Nitromethane, and Liquid TNT Detonations", Ibid, pp 701-10

Detonation (and Explosion) in Condensed Media (or Phase). See Detonation (and Explosion) of Condensed (Liquid and Solid) Explosives and also Detonation (and Explosion) of Composite Explosives

Detonation, Conformal Solution (CS) Theories. See under Detonation, Longuet-Higgins (LH) Theory

Detonation, Continuity Tests for Picatinny Arsenal Flexible Explosives. The tests are devised and described by J.L. Uraco in NavWepLab TM No 17/65 (1965)

Detonation, Contrasting Patterns in the Behavior of High Explosives in. See Contrasting Patterns in the Behavior of High Explosives

Detonation, Convergence Effect in. See under Detonation (and Explosion), Luminescence (Luminescence), Produced on

Detonation, Cook's Geometrical Model Theory of. See Detonation, Geometrical Model Theory of Cook

Detonation (and Explosion), Craters in. This subject was briefly discussed in Vol 3 of Encycl, pp C553-L to C553-R, under the title: "Crater, Cratering and Cratering Effect". A more detailed description was given on pp 40-44 in the book of C.S. Robinson, "Explosions, Their Anatomy and Destructiveness", McGraw-Hill, NY(1944)

Detonation-Critical and Limiting Charge Densities, Charge Diameters and Detonation Velocity Relationships. See under DETONATION VELOCITY-CHARGE DIAMETER-DENSITY RELATIONSHIPS

Detonation, Critical Phenomena in. A.N. Dremin discussed in the 12thSympCombstn (1968), pp 691-99 critical phenomena in liquid explosives

Detonation in Crystals. Phenomena associated with detonation in large single crystals of explosives was discussed by T.E. Holland et al, in JApplPhys 28, 1212(1957)

Detonation, Curved Front Theory of Eyring et al

This is one of the three approximate theories of "nonideal" detonations (See under Detonations, Ideal and Nonideal), the other two being the "Nozzle Theory" of Jones (also known as "Expanding-Jet Theory") (described here under Detonation, Nozzle Theory of Jones) (Ref 5, p 123) and the "Geometrical Model Theory of Cook" (described under Detonation, Geometrical Theory of Cook) (Ref 15, pp 125-26). There is also "Qualitative Theory" described by Taylor (Ref 3, pp 145-48)

A qualitative description of Eyring et al's approach to the "curved-front theory" is given by Taylor (Ref 3, pp 150-52) in order to avoid the algebraic complexity of the theory. It has been argued that the effect of lateral pressure-losses should cause the wave front to become curved into a lens-shaped figure convex at the front and not remain plane as

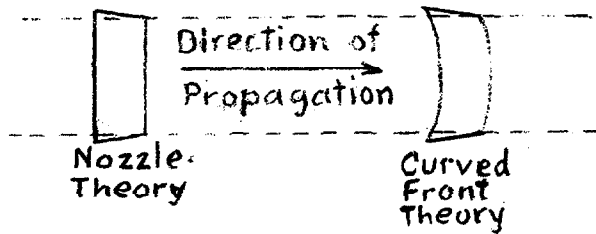

Fig 1 Comparison of Curved Front Theory with Nozzle Theory

Jones assumed. It has, in fact, been shown experimentally by Herzberg et al (Ref 2, p 119) that the detonation wave fronts are curved and that the curvature increases as the charge diameter is reduced. A simple method by which this curvature can be illustrated is provided by the use of a high-speed "Streak Camera" (same as "Smear Camera" described in Vol 2 of Encycl, p C16-L).

If a plane-ended cylindrical cartridge fired from one end is directed towards the slit of the camera so that the other plane end is in focus, the image produced on a film moving at right angles to the slit will record the appearance of light at various places in chronological order. When the deton wave reaches the end of the cartridge and meets air, intense illumination is produced, and in all cases this illumination appears at the center of the cartridge first, and produces a trace which is curved towards the edges of the charge. This method gives exact shape of the front wave if the writing speed on the film is exactly equal to the product of wave velocity and optical magnification (Ref 3, p 151). Plate III, given in Ref 3, illustrates the curvature of the wave front in a cartridge of liquid NG (See Fig 2)

In Dunkle's Syllabus (Ref 4, p 210) it is stated that Eyring et al ascribed (in Ref 1) the curvature of the front to the rarefaction wave entering the reaction zone at the edge of the charge. Since the local velocity of sound is greater than the opposing component of the detonation velocity, such a rarefaction wave will overtake the front of the wave and slow down the edge of the detonation front, thereby causing it to curve into

an approximately spherical surface. This process will continue until the angle of intersection of the wave front with the edge of the charge is small enough so that the rarefaction wave is no longer reflected. The steady-state velocity will now be below that of a plane wave because of the curvature of the front

Eyring et al (Refs 1 & 3) first investigated the effect of curvature of the wave front on the detonation velocity. They obtained a relation between the ratio of the actual to the ideal wave velocities (D/D_0) on the one hand and the ratio of the reaction zone length to the radius of curvature of the front (X/r) on the other. The reaction zone was defined as the zone between the CJ (Chapman-Jouguet)-layer. If the wave front is assumed to maintain its

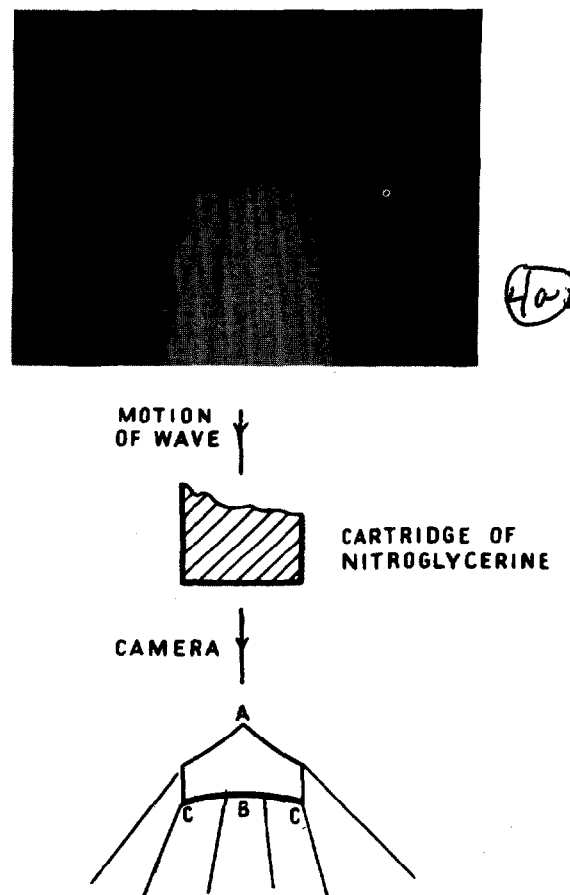

Fig 2 End-on photograph of the detonation of nitroglycerine showing the curved front.

roughly spherical shape as it advances, the radial velocity at any point will be

$$D_r = D_0 \cos \phi,$$

where ϕ is the angle betw the axis of the charge and the normal to the wave front

It is possible, thru step-by-step graphical construction, to draw the shape of the curved front for any value of (D/D_0) using the reaction zone (X) as the unit of radius. On the assumption that the curvature becomes tangential at the side of a bare charge, a relationship betw the charge radius (R) and (X) was obt'd. Plotting the ratio (X/R) against (D/D_0) gives an approx linear curve which is represented fairly well by:

$$D/D_0 = 1 - 0.5(X/R)$$

Reaction-zone lengths calcd from this theory are somewhat smaller than those calcd from the "Nozzle Theory of Jones"

Refs: 1) H. Eyring et al, ChemRevs **45**, 99 (1949) 2) G. Herzberg et al, Ibid, **45**, 119 (1949) 3) Taylor (1952), 145-52 4) Dunkle's Syllabus (1957-1958), 210-12 5) Cook (1958), 123-25

Detonation Cutoff of Explosive Substances. See under Detonation, Attenuation, Break, Cutoff, Decay, Dying and Extinction, Fading and Failure of and also under the next item

Detonation of Cylindrical Charges. Investigation of propagation of detonation in cylindrical charges of explosives conducted in Russia and described in the book of Zel'dovich & Kompaneets (Ref 3), is already briefly discussed in this Section, under "Detonation, Attenuation, Break, Cutoff, Decay, Dying out, Extinction, Fading, and Failure of". It was pointed out that detonation is propagated without stopping along the cylinder only in the case when the diameter of the cylinder is larger than some definite value, known as *critical-charge diameter*, whereas for a smaller diameter the detonation *dies out*. Rozing & Khariton (Ref 1) called this phenomenon *cutoff* and they found that the critical diam for NG in thin glass tubes is ca 2 mm. The influence of the chge diam on deton propagation is connected with the fact that a sub-

stance in the shape of a cylinder and under pressure expands not only forward and backward along the cylinder axis, but also laterally, along the radius. The greater the diameter, the lesser is the role played by *lateral expansion* (See "Detonation, Lateral Expansion in")

Fauquignon et al (Ref 6) who studied detonation of a cylindrical charge of cast *French "D" Explosive* (RDX 85 & TNT 15%) came to the conclusion that such detonation may be considered as a steady phenomenon if the ratio length/diameter is large enough. The method used was similar to the flash-radiographic method first described by Clark (Ref 2) and later by J. Viard. It consists in following the displacement of one or more very thin gold foils, initially cast in the explosive, which are carried along by the burned gases at the same velocity. No perturbation was caused in the flow of gases by the presence of foils. This technique is not precise enough for the reaction zone examination, but is particularly useful for the study of the rarefaction in reacted products until rather low pressures are reached (~10 kbars), allowing, in accordance with the chosen theoretical flow model, the determination of the gases isentropes. Fig 10, p 45 of Ref 6 gives isentropes curve for burned gases of "D" Explosive. P_{CJ} was determined as 259 kbars at $\rho_0 = 2.186$ g/cc. There are 11 refs given by Fauquignon of which only Refs 2, 4 & 5 are listed here
Refs: 1) V. Rozing & Yu.B. Khariton, Dokl-AkadN **26**, 360 (1939) (The deton cutoff of expls when cylinder diameters are smaller than certain values) 2) J.C. Clark, JAppl-Phys **20**, 363-75 (1949) (Flash radiography applied to ordnance problems) 3) Zel'dovich & Kompaneets (1960), 213-16 (Detonation of cylindrical chges) 4) C. Fauquignon, CR **251**, 38-40 (1960) (Balistique Intérieure. Évaluation de la pression du choc initiateur d'une détonation) 5) J. Berger et al, Annales de Physique **5**[13], 51 & 1144-76 (1960) (Determination of detonation characteristics of solid explosives) 6) C. Fauquignon et al, "Detonation of a Cylindrical Charge. Study of the Flow of Burned Gases", 4thONR-SympDeton (1965), pp 39-46

Detonation, Cylindrical and Spherical in Gases. See under Detonation (and Explosion) in Gases

Detonation (and Explosion), Damage Caused by. See Vol 3 of Encycl, p D3-L under "Damage Effects of Organic High Explosives"

Detonation (and Explosion), Danger of. See Detonation (and Explosions), Hazards (Danger) of

Detonation (and Explosion), Danger in Chemical Plants. Vlad Sima gives in TechChem (Prague) 12(2), 66-69(1962) & CA 61, 526(1964) examples of plant construction with description of inherent dangers of explosions

Detonation (and Explosion), Dark Waves in. See under Detonation (and Explosion), Luminescence, etc

Detonation, Dead Pressing in. See "Dead-Pressed Explosives" in Vol 3 of Encycl, p D20

Detonation (and Explosion), Decay in. See under Detonation (and Explosion), Attenuation, Break, Cutoff, Decay, Dying out, Extinction, Fading, and Failure in

Detonation; Delayed-, After-, or Post-Reactions in. See Delayed-, After-, or Post-Reactions in Detonation

Detonation of Dense Heterogeneous Explosives, Transitional Events Leading to is discussed by F. J. Petrone & Donna Price in Naval Ordnance Laboratory Technical Report, **NOLTR 63-197** (1963). They report that by use of exptl pressure-time curves for confined burning, a numerical solution for the transition from ignition to slow burning to deton for dense heterogeneous expls has been obtd. This soln substantiates the hypothesis that the pressure-time history behind the deflagration determines the characteristics of the transition ahead of the combustion front. The calculations indicate that the transition is brought about by a compression wave which reaches a certain critical intensity and satisfies a particular pressure-time relationship at the deflagration

product-unreacted expl interface; the particular relationship depends on the subsequent pressure-unloading at this interface and any other energy lowering mechanism which cannot be neglected

It is also demonstrated that the simultaneous numerical solution by a difference scheme of both the transport and hydrodynamic mechanisms is probably impossible, but that the separate considerations of these two regimes, which is possible, can be connected in a physically reasonable manner

Detonation; Density-Detonation Velocity and Diameter-Detonation Velocity Relationships. See under Detonation Velocity-Charge Density Relationship and Detonation Velocity-Charge Diameter Relationship

DETONATION (AND EXPLOSION) DEVELOPMENT (TRANSITION) FROM BURNING (COMBUSTION) OR DEFLAGRATION

Accdg to definition given by Dunkle (Refs 2 & 3), as well as by other scientists such as Belyaev (Ref 1), Khitrin (Ref 4), Cook (Refs 5 & 7), Baum et al (Ref 11), Andreyev & Belyayev (Ref 18), etc:

Thermal ignition of an explosive or propellant usually results in burning (combustion) if the size of charge is small and if it is not confined. For example, if a charge of BkPdr or of smokeless propellant is spread on a dry surface in a thin, narrow, layer (like a ribbon), it burns with a velocity ranging from a few mm/sec to a few cm/sec, but if the same material is made in the shape of a heap and its mass exceeds a certain value (known as "critical value"), the burning will reach the velocity of a deflagration (few meters/sec to below 1000 m/sec) or becomes so rapid that a shock wave front will be set-up, resulting in an explosion ("low order detonation"), or a detonation ("high-order detonation"), even without any confinement. The critical mass varies with the explosive or propellant. It is extremely small for primary expls (such as LA or MF), larger for secondary expls (such as TNT, Tetryl, PETN or RDX) and still larger for smokeless proplnts or BkPdr

A detonation usually takes place when

the temperature and pressure increase during burning (or deflagration) beyond certain limits. As the burning rate is sensitive to pressure, confinement causes faster burning and an increase in pressure. This, in turn causes faster evolution of heat, rapid increase in temperature, and further increase in pressure, etc. Then the cumulative action of pressure and temperature suddenly transforms the rapid burning (or deflagration) to detonation which propagates at rates of several thousand meters per second (Compare with Ref 34, pp D38-L to D40-L.)

If a charge of BkPdr or of a smokeless propellant is placed in a cylindrical container with strong walls but loosely closed at one end (such as a metallic cartridge closed at one end with a projectile) and ignited, it will deflagrate and rapidly develop a sufficient pressure to eject the projectile. If the same charge is initiated in a completely confined container (such as a projectile or a bomb), it will explode and burst the container into rather large fragments. If the charge of BkPdr or smokeless propellant will be replaced by an HE (such as TNT, Comp B, etc) a high-order detonation will take place, bursting the container into rather small fragments

Griffiths & Grocock (Ref 19) found during their investigation of burning-to-detonation of RDX, HMX, PETN or Tetryl that, when gently ignited, without confinement, the detonation took place only after their rates of burning exceeded 1 m/sec

A good description of transition to detonation from combustion in gases is given by Zel'dovich & Kompaneets (Ref 17, pp 191-95);

If a combustible gaseous mixture, such as methane-oxygen located in a long pipe is ignited at one end (by means of a flame, incandescent wire, or a weak electric spark), there will be no detonation and no instantaneous combustion. Instead a flame will form which will propagate from layer to layer of gas through the tube by thermal conduction and the pressure will be practically constant everywhere. As the flame continues to propagate, its velocity gradually increases until at some dis-

tance from the origin of burning a detonation wave arises. This distance diminishes with increase of original pressure of gases and increases as the initial temp of the mixture increases. The duration of the *predetonation* period depends not only on the state of the original mixt but also on the hydrodynamic conditions for which propagation of the flame takes place; it also depends on the diameter of the pipe, and the state of the walls (smooth or rough). The distance depends very strongly on the compn of the mixt, and its dilution with inert components. There exist certain critical values of the compn and of initial pressure, known in Rus literature as *explosion limits*, beyond which no expln or deton can take place. For example, for methane-oxygen mixt, the lower limit is 10% CH₄ and the upper limit 60%

A careful examination of photographs of transition of combustion to detonation in gases, showed that this phenomenon cannot be considered as a continuous increase in the propagation velocity of the reaction from the normal flame velocity to the deton vel. Upon ignition normal propagation actually does not exist. Its vel gradually increases, but without attaining the deton vel. The deton wave arises suddenly, and its origination is easy to locate on a photograph since the brightness of the deton wave is considerably greater than the flame intensity. At the instant of formation of the detonation wave, a second wave evolves out of the same point, where this wave is propagated through the expln products as a shock wave. This is known as the *retonation wave*. At the point of detonation origin, there is frequently observed a disintegration of the pipe or some other indication of a sharp increase in pressure, exceeding that in the deton wave which is propagated further along. It was observed that at the point of deton origin, the ignition and emission of the deton took place at the same distance ahead of the flame front before the flame had arrived at this point. Thus the transition is not a continuous process as is combustion. This shows that combustion and deton differ not only in magnitude of propagation but also in character. Transition from combustion to deton is facilitated by wall roughness inside the pipes

Wachtell & McKnight (Ref 15) stated that DDT in solid propellants is considered to be essentially a physical process in which the linear burning rate of the bed of the material increases to the rate of several thousand meters per second, although the individual particles are consumed at the rate of only several hundred inches per second. The validity of this mechanism for propellants in granular form has been shown by a number of workers. This can also be applied to composite and homogeneous propellants if the growth of a shock front can be shown which is accompanied by an increasing break-up of surface of the propellant. The apparent non-detonability (thru transition) of NC colloided propellants is due to their dense surface preventing deflagration from taking place in the interstices of the materials. For composite propellants the continuous and highly elastic nature of the binder probably prevents this type of reaction. However, it has been shown that many highly elastic materials will undergo brittle failure when stress at very high strain rates is applied.

Gibson et al (Ref 12) who conducted at the BurMines an investigation of propellant detonability and the initiation and growth from deflagration to detonation, expedited the work by the use of both optical and electronic instrumentation. Since a metastable condition exists during the initiation period, conventional photographic streak and framing techniques must be supplemented with electronic methods to provide continuous indication of compression and ionization wave motion. Since opaque materials and those requiring strong confinement are difficult to study by optical means and since in the transition from deflagration to detonation a continuous record is essential, the existing methods (such as *probe systems* and *intermittent photography*) proved to be inadequate.

A method for *continuous determination of ionization wave propagation* was developed (See Refs 9 & 11). Basically the system uses a linear resistance element that is imbedded in the charge and usually positioned on the axis where charge symmetry will provide interactions of the greatest magnitude. In its

original form the element consisted of a resistance wire tightly coiled on an insulated core wire. When a constant current is present in the element, a measure of potential difference betw the downstream end and the ionized region determines the position of the front at that instant; thus an oscillographic display of position vs time will provide the velocity of the wave. The propellant was shredded in a food chopper and packed incrementally into a thick-walled steel reaction vessel. When a 6-mm rubber barrier was used as an attenuator, initiation was essentially instantaneous, but with a 20-mm thick barrier no deton resulted.

Later in the research, a variation of the resistance element technique was developed to permit the continuous measurement of a compression wave position with respect to time. With this modification the compression wave movement, during the period prior to establishment of an exothermal reaction, could be studied. The pressure-actuated resistance probe consists of a thin-walled me-

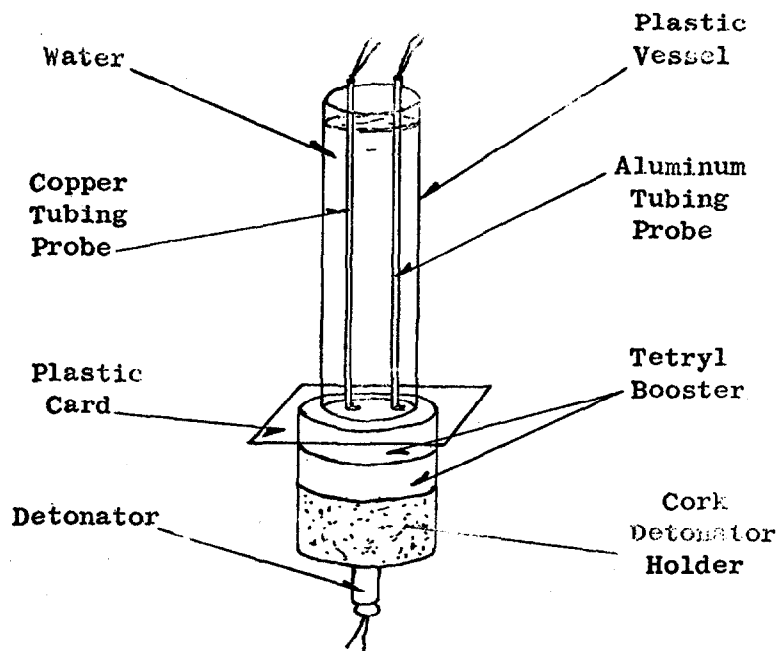

Fig 1 Comparison of Performance of Cu & Al Pressure-Type Resistance Element Probes

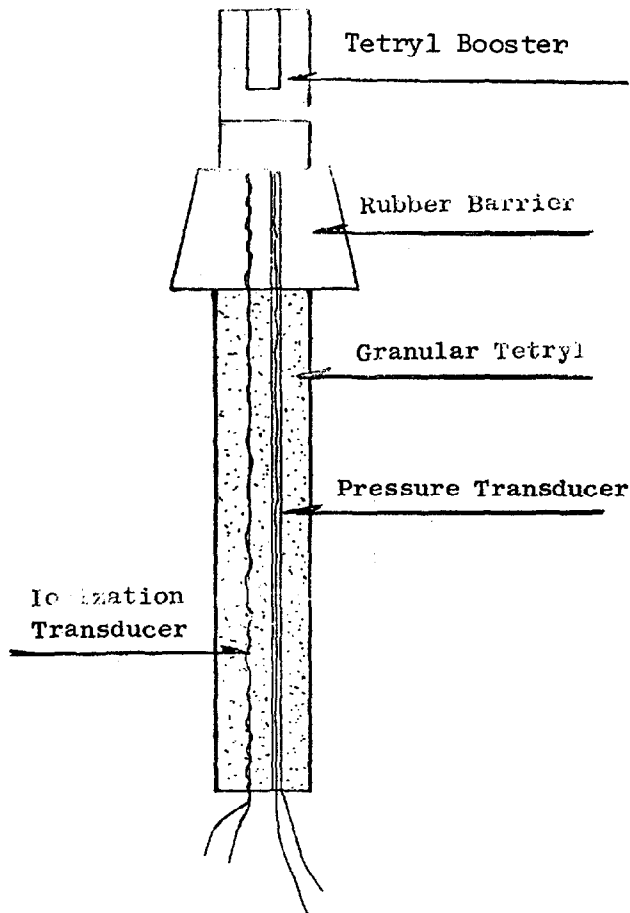

Fig 2 Charge Configuration Used to Compare Pressure Probe System with the Ionization Probe System. The Barrier Introduces a Detonation Delay Time

tal tube, ID 23 mm with 1.5 mm wall thickness, in which a coiled resistance element is placed. As the tubing wall collapses by external pressure, the element is shorted out - a process similar to that obtd by shorting of the bare resistance element in the presence of ionization - and the voltage is measured by oscillographic means. Al and Cu tubing were found suitable for pressure probes, such as shown in Fig 1, reproduced from Ref 12b. The Fig is reproduced here without oscillogram

The Al probe appeared to more accurately indicate compression wave propagation in that the trace discontinuity resulting from overdrive & decay to sonic velocity is better defined

A comparison of the ionization and pressure probe systems in a single test provides some insight into the initiation of a porous bed of granular expls by relatively weak shock waves. A typical exptl arrangement and the oscillograms produced are shown in Fig 5 of the report, which is reproduced here as Fig 2, without oscillograms

Here both types of probes are introduced into a column of Tetryl ($d = 1.0 \text{ g/cc}$) and the chge is initiated by a 14 g Tetryl donor with a 26 mm rubber barrier

Deflagration to detonation transitions for either the composite or HPDB (High-performance double-base) proplnts have not resulted from the use of mild thermal initiation even when strongly confined. It was generally observed that porous beds of material are required to provide compressioned heating that ultimately develops into a self-sustained deton, as was proposed by Andersen & Chaiken (Ref 23)

For investigation of deflagration to detonation transition of liq expls, the 50/50-NG/NGc mixture was chosen, mainly because it is a sensitive expl that exhibits two detonation orders and is transparent & amenable to photographic study. The mixt was placed in a transparent cylindrical container or square in cross-section and initiated by a high-density Tetryl booster with a rubber attenuator betw the donor and the material being studied. Background illumination from an electrically exploded wire was used to silhouette the event since its early stages are nonluminous; a ruled background light diffusion screen was placed betw the event and the light source. Fig 3 (Fig 18 of Ref 12b) reproduced here, shows a typical test vessel configuration used for initiation and growth studies in liq expls

A complete framing camera sequence of the initiation and growth of expln in NG/EGDN mixts is shown in Fig 19 of the report. Figs 20-28 give more detailed photographs of the same phenomenon (pp 7-13 of Ref 12b). They are not reproduced here

On pp 13-14 of the same rept is described investigation of solid systems, such as Tetryl, PETN, RDX & TNT with photographs shown

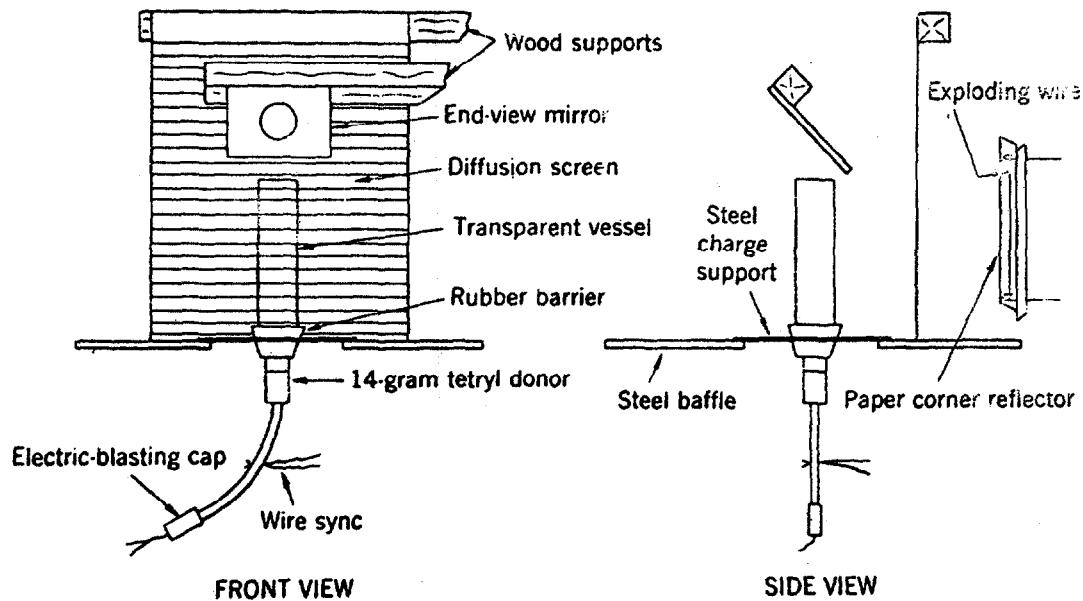

Fig 3 Typical Test Vessel Configuration Used for Initiation and Growth Studies of Liquid Explosives

in Figs 30-33, not reproduced here

In conclusion of this rept, Gibson et al state that deflagration to detonation transition seems to be related to the physical characteristics of an explosive or propellant bed

Gibson et al (Refs 12a & 12b) also conducted at the BurMines a research which was broader than transition from combustion and deflagration to detonation. The prime objective of the research was to evaluate mechanisms involved in the initiation and growth of detonation in systems that are capable of rapid exothermal decomposition. A second objective was to develop new instrumentation techniques and apply them to materials having known characteristics. Since interpretation of rapid phenomena prior to and accompanying deton require novel approaches and concepts for resolution, the existing techniques had to be either modified or replaced by other methods

On the whole, emphasis was given to HE's, but some attention was directed to evaluation of high-performance double-based propellants. The literature contains many hypotheses as

to mechanisms involved in the initiation process, but the authors suggested still another mechanism which involves a *cavitation phenomenon*

The following comments on the subject of transition from combustion or deflagration to detonation was communicated to us by Dunkle (Ref 35):

The velocity of advance of the front is supersonic in a detonation and subsonic in a deflagration. In view of the importance of a shock process in initiating detonation, it has seemed difficult to explain how the transition to it could occur from the smooth combustion wave in laminar burning. Actually the one-dimensional steady-state combustion or deflagration wave, while convenient for discussion, is not easily achieved in practice. The familiar model in which the flame-front advances at uniform subsonic velocity (v) into the unburnt mixture, has ρ_0 , P_0 , and T_0 for the density, pressure, and temperature ahead of the front, and ρ_b , P_b , and T_b behind:

$$\rho_b, P_b, T_b \xrightarrow{v} \rho_o, P_o, T_o$$

This looks simple, but in practice is quite unstable

Far from being difficult to explain, the appearance of a shock is hard to prevent in view of the chemically reactive nature of the medium in which the wave is advancing. Heat released in the combustion makes the gaseous products expand, and they push against the unburned mixture ahead of the wave front. Thus they set up a pressure wave of velocity (pr), called a "precompression" or "precursor" wave, which has been observed in schlieren photographs and streak camera records. The flame now advances into a mixture, still unburnt but "processed" by precompression and heating which increases the reactivity, in a third region between the other two:

$$\rho_b, P_b, T_b \xrightarrow{v} \rho_u, P_u, T_u \xrightarrow{pr} \rho_o, P_o, T_o$$

In place of subscripts b, u, and o, some authors use 3, 2, and 1, respectively. The velocities (v) and (pr) are both expressed relative to the walls and to the quiescent gas, which are stationary in "laboratory" coordinates. Here (u) indicates intermediate region

The flame therefore propagates into the processed mixture at a higher velocity than it moved initially into the original quiescent mixture, (v) is further raised by the movement of the compressed mixture itself in the same direction by virtue of its compression, and the velocity increments increase progressively. The rising flame velocity and growing strength of compression are shown by the curved lines often obtained in streak camera records. As the flame speeds up, it sends out another compression pulse behind which the values of ρ_u , P_u , and T_u become even higher. Their increases accelerate the flame again, and it generates a higher compression pulse. Just as when a series of increasingly strong pressure pulses advance in this way into an inert medium, the later ones overtake the earlier so as to "telescope" into a steep shock front

In this the discontinuities in pressure, temperature, and density are so abrupt that the chemical energy available is released

with extreme rapidity. The deflagration-to-detonation transition (DDT) is complete. A full-scale detonation is set up, with shock front and combustion front moving along together at the same high velocity

The precursor has initially a higher velocity than the flame front. An intermediate phase of the DDT, in which the shock front is still advancing faster than the flame front behind it, and each front can be considered separately, has been called a "pseudo-detonation", an "unsteady double discontinuity", or a "latent combustion phase"

There is general agreement that both fronts accelerate, and that the process is cumulative by virtue of their mutual interaction. This is promoted by turbulence, diffusion of hot particles ahead of the flame front, and passage of reflected shocks and rarefactions thru the "processed" medium (Ref 3, p 130). Advance of the flame front thru it differs more and more from the initial laminar burning

The shock is usually overtaken by the front of a process called a "flame", a "regular combustion phase", a "shock front", or a "low-order detonation". This process approaches the coalescence at a speed exceeding the stable detonation velocity and termed a "hyper-detonation velocity". Initiation behind a precursor wave, and a hypervelocity regime just before the final stable state, may characterize the DDT in both gaseous and condensed phases. In gases the shock wave may travel as much as several meters before ignition occurs, or if too weak may fail to induce detonation and may finally decelerate. A shock wave which would ordinarily be too weak to cause ignition may do so, after an induction period, if it encounters an obstacle which delays the gas flow. The "jump" toward coalescence in liquid explosives has been called "flash-cross". In solid explosives, the transition occurs in extremely short times and distances as in primary explosives, or only under very specific and difficultly reproducible conditions as in secondary explosives

The hypervelocity processes include two types (See Ref 22, p 11g):

In one, the precompressed medium simply becomes heated to the point where the ignition delay is so short that the flame appears virtually at the shock front. If there was any gap between them, when this temperature was reached, the flame jumps it at once. Such a jump might be made possible by a sudden increase in thermal conductivity accompanying a sudden upsurge of ionization as a certain temperature limit is exceeded. The energy released in such a fast-traveling process might be only that given by the combustion process rather than that corresponding to a shock wave moving at that speed. Objection has been raised that ionization potentials are too high for much of it to occur in a flame, or that equilibrium concentrations of ions to be expected under the conditions are too small. It seems well established, however, that free radicals and ions are present at well above equilibrium concentrations in flames. The excesses may be due to "chemi-ionization", breakdown of benzene or polymer molecules into fragments which ionize more easily, nucleation of free carbon

In the other type of supersonic process there is actually a supersonic detonation front of greatly enhanced destructiveness. The effect seems greatest if the front is not established until most of the explosive has been precompressed and processed. The processing under these conditions seems to include considerable chemical reaction and hence partial release of energy. This should then leave less energy to be released in the final chemical reaction. However, the "brissance" of the process is not decreased, as might be expected, but increased. On the other hand, as soon as the precompressed material is used up so that the detonation front begins to propagate directly into previously undisturbed material, the detonation rate and effectiveness drop back to their normal values (Ref 3, p 130, Ref 22, p 11g and Ref 35)

Refs: 1) A.F. Belyaev, *ZhPriklKhim* **23**, 432-39 (1950); Engl transl entitled "The Ignition of Explosives and the Transition from Combustion to Detonation", Consultants

Bureau, New York, pp 451-58; CA **47**, 2987 (1953) 2) C.G. Dunkle, "Introduction to Theory of Detonation of Explosives", Lecture delivered at PicArns on Dec 13, 1955, pp 4-5 3) Dunkle's Syllabus (1957-1958), 99-100 & 130 (Development of detonation from deflagration) 4) L.N. Khitrin, "Fizika Gorennya i Vzryva" (Physics of Combustion and Explosion), IzdatMGU (1957) 5) Cook (1958), 183-94 (Deflagration to detonation transition) (abbr DDT) 6) A. Maček, "Transition from Slow Burning to Detonation, A Model for Shock Formation in a Deflagrating Solid", NOLNavOrdRept **6105** (1958) 7) M.A. Cook et al, *PrRoySoc* **246A**, 281-83 (July 1958) (Deflagration to detonation transition in solid and liquid explosives) 8) S.R. Brinkley, Jr & B. Lewis, "On the Transition from Deflagration to Detonation", 7thSympCombstrn (1958) (Pub'd 1959), pp 807-11 9) G.K. Adams & D.C. Pack, "Some Observations on the Problem of Transition between Deflagration and Detonation", *Ibid*, pp 812-19 10a) M.A. Cook et al, "Deflagration to Detonation Transition", *Ibid*, pp 820-36 10b) M.A. Cook & D.H. Pack, *JApplPhys* **30**, 1579-84 (1959) [Investigation of transition from deflgrn to deton by means of "SPHF (Shock-Pass-Heat-Filter) Plate Test"] 10c) A. Maček, *JChemPhys* **31**, 162-67 (1959) (Transition from deflgrn to deton in cast expls) 11) Baum, Stanyukovich & Shekhter (1959), 417-22 (Transition of burning to detonation in gases); 422-28 (Transition of burning to detonation in condensed explosives) 12a) F.C. Gibson, C.R. Summers & F.H. Scott, "Studies on Deflagration to Detonation", USBurMines, Pittsburgh, Pa, Annual Summary Rept **No 3769**, Jan 1, 1959 to Dec 31, 1959. Office of the Secretary of Defense, ARPA (Advanced Research Project Agency), Order Nos 44-59 and 44-61, July 16, 1962 12b) *Ibid*, Summary Rept No **3863**, covering Progress Repts from Jan 1, 1959 to Dec 31, 1961 13) F.C. Gibson et al, *RevSciInstr* **30**, 916-19 (1959) (A method for the study of deflagration to detonation transition. Determination of velocities by the resistance probe) 14) C.T. Zovko & A. Maček, "A Computation Treatment of the

- Transition from Deflagration to Detonation in Solids", 3rdONRSympDeton(1960), pp 606-34 15) S. Wachtell & C.E. McKnight, "A Method for Determination of Detonability of Propellants and Explosives", Ibid, pp 635-58 16) A.B. Amster et al, RevSciInstr **31**, 188-92(1960) (Continuous oscillographic method for measuring the velocity and conductivity of stable and transient shocks in solid cast explosives) 17) Zel'dovich & Kompaneets(1960), 191-205 (Combustion and deflagration to detonation transition) 18) Andreev & Belyaev(1960), 141-44 (Transition of combustion to detonation in gases); 193 (Transition of combustion to detonation in condensed explosives) 19) N. Griffiths & G.M. Groocock, JCS **1960**, 4154-62 & CA **55**, 6865 (1961) (Transition from combustion to detonation of solid HE's) 20) R.W. Gibson & A. Maček, "Flame Fronts and Compression Waves During Transition from Deflagration to Detonation in Solids", 8th-SympCombstn(1960) (Pub'd 1962), pp 847-54 & CA **57**, 6198(1962) 21) K.K. Andreev et al, DoklAkadNauk **137**, 130-33(1961) & CA **57**, 4919(1962) (Burning of mixts of LA & liq org nitrates) 22) Dunkle's Syllabus (1960-1961), pp 9a to 9e (Development of detonation from deflagration. Combustion waves); 10a to 10g (Development of deton from deflgrn. Initiation of deflgrn); 11a to 11i (Development of deton from deflgrn. Detonation in gases) 23) W.H. Andersen & R.F. Chaiken, AmerRocketSoc-J **31**, 1379-87(1961) (Transition to detonation) 24) R.I. Soloukhin, ZhurPriklMekhan i TekhnFiz **1961**, No 4, 128-32 & CA **56**, 3713(1962) (Transition from burning to detonation) 25) K.K. Andreev, Explosivstoffe, **10**, 203-10(1962) & CA **58**, 3263(1963) (Thermal decomposition and combustion processes of explosives) 26a) Vlad Sima, TechChem(Prague) **12**(2), 66-9(1962) & CA **61**, 526(1964) (Determination of the degree of danger in explosives plants) 26b) A. Maček, ChemRevs **62**, 50-2(1962) (Deflagration to detonation transition) 27) K.K. Andreev & V.V. Gorbunov, ZhFizKhim **37**, 1958-65(1963) & CA **59**, 15113-14(1963) (Combustion-expln transition of expls. II. Stability of normal combustion of powdered expls) 28) K.K. Andreev et al, "Teoriya Vzryvchatykh Veshchestv. Sbornik Statey" (Theory of Explosive Substances. Collection of Papers), Oborongiz, Moscow(1963) (Transition from burning to detonation in powdered explosives) 29) J. Hershkovitz, "The Combustion of Potassium Perchlorate and Aluminum Considered Either a Deflagration or Detonation", PATR **3063**(1963) 30) V.K. Bobolev (Bobylev) et al, ZhPrikl-Mekhan i TekhnFiz **1963**(4), 99-101 & CA **59**, 13762(1963) (Transition from normal burning to detonation in porous explosives under conditions of slowly increasing pressure) 31) I. Shanfield, NASA Accession No **N65-36549**, Rept No **MERL-TN-64-2 (GD-22)**, 122 pp(1964); SciTechAerospaceRept **3**(24), 4249(1965) & CA **66**, 8180-R(1967) (Combustion, deflagration and transition to detonation in a cylindrical container investigated with a streak camera) 32) V. Lindner, "The Transition from Burning to Detonation", in Kirk & Othmer's Encyclopedia, Vol **8** (1965), pp 667-68 33) M.A. Cook & T.Z. Gwyther, NASA Accession No **N66-23949**, Rept No **AD 629239**, 15 pp(1965) (Eng); SciTechAerospaceRept **4**(13), 2472(1966) & CA **66**, 9117(1967) (Influence of electrical field on shock of detonation transition) 34) PATR **2700**, Vol 3(1966). pp D38-L to D40-L and Refs 5, 7, 9, 11, 12, 13, 14 & 15 listed on p D40-L 35) C.G. Dunkle, Silver Spring, Md; private communication, Jan 1968
- Detonation in Dilute Sprays.* Title of the paper by F.A. Williams, pp 99-114 in the book of Penner & Williams (1962), 8 refs
- Detonation (and Explosion), Distant Effect of.** Under the title "Distant Effect of Detonation", Dr G.R. Loehr [PicArns Translation No 5 (1956)] translated from the German the paper by A. Haid entitled "Die Fernwirkung von Detonationen" in Explosivstoffe **3**, 139-44 (1955). The paper deals with the following subjects: a) Formation of a compression shock wave b) Properties of shock waves c) Destructive effect of shock waves

d) Propagation of shock waves e) Measurements of shock waves f) Determination of pressure vs distance and g) Audibility of shock waves

[See also Detonation (and Explosion) by Influence]

Detonation and Explosion of Dusts, Mists, and Vapors.

Dust may be defined as suspension in air or other gases, of small solid particles ranging from ca 0.05 to 1000 microns in size. *Mist* is usually water or other liq in the form of particles floating or falling in the atmosphere. *Vapor* is a term applied to a gas that is at a temp below its critical temp, which can, therefore, be condensed by pressure alone

Some dusts, mists and vapors are combustible and when mixed with air in certain proportions they form combustible or explosive mixtures

As examples of combustible dusts may be cited suspension in air of finely divided particles of metals (such as Mg, Al, Zr, Zn, Fe, Ti, Mn, Ni, Co, etc, which can form in plants polishing metals or in plants manufg pyrotechnics); suspensions of finely divided coal, coke or charcoal; suspension of finely divided cereals (such as of flour, rice, oats, starch, etc); suspension of wood dust; suspension of sugar dust; suspension of explosive particles (such as of TNT, PA, Tetryl, etc)

As examples of vapors may be cited those of petroleum hydrocarbons in petroleum refining plants, vapors of solvents (such as alcohol, ether, acetone, carbon tetrachloride, carbon disulfide, etc used in plants manufg expls and proplnts); vapors of liquid expls (such as DNB, DNT, NG, NGc, DEGDN, etc), and vapors of liquids (such as benzene, toluene or xylene) used as primary materials in the manuf of expls such as TNB, TNT or TNX. Some solid expls such as TNT evolve, when in molten condition, explosive vapors

Many dusts and mists formed during manufg processes (particularly those formed in explosives plants) are not only explosive, but also toxic. They must be removed from the air as soon as possible. Methods for re-

moving dusts and vapors from the air or other gases are described in books on ventilation, air-conditioning, industrial hygiene, toxicology, etc

Explosion of coal dusts in mines is described in Vol 3 of Encycl, pp C358 & C359 under "Coal Dust and Its Uses" and "Coal Dust: Explosion Hazards from Its Uses". Its explns, especially in mixtures with fire-damp, are discussed on pp C360-R to C367-R under "Coal Mines Explosions and Fires", where numerous refs are given

Laws governing explosion (and detonation) properties of dusts and vapors are the same as for "nonideal" gases (See under "Detonation and Explosion of Gases")

As was stated here under "Burning (Combustion) and Deflagration of Gases, Vapors and Dusts", mixtures of combustible dusts and combustible liquids with air or oxygen may burn when unconfined, but they explode (or detonate) when under confinement. This means that tables 1a and 2 giving combustion limits for mixtures with air of combustible volatile liquids and combustible dusts can be used as explosion (or detonation) limits, provided the mixtures are confined. The same reasoning applies to table 1b, which gives combustion limits for mixtures of some liquids with oxygen. Table 1a is an abbreviated version taken from tables on pp 529-31 of Ref 40; Table 1b is taken from table on p 531 and Table 2 is an abbreviated version of Table 4 given on p 152 of Ref 40. Lower limits of concn for explosions of dusts in air are given in Ref 10. Tables are not given here

Investigation of explosibility of various dusts conducted at the USBurMines (Ref 24) showed that Al, pure Fe, Mg, Ti, Zr, cornstarch & woodpulp are the most explosive, while Cu, Cr, Pb & carbon black are the least explosive; of medium explosibility are Sb, Cd, Sn, Zn, impure Fe & coal dusts. Comparison of explosive capacity of various dusts was conducted in Canada by Montgomery (Ref 44)

General discussions on dust explns are given in Refs 3, 6, 8, 11, 12, 13, 16, 17, 18, 19, 22, 23, 27, 28, 29, 33, 35, 38 & 39

Descriptions of explns given by various dusts are given in refs: 1 (aluminum), 4 (hard rubber), 5 (organic materials), 7 (Al-bronze),

9 (starch), 14 (wood, charcoal, Al), 15 (agricultural products), 20 (flour), 21 (powdered metals), 26 (plastics), 30 (sugar), 36 (natural fuels), 41 (agricultural products), 42 (plastics), 45 (sulfides), 49 (iron powder), 51 (metal powders) and 52 (carbonaceous materials)

Methods of prevention of dust explns are discussed in Refs 2, 13, 14, 16, 22, 25, 31, 34 & 48

Methods of testing explosibility of dust-air mixtures are discussed in Refs 39, 50, 53 & 54

Review of literature on dust explns is given in refs 43 & 47

In Ref 46 are listed several papers on dust explns, which were discussed in 1963 at the Pennsylvania State University

Action of an explosive on surrounding nonreactive metal dust was investigated by Hershkowitz at PicArson (Ref 37)

Refs: 1) D.J. Price, *ChemMetEngrg* **23**, 915-19(1920) & *CA* **14**, 176(1920) (A disastrous expln of Al dust) 2) D.J. Price, *Ibid* **24**, 29-32(1921) & *CA* **15**, 598(1921) (Engineering problems in dust explns prevention) 3) D.J. Price, *Ibid* **24**, 473-75(1921) & *CA* **15**, 1401(1921) (Dust explosions) 4) D.J. Price & H.R. Brown, *Ibid* **24**, 737-40(1921) & *CA* **15**, 2358(1921) (An explosion of hard rubber dust) 5) P. Beyersdorfer, *Ber* **55B**, 2568-96(1922) & *CA* **17**, 1144(1923) (Conceptions regarding the expln of various organic dusts) 6) D.J. Price, *ChemMetEngrg* **28**, 902-03(1923) & *CA* **17**, 2362(1923) (Preventing dust fires and explns) 7) D.J. Price & R.W. Baker, *Ibid* **29**, 878-82(1923) (Aluminum-bronze dust expln in Richmond, Va) 8) W.E. Gibbs, *ChemAge(London)* **8**, 54-8 & 92-4(1923) & *CA* **17**, 2364(1923) (The problem of dust explns in industry) 9) G.E. Chamberlain, *ChemAge (NY)* **32**, 95-7(1924) & *CA* **18**, 2251(1924) (Starch dust explns) 10) L.J. Trostel & H.W. Frevert, *ChemMetEngrg* **30**, 141-46(1924) (Lower limits of concn for explns of dusts in air) 11) H.R. Brown, *IEC* **17**, 902-04(1925) (Dust explns in industry) 12) P. Beyersdorfer, "Staub-Explosionen", Steinkopf, Dresden-Leipzig(1925) 13) D.J. Price, *SafetyEngr* **70**, 144(1935) (Causes and prevention of dust explns and dust fires in industrial plants) 14) D.J. Price, *Quart-*

Nat'l Fire Protection Assoc **28**, 153-88(1934) & *CA* **29**, 346(1935) (Lessons from some recent dust explns, such as of wood, wheat, corn, feed, charcoal, aluminum, etc) 15) P.J. Edwards & L.R. Leinbach, *USDeptAgrTech-Bull* **490**, 24 pp(1935) & *CA* **31**, 2010(1935) (Explosibility of agricultural and other dusts) 16) W. Matla, *Rec* **55**, 173-91(1936) & *CA* **30**, 4323(1936) (Discussion on mechanism of dust explns and their prevention by the use of non-combustible dusts) 17) P. Drinker & T. Hatch, "Industrial Dust", McGraw-Hill, NY(1936) 18) Thorpe **4**(1940), 94-108 (Dust explns) 19) M.G. Gozhello, *Khim-ReferatZhur* **1940**(4), 129 & *CA* **36**, 3669(1942) (Dust explns in various industries) 20) S.E. Petrov, *Ibid*, **1940**(4), 129-30 (Dust explns particularly in flour mills) 21) H.R. Brown, *USBurMinesCirc* **7183**, 7 pp(1941) (Dust expln hazards from some powdered metals) 22) J.B. Ficklen, *JChemEducation* **19**, 131-34(1942) (A survey of types of dust explns, causes, prevention and control) 23) S.C. Blacktin, *ChemAge(London)* **47**, 53-7(1942) & *CA* **36**, 7320(1942) (Dust explns) 24) A.C. Fieldner & W.E. Rice, *USBurMines* **IC 7241**(1943) & *CA* **37**, 6844(1943) (Comparison of explosibility of various combustible dusts) 25) Anon, "National Fire Codes for the Prevention of Dust Explosions", Separate, 176 pp, published by the Nat'l Fire Protection Assoc, Boston, Mass (1944); *CA* **39**, 1294(1945) 26) I. Hartmann & J. Nagy, *USBurMines* **RI 3751**, 38 pp(1944) (Flammability and explosibility of powders used in plastics industry) 27) H.R. Brown, *USBurMines* **IC 7309**(1945) (Industrial dust explns) 28) S.G. Lipsett, *CanChemProcessInds* **30**(3), 41-6 & 48; *CA* **40**, 3665(1946) (Causes and factors involved in gaseous and dust explosion) 29) Kirk & Othmer **5**(1950), 309-13 (Dust explns) 30) R. Meck & J. Dallavale, *IEC* **46**, 763-66(1954) & *CA* **48**, 7303(1954) (Sugar dust explns) 31) A. Langhans, Abstract in *Explosivst* **1956**, 166 (Dust explns and ways of preventing) 32) A. Langhans, Abstract in *Ibid* **1956**, 93 & 266 (An investigation of the charge of whirling dust clouds with regard to the possibility of auto-ignitions or dust explosions) 33) H. Hanel, *Technik* **11**, 785-92(1956) &

CA 51, 6157 (1957) (Flammability and expln danger of various dusts) 34) Anon, "Report of Important Dust Explosions", Natl-FireProtectiveAssn, Boston (1956), 84 pp; CA 51, 12494 (1957) 35) J. Hartmann, ChemEngProgress 53, 121M to 124M (1957) & CA 51, 7013 (1957) (Recent findings on dust explns) 36) S.L. Shagalova, Teploenergetika 4(2), 16-20 (1957) & CA 51, 10867 (1957) (The factors influencing the origin of dust explns of natural fuels) 37) J. Hershkowitz, "Action of an Explosive on Surrounding Non-reacting Metal Dust", PATR 2484 (1957) 38) G. Schneider, AnnMines, No 11, 77-92 (1958) & CA 52, 11425 (1958) (Combustion phenomena in dust explns) 39) K.C. Brown & R.H. Essenhigh, "Safety in Mines. Research Establishment Report No 165, 23 pp (1959) & CA 54, 7149 (1960) (Dust explns in factories; new vertical tube test apparatus) 40) Andreev & Belyaev (1960), 148-53 (Burning and expln of dust-air mixtures); 529-31 (Burning and expln of volatile liquids-air mixts); 531 (Burning and expln of liquids-oxygen mixts) 41) M. Jacobson, Jr, et al, "USBurMines RI 5753 (1961) (Explosibility of agricultural dusts) 42) M. Jacobson, Jr et al, USBurMines RI 5971 (1962) (Explosibility of dusts used in the plastics industry) 43) K.C. Brown & G.J. James, "Dust Explosions in Factories. A Review of the Literature", Sheffield, England, SMRE, Ministry of Power (1962), 744 pp; CA 58, 5447 (1963) 44) W.J. Montgomery, "Comparison of the Explosive Capacity of Dusts", CanMiningMetBull 55, 765-67 (1962); CA 61, 11840 (1964) 45) N.S. Bakharevich et al, VoennoyeDeloNauchnoTekhnGoronye-Obshchestvo, Sbornik 1962 (49/6), 190-92 (Two permissible explns developed for mines with hazardous sulfide dust); CA 59, 3710-11 (1963) 46) R.H. Essenhigh, Pennsylvania-StateUniv, MineralIndsExptlSta, Circ No 64, pp 1-6 (1963) (An appraisal of dust explosion research); "Activities of the Instrument Society of America Subcommittee on Electrical-Dust Hazards", by T.W. Moodie, Ibid 27-32: "Proposals for Experiments on Dust Explosions" by P. Lafitte & R. Delbourgo, Ibid, 19-21. "The Dust Explosion Hazard", by D.S. Kingery & John Nagy, Ibid, 16-18. "Pioneer-

ing in the Study of Dust Explosions" by H.R. Brown, Ibid, 10-15 47) Anon, Bibliography on Dust Explosions, 1946-1963; USBurMines, Dec 1963 48) A. Narjes, Zement-Kalk-Gips 16(9), 357-63 (1963) (Prevention of coal dust explosions by use of inert gas); CA 60, 1528-32 (1964) 49) Yu.M. Gorokhov, PoroshkovayaMetAkadNaukUkrSSR 4(1), 105-10 (1964) (Combustibility and explosion hazard of powder and dust from iron and its compounds); CA 61, 527 (1964) 50) R.F. Schwab & D.F. Othmer, ChemProcessEng 45(4), 165-74 (1964) (A dust-explosion test app is described and exptl data are reported) 51) M. Jacobson et al, USBurMines RI 6516 (1964) (Explosibility of metal powders) 52) J. Nagy et al, USBurMines RI 6597 (1965) (Explosibility of carbonaceous dusts) 53) J.P. Gillis, InstEnvironSciAnnuTechMeet, Proc 1965, 481-84 (Expl characteristics of dusts were detd by igniting dust sample enclosed in a test vessel by means of an electric spark); CA 66, 9994 (1967) 54) N. Helwig, Staub, Reinhaltung Luft 27(2), 98-101 (1967) (Experiments were carried out at Dortmund-Derne, Germany to determine optimum explosion temps and optimum particle sizes of various coal dusts); CA 67, 1295 (1967) 55) Kirk & Othmer, 2nd edit, Dust explns - not found

Detonation (and Explosion), Dying-Out of. See under Detonation, Attenuation, Break, Cutoff, Decay, etc

Detonation (and Explosion), Dynamics of.

A discussion on this subject is given in the following:

Refs: 1) E. Jouguet, "La Méchanique des Explosifs. Étude de Dynamique Chimique", Duin, Paris (1917) 2) O.E. Vlassov, "Osnovy Dinamiki Vzryva" (Elements of Dynamics of Explosion), IzdatVIA, Moscow (1945) 3) Ya.B. Zel'dovich, "Teoriya UdarnykhVoln i Vvedeniye v Gazodinamiku" (Theory of Detonation Waves and Introduction to Gasodynamics), IzdatAkadNauk, Moscow (1946) 4) G.I. Taylor, PrRoySoc 200A, 235-47 (1950) 5) Cook (1958), 61 (Dynamic adiabatic and Hugoniot curve) 6) Baum, Stanyukovich & Shekhter (1959), 144-81 (Elements of gas dynamics)

Detonation (and Explosion), Earthwaves from. Earthwaves from explosions (or detonations) of charges buried deeply in earth are briefly discussed in Vol 2 of Encycl, pp B182-R to B183-R under "Blast Effects in Air". More detailed description is given in the book of Robinson (1944), pp 36-9

Detonation (and Explosion), Edge Effect in. Its definition is given, together with definition of detonation head, at the end of the item entitled "Detonation (and Explosion) Initiation of Explosives and Shock Processes" Edge effect is also mentioned here under End Effect

Detonation (and Explosion), Effects of Blast and Shock Wave on Structures. As this subject was not discussed in Vol 2 of Encycl, under "BLAST EFFECTS IN AIR, EARTH AND WATER", pp B180-L to B184-R, there is given here a brief description as taken from the book of Robinson (1944), where it is described in detail on pp 45-53

An explosion or detonation produces both an air blast and a shock wave in the air. The air blast consists of the air in violent motion in a general direction away from the site of the expln and in a condition of extreme turbulence. This degree of turbulence may be imagined by estimating a "Reynolds Number" of it, devised by Engl scientist Osborne Reynolds (1842-1912), to describe the effect of velocity phenomena in connection with flow of liquids. If k is Reynolds Number, d =diameter of moving stream, u = its linear velocity, ρ =its density and η = its viscosity,

$$k = (dup) / \eta$$

Its value varies from unity or less for viscous liquids, to a million or more for the slip stream by the wings of a high-speed airplane. In the case of an expln, k might be as high as a billion and, since k for the propellant gases pouring thru the barrel of a gun on firing is only ca 25 million, it may be imagined how turbulent and therefore destructive the air blast from a detonation can be. However, destruction is great only at comparatively short distance from the source

of expln, because of the expansion of gases, which increases their volume as the cube of the distance traveled; decrease is also due to friction of air blast on coming in contact with stationary air and solid objects encountered on the way

At the same time as the air blast is driving outward, the shock or pressure wave is moving radially from the expln site. This motion is strictly radial (in contrast to the turbulence of the air blast), except as it is reflected from solid surfaces or is changed in direction by impingement against some stationary bodies. This shock wave causes no appreciable motion in the air thru which it travels any more than a sound wave does when it travels thru the air. It consists of radial pressure push, followed immediately by a radial push backwards toward the expl, so that the pressure wave is followed by a suction wave. Following that, there may be a second, less violent suction wave. The subsequent waves appear to be damped out almost completely. When this shock pressure wave hits a solid obstacle, it applies a pressure to the surface against which it impinges. If this surface is flat, rigid and at right angle to the direction of travel of the wave, the wave is reflected backward in a 180-degree arc and has no tendency to go around corners. On the other hand, if the surface is elastic, the pressure will push the surface ahead of it until the pressure dies away. Following it the suction phase of the wave will then drag the surface backward toward whence it came. If the surface is brittle, such as window glass, the shock pushes and shatters it, but before broken pieces can travel very far, the pressure wave changes to a suction wave, the push becomes pull, and the broken pieces are drawn out in the opposite direction. Since the suction phase always lasts for a longer time than the pressure phase, the pieces are drawn back to a position in front of their original one, that is, nearer the expln site, giving the impression that the window blew out from an internal expln. The effect on the wall or roof of a building against which the shock wave impinges is the same as in the case of a window. If the building faces

the expln site, it is subjected first to a violent push of very short duration, which might bulge the wall and roof inward without breaking them or it might cause partial or complete destruction. If the building survives the push, it might be destroyed by the pull created by the suction wave, which is always of a longer duration. If the bldg is near enough to be caught in the air blast (which has no suction phase), the walls and roof may be shattered by the violence of the shock wave and the pieces are then picked up by the air blast and hurled away from the scene, becoming missiles and traveling sometimes great distances

The push of an expln against a wall is the product of the pressure times the time of duration of the push. This product is called *impulse* and can be expressed as:

$$I = \int_{\theta_1}^{\theta_2} P d\theta$$

where: I = impulse

P = pressure

θ = time

Impulse is the most important factor in determining the resulting behavior of the wall. Method of its calcn is given on pp 48-52 of Robinson's book

In addn to the distance of the structure from the expln, the vibration period or frequency of the structure affects its behavior in a blast. The nearer the frequency of the structure to that of the shock wave, the more likely it is to vibrate in sympathy with it and therefore to suffer more damage. Since most buildings vibrate betw 1 and 10 vibrations per second and the frequency of violent explns is usually greater than 10, the damage from shock waves due to sympathetic vibrations is not likely to be great

Robinson, pp 52-3, lists relative resistances of various kinds of structural walls to blast from explns, arranging them in the approximate order of resistance, the most resistant being at the top:

- Thick reinforced concrete walls
- Thick brick or concrete walls
- Thin reinforced-concrete walls
- Thick earthen barricades

- Steel-frame building walls
- Well-built wooden-frame building walls
- Thin brick walls
- Wire-reinforced glass
- Unreinforced glass

Detonation (and Explosion), Effects of Boundary Rarefaction on Impulse Delivered by Explosive Charges. It was discussed in the paper presented by B.C. Taylor at the 3rdONR-SympDeton (1960), Vol 1, pp 267-84

Detonation (and Explosion), Effects of Inert Components on. It was discussed by J.L. Copp & A.R. Ubbelohde in TrFaradSoc **44**, 646-69(1948)

Detonation (and Explosion); Effects of the Physical Structure and the State of Aggregation on the Detonating Capacity of Explosives. It was discussed by A.Ya. Apin & V.K. Bobolev in ZhFizKhim **20**, 1367-70(1946). Engl abstract is in CA **41**, 3297(1947)

Detonation (and Explosion), Effects Produced in Air, Earth and Water. In addition to information given in Encycl, Vol 2, pp B180 to B184 under the title: "BLAST EFFECTS IN AIR, EARTH AND WATER" the following may be included:

C.G. Dunkle, in his Syllabus (Addnl Ref E), describes: Propagation of Detonation in Air Blasts (pp 313-15), Mach Waves (pp 315-17); and Blast Effects in Water and Earth (pp 317-18). In his private communication (Ref G), he suggests including the following:

"The shock wave in water results from the compression of the spherical layer of liquid in immediate contact with the high-pressure gas sphere produced by the detonation. This layer in turn compresses the next layer, and so on, so that a compression wave or shock wave is propagated radially outward thru the water. The shock wave has an extremely high pressure, but decays rapidly with distance and soon becomes an acoustic wave. Unlike a shock wave in air, the shock wave in water has no appreciable negative phase. While the compression wave is moving far outward, the original gas bubble continues

to expand and the gas pressure lowers to the hydrostatic pressure

The momentum of the water as it moves outward causes the gas bubble to over-expand so that its pressure drops below the hydrostatic pressure, and then to collapse as liquid flows back in. The return flow also overshoots; the gas pressure rises again, but to nowhere near the detonation pressure. However, the bubble expands again in rebound, behaving in effect as a second explosion. Several successive rebounds may occur, each becoming weaker. To evaluate the total damage, both the shock wave and the subsequent bubble pulses must be considered

Following are references which are additional to those already given on p B184 of Vol 2:

Addnl Refs: A) Collective, "Air Burst in Blast Bombs". A Compilation of Papers Presented at NDRC Div 2 Symposium, OSRD 4923 (1945) B) Collective, "Underground Explosion Test Program", Final Rept, Vol II, "Rock", Engineering Research Associates, Division of Remington Rand Inc, 30 April 1953 (Conf) (Not used as a source of information) C) G.R. Pickett, "Seismic Wave Propagation and Pressure Measurements Near Explosions", Quarterly of the Colorado School of Mines 50(4) (Oct 1955) D) W.E. Deal, "Shock Hugoniot in Air", JApplPhys 28, 782-84 (1957) E) Dunkle's Syllabus, Session 26, 23 Apr 1958, pp 313-18 F) Dunkle's Syllabus, Suppl to Section 26 (1961) G) Dunkle, private communication, Jan 1968

Detonation, Elastic Properties of Solid Materials in. See A.H. Eschenfelder in BRL (Ballistics Research Lab) Memo 521 (1950)

Detonation (and Explosion), Electrical, Electromagnetic and Magnetic Effects Accompanying It. In considering electrical effects accompanying deton or expln, it may be assumed that the high temps produced can result in formation of an abundance of charged particles moving at high velocities. The movement of these charged particles in the vicinity of a coil or wire should induce an EMF (elec-

tromotive force) in the coil that could be observed and recorded by an oscillograph with a single driven sweep having adequate time resolution

In investigation, at USBurMines (Ref 1), of various phenomena accompanying the detonation, it had been observed, initially, that electrical potentials were induced in single- and three-turn loops of wire around the charge. The records showed a smooth rise and fall of potential lasting a fraction of a microsecond, followed by an irregular series of oscillations at coil breakage which continued for more than 25 microsecs. The initial pip polarity depended on the direction of coil winding in the three-turn coils. A rectangular coil (1.5 x 2 cm) of one turn was placed with the long dimension against the side of the cylindrical chge and left closed for 6 microsecs after the appearance of the 1st generated EMF. The 1st pip on the trace showed that a measurable potential had been generated which was reproducible for 2 out of 3 tests. The coil was then moved into the chge, with the long dimension on the axis of the chge; it was disrupted before any measurable EMF appeared

Having thus established the existence of effects due to the motion of charged particles in the expl, the investigation was extended to addnl effects produced by the introduction of foreign materials into the chge. Magnetized steel phonograph needles were placed in and on the chge with pick-up loops of different sizes and inductances located along and below the chge. Tests were made with one-turn loops wrapped tightly around the chge and located at the top, center and bottom of magnetized needles completely surrounded by expl. With the loop at the bottom of the needle, a voltage-rise time (defined as the time required to reach the potential maximum prior to polarity reverse) of 2 microsecs was observed, whereas the other two positions were ineffective. As the effect was much stronger when the coil was at the lower end (the pole of the magnet farthest from the initiated end of the expl chge); tests were made on Tetryl of loading densities 1.23 & 1.62 g/cc, with 10-turn coils of the spider-web type, 2 inches

in diam, in which the turns were in the same plane. Displacements, related to the voltage generated, of 4 mm per microsec and 11 mm per microsec were obtained respectively for the two densities. The reason for these different values was difficult to explain, but it seems that such a difference was representative of the pressures developed in expls for the d 's indicated. It could be, however, safely stated that the magnetic effects were real, as evidenced by pole orientation and direction of coil winding, but it remained to be seen whether the potentials induced by the action of the expln on the magnetic field were due to the collapse of the field due to destruction of the magnet, propulsion of the magnet (or both), or approach to the magnet of deton wave, acting as a conducting medium

In later experiments when the needles were embedded near the boundary betw two adjacent Tetryl pellets of high and low d , the wave form took on the appearance of a trace corresponding to the d of the material surrounding the needle and not to the d of the preceding pellet, regardless of whether there was transition from low to high or from high to low d . This showed that the approach of the deton wave had little effect on the phenomenon

In some later experiments the shots were made with Alnico V magnets. Potentials produced in the pickup coil with these magnets were considerably higher than those with magnetized needles and a voltage pip of ca 0.4 microsec duration became discernible, closely followed by the major 2-microsec pip observed with needles. None of the Alnico magnets was recovered after deton, while some of the needles, which were imbedded in the chge with the end slightly protruding, were recovered fairly intact. Several tests were made using small nonmagnetized cylinders together with two coils having a large coefficient of coupling. One coil was energized by direct current, while the other coil acted as a pickup and was connected to the recording instrument. The resulting oscillograms were too complicated to analyze (Progr Repts April-June & July-Dec 1951)

In the ProgrRept Jan-March 1952 tests using Alnico V magnets of various sizes were

described. The effects produced by substituting an Alnico magnet for a magnetized needle were greater than anticipated. For example, with an Alnico magnet 16 mm in length and 3.3 mm in diam, the EMF induced in a 10-turn 3.5 cm diam pickup coil exceeded 1 volt. The magnet was cemented to the bottom of the charge, and coil held in position by means of non-metallic spacers. Inspection of the resulting oscillograms showed that the voltage rose uniformly for appr 0.1 microsec, at which time the rate of rise suddenly changed. With shorter magnets the discontinuity was less pronounced and when the magnet length was reduced to 3 mm, the polarity of the induced EMF was reversed completely. In addn, there was a measurable difference in the rate of rise in the induced EMF produced by detonating Tetryl at d 's of 1.6 & 1.2 g/cc, e.g. 2.6 volts/microsec and 0.8 v/microsec, respectively

In the ProgrRept April-June 1952 are described preliminary studies of the behavior of Alnico magnets and the EMF induced under impulsive motion and under more idealized conditions than those which accompany deton. Equipment was assembled and synchronization app developed which would permit display of resulting waveforms of the accelerating Alnico magnets. A rifle test was used to support and accurately direct the line of fire of a .22 cal Hornet rifle ball thru a 10-turn, 2-inch coil similar to those previously used. The magnet was supported on the coil axis and struck with the lead rifle ball. A double Al screen placed 5 mm in front of the magnet and coupled to a thyatron trigger unit, when pierced by the ball, served as an accurate sync device

In one set of experiments, the impulse was transmitted to the magnet thru brass or stainless steel buffers. The waveforms produced were nearly ideal and consisted of a small potential rise and fall followed by a polarity reversal. Short-duration photographs of these phenomena were taken but not included in the rept

In the Prog Rept July-Sept 1959 the following brief resumé of work done up to July 1952 is given: Currents were induced

in coils placed on and near exploding chges. When induced EMF's were analyzed, certain polarity effects were noted, but significant data could not be derived from the oscillograms produced due to waveform complexities. However, this study has led to an investigation of the feasibility of using a magnetic element system for evaluation of the forces associated with an expln. Small magnets have been imbedded in and attached to the expl chge. Pickup coils (in conjunction with magnets) which were positioned for optimum coupling to the magnet formed pressure transducers; the acceleration of these minute magnets could be detd from oscillograms which displayed an EMF-time relationship, provided that the impulse could be imparted to a sufficiently small magnetic element without disruption of the magnet. It was believed that this could be accomplished by use of buffer elements of a non-magnetic nature and of similar accoustic impedence. Trials using an idealized approach when the buffer was struck with a high-speed rifle bullet and the impulse transmitted to the magnet indicated this to be a feasible approach

A series of supplemental tests were made on chges comprised of a confined cylindrical 3/4-inch diam Tetryl pellet over which a square metal duct or tube was placed, with an oversize 1-5/8-inch diam pellet placed at each end as confinement for the shock tube; then the assembly end was initiated. These tests were made to det the fragment pattern effect using the tubes with or without fins. It was found that good fragment grouping could be obtd from the flat duct and that the rotation was somewhat dependent on whether the tube fins were radial or tangential. In the tests with finless tubes, chges were prepd with each duct composed of two brazed seam corners and two bent corners. This construction was employed to ascertain whether the corner strength entered into the fragment pattern. The tests showed that damage occurred broadside to the duct sides in a fairly well grouped fragment pattern having no slug effect and filling a solid angle of ca 20°. This was in contrast to deep slug penetra-

tion with the fin-type enclosure

Accdg to Pokrovskii (Ref 2), in explosions of even ordinary expls several electromagnetic processes take place. Particles of gases formed in the expln are highly charged and their fluxes move very irregularly in the expansion. Streams of gases carrying one charge may fly considerably forward, while the particles of opposite polarity will lag behind. The result is the appearance of electromagnetic fields alternating in space with consequent emission of powerful, though short-lived, electromagnetic impulse

Dunkle's Syllabus (Ref 7) gives a review of work done up to 1958, whereas in Syllabus (Ref 9) is given work done up to 1961. Following are some of the remarks:

- a) On p 387 of Ref 7: "It may be significant that the ions seem to result not from thermal processes but from chemical influences which cause abnormal electronic excitation. In any event, it is known that the *detonation head* is highly ionized. Electrons escape into the layer of explosive just ahead of the front by virtue of their greatly superior mobility, leaving the head positively charged
- b) On p 78 of Ref 7: R.M. Patrick & A. Kantrowitz [Proceedings of the First Gas Dynamics Symposium (Aerothermochemistry), Northwestern Univ, Aug 1955, pp 255-63] noted that in shock tube experiments with argon at Mach 7 to 20, after a short non-luminous interval behind the shock front, there appeared an intensely luminous zone behind the compressed gas. Ionization is considered merely a secondary effect, having no important influence on the mechanism of wave propagation. Yet the ionized gas forms a "conductive slug" and since its velocity is known, its conductivity can be detd from its effect on a steady magnetic field. Moreover, its high conductivity provides a means of pushing the shock wave ahead by successive field pulses
- c) In private communication, Dunkle wrote (Ref 15), that "Patrick & Kantrowitz took advantage of the conductivity of the slug of ionized gas behind the shock front in argon to accelerate the shock wave electrically"

d) On p 388 of Ref 7 it is stated that in later experiments Kantrowitz' group measured ion concentrations as high as 40% at 18000°K by determining the behavior of *plasma* in a magnetic field. It was reported by G.E. Duvall & M.C. Kells on p 56 of "Proceedings of the Symposium - High Temperature - A Tool for the Future", Sponsored by Stanford Res Inst, Univ of Calif, Berkeley, 25-27 June 1956

e) On p 388 of Ref 7 are described two experiments with tapered glass discharge tubes. In both experiments, the gas in the tube broke down and ionization started at the small end of the tube, with "pinching" of the partly ionized gas. The hot *plasma* heats and ionizes the adjacent gas before the latter is pinched, thus making it require more energy for pinching so that more energy is coupled into it. The process progresses along the tube with the resulting hot plasma mass driving a high-velocity shock into the viewing tube. Effects of a magnetic field on plasma have led to some interesting astrophysical speculations

f) On p 389 of Ref 7: "Control of the movement of plasma by influence of a magnetic field is an object of the new science of *magnetohydrodynamics*. Possibility of inhibiting thermal conduction in a plasma by such means offers hope of deriving power directly from controlled nuclear fission and even of reaching temperatures required for initiation of nuclear fission"

Note: Some of the books on "magnetohydrodynamics" are: T.G. Cowling, "Magnetohydrodynamics", Interscience, NY (1957); R.K.M. Landshoff, ed, "Magnetohydrodynamics," Symposium, Palo Alto, Calif, 1956, Stanford-Univ Press (Publ 1957); T. Watanabe, Can J Phys **39**, 1044-57 (1961) & CA **55**, 21803 (1961) (Hydromagnetic waves)

g) On p 14g of Ref 9 is discussed the work of Pokrovskii (See Ref 2) (spelled incorrectly by Dunkle as Petrovsky) on ball lightning and his note that electromagnetic processes occur even in an ordinary explosion. Particles formed in the explosion are highly charged and their fluxes vary irregularly in the expansion. For instance, streams having primarily one polarity may fly forward, while

particles of opposite polarity lag behind. The result is the appearance of electromagnetic fields alternating in space, with consequent emission of powerful though short-lived electromagnetic impulses

Recently, much effort has been devoted to the measurement and explanation of the electrical conductivity of the detonation zone. At the 10th Symp Combstn (Ref 12), B.G. Craig, pp 863-67, presented data suggesting the possibility of deposition of carbon in the detonation products. Measurements of the conductivity behind the detonation front in Comp B and two liquid expls [NMe (Nitromethane) & liq TNT] were reported by B. Hayes in Ref 12, pp 869-74. In NMe the average conductivity of the zone was about 150 mhos/meter, ca 20 times that of sea water and more than twice that of the strongest available electrolyte; in addition, a pronounced conductivity peak occurred at 1.5-2 nanoseconds after the detonation front. In Comp B the conductivity peak was nearly an order of magnitude higher, but did not occur until nearly 100 nanoseconds after the front; in addition a pronounced inflection occurred at about 7.5 nanoseconds. In liquid TNT the conductivity-time profile resembled that of Comp B in that a conductivity peak occurred preceded by an inflection region suggesting a reaction zone. However, the conductivity peak was again an order of magnitude higher than that of Comp B, and was actually only one order of magnitude below the conductivity of solid carbon at the same temperature

The vast differences among the three explosives were puzzling because their detonation pressures and temperatures are not vastly different. An explanation is suggested by the probable differences in carbon content of the detonation products. Since the calculated fractional carbon density for liquid TNT is about 26%, the good electrical conductivity is not surprising. In fact, the curve of the calculated free carbon content of the detonation products in grams/cc vs the log of the peak conductivity for the three explosives is a straight line [quite so for the Brinkley-Kistiakowsky-Wilson equation of

state, and almost so for the Lennard-Jones-Devonshire equation of state, listed under Detonation (and Explosion), Equations of State]. It can be extrapolated down to NG, for which there is only thermal-type conduction. Since the binding energy of carbon is not too great, charge conduction above this point can be due to the loosely bound or valence electrons available from the carbon (ionization potential 3-4 volts), and the bulk conductivity then depends mainly on the fractional carbon density

At the 4th ONRSympDeton (Ref 13) B. Hayes, pp 595-601, reported further progress in the measurement of electrical conductivity behind the detonation front. He had succeeded in his final goal, the measurement of reaction zone structure, thru an improvement in time resolution, from a few tenths of a microsecond to a few tenths of a nanosecond. This improvement made it possible to resolve micron distances behind the front. The value of the peak conductivity was found to correlate so strongly with the amount of solid carbon present in the detonation products, as to suggest that the principal path of electrical conduction in that region is thru a continuous network of solid carbon

If the high conductivities were a temperature effect, as has been suggested, the conductivity in the detonation products of PETN should be highest at low charge densities, for here the temperature is highest. Yet the conductivity is lowest at these densities, where the carbon is in the form of CO gas and no solid carbon is present

At the same symposium J.R. Travis (Ref 13, pp 609-15) reported the generation of electrical signals by initiation processes in dielectric liquid explosives. A transducer utilizing this effect was developed, and found by comparison with smear camera records to measure accurately the time of events during the initiation process. The transducer is particularly useful for explosives in which, because of low luminosity, the entire initiation process cannot be followed with a smear camera. The source of the electric signals was not known, but a suggested cause was polarization by mechanical orientation of de-

formations of the molecules within the thickness of the shock front. The following hypothetical model was proposed:

"The initial shock wave on entering the liquid explosive polarizes the molecules in a thin layer near the interface, producing an induced charge on the plates of the transducer. As the shock traverses the liquid it continues to polarize a thin layer of molecules, but the polarization behind the front relaxes rapidly. Since no additional charge is induced on the plates, the output drops to zero. When detonation starts at the attenuator interface, a newly polarized layer induces additional charge on the plates, giving rise to the second observed pulse. Chemical reaction occurring just behind the front in the compressed explosive destroys the polarization, but the reaction products form a conductive path between the detonation front and the grounded attenuator plate. The output pulse drops, but charge continues to flow in the external circuit because the electrode spacing is being reduced, and the electric field strength consequently increased by the increasing layer of conductive reaction products. When the detonation in the precompressed explosive overtakes the compression wave, the signal drops sharply in the negative direction, indicating a sudden reduction of the polarization between the electrodes, and the current reverses. Possibly the overdriven detonation, and the subsequent steady-state detonation, produce a less intense polarization than the initial compression wave, although in the same direction. This may indicate that decomposition (with little polarization) occurring at detonation pressures is a more rapid process than the polarizing deformation caused by the initiating shock. As the detonation wave nears the probe, the pulse rises rapidly because of the rapid increase of field strength with decrease of effective electrode spacing"

At the 11th SympCombstn (Ref 14), J.R. Kelly and T.Y. Toong, pp 657-64, reported measurements of the electrical conductivity of the detonation zone in unseeded gaseous explosions. Oxyacetylene detonation waves

were passed thru MHD-type (magnetohydrodynamics-type) channels having crossed transverse electric and magnetic fields.

The current density was comparatively high in the reaction zone because of chemi-ionization. The conducting slug lengthened as the electrode voltage was raised. With an applied potential of up to 600 volts the current increased linearly with the voltage according to Ohm's law. At voltages above 600, however, the current rose steeply from about 2 to over 6 amps, and continued to rise rapidly with further increase in voltage.

The effect increased with penetration of the wave front into the electric field. Addition of a magnetic field decreased the total current across the slug, by about 40% when the $j \times B$ force was in the direction of wave propagation, but by about 25% when the force was against this direction. There was no effect on the wave speed unless the $j \times B$ force was against the flow, in which case the wave speed was lowered by up to 10% on account of an increase of turbulence in the boundary layer. The changes in wave structure observed were attributed to the "Hall Effect"

The *Hall Effect*, in magnetohydrodynamics (MHD), rotates the current vector away from the direction of the electric field and generally reduces the level of the force that the magnetic field exerts on the flow. It is usually measured by the parameter $\omega\tau$, where $\omega = eB/m$ is the angular velocity of the electron orbits around the field lines, and τ is the mean time between scattering collisions for the electrons. The form of Ohm's law which accounts for the Hall Effect (See Ref 2a) is:

$$j = \sigma(E + v \times B) - (e\tau/m)j \times B,$$

where: j = Current density in emu

E = Electric field strength in emu

B = Magnetic field strength in gauss

τ = Decay time for magnetic field

σ = Charge density in emu

v = Macroscopic velocity

e = Charge of proton, 4.803×10^{-10} esu

m = Particle mass in grams

[The foregoing is the 1st paragraph and equation (1) of "A Simple MHD Flow with Hall

Effect", by R.H. Levy in Ref 11, p 698-99]. This note describes a simple flow in which the Hall currents can be calculated exactly and the results compared with those that follow from the usual simplifying assumptions of reducing in fixed ratios the conductivities parallel and perpendicular to the field lines

Dunkle notes (Ref 15) that one of the recent works described a *deceleration* of the detonation wave in oxy-acetylene mixtures by crossed electric and magnetic fields, which makes an interesting comparison with the *acceleration* of the shock wave in argon electrically as reported by R.M. Patrick & A. Kantrowitz (mentioned by Dunkle in Ref 7, p 388)

For more information on the subject, see the following refs:

- Refs: 1) C.M. Mason et al, "The Physics and Chemistry of Explosive Phenomena", USBurMines, Pittsburgh, Pa, ProgressRepts April-June 1951, Contract NA onr 29-48, Project NR 053 047; Ibid, July-Dec 1951, Jan-Mar & Apr-June 1952; Contract NA onr 29-48, Proj NR 357 047; Ibid, July-Sept 1952, OrdnProj TA3-5001 2) G.I. Pokrovskii, "Vzryv" (Explosion), VoenIzdatMinistOborony, Moskva (1954); Engl excerpt by Maj G.K. Kudravetz, USAirIntelligenceInfoRept IR-1329-58, OTIA 1450 (1958) (See also in the text) 2a) L. Spitzer, Jr, "Physics of Fully Ionized Gases", Interscience, NY (1956) 3) F.E. Boyd et al, "Instrumentation for Measurement of Electromagnetic Propagation Through Flames", NRL 487 (1956) 4) K. Watanabe, JChemPhys 26, 542-47 (1957) (Determination of ionization potentials of 89 molecules) 5) W.W. Belevary, "Interaction Between Electromagnetic Waves and Flames", Part 5: 'Sources of Ionization in Rocket Exhaust', NOTS 1708 (1957) (Conf) (Not used as a source of info) 6) J. Deckers & A. van Tiggelen, Nature 182, 863 (1958) (Identity of ions in some flames) 6a) S. Basu & J.A. Fay, "Ionization in Detonation Waves", 7thSympCombstn (1958) pp 277-82 7) Dunkle's Syllabus (1957-1958), pp 387-89 ("Effects of the Ionization in the Shock Front") (Review of previous work on this subject) (See

in the text) 8) Cook (1958), 27-8 (Electro-optical effects accompanying detonation); 143-71 (Ionization, electrical, magnetic, and electromagnetic phenomena accompanying detonation) (12 refs are included) 9) Dunkle's Syllabus (1960-1961), p 10d (Review of works listed here as refs 3, 4, 5 & 6); p 14g (Review of work of Pokrovskii, listed here as Ref 2) 10) R.D. Keyes, "Electrical and Plasma Phenomena Accompanying Detonation", Utah Univ Report, Contract AF 49(638)-1061 Oct 1961-Sept 1962 11) R.H. Levy, AIAAJ (Am Inst of Aeronautics and Astronautics Journal) Vol 1, pp 698-99 (March 1963) (A Simple MHD Flow with Hall Effect) 11a) R.L. Jameson et al, "Electrical Resistivity Measurements in Detonating Composition B and Pentolite", JApplPhys 35, 714 (1964) 12) 10thSympCombstn(1964), papers and pp indicated in the text 13) 4thONR-SympDetonation (1965), papers & pp indicated in the text, except: 13a) Per-Anders-Persson et al, "A Technique for Detailed Time-Resolved Radiation Measurements in the Reaction Zone of Condensed Explosives", pp 602-08 14) 11thSympCombstn(1967) - papers and pp are indicated in the text 15) C.G. Dunkle, private communication, Jan 1968 16) P.P. Wegener & G.D. Stein, "Light Scattering Experiments and Theory of Homogeneous Nucleation in Condensed Supersonic Flow", 12thSympCombstn(1968) (Pub 1969), pp 1183-91

Detonation, Electromagnetic Radiation from.
See Cook (1958), pp 159ff

Detonation, End Effect in. Accdg to Cook (1958), pp 97-9, the end effect is "the impulse loading of a target at the end of a cylindrical charge". It has been shown by many experiments involving end effect, that a steady-state detonation head is developed in all condensed expls, whether confined or not. For example, it was found that total momentum and energy of jets from shaped charges (as measured by hole volumes and depths of penetration in homogeneous targets) increased with the length of the chge up to ca 3 to 4 chge diameters in the most heavily confined chges. Beyond this optimum or maximum ef-

fective length L_m , no further end effect was observed. This has been shown also by other tests, such as lead block compression, gap tests, etc. The maximum effective length was about the same for all unconfined chges of condensed expls (L_m ca 3.5d), whether of high or low density

The end effect for charges of $L/d \geq 3.5$ has also been shown in shaped-charge and other studies to vary ca as the cube of the effective diam d^1 of the charge which takes into consideration a small *edge effect* (qv)

Investigation of the influence of confinement on the total end effect, has shown that in the range of diameters between ca 1.5 and 2 inches, the maximum effective confinement obtainable with steel was reached with a tube ca 0.5 inches thick. Also, it was found that with maximum confinement the effective charge length L_m in this range of diameters increased only ca one charge diameter above that of unconfined charges, while the total end effect about doubled

Detonation, Energetics and Thermochemistry of.
See Detonation, Thermochemistry and Energetics

Detonation (and Explosion), Energy of. The energy of detonation (or explosion) is the total energy evolved in the process, and may appear either as heat or some other form of energy such as mechanical work; the proportion of each depends on conditions, but the sum of all forms is rigorously constant. This sum is often called the *heat of detonation (or explosion)*; for purposes of measurement it is usually converted to heat, but in practical applications appears in other forms as well

The energy obtained from an explosive exists, in potential form, as the binding energy of chemical bonds. Such bonds in even an inert compound can be broken on absorption of at least the binding energy, but such breakage in an explosive leads to formation of new bonds with release of a greater quantity of energy. The net evolution of energy is therefore positive

The heat of detonation is given by deducting the heat of formation of the explosive

from that of the mixture of products as formed at the Chapman-Jouguet (C-J) point, where they are still hot and at high pressure. Interaction beyond this point is prevented, so far as possible, by strong confinement which keeps the pressures higher and thus allows faster cooling; also the products work against resistance by shattering a steel capsule within the bomb while still at high pressure. This, too, speeds cooling and "freezing" of the chemical equilibria at their "high-pressure" values. In a determination of heat of explosion, on the other hand, pressure drops quickly from detonation values, but temperature stays high longer because the products make only a free expansion and so do no work. They thus have time to react and approach their low-pressure composition before the equilibria freeze. Both heats refer to the same standard temperature, e.g. 298° K, and can be corrected to give the standard enthalpy change on formation of the respective set of products from the explosive

As noted in the 1st paragraph above, the mechanical work which is performed upon the environment when an explosive is detonated (or exploded) depends on conditions, and is much more difficult to define. Several methods for its determination were proposed, none of them very satisfactory (Refs 2, 3, 4, 5 and 14)

In a later paper of Jacobs (Ref 6), an attempt was made to determine energy by a semi-quantitative solution of a typical detonation problem using simplifying assumptions

Details of the energy distribution and a summation of the total energy released by a given quantity of explosive during one-dimensional detonation either in: 1) a rigid (non-expanding) cylinder of unit cross-section and of unit length closed at each end with rigid closures, thus giving a closed bomb of constant volume or 2) a rigid cylinder of unit cross-section and of unit length closed at one end with a rigid cover and provided at the other end with a piston

In the first model there will be a sudden rise to the detonation pressure as the wave progresses, followed by spreading rarefaction

and, because the confining walls and closures have not moved, the external work done by the products of expln is zero. Inside the container the pressure, density and particle velocity will be distributed, as shown by Taylor (Ref 1), in a simple (or progressive) rarefaction wave. Calculation (which is not shown here) gave for the average energy (e_o) released by the chemical reaction per gram, the following value:

$$e_o = p_1 / 2\rho_o(\gamma-1),$$

where: p_1 = the CJ (Chapman-Jouguet) pressure
 ρ_o = the initial loading density
 γ = the constant, in this case ca 3

In the second model, where the piston follows the gaseous products of detonation to maintain a constant pressure in the container and no expansion of the gas takes place, pressure, density and particle velocities are uniformly distributed in the space betw the piston and rigid closure and the work has now been done on the gas by the piston. The same formula as above is applied also in here

Following are values of p_1 , ρ_o , γ and e_o for some expls:

Table

| Explosive | p_1 in kilobars | ρ_o in g/cc | γ (computed) | e_o in kcal/g | Refs |
|----------------|-------------------|------------------|---------------------|-----------------|-------|
| RDX | 325 | 1.762 | 3.03 | 1.083 | 3 & 6 |
| TNT | 178 | 1.640 | 2.762 | 0.530 | 3 & 6 |
| 77/23-Cyclotol | 313 | 1.743 | 2.790 | 1.200 | 3 & 6 |
| Comp B | 272 | 1.67 | 2.825 | 1.067 | 4 & 6 |
| Comp B | 293 | 1.712 | 2.762 | 1.16 | 3 & 6 |

There are two thermodynamic concepts which may be mentioned in connection with energy. One of them is **enthalpy** (designated as H) and equal to $E + pv$, where E is the energy, p = pressure and v = volume, while the other is **entropy** (designated as S). The entropy (which is expressed in cal/degree) depends on the internal and unavailable energy of a system (expressed in cal/g) and its temperature. It is the infinitesimal heat (q) taken up in a reversible, isothermal pro-

cess, divided by the absolute temperature (T). Enthalpy (known also as "heat content") is expressed in cal/g. For the entire change in the system, the change in entropy is equal to the summation of the infinitesimal terms as designated by the expression:

$$\Delta S = \int dq / T$$

At absolute zero the entropy of the system is zero (Refs 1a, p 265; 7, pp 359-61; 9, pp 67-8 & 10, pp 25-L & 46-L) [See also Critical Energy of Impact in Detonation (and Explosion) and Detonation (and Explosion) Energy Relationships in]

Refs: 1) G.I. Taylor, *PrRoySoc* **200A**, 235-47 (1950) 1a) "The VanNostrand Chemists' Dictionary", VanNostrand, NY(1953), p 263-65 2) W. Noddack & E. Grosch, *ZElektrochem* **57**, 632-36(1953) & *CA* **49**, 8601-02 (1955) (Energy measurements in explosion of primers) 3) W.E. Deal, Jr, p 209 in *2ndONRSympDeton*(1955) 4) R.E. Duff & E. Huston, p 225 in *2ndONRSympDeton*(1955) 4a) C.G. Dunkle, "Introduction to Theory of Detonation of Explosives", Lecture delivered at PicArsn on Dec 13, 1955 5) W. Fickett & R.D. Cowan, p 265 in *2ndONRSympDeton*(1955) & *JChemPhys* **24**, 4(1956) 6) S.J. Jacobs, "The Energy of Detonation", *NavOrdRept* **4366**(1956) 7) Clark & Hawley(1957), 358-59 (Energy); 359-61 (Entropy) 8) Dunkle's Syllabus (1957-1958), 3-4 (Energy relationships); 51 (Definition of "excess enthalpy", the term proposed by Lewis & Von Elbe); 158 (Accdgd to G. von Elbe, the enthalpy per unit mass in front and behind the combustion wave remains constant if combstn is adiabatic, but in the wave itself an "enthalpy excess" exists); 158 (Minimum energy); 198-200 (Transmission of energy); 200 (Any energy transmitted from the deton front to the undetonated expl by conduction or radiation does not change the magnitude of the "enthalpy excess", Q_1); 233-35 (Energies of chemical bonds); 256-58 (Impetus of available energy) 9)Cook(1958), 36 & 265-73 (Available energy or maximum available work potential); 64(Internal energy); 67-8 (Entropy of deton); 326 (Energy of pressure waves); 328 (Energy of underwater shock wave)

10) J.F. Roth, *Explosivstoffe* **1958**, 25-L & 46-L (Enthalpie); 45-L (Gesetz der Erhaltung der Energie); 46-L (Enthalpie und Energie); 52-R (Specifische Energie) 10a) A.N. Dremin & P.F. Pokhil, *DoklAkadN* **127**, 1245-48(1959) & *CA* **54**, 2339(1960) (Width of the chemical reaction zone of the deton waves of TNT) 11) R. Veliky et al, "Enthalpy Change, Heat of Fusion and Specific Heat of Basic Explosives", *FREL PATR* **2504**(1959) 11a) Andreev & Belyaev(1960). 445-66(Energy & work) 12) Dunkle's Syllabus(1960-1961), p 13e (Accdgd to Weinberg the "excess enthalpy" concept can be neither proved nor disproved on theoretical grounds alone) 13) V.N. Zubarev & G.S. Telegin, *DoklAkadN* **147**, 1122-25 (1962) & *CA* **58**, 7779(1963) (Calc'n of the parameters of deton waves of condensed expls) 14a) C.G. Dunkle, "Energy Relationships in the RDX-TNT System", *CGD/M-10* Report, The Johns-HopkinsUniv, Applied Physics Lab, Silver Spring, Md, July 22, 1964 14b) C.G. Dunkle, "Measurements of Detonation Pressure and Temperature in High Explosives", *CGD/M-13* Rept, JHUniv, APL, Silver Spring, Md, June 2, 1965 15) C.G. Dunkle, private communication, January 1968 16) L.P. Orlenko & L.P. Parshev, *ZhPriklMekhan i TekhnFiz* **1965**(5), 130-31 & *CA* **64**, 3274(1966) (The energy, E, in underwater shock waves, generated by spherical chges of Pentolite & PETN, was calcd from a knowledge of the irreversible loss of energy in the shock wave and its mech energy)

Detonation (and Explosion), Energy Relationships in. Under the title "Energy Relationships", C.G. Dunkle treats in the lecture, delivered at Picatinny Arsenal, Dover, NJ on Dec 13, 1955, pp 10-14, the following subjects: a) Heat and energy of reaction of expls b) Heats of detonation and explosion c) Alternate deton rates d) Force, power or impetus of expls e) Brisance and f) Detonation pressure

Detonation (and Explosion), Energy (Relative) Release During Susan Tests for Ignition of Explosives by Impact. Tables 2, 3 & 4, pp 482-84 of paper by L.G. Green & G.D. Do-

rough in 4thONRSympDeton(1965) contain among other data "relative energy release" for expls: LX-04-1 (HMX with 15% Viton A as binder), PBX-9404-03 (HMX with 10% Estane as binder), PBX-9404-03 (HMX with 3% NC & 3% chloroethyl phosphate as binders) and Composition B-3. Viton A is duPont Vinyliden fluoride hexafluoropropylene copolymer

Detonation (and Explosion), Enthalpy in.
See under Detonation (and Explosion), Energy of. See also Cook(1958), 78-9 and the next item

Detonation (or Explosion), Enthalpy Excess in.

In a plane shock wave, the expanding layer just behind the shock front does work on the layer just ahead by compressing it. The energy gained by the latter is called the "Hugoniot energy" and is given by the "Rankine-Hugoniot (R-H) equation". The increase in energy (or enthalpy) is expressed by rises in pressure and temperature

The layer ahead, in turn, passes the energy on by expanding against the layer next beyond. Thus the progress of the wave consists of a passage of energy from one layer to another all the way along. The process of momentum transfer has been likened to a "bucket brigade". If the energy lost is replaced from behind by maintenance of the shock pressure, the wave is supported. If not, the wave has the more usual peaked pressure/time profile; a following rarefaction produces a negative phase, and the shock strength steadily declines because of the energy degradation accompanying the progress of the wave

In a detonation, the "support" comes from the exothermic, gas-evolving chemical reaction touched off by the shock compression. The medium ahead, even before being compressed, may gain energy thru thermal conduction and radiation, and possibly also thru transport of chemical energy by diffusion. While the compression energy is decreased to the extent that energy is gained by other means in advance of the compression, the total energy gained remains the same as the Hugoniot energy. The change of chemical to thermal energy in the detonation reaction

is here viewed as a change from one form of internal energy to another. The change is sometimes viewed, on the other hand, as an outright addition of heat, and expressed by a chemical energy term (Q) added to the Hugoniot energy; the sum is then considered the total gain in heat or thermal energy

The gain is short-lived; each successive layer of the medium, on acquiring the Hugoniot energy, is "in condition to react", but on reaction passes this energy on to the next layer by expanding against it. In the ideal one-dimensional process the explosive on completion of reaction is left with just enough energy to have the detonation products at the isobaric adiabatic explosion temperature. Jacobs showed that "the net energy released by the detonating explosive is the same as released from the chemical process for a constant-volume explosion, as should be expected"

The energy increment that is passed on has been called the *enthalpy excess*, but might better be called the *thermal* or *internal energy excess*, for the products at the isochoric adiabatic explosion temperature have, by definition, exactly the same total internal energy as the original undetonated explosive

In initiation from a point source and subsequent expansion of a "spherical detonation front", the quantity of explosive absorbing the energy at any time exceeds that in a layer of the same original thickness releasing the energy. In effect, the energy per unit mass available for propagating the wave is decreased by convexity of the wave front. The deficiency can be made up, if no energy is added from the outside, only from the detonation products, with a resulting drop in their temperature from the isochoric adiabatic flame temperature. This may quench the chemical reaction. The deficiency diminishes with decrease of wave-front curvature. For "point initiation", enough energy must be added from the outside to make up for the total deficit which accumulates during the time the wave is reaching a diameter at which the curvature drops below a critical value

The same considerations apply to propa-

gation of flame as of detonation, except that there is no shock compression, at least in the beginning. Only thermal and chemical energy are transferred across the flame boundaries, and since the process occurs at virtually constant pressure, the term *enthalpy* is preferable (Ref)

Ref: C.G. Dunkle, private communication, Jan 1968. The above write-up is based principally on Dunkle's "Energy Excess in Detonation and in Flames", given in his "High-Lights of Session 14", The 7th Symp Combstn, dated 12 Nov, 1958)

Addnl Refs: A) C. Lenchitz, "Ice Calorimeter Determination of Enthalpy and Specific Heat of Eleven Organometallic Compounds", PATR 2224 (1955) B) R. Veliky et al, "Enthalpy Change, Heat of Fusion, and Specific Heat of Basic Explosives", PATR 2504 (1959) C) L.M. Fingerson, "Research on the Development and Evaluation of a Two-Sensor Enthalpy Probe", Thermo Systems Inc Rept ARL 64-161 (Oct 1964) [Contract AF 33(657)-9917] D) D.E. Adams, "An Evaporative Film Calorimetric Enthalpy Probe", Cornell Aeronautical Lab Inc Rept ARL 65-47 (March 1965) [Contract AF (33)-657-7774] E) F.A. Vassallo, "Miniature Enthalpy Probes for High Temperature Gas Streams", Cornell Univ Rept ARL 66-0015 (June 1966) [Contract AF 33(615)-2461]

Detonation (and Explosion), Entropy in.
See under Detonation (and Explosion), Energy of and in Cook (1958), 67-8

Section 3

DETONATION (AND EXPLOSION), EQUATIONS OF STATE IN (AND SOME OTHER EQUATIONS)

Introduction

In general, an equation of state of detonation (or explosion) products is an expression of the relationship between pressure, volume and temperature of a heterogeneous system of gases and one or more solids

It can be expressed symbolically as:

$$f(p, V, T) = 0$$

For a perfect (ideal) gas it is simply

$$pV = RT \text{ or } pV = nRT \quad (1)$$

where R is the gas constant and n = number of moles of gas per unit weight of expl (or per unit wt of mixt of deton products), R is 1.9885 calories per °K, per mole of gas, but can be expressed in other units, such as 8.316 joules per °C (Ref 3, p 264). Some equations of state (such as of Jones, Jones-Miller and Wilkins) do not contain R (Ref 17)

Equation (1) is not adequate for real gases when the conditions approach those necessary for their liquefaction. The physical factors which must be responsible for deviation from the "perfect gas equation of state" are the finite size of the molecules, and the mutual attraction (or repulsion) between them. These factors were taken into account in 1873 by J.D. van der Waals (1837-1923) in his "Dissertation", Univ of Leiden (Holland) (Quoted from Ref 3, p 273)

Writing eq (1) as:

$$V = RT / p, \quad (2)$$

it appears that the volume of gas can be reduced indefinitely by greatly increasing p, but this is not true since the molecules have definite volumes which are not vanishingly small. If the minimum volume to which the given mass of gas can be reduced, by increasing pressure, is designated as b, then eq (2) will be changed to:

$$V = b + RT / p \text{ and} \quad (3)$$

$$\text{eq (1) to: } p(V-b) = RT \quad (4)$$

The term b was introduced by van der Waals and named *covolume* (See Vol 3 of Encycl, p C550, under "Covolume"). Actually b does not represent the sum of the volumes occupied by the individual molecules (exclusive of the voids between them) but four times its value. The reason for this is explained in Ref 3, pp 274-75

If eq (4) is written as:

$$p = RT / (V-b), \quad (5)$$

one can draw the conclusion that the pressure exerted by the gas is larger than the value RT/V which would have been produced had the molecules been mere points

The above equations do not take into con-

sideration the attraction forces between molecules which come into play during collision and thus give rise to a certain degree of cohesion among them. If the pressure to be expected when the molecules do not attract each other is P and the observed pressure is p , then the cohesion introduces a difference $P-p=\omega$, sometimes called the *intrinsic pressure* in the gas. On substituting $P=p+\omega$ in equation (4), one obtains:

$$(p+\omega)(V-b) = RT \quad (6)$$

Vander Waals argued that ω is the result of mutual attraction between the bulk of the gas and a sample near the wall of container, and might reasonably be proportional to the densities of both parts - that is to the square of the density of the gas. Since the volume of a given mass varies inversely with the density, the "intrinsic pressure" may be written as $\omega=a/V^2$, where (a) is some constant for that particular gas

This gives the van der Waals equation suitable for any gas as:

$$(p+a/V^2)(V-b) = RT \quad (7)$$

In this eq, the constants b and R are proportional to the mass taken, while a is proportional to the square of the mass. In discussion which follows, the values of the constants a & b will be taken to refer to the same mass as is implied by the other variables, e.g. the use of V & R will imply one-gram molecules of the substance

In rewriting the equation (7) in the form:

$$p = RT/(V-b) - a/V^2 \quad (8)$$

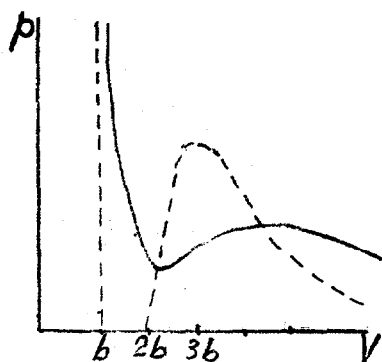

Fig 1. Van der Waals Isothermals
Solid Curve-Derived from Eq 14
Broken Curve-Derived from Eq 11

one observes that pressure p becomes infinite for $V-b=0$; but we always deal with values $V-b>0$. For these values, the curve representing p as a function of V for a given value of T - that is the *isothermal* for that value of T in the (p,V) diagram - lies wholly above all isothermals for lower values of T . To find extrema (maxima and minima) on the isothermals, eq (8) is differentiated with respect to V , keeping T constant:

$$(\partial p/\partial V)_T = 2a/V^3 - RT/(V-b)^2 \quad (9)$$

Eq (9) is equal to 0 at the extrema, whence

$$RT(V-b) = 2a[(V-b)/V]^3 \quad (10)$$

(Ref 3, pp 276-77)

Eliminating T between eq (8) and eq (10), we obtain:

$$p = \frac{2aV-2ab}{V^3} - \frac{aV}{V^3} = \frac{a(V-2b)}{V^3} \quad (11)$$

as the locus of turning-points on all isothermals. This curve is shown as a broken line in Fig 1. It has, itself, a maximum where $V=3b$ as would be seen by differentiating eq (11) with respect to V , and equating to zero. The peak corresponds to a value of $p=a/27b^2$, and the isothermal thru the peak corresponds to $T=8a/27bR$

Points of inflection are characterized by the rate of change of the slope with volume being zero, that is: $\partial/\partial V(\partial p/\partial V)_T = 0$. To find such points, equation (8) is differentiated twice:

$$(\partial^2 p/\partial V^2)_T = (2RT)/(V-b)^3 - 6a/V^4 \quad (12)$$

On setting eq (12) equal to 0, then

$$RTV^4 = 3a(V-b)^3 \quad (13)$$

If V_i = a vol corresponding to an inflection point, then Eq (13) may be written as

$$RTV_i^4 = 3a(V_i-b)^3$$

and on eliminating T between equations (10) & (13), the following relation between the vols corresponding to the extrema V_e and those corresponding to inflection points V_i :

$$\frac{(V_i-b)^3}{V_i^4} = \frac{2(V_e-b)^2}{V_e^3} \quad (13a)$$

To find the critical point D which is both an extremum and an inflection point, set

$$V_e = V_i = V_c \quad (13b)$$

and on substituting Eq (13b) into Eq (13a), one obtains

$$V_c = 3b$$

It has already been mentioned that the *critical point* (qv) of an actual gas is distinguished by the fact that it is a point of inflection with a horizontal tangent; so that the point at $3b$ is identical with the critical point

Thus the *critical constants* (qv) in terms of the constants in vanderWaals equation are:

$$V_c = 3b; p_c = a/27b^2 \text{ and } T_c = 8a/27Rb \quad (14)$$

Isothermals for temperatures above the *critical temperatures* (qv) possess neither inflection points nor extrema, but for $T < T_c$, there is one minimum and one maximum as in the isothermal of Fig 1 (Ref 3, pp 276-78)

The constants a & b in vanderWaals equation can be eliminated by substituting for them expressions derived from the values of the critical constants, given by equations (14). This elimination can be so arranged that the new equation contains only the ratios of the pressure, volume and temperature to their critical values. These ratios are called the *reduced values of the variables* and may be written as:

$$\pi = p/p_c, \phi = V/V_c \text{ and } \theta = T/T_c \quad (15)$$

On combining Equations (7), (14) & (15) one obtains the so-called *reduced equation of van der Waals* (Ref 3, p 280 & Ref 8, pp 597-98):

$$(\pi + 3/\phi^2)(3\phi - 1) = 8\theta \quad (16)$$

This equation contains no explicit reference to either the quantity or the nature of the substance, so that it could be applied in this form to nearly all fluids. It also embodies a very useful concept, the law (or principle) of *corresponding states* (qv) (Ref 3, p 280)

The vanderWaals equation may also be written in the form (Ref 3, p 281):

$$pV = RT - a/V + bp + ab/V^2 \quad (17)$$

where all the terms on the right-hand side, except the 1st, are small, provided the p 's are not extremely high and V 's are not very small

Another form of the equation is:

$$pV = RT + (b - a/RT)p + (ab/R^2T^2)p^2 \quad (18)$$

In conclusion, it may be said that van der Waals equations can only provide reasonably accurate representation over limited ranges of variation of the pressure and temperature. For this reason many attempts were made to produce a more satisfactory equation by modifying vanderWaals equations. Such modifications were made by Berthelot (See item b₅), Callendar (See item c₂), Clausius (See item c₃), Dieterici (See item d₂), Hirschfelder et al (See item h₃), Keyes (See item k₁), Lees (See item l₃), and Macleod (See item m₁)

Accdg to Dunkle (Ref 17), for high temps and moderate pressures which give rise to large values of V so that $P \gg a/V^2$, vander Waals' equation reduces to Abel's equation (See item a₁)

Equations of State Applicable to Detonation Products of Condensed Explosives. In order to calculate the motion of the systems in which a condensed explosive is a component, it is necessary to know the equation of state relating the pressure, temperature and volume of the products of the detonation. In the case of CHNO expls, these products are mixtures of H₂O, CO₂, CO, H₂, NH₃, NO₂, etc, whose exact composition changes with pressure and temperature on the path of motion of the system. If it is assumed that all reaction rates are infinite compared with time of observation of the system so that the products are in a state of equilibrium or quasiequilibrium, then it may be logical to develop an equation of state without considering time-dependent effects. In the region of the *Chapman-Jouguet (C-J) point* (qv), temperatures are of the order of 3000°C, and assumption of equilibrium is reasonable even for changes occurring in times of a microsecond. At expansion to 1 kilobar, however, the temperatures are only several hundred degrees and equilibrium is not reached. For many systems, the region of interest in the P-V plane is restricted to points near the C-J point on the isentrope thru the C-J point. For example, when a plane detonation wave is used to push a metal plate in contact with the condensed explosive, the plate receives most of the energy from the initial

push and its velocity is sensitive to the exact equation of state for large expansions. At the same time a detonation wave striking the metal does not transmit a shock into the explosive gases strong enough to show the difference between the Hugoniot (qv) and isentrope. For such a system it is sufficient to use the equation of state: $p = (\gamma - 1) e / v$, where p = pressure, e = internal energy, v = specific volume and $\gamma = -(d \log p) / (d \log v)$. This equation, however, is inadequate for many systems, but there are some equations of state which give fairly accurate results. As an example of such equations may be cited that of Wilkins (See item w_1 of this Section)

In the list of equations of state and of some other equations used in detonation calculations, which follows, the symbols listed by Cook (Ref 12, pp 376-78) will be used, with a few exceptions. Small v will be used for specific volume (cc per gram of expl) and small e for specific energy, although some investigators use caps. For pressure which does not include "intrinsic" pressure, ω , small p will be used, while P will be used for total pressure $p + \omega$ (See eq 6) and not for p/p_2 listed by Cook. Some of the symbols used in equations of state are not listed by Cook

List of Equations

a_1) *Abel Equation of State*. Taylor (Ref 7, pp 87 & 90) gave for the detonation in condensed explosives yielding only gaseous products the following equation:

$$p(v-a) = nRT$$

where: p = pressure, v = specific volume, a = covolume of gaseous mixt in cc/g (which may be regarded to a first approximation as constant, provided it is small compared with v); n = gaseous moles per gram of total products, T = absolute temperature and R = gas constant

For condensed explosives whose products of detonation contain a condensed phase, Taylor (Ref 7, p 114) gives:

$$p_1(v_1 - \beta) = n_1 RT_1 \text{ and } \beta \equiv ma + (1-m)\phi_1$$

where p_1 = pressure of gaseous phase; v_1 = specific volume of gaseous phase; n_1 = number of gaseous moles per gram of total products; m = proportion by weight of gas in the products; a = gaseous covolume per gram of gas and ϕ_1 = specific volume of the condensed phase [See also Ref 11, pp 50-2 & Ref 12, p 268 (the equation mentioned only)] (Compare with Noble-Abel Equation listed here as item n)

Landau & Stanyukovich (Ref 1f) proposed a modification of Abel equation of state, which is suitable for calculation of detonation properties of condensed explosives. Their equation of state is described here under items l_1 & l_2

Travers (Ref 3a) applied Abel equation to detonation of gases

a_2) *Allan & Lambourn Equation of State*. A detailed discussion is given by J.W.S. Allan & B.D. Lambourn in the paper: "An Equation of State of Detonation Products at Pressures Below 30 kilobars" (Ref 15, pp 52-66). A brief description is given here under "Wilkins Equation of State" (item w_1)

A & L consider their equation as a modification of Wilkins equation, but it also incorporates the data of Fickett-Wood (Ref 15, p 53) and Pike (Ref 15, pp 53-4) equations of state

b_1) *Beattie-Bridgeman Equation of State*. It is, accdg to Hirschfelder et al (Ref 8e, p 253), one of the best empirical representations of p - V - T data for gases up to pressures of the order of 250 atm

$$pV = RT(1 - c/VT^3)(V + B_0 + bB_0/V) - A_0(1 - a/V)$$

The five adjustable constants A_0 , B_0 , a , b and c , have been detd for a large number of gases and are given in Table 4.2-2 on p 254 of Ref 8e

The equation fails badly at very high pressures, but for very low pressures the eq can be expanded into the virial form as explained in Ref 8e

The BB equation is also listed in Ref 8, p 69 but in a different form. It was claimed that it applies a correction for reduction of

the effective number of molecules by molecular aggregation due to various causes:

$$p = [RT(1-\epsilon) / V^2] (V+B) - A/V^2$$

where A, B and ϵ are constants defined in terms of five other empirical constants A_0 , B_0 , a & b by the following relationships:

$$A = A_0(1-a/V); B = B_0(1-b/V) \text{ and } \epsilon = c/VT^3$$

Values of A_0 , B_0 , a, b & c can be detd from tables, such as Table 4.2-2 given in Ref 8e, p 254

J.A. Beattie & O.C. Bridgeman equation of state was first described in ProcAmAcadSci 63, 229(1928), which we did not consult

One of the modifications of Beattie & Bridgeman equation is given under "Su & Chang Equations of State" (See item s_2)

b_2) *Becker Equation of State (Semiempirical)*.

Its historical background is given under the next item, b_3 . A slightly different than the Addnl Ref N version of this equation is given in Ref 1d and Ref 1g, p 85, where it was stated that the modified version of Becker equation of state, which is suitable for use in calculation of gaseous explosions, can be written as:

$$pvM = nRT(1+xe^x) \text{ with } x = k/T^{1/3}Mv \quad (1)$$

Here p is pressure; v = specific volume; R = gas constant for M grams of gas; n = number of moles of gas per unit weight; T = temperature and e = the base of natural logarithm = 2.718

The expression $k/T^{1/3}$, in which k is the covolume constant, is equivalent to vander Waals' covolume in the limit of low densities. The compn of the expln products was approximated by the rule that in listing the products oxygen was considered to react first with carbon to form CO, addnl oxygen reacted with hydrogen to form water, and the remaining oxygen, if any, reacted with CO to form CO_2

The more general equation of state:

$$pvM = nRT(1+xe^{\beta x}), \text{ in which } x = k/T^{1/4}Mv \quad (2)$$

could be applied to deton of condensed expls. Here the coefficient β was included in the exponential term to secure constancy of the k with respect to density of gases, and in which $T^{1/4}$ dependence of the covolume

upon temperature was adopted. By trial, the value 0.3 was obtd for the parameter β and the compn of expln products was approximated as mentioned above. A computational procedure was devised in which "ideal" values of deton vel & temp were calcd on the assumption that the product gases obeyed the ideal gas law. The correction factors resulting from the introduction of the equation of state (2) for the real gases could then be tabulated as functions of the heat capacity of the product gases, considered ideal and from the argument:

$$x_1 = (\rho_1 k) / T_2^{1/4} M \quad (3)$$

where ρ_1 is the density of the intact explosive and T_2 the temperature of detonation front (Ref 1g, p 85)

(Compare with next item, b_3)

b_3) *Becker-Kistiakowsky-Wilson Semiempirical Equation of State*. Although commonly called the Kistiakowsky-Wilson equation of state, it was attributed to Becker by K & W (Ref 1d)

Becker (Ref 1a) proposed in 1921 the equation:

$$pv/RT = (1+xe^x) - \frac{a}{v} + \frac{b}{v^{n+1}}, \text{ where } x = k/v$$

as an equation of state for nitrogen at high densities. It was based on a "virial equation of state" and used a repulsive or "point centers of repulsion" potential to estimate the 1st term xe^x . The 2nd term, a/v , described the attractive forces and the 3rd term was used to obtain agreement at the *critical point* (qv)

In 1922, Becker (Ref 1a) proposed another equation

$$pv/RT = 1 + xe^x$$

to compute the deton velocities of NG and MF

Kistiakowsky & Wilson (Ref 1d) used for x the expression $k/vT^{1/3}$ and found that k, the covolume constant, could be approximated as an additive function of the covolumes of the constituent molecules of the product gases for a large number of expls. R.S. Halford was an active contributor to this equation of state study

Kistiakowsky & Wilson attribute to D.P. MacDougall & L. Epstein the addn of β to the repulsive term, which gives:

$$pv/RT = 1 + xe^{\beta x} \quad \text{with } x = k/vT^{\alpha}$$

where $\alpha = 0.25$ and $\beta = 0.3$

Cowan & Fickett (Addnl Ref E) added the θ to T to prevent pressure from tending to infinity as the temperature tends to zero and to keep $(\partial p/\partial T)_v$ positive over the range of volumes of interest. They found that the values $\alpha = 0.5$ and $\beta = 0.09$ were satisfactory for reproducing experimental detonation velocity-density curve and C-J pressure of Comp B. The value of θ they used was 400; k was defined as $\kappa \sum x_i k_i$, where κ was 11.85, x_i was the mole fraction and k_i were the individual geometrical covolumes. The final version of Cowan-Fickett equation is given here under Kistiakowsky-Wilson Equation of State

With this historical background given by Mader (Addnl Ref N, pp 7-8), it becomes apparent that the BKW equation of state is based upon a repulsive potential applied to the virial equation of state:

$$pv/RT = 1 + B/v + C/v^2$$

Replacing B/v with x and neglecting higher order terms, there was obtained:

$$pv/RT = 1 + x + xe^{\beta x}$$

or to a first approximation:

$$pv/RT = 1 + xe^{\beta x}$$

Using a repulsive potential of the form $U = A/r^n$, where r is the separation distance, Jeans (as quoted by Mader in Addnl Ref N, p 8) showed that:

$B = k/T^{3/n} = k/T^{\alpha}$, if $\alpha = 3/n$ and $k \propto A^{3/n}$
 x was given above as equal to k/vT^{α}

The above description was taken from the report of Mader (Addnl Ref N, pp 7-8)

In a parameter study of the BKW equation of state one may adjust parameters alpha, beta and kappa, as well as the covolumes of the deton products

Cowan & Fickett (Addnl Ref E) who performed BKW equation parameter study, showed that, for a given alpha and beta, one may adjust kappa to give the exptl vel for

a single expl at a single density. The slope of the detonation velocity-density curve can be altered by changing beta. With successive iterations on kappa and beta, Mader (Addnl Ref N, p 8) reproduced the experimental deton vels at two densities for a single explosive

The semiempirical BKW equation of state has been used successfully by Mader (Addnl Ref K₃) for predicting properties of condensed expls and for understanding the observed deton properties; also as an equation of state for hydrodynamic calculations (Addnl Ref M₂). The studies of Fickett (Ref M₁) with LJD (Lennard-Jones-Devonshire) equation of state suggested that it may not be possible to improve markedly the agreement, already obtd using the BKW equation, between the computed and experimental deton properties by modifying the form of the equation of state. The idealizing assumptions of chem and thermodynamic equilibrium, for example, may prevent one from obtg complete agreement for all expls with any equation of state (Addnl Ref N, p 5)

Mader (Addnl Ref N) determined C-J parameters for many C-H-N-O expls using for calculations the IBM-7030 STRETCH Computer, and the Code STRETCH BKW which was described in Los Alamos Scientific Laboratory Report: "STRETCH BKW - A Code for Computing the Detonation Properties of Explosives"

In order to obtain better agreements with the experimental Hugoniot, the covolumes of water and carbon dioxide were changed to 250 and 600, respectively; the covolume of CO was 390 and of N₂ 380. These parameters, as well as $\theta = 400$, can be used for all expls, but it is not possible to obtain a single set of the BKW equation of state parameters which would fit all types of expls. The parameters: $\alpha = 0.50$, $\beta = 0.09585$ and $\kappa = 12.685$ were found to be satisfactory for high density expls whose detonation products contain large amounts of solid carbon (such as TNT); parameters: $\alpha = 0.50$, $\beta = 0.16$ & $\kappa = 10.91$ were satisfactory for most other expls, including RDX; parameters: $\alpha = 0.54$, $\beta = 0.181$ & $\kappa = 14.15$ also fit RDX (Addnl Ref N, pp 3 & 13)

The computed C-J detonation properties: D (detonation velocities in cm/ μ sec), p (pressure in megabars), T (temperature, $^{\circ}$ K), and γ (polytropic exponent) are given in Table III, pp 14-17 of Addnl Ref N. The C-J volume in cc/g of expl and some other properties were also determined, but they are not shown in Table III; they are listed on pp 26-324 (Compare with items b_2 , h_1 , h_2 , k_3 & k_4)

b_4) *Benedict-Webb-Rubin Equation of State.* It may be considered as an extension of Beattie-Bridgeman equation for pure substances and mixtures. As the BWR equation is very long and complicated it is not described here. The reader is referred to the book of Hirschfelder et al (Ref 8e), where a full description is given on pp 258-60, which includes Table 4.2-4 for empirical constants of BWR equation of state

b_5) *Berthelot Equation of State.* It is one of the earlier two-constant, van der Waals type empirical equations of state, which can be used for dense gases. It is given in Ref 8e, pp 250-52

$$(p + a/TV^2)(V - b) = RT \quad (1)$$

where p=pressure, V=volume, a=measure of cohesion between the molecules and b=value proportional to the volume of the molecules

For making slight correction for non-ideality in dilute gases, Berthelot changed the equation to:

$$pV = RT \left(1 + \frac{9pT_c}{128p_c T} \right) \left[1 - 6 \frac{T_c^2}{T^2} \right] \quad (2)$$

in which p=pressure of gas; V=volume of gas; R=gas constant; T=absolute temperature; p_c =critical pressure and T_c =critical temperature. In Table 4.2-1, p 252 of Ref 8e are summarized the virial coefficients and critical constants for Berthelot equation of state

Equation (2) is given in Ref 8, p 161, where it is stated that Berthelot equation is derived from Clausius equation (See item c_2)

b_6) *Boltzmann Equation of State.* A "virial equation" (qv), which is applicable to condensed expls yielding only gaseous products, as given by Taylor (Ref 7, p 97) is:

$$pV = nRT(1 + b_0/V + 0.625b_0^2/V^2 + 0.2869b_0^3/V^3),$$

where p=pressure; V=volume and b_0 =second virial coefficient independent of temperature.

This equation, modified by Hirschfelder & Roseveare, was found to be suitable for moderately high pressures. It is given in Ref 8e, p 262 in the following form:

$$pV/RT = 1 + B(T)/V + 0.625b_0^2/V^2 + 0.2869b_0^3/V^3 + 0.1928b_0^4/V^4$$

where B(T) is the 2nd "virial coefficient" and b_0 =the usual van der Waals constant (See also Ref 1c)

b_7) *Brinkley-Wilson Equation of State.* Accdg to Cook (Ref 12, p 33-L), this equation was described in Bulletin 84, "Report of the Committee on Hydrodynamics", National Research Council, p 551, 1931 (This bulletin was not seen by us)

c_1) *Caldirola & Paterson Equation of State.* Dunkle (Ref 10, p 183), stated that Cook (Ref 2c) found by working backward from experimental detonation rates to corresponding values of covolume, that for all expls at very high pressures the covolume is a function of the specific volume only. At these pressures all molecules have the same covolume per unit weight; the dependence of $\alpha(T, v)$ on temperature is exceedingly small. The equation of state can be written

$$pV = nRT + \alpha(v)p$$

similar to those used by Caldirola and Paterson, and it is possible to draw the same curve of covolume vs specific volume (Compare with "Covolume Equation of State")

c_2) *Callendar Equation of State.* It is one of the modifications of van der Waals equations, originally developed to represent the behavior of steam at moderate pressure. It was found to be applicable to other vapors and to gases:

$$p(V-b+c) = RT,$$

where b = covolume and c , representing attractive forces, is to be taken as inversely proportional to the n^{th} power of T . For steam $n=10/3$ (Ref 3, p 283)

c_3) *Clausius Equation of State*. It is a modification of vander Waals equation, in which is introduced an expression $1/T(V+c)^2$ to correct the pressure-correction term (a) for its variation with temperature. Clausius equation is given in Ref 8, p 161 in the form:

$$\left[p + \frac{a}{T(V+c)^2} \right] (V-b) = RT,$$

in which a and b are vander Waals constants and c is a constant which is a function of a , b and R

Clausius equation is also described in Ref 3, p 282 (Compare with vander Waals equation described in the "Introduction" to the section on Equations of State

c_4) *Constant- β and Constant- γ Equations of State*. Fickett & Wood (Addnl Ref H, pp 528-34) derived two empirical equations of state for detonation products of condensed explosives. Since processes such as heat conduction and thermal diffusion are ordinarily neglected in such work, it is usually sufficient to state the equation of state in the form $e = e(p, v)$, where e , p and v are the specific energy, pressure and specific volume, respectively

As we were not sure which of the numerous eqs listed in paper of Fickett & Wood is β and which is γ , we asked Mr. Fickett for clarification. We received a letter (Ref 18) which answered our questions. The letter is reproduced here after changing (by permission of Mr F) E , P , V to e , p , v , since they represent specific values

"By an equation of state we mean a relation of the form

$$e = e(p, v).$$

We specialize immediately to the particular form (equation numbers will be the same as those of the paper) (Our Addnl Ref H, pp 530-33)

$$e = e_i(v) + \beta_i(v) [p - p_i(v)] v, \quad (3.6)$$

where the subscript i denotes quantities evaluated on a reference curve and the function β is defined as

$$\beta \equiv (\partial e / \partial p v)_v, \quad (3.8)$$

and is here assumed to be a function of v only. The reference curve is taken to be the isentrope through the C-J state at a particular initial density

The form which we have called the "constant- β equation of state" is obtained from (3.6) by making the additional assumption

$$\beta_i(v) = \beta_1 = \text{constant} \quad (4.1)$$

The constant- β equation of state is then

$$e = e_i(v) + \beta_1 [p - p_i(v)] v,$$

in which the form of the reference curve remains to be specified

For the constant- β equation of state we find that the function $\gamma(p, v)$ defined as

$$\gamma = -(\partial \ln p / \partial \ln v)_S \quad (S = \text{entropy}), \quad (3.3)$$

which is often of interest, is given by

$$\gamma(p, v) = \kappa + [\gamma_i(v) - \kappa] [v_i(v)/p]; \quad \kappa = 1 + \beta_1^{-1}, \quad (4.2)$$

where $\gamma_i(v)$ is the value of γ on the reference curve. The reference curve is often taken to be the simple γ -law form

$$p = p_1 (v/v_1)^{-\gamma_1} \quad (2.3)$$

with p_1 , v_1 , γ_1 constant

The constant- γ equation of state is obtained from (3.6) by making a different assumption about the form of $\beta_i(v)$, viz

$$\beta_i(v) = [1 + C(v/v_1)^{\gamma_1 - 1}] / (\gamma_1 - 1), \quad (4.6)$$

in which γ_1 and C are constant, together with the γ -law form for the reference curve

$$p_i(v) = p_1 (v/v_1)^{-\gamma_1} \quad (4.3)$$

The result can be written in the form

$$e = \frac{pv}{\gamma_1 - 1} + Cv^{1-\gamma_1} pv^{\gamma_1} + \text{constant}$$

For the constant- γ equation of state we find that the function γ is

$$\gamma(p, v) = \gamma_1 = \text{constant},$$

hence the name"

(See also Addnl Ref M₁, pp 153-54 & 161)

c₅) *Cook Equation of State*. See under Kistiakowsky-Halford-Wilson-Brinkley Equation of State and in Ref 12, p 63

c₆) *Corner Equation of State*. See Vol 3 of this Encycl, p C542-L. Its modification by Murgai is on p C542-R

c₇) *Cottrell-Paterson Equation of State*. It was briefly described in Vol 3 of Encycl, p C547-R giving three refs, but no formula. Cook (Ref 12, p 66) gives:

$$pv = 3nRT + 2Xv^{-2},$$

where X is an adjustable parameter. He states that the formula, when applied to PETN, gave only order of magnitude agreement of calculated and observed velocities (See also Ref 7a)

Its application to oxygen-deficient expls, such as TNT, is described by Murgai (Ref 8a)

c₈) *Covolume Equations of State*. Any equation of state which uses "covolume" as one of its terms may be so-called. Cook (Ref 12, pp 63-4) adopted the "covolume approximation"

$$a(T_2v) = a(v),$$

where T₂ is temperature of detonation and (a) the covolume such as given in Abel's equation of state or as covolume b of van der Waals equation

Equations of Jones, of Halford-Kistiakowsky-Wilson-Brinkley and of Noble-Abel are also covolume equations of state

c₉) *Cowan-Fickett Modification of KW Equation of State*. See Kistiakowsky-Wilson Equation of State and Addnl Ref E, p 932

d₁) *Deal Polytropic Equation of State*. Using the equation $P/\rho^\gamma = \text{const}$ for the isentrope with $\gamma=2.77$, W.E. Deal conducted "Measurement of the Reflected Shock Hugoniot and Isentrope for Explosive Reaction Products", as described in the Physics of Fluids, 1, 523-27 (1958). With the same equation, but different γ values, Deal deter-

mined "Low Pressure Points on the Isentropes of Several High Explosives", and described them in the 3rdONRSympDeton, pp 386-95 (1960). Expls examined by Deal included pressed TNT, Grade A Comp B, 77/23-Cyclotol and Octol contg ca 77.6% HMX. The values for γ ranged betw 2.704 and 2.844, as shown in Table II, p 394. Same Table shows values for C-J pressure; in Table I, p 391 are given some other values

d₂) *Dieterici Equation of State*. Accdg to Joffe (Ref 2b), one of the early attempts (1899) to improve on the vanderWaals' equation of state (1873) is the equation:

$$p = \frac{RT}{v-b} \cdot e^{-a/vRT} \quad (1)$$

proposed by C. Dieterici on semi-empirical grounds. Here p=pressure; v=specific volume; T=absolute temperature; R= gas constant; a=measure of cohesion betw molecules; b=value proportional to the volume of the molecules and e=base of natural logarithm

The equation has been studied by several investigators and has been found to possess certain advantages over the vander Waals equation

A modified form of eq (1):

$$p = \frac{RT}{v-b} \cdot e^{-aT_c^{1/2}/vRT^{3/2}} \quad (2)$$

was proposed by Dieterici in 1901 and in this form it has achieved a greater success than eq (1)

A further modification was proposed by Joffe in 1927 and claimed to be more satisfactory than eqs (1) or (2). It is described here as eq (3)

Original Dieterici equation is also described in Ref 3, p 282; Ref 8e, p 250 and Ref 13, p 15d.

Erpenbeck & Miller (Addnl Ref I) stated that the Dieterici equation better represents the fluid properties near the liquid region and it gives a value $RT_c/p_c v_c = 3.69$, nearly the average for all common gases. Subscript c means critical. Same value is given by Joffe (Ref 2b, p 1216) for eqs (1)

& (2), vs 3.67 obtd with vander Waals equation

The critical constants of Dieterici eq were summarized in Table 4.2-1, p 252 of Ref 8e

The modification of Dieterici equation proposed by Joffe (Ref 2b, p 1216):

$$p = \frac{RT}{v-b} - \frac{R\sqrt{TT_c}}{v-b} (1 - e^{-a/vRT}) \quad (3)$$

was claimed to be more satisfactory at higher pressures. Eq (3) reduces to eq (2) at low pressures, and at critical temperature both (3) & (2) reduce to (1)

The values of constants a & b of eq (3), as well of eqs (1) and (2) can be obtd from relationships:

$$a = 4R^2 T_c^2 / p_c e^2; \quad b = RT_c / p_c e^2,$$

where subscript c means critical

It appears from the study by Joffe & others that in case of gases which, like nitrogen obey the law of *corresponding states* (qv) fairly well, the eq (3) has advantage over original Dieterici equation. Although eq (3) does not possess the accuracy of eqs with several adjustable constants, such as the Beattie-Bridgeman eq, it retains the theoretical advantage of Dieterici eq, since it has only two constants in addn to the gas constant, and since these constants can be eliminated in terms of the critical constants, giving a reduced equation of state (Ref 2b, p 1217)

e) *Eyring Equation of State*, which is suitable for dense gases, is given in Ref 8e, p 282 as:

$$[p + a(T)/V^2](V - 0.7816b^{1/3} V^{2/3}) = RT$$

It may be considered as the limiting form of vander Waals equation when the latter is corrected for the overlapping of the hard spheres. The necessity of doing this was recognized by vander Waals and Boltzmann who wrote the equation as an infinite series in this form:

$$[p + (a/V^2)] = (RT/V) [1 + b/V + 0.625(b^3/V^2) + 0.2869(b^3/V_c^3) + \dots]$$

This equation is similar to the Boltzmann equation described here as item b₆,

except that it has the term a/V^2 added (Ref 8e, p 282)

f₁) *Fickett Equation of State Based on Intermolecular Potentials* is described in Addnl Ref M, pp 19-44 & 115-23. Its comparison with other equations of state is given here under "Intermolecular Potentials, Equations of State Based on" and on pp 153-55 of Addnl Ref M

f₂) *Fickett-Wood Equations of State*. See "Constant- β and Constant- γ Equations of State"

f₂ bis) *Fickett-Wood-Salsburg Discussion on Equations of State Based on Intermolecular Potentials*. See under item i and in Ref 9a

f₃) *Furth Equation of State*. Accdg to Dunkle (Ref 10, p 183), it is one of the three equations of state used, at the time of compiling his Syllabus (1957-1958), for solid expls. Other two equations are those of *Murnaghan* and *Pack-Evans-James*. These three equations are described by Duvall & Zwolinski (Ref 9b)

g₁) *Gamma-Law Equation of State*. See under "Polytropic Equations of State"

g₂) *General Equation of State*. Accdg to Cook (Ref 12, p 61), such an equation can be represented as:

$$pv = nRT + a(T, v)p$$

where a is covolume; p = pressure of detonation; v = specific volume of gases evolved; n = total number of moles of gaseous products; and T = absolute temperature of detonation

The so-called *virial equation of state* (See item v₂):

$$pv = nRT(1 + B/v + C/v^2 + D/v^3 + \dots)$$

is also known as the "general equation of state"

g₃) *Generalized Equation of State for Gases and Liquids of Hirschfelder et al* is described in the same refs as listed under Hirschfelder

et al Generalized Equation of State for Gases and Liquids

g₄) *Generalized Equation of State of Su and Chang*. See under "Su and Chang Equations of State"

g₅) *Grüneisen Equation of State*. In the book of Taylor (Ref 7, p 96), it is stated that H. Jones developed in 1941 a "state equation of the Grüneisen type", based on the Einstein model of the form

$$p = Ae^{-av} - B + fRT$$

where a, A, B & f are constants which are identified by reference to Bridgeman's 68°C isotherm for nitrogen and the latent heat of nitrogen at its boiling point (See also item m₂ - "Mie-Grüneisen Equation of State")

h₁) *Halford-Kistiakowsky-Wilson (HKW) Equation of State* can be written similarly to eq (4.3-3) given in Ref 8e:

$$pV/RT = 1 + KT^{-1/4} e^{(0.3K/T)^{1/4}}$$

where K is constant equal to $\sum n_i k_i$; p = pressure, V = volume; n_i is the number of moles of gas in the ith component per cc of mixture and k_i are empirical constants characteristic of each of the chemical species

In Dunkle's Syllabus (Ref 10, p 181), K is given as ≈ 12.5 and it is stated that HKW equation implies that the fugacities of all chemical species are increased in the same ratios at high densities (Compare with items b₂ & b₃)

h₂) *Halford-Kistiakowsky-Wilson-Brinkley (HKWB) Equation of State*. See Kistiakowsky-Halford-Wilson-Brinkley (KHWB) Equation of State

h₃) *Hirschfelder et al Equation of State of the Propellant Gases* is described in Addnl Ref A₃

h₄) *Hirschfelder et al Generalized Equation of State for Gases and Liquids*. They noted that since in the van der Waals equation the

term (b) corresponds to the volume "excluded" because of the finite size of molecules, the following generalization can be obtd:

$$(p + a/V^2)(V - b + b^1/V) = RT$$

in which a, b, and b¹ can be determined from the *critical constants* (qv) and the vapor pressure (Ref 10, p 194)

Other forms of Hirschfelder equation are given in Ref 9d and Addnl Ref G

h₅) *Hirschfelder & Roseveare Modification of Boltzmann Equation of State* is given under Boltzmann Equation of State. A slightly different version:

$$pV/nRT = 1 + b/V + 0.625b_0^2/V^2 + 0.2869b_0^3/V^3 + 0.1928b_0^4/V^4$$

is given in Ref 7, p 34

h₆) *Hirschfelder-Stevenson-Eyring Equation of State*, developed in 1937 is given in Ref 7, p 35:

$$pV/nRT = 1/[1 - K(b_0/V)^{1/3}]$$

where K is a constant varying from 0.6962 to 0.7163, depending on the manner of packing of the product molecules; other symbols have their usual significance

h₇) *Hugoniot and Rankine-Hugoniot Equations*. They are described together since they are closely related

The change of state across the shock front is given by the adiabatic "Rankine-Hugoniot (R-H) Equation":

$$e_2 - e_1 = \frac{1}{2}(p_1 + p_2)(v_1 - v_2), \quad (1)$$

whereas the change of state across the combustion front is given by "Hugoniot Equation":

$$e_3 - e_2 - Q = \frac{1}{2}(p_2 + p_3)(v_2 - v_3) \quad (2)$$

In these equations e denotes the unit of internal energy, p = pressure, v = specific volume and Q = chemical energy released per unit mass of substance. Subscripts 1 and 2 of eq (1) denote conditions ahead and behind shock front, whereas subscripts 2 & 3 of eq (2) denote conditions ahead and behind the combustion front. The internal energy, e, being a state function, can be expressed in terms of pressure, p, and speci-

fic volume v , by the use of an appropriate equation of state, $e=e(p,v)$; and, consequently, equations (1) & (2) can be regarded as representing relationship between p and v with Q as a parameter (Ref 8b, p 472) (See also Ref 12, pp 61-2)

More detailed discussion on H and R-H equations is given in Ref 7, pp 66-7, 69-81, 87, 92 & 99; Ref 10, pp 44-5, 54, 100, 127 & 165-66

There are several other formulations of H & R-H equations than given above. For example, Taylor (Ref 7) lists equations (VI.45), p 80, (VII.4), p 86 and (VII.36), p 99 as versions of R-H equation

It must be noted that R-H equations, being derived from the conservation equations, are valid regardless of the equation of state of the medium. Nevertheless, they cannot be solved explicitly, nor even plotted without specifying a suitable equation of state. This can be done as explained in Ref 4, p 951; Ref 7, pp 66-72; and Ref 10, pp 45, 127 & 165-66

Rankine-Hugoniot equation is also discussed under "Detonation, Theories of"

In Dunkle's Syllabus (Ref 10, p 45) is listed an equation proposed by J.G. Coffin:

$$h_2 - h_1 = \frac{1}{2}(q_1^2 - q_2^2) = \frac{1}{2}(v_1^2 - v_2^2)[p_2 - p_1] / (v_1 - v_2) = \frac{1}{2}(v_1 + v_2)(p_2 - p_1)$$

It is designed to serve as a "complement of the Rankine-Hugoniot equation"

In the paper entitled "Hugoniot Equations of State of Several Unreacted Explosives", Coleburn & Liddiard, Jr (Ref 15a) stated that any quantitative measurements of shock parameters, used to determine hazards from burning or detonation, require knowing the shock Hugoniot of the unreacted explosive or propellant. Although the dynamic pressure-volume relations, or Rankine-Hugoniot curves, have been measured after WWII by several investigators, only few data were known for expls and propnlts. This lack of knowledge induced Coleburn & Liddiard, Jr to determine plane shock compressions to obtain the unreacted equations of state of eleven important propellants and high expls for

pressures up to 90 kbar. They also detd longitudinal sound-wave velocities by measuring the transit times of weak shock waves (~ 100 kbar)

Dynamic pressure-volume data were derived from shock-wave experiments relating the measured velocities of the shock wave, U_s , and the material behind the shock front, u_p , to the pressure p and specific volume v of the compressed material. The relationships are given by the Rankine-Hugoniot Equations:

$$v/v_0 = (U_s - u_p) / U_s \quad (1)$$

$$\text{and } p = (1/v_0) U_s u_p \quad (2)$$

Description of exptl procedures is given on pp 1930-34 of Ref 15a. A schematic arrangement for delivery of plane shock wave and for measuring shock-wave velocities for shock strengths from 10 to 90 kbar in the specimens and the free-surface velocity of the specimen plate is shown in Fig 2, p 1930.

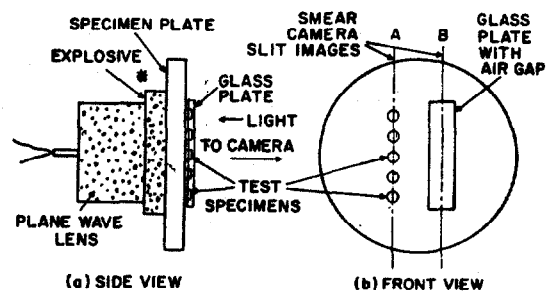

FIG 2. Arrangement for delivery of plane shock wave and for measuring shock-wave velocities in the specimens and the free-surface velocity of the specimen plate

* A layer of silicone grease about 0.003 mm thick filled the gap between the specimen and the highly polished specimen plate. The specimen was held in place by a small amount of Eastman 910 adhesive placed around the periphery of the specimen

In this arrangement the shock wave produced by the detonating explosive system arrives at the free surface of a 2.5-cm thick specimen plate (brass or Plexiglas). The arrival is plane parallel to within $\pm 0.01 \mu\text{sec}$ across an 8- to 10-cm diameter. The specimens of expls are placed within this plane region. The shock-wave arrivals at the free-surface of the specimen plate and at the specimens of expls were recorded by a smear camera

using a reflected light technique. In this method the light was reflected continuously from the free surface into the camera. The shock-wave arrival at any point along the surface produced a sudden change in light reflected from that point. The light was provided by two exploding-wire light sources. To increase the reflectivity, an aluminized side of Mylar film was attached to the surface of specimen by a very thin layer of silicone grease. A dual-slit system was used in the camera

The various shock-producing systems were calibrated by using free-surface velocity measurements of specimen plates and corresponding shock-wave velocities obtained from the known equations of state of the specimen plate materials. According to Footnote 4 on p 1931 of Ref 15a, "the free-surface velocity for a plane shock wave is almost twice the particle velocity"

By using the method described on p 1931, Coleburn and Liddiard, Jr obtained particle velocities, u_p , and pressures for typical shock-producing systems. Their data are given in Table II, p 1931, using brass and Plexiglas as specimen-plates of various thicknesses

They also derived formulas for U_s-u_p relationships for brass and Plexiglas. These relationships are given as eqs (3) & (4)

Measurements of the transit times of weak shock waves (~ 100 bar) were used to obtain sound wave velocities in larger specimens than listed in Table II. In the arrangement of Fig 3 a cylinder (or slab) of the expl was immersed in a Plexiglas container filled with water. Initiation of the detonator produced a shock wave which arrived nearly plane thru the water at the surface of the expl specimen. The motion of wave was recorded by a smear camera using a shadowgraph technique. Plots of U_s-u_p relationships showed that the resulting curves were nearly straight lines and that for particle velocities, u_p , from 0.3 to 1.2 mm/ μ sec, shock wave velocities are:

$$U_s = A + Bu_p, \quad (5)$$

where A & B are the intercept and slope, respectively, of the U_s-u_p curves. These values are constants for each explosive and are given in Table III of Ref 15a, p 1933. These constants are also used in the experimental Hugoniot obtained from eqs (1), (2) and (5)

$$p = A^2(v_0 - v) / [(v_0 - v)(v_0 - v)]^2 \quad (6)$$

In the following table are given the data for expls selected from the tables given by Coleburn & Liddiard, Jr (Ref 15a)

Table

| Explosive | Density g/cc | A ⁽¹⁾ [(cm/sec) x 10 ⁶] | B ⁽²⁾ [(cm/sec) x 10 ⁶] | P ⁽⁵⁾ (k bar) | C ⁽³⁾ [(cm/sec) x 10 ⁶] | D ⁽⁴⁾ (mm/ μ sec) | p(spike) ⁽¹⁴⁾ (k bar) |
|-------------------------|-----------------|---|---|-----------------------------|---|-------------------------------------|-------------------------------------|
| TNT ⁽⁶⁾ | 1.614 | 2.390 | 2.050 | 189 | 2.572 | 6.81 | 237 |
| Comp B-3 ⁽⁷⁾ | 1.680 | 2.710 | 1.860 | 283 | 2.736 | 7.95 | 382 |
| TNB ⁽⁸⁾ | 1.640 | 2.318 | 2.025 | 219 | 2.356 | 7.27 | 307 |
| H-6 ⁽⁹⁾ | 1.760 | 2.832 | 1.695 | 245 | 2.759 | 7.40 | 360 |
| HBX-3 ⁽¹⁰⁾ | 1.850 | 3.134 | 1.605 | 206 | 3.095 | 7.53 | 370 |
| ATNB ⁽¹¹⁾ | 1.600 | 1.700 | 2.531 | 176 | - | 7.00 | 235 |
| DATNB ⁽¹²⁾ | 1.780 | 2.449 | 1.892 | 251 | 2.660 | 7.60 | 336 |
| TATNB ⁽¹³⁾ | 1.847 | 2.340 | 2.316 | 259 | 2.050 | 7.66 | 340 |

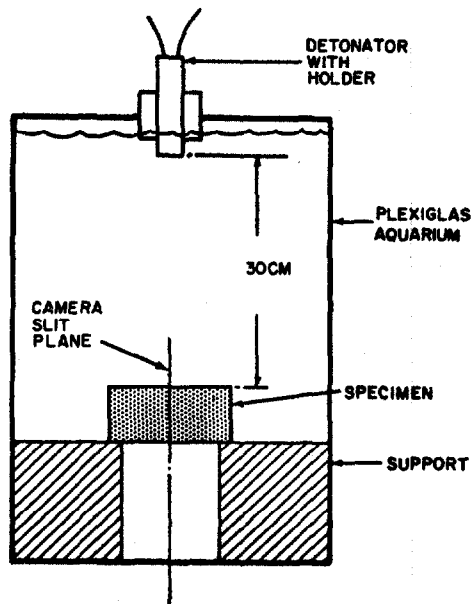

FIG 3. Arrangement for initiating and measuring weak shock waves (~100 bar)

Designations: 1 & 2 = Constants; 3 = Longitudinal sound velocity; 4 = Detonation velocity; 5 = Chapman-Jouguet pressure; 6 = 2,4,6-Trinitrotoluene, cast; 7 = RDX 60, TNT 40, cast; 8 = 1,3,5-Trinitrobenzene; 9 = RDX/TNT/Al/Wax - 44.8/29.5/20.9/4.8; 10 = RDX/TNT/Al/Wax - 31/29/35/5; 11 = 1-Amino-2,4,6-trinitrobenzene. It is designated in Ref 15a as TNA, which is a usual abbr for Trinitroaniline; 12 = 1,3-Diamino-2,4,6-trinitrotoluene, designated in Ref 15a as DATB, but we prefer DATNB; 13 = 1,3,5-Triamino-2,4,6-trinitrobenzene, designated in Ref 15 as TATB, but we prefer TATNB; 14 = Spike (or peak) pressure ahead of the detonation front; was determined accordg to vonNeumann theory. For this a linear extrapolation of the U_s-u_p data was conducted and assumption made that U_s-u_p relations represent nonreactive Hugoniot to the detonation velocities of expls

Coleburn and Liddiard listed about 30 refs connected with their work, of which the following seem to be the most important:
 a) W.B. Garn, JChemPhys **30**, 819 (1958)
 b) V.S. Ilyukhin et al, DoklAkadN **131**, 793 (1960) [Engl transl: SovietPhys-Doklady **5**, 337 (1960)]
 c) S.J. Jacobs et al, 9th-

SympCombstn (1963), 517 d) J.B. Ramsay & A.A. Popolato, 4thONRSympDeton (1965), 233-38 and e) R.J. Wesley & J.F. O'Brien, Ibid, 239

To these add the paper entitled "Determination of Shock Hugoniot for Several Condensed Phase Explosives", by V.M. Boyle et al, in 4thONRSympDeton (1965), pp 241-47

i) *Intermolecular Potentials, Equation of State Based on*. Fickett of Los Alamos Scientific Laboratory reported (Addnl Ref M₁) computations on IBM 7090 of properties of condensed expls (such as RDX) using LJD (Lennard-Jones & Devonshire) Equation of State (See item 1₄)

In order to understand the reason for calling LJD equation as the one "based on intermolecular forces", there is included a brief explanation based on the discussion given in the book of Hirschfelder, Curtis & Bird (Ref 8e, pp 22-3, 32, 35, 162-63 & 296)

It is known that two molecules attract each other when they are far apart and repel each other when they come close together. The "force of interaction", F , between two spherical non-polar molecules is a function of the "intermolecular separation", r . For most purposes, however, it is more convenient to use the "potential energy of interaction", $\phi(r)$, rather than the force of interaction $F(r)$. These two functions are simply related:

$$F(r) = -d\phi/dr \text{ and } \phi(r) = \int_r^{\infty} F(r)dr$$

These relations are valid only for force laws and potential functions which are functions of the intermolecular separation alone. For an angular dependent potential, the force on molecule is different and, in addition, there is a torque tending to rotate the molecule (Ref 8e, p 22)

For non-polar molecules, a commonly used "intermolecular potential energy factor" is the Lennard-Jones (6-12) Potential:

$$\phi(r) = 4\epsilon \left[\left(\frac{\sigma}{r} \right)^{12} - \left(\frac{\sigma}{r} \right)^6 \right],$$

where parameters σ and ϵ (which have dimensions of length and energy, respectively) are constants characteristic of the chemical species of the colliding molecules. Here σ

is that value of r for which $\phi(r)=0$. Parameter ϵ is the maximum energy of attraction (or depth of the potential well), which occurs at $r=2^{1/6}\sigma$ (Ref 8e, pp 22, 23 & 32)

For *polar molecules*, the most widely used intermolecular potential energy is the *Stockmayer Potential*:

$$\phi(r, \Phi_a, \Phi_b, \phi_b - \phi_a) = 4\epsilon \left[\left(\frac{\sigma}{r} \right)^{12} - \left(\frac{\sigma}{r} \right)^6 \right] - \left[\frac{\mu_a \mu_b}{r^3} \right] g(\Phi_a, \Phi_b, \phi_b - \phi_a),$$

in which $g(\Phi_a, \Phi_b, \phi_b - \phi_a)$ is the angular dependence of the dipole-interaction associated with the equation for rigid spheres containing a point dipole and for $r > \sigma$:

$$\phi(r, \Phi_a, \Phi_b, \phi_b - \phi_a) = - \left[\frac{\mu_a \mu_b}{r^3} \right] g(\Phi_a, \Phi_b, \phi_b - \phi_a),$$

where $g(\Phi_a, \Phi_b, \phi_b - \phi_a) = 2 \cos \Phi_a \Phi_b - \sin \Phi_a \Phi_b \cos(\phi_b - \phi_a)$

Stockmayer potential is considered as a superposition of a Lennard-Jones (6-12) potential and the interaction of two point dipoles. Many of the properties of gases and liquids have been calculated in terms of these two potential functions. It should be borne in mind, however, that Lennard-Jones and Stockmayer potentials are idealizations of the true energy of interaction and that they are reasonably accurate for a number of simple molecules. The interaction of long molecules, molecules in excited states, free radicals, and ions cannot be described by these two potential functions (Ref 8a, pp 23 & 35)

Since Lennard-Jones (6-12) potential has been widely used for calcn of properties of matter in the gaseous, liquid, and solid states, Hirschfelder et al (Ref 8e, pp 162ff) discuss it in detail. They show that the parameters σ and ϵ of the potential function may be determined by analysis of the second virial coefficient of the LJD equation of state

The most extensive calcns for LJD equation of state was performed by R.H. Wentorf et al. The results are reported in Ref 2f and Ref 8e, p 296

j₁) *Joffe Equation of State*. It is an equation of state for gases (proposed in 1947) (Ref 2a), in which all the constants are determined from

the value of "critical pressure" and "critical temperature" (qv). The eq may be written in generalized form and may be regarded as an analytical expression of the law of "corresponding states" (qv). The equation differs from generalized eqs proposed by Maron & Turnbull (Addnl Ref A₄) of Su & Chang (Ref 1h) in that no fitting of experimental data is required to obtain the values of the constants in the equation

It is assumed that the equation of the critical isothermal is:

$$p = RT/(V-b) - a/V(V-b) + c/V(V-b)^2 - d/V(V-b)^3 + e/V(V-b)^4 \quad (1)$$

The eq is of the 5th degree in the volume and differs in this respect from the eqs of van der Waals (qv), Berthelot (qv) and Clausius (qv) which are of the 3rd degree in the volume, and from the eq of Wohl (qv)

To obtain the values of "critical constants" (qv), the condition was imposed that the five roots of the eq (1) be equal to the "critical point" (qv). This leads to the relations for RT_c , a , c , d and e [shown on p 540 of Ref 2a as eq (3)] and substituting $b=V_c/4$ in (2), the eq (3) was obt'd:

$$\begin{aligned} RT_c &= 4p_c V_c \\ a &= 53p_c V_c^2/8 \\ c &= 270p_c V_c^3/64 \\ d &= 405p_c V_c^4/256 \\ e &= 243p_c V_c^5/1024 \end{aligned} \quad (3)$$

In evaluating the constants a , b , c , d and e with the aid of eq (3), the critical volume V_c can be eliminated thru the relation $V_c = RT_c/4p_c$ and the constants are computed from the exptl values of the critical temperature and pressure

In order to extend equation (1) to temperatures other than the critical, the temperature dependence of the constants a , b , c , d and e must be established. For this Joffe assumed, provisionally, that b is independent of the temperatures other than the critical and wrote the equation (1) in the following form:

$$p = \frac{RT}{V-b} - \frac{aT_c}{V(V-b)T} + \frac{cT_c^{3/2}}{V(V-b)^2 T^{3/2}} + \frac{dT_c^2}{V(V-b)^3 T^2} + \frac{eT_c^{5/2}}{V(V-b)^4 T^{5/2}} \quad (4)$$

This equation is also listed by Dunkle (Ref 10, p 182)

Eq (4) has been tested against Su & Chang's (Ref 1h) "generalized isometrics" based on data of several hydrocarbons and, for the purpose of this comparison, the equation is best written in reduced form accdg to the method suggested by them. Employing the ideal reduced volume $\phi = V_{p_c}/RT_c$, and denoting the reduced temp with θ and reduced pressure with π , eq (4) becomes:

$$\pi = \frac{16\theta}{16\phi-1} - \frac{53}{8\theta\phi(16\phi-1)} + \frac{135}{8\theta^3/2\phi(16\phi-1)^2} - \frac{405}{16\theta^2\phi(16\phi-1)^3} + \frac{243}{16\theta^5/2\phi(16\phi-1)^4} \quad (5)$$

The reduced pressures read from the generalized isometrics for the range covered $\phi=4$ to $2/7$ were compared with those calcd from eq (5), generalized Beattie-Bridgeman eq and Wohl eq. The total average per cent deviation was found to be 0.64% for eq.(5), 0.66% for BB eq and 0.81% for Wohl equation

In conclusion Joffe stated (Ref 2a, p 542), that his eq (4) is believed to reproduce the behavior of real gases with a higher degree of accuracy than the vanderWaals equation, and that in its reduced form, eq (5) represents an analytical expression of the law of "corresponding states" (qv)

j₂) Jones & Jones-Miller Equations of State. Accd to Cook (Ref 12, p 65-L), the Jones equation of state:

$$\alpha(T,v) = f(p)p^{-1}$$

may be considered as a general one

Jones & Miller adopted the form:

$$f(p) = b + cp + dp^2,$$

obtaining as the empirical constants the values $b=25.4$, $c=-0.104$, and $d=2.33 \times 10^{-4}$; p =pressure in megagram cm^{-2} and v =volume in $\text{cm}^3 \text{mol}^{-1}$

k₁) Keyes Equation of State. An equation of state for a gas, deduced from the concept of the nuclear atom. It was designed to correct the vanderWaals equation for the effect upon

the term b of the surrounding molecules:

$$p = RT/(V - Be^{-a/V}) - A/(V + \ell)^2$$

in which p =pressure, T =absolute temperature, V =volume, R =gas constant, e =base of natural logarithm 2.718 and A , a , B & ℓ are constants for each gas (Ref 8, p 404)

k₂) Kibara & Hikita Equation of State. The intermolecular potential $U(r) = \lambda r^{-n}$ ($\lambda > 0$ & $n > 3$) was used to introduce a theoretical equation of state for high temperature gases and its application to detonation phenomena was considered. In a 1-gram mass of gas composed of N identical molecules, occupying volume V , at absolute temperature T , the pressure p can be detd from eq:

$$p = \frac{NkT}{V} \left[1 + \sum_{t=0}^{\infty} B_t \left(\frac{N}{V} \right)^t \right]$$

where k =Boltzmann constant (qv) and B_t 's are virial coefficients which are quantities of the order of the $-t^{\text{th}}$ power of the molecular volume, where $t=1, 2, 3, \dots$; B_1, B_2, \dots are called the second, third, virial coefficients and are functions of T . Under the assumption of a fixed decompn eq, the variation of deton velocity with loading density was explained satisfactorily for PETN, TNT and Tetryl (Addnl Ref C, p 458 & Ref 10, p 182) (See also under "Intermolecular Potentials based on Equations of State")

k₃) Kistiakowsky-Halford-Wilson-Brinkley (KHWB) Equation of State, known also as Halford-Kistiakowsky-Wilson-Brinkley Equation of State. Accd to Cook (Ref 12, pp 62-3), the equation can be expressed as:

$$\alpha(T,v) = nRT_2 x e^{bx} / p_2 \quad (\text{Eq 4.16})$$

where $x = k(T+d)^a v^{-1}$; a =function of T & v ; T =absolute temperature, d =an arbitrary value in $^{\circ}\text{K}$, k =covolume constant, T_2 =absol temp of detonation and p_2 =pressure of detonation, a =constant originally assigned as $-1/3$, but later changed to $-1/4$; $b=0.3$; $d=0$ and e =base of natural logarithm. The covolume constant k was taken as an additive covolume constant by summing the values for each type of molecule weighted by its mole fraction. Each of the separate constants making up k

is adjusted empirically to obtain the best general agreement between observed and computed velocities. Thus, $k = \sum x_i k_i$, where x_i is the mole fraction of component i in the products of detonation and k_i a specific covolume constant for each of the species

The KHWB equation of state was employed by numerous investigators and found to be more or less satisfactory, especially after introducing some modifications. Cook (Ref 12, p 63) mentioned modifications by Fickett & Cowan, Paterson, Ratner, Caldirola, Murgai and Morris & Thomas

Cook adopted the "covolume approximation":

$$\alpha(T, v) = \alpha(v) \quad (\text{Eq 4.17})$$

and later he and his associates studied carefully the equations of state obtd by taking:

$$\alpha(T, v) = v(1 - e^{-x}), \quad (\text{Eq 4.18})$$

where $x = K(v)T^c v^{-1}$, employing various values of c and the "inverse method", i.e. by making use of exptl velocity data, to evaluate the function $K(v)$. By adjusting the c value, the above general eq of state can be made as nearly like any of the special forms employed. Thus, by taking $c = -0.25$, the equation will resemble closely the KHWB eq; for $c = 0$, it will become equivalent to the $\alpha(v)$ approximation; and for $c = 0.1$ it will correspond to an "unreal" eq of state with an attractive instead of repulsive potential, etc. The object of study by Cook et al was to determine systematically the influence of changes in the internal pressure p_i and corresponding internal energy E_i on the calculated detonation properties. The main conclusion of their study was described in Ref 12, p 63

k₄) Kistiakowsky-Wilson (KW) Equation of State. This equation developed before WWII for the gaseous detonation products of solid expls was described in Ref 1d. Cowan & Fickett (Addnl Ref E) have re-examined it in the light of new experimental data on detonation pressure and on the variation of detonation velocity D with loading density ρ_0 for several RDX/TNT mixtures. They proposed the following slightly modified version of KW equation of state:

$$pV_g/RT = F(x) + 1 + xe^{\beta x} \quad (1)$$

where $x = k/V_g(T + \theta)^a$ and $k = \kappa \sum x_i k_i$. Here p = pressure of gases of detonation; V_g = molar gas volume; R = gas constant; T = absolute temperature; F = function; x_i = mole fraction of component i , and the sum extends over all chemical components of the gaseous mixture. The quantities α , β , κ , θ , k_i are empirical constants, the k_i having the nature of covolumes (ie, a sort of excluded volume). The values $\alpha = 0.25$ and $\beta = 0.30$, which were chosen originally in 1943 to give agreement with experimental data, then available, proved later to be inadequate. It was found by Cowan & Fickett that the value $\beta = 0.30$, used by Kistiakowsky & Wilson, proved to be too high to match the observed slopes of $D - \rho_0$ curves for RDX/TNT explosives. The old value $\alpha = 0.25$ was found to be too small to match the "Chapman-Jouguet pressure", p_{CJ} of TNT alone. A suitable compromise for the above explosives was considered by Cowan & Fickett to be: $\alpha = 0.5$, $\beta = 0.09$ and $\theta = 400^\circ\text{K}$ (Addnl Ref E, p 932)

The calculations were complicated by the possible presence of solid carbon. It was assumed by C&F to be graphite and the following equation was proposed:

$$p = p_1(V_s) + a(V_s)T + b(V_s)T^2, \quad (2)$$

where p is in megabars and T in electron volts (ie in units of 11605.6°K)

$$p_1(V_s) = -2.467 + 6.769\eta - 6.956\eta^2 + 3.040\eta^3 + 0.3869\eta^4;$$

$$a(V_s) = -0.2267 + 0.2712\eta$$

$$b(V_s) = 0.08316 - 0.07804\eta^{-1} + 0.03068\eta^{-2}$$

with $\eta = V_s^0(T^0)/V_s = \rho/\rho_0$; or the ratio of the density of the solid at T, p to the crystal density at T^0, p^0 where p^0 is 1 atm. The numerical coefficients were obtd by fitting above eq (2) to points on the shock Hugoniot curve for graphite and to the compressibility and thermal expansion coefficient at normal density. The range of applicability is $0.95 < \eta < 2.5$ and $0 < T < 2$ (Addnl Ref E, pp 932-33) (See also Addnl Ref K₃ and Addnl Ref P)

k₅) Kury Equation of State. See under Wilkins Equation of State and equation (2) in Ref 15, p 7

1₁) *Landau-Stanyukovich (LS) Equation of State* (Uravneniye Sostoyaniya Landau i Stanyukovicha). This equation, suitable for calculating detonation products of condensed explosives, may be considered as a modification of "Abel Equation of State" (See item a₁). For a detailed description of LS equation, see Ref 1f; Ref 10, p 194; Ref 12a, p 246 and Ref 12b, Chapter 14. Briefly the equation is based on the assumption that decomposition products formed on detonation are, because of their high density, not gases, but rather liquids whose particles are in a state of oscillation. This conditions the course of expansion of the decomposition products. L & S replaced R of the Abel equation by a coefficient depending on the number of degrees of molecular freedom. We are not describing here the LS equation because the modification by Zel'dovich & Kompaneets seems to replace it (See next item 1₂)

1₂) *Landau-Stanyukovich-Zel'dovich-Kompaneets (LSZK)*. Derivation of this equation from that of Landau & Stanyukovich is described in the book of Zel'dovich & Kompaneets (Ref 12b, pp 223-28). A later description is given by Lutzky (Addnl Ref O):

"It is known that the energy of a solid body has a two-fold origin: it is made up of an elastic energy arising from the binding forces between the atoms and molecules and a thermal energy connected with oscillations of the atoms or molecules about their positions of stable equilibrium. Landau & Stanyukovich have attempted to describe the behavior of detonation products by considering it (the mixt) as a solid with the property that the elastic energy and the elastic part of the pressure are predominant. The theory has been described and expanded by Zel'dovich & Kompaneets, so that we refer to it as the LSZK theory" (Addnl Ref O, p 1)

The LSZK equation may be written:

$$p = \frac{B}{v\gamma} + \frac{C_v(\gamma/2 - 1/6)}{v} T \quad (1)$$

$$e = \frac{B}{(\gamma-1)v\gamma^{-1}} + C_v T, \quad (2)$$

where p = pressure, e = energy density (per unit mass); v = specific volume, T = temperature, γ = dimensional constant serving as a poly-

tropic index connected with the intermolecular forces, C_v = specific heat at constant volume, C_{v1} = specific heat associated with the appropriate lattice vibrations, and B = a constant having the units $(g/cm^3)^{1-\gamma}$ cal/g. The elastic part of the pressure is $B/v\gamma$, and $B/[(\gamma-1)v\gamma^{-1}]$ is the elastic part of the energy

Eliminating T between (1) and (2), one obtains the expression:

$$p = e/av + B/v\gamma \{1 - 1/[a(\gamma-1)]\}, \quad (3)$$

where $a = C_v/C_{v1} \cdot [1/(\gamma/2 - 1/6)]$ is a convenient variable

In terms of a , expression (1) and (2) may be written:

$$p = B/v\gamma + C_v T/av \quad \text{and} \quad (5)$$

$$e = B/[(\gamma-1)v\gamma^{-1}] + C_v T \quad (6)$$

Another convenient parameter is the quantity y , defined as the ratio of the thermal part of the pressure to the elastic part:

$$y = (C_v T/av) / (B/v\gamma) = [(C_v T) / (aB)] v\gamma^{-1} \quad (7)$$

This permits one to write (5) & (6) in the form of (8) & (9):

$$p = (B/v\gamma)(1+y) \quad \text{and} \quad (8)$$

$$e = (Ba/v\gamma^{-1}) \{y + 1/[a(\gamma-1)]\} \quad (9)$$

It is considered that the detonation wave consists of a shock traveling at velocity D , followed immediately by a region of *isentropic expansion* and that the region of chemical reaction behind the shock is infinitely thin

In the section "Isentropic Process" (Addnl Ref O, pp 4-5), Lutzky gives the following expressions for p , e & T as functions of density alone, valid for isentropic processes:

$$p(\rho) = K\rho^{(1+a)/a} + B\rho\gamma \quad (14)$$

$$e(\rho) = aK\rho^{(1/a)} + [1/(\gamma-1)]B\rho\gamma^{-1} \quad (15)$$

$$T = (aK\rho^{1/a})/C_v \quad (16)$$

He also gives for velocity of sound:

$$c^2 = K[(1+a)/a]\rho^{1/a} + B\gamma\rho\gamma^{-1} \quad (17)$$

In these expressions ρ is density and K is a constant of integration

In the section "Chapman-Jouguet Condition", Lutzky (Addnl Ref O, pp 6-8) deter-

mined several expressions in which subscript o signifies values of the hydrodynamic parameters in the undetonated section of explosive ahead of the shock

From the R-H (Rankine-Hugoniot) relations at the shock, there was obt'd:

$$v_o/v = D/(D-u), \quad (18)$$

where v_o = specific volume of the original expl, v = specific volume of products of detonation, u = particle velocity, and D = detonation velocity

Using the detonation property $D = u + c$, (19) equation (18) becomes:

$$v_o/v = u/c + 1 \quad \text{and} \quad u = (v_o/v - 1)c \quad (20)$$

Using $p = B\rho^\gamma(1+y)$ and other equations, c^2 may be obt'd as a function of ρ and y by eliminating K betw (14) and (17):

$$c^2 = B\rho^{\gamma-1} \{ \gamma + [(1+a)/a]y \} \quad (24)$$

and v_o/v as a function of y is

$$v_o/v = 1 + (1+y) / \{ 1 + [(1+a)/a]y \} \quad (25)$$

From Rankine-Hugoniot (R-H) equation for the energy, Lutzky obt'd the expressions:

$$e/Q = 1 + B/Q \{ [(1+y)^2 / 2v\gamma^{-1}] \{ 1 / [\gamma + y(1+a)/a] \} \} \quad (28)$$

and

$$e/B = B/Q \{ a/v\gamma^{-1} [y + 1/a(\gamma - 1)] \} \quad (29)$$

where Q is the chemical energy released by each gram of explosive

Equating (28) & (29) and solving for v , one obtains:

$$v\gamma^{-1} = B/Q \{ a\gamma + 1/(\gamma - 1) - (1+y)^2 / 2[\gamma + (1+a)/a]y \} \quad (30)$$

Eliminating v between (30) & (25), gives:

$$v_o = (B/Q)^{1/(\gamma-1)} [a\gamma + 1/(\gamma-1) - (y+1)^2 / 2w]^{1/(1-\gamma)} \cdot [1 + (1+y)/w] \quad (31)$$

$$\text{where} \quad w = \gamma + [(1+a)/a]y \quad (32)$$

Since v_o , the specific volume of the solid expl, is a known quantity, one may solve (31) for y by an iterative process. Since v is a known function of y [by virtue of (30)], one can determine p by using the expression: $p = B/v\gamma(1+y)$; ρ may be found from (28) or (29); and c^2 from (24)

The particle velocity at the front, u , may be found by replacing v_o/v in (20) with expression (25):

$$u = [c(1+y)] / \{ \gamma + [(1+a)/a]y \} \quad (33)$$

Finally, the deton vel can be found from (19) & (33):

$$D = u + c = c \{ 1 + (1+y) / [\gamma + [(1+a)/a]y] \} \quad (34)$$

Thus the detonation velocity is seen to be a function of v_o (Addnl Ref O, pp 6-8)

In the next section of Addnl Ref O, "Evaluation of Parameters", it is stated that the parameters, γ , a , and B/Q , which appear in the LSZK equation of state, must be evaluated by using experimental data and it is explained how this is done on pp 9-10. As an example, compressed TNT of various densities was investigated. Detonation velocities determined by LSZK expression (34) proved to be in good agreement with those det'd by the empirical formula:

$$D = 0.1785 + 0.3225\rho \text{ cm/microsecs,}$$

developed during WWII at the Explosive Research Laboratory, Bruceton, Pa. The results are given in Table of Addnl Ref O. The list of other C-J parameters det'd by Lutzky with the aid of LSZK equation of state, using for calculation an IBM-7090 computer, is given

Table 2

| | | | | | | |
|---------------------------|---------|---------|--------|---------|---------|---------|
| ρ_o (g/cc) | 1.625 | 1.59 | 1.45 | 1.30 | 1.14 | 1.00 |
| p (kbars) | 214.3 | 203.5 | 163.8 | 127.6 | 95.4 | 72.2 |
| ϵ (megabar-cc-g) | 0.06022 | 0.05973 | 0.0579 | 0.05607 | 0.05431 | 0.05293 |
| ρ (g/cc) | 2.217 | 2.171 | 1.988 | 1.792 | 1.583 | 1.400 |
| u (cm/ μ sec) | 0.188 | 0.185 | 0.175 | 0.164 | 0.153 | 0.144 |
| D (cm/ μ sec) | 0.703 | 0.691 | 0.646 | 0.598 | 0.547 | 0.503 |
| T (°Kelvin) | 582.9 | 698.4 | 1141.7 | 1582.5 | 2013.3 | 2356.7 |
| p (elastic) | 0.974 | 0.968 | 0.941 | 0.905 | 0.857 | 0.805 |
| P (total) | | | | | | |

in Table 2, which is also included here. The value of Q for TNT was taken as 1018 cal/g

Some parameters were detd in Russia by A.N. Dremin et al (Ref 13a, p 610) whose values check fairly well with those of Lutzky

Lutzky also detd the "flow field behind detonation shock" which is described on pp 11-12 of Addnl Ref O

In "concluding remarks", Lutzky stated that the calculation of C-J T with the help of LSZK equations, assuming $c_v = 0.3$ cal/g (approx average value for deton products), gave results which were too low at high densities (See Table 2). The reason for this is not known - probably it is due to incompleteness of LSZK theory. In any case, it is believed that in all applications where the calcn of T is not needed, and only an (e, p, v) equation of state is required (such as the calculation of the non-reactive, isentropic expansion of detonation products by means of hydrodynamic computer codes), the LSZK equation of state, in particular:

$$p = e/av + B/v^\gamma \{1 - 1[a(\gamma - 1)]\}, \quad (3)$$

$$\text{where } a = C_v/C_{v1} [1/(\gamma/2 - 1/6)] \quad (4)$$

may be used with confidence (Addnl Ref O, pp 13-14)

1₃) *Lees Equation of State* is one of the modifications of van der Waals equation of state:

$$(p + ap^{1/3}/Tv^{5/3})(V - b) = RT$$

The meanings of a, b, p, v, T & R are given in "Introduction" to the section on Equations of State

1₄) *Lennard-Jones & Devonshire (LJD) Equations of State*. For gases of low density, the following equation of LJD (Ref 1b, p 55) applies:

$$pV = NkT(1 + B/V), \quad (1)$$

where p = pressure, N = total number of molecules in a gas of volume V, k = Boltzmann constant (qv) and B = virial coefficient

This equation is valid under the same conditions as the van der Waals equation

For gases at moderate densities equations (19) and (20) are given in Ref 1b, p 59

Further in the paper there is a discussion of an attempt to find an equation of state of

a gas at high density in terms of interatomic forces. The main idea was that an atom in a dense gas can be regarded as confined for most of its time to a cell, and that its average environment is something like that of an atom in a liquid or crystal. The method did not attempt to calculate properties of a dense gas from binary encounters only, but considered an atom as subject to a multiple encounter all the time. The methods of statistical mechanics were used to derive an appropriate equation of state and the formulae were applied to the inert gases for which the interatomic fields are known. The calculated values of the critical temperature were found to be close to those observed

We give here the LJD equation of state in modified form, as listed in Ref 8e, p 297:

$$\frac{pV}{NkT} = 1 + \frac{24}{T^*} \left[\frac{1}{v^{*4}} \left(1.0110 + \frac{2G_L}{G} \right) - \frac{1}{v^{*2}} \left(1.2045 + \frac{2G_M}{G} \right) \right] \quad (\text{Eq 4.7-10})$$

where p = pressure, V = volume, N = Avogadro number, k = Boltzmann constant; the compressibility factor pV/NkT is given as a function of reduced temperature T^* and reduced specific volume v^* [reduced cell size, accdg to the Principle of Corresponding States (qv)]. The compressibility factor is plotted in Fig 4.7-3 on p 298 of Ref 8e and is given in tabular form in Table I-H, p 1122. The quantities G , G_L , and G_M are integrals like those for g , g_L and g_M , listed on p 295 of Ref 8e, except that the functions $l(y)$ and $m(y)$ are replaced by the functions $L(y)$ and $M(y)$, which are given on p 298. In Fig 4.7-2, p 297, reduced pressure p^* is shown as a function of v^* and T^*

In paper II on "Critical Phenomena in Gases" (Ref 1b₂), Lennard et al give a summary of work discussed in paper I (Ref 1b₁) and describe detn of vapor pressure and boiling points. They also propose on p 7 equation (26) as a new form of equation (20) which was given in paper I (Ref 1b, p 59)

The LJD equation is mentioned by Cook (Ref 12, p 64), but its formula not given

Dunkle (Ref 10, p 181) quoted Hirschfelder et al (Ref 8e), who on p 263 stated that "In detonation problems in which the pressure

may increase to 200000 atm, the Lennard-Jones & Devonshire equation of state might seem to be the most accurate representation. However, the Halford-Kistiakowsky-Wilson equation has been used to good advantage"

LJD equation of state is called by Fickett et al as "based on intermolecular potentials" (Ref 9e and Addnl Ref M₁) and also as "based on Lennard-Jones (6-12) potentials". The reasons for these names are given under "Intermolecular Potentials, Equations of State Based on"

Fickett et al (Addnl Ref M₁) give comparison of LJD equation with KW (Kistiakowsky-Wilson) and Constant- β equations of state

l₅) *Lorentz Equation of State*. Accd to Su & Chang (Ref 1_h, p 803), this equation, described by H.A. Lorentz in *WiedAnn* 12, 127 & 660 (1881), is:

$$p = \frac{RT}{V^2} [V + B] - \frac{A}{V^2},$$

where A & B are constant, p=pressure, T=abs temp, R=gas constant and V=volume

m₁) *Macleod Equation of State*. This is the vander Waals type equation which was developed in 1944 (Addnl Ref A₅ & Ref 13, p 15d). It assumes that the covolume is a function of the total (external + internal) pressure. This equation was discussed by Rush & Gamson (Addnl Ref A₆), whose nomenclature was used by Kobe & Murti (Addnl Ref J) and also used here. For one mole of gas the equation may be presented as:

$$\pi(v-b') = RT \quad (1)$$

where $\pi = p + a/v^2$ and $b' = A - B\pi + C\pi^2$ (2, & 3)

where b' represents the volume occupied by the molecules, p=pressure of gas, v=specific volume of gas, T=absolute temperature and R=gas constant. Values of a, A, B and C are given below as eqs 5a, 5b, 5c, 5d, 7a, 7b, 7c and 7d

Macleod showed that eq (1) is applicable to a variety of chemical compns with good agreement between calculated and observed

values. He also showed that for many substances $b' = V_c/2$, so that value of a can be calculated from critical values:

$$a = 2RT_c V_c - p_c V_c^2, \quad (4)$$

where p_c = critical pressure, T_c = critical temperature and V_c = critical volume

Once (a) is evaluated, three points can be selected on the critical isotherm and b' calcd for each point. The three values substituted into eq (3) give three eqs that can be solved simultaneously for A, B and C

Rush & Gamson (Addnl Ref A₆) showed that the constants of the Macleod equation are functions of the "critical constants" (qv) of the compound and the expressions obt'd by them were tabulated by Kobe & Murti (Addnl Ref J) and reproduced below:

$$a = f_1(p_c V_c^2) \quad (5a) \quad a = f_5(p_c V_{ci}^2) \quad (7a)$$

$$A = f_2(V_c) \quad (5b) \quad A = f_6(V_{ci}) \quad (7b)$$

$$B = f_3(V_c/p_c) \quad (5c) \quad B = f_7(V_{ci}/p_c) \quad (7c)$$

$$C = f_4(V_c/p_c^2) \quad (5d) \quad C = f_8(V_{ci}/p_c^2) \quad (7d)$$

For the constants a and A, the function was linear, but for B and C a smooth curve was obt'd.

In the above equations V_{ci} = ideal critical volume, which, accd to Su & Chang (Ref 1_h, p 802), can be determined from the eq:

$$V_{ci} = RT_c/p_c \quad (6)$$

Kobe & Murti determined by Macleod method values a, A, B & C for several compds which have been used by Rush & Gamson. These compds included: ethane, propane, pentane, heptane, cyclohexane, hydrogen, oxygen, benzene, CCl_2F_2 , carbon dioxide, decane and chlorine. The results were similar to those reported by R & G but better correlation was obt'd

Rush & Gamson also found that in order to apply eq (1) to mixtures, it is necessary to use an empirical factor 1.08, thus giving:

$$(p + a/V^2)(V - 1.08b') = RT,$$

but with correlation based on ideal critical volume V_{ci} , Kobe & Murti found that it is not necessary to use the factor 1.08 in their modification

m₁ bis) *Maron and Turnbull Equation of State*. An empirical equation using the principle

of "corresponding states" was developed for gases and was found to be applicable to pressures as high as 1000 atm and "reduced temperatures" of $T_r = 1.55$ and above. The equation was derived from:

$$pV = RT + a'_1 p + a'_2 p^2 + a'_3 p^3 + a'_4 p^4, \quad (1)$$

where the virial coefficients a'_{1-4} are functions of the temperature only, and are given by equations (2), (3), (4) & (5) listed in Addnl Ref A₄, p 2195. This does not end the calculations because seven more equations have to be derived. Although this equation gives smaller deviations than van der Waals equation, it does not seem to be superior to simpler equations which were derived after WWII

m₁ tris) *Mayer & Careri's Equation of State Computation*. There existed in 1952 three general approaches to the calcn of the equation of state of a macroscopic systems of molecules, if one assumed that the forces between the individual molecules were known:

- 1) The calculation of virial coefficients
- 2) The method of integral equations and
- 3) The cell method or free volume method

After examining these methods, Mayer & Careri (Ref 7b) suggested a procedure for computing exactly the thermodynamic functions of a nonequilibrium system. The state of the system was then varied, at fixed volume and temperature, so as to give a minimum Helmholtz free energy, consistent with such conditions as are imposed to permit the exact computation. The condition under which this method leads to self-consistent equations is discussed in detail. The method is then applied in a way that is very close to the Lennard-Jones and Devonshire cell method, but with cells of variable size. The distribution within a cell is assumed to be Gaussian. Mayer & Careri claimed that the method is easier to apply than the cell method, but it seems to be rather complicated

m₂) *Mie-Grüneisen and Grüneisen-Type Equations of State*. In the paper of W.H. Andersen, "Evaluation of Grüneisen Parameter for Compressed Substances" (Ref 15, pp 205-12), the Mie-Grüneisen Equation is given as:

$$P - P_k = (\gamma/V)E_{th} = (\gamma/V)(E - E_k), \quad (Eq 3)$$

where p =pressure, k =subscript indicating the quantity is to be evaluated as a function of volume V at $0^\circ K$, E_{th} = thermal energy being equal to $C_v T$, where C_v is constant-volume heat capacity and γ =Grüneisen parameter

$$\gamma = -d \ln \nu / d \ln V, \quad (Eq 2)$$

where d =differential, V =volume and ν =vibrational frequency

The original expression for Grüneisen parameter was:

$$\gamma = \alpha v_o / \beta C_v, \quad (Eq 4)$$

where α =coefficient of thermal expansion, β =coefficient of compressibility and v_o = normal specific volume of the substance

The Grüneisen parameter essentially controls the partitioning of the compression energy into thermal and potential energy. Its value decreases with increased compression (decreased specific volume)

W.H. Anderson noted under "Comments" on the paper of J.W. Kury et al, "Metal Acceleration by Chemical Explosives" (Ref 15, p 13), that a Grüneisen type of equation should be applicable in describing the state & behavior of the detonation products for an explosive whose charge density is ca 1 g/cc or higher. For such explosives, the detonation products are initially (before expansion) in a repulsive-interaction potential energy state, as was previously pointed out by S.R. Brinkley, Jr. Because of this repulsive molecular interaction, the translational and rotational degrees of freedom of the molecules become vibrational in nature

The Grüneisen-type equation predicts a pressure, in the adiabatic expansion of the products, which initially falls more rapidly with increase in volume than does the pressure predicted for a constant-gamma-law gas. The predicted adiabatic exponent increases with increase in volume, until the volume corresponding to the minimum in the interaction potential energy is reached. These predictions were borne out by the experimental data reported by J.W. Kury et al (Ref 15, pp 3-12)

As the volume increases further, the

Grüneisen equation is no longer strictly valid, but all variable-covolume equations of state predict a decrease in the adiabatic exponent to its low-pressure value of about 1.3. The Grüneisen equation reverts to a constant-gamma-law form as the interaction terms vanish. The initial decrease in the exponent results from the increase in the Grüneisen parameter to its value at the potential energy minimum. This tends to rapidly reduce the thermal energy of the gas available for doing work as the detonation products expand (Ref 17)(See also Ref 15, pp 205-12)

m₃) *Murgai Equation of State*. It is a modification of the Corner Equation of State and was described in Vol 3 of Encycl, p C542-R. See also Ref 9 & Addnl Ref D in this section

m₄) *Murnaghan Equation of State*. See under Fürth Equation of State

n) *Noble-Abel (NA) Equation of State*. It is one of the "Covolume Equations of State" and was described in Vol 3 of Encycl, p C550-R under Covolume

When applied to deflagration of propellants, it can be written in the form:

$$pV = a + p\eta,$$

where η , known as "covolume of propellant", is positive and varies slowly with volume of deflgrn products V . It can be evaluated from equation:

$$\eta = V - a/p,$$

where a value a is chosen to make η as constant as possible (Ref 5, p 100 & Ref 6, p 53)

Accdg to Corner (Ref 5, pp 100-01), there have been several attempts to find a better equation of state than the Noble-Abel equation, but they were more complicated and do not seem to be a great improvement. As the covolume alters by less than 1% in the range of 2000-3000°K for a typical proplnt, the NA equation with a constant covolume represents fairly accurately the observed values of the product gases in guns

p₁) *Pack-Evans-James Equation of State*. See under Fürth Equation of State

p₂) *Pike Equation of State*. See under Wilkins Equation of State and also in the paper by J.W.S. Allan & B.D. Lambourn, "An Equation of State of Detonation Products at Pressures Below 30 Kilobars" (Ref 15, pp 53-4)

p₃) *Plank Equation of State*, proposed in 1936 (Addnl Ref A₂), is a virial equation of the 5th degree in volume of the form:

$$p = \frac{RT}{(V-b)} - \frac{A_2}{(V-b)^2} + \frac{A_3}{(V-b)^3} - \frac{A_4}{(V-b)^4} + \frac{A_5}{(V-b)^5}$$

Accdg to Joffe (Ref 2a, p 541, footnote 5), no general law for the variation of the coefficients A_2 , A_3 , A_4 & A_5 with temperature has been advanced by Plank

p₄) *Polytropic Equations of State*. A simplified form, very useful in explosives calculations is obtained by assuming that the explosion products behave as a polytropic gas, ie, an ideal (perfect) gas having constant specific heats and, hence, a constant value of specific heat ratio, known as *polytropic exponent gamma* (γ)

The *polytropic equation of state*, also known as *gamma law equation of state* can be expressed as:

$$pV^\gamma = \text{constant}$$

The polytropic law for gaseous detonations can also be expressed as:

$p = A(S)\rho^n$ or $p = A(S)\rho^\gamma$ (as given on p 41 of Ref 19) and $\ln p/p_0 = \ln \rho/\rho_0$

with n (or γ) known as adiabatic exponent, equal to about 3. It was found to approximate the actual density-pressure relationship in detonation, just as well as more complex equations of state. Its plot of $\log p/p_0$ vs $\log \rho/\rho_0$ is a straight line of slope 3 passing thru the origin (Ref 10, p 186)

In the above equations: p = pressure of detonation gases, p_0 = initial pressure, $A(S)$ (which means that A is function of entropy S)

is equivalent to $p/p_0 = (\rho/\rho_0)^n$, where ρ_0 = initial density of gas, ρ = density of gases of detonation and n = adiabatic exponent

Accdg to Dunkle (Ref 10, p 184), L.H. Thomas stated in BRL Rept 475 which was conf in 1944, but apparently declassified now, that if the relation between P and ρ for TNT detonation products is fitted roughly to the equation $p = A(S)\rho^n$, n must be taken as about 2.75. Here S means entropy.

The value 3 can be used for n in obtaining a solution of hydrodynamic equations for an ideal gas by the method of characteristics since this value makes for easy solution. These solutions describe roughly the propagation of finite waves thru a solid since most solids follow approximately the ideal gas adiabat with $\gamma = 3$. This value of γ is not to be confused with the true ratio of specific heats, which lies between 1 and 1-2/3 (Ref 10, p 184 & Ref 8e, p 740)

Berry & Holt (Ref 8d, p 2) assumed polytropic equations of state for both an explosive gas and surrounding air; n was taken as 3 thruout the expl gas, 1.2 in the disturbed air region, and 1.4 in the undisturbed air. They stated that the value 3 "is accepted for the description of the state of an explosive gas ... near the detonation front, and leads to a simplification in the equations of motion" (Quoted from Ref 10, p 184)

Holt later added (Ref 8f, p 1): "In the explosive gas a polytropic law with $\gamma = 3$ is satisfactory near the detonation front but leads to an excessive expansion of the gas away from this; in the disturbed air it is again inaccurate to take a fixed value of γ thruout the region of intense compression behind the main blast wave". He added in the summary: "Most of the properties established for polytropic explosives with $\gamma = 3$ are found to be generally true" (Quoted from Ref 10, pp 184-85)

I.C. Skidmore & S. Hart in the paper, "The Equation of State of Detonation Products Behind Overdriven Detonation Waves in Composition B" (Ref 15, pp 47-52), stated that experiments conducted in England have shown that in many high explosives the shock compressions and adiabatic expansions of

the detonation products from the C-J (Chapman-Jouguet) state are consistent with a polytropic gas equation of state having an adiabatic exponent γ equal to about 3. Such an equation is applicable to pressures above 100 kbars, but cannot account for the variation of detonation velocity with loading density. In some applications of explosives, detonation waves are overdriven to pressures considerably higher than the C-J pressure. Techniques for formation in the laboratory of such waves and a successful application of the polytropic equation of state for prediction of their detonation properties are described under Skidmore & Hart Equation of State (See also under Wilkins Equation of State)

r_1) *Rankine-Hugoniot (RH) Equations.* See under Hugoniot and Rankine-Hugoniot Equations and also under Skidmore & Hart Equations of State

r_2) *Reduced Equation of State.* See under "Introduction" to this section on Equations of State

s_1) *Skidmore & Hart Equations of State.* The following description is given by I.C. Skidmore & S. Hart on pp 47-51 of Ref 15, except that some caps are replaced with small letters to be comparable with designations given by Cook
Theory. If p is pressure, v - specific volume, e - specific internal energy, D - detonation velocity, u - particle velocity, C - sound velocity, γ - adiabatic exponent and q - specific detonation energy, the velocity of propagation and particle velocity immediately behind any plane detonation wave in an explosive, defined by initial conditions, p_0 , v_0 , e_0 , and u_0 , are given by the first two *Rankine-Hugoniot* relations:

$$D = u_0 + v_0 [(p - p_0) / (v_0 - v)]^{1/2} \quad (1)$$

$$u = u_0 + \{ (p - p_0)(v_0 - v) \}^{1/2} \quad (2)$$

The pressure and volume of the detonation products immediately behind the detonation front are related by the third *Rankine-Hugoniot* equation which defines the

Hugoniot curve:

$$e - e_0 = q + \frac{1}{2}(p + p_0)(v_0 - v) \quad (3)$$

If the detonation products obey a polytropic gas equation of state, then:

$$e = pv^{(\gamma-1)} \quad \text{and} \quad (4)$$

$$C^2 = \gamma pv \quad (5)$$

For a steady unsupported detonation wave with properties designated by subscript 1, the C-J condition is:

$$C_1 = D_1 - u_1 \quad (6)$$

In solid explosive initially at atmospheric pressure p_0 (which is negligible in comparison with p_1), one obtains after substituting Eqs (1), (2) & (5) in (6), the following:

$$v_1/v_0 = C_1/D_1 = \gamma(\gamma+1) \quad (7)$$

For initial particle velocity v_0 equal to zero, Eqs (1)-(4) with the simplification provided by Eq (7), will give:

$$D_1^2 = (\gamma+1)^2 u_1^2 = (\gamma+1)p_1 v_0 = 2(\gamma^2-1)(q+e_0) \quad (8)$$

For an *overdriven detonation wave*, in 60/40-RDX/TNT explosive, with properties designated by subscript 2, Eqs (6) & (8) no longer hold so that Eqs (1)-(4), simplified using Eq (8), give Eq (9), which is independent of γ :

$$\frac{D_1}{D_2} = \left[\frac{p_1}{p_2} \left(2 - \frac{p_1}{p_2} \right) \right]^{1/2} = \frac{2u_1/u_2}{1+(u_1/u_2)^2} \quad (9)$$

The p-u locus for reflected shocks in the detonation products is given by Eq (2) with subscript 2 replacing 0 and the sign of the last term changed:

$$u = u_2 - [(p-p_2)(v_2-v)]^{1/2}$$

The same transformation in Eq (3) with $Q=0$ gives the *Hugoniot curve for reflected shocks* so that by eliminating v the following equation is obtained:

$$u = u_2 - C_2(p/p_2 - 1) \left[\frac{2/\gamma}{(\gamma+1)p/p_2 + (\gamma-1)} \right]^{1/2} \quad (10)$$

For reflected rarefaction waves the adiabatic relation $pv^\gamma = p_2 v_2^\gamma$ holds and the p-u locus is given by:

$$u = u_2 + \frac{2C_2}{\gamma-1} \left[1 - (p/p_2)^{(\gamma-1)/2\gamma} \right] \quad (11)$$

In experiments of Skidmore & Hart, the *overdriven detonation waves* were generated by an "explosive driven plate impact technique", which was essentially as follows (Ref 15, p 48):

A metal plate ("driver") of mild steel or brass was propelled explosively against a similar plate ("target") on which was resting a sample layer of explosive backed by a further layer of an inert solid. When the driver plate velocity was sufficiently high, this process generated a steady "overdriven" detonation wave in the explosive unless (or until) it was overtaken by the rarefaction from the rear of the driver plate. The shock transit times thru each layer of the system were measured to determine the transmitted shock or detonation velocities. The measured driver plate impact velocity or the shock velocity in the target plate, whose shock properties are known, defined the incident shock strength. An impedance match at the target plate-explosive interface using the measured overdriven deton velocity then defined the corresponding detonation pressure and particle velocity

The properties of reflected waves in the deton products were determined by a similar impedance match at the explosive-backing plate interface using the measured transmitted shock velocity in the backing plate whose Hugoniot curve was known. This technique was described by Al'tschuler et al (Addnl Ref F1) for determining the shock properties of inert solids. The investigated expl, Comp B-3 (60/40-RDX/TNT) had loading density 1.65 g/cc, with C-J properties $D_1 = 7.74$ mm/ μ sec, $u_1 = 2.01$ mm/ μ sec, $p_1 = 257$ kbar, corresponding to $\gamma = 2.85$

Mean results for overdriven deton waves were found to be: $D_2 = 8.00$ to 9.00 mm/ μ sec, $p_2 = 346$ to 520 kbar and $u_2 = 2.62$ to 3.53 mm/ μ sec; mean results for reflected waves in overdriven RDX/TNT expl were found to be for brass of density 8.44 g/cc; shock velocity 5.79 mm/ μ sec; pressure 689 kbar; and particle velocity 1.41 mm/ μ sec (Ref 15, pp 48-9)

In Fig 1 of Ref 15, p 50, the overdriven experimental deton velocities were plotted

as a function of deton pressure and compared with the predictions of equation (9)

In Fig 2 of Ref 15, p 51 the corresponding comparison was made in the pressure-particle velocity plane. Also in Fig 2, the reflected wave data were compared with equations (10) & (11) using the value of γ appropriate to C-J state

Relative errors were below 3% for the overdriven states and generally higher for reflected wave data

Equations described here are applicable only at deton pressures above ca 100 kbars

s.) *Su & Chang Equations of State.* There are three equations proposed by Su & Chang: 1. Generalized Beattie-Bridgeman Equation of State for Real Gases. It is written by Su & Chang as:

$$\pi = \frac{\theta(1-\epsilon')}{\phi^2} [\phi+B'] - \frac{A'}{\phi^2}$$

where $\pi = p/p_c$ (reduced pressure), $\theta = T/T_c$ (reduced temperature), $\epsilon' = c'/\phi\theta^3$, $\phi = V/V_{ci}$ (ideal reduced volume), $V_{ci} = RT_c/p_c$ (ideal critical volume), $A' = A'_0(1-a'/\phi)$, $B' = B'_0(1-b'/\phi)$; subscript c means critical and i means ideal

The constants $A'_0 = 0.4758$, $B'_0 = 0.18764$, $a' = 0.1127$, $b' = 0.03833$ and $c' = 0.05$ have the same numerical values irrespective of the chemical nature of the gas

It was found that this generalized equation held for seventeen gases investigated by Su & Chang with an average deviation of 2% or less (Ref 1h)

2. Generalized van der Waals Equation of State for Real Gases. The proposed generalized equation is:

$$\pi = \frac{\theta}{\beta - \phi} - \frac{a}{\phi^2}$$

where $\pi = p/p_c$ (reduced pressure), subscript c signifies critical value, $\theta = T/T_c$ (reduced temperature), $\phi = V/V_{ci}$ (ideal reduced volume); $V_{ci} = RT_c/p_c$ (ideal critical volume, ie volume occupied by one mole of perfect gas at the critical temperature and critical pressure); a and β are generalized van der Waals constants equal to $27/64 = 0.422$ and to $1/8 = 0.125$, res-

pectively; they are universal, dimensionless constants and are the same for all gases.

Results of calculations for ten gases are given (Ref 1i, pp 800-02)

3. Generalized Equation of State for Real Gases, which can be applied from low densities to about twice the critical density is:

$$\pi = \frac{\theta}{\phi^2} [\phi+B] - \frac{A}{\phi^2} \text{ with } B = B_0(1 + \frac{b}{\phi})$$

Here the terms π and θ have the same meaning

as in the previous equation; $\phi = \frac{V}{RT_c/p_c}$, called "ideal reduced volume"; A , B_0 and b generalized constants independent of the nature of gas are equal to 0.472, 0.160 and 0.190, respectively. Detailed description of calculation and results for 12 gases are given in Ref 1i, pp 802-03

Su & Chang stated that their equation falls into the general form of the Lorentz Equation of State (qv). It may also be regarded as a simplified, generalized form of Beattie-Bridgeman Equation of State (qv)

v₁) *Van der Waals Equation of State.* It is listed in Vol 3 of Encycl, p C550-R, under "Covolume" and fully described in the "Introduction" to this section on Equations

v₂) *Virial Equations of State.* Any equation of state which contains constants known as *virial coefficients*, is known as a *virial equation*, or sometimes "general equation of state" (See item j₂)

Accdg to footnote 1, p 3 in the book of Hirschfelder et al (Ref 8e), the word "virial" is derived from the latin "vis" (pl "vires") which means "force". The "virial" is a quantity defined in terms of the forces acting on the molecules. The "virial coefficients" give the deviations from ideality in terms of the forces between molecules

If p is pressure, V = volume and $B(T)$, $C(T)$ and $D(T)$ are temperature dependent functions which are referred to as the 2nd, 3rd and 4th "virial coefficients", then a "virial equation of state" suitable for gases of low and moderate pressure over a large

range of temperature and pressure can be expressed as:

$$pV/RT = 1 + B(T)/V + C(T)/V^2 + D(T)/V^3 + \dots$$

[Compare with eq (1.1-2), p 2 and eq (3.0-1), p 131 of Ref 8e]

This equation is of the "third degree", because it contains three virial coefficients B(T), C(T) and D(T)

The Boltzmann equation (See item b₆) is also of the third degree, but Hirschfelder & Roseveare's modification of Boltzmann equation (See under item b₆) is of the fourth degree

Joffe proposed a virial equation of state of the fifth degree (See item j₁)

Other virial equations are those of Kihara & Hikita (item k₂) and of Lennard-Jones & Devonshire (item l₄)

w₁) Wilkins Equation of State and Its Modifications. The polytropic equation of state written in the form:

$$p = (\gamma - 1)E/v$$

yields the adiabat $p v^\gamma$. Here p = pressure, v = specific volume, E = internal energy (including chemical energy) per unit mass and $\gamma = (d \log p)/(d \log V)/\text{adiabat}$

Accdg to Dunkle (Ref 17), this equation can serve for detonation pressures above 150-200 kilobars, but at lower and higher pressures the equation proves to be inadequate. Modifications were proposed to adjust to the situation, among them that of M.L. Wilkins et al in the paper: "The Equation of State of PBX 9404 and LX04-01" (Ref 14, p 769-78). Wilkins equation is:

$$p = a\eta^Q + B(1 - \omega\eta/R)^{-R/\eta} + \omega\eta E$$

For two explosive compositions: PBX 9404 (HMX 94, NC 3 & tris- β -chloroethylphosphate 3%) and LX04-01 (HMX 85 & Viton A 15%) the following values of the parameters were determined:

| | PBX 9404 | LX04-01 |
|-----------|-------------------------|-------------------------|
| a | -4.563×10^{-3} | -8.335×10^{-4} |
| η | 0.7266 | 0.7316 |
| Q | 4 | 4 |
| R | 4 | 4 |
| B | 6.572 | 5.943 |
| ω | 0.35 | 0.40 |
| E_0/v_0 | 0.1343×10^{12} | 0.1126×10^{12} |
| | ergs/original volume | |
| p | 0.39 | 0.36 |
| | megabars | |

The value η was calcd from the equation

$$\eta = v/v_0 = \rho/\rho_0$$

where density, ρ_0 , for PBX 9404 was 1.84 g/cc and for LX04-01 1.86 g/cc

Detonation velocities were found to be 0.88 cm/ μ sec and 0.848, respectively (Ref 14, p 773)

J.W. Kury et al in the paper: "Metal Acceleration by Chemical Explosives" (Ref 15) stated on p 7 that Wilkins, in his earlier paper (Addnl Ref O₁), was able to describe p-v-E (pressure-sp vol-energy) data obt'd when a sphere of explosive expanded an Al shell, by the expression:

$$p = A/v^Q + B(1 - \omega/R_1 v)e^{-R_1 v} + \omega E/v \quad (1)$$

where Q=4 and A, B, R₁, E, R₂ & ω are given after the eq (3)

This equation was modified by Kury et al when their experimental data were extended to lower pressures with cylinder test results

The equation modified by Kury et al is:

$$p = A(1 - \omega/R_1 v)e^{-R_1 v} + B(1 - \omega/R_2 v)e^{-R_2 v} + \omega E/v \quad (2)$$

The equation for p as a function of v at constant entropy S is:

$$p_S = A e^{-R_1 v} + B e^{-R_2 v} + C v^{-(\omega+1)} \quad (3)$$

The constants in eq (2) were evaluated for Comp B, Grade A (RDX/TNT-64/36) expl using the experimental p_{CJ} and data from cylinder and sphere tests. They are: $\rho_0 = 1.717$ g/cc, $D = 0.798$ cm/ μ sec, $P_{CJ} = 0.295$ megabar, $R_1 = 4.2$, $R_2 = 1.1$, $\omega = 0.34$, $A = 5.24229$, $B = 0.076783$ and $E = 0.085$ megabar cc/gm (Ref 15, p 8). Subscript S indicates entropy, C = constant (not explained),

and e = base of natural logarithm

Accdg to S.W.S. Allan & B.D. Lambourn, "An Equation of State of Detonation Products at Pressures Below 30 Kilobars" (Ref 15, pp 52-66) and C.G. Dunkle (Ref 17), H.H.M. Pike of AWRE, England, has generalized Fickett & Wood's adiabatic relation (Addnl Ref &, p 528) to:

$$P_r(v) = Av^{-\delta} + wGv^{-(1+w)} \quad (15)$$

where v = specific volume, $P_r(v)$ = pressure on the "reference curve" as function of v , A & G are constants, $\delta = \gamma_{CJ}$ = adiabatic exponent which may be considered essentially constant over the range 1 to 500 kbar, and $w = G_{\text{Grüneisen}}$ ratio which also can be considered constant. The reference curve for detonation products may be taken to be the C-J adiabat so that:

$$e_r(v) = \int_v^{\infty} P_r(v) dv, \quad (16)$$

ie, the origin of specific internal energy, e_r , is taken to be zero at infinite expansion (Ref 15, p 53)

The adiabat is curved concave upwards, and has an adiabatic exponent which tends to approach $1+w$ at very low pressures

In order to obtain the dip in the adiabat below the constant γ form, Wilkins, accdg to Allan & Lambourn (Ref 15, p 54), added an exponential term to the Pike form, giving:

$$P_r(v) = Av^{-\delta} + B \exp(-kv) + wGv^{-(1+w)} \quad (16a)$$

where B and k are constants

Wilkins also gave sets of constants A , δ , B , k , G & w for two expls. One significant fact about the values is that A is small and negative. Since it is negative, there must be some value of v for which the adiabat turns over and has an unreal slope, though this value is at very high pressure and out of the region of interest. The fact that A is small suggests that the whole term $Av^{-\delta}$ may be neglected, leaving what may be called exponential equation of state:

$$P_r(v) = B \exp(-kv) + wGv^{-(1+w)} \quad (17)$$

This adiabat has all the properties of the Wilkins equation of state for $p < p_{CJ}$, ie, it has the dip below the constant γ adiabat and it has a γ tending to approach $1+w$ at low pressure. It has the advantage over the

Wilkins equation in that there are now only 4 constants to determine instead of 6. However, there are two disadvantages of equation 17

1. When the exponential term dominates, the adiabatic exponent is $\gamma = kv$ which means that it decreases with decreasing volume. The behavior is therefore poor at high pressures
2. The p - v relation for the adiabat 17 tends to fall off too rapidly from the constant γ adiabat

To overcome these difficulties, Allan & Lambourn (Ref 15, p 54) proposed that the two explosives examined by them:

- a) HMX/TNT/Inert-68/30/2 and b) HMX/Inert-95/5, use the Pike equation:

$$P_r(v) = Av^{-\delta} + wG_1 v^{-(1+w)} \quad (18a)$$

for volumes equal to or less than some critical volume v_c and to use the exponential equation:

$$P_r(v) = B \exp(-kv) + wG_2 v^{-(1+w)} \quad (18b)$$

for v greater than v_c

We call the equations 18a and 18b the Allan-Lambourn equations, although they are actually modifications of Wilkins, Pike and Fickett-Wood equations

Application of these equations to determination of detonation properties of the above explosives is described in detail in Ref 15, pp 55-66

w₂) *Wohl Equation of State*. It is the 4th degree in the volume virial equation proposed in 1914 by Wohl and described in Addnl Ref A₁. It was used by Joffe (Ref 2a) for calcn of parameters of some gases in order to compare the results with those obt'd by using the eq (5) of Joffe with equation of Beattie-Bridgeman and van der Waals

Joffe gives (Ref 2a, p 541) for Wohl equation:

$$p = RT/(V-b) - a/V(V-b) + c/V^3$$

We did not study the paper of Wohl

z) *Zel'dovich & Kompaneets' Refined Analysis of the Equation of State of the Explosion Products*. A detailed description of formulation of a theory of the detonation of condensed explosives, assuming that the total pressure

is of elastic origin, while only the energy has a thermal part, is given in Ref. 12b, Section 20, pp 228-46

(See also Landau-Stanyukovich-Zel'dovich-Kompaneets Equation of State)

- Refs: 1a) R. Becker, *ZPhysik* **4**, 393 (1921); *Ibid* **8**, 321 (1922) and *ZTechPhysik* **3**, 249 (1922) (Equation of state) 1b₁) J.E. Lennard-Jones & A.F. Devonshire, *ProcRoySoc.* **163A**, 53-70 (1937) (Critical Phenomena in Gases-I) 1b₂) *Ibid*, **165A**, 1-11 (1938) (Critical Phenomena in Gases-II) 1c) J.O. Hirschfelder & W.E. Roseveare, *JPhysChem* **43**, 15 (1939) (Modification of Boltzmann equation of state) 1d) G.D. Kistiakowsky & E.B. Wilson, Jr, *OSRD* **69** (1941) (Calculation of detonation velocity using Becker equation of state); *Ibid* *OSRD* **114** (1941) (Calculation of deton vel using more general Becker equation of state) 1e) S.R. Brinkley, Jr & E.B. Wilson, Jr, *OSRD* **1707** (1943) (Determination of detonation velocities of some pure explosives) 1f) L.D. Landau & K.P. Stanyukovich, *ComptRendAcadSci (Russia)* **46**, 362-64 (1945) and *DoklAkadN* **46**, 396-98 (1945); *CA* **40**, 4523-24 (1946) (Derivation of equation of state applicable to products of detonation of condensed explosives) 1g) R.A. Connor, Ed, "Summary Technical Report of Div 8 NDRC", Vol 1 (1946), Chapter 5, "The Theory of Detonation Process" (Based on Summary by S.R. Brinkley, Jr) 1h) G.J. Su & C.H. Chang, *JACS* **68**, 1080-83 (1946) (Equation of state for real gases) 1i) *Ibid*, *IEC* **38**, 800-02 & 802-03 (1946) (Equations of state for real gases) 1j) M.A. Cook, *JChemPhys* **15**, 518-24 (1947) (An equation of state at extremely high temperatures and pressures from the hydrodynamic theory of detonation) 2a) J. Joffe, *JACS* **69**, 540-42 (1947) (A new equation of state for gases) 2b) *Ibid*, **69**, 1216-17 (1947) (A modification of Dieterici equation of state) 2c) G. Morris & H. Thomas, *Resear ch (London)*, **1**, 132-44 (1947) (Equations of state) 2d) S. Paterson, *Ibid*, **1**, 221 (1948) (Equation of state) 2e) M.A. Cook, *JChemPhys* **16**, 554-55 (1948) (An equation of state at extremely high temperature from hydrodynamic theory of detonation) 2f) R.H. Wentorf et al, *JChemPhys* **18**, 1484-1500 (1950) (Lennard-Jones and Devonshire equation of state of compressed gases and liquids) 3) S.G. Starling & A.J. Woodall, "Physics", Longmans-Green, London (1950), 264 & 273 3a) S. Travers, *MAF* **24**, 443-50 (1950) (Pure shock waves) 4) G.B. Kistiakowsky, p 951 in Kirk & Othmer **5** (1950), pp given in the text; (Not included in the 2nd edition) 5) Corner, *Ballistics* (1950), 100-01 (Corner & Noble-Abel equations of state) 6) SACMS, *Ballistics* (1951), 18 (Covolume and equation of state of proplnt gases) 7) Taylor (1952), 34 (Boltzmann and Hirschfelder & Roseveare equation of state for the expln products); 69-72 (Rankine-Hugoniot equation of state); 87-98 (Abel, Boltzmann and other equations of state applicable to deton of condensed expls yielding only gaseous products); 114 (Equations of state applicable to deton of condensed expls whose products contain a condensed phase) 7a) T.L. Cottrell & S. Paterson, *PrRoySoc* **213A**, 214-15 (1952) (An equation of state applicable to gases at high densities and high temperatures) 7b) J.E. Mayer & G. Careri, *JChemPhys* **20**, 1001 (1952) (An equation of state based on intermolecular potentials) 8) VanNostrand's *Dict* (1953), pp indicated in the text 8a) M.P. Murgai, *ProcNatInstSciIndia* **19**, 541-45 (1953) & *CA* **48**, 3691 (1954) (Application of Cottrell-Paterson equation of state to oxygen-deficient expls like TNT) 8b) A.K. Oppenheim, "Gasdynamic Analysis of the Development of Gaseous Detonation and Its Hydraulic Analogy", 4thSympCombstn (1953), p 472 (Hugoniot and Rankine-Hugoniot equations) 8c) M.A. Cook et al, *JPhysChem* **58**, 1114-24 (1954) & *CA* **49**, 2801 (1955) (A study of the equation of state for EDNA) 8d) F.J. Berry & M. Holt, "The Initial Propagation of Spherical Blast", Part I, "Polytropic Explosives", *ARE Rept* **6/54**, March 1954 [Also *ProcRoySoc* **224A**, 236 & 251 (1954)] 8e) J.O. Hirschfelder, C.F. Curtiss & R.B. Bird, "Molecular Theory of Gases and Liquids", Wiley, NY (1954), pp indicated in the text 8f) M. Holt, *Ibid*, Part III. "The General Properties of the Singularity at the Origin of Blast", *ARE Rept* **33/54**, Nov 1954 9) M.P. Murgai,

- ProcNatInstSciIndia **20**, 548-56(1954) & CA **49**, 11281(1955) (A modification of Corner equation of state) 9a) D. Malik, JFranklinInst **259**(3), 235-38(1955) (The equation of polytropic process for real gases)
- 9b) G.E. Duvall & B.J. Zwolinski, IEC **47**(6), 1182(1955) (Equation of state) 9c) R.H. Christian & F.L. Yarger, JChemPhys **23**, 2042-44(1955) (Equation of state of gases by shock wave measurements) 9d) J.O. Hirschfelder et al, "Generalized Equation of State for Both Gases and Liquids", Univ-WisconsinNavalResearchLabTechRept **TR WIS-00R-15**(1956)
- 9e) W. Fickett, W.W. Wood & Z.W. Salsburg, JChemPhys **27**, 1324-29(1957) (Investigation of the deton props of condensed expls with eqs of state based on intermolecular potentials)
- 10) Dunkle's Syllabus (1957-1958), 44-5, 54, 100, 127 & 165-66 (Rankine-Hugoniot equations; 181-87 (Equations of state which include among others the following: Jones & Miller, Lennard-Jones & Devonshire, Halford-Kistiakowsky-Wilson, Joffe & its modification by Su & Chang, Taylor, Kihara & Hikita, Travers, Cook, Kistiakowsky-Wilson-Brinkley and Polytropic equations); 194 (Landau-Stanyukovich and Hirschfelder et al equations of state 11) J.F. Roth, Explosivstoffe **1958**, 50 (Abel'sche Zustandsgleichung für die Detonation) 12) Cook (1958), 37 (General equation of state); 62-3 [Halford-Kistiakowsky-Wilson-Brinkley equation of state, (listed as K-H-W-B equation of state)]; 63 (Cook equation of state, using covolume approximation); 63-4 (Other covolume equations of state); 65 (Jones, Jones-Miller and Lennard-Jones equations of state); 66 (Cortrell-Paterson equation of state) 12a₁) W. Fickett & W.W. Wood, Physics of Fluids **1**, 528(1958) (A Detonation-Product Equation of State Observed from Hydrodynamic Data) 12a) Baum, Stanyukovich & Shekhter(1959), 246-59 (Derivation of Landau-Stanyukovich equation of state) 12b) Zel'dovich & Kompaneetz (1960), 223-46 (A refined analysis of the equation of state of the explosion products produced on deton of condensed explosives)
- 13) Dunkle's Syllabus (1960-1961), p 15d (Addnl information on Virial equation of state); p 15d (Macleod & Dieterici equations of state) 13a) 8thSympCombstn(1962) - papers and pages are indicated in the text 14) 10thSympCombstn(1964) - papers and pages are indicated in the text 14a) J.W. Enig & F.J. Petrone, "An Equation of State and Derived Shock Initiation Criticality Conditions for Liquid Explosives", 4thONRSympDeton(1965), p 395 and PhysFluids **9**, 398(1966) 14b) J.S. Robinson, Molecular Physics **7**, 349(1964) (An Equation of State of Gases at High Temperatures & Densities) 15) 4thONRSympDeton (1965) - papers and pages are indicated in the text 15a₁) I.C. Skidmore & S. Hart, "The Equation of State of Detonation Products Behind Overdriven Detonation Waves in Composition B", pp 47-51 in the 4thONRSympDeton(1965) (Gives in Appendix, p 65 a Modified Wilkins Equation of State) 15a₂) J.W.S. Allan & B.D. Lambourn, "An Equation of State of Detonation Products at Pressures Below 30 Kilobars", pp 52-66 in the 4thONRSympDeton(1965) 15a) N.L. Coleburn & T.P. Liddiard, Jr, JChemPhys **44**, 1929-36(1966) (Hugoniot equations of state of several unreacted explosives) 16) 11thSympCombstn(1967) - no papers on Equations of State were found 17) C.G. Dunkle, Silver Spring, Md; private communication, Jan 1968 18) W. Fickett, Los Alamos Scientific Laboratory, Los Alamos, New Mexico; private communication August 29, 1968
- Additional Refs:* A₁) A. Wohl, ZPhysikChem **87**, 1(1914); Ibid **99**, 207, 226 & 234(1921) (Equation of state) A₂) R. Plank, Forsch-GebieteIngenieurw **7**, 161(1936) (Virial equation of state) (See also Ref 2a, p 540, footnote 2) A₃) J.O. Hirschfelder et al, "Thermochemistry and the Equation of State of the Propellant Gases", OSRD Rept **547**, OEMsr-51, Div 1 Rept **A-48**, Carnegie Institute of Washington, DC, 22 Apr 1942. Progress Rept **A-116**, an extension and revision of **A-48**(1942) A₄) S.H. Maron & D. Turnbull, JACS **64**, 2195(1942) (A generalized equation of state) A₅) D.B. Macleod, TrFaradSoc **40**, 439-47(1944) (Equation of state) A₆) W.F. Rush & B.W. Gamson,

- IEC **41**, 78-81 (1949) (Equation of state. Generalized correlation applicable to all phases) B) S. Paterson & J. Davidson, JChemPhys **22**, 150 (1954) & CA **48**, 4911 (1954) [Cottrell-Paterson equation of state (see item d, above) was applied to various expls covering a wide range of loading d and reaction energy. The calcd velocities agreed well with exception of expls of low reaction heat at low loading d] C) T. Kihara & T. Kikita, 4thSympCombstn (1953), 458-64 & CA **49**, 6608 (1955) (Equation of state for hot dense gases and molecular theory of detonation) D) M.P. Murgai, JChemPhys **24**, 635 (1956) & CA **50**, 9078 (1956) (Corner equation of state, listed here as item c, was extended to the more extreme regions of pressure obtd in the deton of condensed expls) E) R.D. Cowan & W. Fickett, JChemPhys **24**, 932-39 (1956) & CA **50**, 11017 (1956) (Calculation of the Detonation Properties of Solid Explosives with the Kistiakowsky-Wilson Equation of State) F) C.J. Pings & B.H. Sage, IEC **49**, 1315-28 (1957) (Equations of state) F₁) L.V. Al'tshuler, et al, ZhEksp i TeoretFiz **34**, 606 (1958) (The technique described in item X₂ for detg shock properties of inert solids) G) J.O. Hirschfelder et al, IEC **50**, 375-85 (March 1958) (Generalized equation of state for gases and liquids) H) W. Fickett & W.W. Wood, The Physics of Fluids **1**(6), 528-34 (Nov-Dec 1958) (Detonation-product equations of state, known as "constant- β " and "constant- γ ", obtained from hydrodynamic data) I) J.J. Erpenbeck & D.G. Miller, IEC **51**, 329-31 (March 1959) (Semiempirical vapor pressure relation based on Dieterici's equation of state) J) K.A. Kobe & P.S. Murti, IEC **51**, 332 (March 1959) (Ideal critical volumes for generalized correlations) (Application to the Macleod equation of state) K₁) S. Katz et al, JApplPhys **10**, 568-76 (April 1959) (Hugoniot equation of state of aluminum and steel) K₂) S.J. Jacobs, JAmRocketSoc **30**, 151 (1960) (Review of semi-empirical equations of state) K₃) C.L. Mader, "Detonation Performance Calculations Using the Kistiakowsky-Wilson Equation of State", LASL Rept **LA-2613** (1961) L) M.M. Kuznetsov, ZhFizKhim **35**, 1430-34 (1961) & CA **55**, 24011 (1961) (Equation of state of the products in RDX detonation) M₁) W. Fickett, "Detonation Properties of Condensed Explosives Calculated with an Equation of State Based on Intermolecular Potentials", Los Alamos Scientific Laboratory Report **LA-2712** (1962), Los Alamos, New Mexico, pp 9-10 (Model of von Neumann-Zel'dovich), pp 153-66 [Comparison of KW (Kistiakowsky-Wilson) equation of state with those of LJD (Lennard-Jones-Devonshire) and Constant- β] M₂) C.L. Mader, "The Hydrodynamic Hot Spot and Shock Initiation of Homogeneous Explosives", LASL Rept **LA-2703** (1962) & PhysFluids **6**, 375 (1963) N) C.L. Mader, "Detonation Properties of Condensed Explosives Using Becker-Kistiakowsky-Wilson Equation of State", LASL Rept **LA-2900** (1963) O) M. Lutzky, "The Flow Field Behind a Spherical Detonation in TNT Using the Landau-Stanyukovich Equation of State for Detonation Products", USNavalOrdnanceLaboratory, White Oak, Md, **NOLTR 64-40** (1964) (The equation discussed in Rept is the one modified by Zel'dovich & Kompaneets and is referred to by Lutzky as "LSZK Equation of State") O₁) M.L. Wilkins, Univ of Calif, LawrenceRadLab, Livermore, Calif, Rept **UCRL-7797** (1964) P) H. Hurwitz, "Calculation of the Detonation Parameters With the Ruby Code", **NOLTR 63-205** (1965) (Use of modified Kistiakowsky-Wilson equation of state for computation of detonation parameters for TNT, PETN & RDX) Q) E.L. Lee & H.C. Hornig, "Equation of State of Detonation Product Gases", 12thSympCombstn (1968)(Pub 1969), pp 493-99 R) S.J. Jacobs, "On the Equation of State for Detonation Products at High Density", Ibid, pp 501-10 S) S.R. Brinkley, Jr, "Temperature Explicit Equation of State of the Products of Condensed Explosives", Ibid, Paper No 49, p 90 (Abstracts only)

Detonation (and Explosion), Expanding-Jet Theory of Jones. See Detonation (and Explosion), Nozzle Theory of Jones

Detonation (and Explosion), Experimental Data Interpretation of. It is not always easy to interpret experimental data and to correlate it with calculated data. Difficulties in the interpretation of experimental data on detonation and explosion were, accordg to Dunkle (Ref), well illustrated by the problems encountered in the analysis and interpretation of shaped charge data. A preliminary search of the literature produced over 2000 IBM cards, each carrying a brief abstract. In the initial stages of an Ordnance contract, Arthur D. Little, Inc carried the compilation a step beyond abstracting. Each of 11 parameters affecting shaped charge performance was considered separately, and tables of data were so arranged as to show the effects of varying each parameter along with certain others. The object was to show whether the most important data tended to confirm or disprove existing theories, reveal the gaps in current knowledge where further research was needed, and guide the design engineer in the improvement of end items. T.C. Poulter and B.M. Caldwell made an informal estimate that to test experimentally three values of each variable in all possible combinations of these variables, with only a single shot for each combination, would require more than six million tests. The need for statistical treatment was obvious (Ref 1)

As noted by Duff (Ref 2, p 199), equations of state had been developed which could match the experimental data as well as required for certain applications. Another class of equations of state resulted from attempts to describe the detonation products on the basis of first principles. While the two classes of work are motivated by different goals, and should not be confused with each other, both approaches should lead to the same final answer

Refs: 1) Dunkle's Syllabus (1957-1958), pp 341 & 375 2) R.E. Duff, "Summary of Papers on Condensed Phase Detonation", in 4thONRSympDeton(1965), pp 198-201 with comments by J. Hershkowitz & R. Cheret and 11 refs) 3) C.G. Dunkle, Silver Spring, Md; private communication, January 1968

Section 4

DETONATION (AND EXPLOSION), EXPERIMENTAL PROCEDURES. It was stated in the previous item that "It is not always easy to interpret experimental data and to correlate it with calculated data", and to this may be added the following probable reasons: 1) Calculations are not always exact on account of many assumptions and 2) Experimental procedures do not exactly interpret the phenomena, as for example in case of brisance, power, etc. There are usually several tests for the same phenomenon and when expressed in percentage of a "standard" explosive such as TNT, there is always a difference between the values given by each test. If we compare the values given in Table 1, pp B266 to B295 in Vol 2 of Encycl for "brisance" as determined by various methods, such as ST (Sand Test), CCCT (Copper Cylinder Compression Test), PCT (Plate Cutting Test) and PDT (Plate Denting Test), there are always differences between the values for the same explosive. For example "brisance" for RDX (p B270), expressed as percentage of TNT, is 140 by ST, 144 by CCCT, 125 by PCT and 135-141 by PDT. As we do not know which of these values to take, we think that the best way is to average them, which gives 137%. The same reasoning applies to "power" which for RDX is 170 by TT (Trauzl Test) and 150 by BMT (Ballistic Mortar Test), which gives an average value of 160%

Even if the tests are not exact, they are, nevertheless, helpful for comparing their results with calculated values, which might also be not exact

We are briefly describing here the procedures which were not discussed in Vols 1, 2 & 3 of Encycl. Some tests are given under individual items, such as "Detonation (and Explosion) by Influence"; "Detonation (and Explosion), Pressure of"; "Detonation (and Explosion), Temperature of"; "Detonation (and Explosion), Velocity of", while others are listed under Refs at the end of this item on Experimental Procedures

Following tests on Detonation, Explosion,

Deflagration and Combustion as well as on Detonators, Primers, etc are either listed giving refs, or briefly described in Vols 1, 2 & 3 of Encyclopedia:

Abel Test. See Vol 1, p A2

Aberdeen Chronograph Method. See Vol 3, p C308-R under CHRONOGRAPHS

Ability to Propagate Detonation; Transmission of Detonation or Extent of Propagation of Explosion. See Vol 1, p VII

Aptitude á l'inflammation, Essai. Fr "Capability to Inflammation Test". See under Combustion Tests in Vol 1, p X

Armor Plate Impact Test (Shell Impact Test). See Vol 1, p VII

Available Energy or Maximum Available Work Potential Tests. Cook (1958), pp 36-7 & 265-73 gives its definition and states that it can be approximately determined either by Ballistic Mortar or by Trauzl Block Tests. These tests are generally used for measuring power and strength of expls. Cook discusses on p 371 the reliability of these two methods for determination of available energy

Ballistic Mortar Test (BMT). See Vol 1, p VII and Vol 2, p B6-R. The BMT values for many expls are given on Table 1, pp B266 to B295 of Vol 2

Ballistic Pendulum Chronograph. See Vol 2, p B6-R

Ballistic Pendulum Test (BPT). See Vol 1, pp VII-VIII and Vol 2, p B6-R. The BPT values for some expls are given in Vol 2, pp B264 to B295

Barrier Tests. See Refs 50a & 65

Behavior Toward Heat Tests. See Vol 1, p VIII

Bichel Bomb or Bichel Pressure Gage. See Vol 1, p VIII and Vol 3, pp C331 & C332 under Closed Bomb

Bichel Calorimetric Bomb. See Vol 2, p B111-R

Blast Effects in Air, Earth and Water. See Vol 2, pp B180 to B184

Blasting Caps and Detonators, Initiating Efficiency of. See under Initiating Efficiency Tests in Vol 1, p XVIII

Blasting Caps and Detonators, Tests of. See Vol 1 under Esop's Test, p XI; Grotta's Test, p XV and Nail Test, p XIX. Some tests are described in this Volume under DETONATORS, etc

Blast Measurements. See "Blast Meters" in Vol 2, p B214-R and in Ref 82a, p 8

Blast Meters. See Vol 2, p B214-R

Bomb Drop Tests. See Vol 1, p VIII

Booster Sensitivity Test. See Vol 1, p VIII and Vol 2, p B247-L

Boulangé, Le; Chronograph Method. See Vol 3, p C307-R under CHRONOGRAPHS

Brisance or Shattering Effect Tests. See Vol 1, pp VIII-IX and Vol 2, pp B299-B300

Bulk Modulus and Bulk Compressibility Tests. See Vol 1, p IX and Vol 2, p B323

Bullet Impact Sensitiveness Test or Rifle Bullet Test. See Vol 1, p IX and in Vol 2, pp B332-B334 under Bullet Tests (See also Ref 55b for the test conducted at LASL)

Bullet Jump Test. See Vol 2, p B332-R under Bullet Tests

Bullet Penetration Test and Bullet Pull Test. See Vol 2, p B334-R under Bullet Tests

Bullet Stripping Test. See Vol 2, p B334-R

Bullet Tracer Test. See Vol 2, p B334-R

Bureau of Mines (BM) Impact Test. See under IMPACT SENSITIVITY TESTS

Burning Rate Determinations. See Vol 2, pp B349-R to B350-R under "Burning and Burning Characteristics of Propellants, Experimental Procedures". Descriptions and drawings of "closed vessels" and "strand burning apparatus" are given in Vol 3, pp C333-C336

Burning Tests, which include "Capability to Ignite (Inflame) and Burn", "Duration of Burning", etc are listed in Vol 1, p IX

Calorimetric Tests for Explosives, Propellants and Pyrotechnic Compositions. See Vol 1, p IX and Vol 2, pp C10-L to C12-R under Calorimeter, etc; also in this Vol under DETONATION (EXPLOSION, DEFLAGRATION, COMBUSTION AND FORMATION), HEATS OF

Camera (or Solenoid) Chronograph Method. See Vol 3, p C308-R under CHRONOGRAPHS

CAMERAS, HIGH-SPEED, PHOTOGRAPHIC for Use in Ordnance Testing. See Vol 2, pp C13-L to C19-R incl

Capability to Inflame Test. Fr test called "Épreuve de sensibilité à l'inflammation" is described by L. Médard in MP 33, 344 (1951)

Card Gap Test. See Refs 40 & 58 and also under GAP TESTS

Cathode-Ray Oscillograph Photography. See Vol 2, p C13-R under CAMERAS

Cavity Charge Performance. See Shaped (or Hollow) Charge Efficiency in Vol 1, p XXIII

Chalon Test is listed in Vol 1, p IX and briefly described in Vol 3, p C493-L

Chronographic Methods. See Vol 3, pp C304-R to C319-R

Chronophotography Method. See Vol 3, p C319-L

Closed Bomb (or Vessel) Tests. See Vol 1, p IX and Vol 3, p C330-L to C345-R

Closed Pit (or Chamber) Test and Other Fragmentation Tests. See Vol 3, pp C345-R to C351-L

Coal Mining Explosives, Testing for Permissibility. See Vol 3, pp C368-R to C378-L

Coefficient de self-excitation (CSE). Fr test for sympathetic detonation. See Vol 3, p C390-L

Coefficient d'utilisation pratique (CUP or cup). Fr test similar to Trauzl Block Test. See Vol 1, pp IX-X and Vol 3, p C390

Coefficient de vivacité des poudres. Fr test for determination of "quickness" of proplnts. See Vol 3, pp C390-R to C391-L

Combustion Tests are listed in Vol 1, p X. See also under Burning Tests

Compressibility of Explosives and of Propellants, Tests. See Vol 3, p C491

Compression Tests are listed in Vol 1, p X. The tests used for determination of brisance are described in Vol 3, pp C492-L to C494-R

Concrete Block Test. Fr test similar to Trauzl test, but using concrete instead of lead block. See Vol 3, p C495-L

Continuous Film Movement Camera. See Vol 2, p C14-L

Cook-off Tests. See Vol 1, p X and Vol 3, p C510-R

Cook's Pinset Method. See Vol 3, p C315-R and diagram on p C316 under CHRONOGRAPHS

Copper Cylinder Compression Test (CCCT) or Kast's Crusher Test is described in Vol 3,

p C493. The CCCT values for various expls are given in Vol 2, Table 1, pp B266 to B295

Copper Plate Denting Test. See Vol 1, p XIX under "Plate Denting Tests"

Counter Chronograph Method. See Vol 3, p C309-R under CHRONOGRAPHS

Cratering Effect Tests. See Vol 3, p C554

Crusher (or Compression) Tests. See Vol 3, pp C492-L to C494-R

Dautriche Method. See Vol 3, p C311-R

Deflagration Temperature Test. See under Ignition (or Explosion) Temperature Test in Vol 1, p XVI

Deflagration (or Explosion) Temperature of. Determination of temperature developed on deflgrn or expln of permissible expls is discussed in Vol 3, pp C444-L to C450-L

Density Determinations. See Vol 3, pp D64-R to D84-L

Density of Fragments Determination. See Fragment Density Tests

Dent Tests. Same as Plate Denting Tests

Detonation by Influence or Sympathetic Detonation Tests. Several tests are listed in Vol 1, p X and their description is given in this Section under "Detonation (and Explosion) by Influence"

Detonation (and Explosion) Pressure, Determination of. A brief description is given in Vol 1, p XX and a more complete description is in Vol 3, pp C330-L to C345-R under "Closed Bomb (or Vessel) and Instruments for Measuring Pressures Developed by Explosives and Propellants". See also some Refs under Detonation (and Explosion), Pressure of

Detonation Rate Determination. Several

tests and refs are listed in Vol 1, p X and the tests like Dautriche, Mettegang, are described in Vols 2 & 3. Some tests are also described under "Detonation (and Explosion), Velocity of"

Detonation Temperature Determination. See under Ignition (or Explosion) Temperature in Vol 1, pp XVI-XVII

Detonation (and Explosion) Temperature of, Determination. See in Vol 3, pp C444-L to C450-L

Detonation Velocity Determination. See under Detonation Rate Determination

Direct Contact Detonation Sensitivity Test. See Ref 64

Distribution of Shell Fragment Masses. One ref is listed in Vol 1, p XI. See also under Fragmentation Test

Driving Plate Test. See Ref 66a

Drop Tests. See IMPACT SENSITIVITY OR SHOCK SENSITIVITY TESTS

Döppler Effect for Study of Detonations. See Refs 29a & 71 and Döppler Effect in this Vol

Drum Cameras Tests. See Vol 2, p C14-L under CAMERAS, ETC

Earth Cratering Tests. See Cratering Effect Tests in Vol 3, p C554

Electrical Conductivity in Detonation Products. See Ref 72

Electrical Probe Technique. See Ref 75

Electrical Transducer Technique. See Ref 74

Épreuve des petits plombs (Fr for Small Lead Test). See Esop's Test and Vol 3, pp C492-93

Erosion of Gun Barrels. Several refs are listed in Vol 1, p XI

Esop's Test for Efficiency of Detonators. See Vol 1, p XI

Essai au choc du mouton (Shock Test by Ram). Fr impact test listed together with refs in Vol 1, p XVII under Impact Sensitivity

Explosion Temperature Test. See Ignition (or Explosion) Temperature Test in Vol 1 of Encycl, p XVI

Explosive Train Test. See in Ref 81

Extent of Propagation of Detonation (and Explosion). See Ability to Propagate Detonation in Vol 1, p VII

Exudation (or Sweating) Tests. See Vol 1, p XI

FI (Figure of Insensitiveness) Test. See Vol 1, p XII

Field Chronograph Test. See Vol 3, p C310-L under CHRONOGRAPHS

Fire Resistance or Fire Tests are listed in Vol 1, p XII

Flame Test. See Vol 1, p XII

Flash Photography Tests. See Vol 2, p C14 under CAMERAS

Flash Point Test. See Vol 1, p XII

Four Cartridge Test. See Vol 1, p XII and in this Section under Detonation (and Explosion) by Influence

Fragmentation Tests or Fragmentation Efficiency Tests (FET). See Vol 1, p XII & PATR 1740(1958). Also "Closed Pit", "Open Pit" & "Panel Pit" Methods, "Low Panel" & "High Panel" Tests and "Silhouette" Test in Vol 3, pp C345 to C350-R. The FET values are listed for some expls in Vol 2, pp B266 to B295. See also Ref 82a, p 7

Fragment Density Tests. See Vol 1, p XII and German Fragment Density Test in Vol 3,

p C350-R. Also see "Density of Fragments Test" in Vol 3, p C84-L

Fragment Gun Test (FGT). See Vol 1, p XII. The FGT values for several expls are given in Vol 2, pp B266 to B295

Fragment Velocity Measurements. See Vol 1, p XIII; Vol 3, p C350-L; PATR 1740(1958) and Refs 55e; 82a, p8 & 82b

Framing Camera. See Vol 2, p C14-R under CAMERAS

Freezing Tests for Dynamites. See Vol 1, p XIII

Friction Sensitivity Tests. See Vol 1, pp XIII & XIV

Fuse Test. See Test a) in Vol 1, pp XXII-XXIII under "SENSITIVITY TO FLAME, SPARKS, ELECTROSTATIC DISCHARGES, ETC"

Fuze Tests. See under DETONATORS, etc, Section 9, Physical Testing of Fuzes in this Vol

Galleries for Testing Permissible Explosives. Several refs are given in Vol 1, p XIV. European galleries and US galleries at Bruceton, Pa are described under "Coal Mining Explosives, Testing for Permissibility", Vol 3, pp C370-R to C377-L. Gallery used in Dortmund, Germany during WWII is briefly described as "Versuchstrecke, Dortmund-Derne" in PATR 2510(1958), p Ger 215-R

GAP TESTS. A general name for several tests used for determination of sympathetic detonation. They include Bur of Mines tests "Halved-Cartridge Method" (Vol 1, p XIV), French "Coefficient de self-excitation" (Vol 3, p C390-R), "Whole-Cartridge Method" (Vol 1, p XIV) and several tests described in this section under "Detonation (and Explosion) by Influence. These include: "Card Gap Test", "Four Cartridge Test", "Shock-Pass-Heat-Filter (SPHF) Plate Test",

'Three-Legged Table Test', and 'Wax-Gap Test'. Gap Tests are also described in Refs 2, 36, 38a, 40, 47a, 48, 50, 52, 54, 55b, 56a, 58, 59, 60, 62, 63, 65, 66, 68 and 80

Granulation Tests. See Vol 1, p XV

Grotta's Test for Detonators. See Vol 1, p XV

Halved Cartridge Gap Test. See under GAP TESTS

Heat of Combustion (Q_C or H_C), Heat of Explosion (Q_e or H_e), Heat of Detonation (Q_d or H_d) and Heat of Formation (Q_f or H_f) Determination. See under Calorimeter in Vol 2, pp C10-L to C12-R and in this Vol under DETONATION (EXPLOSION, DEFLAGRATION, COMBUSTION AND FORMATION), HEATS OF

Heat Tests. A list of various tests and refs is given in Vol 1, p XV. Abel Test is briefly described in Vol 1, p A2

100° Heat Test. See Vol 1, p XV

120° and 134.5° Heat Tests. See Vol 1, pp XV-XVI

Hemispherical Iron Disc Test. See test b) in Vol 1, p XXIII under "SENSITIVITY TO FLAME, HEAT", etc

Hess' Crusher Test or Lead Block Compression Test (LBCT). See Vol 3, p C492. The LBCT values for various expls are listed in Vol 2, Table 1, pp B266 to B295

High-Panel Fragmentation Test. See Vol 3, p C350-R

High-Speed Radiography. See Vol 1, p XVI and in Vol 2, under CAMERAS, Test JJ, p C17-R

Hollow Charge (or Munroe-Neumann Effect) Efficiency Tests. See Shaped Charge or Hollow Charge Efficiency in Vol 1, p XXIII

Hopkinson Pressure Bar. See Vol 1, p XVI

Hygroscopicity Tests. See Vol 1, p XVI

Ignition (or Explosion) Temperature Tests, also called *Deflagration Temperature, Detonation Temperature and Flash Point Tests.* See Vol 1, pp XVI-XVII

Ignition Time and Temperature of Ignition Relationship. See Vol 1, p XVII

Image Converter and Image Dissector Cameras. See Vol 2, p C14-R under CAMERAS

Impact-Friction Pendulum Test. See Vol 1, p XVII and p A354, Footnote

IMPACT SENSITIVITY OR SHOCK SENSITIVITY TESTS (Drop Weight or Falling Weight Tests). A list of various tests with refs is given in Vol 1, p XVII. Brief descriptions of US Bureau of Mines (BM) Apparatus and of Picatinny Arsenal (PA) Apparatus are also given on p XVII. British test called Figure of Insensitiveness (FI) is described on p XII (See also Refs 36, 38d, 41, 42, 53, 55b, 57, 79, 81 & 82a

Index of Inflammability. See Vol 1, p XVII

Influence Tests. Same as Detonation by Influence Tests

Initial (or Muzzle) Velocity of Projectiles. It is determined by Chronographs as described in Vol 2, pp C306-L to C310-R

Initiating Efficiency (or Strength) of Detonators by the Miniature Cartridge Test. See Vol 1, p XVII and R.L. Grant & J.E. Tiffany, "Detonators: Initiating Efficiency by the Miniature-Cartridge Test", USBurMines-TechPaper 677(1945)

INITIATING EFFICIENCY (OR STRENGTH) OF INITIATING DEVICES DETERMINATIONS. A list with refs is given in Vol 1, p XVIII

Initiating Efficiency (or Strength) of Primary Explosives by Sand Test. See Vol 1, pp XVIII & XXI

Initiation by Low Velocity Impact. See Ref 66a

Initiation by Shock. See Ref 59

Interferometer Camera. See Vol 2, p C14-R

Intermediate Rate Camera or Medium Repetition Rate Camera. See Vol 2, p C14-R

Intermittent Film Movement Camera and Intermittent Light Source Cameras. See Vol 2, p C15-L

International 75° Test. See Vol 1, p XVIII

Kast Brisance Meter or Kast's Crusher Test. Same as Copper Cylinder Compression Test (CCCT)

Kerr Cell Test. See Vol 2, pp C15-L & C15-R under CAMERAS

KI-Teat Test or KI-Starch Test. Same as Abel Test

Kraftzahl (KZ) Probe. See Vol 1, p XVIII

Large Scale Gap Test (LSGT). See Refs 48 & 56a

Lead Block Compression Test (LBCT). Same as Brisance Meter of Hess Test described in Vol 3, p C492 & C493

Lead Block Expansion Test (LBET). Same as Trauzl Test described in Vol 1, p XXV

Lead Plate Test. See under Plate Tests, Vol 1, p XX

Low Panel Fragmentation Test. See Vol 3, p C350-R

Machine Gun Chronograph. See Vol 3, p C310-R

Maximum Available Work Potential Determination. See Available Energy or Maximum Available Work Potential in this Section

Maximum Pressure of Explosion. See Vol 1, p XIX

Medium Repetition Rate Camera. Same as Intermediate Rate Camera

Mettegang Chronograph. See Vol 3, pp C312 & C313

Microwave Technique. See Refs 38b & 71

Microwave Technique Chronograph. See Vol 3, p C315-R and the diagram on p C316

Miniature Cartridge Test. See under "Initiating Efficiency (or Strength) of Detonators by the Miniature Cartridge Test"

Miniature Charge Techniques for Determination of Detonation Velocity. See Vol 1, p XIX

Mortar Test. See Vol 1, p XIX. Compare with Ballistic Mortar Test

Munroe-Neumann Effect Tests, also known as Hollow Charge (or Shaped Charge) Effect Tests. See Shaped Charge or Hollow Charge Efficiency in Vol 1, p XXIII

Muzzle Velocity Determination. See Initial (or Muzzle) Velocity of Projectiles

Nail Test for Detonators. See Vol 1, p XIX

Open Pit Fragmentation Test. See Vol 3, p C346-R

Optical Method for Testing Caps. See Vol 1, p XIX

Oscillograph Camera. See Vol 2, p C15-R

Panel Fragmentation Tests. See p C349-L

Pendulum, Ballistic Test. See Ballistic Pendulum Test

Pendulum Friction Device Test. See under Friction Sensitivity Tests

Percussive Force of an Explosive Determination. See Vol 1, p XIX

Permissibility of Coal Mining Explosives, Tests for. See under Galleries for Testing Permissible Explosives

Photoelectric Cell Camera. See Vol 2, p C15-R under CAMERAS

Pin Chronograph, Test with. See Vol 3, p C312-R

Pinset Method of Cook. See Vol 3, p C315-R and diagram on p C316 from Cook's book (Ref 36, p 29)

Plate Cutting Tests (PCT). See under Plate Tests in Vol 1, p XX. The PCT values for various expls are given in Table 1, pp B266 to B295 under BRISANCE

Plate Denting Tests (PDT). See Vol 1, p XIX and under Plate Tests on p XX. The PDT values for various expls are given in Table 1, pp B266 to B295 of Vol 2 under BRISANCE

Power of Explosives, Determination. The tests and refs are listed in Vol 1, p XX. The tests most used are Ballistic Mortar and Trauzl Block Tests. See also Ballistic Pendulum, Coefficient d'utilisation pratique, Cratering Effect, Kraftzahl, Mortar Test and Quinan Test. Cook (1958), pp 36-7 claims that Ballistic Mortar and Trauzl Block Tests were the only satisfactory methods for determination of "Available Energy" or "Maximum Available Work Potential". He also states on p 271 that it is very questionable that Trauzl Test measures "power" (the rate of doing work), but it is rather a measure of "relative available energy". About Ballistic Mortar it is stated that it "yields available energy - -"

Pressure Bar of Hopkinson. See Hopkinson Pressure Bar

Pressure of Detonation, Determination of. See under Detonation (and Explosion) Pressures of and their Measurements

Pressure of Gases Developed on Combustion or Deflagration of Propellants or Explosives. See Vol 1, p XX and Vol 2, pp C425ff & D38-L

Pressure of Gases Developed on Explosion or Detonation. See Vol 1, p XX and under Detonation (and Explosion), Pressures of and Their Measurements

Pressure Sensing Probes for Detecting Shock Waves. See Ref 39a

Primary Explosives, Initiating Efficiency of. See under Initiating Efficiency of Primary Explosives, etc in Vol 1, p XVIII

Probe Methods. See Electrical Probe Technique in Ref 75 and Probe Methods of Ionization Determination in Ref 36, p 144 and diagrams 7.1 & 7.2

Product Characteristic of Berthelot (Produit caractéristique de Berthelot) Determination. See Berthelot's Characteristic Product in Vol 2, p B105-L

Propagation of Detonation, Ability of. See Ability to Propagate Detonation in Vol 1, p VII

Propagation Test. See Vol 1, p XXI

Propulsive Force, Determination. See Vol 1, p XXI

Quickness of Burning of Propellants. See Vol 1, p XXI

Quinan Compression Test. See Vol 3, pp C493-R & C494-L

Radiation Measurements in Reaction Zone of Condensed Explosives. See Ref 73

Radiography of High-Speed Events. See X-Ray High-Speed Photography in Vol 2, p C17-R under CAMERAS

Rate of Detonation Determination. See Detonation Rate (or Velocity) Determinations

Red Iron Test. See Vol 1, p XXIII, test c) under "SENSITIVITY TO FLAME, HEAT", etc

Reflected Light Photography. See Vol 2, p C15-R under CAMERAS

Reprise d'humidité, Essai (Taking up Moisture Test). A French Humidity Test described by L. Médard, MP 33, 325-27 (1951)

Resistance to Heat Test. Fr test called "Épreuve de la résistance à la chaleur". See Vol 1, p XXI

Rifle Bullet Test. See Bullet Impact Sensitiveness Test

Rotating Disc Chronograph. See Vol 3, p C310-R

Rotating Drum, Rotating Lens Ring and Rotating Prism Cameras are listed together with refs in Vol 2, p C15-R

Rotter Impact Test. British test designed by Dr Rotter of Research Dept, Woolwich, England is listed with two refs in Vol 1, p XVII under Impact Sensitivity Tests. The value obtd by this test is called FI (Figure of Insensitiveness) and is defined more fully in Vol 1, p XII

Sand Test (ST) or Sand Crushing Test. See Vol 1, pp XXI-XXII. The ST values for various expls are listed in Vol 2, Table 1, pp B266 to B295

Sand Test for Primary Explosives. See Initiating Efficiency (or Strength) of Primary Explosives by Sand Test in Vol 1, p XVIII

Schlieren Method Camera. See Vol 2, pp C15-R & C16-L under CAMERAS

Sensitivity (Sensitiveness) of Explosives, Propellants and Pyrotechnic Compositions,

Tests. A list of tests without description is given in Vol 1, p XXII. Most of them are briefly described under corresponding names in Vols 1, 2 & 3 of Encycl

Sensitivity to Flame, Heat, Sparks, Electrostatic Discharges, etc. Several tests are described in Vol 1, pp XXII & XXIII and some are just listed together with their refs

Sensitivity to Initiation by Primary Explosives. See Vol 1, p XXIII and in Section 9, under DETONATORS, ETC

Shadow (or Silhouette) Camera Method. See Vol 2, p C16-L, under CAMERAS

Shaped Charge or Hollow Charge Efficiency (Cavity Charge Performance or Munroe-Neumann Effect) Test. See Vol 1, p XXIII

Shell Impact Sensitivity Test. See Armor Plate Impact Test in Vol 1, p VII

Shock-Pass-Heat-Filter (SPHF) Sensitivity Test. This test developed by Cook et al is described in Ref 36, p 83 and in Ref 40

Shock Pressure Required to Initiate an Acceptor. See Ref 52

Shooting Tests. See Refs 50a & 65 in this Section

Silhouette Camera Method. Same as Shadow Camera Method

Silhouette Fragmentation Test. See Vol 3, p C350-R

Silvered Vessel (or Waltham Abbey Silvered Vessel) Test. See Vol 1, p XXIV

Skid Test is described by A. Popolato (Our Ref 55b)

Small Block (or Small Lead Block) Compression Test for Detonators (Épreuve des petits plombs, in Fr). See "Compression Test with Small Lead Block" in Vol 3, pp C492-R to C493-L and also Esop's Test in Vol 1, p XI

- Small Lead Block Expansion Test for Detonators.* See bottom of p XXV in Vol 3 under Trauzl Test
- Small Scale Gap Test (SSGP).* See Refs 26, 47a & 80
- Small Scale Plate Test (SSPT).* See Ref 25
- Smear (Streak or Sweeping Image) Camera,* used for studies of deton phenomena is described in Vol 2, p C16 under CAMERAS
- Sound Test for Detonators.* See Vol 1, p XXIV
- Spark Photography.* See Vol 2, pp C16-R to C17-L under CAMERAS
- Speed Light Photography.* See Vol 2, p C17-L under CAMERAS
- Stability (Thermal) of Explosives and Propellants.* See under Heat Tests in Vol 1, p XV
- Stationary Film Camera.* See Vol 2, p C17-L
- Stauchprobe.* Ger name for Crusher Test
- Stauchprobe nach Hess or Lead Block Compression Test (LBCT).* See Vol 3, p C492-L
- Stauchprobe nach Kast or Copper Cylinder Compression Test (LCCT).* See Vol 3, p C493-L
- Steel Plate Cutting Test.* See Vol 1, p XX under Plate Tests
- Steel Plate Denting Test.* See Vol 1, p XIX under Plate Denting Tests
- Streak Camera.* Same as Smear or Sweeping Image Camera
- Strength of Detonators, Test.* See "Initiating Efficiency (or Strength) of Detonators by the Miniature Cartridge Test" in Vol 1, p XVIII
- Strength of Explosives, Test.* See Vol 1, p XXIV and under Power of Explosives Determination
- Stroboscopic Cameras.* See Vol 2, p C17-L & C17-R under CAMERAS
- Surveillance Tests.* See Vol 1, p XXIV
- Susan Test.* See Ref 67 in this section
- Sweeping Image Camera.* Same as Smear or Streak Camera
- Sympathetic Detonation Tests.* See under Detonation by Influence
- Taliani Test.* See Vol 1, pp XXIV-XXV and in Ref 79
- Temperature Developed on Detonation (or Explosion).* See Vol 1, p XXV and in the text of this Section under "Detonation (and Explosion), Temperature of"
- Testing Galleries.* See Galleries for Testing Permissible Explosives
- Thermal Induction Time Test.* See Ref 55b
- Thermal Stability Tests.* See Heat Tests
- Three-Legged Table Test.* See under Detonation (and Explosion) by Influence
- Time of Ignition (or Explosion) Tests at Constant Temperatures.* See Ignition (or Explosion), Time Tests in Vol 1, p XVII
- Transmission of Detonation (or Explosion) Through Air.* Same as Detonation (or Explosion) by Influence
- Transmission of Detonation Through Explosive Charges.* See Ability to Propagate Detonation in Vol 1, p VII
- Trauzl Test (TT); Trauzl Block Test; or Lead Block Expansion Test (LBET).* See Vol 1, pp XXV-XXVI. The TT values for various expls are listed in Vol 2, Table 1, pp B266 to B295

Vacuum Stability Test. See Vol 1, p XXVI

Vapor Pressures of Explosives, Determination. See Vol 1, p XXVI

Velocity of Detonation Determinations. See Detonation Velocity (or Rate), Determinations

Vitesse de détonation. Fr for Detonation Velocity

Vivacité des poudres (Fr). See Quickness of Burning of Propellants in Vol 1, p XXI

Volatility of Explosives. See Vol 1, p XXVI

Volume of Gases Evolved on Detonation (or Explosion), Determination. See Vol 1, p XXVI

Waltham Abbey Silvered Vessel Test. See Silvered Vessel Test in Vol 1, p XXIV

Wax Gap Test. See Vol 1, p XXVI and in the text of this Section, under "Detonation (and Explosion) by Influence

Whole Cartridge Test. See under "Detonation (and Explosion) by Influence

X-Ray High-Speed Photography or Radiography of High-Speed Events. See Vol 2, p C17-R under CAMERAS

References to Experimental Procedures (Not including Chemical Procedures)

1) Marshall 2(1917): Falling Weight Test (Lenze)(p 423); Friction Sensitivity Test (423); Sensitiveness to Detonation (429); Sensitiveness to Heat (434); Ignition Temperature (434); Heat of Explosion (440); Trauzl Test (469); Strength by Ballistic Pendulum (473); Velocity of Detonation by Dautriche Method (479); Brisance Meter of Hess (495)

1a) Colver(1918): Sand Test for Detonators (pp 554-60); Bichel Pressure Gauge (605-12); Heat of Combustion (614-16); Detonation Velocity by Mettegang Apparatus (622-28); Ditto, by Dautriche Method (628-38); Falling Weight Testing Machine (642-45); Brisance Meter (656-60); Trauzl Test (660-66); Ballistic Pendulum Test (666-70)

1b) Barnett(1919): Trauzl Test (pp 179-81); Ballistic Mortar Test (181-82); Ballistic Pendulum Test (182-84); Brisance Meter (184); Detonation Velocity by Mettegang Method (185-95); Pressure of Explosion by Copper Crusher Gauge (195-96); Heat of Explosion (197-200); Temperature of Explosion (200-01); Falling Weight Test (208-11)

1c) Naoúm, NG(1928): Abel Stability Test (pp 127-33); German Test (134-35); Sensitiveness of NG to Detonation (142-44); Propagation of Detonation and Velocity of Detonation (144-46); Volume of Gases Formed on Explosion (146-48); Heat of Explosion and Temperature of Explosion (148-50); Explosion Pressure (150-51); Energy Content and Work Performed (151-54); Trauzl Lead Block Test (154-56); Crusher Test (156-58)

2) Munroe & Tiffany(1931): Apparent Specific Gravity (pp 22-3); General Examination of Cartridges (23-24); Determination of Shaking Density (24); Exudation Tests, which include Forty-Degree Test and British Test (25-27); Freezing Tests (27-30); Tests for Rate of Burning (30-31); Fire-Resistance Tests, which include Fuse Test, Hemispherical Iron-Dish Test and Red-Hot Iron Test (31-32); Water-Resistance Test (32-34); Screening Tests (34-35); Storage Tests (35-36); US Bureau of Mines Ballistic Pendulum (40-46); DuPont Type Ballistic Mortar (46-49); Gallery No 1 of Bureau of Mines (49-57); Gallery No 8 and Gallery No 16 (58-59); Sensitiveness to Explosion by Influence, using Halved-Cartridge Gap Method (59-60); Determination of Detonation Rate by Mettegang Recorder and by Dautriche Method (60-67); Determination of Relative Length and Duration of Flame (67-71); Sensitiveness to Explosion by Direct Impact (pp 71-78 and Fig 25 on p 66); Sensitiveness to Explosion from Glancing Blow by Bureau of Mines Pendulum Friction Device (78-84); Determination of Pressure Developed on Explosion with Bichel Pressure Gauge (84-91); Determination of Gaseous Products of Explosives on Exploding using Bichel-Pressure Gauge and Cranshaw-Jones Apparatus (91-99);

Determination of Heat Liberated on Explosion with Calorimeter (99-104); Lead Block Expansion Test (Trauzl Test) (104-06); Compression Tests with Small Lead Blocks (106-08); Testing of Detonators, which include Sand Test and Nail Test (108-14); Water Resistance of Electric Detonators (114-15); Testing Burning (Safety) Fuse (115-18); Testing Detonating Fuse (118-19)

2a) Marshall 3 (1932): Friction Test (pp 125-28). Other tests are described in Vol 1 (See Ref 1)

2b) Vennin, Burlot & L  corch   (1932): Calorimetric Bombs of Berthelot-Vieille and Burlot-Malsallez (pp 60-62); Calorimeters of Landrieu-Malsallez and of Commission des Substances Explosifs (62-66); Determination of Volume of Gas Evolved on Explosion (68-70); Determination of Pressure of Gas (72-87); Determination of Detonation Velocity (158-61); Trauzl Test, French Modification (171-74); Cratering Test (Essai dans la terre) (184-85); Mortar Test (Essai au mortier   provette) (189); Lead Block Compression Test (  preuve des petits plombs) (190-92); Quinan Test (192-93); Sympathetic Detonation (Transmission de la d  tonation    distance) (203-10); Deflagration Point (211-12); Sensitivity to Friction (212-13); Sensitivity to Impact (213-15); Rifle Bullet Test (215-16); Hygroscopicity (233); Exudation (224); Chemical Stability (226 & 282); Tests for Permissible Explosives (Essais des Explosifs Antigrisouteux) (228-51); Density Determinations (253-55); Velocity of Projectiles by Chronograph Boulang  -Br  ger (255-60); Determination of Pressure Developed in Weapons (260-62); Measurement of Ballistic Strength of Small Arms by Ballistic Pendulum (269-72); and Ignition Point by Block Maquenne (280-81)

3) Stettbacher (1933): Brisance Determination by Compression of Small Cylinder and by Fragmentation Tests (pp 48-52); Detonation Velocity by Mettegang and by Dautriche Methods (54-59); Size and Duration of Flames Developed on Explosion (65-68); Volume and

Pressure of Gases Evolved on Explosion (69-81); Heat of Explosion or Combustion (81-85); Temperature of Explosion (85-94); Plate Punching and Plate Denting Tests (Durchschlags - und Strahlungsprobe) (361); Lead Block Expansion Test (Trauzl Test) (361-65); Lead Block Compression Test (Hess Test) and Copper Cylinder Compression Test (Kast Test) (365-68); Ballistic Pendulum and Ballistic Mortar Tests (368-70); Sensitivity to Friction (371-72); Impact Sensitivity Test (371-73); Deflagration Temperature (Verpuffungstemperatur) (373-75)

3a) L.V. Clark, IEC 25, 1388-90 (1933) (Description of Lead Block Compression Test, Fragmentation Test, Small Trauzl Test, Determination of Detonation Rate, Modified Gap Test and Ignition Temperature Test)

4) Pepin Lehalleur (1935): Assembly of Calorimeter Landrieu-Malsallez and Bomb of Burlot-Malsallez (p 44, Fig 5); Brisance Determination by Kast, Quinan and Chalon Methods (63-64); Trauzl Block Test (French Modification) (64-66); Mortar Test (  preuve de tir au mortier) (66-67); Ballistic Pendulum (67); Cratering Test (Essai dans la terre) (67-68); Deflagration Temperature (68); Lead Plate Test for Detonators (68-69); Sand Test (Essai au sable) (69); Nail Test (Essai au clou) (69); Tests for Electric Detonators (69-70); Tests for Fuses (Essais des m  ches) (70); Tests for Detonating Cords (Essais des cordeaux detonants) (70); Determination of Detonation Velocity (71-4); Sensitivity to Impact (Sensibilit   au choc) (74-5); Sensitivity to Friction (75-6); Sensitivity to Initiation (Sensibilit      l' amorce) (76); Pressure Measurements by Manometric Bomb, by Crusher Test and by Piezoelectric Manometer (79-97); Density Determination (99-100); Chronographs of Schulze and of Le Boulang   (101); Tests for Stability by Methods of Abel, Spica, Vieille at 110  C, German at 135   Bergmann-Junk, Su, Hansen-Grotannelli, Silvered Vessel and Taliani (107-09); Explosion Test (109-10)

4a) Beyling & Drekopf (1936): Detonation

Velocity by Dautriche Test (pp 12-23); Heats of Formation and of Explosion (33-41); Temperature of Explosion (41-8); Pressure of Explosion (49-58); Power by Trauzl Test (58-63); Brisance by Crusher Test (Stauchapparat) (64-5); Testing of Blasting Caps by Lead Plate Test (155-57); Testing of Blasting Caps by Pendulum Apparatus (157-59); Determination of Burning Time of Safety Fuses (163-65);

5) Reilly (1938): Tendency to Segregate (Caking) (p 65); Exudation (65-6); Inflammability (66); Ignition Temperature (66); Sensitivity to Shock and Friction (66-7); Lead Block Expansion Test (Trauzl Test) (67-8); Ballistic Pendulum Test (68); Brisance Meter of Kast (68); Rate of Detonation by Dautriche Method (68-69); Length and Duration of Flame (69); Testing of Detonators (69-70); Stability Tests, including Abel Heat Test, Zinc Iodide, Hoitsema Spica, Hess, Vieille, Horn-Seifert, Surveillance, Methyl Violet, Jensen and Simon-Thomas Tests (pp 70-80); also American Tests at 65.5-80.5°C, International 75° Test, German Test "Warmlagermethode 75°, Silvered Vessel, Taylor, German 132°, Bergman-Junk, Sy Method Meerscheidt-Hüllessem, Dutch, Brunswig, Will, Dupré, Mittasch, Obermüller, Brame, Chiaraviglio & Corbino, Taliani, Desmaroux, Marqueyrol, Angeli, Tomonari, Vacuum Stability and Haid, Becker & Dittmar Tests (pp 80-93)

6) Hayes (1938): Measurement of Grains (pp 28-29); Compression Test (29); Stability by KI-Starch Paper Test, 134.5°C Heat Test, 120°C Heat Test, 65.5°C Surveillance Test and Observation Test (29-30); Ballistic Test (30-31); Heat of Explosion at Constant Pressure (51-2); Volume of Gas (52-3); Heat of Explosion at Constant Volume (54-5); Potential (55); Temperature of Explosion (55-7); Pressure of Explosion (57-61); Heat of Explosion of Propellants (62-4); Ignition of Propellants (68-70); Mode and Rate of Burning (70-71); Velocity Measurements by Le Boulangé, Aberdeen, and Solenoid Chronographs (84-92); Pressure Measurements by Crusher and Piezoelectric Gages (92-6)

7) Davis, Vol 1 (1941): Determination of Detonation Velocity by Dautriche Method (pp 14-18); Impact or Drop Test (p 21); Ignition Temperature Test (21-22); Stability Tests (22); Power by Trauzl Method (24-5); Brisance Tests by Small Lead Blocks (25-6); Aluminum Plate and Lead Plate Tests for Detonators (26-7)

8) Davis, Vol 2 (1943): Sensitivity of NG (p 209); Stability Tests for NC, which include: KI-Starch Test at 65.5°, Methyl Violet Test at 134.5°C, Bergmann-Junk and Vacuum Tests (267-69); Testing of Detonators by Nail Test and by US Bureau of Mines Sand Test (421-24)

9) Meyer (1943): Heats of Explosion (pp 24-7); Explosion Point (27-8); Shock Sensitivity by Drop-Weight Apparatus (28-30); Sensitivity to Initiation (30-2); Velocity of Explosion by Mettegang Apparatus and by Dautriche Method (32-7); Measurement of Grain Dimensions (123-28); Compressibility of Grains (128-29); Initiation by Ignition (289-91); Initiation by Percussion (291-92); Explosion Flame Measurements (292-94); Initiation by Detonation (294-96); Testing of Detonators by Lead Plate (296-97); Heat of Explosion by the Bomb Calorimeter (371-73); Explosion Pressure (373-74); Trauzl Test (374-75); Hess Crusher Test (375-76); Ballistic Mortar and Pendulum Tests (376-77); Sand Test and Cratering Test (377-80)

10) Vivas, Feigenspan & Ladreda, Vol 4 (1944): Métodos y Aparatos para las Pruebas de Pólvoras y Explosivos y Determinación de sus Características (pp 62-120). These include: Determination of Detonation Velocity by Method of Mettegang and by Method of Dautriche; Heat of Explosion and Combustion, using Calorimetric Bomb of Burlot-Malsallez and Calorimeter Landrieu-Malsallez; Determination of Pressure of Gases Developed on Explosion using Manometric Apparatus of Sarrau & Vieille; Determination of Volume of Gases and Their Composition by Gasometer of Sarrau & Vieille and Analizador Sodeau; Determination of Pressure Developed on Explosion by Bichel Bomb; Determination

of Sensitivity to Impact using Drop-Weight Apparatus; Apparatus for Determination of Length and Duration of Flame; Determination of Strength of Explosives by Trauzl Test, by Mortar (Mortero probeta) and Cratering Effect; Brisance (Poder rompedor) by Formula of Kast; Testing of Primers and Detonators by Iron Plate Method

11) Kast-Metz (1944): Ignition Temperature of NC (pp 224-26); Stability of NC by Abel, Guttman, Spica, Methyl violet, Egerton, Thomas and Heat Tests at 132° & 135°C (227-35); also by Vieille, Will, Bergmann-Junk, Obermüller, Mittasch, Taliani and by Loss of Weight Tests (235-246); Silvered Vessel Test (247-48); Nauckhoff-Philip Method (248); Storage Tests at Various Temperatures (258-61); Tests for Smokeless Propellants: Ignition Temperature (306-07); Stability Tests, which include Abel, Guttman, Heat at 132°, Dutch, Vieille at 110°, Bergmann-Junk, Will, Obermüller, Taliani, Loss of Weight, Patard, Thomas and Berthelot & Gaudechon Tests (307-17); Silvered Vessel Test (317-18); Hansen, Metz, Storage, and Marquoyrol Tests (318-27); Ballistic Stability (327)

12) W.H. Rinckenbach & A.J. Clear, "Standard Laboratory Procedures for Sensitivity, Brisance and Stability of Explosives", PATR 1401 (1944) (Superseded by Ref 79)

12a) "Statistical Analysis for a New Procedure in Sensitivity Experiments", Princeton University Statistical Research Group, Report No 101.1R of the Applied Mathematics Panel, NDRC, July 1944

13) Pérez-Ara (1945): Determination of Heat of Explosion (Medición del calor desarrollado en explosión by means of Calorimetric Bombs of Berthelot (p 63), of Sarrau (64), of Noble & Abel (64), of Burlot-Malsallez (65), and of Bichel & Mettegang (66-9). Also are described Calorimeters of Landrieu-Malsallez and Gas Calorimeter (69-70); Determination of Temperature of Explosion (70-1); Determination of Ignition Temperature (72-3 & 108-

10); Determination of Pressure of Gases Evolved on Explosion by Count Rumford (73), by Manometer of Rodman (74), by Crusher Gage (Manómetro de aplastamiento) of Noble (74-6), by Rifle Medidor de Strange (76), by Registering Manometer of Bichel (Manómetro registrador de Bichel) (76-9), Registering Manometer "Crusher" of Vieille & Sarrau used in France by the Commission des Substances Explosifs (79-84), by Manometer of Petavel (pp 84-5), by Piezoelectric Manometers, among them German apparatus called "Zeiss Icon" (85-90); Determination of Volume of Gases Developed on Explosion by means of Gasometer of Sarrau & Vieille (91-2); Determination of Detonation Velocity, using Chronograph Le Boulangé (93-5), Chronograph of Mettegang (95-7), Accelerograph and Accelerometer of Marcel Deprez (97-8) and Dautriche Method (98-100); Determination of Sensitivity to Shock (Impact) by Drop Weight Apparatus of E. Lenze & H. Kast (104-07); Determination of Sensitivity to Friction (Medición de la sensibilidad al rozamiento) (107); Determination of Sensitivity to Initiation by Detonation (110-12); Determination of Sensitivity to Initiation by Influence (112-13); Determination of Power of Explosives using Trauzl Test (113-17), Small Lead Block Test (117), Quinan Apparatus (118), Guttman Apparatus (118-19), Ballistic Pendulum (119-20), Mortar (Mortero probeta) (120-21); Determination of Efficiency of Initiating Devices by Lead Plate Test (121-23), Nail Test (123), Sand Test (124) and Acoustic Tests (124); Determination of Characteristics of Flames Produced on Explosion (125-29)

14) G.J. Mueller, "Equipment for the Study of Detonation Process", PATR 1465 (1945)

15) L.C. Smith & E.H. Eyster, "Physical Testing of Explosives. Miscellaneous Sensitivity Tests, Performance Tests", OSRD Repr 5746 (1945)

16) F.W. Brown et al, "Sensitivity of Explosives to Initiation by Electrostatic Discharges", USBurMines RI (Report of Investigation) 3852 (1946)

- 17) D.L. Kouba, "Sensitivities of Military Explosives", Hercules Powder Co Rept **RI 2082** (1947) (Contract NOrd-9490)
- 17a) C.G. Montgomery, Editor, "Techniques of Microwave Measurements", McGraw-Hill, NY.(1947), Chap 10, p 666 (No later edition)
- 18) Stettbacher (1948): Determination of Density (pp 7-8); Determination of Heat of Explosion (8-10); Determination of Detonation Velocity by Siemens Spark Chronograph, by Rotating Drum Apparatus and by Dautriche Method (10-13); Determination of Volume of Gases Evolved on Explosion (13-14); Temperature Developed on Explosion (14-16); Size and Duration of Flame Developed on Explosion (16-18); Burning of Propellants (18-20); Brisance by Metal Plate Tests (110-11); Power by Trauzl Test (111-13); Lead Block and Copper Cylinder Compression Tests (113-15); Ballistic Pendulum Test (115-16); Fragmentation Test (Geschoss-Splitter Probe (118); Impact Test by Falling Weight (118-20); Deflagration Point (Verpuffungstemperatur) (120); Friction Test (120-21); Rifle Bullet Test (Beschussprobe) (121)
- 18a) C.H. Chandler, "An Investigation of Dielectric Rod as Wave Guide", JApplPhys **20**, 1188-92 (1949)
- 19) E.H. Eyster et al, "The Sensitivity of High Explosives to Pure Shocks" NOLM **10336** (1949)
- 19a) D.L. Copp et al, "The Sensitiveness of Explosives", PhilTransRoySoc **241**, 197-297 (1949)
- 20) W.R. Tomlinson, Jr & A.J. Clear, "Development of Standard Tests. Application of the Impact and Sand Tests to the Study of Nitroglycerine and Other Liquid Explosives", PATR **1738** (1949)
- 21) J.H. McIvor, "Fragmentation Test Procedures", PicArnsTestingManual **5-1** (1950)
- 21a) J.H. McIvor, "Friction Pendulum Test", Ibid **7-1** (1950)
- 21b) J.H. McIvor, "Ballistic Mortar Test", Ibid **7-2** (1950)
- 22) C. G. Sandler, "An Acoustic Technique for Measuring the Effective Dynamic Bulk Modulus of Elasticity and Associated Loss Factor of Rubber and Plastics", NavOrd Rept **1524** (1950)
- 23) W.H. Rinckenbach & A.J. Clear, "Standard Laboratory Procedures for Sensitivity, Brisance and Stability of Explosives", PATR **1401**, Rev 1 (1950) [Superseded by PATR **3278** (1965)]
- 23a) R.H. Stresau & L.B. Starr, "Some Studies of Propagation of Detonation Between Small Confined Explosive Charges", NOLM **10577** (1950)
- 24a) Stettbacher, Polvoras (1952): Heat of Detonation (pp 10-12); Velocity of Detonation by Rotating Drum Camera and by Dautriche Method (12-15); Volume of Gases (16-17); Temperature of Detonation (17-19); Size and Duration of Flame Produced on Explosion (19-20); Burning of Propellants (22-4); High-Speed Photographic Methods (44-7); Brisance by Plate Test (141-42); Power by Trauzl Test (142-45), by Compression Test (Ensayo por recalado) (145-46) and by Ballistic Pendulum (146); Fragmentation Test (148-49); Impact Test (Ensayo con un pilón) (150-53); Temperature of Deflagration (153); Friction Test (Ensayo de rozamiento) (153-54); Rifle Bullet Test (Ensayo de impacto) (154)
- 24b) Belgrano (1952): Determination of Density by Method of Bianchi (pp 15-18); Stability of Explosives by Method of Abel (Saggio Abel) , and by Angeli Test (18-23); Trauzl Block Test (Metodo del Blocco di Piombo) (23-8); Cratering Test (Saggio del Trauzl nella Terra) (28-30); Velocity of Detonation by Methods of Dautriche and Metregang (30-38); Lead Block Compression Test (Hess Test) (39-43); Detonation by Influence or Sympathetic Detonation (43-7); Sensitivity to Initiation (Sensibilità all'innescamento) (48-9); Sensitivity to Shock by Drop Weight

Apparatus (Saggio alla "Berta") (49-51); Steel Plate Test (Prova della Piastra di Acciaio) (51-2); Ignition Temperature (Temperatura di Accensione) (52-3); Velocity of Bullets by Le Boulangé Chronograph (294-97)

25) W.M. Slie & R.H. Stresau, "Small Scale Plate Dent Test of Confined Charges", NavOrd Rept **2422**(1952)

26) W.E. Dimmock, Jr, "A Small Scale Gap Sensitivity Test", NavOrd Rept **2494** (July 1952) (Description of original SSGT) (Conf)

27) Taylor (1952), Measurement of Detonation: by Dautriche (pp 24-28) and by Rapid-Photography Methods (28-32); Heat of Explosion by Calorimetric Bomb (40-2); Temperature of Explosion (43-7); Power or Strength of High Explosives by Trauzl Lead Block Test, Ballistic Mortar Test and Pendulum Test (185-86)

28) J. Savitt, "Effect of Acceptor Explosive Confinement upon Acceptor Sensitivity", NavOrdRept **2938**(1953)

28a) J. Savitt, "A Sensitivity Test for Castable Liquid Explosives, Including Results for Some New Materials", NavOrdRept **2997** (1953) (Conf ?)

29) Anon, "Military Explosives", PATR **9-1910/TO 11A-1-34**(1955): Sensitivity to Impact (pp 43-7); Sensitivity to Friction (47-9); Sensitivity to Frictional Impact, which includes Rifle Bullet Impact Test (49); Sensitivity to Heat and Spark, which includes Explosion Temperature Test (49-52); Sensitivity to Initiation by Sand Test (52-3 & Fig 10 on p 54); Stability Determinations, which include: 75°C International Test, 100°C Heat Test, Vacuum Stability Test, and Potassium Iodide-Starch (KI) Test (53-60); Brisance Determinations which include: Sand Test, Plate Dent Test, and Fragmentation Test (60-4 and Fig 16 on p 65); Sympathetic Detonation or Detonation by Influence by Gap Test, Power by Ballistic Pendulum and Trauzl Lead Block

Test (68-71); Blast Effect (72-6); Cratering Effect (76-8); Munroe-Neumann Effect (78-85); Surveillance Tests, which include 65.5°, 120° & 134.5°C Tests (243-46) (Superseded by Ref 81)

29a) M.A. Cook et al, "Measurement of Detonation Velocity by Döppler Effects at Three-Centimeter Wavelength", JApplPhys **26**, 126-28(1955)

30) W.E. Deal, Jr, "The Measurement of Chapman-Jouguet Pressure for Explosives Measurements", 2ndONRSympDeton (1955), pp 209-24

31) W.S. Cramer, "Bulk Compressibility Data on Several Explosives", NavOrdRept **4380**(1956)

32) L.N. Cosner & R.G.S. Sewell, "Initiation of Explosives Through Metal Barriers"; Paper presented at the Symposium on Detonation Wave Shaping, Jet Propulsion Laboratory, Pasadena, Calif, June 5-7(1956)

33a) Yaremenko & Svetlov(1957): Ignition Temperature (pp 17-18); Sensitiveness to Flame (18-19); Sensitiveness to Impact (19-24); Sensitiveness to Friction (24-5); Initiation by Influence (25-8); Stability Tests, including KI-Starch Paper Test, Litmus Paper Test at 106.5°C, Loss of Weight Test at 95°C (28-32); Hygroscopicity Test (32-4); Caking (35-6); Water Resistance (36-41); Density (41-43); Exudation (43-4); Determination of Critical Diameter (61-2); Determination of Detonation Velocity (62-6); Determination of Volume of Gaseous Products of Detonation in Bomb of Dolgov (75-83); Heat and Temperature of Explosion (83-92); Power by Trauzl Test, Ballistic Pendulum and Ballistic Mortar Tests (99-101); Brisance by Lead Block Compression and Ballistic Pendulum (101-105); Shaped Charge Effect (105-107)

33b) Gorst (1957): Ignition Temperature (pp 28-9); Impact Test (29-31); Rifle Bullet Test (31); Sensitivity to Friction (31-2); Sensiti-

vity to Initiation by Detonators (32-3); Initiation by Influence (33-4); Stability Tests, including Abel Test, Vieille Litmus Paper Test, Loss of Weight Test and Manometric & Electrometric Tests (40-2); Determination of Pressure of Gaseous Products of Burning by Manometric Bomb and by Crushers (56-8); Determination of Detonation Velocity by Method of Dautriche (75-6); Brisance by Lead Block Compression and by Fragmentation Tests (81-2); Capacity of Doing Work (Fugasnost' or Fugasnoye Deystviye in Rus) or Power by Ballistic Pendulum Test, Trauzl Test and Cratering Test (82-5); Action of Explosion on Barricades of Concrete, Reinforced Concrete and of Bricks (86); Shaped Charge Effect (Munroe-Neumann Effect (87-8)

34) W.E. Deal, *JChemPhys* **27**, 796-800 (1957) (Measurement of Chapman-Jouguet pressure for explosives)

35) Dunkle's Syllabus (1957-1958): Shock Tube Studies in Detonation (pp 123-25); Determination of Pressure Effect (144-45); Geometrical and Mechanical Influences (145-48); Statistical Effects of Sensitivity; Discussion on Impact Sensitivity Evaluation (148-49); Pressure in the Detonation Head (175); Temperature of Detonation (176); Charge Density, Porosity, and Granulation (Factors Affecting the Detonation Process) (212-16); Heats of Explosion and Detonation (243-46); Pressures of Detonation (262-63); A brief description of Trauzl Block Test, Sand Test, Plate Dent Test, Fragmentation Test, Hess Test (Lead Block Crushing Test), Kast Test (Copper Cylinder Compression Test), Quinan Test and Hopkinson Pressure Bar Test (264-67); Detonation Calorimeters (277-78); Measurements of Detonation Pressure and Temperature (297-309) (16 Apr 1958 - - also presented on 14 May 1957 by B.T. Fedoroff, pp 1-4); Blast Effects in Air, Water, and Solids (311-29); Deformation of Solids (320-23); Metal-Charge Interaction (323-5); Explosion of Shells and Bombs (325-26); Action of Fragments on Target (327-28); Shaped Charges (329-42); Comparison of Theory and Experiment (373-90)

36) Cook (1958). Following experimental procedures are either described or listed, including their refs: Wave-Speed Photography for Observation of Detonation Phenomena (pp 22-9 and Figs 2.1 to 2.5. Table 2.1 on p 23 lists properties of some expls); Pin Method and Pin-Oscillograph Method for determination of detonation velocity and of other detonation phenomena (pp 29-31 and Figs 2.6 & 2.7); Microwave Method for detn deton velocity (pp 31-2); Measurement of Detonation Pressure (pp 32-5) and Figs 2.8 & 2.9 on p 34); High-Speed Radiography for studying detonation phenomena (pp 35-6); Available Energy or Maximum Available Work Potential by Trauzl Block and Ballistic Mortar Tests (pp 36-7); Measurement of Temperature in Detonation (pp 37-8); Impact Sensitivity (pp 38-40 & Figs 2.11 & 2.12 on p 40); Thermal Decomposition of Explosives (pp 39-41); Miniature Charge Techniques (p 41); Shock-Pass-Heat-Filter (SPHF) Plate Test (p 83); and Probe Methods of Ionization Determinations (pp 144-45 and Figs 7.1 & 7.2 on p 144)

37a) W.R. Tomlinson & O.E. Sheffield, "Properties of Explosives of Military Interest", *PATR* **1740**, Rev 1, Vol 1 (1958); Vol 2 (1958) (Conf). Superseded by AMCP 706-177 (1967) (See Ref 82)

37b) G.P. Cachia & E.C. Whitbread, "The Initiation of Explosives by Shock" *PrRoySoc* **246A**, 268-93 (1958) [Description of experiments using the SSGT (Small Scale Gap Test)]. A similar apparatus is described in Refs 55b and 80

38a) C.H. Winning, "The Underwater Shock Wave Initiation of Cast Pentolite", *PrRoySoc* **246A**, 288-96 (1958). The apparatus used in these tests consisted of a cubic tank 15 by 15 inches, which contained receptors supported on short pegs located around a primer (donor) suspended on a wire loop suspended in the center of the tank filled with water. The donor was a spherical cast Pentolite chge weighing ca 73 g and of density 1.70 g/cc. It was centrally initiated by means of a

pressed RDX pellet (1/4 x 3/8 inch) and a No 8 arc-fired cap. Receptors were cylindrical cast Pentolite charges prep'd by a special method (see p 389) to make them air-free. Argon flash lamps were used as a source of illumination for the photographs which were taken at selected times and the flash exposure was timed by a Primacord delay line to the flash lamp

The tests have shown that initiation of cast Pentolite receptors underwater by shock wave was facilitated by combined frontal and lateral influences. Initiation did not occur exclusively at the front end of the receptors. When the receptors were beyond about 3.5 radii from the center of the spherical cast Pentolite primer, the initial low-velocity propagation in the receptors proceeded longer than 15 or 20 μ sec and seldom developed into high-velocity detonations. Abnormally dense receptors tended to react longer in a low-velocity propagation even when fairly near a primer

38b) G.F. Cawsey et al, "Observation of Detonation in Solid Explosive by Microwave Interferometry", *PrRoySoc* **248A**, 499-521 (1958)

38c) A.B. Amster et al, "Detonability of Solid Propellants, Test Methods and Instrumentation", *NavOrdRept* **5788** (1958)

38d) H. Koenen et al, *Explosivst* **8**, 178 (1958) [Historical review of the impact test. W. Will was the first to use it (1906) and then H. Kast in 1909]

39) S.S. Penner & B.P. Mullins, "Explosions, Detonations, Flammability and Ignition", Pergamon Press, NY (1959)

39a) A.B. Amster & R.L. Beauregard, "Pressure Sensing Probes for Detecting Shock Waves", *RevScientInstrs* **30**, 942 (1959)

40) M.A. Cook et al, "Instrumental Card-Gap or SPHF-Plate Test", *JApplPhys* **30**, 1579-84 (1959). The apparatus illustrated in Fig 1 consisted of electric detonator, booster, donor, barrier (gap), called SPHF (Shock-Pass-Heat-Filter) and receptor was used for

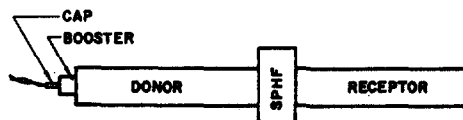

FIG 1. General setup for shock-pass heat-filter (SPHF) initiation of explosives

studies of DDT (Deflagration-to-Detonation Transition). The observations were made with a rotating mirror framing camera at speeds ranging from 0.83 to 8.3 μ sec per frame, using 35 mm film either black & white or color. Also were used rotating mirror streak cameras with writing speeds of 0.3 to 5.5 km/sec and 4- and 5-inch wide film. Lighting for photography of nonluminous events was provided by flash bombs of cast TNT or Comp B fired into argon or air-filled cardboard boxes having polyethylene end windows. As a donor Comp B, Grade 1 (RDX 55.2, TNT 40.0, polyisobutylene 1.2 and wax 3.6%) was used and as a receptor (acceptor) either 70/30-Baratol or HBX-1 (RDX 40, TNT 38, Al 17 & wax 5% + 0.5% CaCl_2 added) was used. Glass plates were used as SPHF, but steel, Al or brass plates were also tried. The thickness of the barrier was varied to control the intensity of the shock transmitted to receptor [See also under Detonation (and Explosion), Development from Deflagration]

41) Baum, Stanyukovich & Shekhter (1959: Determination of Ignition Temperature using Standard Russian Method and Apparatus of M.M. Kostevich (pp 28-30); Sensitivity to Impact using Curved Drop Weight Apparatus (Dugovoy Kopër) and Vertical Drop Weight Apparatus (Vertikal'nyi Kopër) (30-8); Determination of Sensitivity to Stab by Apparatus of Rdultovskii called Elektrokopër (38); Sensitivity to Friction by Friction Pendulum (38-9) and by two other devices which are shown on Figs 12 & 13 of p 40; Sensitivity to Initiation (44-6); Determination of Heats of Explosion and of Combustion (94-6); Determination of Pressure, Volume and Composition of Products of Explosion conducted in Manometric Bomb shown on Fig 33, p 140; Ballistic Pendulum (Fig 147, p 441); Lead

Block Compression Test (Fig 150, p 444); Copper Cylinder Compression Test (Fig 153, p 446); Lead Block Compression Test (Fig 154, p 448); Detonation by Influence Through the Air (Fig 252, p 765)

42) Andreev & Belyaev (1960): Determination of Stability of Explosives by Method of Heating Until the Appearance of Brown Fumes (pp 113-14), by Bergmann & Junk Test (115), by Vieille Test (Litmus Paper Test at 115°) (115-16), Will Test at 135° (116), Loss of Weight Test (116-17), Obermüller Test (117-18), Vacuum Stability Test (119), Taliani Test (119), Hansen Test (119-20), Abel Test (120-22), British Test (Silvered Vessel Test) (122), and Lambrey Test (123-24); Determination of Burning Rates (136-38); Determination of Detonation Velocity by Method of Dautriche, by High-Speed Photographic Method and by Oscillographic Method (210-22); Determination of Sensitivity to Impact by Kast Apparatus, Kozlov Apparatus and Weller Apparatus (311-20); Sensitivity to Friction by US Bureau of Mines Apparatus, and by Bowden Apparatus (320-24); Rifle Bullet Test (324-25); Determination of Ignition Temperature by Various Methods (325-28); Sensitivity to Initiation by Detonators (328-29); Determination of Effectiveness of Initiating Explosives (332-33); Determination of Effectiveness of Detonators (333-37); Determination of Heat of Explosion using British Bomb (Fig 8.2, p 423) and Bomb of Apin & Belyaev (Fig 8.3, p 423); Determination of Erosion in Weapons (430-32); Determination of Pressure of Explosion (442-44); Determination of Power by Trauzl Test, by Ballistic Pendulum, by Ballistic Mortar, by Cratering Test and by Blast Wave Test (465-77); Determination of Brisance by Lead Block Compression (Hess Test) and Copper Cylinder Compression (Kast Test) (476-81); Effectiveness of Shaped Charges Tests (481-89); Testing of Permissible Explosives in Galleries (492-97); Size and Duration of Flame in Explosions (516-20)

42a) H.S. Napadensky et al, "The Behavior of Explosives at Impulsively Induced High

Rates of Strain", 3rdONRSympDeton(1960), Vol 2, pp 420-35 (Included is description of Type 1 and Type 2 Impact Tests, which are also described in Ref 67)

42b) AB Bofors Nobelkrut, "Analytical Methods for Powder and Explosives", Bofors, Sweden(1960): Specific Gravity by Mohr-Westphal Balance Method and by Pycnometer Method (pp 22-3); Granulation by Sieving Method (23); Bulk Density (23); Melting Point b, Beaker Bath and by Roth Apparatus (24-5); Drop Point by Ubbelohde Apparatus (25-6); Solidification Point using two methods (26-7); Flash Point by Abel-Pensky Apparatus and by Pensky-Martens Closed Tester (27-9); Refractive Index by Abbé Refractometer (29-30); Stability Determinations by Abel Heat Test (modified), by Heat Test at 134.5°C with Standard Methyl Violet Test Paper, by Bofors Surveillance Test at 65°C, by Lenze & Pleus Test at 75° & 100°C (International Test), by Heat Test at 120°C (Brown Fumes Test for Double-Base Propellants), by Heat Test at 135°C (Brown Fumes Test for Single-Base Propellants), Bergmann & Junk Tests at 132°C and 120°C, by Schulze-Tiemann Method, by Vacuum Test at 120°C and 140°C, and by Dutch Test at 105° and 110°C (41-60); Explosion Temperature Test (60-2); Trauzl Lead Block Test (63); Falling Weight Test (Impact Test) (63-4); Lead Plate Test (64); Detonation Velocity Determinations, by Direct Method-Spark Chronograph, and by Indirect Method-Dautriche (64-5); Specific Gravity and Bulk Density of Propellants (172-73); Calorimetric Value of Propellants (175-78); Erosiveness of Propellants by Vieille Erosion Bomb (178-79); Stability Tests for Propellants and Explosion Temperature (Same as described on pp 43-52 and 60)

43) V.S. Ilyukhin et al, "Measurement of Adiabatic Shock Waves of Cast TNT, Crystalline Hexogen and Nitromethane", Dokl-AkadN 131, 793-96(1960) & CA 55, 24013 (1961); Engl Transln in SovietPhysics Doklady, No 5, 337-40(1960). The reflection method was used, with 5-mm Cu plates

as interstitial material. Comparison of the results obt'd is shown on a graph

44) V.M. Zaitsev et al, "Electromagnetic Method for Measuring the Speed of Explosive Products", DoklAkadN **132**, 1339-40 (1960) & CA **55**, 17007 (1961) [A new method has been described, based on measuring the electromotive force in a conductor moving in a magnetic field with expln products. A Cu or Al foil 0.3-0.5 mm thick was used as the conductor, the emf being recorded by means of a cathode-ray oscillograph, and the speed (u) being calcd from the equation:

$$u = (\epsilon/Hl) \times 10^8 \text{ cm/sec}$$

where ϵ = emf, H = magnetic field strength and l = conductor length

The expts conducted with TNT and TG 50/50 (compn is not known) gave values ca 3% lower than those obt'd by other methods]

45) I. Jaffe et al, "Determination of the Shock Pressure Required to Initiate Detonation of an Acceptor in the Shock Sensitivity Test", NavOrdRept **6876** (1960) & ARS-J **32**, 22-5 (1962)

46) Dunkle's Syllabus (1960-1961): Shock Tube Studies in Detonation (pp 11.d, 11.f, 11.g, & 11.h); Additional Discussion on Impact Sensitivity Determinations (p 12.d); Thermal Ionization and Initiation of Explosives (p 13.f); Pressure in the Detonation Head (pp 14.f and 14.g); Confinement and Obturation (and Other Factors Affecting the Detonation Process) (pp 18.a-18.e); Thermochemistry and Energetics of Detonation: Energy Release (pp 20.a-20.c); Energy and Temperature of Detonation (pp 22.a-22.e); Factors Affecting Heat of Detonation (pp 23.a-23.f); Relation between Deflagration and Detonation (pp 24.a-24.f); Measurements of Detonation Pressure and Temperature (pp 25.a-25.d)

47a) J.N. Ayres, "Standardization of the Small Scale Gap Test Used to Measure the Sensitivity of Explosives", NavWeps Rept **7342** (Jan, 1961), NOL, White Oak, Maryland

[Description of original and revised SSGT is given. Revised test employs a 1.4-inch long, 0.2-inch diam RDX column loaded in a brass cylinder as a donor. The acceptor explosive was of similar configuration. The sensitivity to initiation by influence of an explosive was determined by loading it in the brass acceptor tube as shown on Fig 1 of NOLTR 66-87 (1966) (See Ref 80) and detonating it by donor expl (which was pressed RDX). Variable thicknesses of Lucite were used as a barrier in the gap to moderate the donor output. The mean firing sensitivity was usually determined from the thickness of barrier at which 50% response was obtained. Dimensions of apparatus were the same as given in Ref 80 and the donor was the same (RDX pressed to density 1.56 g/cc). Instead of Lucite barrier which was used by Ayres, PMMA (Polymethylmethacrylate) was used in Ref 80]

47b) A.W. Campbell et al, Physics of Fluids **4**, 511 (1961) (Large scale gap test)

48) Donna Price & I. Jaffe, "Large Scale Gap Test: Interpretation of Results for Propellants", NavWeps Rept **7401** (1961) & ARS-J **31**, 595-99 (1961). Shock sensitivities for various proplnts were detd using Large Scale NOL Gap Test, which is illustrated in Fig 2. This test is also known as LSGT (Large Scale Gap Test) to distinguish it from SSGT (Small Scale Gap Test), which is described in Ref 47. It is one of the varieties of "card gap tests". Two pressed Tetryl pellets ($\rho=1.51$ g/cc) (donor) supply the shock after being initiated by an electric detonator. The shock is transmitted thru the card gap to a moderately confined propellant (acceptor). The gap serves as a "shock attenuator" and can be made of Lucite or the equivalent cellulose acetate. A mild steel "witness plate" served as the criterion of "detonation". A test was considered positive if a hole was punched. As a measure of charge sensitivity, served the length of gap at which there is 50% probability according to the above criterion. Results of tests are given in the report

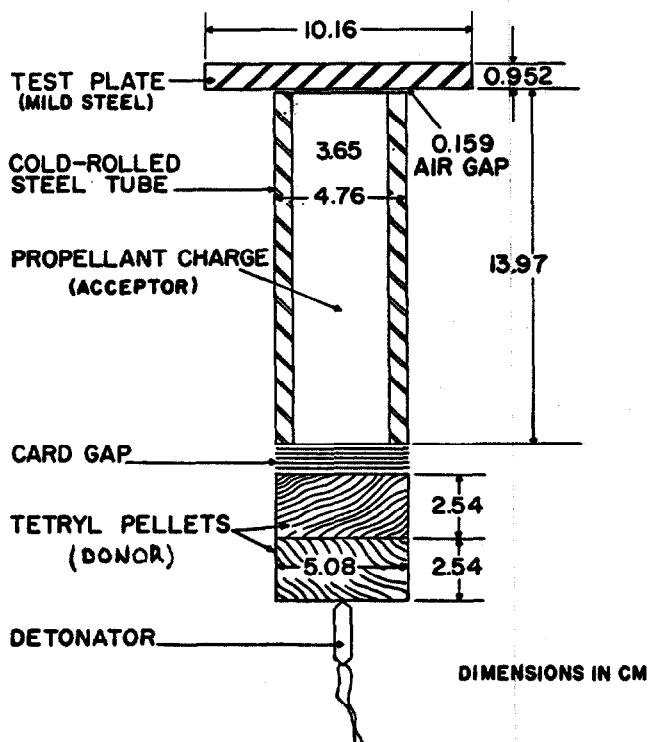

Fig 2 LSGT Assembly

49) J.N. Ayres et al, "A Method for Determining Detonation-Transfer Probabilities", NavWeps Rept 7411(1961)

50) A.J. Clear, "Standard Laboratory Procedures for Sensitivity, Brisance and Stability of Explosives", PATR FRL-TR-25 (1961) [Superseded by PATR 3278(1965)]

50a) S.M. Brown & E.G. Whitbread, "CollInt-CentreNatRechScient, Saint Louis, France, 28 Aug - 2 Sept, 1961 (Comparison of Shooting and Barrier Test) (quoted as Ref 2 by N. Lundborg) (See our Ref 64)

51) Anon, "Military Standard Propellants, Solid: Sampling, Examination and Testing" MIL-STD-286A (1961): Method 403.1.2 - Vacuum Stability Tests at 90° and 100°C; Method 404.1.2 - Heat Tests at 120° and 134.5°C; Method 406.1.1 - Taliani Test;

Method 502.1.1 - Bulk Density by DuPont Densimeter; Method 502.2.1 - Bulk Density (Pounds per Cubic Foot); Method 503.1.3 - Hygroscopicity of Small Arms Propellants; Method 503.2.2 - Hygroscopicity of Cannon Propellants by Equilibrium Method; Method 504.1.1 - Dimensions of Grains; Method 504.3 - Dimension of Sheet Propellant; Method 505.1 - Compressibility of Grains; Method 506.1 - Granulation; Method 507.1 - Density of Loading; Method 510.1.1 - Specific Gravity by Pycnometer Method; Method 510.2.1 - Specific Gravity of Liquids by Westphal Balance

52) I. Jaffe et al, "Determination of Shock Pressure Required to Initiate Detonation of an Acceptor in the Shock Sensitivity Test", ARS-J 32, 22-25 (1962). In experiments performed at NOL by Jaffe et al, the assembly shown in Fig 3 was used to measure the attenuation of a shock wave in a Lucite rod. The shock wave was initiated by a

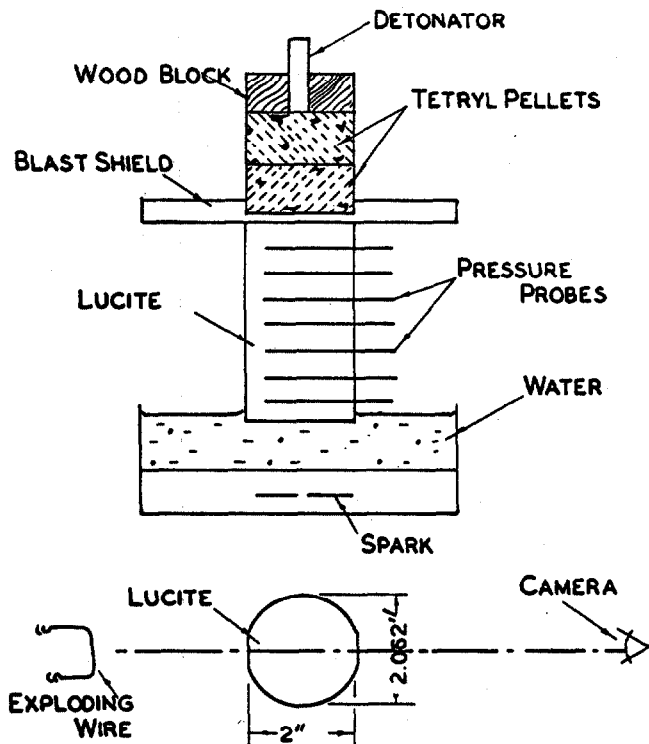

Fig 3 Experimental assembly for the measurement of the shock attenuation in Lucite and water

"Seismo" detonator followed by a Tetryl donor consisting of two pellets (each 2-inch diam by 1-inch length), pressed to a density of 1.51 g/cc. A series of four experiments was made on Lucite rods (2-inch diam by 4 or 5-inch length), in which carefully positioned pressure probes were used to follow the shock front. A 2nd series of four tests was made on Lucite rods in which the shock front was followed by both pressure probes and a smear camera. The reaction of the pressure probes to the shock in both series was transmitted to an oscilloscope (Tektronic No 535), where a permanent record of the oscilloscope trace was made by Polaroid camera. Prior to each test, the calibrations were obtained on the oscilloscope from a time-mark generator (Tektronic No 181). In addition to Tektronic oscilloscope, a raster oscilloscope was used. A detailed description of both the pressure probe and the related electronics was given by Amster et al in Refs 38c & 39c. The charge was assembled vertically with its end submerged ca 0.25 inch below the surface of water contained in a small trough. A Lucite blast shield was used to prevent the products resulting from detonation of Tetryl pellets from obscuring the view of the camera. The ionization probe placed at the Tetryl-Lucite interface was used to trigger both the oscilloscope and camera. The Lucite rod was backlit by an exploding wire, and a fiducial (reference) point was established on both records (pressure probe and camera) by a spark which was initiated at a given interval after the reaction took place.

A 3rd series of tests was made on attenuators composed of cellulose acetate cards (2-inch diam by 0.01-inch thickness) and Lucite disks (2-inch diam by 0.50- or 1.0-inch length). The shock velocity in this composite gap was followed by the pressure probes. This test proved that the composite gap and the Lucite gap are comparable.

Results of tests are given in Tables 1-4 and also shown in Figs 2-6 of paper, but are not reproduced here.

53) Anon, "Military Standard Explosives:

Sampling, Inspection and Testing", MIL-STD-650(1962): Method 201.2 - Bulk or Apparent Density (Wet Method); Method 201.3 - Ditto (Dry Method); Method 202.1 - Density (in Vacuo); Method 203.1 - Specific Gravity by Mercury Replacement Method; Method 203.2 - Specific Gravity by Bottle Method; Method 204.1 - Granulation by Dry Method; Method 204.2 - Granulation by Wet Method; Method 205.1 - Average Particle Diameter by Fisher Sub-Sieve Method; Method 206.1 - Particle Size by Microscopic Method; Method 207.1 - Settling Number; Method 208.1 - Hygroscopicity by Equilibrium Method; Method 209.1 - Melting Point by Capillary Method; Method 210.1 - Solidification (or Setting) Point; Method 211.1 - Plasticity by Elongation Method; Method 211.2 - Plasticity by Modulus or Compressibility Method; Method 212.1 - Viscosity by Efflux Test; Method 501.1 - Stability by 75°C International Test; Method 502.1 - 100°C Heat Test- Method 503.1 - 100°C and 120°C Vacuum Stability Tests; Method 505.1 - Impact Sensitivity Test by US Bureau of Mines Apparatus; Method 506.1 - Explosion, Temperature Test; Method 507.1 - Sensitivity to Initiation by Sand Test Method; Method 508.1 - Brisance by Sand Test; Method 509.1 - Initiating Efficiency by Sand Test

54) Andrej Maček, "Sensitivity of Explosives", ChemRevs 62, 41-63 (1962). "The sensitivity of an explosive can be defined as the minimum amount of energy that must be imparted to the explosive, within limited time and space, to initiate explosive decomposition" (p 60). This definition can serve as a basis of quantitative fundamental treatments provided the imparted energy is thermal and provided its initial distribution in time and space is known. If the energy is not supplied directly as heat, but by mechanical means (such as a shock), there is the additional requirement of quantitative assessment of conversion of the stimulus into heat (p 60)

Two mechanical tests for sensitivity are described in the paper: the Gap Test and

the Impact Test

The Gap Test, sometimes called Barrier Test or Booster Test, was first suggested by H. Muraour in MAF 12, 559(1933), but the first systematic study of the phenomenon was done by G. Herzberg & R. Walker, Nature 161, 647(1948). Since that time many expls labs both in the US and abroad have adopted and standardized it as a practical test of sensitivity. The apparatus used by Maček is similar to the "NOL Gap Test Assembly", previously described in NOL Reports such as NavWepsRept 7401(1961) (Our Ref 48). It is shown here as Fig 4. Tetryl pellets served as a donor, the gap consisted of several cellulose acetate cards 0.25 mm thick, the acceptor was unconfined and the witness plate was of steel. For given donor and gap materials and for fixed geometrics of both the donor and the acceptor, the gap thickness which gives the marginal shock strength, called the "gap value"

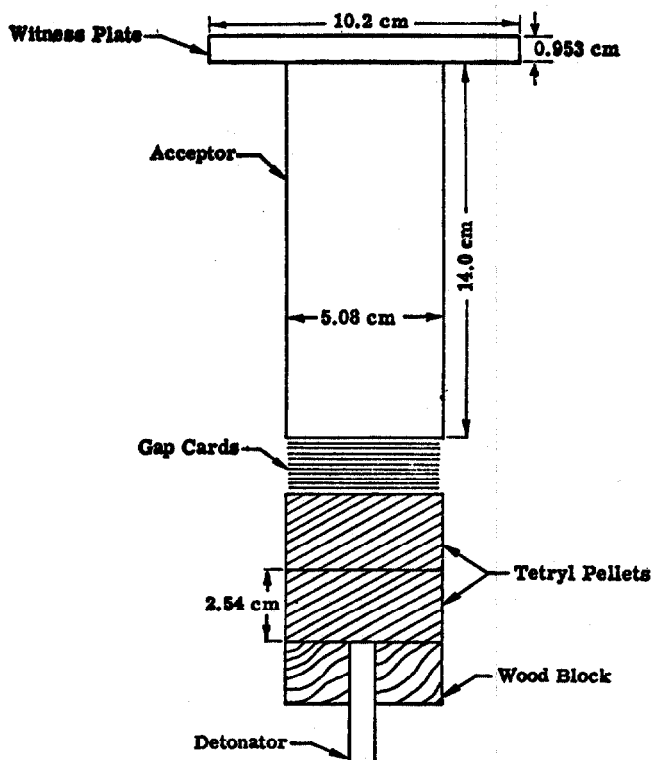

Fig 4 The Naval Ordnance Laboratory gap test for solids. The gap consists of a varying number of cellulose acetate "cards," 0.25 mm. thick. The witness plate is steel.

or the "50 per cent point", is a quantitative measure of the sensitivity of the acceptor to shock. Sensitive expls have a high and insensitive ones a low gap value. A practical way to determine the gap value is to vary the gap until one arrives at two thicknesses n & n' where n means 100% detonations and n' gives 100% of failures; the gap value is then taken as $(n+n')/2$. Table 1 gives "gap values" for several expls and proplnts (pp 56-8). Gap test in which air space serves as a gap is employed for determination of "detonation by influence", also known as "sympathetic detonation"

Table 1

The US Naval Ordnance Laboratory Gap Test

| Material | Cast or Pressed | Density g/cc | Gap Value cm |
|------------------------|-----------------|--------------|--------------|
| DINA | Cast | - | 8.39 |
| RDX | Pressed | 1.640 | 8.20 |
| Pentolite | Cast | 1.684 | 6.70 |
| Tetryl | Pressed | 1.615 | 6.63 |
| EDNA | Pressed | 1.551 | 6.35 |
| Composition B | Pressed | 1.663 | 6.05 |
| Composition A | Pressed | 1.59 | 5.34 |
| Composition B | Cast | 1.704 | 5.24 |
| TNT | Pressed | 1.569 | 4.90 |
| Amatol | Cast | - | 4.12 |
| Explosive D | Pressed | 1.593 | 3.81 |
| TNT | Cast | 1.60 | 3.50 |
| Tritonal | Cast | 1.75 | 2.90 |
| Double-base propellant | - | - | 0.88 |
| Composite propellants | - | - | <0 |
| Ammonium Nitrate | Pressed | 1.615 | <0 |

The Impact Test, also called Falling Weight Test was devised by W. Will, SS 1, 209(1906) and by H. Kast, SS 4, 263(1909), and the history of test was reviewed by H. Koenen et al in Explosivstoffe 8, 178(1958). The test differs essentially from the gap test because its pressures (several hundred, or up to several thousand atmospheres) are much lower and its time scale (hundreds of microseconds, depending on the length of the hammer) much longer. In the test conducted at NOL, a 35-mg sample of expl or proplnt was placed on a

steel anvil of apparatus and covered by a cylindrical steel striker. When a 2.5-kg dropping weight (hammer) was released from a predetermined height, it hit the striker thus communicating the shock to the sample. Impact sensitivity rating of the explosive was defined by the drop height which gave a 50% probability of explosion. A method of arriving at 50% point was devised during WWII at the ERL, Bruceton, Pa. The test was counted positive if there was an ignition or expln produced on hitting the sample. This was indicated by noise (report) or by flash. As it is not always easy to decide if the test is positive or negative, the British investigators sometimes use as a criterion the amount of gas evolved under impact

Table 2 lists the 50% points obtd at NOL for several expls & proplnts. The quantitative ordering is the same as in the gap test

Table 2

The US Naval Ordnance Laboratory Impact Test

| Material | 50% Impact Height, cm |
|------------------------|-----------------------|
| PETN | 13 |
| Composite Propellants | 15-41 |
| RDX | 24 |
| HMX | 26 |
| Double-Base Propellant | 28 |
| EDNA | 34 |
| Pentolite | 38 |
| Tetryl | 38 |
| Composition A-3 | 60 |
| Composition B | 60 |
| Tritonal | 107 |
| Amatol | 116 |
| TNT | 200 |
| Ammonium Nitrate | >320 |

55a) G.D. Dorough et al, "Ignition of Explosives by Low Velocity Impact", pp 31-50 in Proceedings of International Conference on Sensitivity and Hazards of Explosives, London, Oct 1963 (Description of Susan Impact Test and comparison of its results for several explosives with those of Drop-Weight Impact Machine Test) (Susan Test is also described in Ref 67)

55b) A. Popolato, "Experimental Techniques Used at LASL (Los Alamos Scientific Laboratory) to Evaluate Sensitivity of High Explosives", Ibid, pp 831-50

The following tests are described:

A) *Thermal Induction Time Test* consists of measuring the induction time of a highly confined sample (ca 40 mg) of explosive, or explosive-inert mixture, as a function of temperature. The LASL version of the test is described by J. Zinn & R.N. Rogers in *JPhysChem* **66**, 2646(1962); it is modeled after the test developed by H. Henkin & R. McGill in *IEC* **44**, 1391(1952)

B) *Drop Weight Impact Test* used at LASL is a modified version of machine developed by E.H. Eyster & R.F. Davis at the Explosives Research Laboratory, Bruceton, Pa and described in *OSRD* **5744**(1945). The apparatus is known as "ERL Machine". Its drawing is given in Popolato's paper as Fig 2, p 835

C) *Small Scale Gap Test* used at LASL is a modified version of test described by Cachia & Whitbread (Ref 37b). It uses unconfined samples, 0.5-inch diam & 1.5-in long. A similar test is described by Donna Price (Ref 80) (See also Ref 47a)

D) *Large Scale Gap Test* used at LASL is a modified version of test described by Cachia & Whitbread (Ref 37b). It uses unconfined samples, 0.5 inch diam x 1.5 in long. A similar test is described by Donna Price (Ref 80) (See also Ref 47a)

E) *Rifle Bullet Test*, used at LASL, consists of placing an unconfined cylindrical chge of expl (2-inches in diam and 3-in long, at its working density) in a V-notched plastic holder that rests on a steel plate and firing at the chge a 90-grain cylindrical, steel projectile 0.3-inch in diam & 0.5-in long from a .30 caliber rifle. The velocity of bullet was measured with velocity screens (p 839)

F) *Skid Test*, intended to determine sensitivity to friction and impact of large charges of expls, was a version suggested by G.P. Cachia. The test consists of dropping bare hemispherical charges (shown in Fig 5) vertically onto a target inclined at an angle of

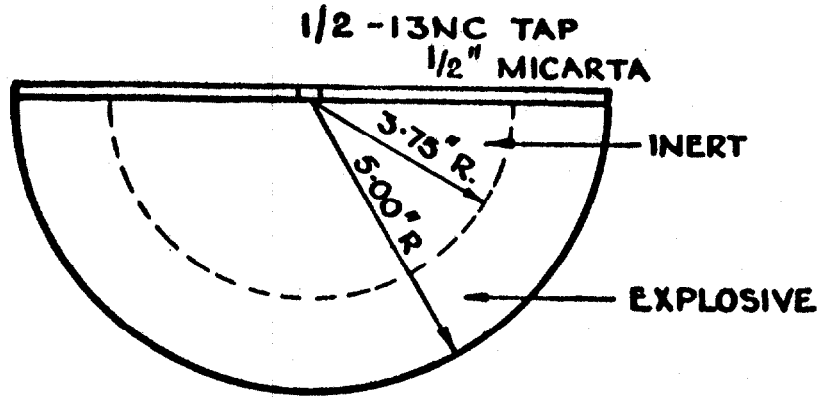

Fig 5 Drop Charge Used in Skid Test at LASL

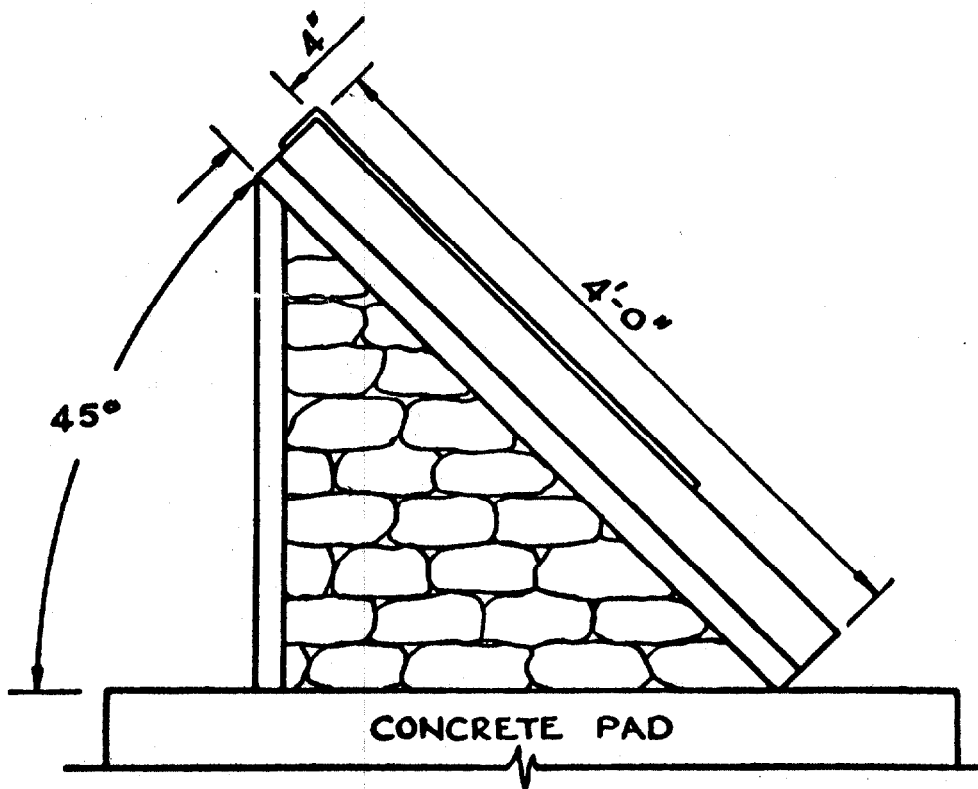

Fig 6 Target Used in Skid Test at LASL

45°. The target consists of a 2 x 2 inches, 10 gage steel plate coated with a thin layer of epoxy resin, sprinkling it with 30-mesh (max) sand, and curing. The plate rests on a rectangular steel pad 4.5 inches thick, as shown in Fig 6

The hemispherical drop charge, ca 10-inches in diam, consists of 9-lb inert core and 10-lb of expl. Results of test are reported in terms of the 50% height (measured in feet vertically from center of target) by up and down technique, using 15 to 20 drops for each expl sample

Table 3 lists results of skid test for several expls (pp 844-46)

Table 3

| Material | 50% Height (feet) |
|----------------|---|
| 90/10-PBX | 5.5 |
| 75/25-Cyclotol | 150 |
| 75/25-Octol | 75 |
| Octol+1% Wax | 150 |
| Comp A | 150 |
| Comp B | A small partial expln was obtd at 30 ft |

55c) A.I. Gol'binder, "Laboratorniye Raboty po Teorii Vzryvchatykh Veshchestv" (Laboratory Proceedings on Theory of Explosives), Razvuzizdat, Moscow (1963)

55d) J.N. Ayres, "Explosive Properties from Small Gap Test Measurements", Discussion at ERDE, Waltham Abbey, England, Oct 4, 1963

55e) Anon, "Ordnance Proof Manual", OPM 80-16 (Oct 1963) (Fragment velocity measurement) (Superseded by Ref 82b)

56a) J. Toscano et al, "Large-Scale Gap Test: Comparison of Tetryl and Pentolite Donors", AIAA-J 1, 964-66 (1963). The LSGT developed at NOL and described here under Ref 48 was originally calibrated using Tetryl as a donor. In order to study the adequacy of 50% pressure as a measure of shock sensitivity, a pressed Pentolite donor was used in the calibration by Toscano. The

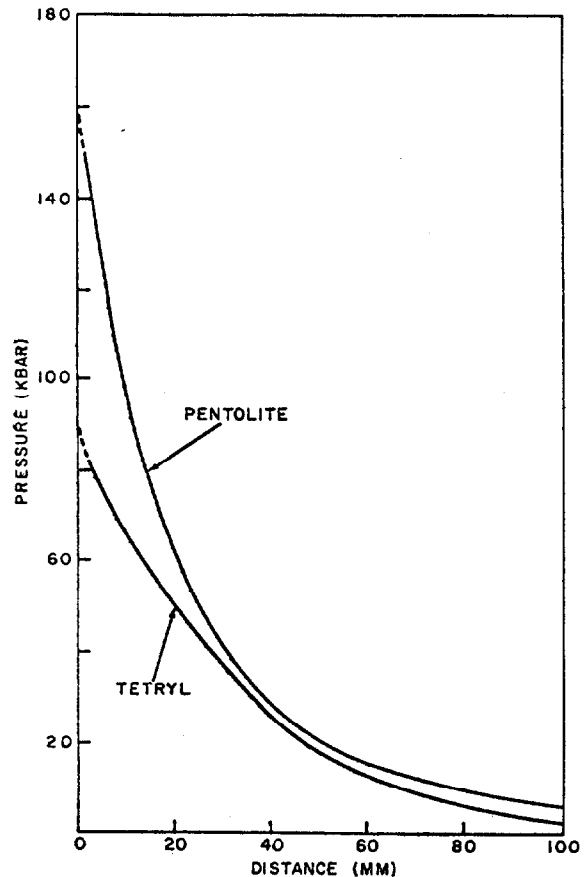

Fig 7 Pressure vs gap

pressures obtd at the 50% point for several expls were compared with those obtd with the standard Tetryl donor. As gap materials Plexiglas, Lucite, Cellulose acetate, or some combinations of them, were used. Method of calibration for determination of pressure vs gap for Pentolite and Tetryl is described but is not given here. We are reproducing, however, results of this calibration (See Fig 7, taken from p 866 of paper). It can be seen that at zero gap, the shock pressure of Pentolite is somewhat larger than that of the Tetryl. This larger pressure is attenuated rapidly and at ca 10 mm gap it is within the Tetryl pressure range and after 25 mm (ca 1 inch) of gap the curve of Pentolite approximates that of Tetryl. From this point on, both donors may be considered to give the same pressure amplitude within

the precision of the exptl data

Results of tests using as donors Pentolite & Tetryl and as acceptors Composition B-3 (cast), NGu & NG/Wax are shown here in Table 4. A good agreement for both donors was obtained for Comp B-3 as acceptor, but not so good for NGu and still worse for NGu/Wax. Some explanations for discrepancy are given in the paper

Table 4
Pentolite vs Tetryl: Shock Sensitivity

| Acceptor | Donor | Gap, 50% point | Pressure, kbar | Mean kbar |
|--|-----------|----------------|----------------|-----------|
| Comp B-3 (cast) | Tetryl | 209 | 16.4 | 17.2 |
| | Pentolite | 209 | 18.0 | |
| Nitroguanidine (NGu) =1.59 g/cm ³ | Tetryl | 46 | 63.0 | 73.1 |
| | Pentolite | 53 | 83.2 | |
| Nitroguanidine/wax 95/5 =1.55 g/cm ³ | Tetryl | 16 | 78.8 | 99.3 |
| | Pentolite | 25 | 119.7 | |

56b) T.V. Struchkovskaya & O. I. Kasimova, "Determining of Flash Points of Liquids and Gases", *TrGosMakeyevskNauchn-IzsledInst po Bezopasnosti Rabot v Gornoy Promyshlennosti* **15**, 375-85 (1963) & *CA* **62**, 12966 (1965)

56c) S.J. Jacobs et al, "The Shock-to-Detonation Transition in Solid Explosives", *9th Symp Combstn* (1963), pp 517-26 (A fairly complete bibliography of earlier work is given on p 526)

56d) S.J. Jacobs et al, "A High-Speed Focal Plane Shutter Framing Camera", *Proc 6th International Congress on High Speed Photography, The Hague, Sept 1962*, T. Willink, Haarlem (1963), p 57; and *SMPTE-J* **72**, 923 (1963)

56e) T.P. Liddiard, Jr et al, "Application of the High-Speed Focal Plane Shutter Camera to Explosives Research", *Ibid. Proceedings*, p 497 and *SMPTE-J*, p 927

56f) L.N. Gal'perin & K.K. Shvedov, "Method and Apparatus for Investigating of Tran-

sient Detonation Processes", *ZhFizKhim* **37**, 1182-86 (1963) & *CA* **59**, 3711 (1963); *Engl Translation Russ JPhysChem* **37**, 631-34 (1963): "A Technique for Investigating Transient Detonation Processes"

56g) T.P. Liddiard, Jr & S.J. Jacobs, "The Initiation of Reactions in Explosives by Shocks", *NOLTR* **64-53** (1964)

56h) J.W. Frazer & K. Ernst, "Chemical Reactivity Testing of Explosives", *Explosivstoffe* **12**, 4-9 (1964) (in Engl) & *CA* **60**, 14325 (1964)

56i) B. Hayes, "Electrical Measurements in Reaction Zones of High Explosives", *10th Symp Combstn* (1964), pp 869-74

56j) R.L. Jameson et al, "Electrical Resistivity Measurements in Detonating Composition B and Pentolite", *JApplPhysics* **35**, 714 (1964)

57) Giorgio (1964): Detonation Velocity by Methods of Dautriche, Le Boulangé, Mettegang, and Oscillographs (pp 39-48); Pressure of Explosion by Crusher Test (49-53); Volume of Gases Produced on Explosion (53-4); Heat of Explosion (54-6); Melting and Solidification Points (57-8); Stability by Method of Abel, German Test (Saggio Tedesco) at 120° & Taliani Test (58-62); Many other tests are listed on Table (63-5); and Silvered Vessel Test (Saggio del vasello argentato) (66); Hygroscopicity, Freezing and Exudation (pp 66-7); Ignition Point (67-8); Sensitivity to Flame, Sparks and High Temperatures in General (68-9); Sensitivity to Mechanical Action, such as Impact (70-2); Sensitivity to Initiation (72-3); Initiating Efficiency (73-4); Sensitivity to Impact by 8-mm Bullets Fired at High Velocity (74); Strength of Explosives by Trauzl Lead Block Expansion Test (75-81); Small Trauzl Block Test for Initiators (81-2); Lead Block Compression Test (Saggio Hess) (82-3); Copper Cylinder Compression Test (Saggio Kast) (83-4); Lead Plate Test (84-5); Sand Crushing Test (Prova di Frantumazione della sabbia)

(85-6); Ballistic Pendulum and Ballistic Mortar Tests (86-92); Ballistic Pendulum of Schmidt (93); Steel Plate Test (94); Detonation by Influence (95-6); Gallery Test for Permissible Explosives (97-8); and Examination of Flames (98-100)

58) T.P. Liddiard, Jr & Donna Price, "Recalibration of Standard Card-Gap Test", **NOLTR 65-43** (1965) [Gap tests, used to characterize explosive sensitivity to shock consist of the following parts: 1) A donor charge (such as RDX, PETN, Pentolite, HMX, Tetryl, etc), which can be initiated by a detonator; 2) A barrier (gap) which can be air, plastic, cardboard or metal; in experiments described in this report, it is PMMA (Polymethylmethacrylate) 3) An acceptor charge, which is an explosive or propellant to test; and 4) A means to detect reaction of the acceptor charge, usually a witness plate of metal. The gap thickness is varied until the acceptor is initiated to detonation in 50% of the trials; this critical thickness is called the "50% gap". The larger the gap, the more sensitive is the explosive to initiation by shock

In the past these tests were rather qualitative and one of the chief disadvantages was the lack of knowledge of the pressure transmitted to the acceptor. With the advent of calibration, however, the significance of gap tests was greatly increased. After discussing briefly the work on calibration done by various scientists between the years 1949 & 1965. Liddiard & Price stated that the purpose of their work was to use the improved experimental and data reduction techniques developed in the few years prior to 1965 in order to obtain a calibration with the best data available. The report describes two test assemblies: "NOL Standardized Gap Test" [Fig 1(A)] and "Modified Gap Test" [Fig 1(B)]. The "Standardized Test", also known as "LSGT" (Large Scale Gap Test), is described in Refs 48 & 54. For description of "NOL Modified Test", see Refs 59 & 68. Other modification developed at NOL is described in Ref 52

In the procedure described in this rept,

the criterion of a "go" was a reaction of the acceptor energetic enough to punch a hole in the steel witness plate and it was required to have punctures in 50% of tests for each length of gap in order to declare the results "positive". From the measured 50% gap and a calibration curve of peak shock pressure as a function of length of shock travel thru the gap material, the shock pressure at the end of the gap was determined. This result was used with the pressure-particle velocity relation for the shocked (but unreacting) test explosive to determine the critical initiating pressure for detonation, ie the pressure transmitted thru the 50% gap in the standardized donor/gap system

In order to study "sub-detonation reactions" and at the same time to take advantage of the available calibration information, the standardized test is modified as shown in Fig 8 reproduced from NOLTR 64-53 (Ref 59). Although this test retains the standardized donor/gap system, its acceptor is unconfined and much shorter. Chemical reaction is desurveillance of the acceptor. Burning is evidenced by the break-out of gaseous products. The curve for time of break-out (time of shock arrival at free surface to time gas is observed) can be extrapolated to give the critical pressures just to initiate the burning

Detailed description of "calibration procedure" is given on pp 4-26. Fig 2A, p 6 (not reproduced here) illustrates the "Test Set-Up for Obtaining the Shock Velocity with a Smear Camera" and Fig 3A, p 8 "Smear-Camera Set-Up for Measuring Free-Surface Velocity", "Summary and Conclusions" are given on pp 24-6 and Refs on pp 27-8 of the report

59) T.P. Liddiard & S.J. Jacobs, "Initiation of Reaction in Explosives by Shocks", **NOLTR 64-53** (1965). The "Modified Gap Test", illustrated here in Fig 8, is identical with the test arrangement described in Ref 58, except that two charge set-ups were used in order to conserve light sources. A

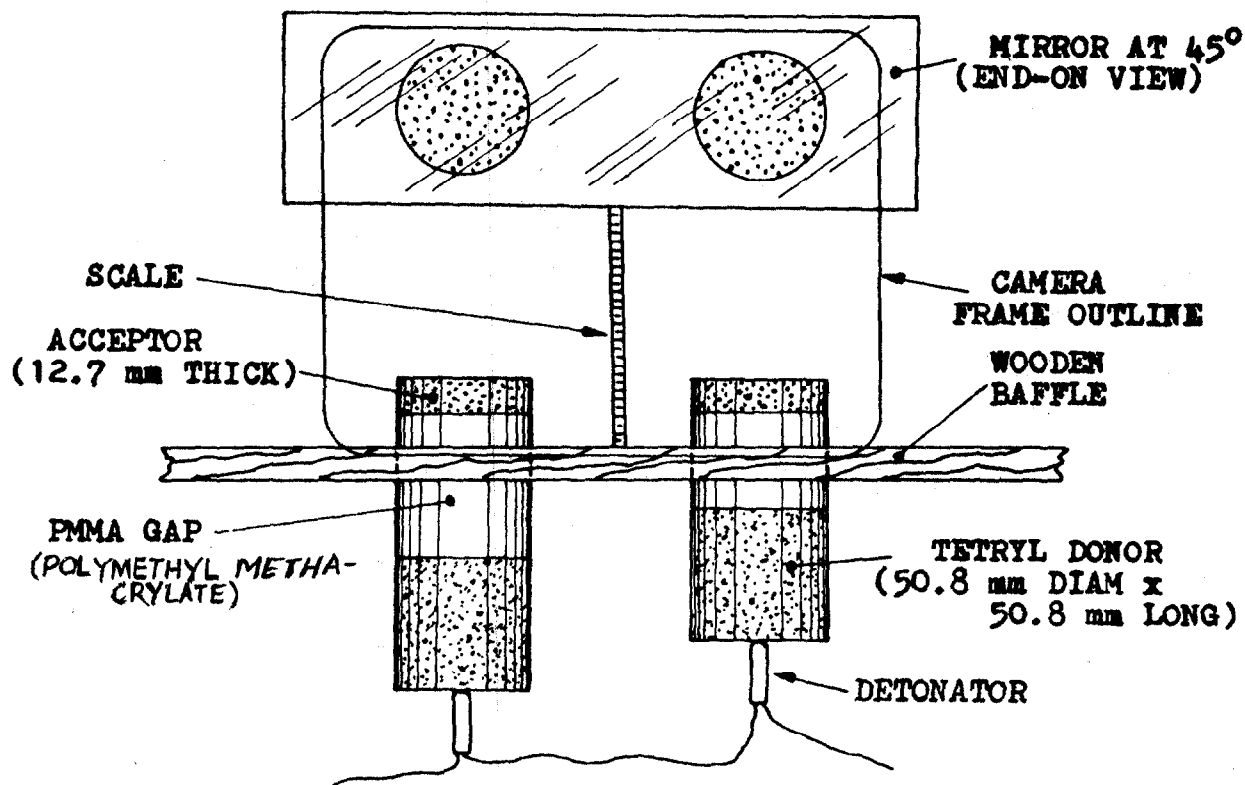

FIG 8 NOL MODIFIED GAP-TEST ARRANGEMENT

High-Speed Focal Plane Shutter Framing Camera was used in connection with this gap test arrangement to study initiation of reactions in explosives by shocks of moderate amplitudes. Appropriately placed mirrors provided an end-on view of the acceptor

As can be seen in Fig 8, the acceptors were much shorter than in "Standardized Gap Test", described in Ref 48 and they were unconfined. Results of critical gap (50% point) tests have shown that shock pressure of ca 10 kbars will build-up to detonation in sensitive expls such as pressed Pentolite, Comp B-3 or Tetryl, while a pressure of 40 kbars was required for build-up in insensitive expls like cast TNT. Smaller pressures (1 to 5 kbars) are required to produce fires, deflagrations or nondetonating explosions. Results of tests are given in Tables 1 and 2 of the report, which are not reproduced here

60) I. Jaffe et al, "The NOL Large Scale

Gap Test, Compilation of Data for Propellants and Explosives II", NOLTR 65-177 (1965) (Conf) (Not used as a source of information)

61) G.D. Dorough et al, "The Susan Test for Evaluating the Impact Safety of Explosive Materials", LRLR UCRL 7394 (1965) (For description of Susan Test see Ref 67)

62) M.C. Chick, "The Effect of Interstitial Gas on the Shock Sensitivity of Low Density Explosive Compacts", 4th ONRSympDeton (1965), pp 349-58 [A small scale gap test, briefly described on pp 350-51, has been used to investigate the role played by interstitial gases in the shock initiation of granular cylindrical charges of HMX ($\rho = 1.14$ g/cc with 40% voids) and PETN ($\rho = 0.90$ g/cc with 49% voids) serving as receptors. Serving as a donor was a compressed PETN pellet of diam 0.23 inch, weighing

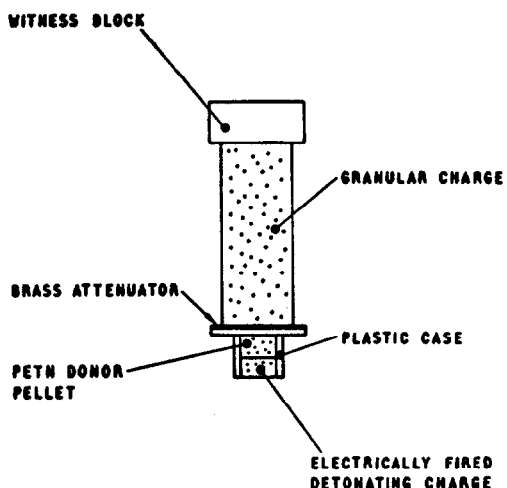

Fig 9 Gap test assembly

0.25 g. Its density was 1.68 g/cc and it was placed in a plastic case. The gap test assembly, shown in Fig 2 of paper, is reproduced here as Fig 9. Granular charges of HMX & PETN were prep'd in brass telescope tubing 3.0 inches long and 0.74-inch OD and 0.719-inch ID. Its bottom end was closed by a square brass shim 1.0 x 1.0 x 0.006 inch using a minimum of solder. Four symmetrically placed 0.020 inch diam holes were drilled 0.0625 inch from the base of the tube to ensure that the gas entered the tube after being placed in the pressure vessel. As a barrier (attenuating gap), a stack of 0.002 inch brass shims was placed between donor and receptor. The pressure vessel described on p 350 of paper is shown here in Fig 10. After inserting the gap test assembly, the pressure vessel was flushed with a gas used in the test, such as air, CH_4 , CO , H_2 , N_2 , CO_2 , etc. Then the vessel was sealed and the gas pumped in to desired pressure, which was as high as 1000 psi. For experiments at 1 atm, the vessel was pressurized to 100 psi, left for 5 mins, exhausted, repressurized and finally depressurized to 1 atm. After each firing (by means of an electric detonator), the steel "witness block" placed on top of gap assembly was examined for the characteristic impression formed on it, which

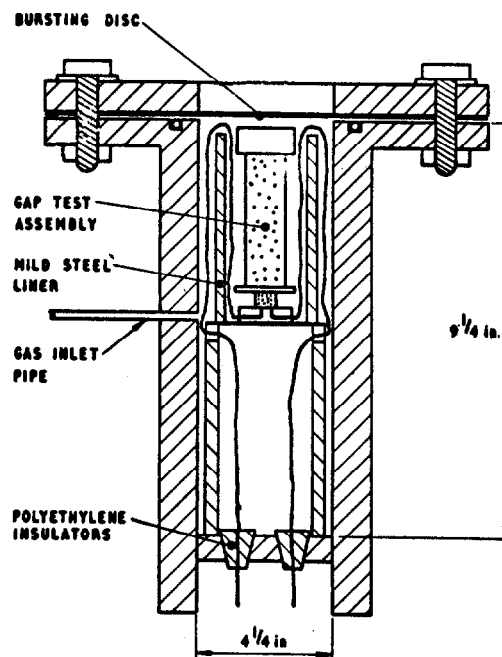

Fig 10 High pressure vessel with gap test assembly

signified detonation. For each test 20 chges were fired using the "Bruceton staircase procedure" to determine the shim thickness required to produce detonations in 50% of the trials. Brass shim increments of 0.004-inch were used and the result was quoted as the "critical shim thickness" in thousands of an inch. Results for shock sensitivities for HMX and PETN in different gases were summarized in Tables 1, 2 & 3 of the paper and the relationships between 50% gap thickness and interstitial gas pressure were plotted in Figs 4, 5 & 6, not reproduced here. The results have shown that the shock sensitivity of HMX decreased as the pressure of gas was raised and similar, but less pronounced, effects were observed for PETN

The initial results were also reported in measurement of *detonation build-up* characteristics in coarse HMX compacts at density 1.14 g/cc in which the interstices were filled with methane. The experimental assembly for this test is shown in Fig 11. The brass container for receptor expl was of the same diam as in Fig 9, but it was 4.0 inches long. A series of probes, inserted

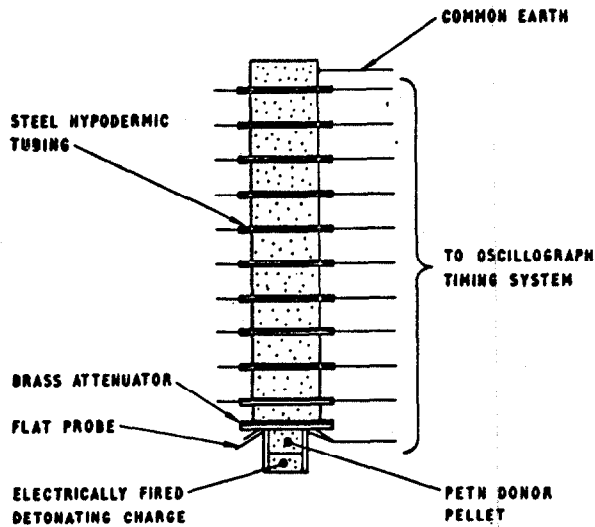

Fig 11 Build-up measurement assembly

across the column at ca 1 cm intervals, consisted of 31 SWG enamelled Cu wire sheathed in 0.028 inch OD stainless steel hypodermic tubing. On firing a PETN donor, the detonation front traveled thru receptor and, on reaching each probe, the wire was shorted to its sheath. This action was recorded by means of a high-speed oscillograph. The time of the emergence of the shock from the brass attenuator (barrier) was calcd from the record produced by a flat probe placed above the donor. The results from these tests are given in Tables 4 & 5 (not reproduced here) and the space/time relationships are plotted in Fig 12. Stable deton velocities were: 6.03 m/s ec for upper curve; 6.22 for middle curve, and av 6.225 for two lower curves which coincide with each other. This test has shown that pressure and nature of interstitial gas did not affect the high-order detonation velocity

63) J. Eadie, "The Effect of Wax on the Shock Sensitivity of Explosive Compacts", 4thONRSympDeton(1965), 399-403. Experiments were conducted using a "small gap test" apparatus similar to that described in 1958 by Cachia & Whitbread (See Ref 38). The assembly is shown here in Fig 13. The PETN pellet, B, was initiated by exploding wire assembly, A, which contained

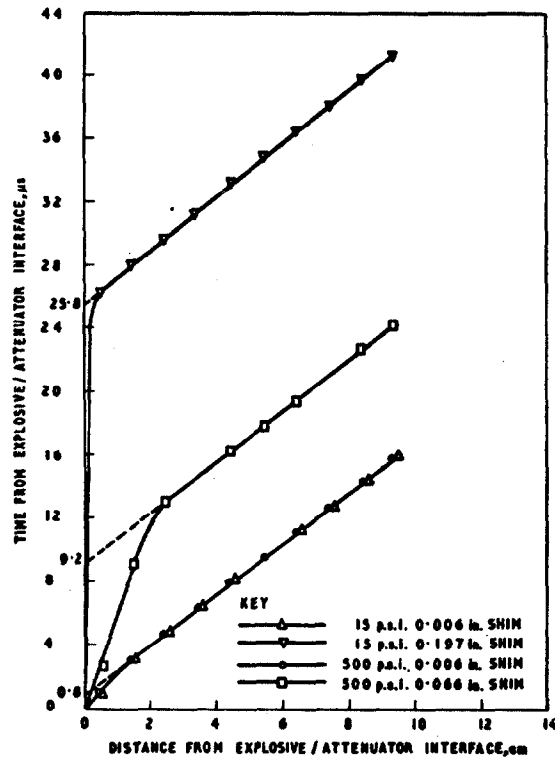
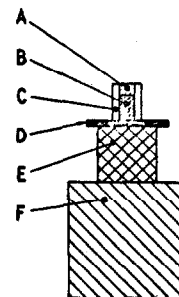

Fig. 12 Build-up to detonation in coarse HMX compacts at 1.14 g/cc filled with CH₄

powdered, low density PETN. This produced a standard shock which was attenuated to various extents by passing thru a stack of brass shims, D, which comprised the "gap"



- A=EXPLODING WIRE ASSEMBLY
- B=PETN DONOR PELLETT
- C=PLASTIC CASE
- D=BRASS ATTENUATOR
- E=ACCEPTON (TEST) CHARGE (1in. x 1in. CYLINDER)
- F=STEEL WITNESS BLOCK (2in. x 2in. x 2in.)

Fig 13 Gap test assembly

(barrier). The shims were in close contact with acceptor pellet, E, and when it was detonated a sharp dent was produced in witness block F. The gap thickness was varied accdg to the Bruceton "up and down" procedure and the results were quoted as the number of thousands of an inch of brass shim required to produce detonation of 50% of the samples. Crystals of HMX coated with various thicknesses of beeswax, candelilla wax and paraffin served as acceptors. Numerical results given in Tables 1 & 2, p 402 (not reproduced here) showed that coating significantly reduced shock sensitivity of HMX and provided evidence for the shock initiation of expls being due to a surface reaction. The results also showed that the actual surface area of the explosive exposed is important. The number, surface area or volume of the voids between the particles also affect the shock sensitivity of an expl chge, but they do so only insofar as they affect the exposed surface area of the explosive

64) J. Savitt et al, "Direct Contact Detonation Sensitivity", 4thONRSympDeton(1965), 404-11. In the assembly illustrated in Fig 1, p 406 and reproduced here as Fig 14, the donor was an 8-inch long and 2-inch diameter column of NGu (Nitroguanidine) which was packed in 1-inch long increments into a cardboard tube which already contained at its bottom the acceptor (sample) assembly. The bottom of tube was placed on an Al witness plate, 0.5-inch thick, while on the top of pellets was placed a Tetryl booster (0.5-inch diam and 0.5-inch long) connected with a No 8 detonator and a safety fuse. Two types of sample loading were used. When wood confinement was employed, the sample was previously prepd in the form of short pellets 0.52-inch diam and these were inserted into a drilled hole of a wooden spool. When a metal confinement was required, the sample was loaded into a steel or Al tube 0.75-inch OD and 0.25-in ID, which was inserted into a wooden spool (See drawing beneath Fig 14). In both cases the sample was 1.03-inch long. For tests requiring

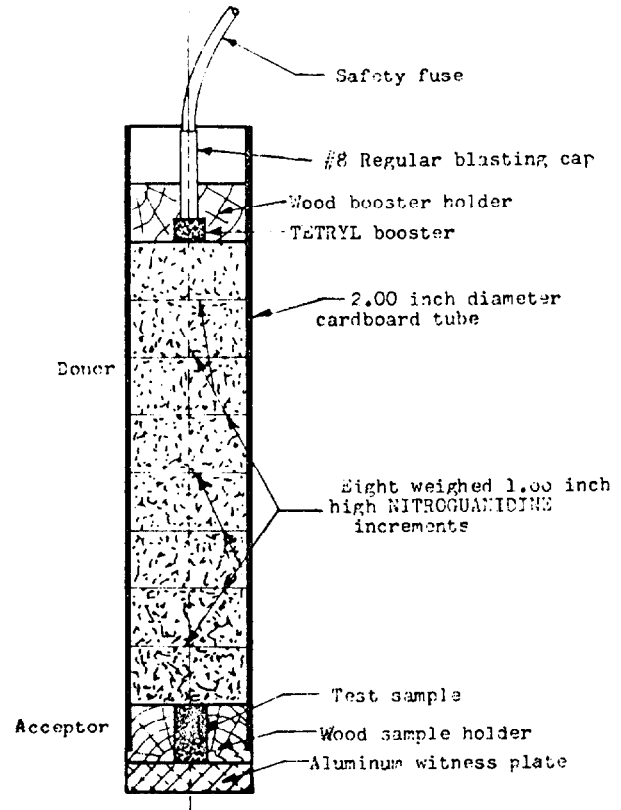
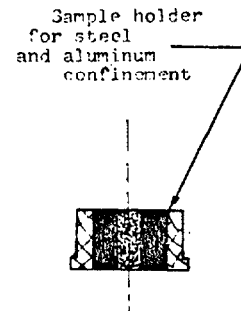

Fig 14 Direct contact detonation sensitivity test system



very high density-loading of NGu, the cardboard tube was placed, previous to loading, inside a steel container of the same ID as the OD of cardboard tube. This was done to prevent distortion of cardboard tubing during loading. A "Bruceton Type Staircase Procedure", described in NDRC Rept (See Ref 12a), with a donor density step size of 20 grains per inch long increment of NGu was used to determine the donor

loading density required for the 50% probability of high order detonation of the sample. The following expls served as acceptors: TNT, Tetryl, TNB and Explosives α , β & γ . The compositions of Explosives α , β & γ are not given. Results of the tests are given in Table 1, p 407 and in Figs 2, 3, 4, 5 & 6 of the paper. They are not included here. Of the three known expls, Tetryl showed the highest sensitivity, TNT the lowest, and TNB a sensitivity slightly lower than Tetryl

65) N. Lundborg, "Comparison Between Shooting and Barrier Tests", 4th ONRSymp-Deton (1965), 432-34. In the "shooting test", illustrated in Fig 15, an Al projectile, 15 mm in diam and length, travelled with velocity $v=650$ m/sec against a TNT sample of the same size. The upper part of Fig 15 shows the pressure-time diagram. In the "barrier test", shown in Fig 16, the explosion of the donor causes a shock wave in the barrier at the contact surface between the barrier and the explosive sample. The upper part of Fig 16 shows the pressure-time diagram for donor and acceptor, both of pressed TNT, and an Al-barrier 21 mm in diameter, at the critical length, 21 mm. The

pressure was not constant but fell rapidly with time. In both diagrams M signifies thousand (kilo) and p/cm^2 =pressure in bars

Tests conducted by Lundborg confirmed the results reported in 1961 by S.M. Brown & E.G. Whitbread (See Ref 50a). These results showed the existence of a linear relationship between the critical length of barriers and the critical velocity of projectiles. Besides using pressed TNT as a sample, Lundborg also examined cast TNT and pressed PETN+10% wax. In Table 5 are given the critical lengths of Al barrier at which detonation of sample is produced on explosion of donor charge of TNT and also the lowest (critical) projectile velocity values to produce the same results in shooting tests

Table 5

| Explosive | State | Density g/cc | Barrier Length, mm | Projectile Velocity m/sec |
|----------------|---------|--------------|--------------------|---------------------------|
| TNT | Cast | 1.60 | 3-4 | 1500-1720 |
| TNT | Pressed | 1.54 | 20-21 | 640-650 |
| PETN + 10% Wax | Pressed | 1.33 | 28-29 | 290-340 |

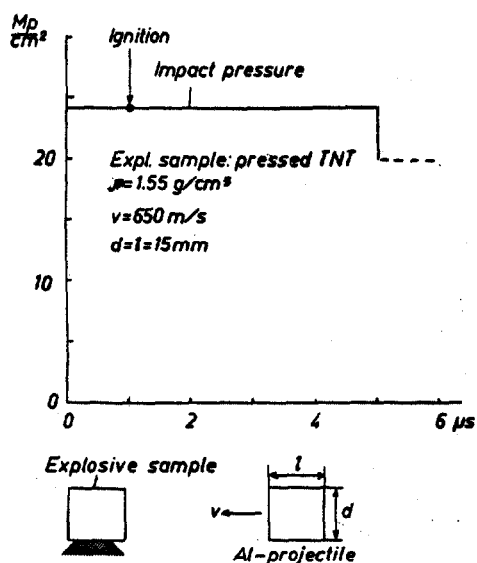

Fig 15 Shooting test

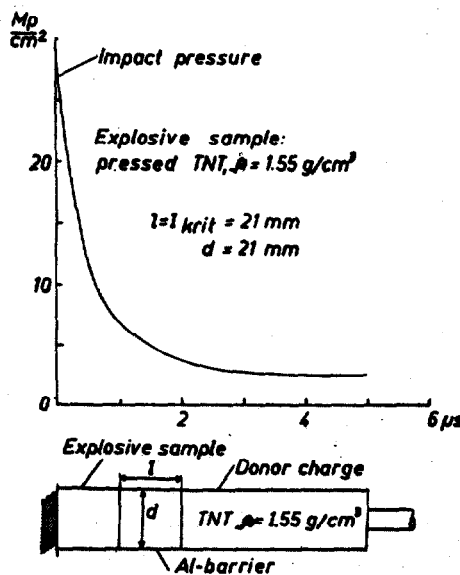

Fig 16 Barrier test

In order to be able to interpret these results, it is necessary to know the end velocity of Al barrier; corresponding to its various lengths. Following values are extracted from Table 2, p 434 of paper: 1890 m/sec for barrier length 5 mm, ca 700 for 21 and 410 m/sec for 31 mm. All these values are slightly higher than corresponding shooting test velocities recorded in Table 5. The conclusion is that the barrier test demands a somewhat higher velocity than the shooting test for the same explosive

66) N. Griffiths & V.C. Broom, "Low Order Reactions in Shocked Explosives", 4th ONR-Symp Deton (1965), 462-72. Experiments described in the paper were conducted with a view toward improving the existing systems for the disposal of HE filled bombs. In these experiments the initiation of RDX/TNT, Torpex and Minol in Gap-Test type devices has been studied and emphasis has been placed on producing events other than high-order detonation

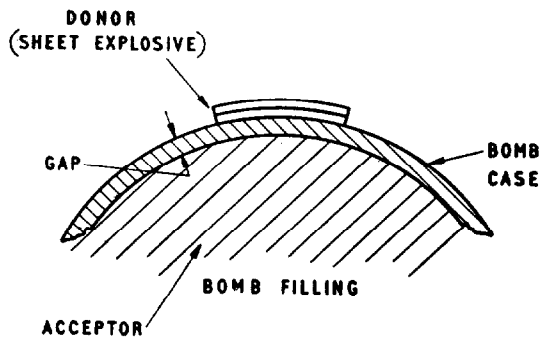

Fig 17 Bomb disposal gap test

In Fig 17 is illustrated a test in which a sheet explosive (donor) was detonated on top of a bomb case filled with one of the above HE's, serving as acceptor. The bomb case served here as a gap and it was possible to produce in the HE, under certain conditions, a low-order reaction instead of detonation

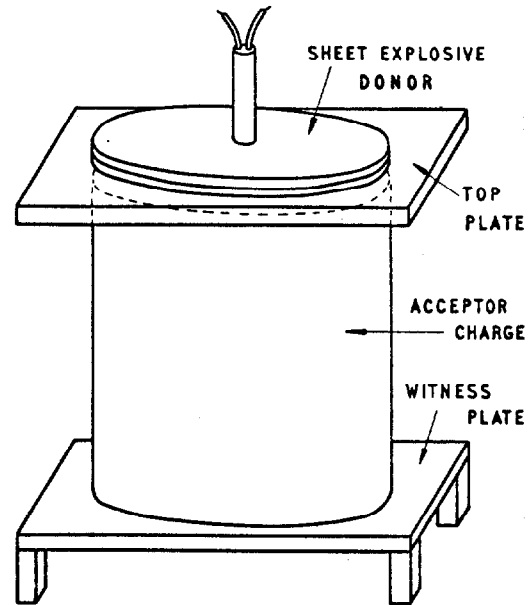

Fig 18 Perpendicular gap test arrangement

In Fig 18 is illustrated an arrangement employing a circular donor of sheet expl (RDX in a thermoplastic matrix), as a gap a 6x6-inches mild steel plate (of thicknesses varying from 1/8 to 1/2 inch), and as acceptor chges Comp B, Minol 2 and Torpexes 2B & 4B. An ASA Briska Electric Detonator served for initiating the donor and as a witness plate a mild steel plate, 6x6x1/8 inches. The order of the reaction in the acceptor was estimated by assessing the damage to this plate

In Fig 19 is shown an arrangement using a curved surface similar to those encountered in bomb or shell walls. A donor chge of sheet expl was placed on a mild steel cylinder of ID 4-in, wall thickness 0.5-in and length 8-in. Acceptors and detonator were the same as in Fig 18. In designing this test, attempts were made to take into account the effects of rarefaction waves, and it was likely that with the dimensions chosen, they would have little effect on the reaction zone during the critical time in which the probability of detonation occurring was being determined

The results showed that by carefully adjusting the donor chges and the thickness

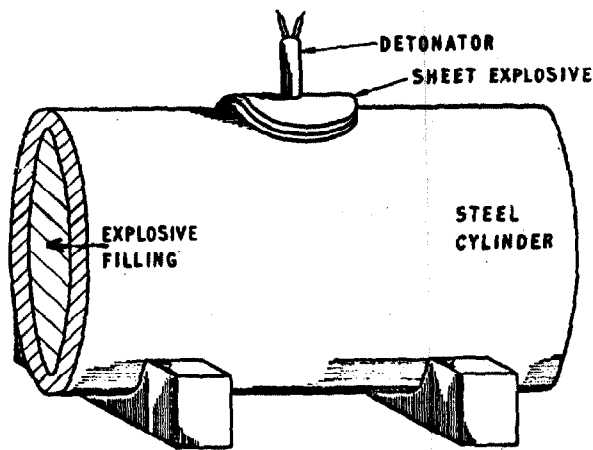

Fig. 19 Cylindrical gap test arrangement

of gap, it was possible to produce low-order reactions instead of detonations. A detailed discussion of results is given on pp 465-72 of the paper

66a) H.S. Napadensky, "Initiation of Explosives by Low Velocity Impact", 4th-

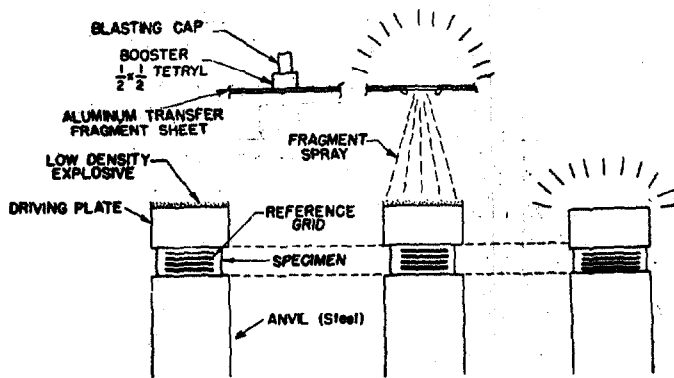

Fig. 20 Test arrangement showing method of initiating driver explosive

ONRSympDeton(1965), 473-76. A sensitivity test illustrated in Fig 20 deals with cylindrical, unconfined HE samples of the order of several pounds in weight, squeezed between an explosively propelled steel plate (6 inches in diameter) and a steel anvil. For driving the plate, a chge of low density Tetryl was spread on its surface. The initiation was accomplished by the fragmentation of the Al disk, which occurred when Tetryl booster was ignited by a blasting cap. The

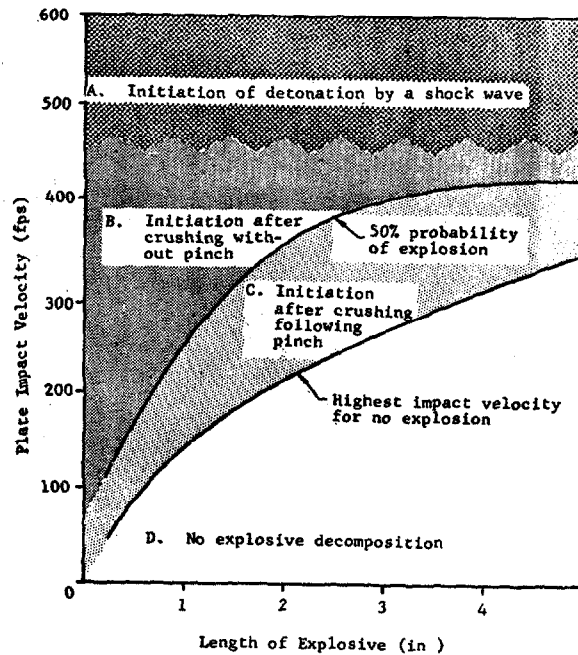

Fig. 21 Critical impact velocity as a function of explosive length, for 6-inch diameter 9404 PBX billets impacted by 6-inch diameter by 1-inch thick steel plates

fast-flying hot Al fragments hit Tetryl expl in a large number of places almost simultaneously and caused its detonation and movement of plate with uniform acceleration. Using Tetryl pdr of density 1 g/cc a velocity of 1000 fps was obt'd, while Tetryl of 1.2 g/cc produced 2000 fps. By varying the quantity and density of Tetryl it was possible to achieve velocities from 25 fps to 2000 fps

It was found that the impact velocity of the steel plate required to initiate an explosion reaction depends upon the dimension of the sample. For a fixed diameter, the minimum impact velocity increases with increasing length, but rapidly approaches an upper limit which is sufficient for shock initiation of the explosive. The upper limit decreases with increasing diameter. A limit diameter is also reached beyond which any further increase in diameter will not lower the critical impact velocity

Some numerical data are given for Tritonal, H-6 and 9404 PBX explosives. As an example the Fig 21 (p 474) is shown here

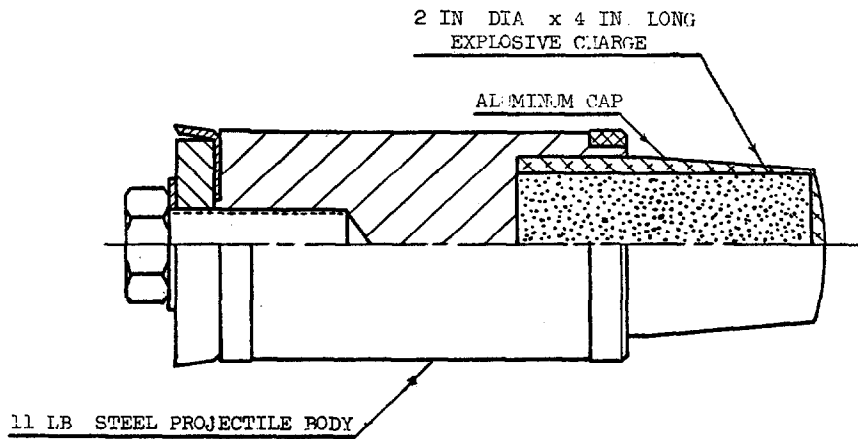

Fig 22 Mod I Susan projectile

67) L.G. Green & G.D. Dorough, "Further Studies on the Ignition of Explosives", 4th ONRSympDeton (1965), p 477-86. Experiments were carried out by means of the "Susan Test", which was previously described by Dorough et al (See Refs 55a and 61). In this test is investigated the ignition of explosives by low velocity crushing impact. In Fig 22 is shown the projectile used in the test. It is fired from a smooth bore gun against a steel target at velocities from 100 to 1500 fps. The chemical reactions produced by the impact are monitored photographically with Fastax cameras; air shocks generated by the re-

acting explosive charge are monitored with overpressure gauges. Addnl info is also obt'd from the physical examination of impacted projectiles

Fig 23 shows the deformation obt'd soon after impact. The end of the Al nose cap has opened up, but the longitudinal section of the cap has not yet split open. Fig 24 shows the deformation late in the impact. The Al cap has completely failed by longitudinal splitting, and the steel rim of the projectile body is in near contact with the target plate. This is called the "pinch stage" and the most violent reactions from a Susan type impact

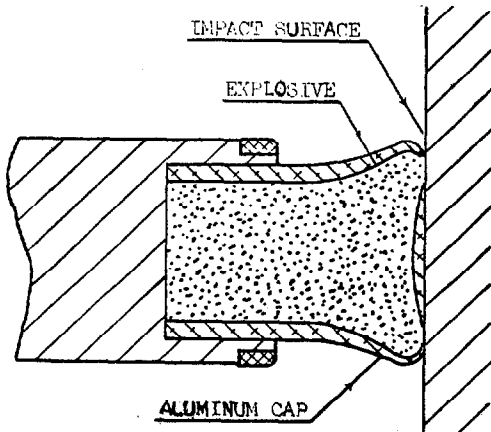

Fig 23 Mod I Susan projectile early deformation

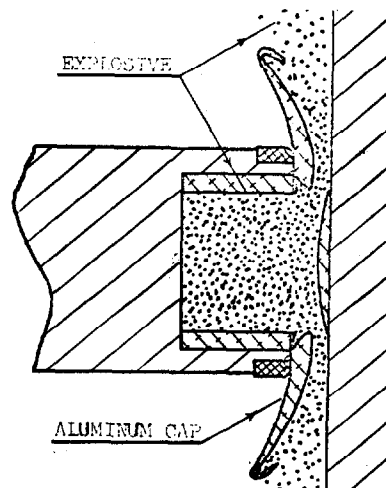

Fig 24 Mod I Susan projectile pinch stage

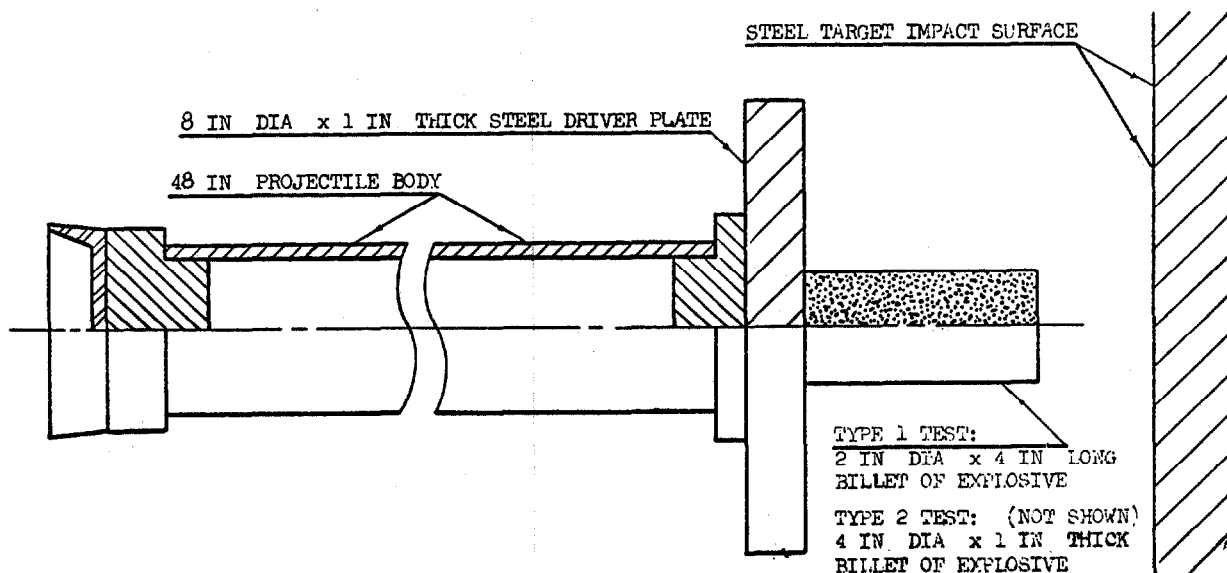

Fig 25 Muzzle-loaded projectile for Type 1-Type 2 tests

almost always occur at the pinch stage. About 30 expl formulations examined were observed to ignite or deflagrate under pinch conditions, but detonations were only rarely (if ever) observed

For comparison with Susan Test, Fig 25 shows variations of an "anvil-driver impact test" first described by Napadensky et al (See ref 42a). As conducted by Green & Dorough, the driver plate was a mild steel plate, 8-inch diameter & 1-inch thick and the target (anvil) a 10-inch square plate of mild steel. The driver plate was attached to one end of a 4-foot long iron tube, which was closed at the other end with a pressure seal. A Susan-type projectile (billet) was lightly glued to the center of plate. The tube was inserted in the muzzle of a smooth bore gun and fired down a short range with a propnt chge sized to attain terminal driver-plate velocities in the range of 80-400 ft/sec. In the Type I Test, an expl billet 2-inch diam & 4-inch long was used while in Type 2 Test the size of billet was 4-inch diam & 1-inch long. The main diagnostic tool used in both Type 1 & Type 2 experiments was a high-speed camera framing at the rate of ca

There is a difference between Susan and

Type 1-Type 2 tests. Whereas the Susan Test is a quick and reliable way of obtaining a comparative assessment of an explosive's behavior under impact, the Type 1-Type 2 experiments provide a way of elaborating on that behavior but at the cost of a considerably larger number of experiments than that required for the Susan Test

Test results for expls Comp B-3, LX-04-1, RBX-9404-02 and PBX-9404-03 are given in Tables 2, 3 & 4, pp 482-84 of paper, but they are not reproduced here

68) T.P. Liddiard, Jr, "The Initiation of Burning in High Explosives by Shock Waves", 4thONRSympDeton(1965), 487-95. This paper is concerned with experimental studies of the initiation of chemical reactions by mechanical shocks of low amplitudes. For the first series of experiments the "NOL Modified Gap Test" similar to that of Ref 59 was used (See Fig 26). The results showed that typical burning of HE's is sufficient to produce a stress of 10-25 kbar, which is about one-half the stress needed to build-up to detonation. The results confirmed the findings reported in more detail in Ref 59. These thresholds of burning are high compared to those estimated for the "Skid Test"

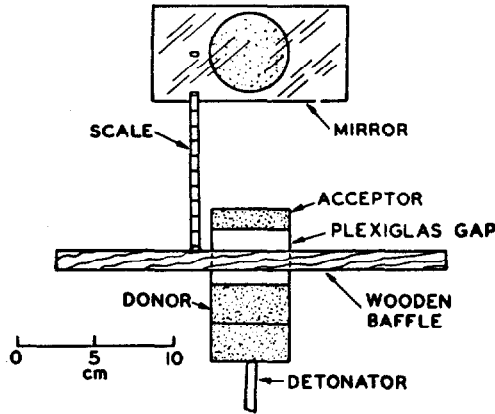

Fig 26 The modified gap test

(Ref 55b) and for the "Susan Test" (Refs 55a, 61 & 67). It was of interest to determine if the above threshold can be lowered by applying shocks of longer duration and more nearly plane as used in the NOL modified gap test. In this test the pressure falls rapidly because of the action of strong rarefaction waves and in addition, the shock entering the explosive is quite curved. An experimental arrangement which gives a more nearly 1-D shock front and a longer more predictable duration was carried out in a large tank of water using a spherical donor. Such an arrangement was first employed in 1949 by Eyster et al (Ref 19) and later by Winning (Ref 38a). The arrangement described by Liddiard is similar to that of Winning (See Fig 27). It consisted of spherical Pentolite (1 lb), serving as a donor, held in a harness of nylon thread and four acceptors of the same size as used in the modified gap test described in Ref 59. Pairs of thin, 6-mm

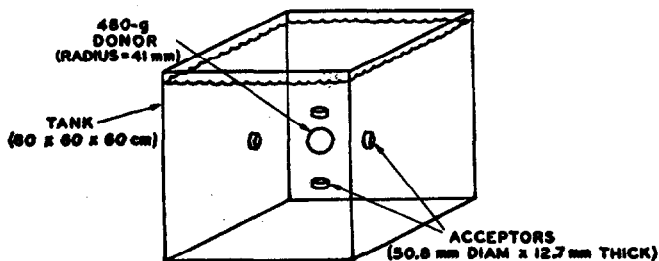

Fig 27 The underwater system

wide polyester tapes held the acceptors securely at their cylindrical surfaces. The axis of the detonator for the donor was located in a position normal to the plane of the acceptors. All these items were mounted in a frame and then the assembly was submerged in a 60 x 60 x 60-cm tank of water. Observations were made with the Jacobs focal plane shutter camera which is described in Ref 56d. Diffuse reflected back-lighting was obtained by an argon flashlamp which illuminated a white cardboard in back of the tank

As acceptors used in underwater tests were 50/50-Pentolite, TNT, 60/40-Cyclotol, PBX 9404-03 and LX-04-1. The results gave thresholds for burning which are comparable in magnitude to Susan and Skid tests, but lower than those obtained by the modified gap test. This showed that burning can be produced at lower shock levels if the pressure were held longer and the wave front made flatter

In Table 6, reproduced from p 494 of the paper, the pressures, P_b , of shocks required to produce burning just detectable in underwater test and modified gap test are compared

Table 6

| Explosive | Loading Density g/cc | P_b Under-water, kbar | P_b Mod Gap, kbar |
|----------------|----------------------|-------------------------|---------------------|
| Pentolite | 1.67 | 3 | 10 |
| 60/40-Cyclotol | 1.70 | 4 | 13 |
| PBX-9404-03 | 1.83 | 5 | 16 |
| TNT | 1.62 | 8 | 23 |
| LX-04-1 | 1.86 | 9 | 23 |

69) W.L. Murray & J. Plant, "A Method for the Study of Solid Explosives and Other Solid (Including Porous) Materials When Subjected to Shock Waves", 4th ONRSympDeton (1965), 355-65. Description is given of a method for determining simultaneously the pressure, density and velocity in shock waves in solid (including porous) materials. The shock was produced in a cylinder of material using the solid "barrier" technique which is usually

employed for testing the sensitivity of expls to shock initiation. The velocity of the shock was detd by using "schlieren photography" to detect its time of arrival at small holes bored in the material and the particle velocity was found from the velocity of the shock wave produced in air at the free end of the material. The method was used to investigate the critical shock pressures required to initiate detonation in two coal mining expls contg NG, AN, cellulose and inerts including NaCl and Ba sulfate. Results are tabulated and plotted as curves

70) C. Peyre et al, "Experimental Method for Analysis of the Structure of a Shock Wave in a Solid", 4thONRSympDeton(1965), 566-72. The principle of the device used in the experiments (See Fig 28) consisted in making a plane shock wave, generated by an expl charge, propagate in a metallic base plate (platform). A prism of the solid to be studied was attached to the plate. The free surface of prism was polished so that it could reflect at S_1 the virtual image of a luminous source, S . During the passage of the shock wave, the free surface of prism which is reached obliquely underwent a rotation α

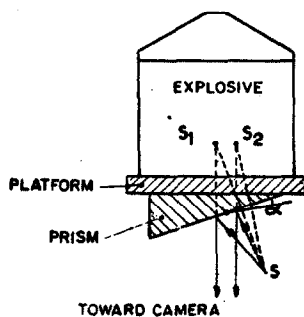

Fig 28 Diagram of the principle

and the image of S was displaced to S_2 . If the shock wave had a complex structure, it produced successive rotations of the free surface, and positions $S_2', S_2'' \dots$ of the image S could be recorded with a "streak camera" as a function of time. The measurements of the displacements $S_1 S_2, S_1' S_2'$, etc per-

mitted one to determine the rotations $\alpha, \alpha' \dots$ and the pressures of the successive shock waves

This method also permits one to observe directly on the film the discontinuous aspect of shock phenomenon and it can be used to observe elastic precursors in weak shocks, to analyze changes of state, and to investigate the causes of shock-wave doubling

71) E.G. Johnson, "A Microwave Technique for Studying Detonation Phenomena", 4th-ONRSympDeton(1965), 584-94. The microwave technique previously described in Refs 17a and 38b was used in modified form at Redstone Arsenal Research Division for studying shock phenomena in condensed phases. The microwave energy reflected by the shock front was used to determine velocities of both reactive (detonation) and nonreactive shocks. In the schematic diagram of instrumentation shown in Fig 29, the function of klystron was to generate the microwave energy, the attenuator was used to adjust the power level, the frequency meter to determine the microwave frequency, the directional coupler to separate the transmitted from the reflected energy and was oriented in the transmission line to pass the reflected energy. The crystal detector was used to monitor the reflected energy passed by the directional coupler and converted the reflected microwave energy to a voltage. An oscilloscope and a camera were used to record the output voltage of the crystal detector. The oscilloscope was triggered from the ionization switch probe by the detonation and a dielectric rod waveguide (such as described in Ref 18a) was used as a transmission line between the instrumentation and the sample. The dielectric rod waveguide was expandable and acted as a mode selector to launch a pure mode of transmission in the sample. The location of sample, detonator and ionization switch are shown in Fig 30. The standard rectangular waveguide from the instrumentation shown in Fig 29 was converted to circular waveguide by a transition. A polystyrene rod

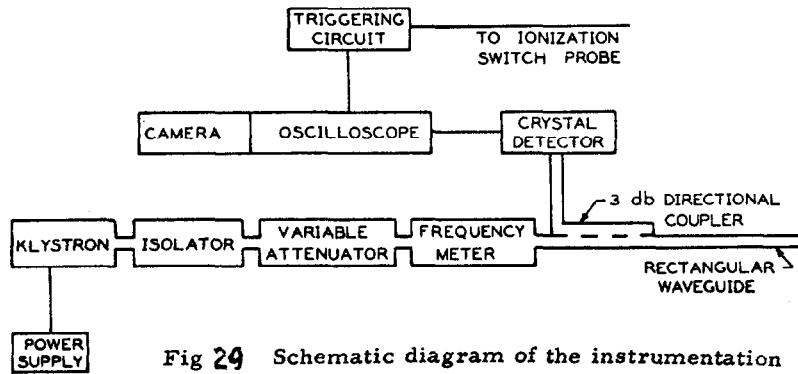

Fig 29 Schematic diagram of the instrumentation

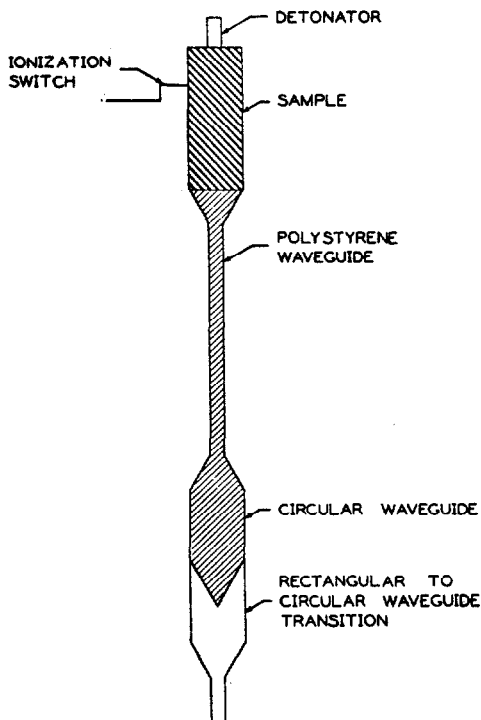

Fig 30 Schematic diagram of the experimental setup

tapered to a point to reduce reflections, was inserted a short distance into the circular waveguide. The polystyrene rod was then tapered to a small diameter rod (to reduce losses in transmission) and then expanded to the diameter of the sample

The voltage developed in the crystal detector can be considered as the sum of two reflected microwave signals. One is the sum of all fixed reflections in the trans-

mission line and is of constant phase. The other is the reflection from the shock front and goes thru a 2π phase shift for each displacement of the front by a half wavelength of the microwaves. Thus the voltage from the crystal detector goes thru a maximum and minimum for each displacement of the shock front by a half wavelength

In terms of the Döppler effect [discovered in 1842 by C. Döppler (1803-1853)], the frequency of the voltage from the crystal detector can be considered as the Döppler shift in frequency f_d given by

$$f_d = \frac{2vf}{c'}$$

where v is the velocity of the reflecting shock front, f is the microwave frequency and c' is the velocity of propagation of the microwaves in the medium thru which the shock travels

The wavelength of the microwaves in the sample was usually determined by observing the number of peaks in the voltage from the crystal detector as the shock front traversed a sample of known length. When multiple modes of propagation were present in the sample, the voltage from the crystal detector appeared modulated because the modes had different wavelengths

For determination of growth to detonation in expls as acceptors: AP (Ammonium Perchlorate), Comp C-4, and Pentolite were used and as donor charges Pentolite pellets. As barrier (gap) material Plëxiglas disks were used

In examination of Pentolite, the following values were determined: Plexiglas gap, Time to detonation, Distance to detonation, Final velocity in Plexiglas and Initial velocity in acceptor. For example, for gap 0.798 inches, Time to detonation 2.5 μ sec, Distance 8.8 mm, Final vel in Plexiglas 3.8 mm/ μ sec, Initial vel in acceptor was 3.4 mm/ μ sec. Other values were 0.812 in, 4.4 μ sec, 15.0 mm, 3.9 mm/ μ sec and 3.5 mm/ μ sec, respectively

In comments to the paper of Johnson, C. Fauquignon stated that a similar use of microwaves in time resolved interferometry was developed in the laboratory of the Commissariat de l'Énergie Atomique, France (p 594)

72) B. Hayes, "On Electrical Conductivity in Detonation Products", 4thONRSympDeton (1965), 595-601. Investigation discussed in this paper has shown that the electrical conductivity of detonation products for different expls ranges from 1 to 10^4 mhos per meter. A strong correlation between the value of the peak conductivity and the calculated carbon content in the detonation products was noted. This means that in expln products contg free C, the conductivity is mainly due to the fractional solid C density in the products. In deton products not contg free C, the electrical conductivity is low and conduction is primarily due to ions which are formed because of high temperatures developed on detonation

73) Per-Anders Persson et al, "A Technique for Detailed Time-Resolved Radiation Measurements in the Reaction Zone of Condensed Explosives", 4thONRSympDeton (1965), 602-08. Preliminary experi-

ments with nonporous 60/40-RDX/TNT and NMe (Nitromethane) using a fast photomultiplier and high-speed oscilloscope are described. The technique permitted recording of the intensity of light emitted from within reaction zone of some expls. A light from a thin translucent disk of expl in contact with the end surface of a cylindrical chge

of the same expl was recorded while the deton wave travelled across the thickness of the disk. A very thin layer of opaque material was used to screen off the light from the main chge

In these tests NMe showed the detonation-to-shock and shock-to-detonation transition characteristic of a homogeneous expl even with barriers as thin as 25 μ . The reaction zone had a peak of probably less than 10 μ thickness. Nonporous 60/40-RDX/TNT was less sensitive to disturbance by thin barriers than NMe. A 250 μ thick barrier could cause a disturbance in the reaction, but there was no delay and very little overshoot of the type usually associated with homogeneous expls. Experimental arrangements shown in Figs 1, 2, 3, 4 and 6 are not reproduced here

74) J.R. Travis, "Electrical Transducer Studies of Initiation of Liquid Explosives", 4thONRSympDeton (1965), 609-15. For one-dimensional shock initiation of liquid explosives, the following thermal explosion model was found to incorporate adequately most of the exptl observations. A plane shock wave entering a liquid expl compresses and heats it. After an induction time during which chem reaction takes place, detonation in the heated compressed expl begins near the interface where the expl has been hot longest. This detonation travels as a super velocity wave thru the compressed expl, overtakes the initial shock wave, and overdrives a detonation in the unshocked expl. This overdriven deton decays to a steady-state deton in a few microseconds. If an expl is transparent such as NMe (Nitromethane), these events can be photographed with a "high-speed rotating-mirror smear camera". In the experiment shown schematically in Fig 31, the camera is aligned so that its slit subtends a diameter of the chge and its optic axis is congruent with the chge axis. As initiation takes place, the camera records light successively: 1) from the flasher when the shock wave enters the NMe, 2) from the detonation in the compressed expl, 3) from the strong interaction between this deton wave & the overtaken shock wave,

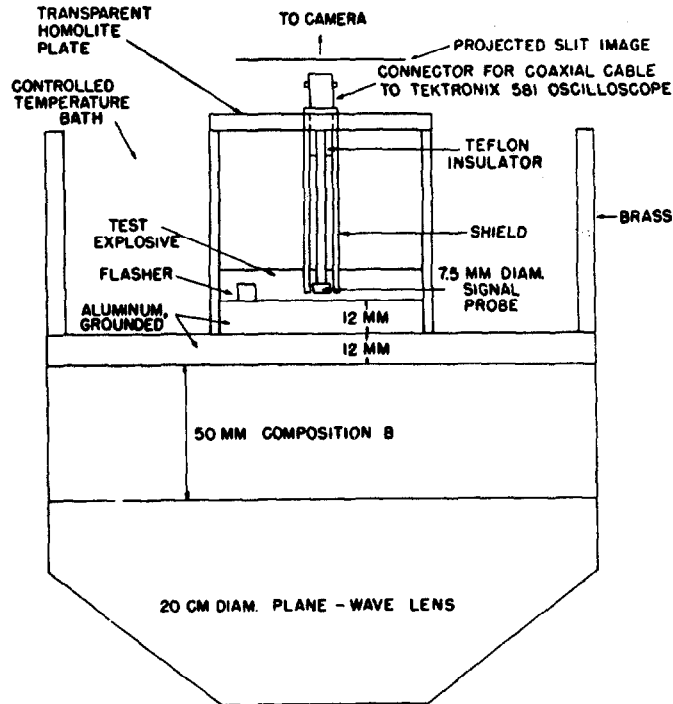

Fig 31 Schematic diagram of transducer mounted in a charge assembly. The probe shield is electrically connected to the grounded attenuator plate, to the wall of the explosive container, and to the ground lead of the signal cable

and 4) from the steady-state detonation in the unshocked explosive. In some expls (such as NMe), light from the supersonic detonation, although weaker than the light from steady-state deton, is readily photographed, while in others (such as Ditekite 13, 30/70-NMe or molten TNT) light from the supersonic detonation was never observed and the reason for this is unknown. In all other respects the initiation behavior of the above three expls is the same as that of NMe. If concn of TNT in NMe is lower than 20%, the luminosity from the supersonic deton is observed, but it occurs later in the time scale of the initiation process than it does in pure NMe

Since optical techniques could not be used to study events occurring within the opaque layers of liquid expls, a new method needed to be employed. A device called an *electric transducer* (a converter of electrical energy from one system to another, such as a transformer) was used by Travis in

LASL, Los Alamos, NM. The transducer described in his paper and shown in Fig 31 was in the form of an uncharged parallel-plate capacitor which had an explosive as a dielectric. One plate was connected to the signal input terminal of an oscilloscope, while the other plate was grounded and acted as part of the attenuator in the boosting system. When the shock wave in the grounded attenuator plate hit the explosive, a voltage appeared across the capacitor and a pulse appeared on the oscilloscope. Two oscilloscopes were used to record the waveform of the current in the transducer circuit which consisted of a small capacitance shunted by the small resistance of the signal cable. The design of the booster system was determined by the electrode spacing and was adjusted for each expl tested so that initiation would occur in less than one microsecond

As the output of an explosive filled transducer changed with time as the shock wave

proceeded thru it, the requirement was to correlate the previously described events occurring during initiation with the observed changes in the transducer changes. This correlation has been done for NMe, TNT/NMe, molten TNT and molten DINA (Dinitroxyethyl-nitramine) and this allowed Travis to perform experiments in which the transducer results could be combined with results from optical and other techniques to study some of the unsolved problems in the initiation of expls

75) L.D. Pitts, "Electrical Probe Technique for Measurement of Detonation and Deflagration Velocities", 4thONRSympDeton(1965), 616-26. In these experiments the probe consisted of a length of resistance wire sandwiched between two strips of insulating material. After placing the probe adjacent to the wall of the metallic test cylinder, a constant current was forced thru the probe. Detonation, or deflagration front pressure

forced the resistance wire thru the insulation, and a decreasing voltage, inversely proportional to the distance of the front from the initiated end, was registered on an oscilloscope. A schematic view of experimental setup is presented in Fig 32

Using the electrical probe technique, detonation velocities of PETN pressed to various densities and deflagration velocities of various pyrotechnic mixtures were determined. The charges were confined in cylinders of 0.100-inch ID and 1.25-inch length. Numerical values are listed on pp 623-25 of the paper

77) Jean Crosnier et al, "Anomalous Thermoelectric Effect in the Shock Regime and Application to a Shock Pressure Transducer", 4thONRSympDeton(1965), 627-38. When a shock wave crosses the junction surface of two metals of different natures (arranged like in a thermocouple) there appears between the uncompressed extremities of the

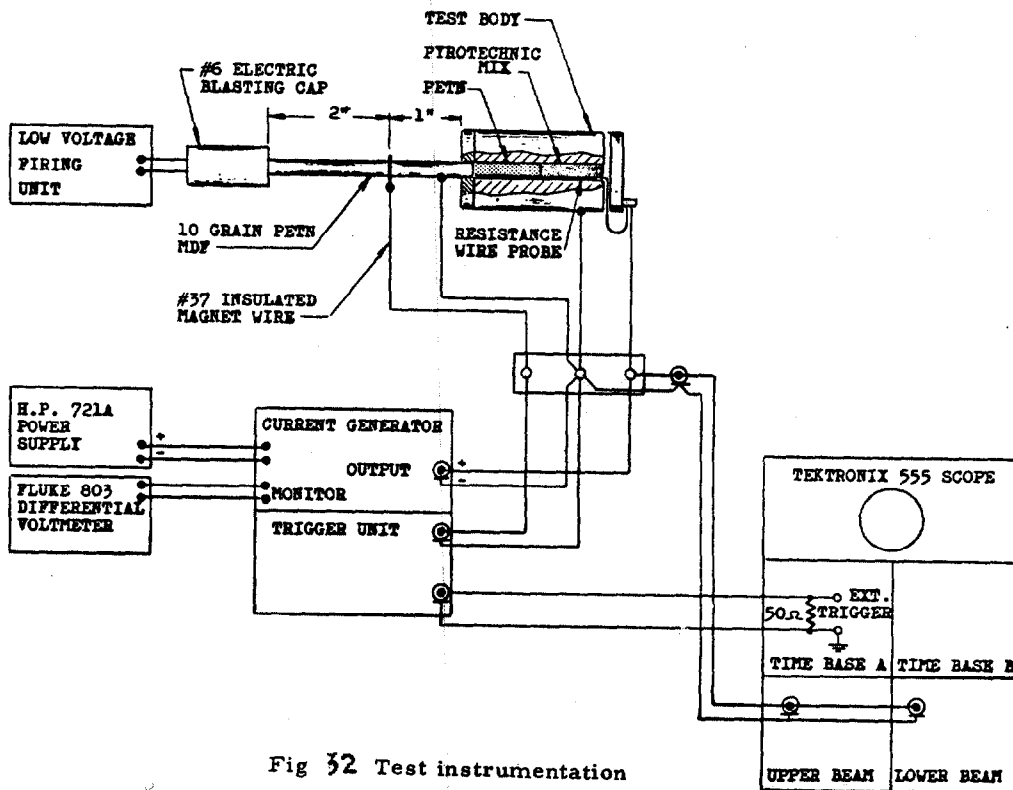

Fig 32 Test instrumentation

metals a difference in potential, the magnitude of which is dependent on the amplitude of the shock wave and the nature of the metals in contact. This effect was first noticed in 1959 by J. Jacquesson of France and later by others during the investigation of a thermal electric detector for the recording of temperature at the front of a shock. In the exptl study of the electrical response of thermocouples made by Crosnier et al with different metals, when they were put into shock loaded metallic samples, it was shown: 1) That in respect to several physical aspects they behaved like static thermocouples and 2) That the response seemed to increase with pressure up to at least 1600 kbars and is of such large magnitude that any classical interpretation appeared impossible

This effect was used to detect and measure shock pressure in metallic targets, provided that certain requirements were fulfilled

Several theories to explain this effect were proposed. One of them attributes the effect to the formation of an electronic hot gas, the temperature of which would be much higher than that of the crystal lattice

Experimental arrangements are given in Figs 1, 2, 4, 5, 7 and 9 of paper and not reproduced here

Utilization of this effect to make a pressure transducer for shock measurements was described on pp 636-37 and illustrated in Figs 15 & 16 of the paper. Illustrations are not reproduced here

Results of tests were considered by Crosnier et al to be preliminary

78) D. Venable & T.J. Boyd, Jr, "PHERMEX Applications to Studies of Detonation Waves and Shock Waves", 4thONRSympDeton(1965), 639-47. PHERMEX is a 20-MeV, high intensity, high current flash radiographic machine which has been built to complement other hydrodynamic facilities of the Los Alamos Scientific Laboratory, Univ of California, Los Alamos, New Mexico. A schematic diagram of PHERMEX is given in Fig 33. The main part of PHERMEX is its accelerator system which consists of three cylindrical copper-lined cavities, ca 4.6 meters in diameter and ca 2.6 m long. Each cavity contributes ca 7 MeV to the injected electrons. The electron beam ejected from thermionic cathode in the electron gun, pass thru injector lens into accelerator cavities and from there is focused upon a 3-mm diam aperture in a thick Be collimator. After emerging from it, the beam passes thru a 0.5 mm thick Be window and falls on a 1-mm thick tungsten target, which is located ca 10 meters outside of reinforced concrete housing, which provides protection for PHERMEX from blast or shrapnel

Fig 34 represents schematically a radiographic geometry used for many of the experiments described in the paper. Two Al conical cassettes are shown in Fig 2. One serves to protect the target, while the other

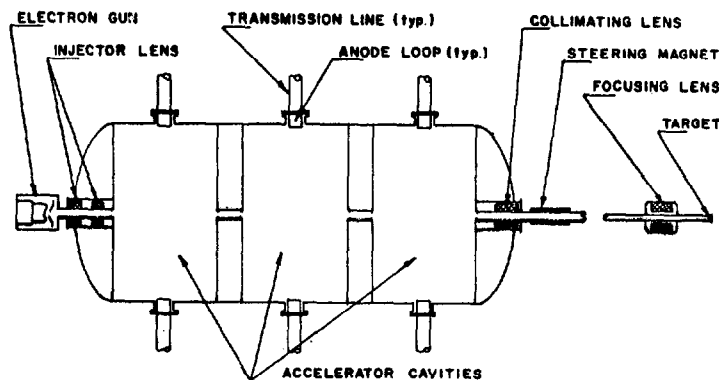

Fig 33 Schematic diagram of PHERMEX

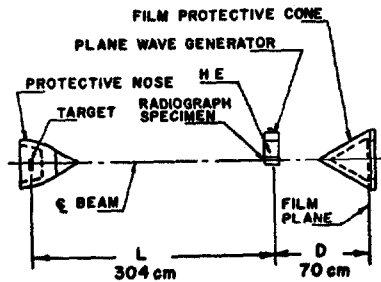

Fig 34 Experimental geometry

protects from blast damage the photographic film for recording the data

Among the experiments which were reported, there were several pertaining to measurements of the C-J (Chapman-Jouguet) particle velocity and sound speed; and one experiment concerned with an examination of the polytropic equation of state for reaction products of condensed explosives

79) A.J. Clear, "Standard Laboratory Procedures for Determining Sensitivity, Brisance and Stability of Explosives", **PATR 3278** (Dec 1965) [Superseding PATR FRL-TR-25 (1961): Impact Test with Picatinny Arsenal Apparatus (pp 2-4 and Figs 1, 2, 3 & 4, pp 32-35); Impact Test with US Bureau of Mines Apparatus (pp 4-7 and Figs 5, 6 & 7, pp 36-38); Modified Impact Tests for Liquid Explosives (7); Explosion Temperature Test (pp 7-8 and Fig 8, p 39); Decomposition Temperature Test (8); Sensitivity to Initiation by Sand Test (pp 9-11 and Figs 9, 10, 11 & 12, pp 40-43); Sensitivity to Initiation by the Modified Sand Test for Liquid Explosives (12-14); Electrostatic Sensitivity Test (pp 14-15 and Figs 13, 14, pp 44-45); Brisance by Sand Test (16); Modified Sand Test to Determine Brisance of Liquid Explosives (16); Determination of Initiating Efficiency by Sand Test (17); Stability by 75°C International Test (18); Stability by 82.2°C KI Test (19); 100°C Heat Test (19); Vacuum Stability Tests at 90, 190 & 120°C (pp 19-22 and Figs 15, 16 & 17, pp 46-48); Surveillance Tests at 65.5, 80, 120 & 134.5°C (pp 22-25 and Fig 18, p 49); Taliani Test (pp 25-27

and Fig 19, p 50); 65.5° KI Test (pp 27-29 and Fig 20, p 51); Reactivity Tests (29-31)

79a) W.M. Sigmon, Jr, "Shock Testing with High-Explosive-Initiated Gas Detonations", AEC Accession No **1566**, Rept No **SC-DC-65-1545** (1965); NuclSciAbstr **20**(1), 207-08 (1966) & CA **65**, 8654 (1966) [A simple, convenient method was developed for controlling pulse rise times in explosive gas tests. The method devised for control of rise times, or sweep velocities, consists of using small strands of solid high explosives to propagate the gas detonation. By properly positioning, the explosive strands relative to the test item surface, a wide range of shock pulse sweep velocities is possible. This method lends itself well to large or complex shapes. Strands of explosive are arrayed in a frame at the proper orientation with the test item. The assembly is then placed in a detonation chamber filled with an explosive gas mixt. The HE initiation provides the proper sweep velocity or rise time while the pulse amplitude and duration are controlled by the setup parameters. Tests to investigate the performance of this method were conducted in four types of setups: 1) frangible wooden chambers; 2) a rectangular steel chamber; 3) a 16-in diam, 14-ft long detonation tube; and 4) a 26-in diam, 130-ft long tube. The gas mixt ordinarily used was H and O with Primacord as the solid explosive. Exptl results were quite encouraging and generally confirmed predictions. Shock front sweep velocities of as high as 30000 ft/sec were obtained. The results indicate that high-explosive-initiated gas detonations will provide pressure pulses controllable in amplitude, duration, and rise time for blast load simulation and other shock tests requiring similar pulses]

80) Donna Price & T.P. Liddiard, Jr, "The Small Scale Gap Test; Calibration and Comparison with the Large Scale Gap Test", NOLTR **66-87** (1966), White Oak, Maryland [The SSGT, first described in 1952 by Dimmock, Jr (Ref 26), has been used in its modified form, described in 1961 by Ayres (Ref

47), as a conventional gap or shock sensitivity test carried out under small dimensions and under heavy confinement. It has been extensively used for testing small samples of expls and also to determine reliability of various fuze trains. Although it has been a useful tool, interpretation of its results has been restricted to lack of calibration and by unexplained reversals of explosive ratings when the testing was carried out on a large scale

The purpose of this investigation was to calibrate the apparatus shown in Fig 35, in order to permit direct interpretation of the 50% gap (attenuator thickness) in terms of the shock strength or amplitude. As result of this, the critical initiating stimulus could be given as shock stress at the end of the gap instead of in the completely arbitrary units previously employed. The SSGT has been calibrated over the range of 5 to 90 kbar

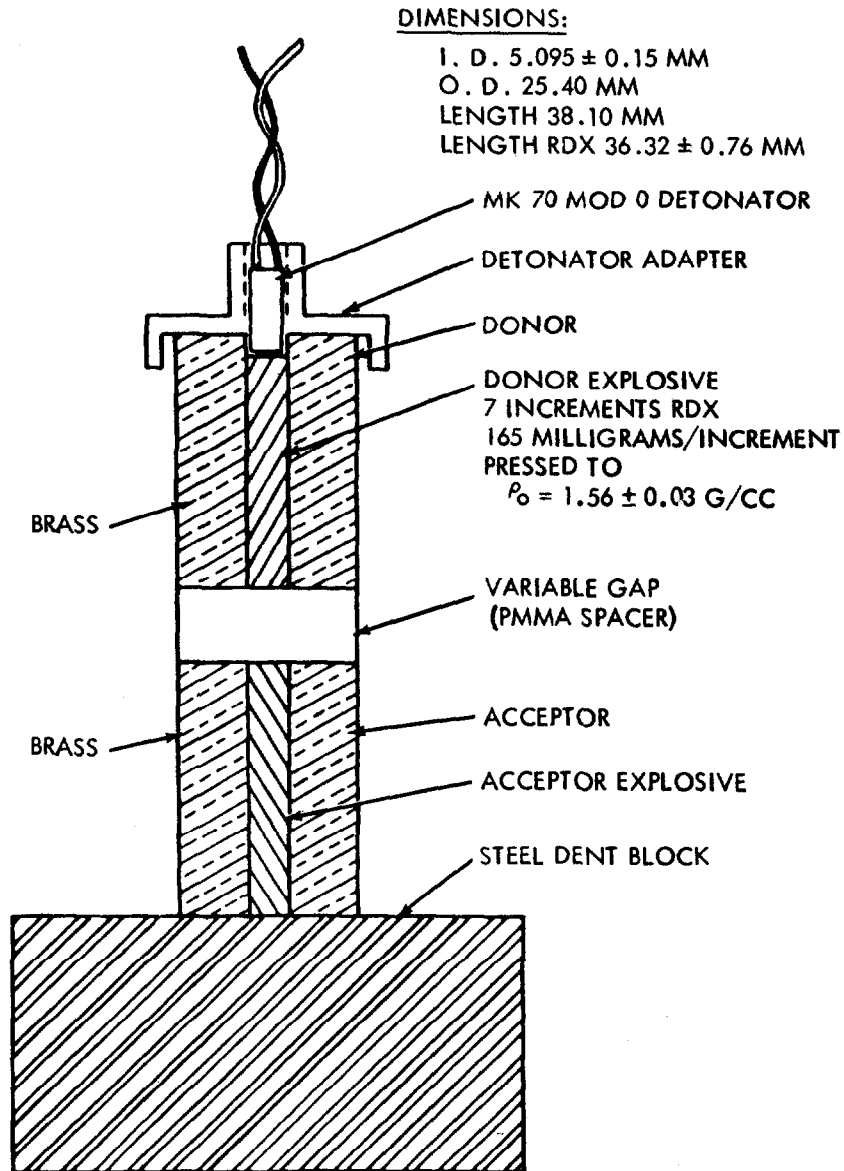

FIG 35 THE COMPLETE SSGT SETUP

The report also gives comparison of SSGT results with those from the standardized LSGT (large scale gap test). Such comparisons outline the conditions under which good correlation exists between the two sets of results. In addition, the study revealed other conditions under which rating reversals can be expected

Detailed description of calibration procedure is given on pp 1-16 of the paper

Comparison of test values of SSGT with those of LSGT is given on pp 16-32, the summary on p 32 and the Refs on pp 33-4

Supplementary data are given in Appendix A, pp 35-44. These include Tables A1, A2, A3 and A4 and "Charge Assembly for NOL Standardized Card Gap Test"

In Appendix B is described on p 45, the "Measurement of Shock Velocity"; on p 46 is given "Shock Velocity as a Function of Distance", when the shock has travelled in PMMA for SSGT (Table B1); on p 47, Fig B, a curve representing "Shock Velocity vs Distance in PMMA for the SSGT"; and on p 48 is a curve showing "PMMA Hugoniot Data Obtained in Calibration of SSGT"

81) Anon, "Military Explosives", Dept of the Army Technical Manual and Dept of the Air Force Technical Order **TM 9-1300-214/TO-11A-1-34** (1967) [Superseding TM 9-1910 (1955), listed here as Ref 29]. The following tests are described: Sensitivity to Impact by Picatinny Arsenal Apparatus and by Bureau of Mines Apparatus (pp 5-1 to 5-4); Sensitivity to Frictional Impact by Rifle Bullet Test (5-5 to 5-6); Sensitivity to Heat and Spark (5-6 to 5-9); Sensitivity to Initiation (5-9); Stability by Vacuum Stability Test and KI Test (5-9 to 5-15); Brisance by Sand Test and Fragmentation Test (5-15 to 5-18); Initiating Value Test for explosives used as booster charges is determined by means of the **Explosive Train Test**. In this test, an expl to be boosted (Tetryl, Tetrytol, Picric Acid, waxed PETN or RDX) is loaded into one end of a steel tube. One or more half-hard brass disks, 0.017-inch thick and of diameter slightly smaller than ID of the tube, are placed in the tube and pressed firmly against the end of the expl chge. On top of

the disks is placed a booster casing having a cavity with an ellipsoidal cross section and loaded with a weighed quantity of the booster explosive connected to a detonator. After exploding the booster, the chge beyond the disks was examined to see whether or not it underwent high-order detonation. Repeated tests were made until there was found the maximum number of disks that could be used without preventing detonation of charge beyond the disks. Then five tests were made with this number of disks and five tests with one more disk. The greater the initiating action of the booster explosive, the greater is the number of disks thru which the detonation can be transmitted. The tests indicated that Tetryl and RDX are equally effective and more so than PA in initiating other HE's. The test can be used also to determine the effectiveness of detonators in initiating HE's (pp 5-18 to 5-20). This test is similar to *barrier or gap tests* described here under Ref 80; Sympathetic Detonation or Detonation by Influence determined by Gap Test (5-20 to 5-21); Power by Ballistic Pendulum and Trauzl Test (5-21 to 5-24); Blast Effect Pressure by Piezoelectric Gage (5-24 to 5-27); Cratering Effect by explosion of charge buried deeply in the earth (5-28 to 5-29); Munroe-Neumann or Shaped Charge Effect by firing charges against targets (5-29 to 5-35)

82a) Anon, "Engineering Desing Handbook. Explosives Series. Properties of Explosives of Military Interest", AMCP **706-177** (1967), Headquarters US Army Materiel Command, Washington, DC, 20315 [This pamphlet supercedes PATR 1740, Rev 1 (1958), listed here as Ref 37]: Impact Sensitivity Test for Solids (pp 1-2); Impact Sensitivity Test for Liquids (2); Friction Pendulum Test (2); Rifle Bullet Test (2); Explosion Temperature (3); 75°C International Heat Test (3); 100°C Heat Test (3); Flammability Index (3); Hygroscopicity (3); Volatility (3); Vacuum Stability Test (4); Sand Test for Solids (4-5); Sand Test for Liquids (5); Sensitivity to Initiation (5); Trauzl Test (5-6); Plate Dent Test (6); Detonation Rate (6); Booster Sensitivity Test (6); Calorimetric Tests (6-7); 60-mm

Mortar Projectile Test (7); Bomb Drop Test (7); Fragmentation Test (7-8); Fragment Velocity Test (8); Blast Effect (8); Shaped Charge Effectiveness (8); Hydrolysis by 240 Hour Test (9); Sensitivity to Initiation by Electrostatic Discharge (9-10)

Armor Plate Impact Test and Bulk Compressibility Tests are described in PATR 1740, listed here as Ref 37

82b) Anon, "Materiel Test Procedure" MTP 4-2-814 (1967) (Fragment Velocity Measurement) (Superseding Ref 55e) (See also Vol 1, pp XII & XIII of Encycl)

83) Ellern, Pyrotechnics (1968): Particle Size Determination of Pyrotechnic Compositions (pp 259-61); Heats of Combustion of Elements and Compounds Used in Pyrotechnics (pp 276-80); Measurement of Stability and Reactivity of Pyrotechnic Compositions (pp 291-94); Ignition, Initiation and Decomposition of Pyrotechnic Compositions (pp 294-300); Hygroscopicity and Self-Destructive Interaction (pp 300-304); Survival and Surveillance of Finished Pyrotechnic Items (pp 304-307)

Detonation by Exploding Bridge-Wires. See under DETONATORS, PRIMERS, etc in Section 3, Part C of this Volume

Detonation of Explosive Mixtures is discussed by I.M. Voskoboinikoff & G.S. Sosnova in *ZhurPrikladMekhan i TekhnFiz* **1961** (4), 133-35 & *CA* **56**, 3712 (1962). Calcd deton velocities & temps were compared with exptl values for mixts of Tetranitromethane (TeNM) with C_6H_{14} , CH_3NO_2 , $PhNO_2$ & DNT; NG with MeOH & CH_3NO_2 ; suspensions of C & TNT in TeNM; and solid expls such as Ammonal & Pentolite. Velocities were detd by the ionization method to within 50 m/sec. Temps were detd optically to within $150^\circ K$. The calcd velocities were made assuming that each compd would give the same decompn products that would be obtd had it been exploded separately. Calcns were also made assuming these products would or would not react with each other. The decompn products

from the individual compds in a homogeneous soln reacted with each other, while there was little or no reaction with solid mixts or suspensions

"Detonation and Explosives Phenomena".

Title of a series of USBurMinesProgress Reports by C.M. Mason & F.C. Gibson, Nos 1 to 8, beginning July 1, 1953 and ending June 30, 1955, OrdnProject TB2-0001, Army Project 599-01-004. This project was not really new but resulted from consolidation of two projects previously conducted separately as "Fundamental Research on Explosives Phenomena" and "Detonation Involving Novel Photographic Methods", carried on respectively as Ordnance Projects TA3-5001 and TB2-0001

The reports cover the following subjects:

- 1) "Physics and Chemistry of Explosives Phenomena", which includes, among other items, determinations of: initiation of detonation, electrical effects and luminosity accompanying detonation, detonation velocity and temperature of detonation
- 2) "Studies of Gaseous Detonation"

The title of these reports beginning with No 9 and ending with No 12, covering the period July 1, 1955 to June 30, 1956 was changed to the *Research Program on Detonation and Explosives Phenomena*, OrdnCorps-Project TA3-5101, ArmyProj 504-01-015

No Final Report covering these progress reports was issued

Detonation, Explosive Wave Shaping by Delayed. M.M. Sultanoff discussed this subject at the Proceedings of the First Symposium on Detonation Wave Shaping (sponsored by Picatinny Arsenal) at the Jet Propulsion Laboratory, Pasadena, California, June 5-7, 1956

Detonation, Extinction of. See under Detonation; Attenuation, Break, etc

Detonation, Eyring Absolute Reaction Rate Theory. See "Absolute Rate Theory" in Vol 1 of Encycl, p A4-R and in Cook (1958), p 134, Detonation, Eyring et al

Detonation, Eyring et al Curved Front Theory.
See Detonation (and Explosion), Curved Front
Theory of Eyring et al

**Detonation, Factors Influencing Velocity
and Other Properties of Explosives in.**

Dunkle (Ref 7, p 205) listed the following
factors:

- a) Chemical nature of the explosive
- b) Degree of confinement and charge diameter
- c) Charge density
- d) Particle size distribution of the explosive
- e) Homogeneity of explosive, especially important for mixed explosives
- f) Nature of the initiation
- g) Initial temperature of the explosive charge
- h) External pressure
- i) External temperature (added by us)
- j) Presence of inert components

The strong influence exerted by many of these factors, particularly degree of confinement and charge diameter, shows that the energy release which is initiated in the detonation front does not occur instantaneously. Hence, any theory must take account of the *lateral expansion* [See Detonation (and Explosion), Lateral Expansion in, etc]

Refs: 1) J.L. Copp & A.R. Ubbelohde, "The Effects of Inert Components on Detonation", *TrFaradSoc* **44**, 658-69(1948) 2) R.B. Parlin & D.W. Robinson, "Effect of Charge Radius on Detonation Velocity", UnivUtah-Inst for Study of Rate Processes, Contract N7-onr-45107, **TR VII**, Oct 1952 3) M.E. Malin et al, "Particle Size Effects in Explosives at Finite and Infinite Diameters", *JApplPhys* **28**, 63-69(Jan 1957) 4) G.J. Horvat & E.J. Murray, "Propagation of Detonation in Long Narrow Cylinders of Explosives at Ambient Temperature and at -65° F", *PicArns SFAL TechRept* **2389** (Jan 1957) 5) J.E. Bubser, "Investigation of the Effects of Confinement on Stable Type Detonators", Atlas Powder Co, Contract DAI-28-017-ORD-(P)-1207, Final Rept, April 1957 (Conf) (Not used as a source of info) 6) D.H. Edwards & G.T. Williams, "Effect of Tube Diameter on the Pressure in Gaseous Detonation Waves", *Nature* **180**,

1117 (Nov 1957) 7) Dunkle's Syllabus (1957-1958), pp 203 & 205 8) Cook (1958), 143 (Influence of electrical and magnetic fields on detonation velocity)

Detonation, Fadeout or Fading of. See under Detonation, Attenuation, Break, Cutoff, etc

Detonation, Fading of in Solid Explosives is discussed by O.A. Gurton in *ProcRoySoc* **204A**, 31-2(1950); *CA* **45**, 10585 (1951)

Detonation, Failure of. See under Detonation, Attenuation, Break, Cutoff, etc

Detonation, Failure of Coal-Mining Explosives in a Bore Hole. Accdg to H. Fukuda (Ref), the interruption of detonation of small diam cartridges of coal-mining explosives in a bore-hole was studied. Cartridges were loaded in pipes made of steel, lead, glass, or cardboard paper. They were primed with a No 6 elec blasting cap, and the detonated lengths of cartridges were measured. The results obtained are: 1) Interruption of detonation occurs irrespective of the pipe material. 2) When the ratio A_c/A_e of the sectional area of the clearance to that of the cartridge is in a certain range, interruption is not observed. 3) When perforated steel pipes are used, no interruption is observed. In this case, part of the shock pressure dissipates thru the holes, consequently the effect of disturbance on further propagation of detonation is reduced. 4) When the inside of the steel pipe is covered with a fibrous material like absorbent cotton, the reflected shock wave is probably absorbed and detonation is not interrupted. 5) When the explosives are wrapped with thin metallic cartridges instead of paper, detonation is not interrupted, because it is strong enough to resist the reflecting detonation wave. 6) Existence of a thin layer of water around the cartridges can also prevent the interruption of detonation. The water layer perhaps acts as a hard wrapper material
Ref: H. Fukuda, *KôgyôKayakuKyôkaishi* **22**, 71-82(1961) & *CA* **59**, 6189(1963)

Detonation, Failure Diameter in. Same as Critical Diameter in Detonation

Detonation, Fanno Line. The Fanno "cure" is used to represent the Rankine-Hugoniot mass & energy equations (together with the medium equation of state) in an enthalpy-entropy plot (See Fig from Ref 1). In this

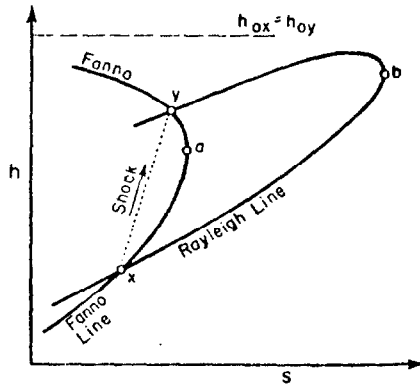

Fig Fanno line and Rayleigh line

plot the Rayleigh-Mikhel'son line will appear as a second curve. The two intersections of these curves provide the initial & final states across the shock. Each curve may be interpreted in terms of changes in entropy, enthalpy and Mach numbers and may be related to either stagnation enthalpy or impulse
Refs: 1) A.H. Shapiro, "The Dynamics of Thermodynamics of Compressible Fluid Flow", Ronald Press, NY (1953), pp 114 & 192
 2) Dunkle's Syllabus (1957-58), pp 99 & 101

Detonation (and Explosion), Flame (or Light) in. See Detonation (and Explosion), Luminescence (or Luminescence) Produced on

Detonation, Flame Reactions and. See W. Döring, p 630 of Report of German Bunsen Gesellschaft für physikalische Chemie on *Flame Reactions and Detonations* at Troisdorf, Oct 1956 and in *Z Elektrochem* **61**, 5, pp 559-692 (1957)

Detonation (and Explosion), Flammability Characteristics of Combustible Gases and

Vapors is discussed by M.G. Zabetakis in *USBurMinesBulletin* **627** (1965)

Detonation (Explosion, Flammability and Ignition). These subjects are discussed in the book of S.S. Penner & B.P. Mullins, "Explosions, Detonations, Flammability and Ignition", Pergamon Press, NY (1959)

Detonation, Flash-Across, Heat Pulse and Hypervelocity Phenomena. According to Cook (Ref 3), the phenomenon of *heat pulse* was first recognized by Dr W.S. McKewan of NOTS, China Lake, Calif while viewing microsecond, color, framing photographs of Nitromethane (NM) detonated thru SPHF (shock-pass-heat-filter) glass plates in experiments conducted by D.H. Pack, W.A. Gey & M.A. Cook (Ref 4). Their experiments in propagation of deton thru steel & glass plates showed that thin plates of inert material invariably interrupt the deton wave completely, requiring the deton to re-form if it continues to propagate beyond the interrupter. A remarkable "new" phenomenon, called *flash-across*, was observed when a bluish-white hot spot on one frame and another hot spot that developed between adjacent frames on the opposite SPHF plate had both flashed across the chge and met at the collision interface

In order to accurately determine the speed of the flash-across phenomenon, the experiment was repeated and recorded by streak camera with color film. Also thinner SPHF plates were used. In the streak camera trace, 8.5 μsec after each initial wave entered the NM, a hot spot appeared at the surface of each plate and flashed to the center of the chge each at the phenomenal speed of 35 mm/ μsec . Cook (Ref 3) considers the flash-across phenomenon to be the heat pulse predicted by M.A. Cook, R. Keyes & A.S. Filler (Ref 1)

Chaiken (Ref 5) reported that his prior streak camera studies of the shock initiation to deton of NM indicated the existence of a "hypervelocity" wave moving behind the initiating shock front. It was suggested that the deton reaction wave originated be-

hind the initial compression front, and traveled at a "super-velocity" in the compressed expl to overtake the initiating shock front. Chaiken believes that this deton initiation process could be an alternate explanation for the "flash across" phenomenon observed by Cook et al, and also offers an explanation for the hypervelocity wave in large crystals of PETN noted by Holland et al (Ref 2)
Refs: 1) M.A. Cook et al, *TrFaradSoc* **52**, 363 (1955) 2) T.E. Holland et al, *JAppl-Phys* **28**, 1212 (1957) 3) Cook (1958), 87-89 4) M.A. Cook et al, 7thSympCombstn (1959), 820 5) R.F. Chaiken, 3rdONRSymp-Deton (1960), 304-08

Detonation (and Explosion) Force or Impetus. See under Detonation (and Explosion); Power, Strength, Impetus or Force

Detonation (and Explosion), Fragmentation Tests. See under DETONATION (AND EXPLOSION), EXPERIMENTAL PROCEDURES

Detonation, Frank-Kamenetskii Equation. See at the end of description of "Detonation (and Explosion), Initiation (Birth) and Propagation (Growth or Spread) in Explosive Substances

Detonation, Free Surface Velocity Method for Determination of Detonation Pressure is briefly discussed under Detonation (and Explosion), Pressures of and Their Measurements

Detonation, Free Volume Theory of the Liquid State Developed by Eyring et al and by Lennard-Jones-Devonshire. The free volume theory of the liquid state developed by Eyring & Hirschfelder (Ref 1) and by Lennard-Jones & Devonshire (Ref 2) has provided a useful approximate description of the thermodynamic props of liquids in terms of intermolecular forces

In its simplest form, this theory imagines the available space to be divided into cells whose centers form a regular lattice spanning the available vol. Each cell contains a single molecule; all but one are assumed

fixed at their cell centers and this one is allowed to move in the force field of its neighbors which are "smeared out" onto a sphere of radius equal to the nearest neighbor-distance

A number of improvements & modifications of this theory have been made, such as by Kirkwood (Ref 3), Buehler et al (Ref 4), Wood (Ref 5), and Dahler & Hirschfelder (Ref 6)

Fickett (Ref 7) used the original LJD theory in computer calculations of the deton products of condensed expls. This was done partly on the grounds of vested interest in machine codes already prepd and partly because it gave reasonably good agreement with the "Monte Carlo calculations" at high densities, and in the calcn of Hugoniot curves the errors in E & H appeared to cancel each other to some extent

Refs: 1) H.J. Eyring & J.O. Hirschfelder, *JPhysChem* **41**, 249-57 (1937) 2) J.E. Lennard-Jones & A.F. Devonshire, *PrRoySoc* **163A**, 53 (1937); **165**, 1 (1938) 3) J.G. Kirkwood, *JChemPhys* **18**, 380-82 (1950) 4) R.J. Buehler et al, *JChemPhys* **19**, 61 (1951) 5) W.W. Wood, *JChemPhys* **20**, 1334 (1952) 6) J.C. Dahler & J.O. Hirschfelder, *JChemPhys* **32**, 330 (1960) 7) W. Fickett, "Detonation Properties of Condensed Explosives Calculated with an Equation of State Based on Intermolecular Potentials", Los Alamos Scientific Laboratory Rept **LA-2712** (1962), 31-33 (Contract W-7405-ENG 36 with US AEC)

Detonation, Free Volume Theory of Multi-component Fluid Mixtures. The free volume theory of the liq state is extended to multi-component fluid mixts by using the method of moments in the treatment of the order-disorder problem. The results of this extension are given in the article by Z.W. Salsburg & J.G. Kirkwood, *JChemPhys* **20**, 1538-43 (1952)

Detonation Front, Non-Planar. Most real detonation fronts are not plane but curved. Curved detonation fronts may either be steady or non-steady. For example, the

detonation wave passing thru a long cylindrical stick of explosive, either cased or bare, presumably ultimately settles down to a steady state, although the front is not quite plane, but bends back a little at the edges because of the "sideways expansion", (also known as "lateral expansion"). The spherical detonation wave in an infinite explosive, originating from a small region at the center, strictly speaking, reaches a steady state only asymptotically. There are some expls which, when formed into thin sticks often fail to propagate at steady state even if they are initiated by a strong booster. As an example of such an expl is TNT in sticks of 1 inch diameter or less Ref: W.G. Penney, "Introduction to the Discussion on Detonation", PrRoySoc **204A**, pp 7-8 (1950) (Non-planar detonation fronts)

Detonation Front and Shock Front. Detonation Zone and Shock Zone. The shape of the detonation wave and density-distance & particle velocity-distance relations behind the wave front are of considerable practical & theoretical importance. The deton wave emerging from the end of an unconfined cylindrical chge of a condensed expl is in general spherical in shape. The curvature of this front has a marked effect on both rate & pressure of deton. It has been found that there is a minimum radius of convex curvature for each expl, below which deton will not propagate. The min radius of curvature is primarily that at which the divergence is so great that the energy released from the chem reaction of the very small vol of expl involved is insufficient to compensate for the rapid increase in area in the deton front. In other words, all expls detonated from a point will quench unless the booster develops a deton front having a radius of curvature greater than the min for the expl being boosted. The thickness of the deton front is taken as that of a typical shock front, ca 10^{-5} cm

Cook (Ref 7) has illustrated the cross-sectional view of the concept of the deton front & shock front as shown in the Fig

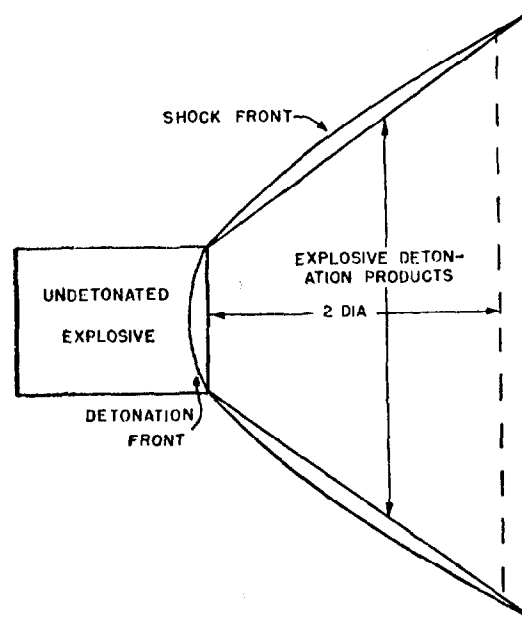

Fig Cross-sectional diagram of a blast contour in air

In contrast to the shock zone, the detonation zone includes the shock zone (10^{-5} cm) & the chem reaction zone (0.1 to 1.0 cm). These two zones together make up the deton zone. In the shock zone little or no chem reaction occurs, but the pressure reaches its peak due to the shock. At or near the forward boundary of the second zone, the high temp to which the expl has been raised by compression in the shock zone initiates chem reaction. As the material moves toward the rear boundary of the chem reaction zone, the resulting expansion lowers the pressure so that this falls thruout the zone. See also Detonation Head and Its Development

Addnl info on these subjects may be found in the following Refs
 Refs: 1) G.I. Taylor, "The Dynamics of the Combustion Products Behind Plane and Spherical Detonation Fronts in Explosives", PrRoySoc **200A**, 235-47 (1950) 2) C.G. Dunkle, "Detonation Zone", Informal Report, PicArnsn, Dover, NJ (1952) 3) W.R. Gilkerson & N. Davidson, "On the Structure of a Detonation Front", 2ndONRSympDeton, Vol 2 (1955), 98-112 4) H.D. Mallory & S.J. Jacobs, "The Detonation Zone in Con-

densed Explosives", Ibid, pp 240-64 5) M.A. Cook, "Detonation Wave Fronts in Ideal and Non-Ideal Detonation", Ibid, pp 382-400 6) Dunkle's Syllabus (1957-58), pp 163-68 7) Cook (1958), Chapter 5 8) H.H. Calvit, "Motion of the Detonation Products Behind Plane and Spherical Detonation Waves in Solid Explosives", Penn State Univ, Dept of Engrg Mechanics Tech Rept 3 (30 Nov 1964) (Dept of Army Contract DA-36-034-ORD-3576RD) 9) M. Lutzky, "The Flow Field Behind a Spherical Detonation in TNT Using the Landau-Stanyukovich Equation of State for Detonating Products", **NOLTR 64-40** (Dec 1964) 10) N. Lundborg, "Front and Mass Velocity at Detonation in Evacuated Chambers", 4th ONRSympDeton (1965), pp 176-78

Detonation (and Explosion), Fugacity of Products of. Cook (1958), p 381 describes a method of calculating fugacities and the calcn of equilibrium concentrations using ratios of fugacities

Detonation (and Explosion), Gap Tests.
See under Detonation (and Explosion), Experimental Procedures

Detonation (and Explosion) in Gases.

Prior to reading this subject, it is advisable to see "Burning (Combustion) and Deflagration of Gases, Vapors and Dusts; Detonation and Explosion of Dusts and Mists (Vapors); and Detonation (or Explosion), Development (Transition) from Burning (Combustion) or Deflagration" described in this Volume

All known gases, called *real gases*, are *nonideal*, which means that they do not obey the fundamental gas laws and the equation $pV = RT$ [See under "Detonation (and Explosion), Equations of State", in this Volume]. Specific heats of "real gases" vary with temperature and the product composition depends upon both temperature and pressure. If the gas were *ideal* or *perfect* it would obey the above gas law. In this case, it could be assumed that as the pressure on the gas be-

comes infinitely small, the gas approaches nearer and nearer to the state where there is no viscosity or internal resistance to molecular motion. It is also assumed: 1) that in mixtures of ideal gases, the nature and extent of the chemical reaction is independent of the pressure and temperature in the detonation wave; 2) that the entire energy released by this reaction is available for the propagation of the wave; and 3) that the products of reaction are also ideal gases whose energy is independent of pressure (Refs 11, 24 & 32)

Accd to Coward (Ref 23, pp 961 ff), who discussed deflagrations and explosions in gaseous mixtures from the point of view of safety in industrial operations, it is hardly possible to differentiate between "flammable" and "explosive" mixtures as these terms are generally regarded as synonymous. He also stated that the speed of propagation of flame by a flammable mixt of gases may be as low as a few cm/sec, or as high as several hundred meters/sec. The speed is affected primarily by the compn of the mixt, but it may be so much influenced by other factors that some mixts which transmit flame quietly and slowly in some circumstances become strongly explosive in others

Accd to Lewis & von Elbe (Ref 59, p 200), a *deflagration wave* propagates by the processes of heat transfer and diffusion, whereas a *detonation wave* is a shock wave maintained by the energy of the chemical reaction initiated by the compression in the wave. Deflagration waves are slow compared to the velocity of sound, and their speed may be only a few cm/sec, whereas detonation waves travel faster than sound, in some cases several times as fast. The speed is determined primarily by the composition of the mixture, but it is so much affected by other factors that some explosive mixtures can support either type of wave, depending on circumstances (See also Ref 23, p 983)

Kistiakowsky (Ref 24, pp 955-56), in discussing calculation of detonation parameters for hydrogen-oxygen mixts, stated that although they can be carried out as for

ideal gases, the assumption of complete reaction is untenable. The introduction of mobile equilibria betw O_2 , H_2 , HO & H_2O leads, however, to laborious calcns by successive approximations, but this was done by Lewis & Friauf (Ref 3), whose results are given in Table II of Ref 24, p 955 for the following parameters: final pressure, p in kg/cm^2 ; final temp, T in $^\circ K$; and deton velocity, m/sec . The calcd values agree fairly well with experimental data and with calcns by Berets et al (Ref 22, pp 1086-91) who utilized more accurate data on heat capacities at high temps (Ref 24, p 955)

Taylor (Ref 33, p 80) discussed calcns for stable deton of expls giving the products which are ideal gases and on p 83 he discussed deton in real gases and dusts

Accdg to Cook (Ref 48, p 45), studies of deton of expl mixts: oxygen, hydrogen, nitrogen, acetylene, argon and others covering the range of initial pressures p_1 from below atmospheric to 50-100 atm, showed that $D^*(\rho_1)$ frequently followed closely the (constant temperature) relation:

$$D^* = D^* \rho_1^{\beta^*} + \beta^* \log \rho_1 / \rho_1^0 = D^* p_1^{\beta^*} + \beta^* \log p_1 / p_1^0 \quad (\text{Eq 1})$$

where * (asterisk) denotes ideal detonation. Thus $D^* \rho_1^0$ is the theoretical maximum or hydrodynamic value of the detonation velocity when the initial density and pressure are respectively ρ_1^0 and p_1^0 , and D^* is the theoretical maximum or hydrodynamic value of the detonation velocity for any other initial density and pressure ρ_1 and p_1 respectively; β^* is the increase in the hydrodynamic detonation velocity for a tenfold increase in density or pressure

For an ideal gas, the density ratio equals the pressure ratio

Cook (Ref 48, p 46) also gives in Fig 3.1 curves of velocity D versus $\log p_1$ for gaseous explosives and in Table 3.2, p 46 he gives constants of the above equation for 15 explosive gaseous mixtures. Fig 3.1 is not reproduced here

Taylor (Ref 33, pp 84 & 85) gives two tables for detonations in gaseous explosives, Table 19 lists 18 mixtures and Table

20 gives 17 mixtures

Table 1 gives selected values for ρ_1^0 , $D^* p_1^0$ and β^* as taken from Cook (Ref 48, p 46):

Table 1

| Mixture (Mole ratios) | ρ_1 (psia) | $D^* p_1^0$ (m/sec) | β^* (m/sec) |
|--------------------------|--------------------|------------------------|----------------------|
| $6H_2-O_2$ | 100 | 3800 | - |
| $4H_2-O_2$ | 10 | 3220 | 325 |
| $2H_2-O_2$ | 10 | 2810 | 160 |
| H_2-O_2 | 10 | 2300 | 100 |
| H_2-2O_2 | 10 | 1920 | 10 |
| $2H_2-O_2-N_2$ | 10 | 2420 | 60 |
| $3C_2H_2-O_2$ | 15 | 2520 | 0 |
| $2C_2H_2-O_2$ | 15 | 2660 | 45 |
| $C_2H_2-O_2$ | 15 | 2920 | 160 |

Meanings of ρ_1^0 , $D^* p_1^0$ and β^* are given after Eq 1

It is mentioned under "Burning (or Combustion) and Burning Characteristics of Gases, Vapors and Dusts", described in this Vol, that while burning rate depends to a certain extent on the diameter of pipe in which the gas burns, the detonation rate does not depend on diameter, provided it is sufficiently large

It was also remarked that detonation velocity of gases depends on composition of mixture and its heat of reaction, while initial pressure and temperature have practically no effect on velocity, provided the initial velocity is not too small

Zel'dovich & Kompaneets (Refs 42a & 55) give the following discussion on detonation in gases:

"A detonation wave front represents a strong shock wave which heats the gas to an extremely high temperature. At such a temperature a chemical reaction proceeds violently, giving off heat at an *explosive rate* in some zone behind the front. Behind this zone the products are greatly expanding. The energy of the chemical reaction supports the travelling shock wave"

It was further stated that the energy of the shock wave is continuously expended in the irreversible heating of a compressible substance and, therefore, a stationary shock

wave cannot exist without an external source of energy. In a detonation wave this energy is given off by a chemical transformation. In addn to supporting the wave, this energy also contributes to the heating of the reaction products. The detonation can be propagated over as long a path as desired with constant velocity and pressure in the wave, since the energy of the chemical reaction is confined to the medium and can be liberated only by detonation. It has been shown that with a deton wave velocity of 2-3 thousand m/sec the temperature at the front of the shock wave is high enough to give rise to a reaction which progresses explosively. The thickness of a strong shock wave front is not greater than the length of the mean "free path", which is an average distance traveled by an atom, molecule or electron before colliding with another atom, molecule or electron. As it has been previously proven, only a very small fraction of collisions have any chemical effect, many collisions are required in order to produce a strong reaction. This means that the reaction zone in the detonation of gases must be much thicker than the shock wave front which ignites the gas. The region where the gas has already been compressed but has not yet begun to react can be sharply delineated from the region where the reaction has for the most part taken place (Refs 42a & 55)

In this connection Zel'dovich & Kompaneets constructed three reference surfaces: one, designated as 0, ahead of the front (where the undisturbed medium is found); another, designated as 1, immediately behind the front (where the substance has already been compressed but the reaction has not yet begun); and a third, designated as 2, in the region where the reaction has been completed

Assuming that deton velocity, D , is known and that the sp heat c_p , of a mixture at const pressure is constant and does not depend on the temperature, the enthalpy of initial stage can be expressed as:

$$H_0 = \frac{k}{k-1} P_0 v_0 + Q = c_p T_0 + Q \quad (\text{Eq 2})$$

where Q =chemical energy; k =sp heat con-

stant, c_p/c_v ; P_0 =pressure uncompressed gas; v_0 =specific volume of uncompressed gas; c_p =sp heat at const pressure; c_v =sp heat at constant volume; and T_0 =absolute temperature in °K. Enthalpy (or "heat function") is connected with the energy by the relation: $H = \dot{E} + pv$

The enthalpy in the region directly behind the front is:

$$H_1 = \frac{k}{k-1} P_1 v_1 + Q = c_p T_1 + Q \quad (\text{Eq 3})$$

where P_1 & v_1 are pressure and specific volume at the state of compression

For the change of enthalpy, Z & K give on p 71 the expression:

$$H_1 - H_0 = \Delta H = c_p \Delta T = \frac{(v_1 + v_0)(P_1 - P_0)}{2} \quad (\text{Eq 4})$$

As the relation between compressed and uncompressed gas can be expressed as:

$$v_1/v_0 = (k-1)/(k+1) \quad (\text{Eq 5})$$

and as velocity of shock wave is expressed by the equation:

$$D^2 = v_0^2 \frac{P_1 - P_0}{v_0 - v_1} \quad (\text{Eq 6})$$

we can rewrite the equation for ΔH as follows:

$$\Delta H = c_p \Delta T = \frac{D^2}{2} \left[1 - \left(\frac{v_1}{v_0} \right)^2 \right] = \frac{D^2}{2} \left[1 - \left(\frac{k-1}{k+1} \right)^2 \right] \quad (\text{Eq 7})$$

As an example for application of above formulas, Z & K give detonation of $2H_2 + O_2$ mixture with velocity $D = 2800$ m/sec (Ref 55, pp 71-2)

Thermodynamic detonation velocity can be calcd from the equation:

$$D = \sqrt{2(k^2 - 1)Q} \quad (\text{Ref 55, p 83}) \quad (\text{Eq 8})$$

It was stated on p 73 of Ref 55 that for stationary motion of the gas Eq 6 for D^2 should be fulfilled for any reference surface which is constructed inside the reaction zone, since the process cannot be stationary if the propagation velocity, D , is different at different points. Therefore, D is identical for all reference surfaces. If we illustrate the processes which are taking place in the detonation wave, which has specified velocity D , in a p, v diagram, then they will

all correspond to the points of a straight line which is expressed by the equation:

$$p = p_0 + \frac{D^2}{2}(v_0 - v) \quad (\text{Eq 9})$$

The straight line expressed by this equation is called in Amer & European literature *Rayleigh Line* (Ref 48, pp 67 & 79) because it was proposed by Lord Rayleigh (1842-1919). In the Rus literature, the line is called *Priamaya Mikhel'sona* (Straight Line of Mikhel'son) because it was claimed that it was proposed independently from Lord Rayleigh by the Rus scientist Vladimir A. Mikhel'son (1860-1927) [Ref 55, p 74 & V.A. Mikhel'son, "Collective Works", IzdatNovy-AgronomMoscow, Vol 1(1930), p 114]. We think that it would be fair to call it the *Rayleigh-Mikhel'son Line*. The straight line

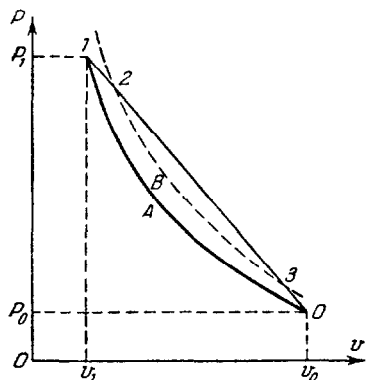

Fig A

01 shown in Fig A taken from Refs 42a & 55 is the R-M Line. The state 1 of Fig A, which is directly behind the shock wave front, is obtained from state 0 by a sudden change. As this transition takes place over the length of the mean free path, it should not be considered that the substance changes state along the straight line 01, but by the line 0A1, which is known as *Hugoniot adiabat*. As the chemical reaction begins and heat is given off behind the shock wave front (which is reference surface 1), another Hugoniot adiabat, which corresponds to intermediate state, can be constructed. This adiabat, shown by the dotted line 2B3 lies above 0A1, since in the *pv*-diagram it should correspond

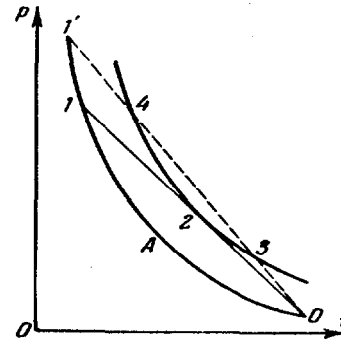

Fig B

to the points with higher values of the enthalpy. On the other hand, the state should change along the straight line 01 and in order to fall on the dotted adiabat it must be shifted from point 1 to the right. The chemical reaction and liberation of heat behind the shock wave front is accompanied by rarefaction, a diminution of density and pressure

Further in their investigation, Z & K have shown that, upon propagation of the detonation wave without additional compression from behind or induced ignition ahead of the front, the adiabat which corresponds to the total liberation of heat (Q) from the chemical reaction should be tangent to the line 01 of Fig A

In Fig B is shown, besides the adiabat 0A1, also adiabat 324 which corresponds to the total heat liberated. Equations for 324 and 0A1 are derived by Z & K and are given on pp 75 & 76 of Ref 55. The deton velocity corresponding to the straight line 01 is, in general, the smallest possible for a line which has a point in common with the adiabat 423. Any other straight line, 0341', which intersects both adiabats, and has a larger slope, has higher velocities. The stationary process which is associated with rarefaction along the straight line 10 reduces the substance to a state which corresponds to the total liberation of heat. The state of the reacting mixture varies continuously along the line 01 and the compn is detd from the equation of chemical kinetics. Since the reaction proceeds irreversibly, the entropy of the entire reacting mixt increases irreversibly and attains a maximum

on the line 01 at the point of tangency with 2, which corresponds to the total liberation of heat. Point 2 is known as Chapman-Jouguet point. On comparing the change in entropy along the straight line 1'4 and the change along line 12, it is easy to see that near point 4 the entropy has its largest value on the interval 1'4, but it does not reach a maximum. For a small shift along the straight line 021 the entropy does not change about the point of tangency and, therefore, does not vary near the same point on the adiabat 423. Consequently, (over a small interval near the point of tangency) the *Hugoniot adiabat* coincides with the *isentrope*. Since this adiabat corresponds to the total liberation of heat, it is possible to say that at point 2 the Hugoniot adiabat coincides with the isentrope for the reaction products. If the particle velocity of reaction products is ω at point 2, detonation velocity is D , then:

$$D - \omega = \sqrt{\left(\frac{\partial p}{\partial \rho}\right)_s} \quad (\text{Eq 10})$$

where the right hand side of this equation is the local velocity of sound

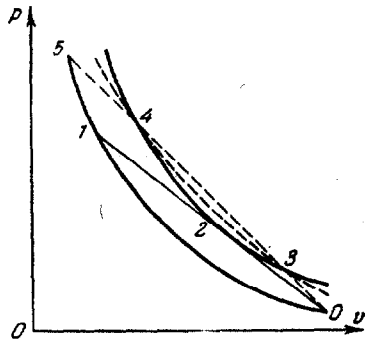

Fig C

In order to show that the stationary regime is associated with the straight line 01, which is tangent to the upper adiabat at point 2 (CJ point), Z & K considered the two proximate regimes 3 & 4 (Fig C), which correspond to one and the same deton velocity D' , since they lie on the same straight line 034. The regime 4 describes a somewhat *overcompressed* deton wave, since $p_4 > p_2$,

while regime 3 is an *undercompressed* wave ($p_3 < p_2$), where p_2 is pressure at point 2. The velocity D' for both these waves is greater than D . The condition for the conservation of mass for both regimes may be written as:

$$\frac{D' - \omega_3}{v_3} = \frac{D' - \omega_4}{v_4}$$

and it can be interpreted as the law of conservation of matter in the shock wave traversing the reaction products which are in state 3. This wave changes state 3, by a jump, into state 4

In further discussion, Z & K have shown (Ref 55, p 80) that velocity of the shock wave relative to 3 is equal to $D' - \omega_3$, while relative to the substance 3 it is equal to $D' - \omega_4$. Such a shock wave corresponds to a sudden change in a homogeneous substance, which refers to the upper adiabat (the solid curve of Fig C). But if one writes the equation of the conservation of energy for the shock wave 34, it will have its own adiabat, shown as dotted line between straight lines 3, 4 & 01. This adiabat has two points, 3 & 4, in common with the adiabat which refers to the original volume v_0 . As the dotted adiabat is concave downward, it becomes steeper above point 4, than the straight line 345, which means that its velocity above 4 will be greater than that for dotted straight line 45. On pp 81-2, it is shown that neither state 3 nor state 4 can be associated with a stationary detonation regime, and only state 2, with a minimum deton velocity, D , remains. The rarefaction wave in the reaction products follows right behind state 2 without overtaking it and without dropping back from it. The velocity of this rarefaction wave is equal to the local velocity of sound c , which coincides with the velocity of the detonation wave, $D - \omega$, relative to the reacting substance

On p 82 of Ref 55, it is shown that regime 4 is impossible only in a free deton wave behind which a rarefaction wave is being generated, but if the formation of rarefaction wave is prevented, regime 4 can

exist. A regime of the type 3 can be obtained by artificial ignition of the gas by exciting, for example, a chemical reaction in the initial state by a sequence of weak electrical sparks

Finally Z & K derived the following equations:

$$pv_0 = 2(k-1)Q, \quad (\text{Eq 11})$$

where: p = pressure of gas; v_0 = specific volume of uncompressed gas; $k = c_p/c_v$, equal to 9/7 for diatomic gases; and Q = chemical energy

Thermodynamic velocity $D = \sqrt{2(k^2-1)Q}$ was already shown as Eq 8

Kinetic energy:

$$\frac{\omega^2}{2} = \frac{k-1}{k+1} Q = \frac{9/7-1}{9/7+1} Q = \frac{Q}{8} \quad (\text{Eq 12})$$

On comparing the pressure in the detonation wave with the pressure which would be developed for an explosion of a given substance in an initial closed volume (such as in a solid steel bomb), the following relation was obtained:

$$p/p' = 2, \quad (\text{Eq 13})$$

which showed that the pressure in the detonation wave exceeded the pressure associated with the explosion by a factor of 2

In the same way the temperature associated with explosion (T') was compared with that of detonation (T)

$$T' = Q/c_v, \quad (\text{Eq 14})$$

where c_v = sp heat at const v of the explosion products

$$T = \frac{2k}{k+1} \cdot \frac{Q}{c_v} \quad \text{and} \quad (\text{Eq 15})$$

$$\frac{T'}{T} = \frac{2k}{k+1} \quad \text{and if } k=9/7 \quad (\text{Eq 16})$$

$$T' = \frac{9}{8}T \quad (\text{Ref 55, pp 84 \& 85}) \quad (\text{Eq 17})$$

Influence of inert ingredients on detonation rates of gases is discussed in Ref 2, pp 145-46. Usually they decrease the velocity, but there are cases when they increase it (if added in small amounts), but only slightly. This increase takes place only when the pre-

sence of inerts decreases the average molecular weight of products of detonation

Table 2
Influence of Inert Components
on Detonation Velocity of Gases

| Mixtures | Detonation Rate, m/sec |
|---|------------------------|
| 2H ₂ +O ₂ | 2819 |
| 2H ₂ +O ₂ +1.5 Ar | 1950 |
| 2H ₂ +O ₂ +3.0 Ar | 1800 |
| 2H ₂ +O ₂ +5.0 Ar | 1700 |
| 2H ₂ +O ₂ +1.5 He | 3100 |
| 2H ₂ +O ₂ +3.0 He | 3130 |
| 2H ₂ +O ₂ +5.0 He | 3160 |
| 2H ₂ +O ₂ +1.0 N ₂ | 2407 |
| 2H ₂ +O ₂ +3.0 N ₂ | 2055 |
| 2H ₂ +O ₂ +5.0 N ₂ | 1822 |
| CO (dried over H ₂ SO ₄) | 1305 |
| CO+1.2% H ₂ O (by volume) | 1676 |
| CO+2.3% H ₂ O | 1703 |
| CO+3.7% H ₂ O | 1713 |
| CO+9.5% H ₂ O | 1693 |
| CO+15.6% H ₂ O | 1666 |
| CO+24.9% H ₂ O | 1526 |
| CO+38.4% H ₂ O | 1266 |

Table 2, which combines values of Tables 4.5 & 4.6 of Ref 56, p 146, shows influence of some of the inert ingredients. As can be seen from this Table, helium being of low at wt (=4) increases the velocity, while He (at wt 39) and nitrogen (at wt 14) always decrease it. Water vapor increases velocity because in mixtures with carbon monoxide it takes part in the reaction:

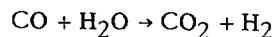

Increase is also caused by small amounts of other hydrogen containing compounds, such as hydrogen sulfide, ammonia, ethylene, etc (Ref 56, pp 145-46)

Refs: 1) D.L. Chapman, PhilMag **47**, 90 (1899) & JCS **76**II, 591 (1891) (Rate of explosion of gases) 2) B. Lewis, JACS **52**, 3120-27 (1930) (Chain reaction theory on the rate of explosion in detonating gas mixtures) 3) B. Lewis & J.B. Friauf, JACS **52**, 3905-20 (1930) (Calculation of rates of explosion in mixtures of hydrogen and oxygen and the in-

- fluence of rare gases) 4) W.A. Bone & R.P. Fraser, *TrRoySoc* **230A**, 363-85 (1932) (Photographic investigation of flame movements in gaseous explns) & *CA* **26**, 1788 (1932) 5) A.S. Sokolik & K.I. Shchelkin, *ZhFizKhim* **5**, 1459 (1934) (Detonation in gaseous mixtures. Variation of the detonation wave velocity with pressure) 6) M.A. Rivin & A.S. Sokolik, *ZhFizKhim* **7**, 571 (1936) (The explosion limits of gaseous mixtures. Expln limits of hydrogen-air mixtures) 7) *Ibid*, **8**, 767 (1936) (Expln limits in carbon monoxide-methane mixts) 8) *Ibid*, **10**, 688 & 692 (1937) (Expln limits of acetylene-air mixts) 9) B. Lewis & G. von Elbe, "Combustion, Flame and Explosion of Gases", OxfordUnivPress, London (1938) (Later editions are listed as Refs 30 & 59) 10) K.I. Shchelkin, *DoklAkadN* **23**, 636 (1939) (On the theory of detonation initiation of gaseous mixts in pipes) 11) Ya. B. Zel'dovich, *ZhEksper i TeoretFiz* **10**, 542-68 (1940) (Theory of propagation of detonation in gases) 12) K.I. Shchelkin, *Ibid* **10**, 823 (1940) (Effect of roughness in a pipe on the initiation and propagation of detonation in gases) 13) Ya. B. Zel'dovich, "Teoriya Gorenii i Detonatsii Gazov" (Theory of Combustion and Detonation of Gases), IzdatAkadNauk, Moscow (1944) 14) W. Jost, "Explosion and Combustion Processes in Gases", McGraw-Hill, NY (1946) 15) Ya.B. Zel'dovich, "Teoriya Udarnykh Voln i Vvedeniye v Gazodinamiku" (Theory of Shock Waves and Introduction to Gas Dynamics), IzdatAkadNauk, Moscow (1946) 16) L.A. Vulis, *DoklAkadN* **54**, 669 & 773 (1946) (On exceeding the velocity of sound in a gas flow) 17) B.V. Aivazov & Ya.B. Zel'dovich, *ZhExper i Teoret Fiz* **17**, 889 (1947) (Formation of an overcompressed deton wave in a constricted pipe) 18) N. Manson, "Propagation de Détonation et de Déflagration dans les Mélanges Gazeux", EditionOfcNatlÉtudesRecherchesAeronautiquesFrançPetrole, Paris (1947) (Engl Transln TIL/T, Nov 1956) 19) S.M. Kogarko & Ya.B. Zel'dovich, *DoklAkadN* **63**, 553 (1948) (On the detonation of gaseous mixtures) 20) V.E. Ditsent & K.I. Shchelkin, *ZhFizKhim* **19**, 21 (1949) (Rapid combustion regime in rough pipes) 21) G.N. Abramovich, "Prikladnaya Gazodinamika" (Applied Gas Dynamics), Gostekhizdat, Moscow (1949) 22) D.J. Berets et al, *JACS* **72**, 1080-86 (1950) (Stationary waves in hydrogen-oxygen mixts); *Ibid*, 1086-91 (1950) (Gaseous detons initiated by shock waves) 23) H.F. Coward, "Explosions in Gaseous Mixtures", pp 961-992 in Kirk & Othmer **5** (1950) (Not found in the later edition of K & O) 24) G.B. Kistiakowsky, "Theory of Detonation of Explosives", pp 948-60 in Kirk & Othmer **5** (1950) (Not found in later edition) 25) G. Taylor, *PrRoySoc* **204A**, 8-9 (1950) & *CA* **45**, 10587 (1951) (Similarity solutions to problems involving gas flow and shock waves) 26) R.M. Davies & J.D. Owen, *PrRoySoc* **204A**, 17 (1950) & *CA* **45**, 10587 (1951) (Pressure measurement in detonating gases by a new pressure-bar technique) 27) R.M. Davies et al, *PrRoySoc* **204A**, 17-19 (1950) & *CA* **45**, 10588 (1951) (Preliminary results on measurements of pressures in detonating gases) 28) W. Döring & G. Schön, *ZElektrochemie* **54**, 231-39 (1950) & *CA* **44**, 10329 (1950) (Detonation velocity of methane and cyanogen in mixtures with O₂ and N₂) 29) A.J. Mootadian & W.E. Gordon, *JChemPhys* **19**, 1166-72 (1951) & *CA* **46**, 1257 (1952) (Initiation of gaseous detons) 30) B. Lewis & G. von Elbe, "Combustion, Flame, and Explosions of Gases", Academic Press, NY (1951) (See also Refs 9 & 59) 31) G.B. Kistiakowsky, *IEC* **43**, 2794-97 (1951) (Initiation of detonation in gases) 32) G.B. Kistiakowsky, *JChemPhys* **19**, 1611-12 (1951) (Density measurements in gaseous detonation waves) 33) Taylor (1952), 80-3 (Detonation in ideal gases); 83-6 [Detonation in real (nonideal) gases and dust clouds] 34) J. Fay, "Initiation of Detonation in 2H₂ + O₂ Mixtures by Uniform Shock Waves", 4thSympCombstn (1952), pp 501-07 35) T.L. Cottrell & S. Pater-son, *PrRoySoc* **213A**, 214-25 (1952) (An equation of state applicable to gases at densities near that of a solid and temperatures far above critical) 36) H.M. Peek

- & Z.W. Zalsburg, *JChemPhys* **20**, 763 (1952) (Equation of state of gases at high temperatures) 37) J.A. Nicholls et al, Univ of Michigan EngrgResInstFinalRept Project **M898** (1953); Air Force Contract No AF 33 (038)-1265 (Gaseous detonations) 38) C.M. Mason et al, "Studies on Gaseous Detonation", Section of USBurMinesProgrRepts on "Detonation and Explosives Phenomena", OrdnProj TB2-0001; Army Proj 599-01-004 (July-Sept 1953; Oct-Dec 1953; Jan-March 1954; April- June 1954; July-Sept 1954; Oct-Dec 1954, Jan-March 1955; April-June 1955; July-Oct 1955 and Oct-Dec 1955) 39) A.L. Bennett, *PhysRev* **92**, 543 ff (1953) (Detonation in gases) 40) B. Greifer et al, "Studies on Gaseous Detonations", USBurMines, Exptl & PhysSciDivRept **1167** (1954) 41) H. Knight & R. Duff, *PhysRev* **94**, 784 ff (1954) (Precision measurement of deton and strong shock velocity in gases) 42) G.B. Kistiakowsky & P.H. Kydd, *JChemPhys* **23**, 271-74 (1955) (The density profile of the rarefaction wave which follows a gaseous detonation was detd by using the technique of x-ray absorpction measurements to follow rapid gas density changes) *Note:* This paper is No VI of the "Gaseous Detonations", series published by G.B. Kistiakowsky et al and was followed by six later papers, the last one being No XII, which appeared in *JChemPhys* **30**, 577-81 (1959) & abstracted in *CA* **53**, 13744 (1959) 42a) YaB. Zel'dovich & A.S. Kompaneets, "Teoriya Detonatsii", Gostekhizdat, Moscow (1955) (Engl transl, see Ref 55) 43) A.L. Bennett & H.W. Wedaa, *PhysRev* **98**, 256 ff (1955) (Detonation in gas at low pressures) 44) S.M. Kogarko, *IzvestAkadNauk, Otdel-KhimNauk* **1956**, N4, 419-26 & *CA* **50**, 14230 (1956) (The possibility of deton of gaseous mixts in cement vessels) 45) H.M. Peek & R.G. Thrap, *JChemPhys* **26**, 740-45 (1957) (Gaseous detonations in mixtures of cyanogen and oxygen) 46) Dunkle's Syllabus (1957-1958), 123-25 (Shock tube studies in gaseous detonations); 125-26 (Spin detonation in gases); 223-29 (Detonation in ideal gaseous expls. Calculation of detonation velocity) (Presented by Dr M.M. Jones, formerly of PicArsn) 47) J.A. Fay & G. Opel, *JChemPhys* **29**, 955-56 (1958) (Two-dimensional effect in gaseous detonation waves) 48) Cook (1958), 44-6 (Ideal detonation in gases); 75-7 (Nonideal deton in gases); 165-66 (Thermal current in gaseous detonations) 49) Baum, Stanyukovich & Shekhter (1959), 144-81 (Elements of gas dynamics); 237-42 (Calculation of detonation wave parameters for gaseous expl mixts) 242-45 (Influence of density on deton velocity in gases) (Pages for some other subjects are given in the text) 50) J.A. Fay, "Two-Dimensional Gaseous Detonations", USDept-Commerce, OfcTechServ, PB Rept **146596** (1959), 19 pp & *CA* **56**, 10436 (1962) 51) J.A. Nicholls et al, "Studies in Connection with Stabilized Gaseous Detonation Waves", 7thSympCombstn (1959), pp 766-72 52) A.K. Oppenheim & R.A. Stern, "On the Development of Gaseous Detonations - Analysis of Wave Phenomena", *Ibid*, pp 837-50 53) F.J. Martin & D.R. White, "The Formation and Structure of Gaseous Detonation Waves", *Ibid*, 856-65 54) C.L. Mader, "Ideal Gas Thermodynamic Properties of Detonation Products", LASL (LosAlamos-ScientificLaboratory) Rept **AECU-4508** (1959) 55) Zel'dovich & Kompaneets (1960) (Engl transl of the Rus book, listed as Ref 42a); pp 132-45 (Effect of mechanical and thermal losses on propagation of gaseous detonation in smooth pipes); 185-91 (Detonation in rough pipes) 56) Andreev & Belyaev (1960), pp 144-48 (Detonation in gases); 222-43 (Theory of gaseous detonations); 506 (Ignition and detonation of gas-air mixts at explosion of various explosives) 57) A.S. Sokolik, "Samovosplamneniye, Plamia i Detonatsiya v Gazakh" (Self-ignition, Flame and Detonation in Gases), IzdatAkadNauk, Moscow (1960) 58) Dunkle's Syllabus (Supplement to Ref 27) (1960-1961), pp 11d & 24e (Gaseous detonations) 59) B. Lewis & G. von Elbe, "Combustion, Flame and Explosions of Gases", Academic Press, NY (1961) (See also Refs 9 & 30) 60) R.K. Lyon & P.H. Kydd, *JChemPhys* **34**, 1069 (1961) (Detonation of acetylene-oxygen

- mixtures) 61) D.R. White, *Physics of Fluids* **4**, 465-80 (April 1961) (The turbulent structure of gaseous detonations) 62) H. Miyama & P.H. Kydd, *JChemPhys* **34**, 2038 (1961) (Expansion waves in gaseous detonations) 63) J.A. Fay, "The Structure of Gaseous Detonation Waves", 8thSympCombstn (1962), pp 30-40 (60 refs) 64) W. Jost et al, "Investigation of the Reaction Zone of Gaseous Detonations", *Ibid*, pp 582-88 65) K.M. Foreman et al, "Parametric Studies of Strong Gaseous Detonations", pp 47-63 in Penner & Williams (1962), 3 refs 66) F.J. Zeleznik & S. Gordon, *AmRocketSoc-J* **32**, 606-15 (1962) & *CA* **63**, 9735-36 (1963) (Calculation of the detonation properties and the effect of independent parameters on gas detonations 67) R.R. Baldwin et al, "The Self-Inhibition of Gaseous Explosions", 9thSympCombstn (1963), pp 184-92 68) D.B. Spalding, "Contribution to the Theory of the Structure of Gaseous Detonation Waves", *Ibid*, pp 417-23 69) A.K. Oppenheim & J. Rosciszewski, "Determination of the Detonation Wave Structure", *Ibid*, pp 424-41 70) J.J. Erpenbeck, "Structure and Stability of the Square-Wave Detonation", *Ibid*, pp 442-53 71) H.G. Wagner, "Reaction Zone and Stability of Gaseous Detonation", *Ibid*, pp 454-60 72) N. Manson et al, "Vibratory Phenomena and Instability of Self-Sustained Detonations in Gases", *Ibid*, pp 461-69 73) M.L.N. Sastri et al, "Optical Studies of the Structure of Gaseous Detonation Waves", *Ibid*, pp 470-73 74) D.R. White & others "General Discussion on Detonation Wave Structure", *Ibid*, pp 474-81 75) A.S. Sokolik, "Self-ignition, Flame and Detonation in Gases", Translation from Russian (See Ref 57), *IsraelProgram for Scientific Translations, Jerusalem* (1963), 458 pp 76) B.V. Voitsekhovskii, V.V. Mitrofanov & M.E. Topchiyan, "Struktura Fronta Detonatsii v Gazakh" (The Structure of Detonation Front in Gases), *IzdatSibirsk-OtdelaAkadNauk, Novosibirsk* (1963), 168 pp; *CA* **61**, 527 (1964) 76a) R.W. Getzinger et al, "Steady Detonations in Gaseous Ozone", 10thSympCombstn (1964), pp 779-84 77) D.R. White & G.E. Moore, "Structure of Gaseous Detonation. IV". "Induction Zone Studies in H₂-O₂ and CO-O₂ Mixtures", *Ibid*, pp 785-95 78) J.H. Lee et al, "Two-Dimensional Unconfined Gaseous Detonation Waves", *Ibid*, pp 805-15 79) E.K. Dabora et al, "The Influence of Compressible Boundary on the Propagation of Gaseous Detonations", *Ibid*, pp 817-30 80) R.E. Duff et al, "Stability of a Spherical Gas Detonation", *USAtEnergyComm UCRL-7895* (1964) 81) G.L. Schott, "Invited Review - Structure, Chemistry and Instability of Detonation in Gases", 4thONRSympDeton (1965), pp 67-77 82) F. Wecken, "Non-Ideal Detonation with Constant Lateral Expansion", *Ibid*, pp 107-16 83) S.K. Aslanov, *DopodiviAkad-Nauk (UkrainRSR)* **1966**(7), 871-74 & *CA* **65**, 19919 (1966) "Criterion of Uni-dimensional Instability of Gas Detonations" (The criterion was derived by using Zel'dovich-Von Neumann model, which represents a detonation wave in an ideal gas as a stationary complex consisting of a shock wave and the front of an instantaneously occurring reaction with a characteristic induction time that follows the shock wave at a definite distance. The results showed that the criterion assumes the form dependent on the intensity of the ignition front, the characteristics of the chem reaction, the index of isentropy, and Mach Number, two indexes referring to gas compressed by the shock wave and the mixt of deton products, resp. For a Jouguet detonation, another equation was derived) 83a) W.M. Sigmon, Jr, *NuclearSciAbstr* **20**(1), 207-08 (1966) & *CA* **65**, 8654 (1966) (Shock testing with HE-initiated gas detonations) 84) J. Brossard et al, "Propagation and Vibratory Phenomena of Cylindrical and Expanding Detonation Waves in Gases", 11thSympCombstn (1967), pp 623-33 85) C.W. Hamilton & G.L. Schott, "Post-Induction Kinetics in Shock-Initiated H₂-O₂ Reactions", *Ibid*, pp 635-43 86) R.I. Soloukhine, "Quasi-Stationary Reaction Zone in Gaseous Detonation", *Ibid*, pp 671-76 87) W.J. Struck & H.W. Reichenbach, "Investigation of Freely Expanding Spherical

Combustion Waves Using Methods of High-Speed Photography", *Ibid*, pp 677-82
 88) R.A. Strehlow et al, "Transverse Wave Structure in Detonation", *Ibid*, pp 683-92
 89a) R.I. Soloukhine, "Nonstationary Phenomena in Gaseous Detonation", *Ibid*, pp 799-807
 89b) A.R. Ubbelohde & G.M. Munday, "Some Current Problems in the Marginal Detonation of Gases", *Ibid*, pp 809-18
 89c) D.H. Edwards, "A Survey of Recent Work on the Structure of Detonation Waves", *Ibid*, pp 819-28
 89d) B.V. Voitsekhovskii et al, "Investigation of the Structure of Detonation Waves in Gases", *Ibid*, pp 829-37
 89e) A.K. Macpherson, "The Three-Dimensional Wave System of Spinning Detonation", *Ibid*, pp 839-50
 89f) R. Cheret & J. Brossard, "Cylindrical and Spherical Detonations in Gases", *Ibid*, Paper 84, p 149 (Abstracts only)
 89g) V.P. Karpov & A.S. Sokolik, "On the Mechanism of Generation of Shock Waves, Their Amplification on Interaction with the Flame, and Transition to Detonation", *Ibid*, Paper 85, p 149 (Abstracts only)
 89h) J.H. Lee et al, "Direct Initiation of Spherical Detonations in Gaseous Explosives", *Ibid*, Paper 86, p 150 (Abstracts only)
 90) G.G. Bach et al, "Direct Initiation of Spherical Detonations in Gaseous Explosions", *Ibid*, 853-64

Detonation (and Deflagration) in Gases; Determination of Ignition Points. H.F. Coward describes in Kirk & Othmer 5(1950), 966-83 the following experimental procedures:
 a) Concentric-tube method (pp 966-67)
 b) Ignition by sudden compression or Shock ignition method (pp 967-69)
 c) Ignition in heated glass (or quartz) bulbs (pp 970-71)
 d) Ignition in "drop-method" apparatus (p 972)
 e) Ignition by hot surfaces (pp 973-74)
 f) Ignition by friction sparks (pp 974-75)
 g) Ignition by flames (pp 975-76)
 h) Ignition by compression waves (pp 976-77) and
 i) Ignition by electric sparks (pp 977-83)

The "drop-method" mentioned above as item d is very simple and much used for easily liquefiable gases as well as for

liquids. The procedure, described in detail by G.S. Scott et al in *AnalChem* 20, 238 (1948), consists of letting a drop (or more) of the liquid fall into a pre-heated flask contg air (or oxygen)

The following table gives values obtd by the "drop method":

Table

| Gas or vapor | Ignition Temp, °C | Lag at Ignition Temp, secs |
|-------------------------|-------------------|----------------------------|
| Propane | 493 | 6 |
| n-Butane | 408 | 5 |
| n-Pentane | 296 | 8 |
| n-Heptane | 230 | 34 |
| n-Octane | 218 | 70 |
| Isobutane | 462 | 14 |
| 2,2,4-Trimethyl-pentane | 434 | 20 |
| Ethylbenzene | 477 | 13 |

It has been noted that some liquids are ignited at much lower temps in the "drop-method" apparatus than when they are vaporized first and their vapors are let into the "concentric-tube" app, described on p 967. The possible danger of expln from spilled liquid in an industrial plant is therefore better assessed by the "drop-method" than by the "concentric-tube" method, as well as being more easily determined (p 972)

Detonation (and Explosion) of Gases, Vapors and Dusts; Development (Transition) from Burning (Combustion) or Deflagration. If an explosive mixture of gas, vapor or dust with air (or oxygen), located in a long pipe closed at both ends, is ignited at one end by a spark (such as from a spark plug), the resulting flame will propagate inside the pipe with an increasing velocity and then, at some distance from the origin of burning, a detonation wave will form. Accdg to experiments of A.S. Sokolik & K.I. Shchekin in Russia and of P. Lafitte in France, as quoted in Ref 7, pp 192-93, the distance from the origin to the place where normal detonation arises diminishes as the initial pressure of the mixture increases, and it

increases as the initial temperature increases. Table VII of Ref 7, p 192 gives distances from the origin of burning to the place where detonation occurs at various initial pressures, while Table VIII on p 193 gives distances at various initial temperatures. These Tables are not reproduced here

The duration of the predetonation period depends strongly on the composition of original mixture and its dilution with inert gases. The addition of a large excess of one of the components increases the duration (and distance) from the origin of burning to the detonation. The duration depends also on the hydrodynamical conditions for which propagation of the flame takes place, on the diameter of the pipe, and on the state of its walls (smooth or rough). Table IX in Ref 7, p 194 shows that distance to detonation in $\text{CH}_4 + 2\text{O}_2$ increases with increased diam of the pipe from 13 mm to 48 mm

Experimental procedures for determination of detonation (or explosion) limits in gases were determined in Russia by M.A. Rivin & A.S. Sokolik and briefly described in Ref 7, p 195. The apparatus consisted of a metallic pipe, 40 meters long, closed at one end and folded as indicated in Fig 1. Diameters varied, but it seems that 13 mm pipe was mostly used for such experiments. The great length of the pipe allowed determination without error the existence of a stationary regime for the propagation wave. In order to be able to observe the propagation wave by one of the "high speed" photographic procedures, described in Vol 2 of Encycl under CAMERAS (pp C13 ff), the pipe was cut in two places, at distances 11 and 32 meters from origin of burning, to allow sections of glass tube, each 100 cm long, to be connected to the pipe. Compositions of mixtures were varied until minimum and maximum concentrations were found. This method permitted the determination, not only of the lower and upper explosion (or detonation) limits (as given in Table A, compiled from Ref 4, p 144 and Ref 7, p 196), but also detonation velocities at various concentrations

As was mentioned in this section, com-

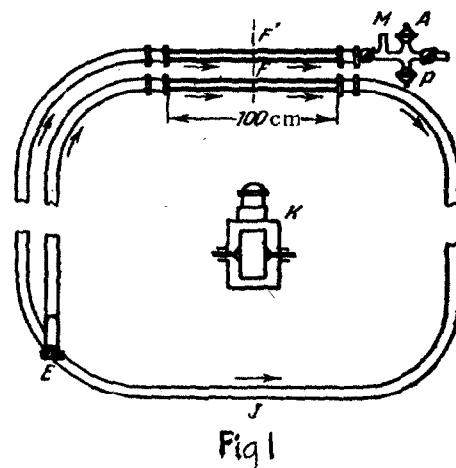

bustion in gases can under certain conditions develop into detonation. This will result when initiation of combustible gas is conducted by detonation of another explosive mixture. In tests, described in Ref 7, pp 135-36, the pipe is divided by a partition into two parts. One part is filled with a high energy detonating gas (such as a mixture of $2\text{H}_2 + \text{O}_2$), while the other part is filled with the mixture to be tested. Just before the test the partition is removed and, as a result of diffusion, there will be formed a zone in which composition of the mixture is between that of the initiating mixt and the specimen mixt. On initiation of $2\text{H}_2 + \text{O}_2$ mixt by a high energy detonator, the resulting detonation wave propagates along the pipe and finally enters the specimen mixture. If the compn of this mixt is within lower and upper detonation limits, it detonates with velocities indicated in Table A. Otherwise it becomes "damped out"

The values reported in Table A are those for detonations conducted in smooth pipes of diam ca 10 cm. The velocities in these cases are not much smaller than the "thermodynamic velocity", $D = \sqrt{2(k^2 - 1)Q}$, where Q is chemical energy and $k = c_p/c_v$. If experiments are conducted in rough pipes, the velocities are lower and in some cases can be as low as 40-50% of thermodynamic values (Ref 7, p 187)

In order to obtain controlled roughness

Table A
Explosion (or Detonation) Limits and
Detonation Velocities of Gases
in Oxygen or Air at Initial Pressure
of One Atmosphere and Room Temperature

| Mixture | % Composition in O ₂ or Air | | Detonation Velocity, m/sec | |
|--|--|-------------|----------------------------|--------------------|
| | Lower Limit | Upper Limit | At the Lower Limit | At the Upper Limit |
| H ₂ -O ₂ | 20 | 90 | 1457 | 3550 |
| H ₂ -Air | 18.2 | 58.9 | 1500 | 2100 |
| CO-O ₂ (dry) | - | 83 | - | - |
| CO-O ₂ (damp) | 38 | 90 | - | 1473 |
| (CO+H ₂)-O ₂ | 17.2 | 90 | 1500 | 2150 |
| (CO+H ₂)-Air | 19 | 58.7 | 1488 | 1690 |
| C ₂ H ₄ -O ₂ | 3.5-3.6 | 92-93 | 1607 | 2423 |
| C ₂ H ₄ -Air | 5.5 | 11.5 | 1675 | 1801 |
| C ₃ H ₈ -O ₂ | 3.2 | 37 | 1587 | 2210 |
| C ₃ H ₈ -Air | 4.2 | 50 | 1509 | 1871 |
| i-C ₄ H ₁₀ -O ₂ | 2.9 | 31.3 | 1595 | 2188 |
| Ether-O ₂ | 2.7 | 40 | 1593 | 2323 |

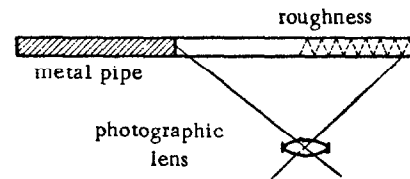

Fig 2

in the pipes, it was proposed by K.I. Shchelkin & V.E. Ditsent to insert helical wires of various diameters in glass pipes. By doing this it was possible to alter the hydrodynamic impedance coefficient, which depends on the wire diameter and on the number of turns in the wire per cm of pipe. In this experiment (See Fig 2), a detonation wave arising in a section of metal pipe ca 1 meter long, is subsequently propagated

along a glass pipe ca 2 m long. In the 2nd half of the glass pipe is placed the helical wire to create roughness. The propagations of detonation in smooth and rough sections of the glass pipe are recorded photographically on the same film and corresponding velocities are calculated. Experimental values obtd by Shchelkin are given in Table V, p 187 of Ref 7, which is partly reproduced here as Table B

Table B
Effect of Roughness on the
Detonation Velocity of Various Mixtures

| Mixture | Pipe Diameter, cm | r | n | D _s , m/sec | D _r , m/sec | $\frac{D_r}{D_s}$ in % |
|---|-------------------|------|-----|------------------------|------------------------|------------------------|
| 2H ₂ +O ₂ | 10.0 | 0.25 | 3.6 | 2767 | 2353 | 85.5 |
| | | 0.43 | 2.4 | 2820 | 1608 | 57.0 |
| 2H ₂ +2O ₂ | 7.0 | 0.20 | 5.1 | 2853 | 2330 | 81.7 |
| | | 0.29 | 3.9 | 2820 | 2170 | 77.0 |
| | | 0.43 | 3.2 | 2795 | 1859 | 66.5 |
| 2.07H ₂ +O ₂ | 4.5 | 0.31 | 5.0 | 2940 | 1760 | 59.9 |
| | | 0.44 | - | 2974 | 1685 | 56.7 |
| C ₂ H ₆ +3.5 O ₂ | 10.0 | 0.20 | 4.2 | 2110 | 1872 | 88.7 |
| | | 0.30 | 2.5 | 2050 | 1755 | 85.7 |
| | | 0.43 | 2.4 | 2142 | 1478 | 68.8 |

In Table B, the value r is the ratio of the diam of the wire to the radius of the pipe, n is the number of turns of the helix per cm along the pipe, D_s is the detonation velocity in the smooth part of the pipe and D_r is the velocity in the rough part

Refs: 1) Ya.B. Zel'dovich & A.S. Kompaneets, "Teoriya Detonatsii", Gostekhizdat, Moscow (1955) (Engl transl, see Ref 7)

2) Dunkle's Syllabus (1957-1958), Sessions 9, 10 & 11: "Development of Detonation from Deflagration"

3) A.K. Oppenheim & R.A. Stern, "On the Development of Gaseous Detonation", UnivCalifTechNote DR1 (1958), Berkeley, Calif, Contract No AF 49(638)-166 and 7thSympCombstn (1959), pp 837-50

4) Baum, Stanyukovich & Shekhter (1959), 417-28 (Transition of combustion to detonation in gases)

5) G.D. Salamandra et al, "Formation of Detonation Wave During Combustion of Gas in Combustion Tube", 7thSympCombstn (1959), pp 851-55

6) Andreev & Belyaev (1960), 141-44 (Transition of burning to detonation)

7) Zel'dovich & Kompaneets (1960), 135-36, 186-87 & 191-96 (Development of detonation from combustion)

8) A.S. Sokolik, "Samovosplamneniye, Plamia i Detonatsiya v Gazakh", IzdatAkadNauk, Moscow (1960); translated under the title "Self-Ignition, Flame and Detonation in Gases", Jerusalem (1963)

9) Dunkle's Syllabus (Supplement to Ref 2): "Development of Detonation from Deflagration", Sessions 9, 10 & 11

10) R.W. Gipson & A. Maček, "Flame Fronts and Compression Waves during Transition from Deflagration to Detonation in Solids", 8thSympCombstn (1962), 847-54

11) K.K. Andreev & S.V. Chuiko, ZhFizKhim 37(6), 1304-10 (1963) & CA 59, 6190 (1963) (Transition of combustion to deflagration in expl substances; combstn of powd expls at high constant pressures)

12) A.J. Landerman et al, "On the Generation of a Shock Wave by Flame in an Explosive Gas", 9thSympCombstn (1963), 265-74

13) A.R. Ubbelohde & G.M. Munday, "Some Current Problems in the Marginal Detonation of Gases", 12thSympCombstn (1969), 809-18

14) V.P. Karpov & A.S. Sokolik

"On the Mechanism of Generation of Shock Waves, Their Amplification on Interaction With the Flame and Transition to Detonation", 12thSympCombstn, Poitiers, France (1968) (Pub 1969), pp 149-50, Paper 85 (Abstracts) (Paper not found in published Symposium) [See also Refs under Detonation (and Explosion) in Gases"]

Detonation, Geometrical Model Theory of

The Langweiler concept of the detonation wave shape and its density props was formulated in 1938 (Ref 3). It is described by Cook (Ref 8, pp 91-2) who bases his *geometrical model theory* on the concept of Langweiler

Accdg to Cook, Langweiler assumed for the plain-wave deton behind the wave front a simplified constant $\rho(x)$ (density-distance) and $W(x)$ (particle velocity-distance) contour followed by a sharp (presumably discontinuous) rarefaction. He gave as the velocity of the rarefaction front the value $(D+W)/2$, where (D) is detonation velocity. Then he deduced that in an explosive of infinite *lateral extent*, the compressional region or detonation head of the wave should grow in thickness in accordance with the equation:

$$s = 3Dt/8$$

where (t) is time in seconds

In the Langweiler concept no influence on velocity would be felt by any finite reaction zone of length less than $3Dt/8$.

Moreover, for any reaction zone length $a_0 < s < 3Dt/8$, the velocity at the distance (Dt) from the point of initiation would be ideal ($D=D^*$). Only for $a_0 > s$ would the detonation become nonideal

Cook (Ref 8, p 91) considered the influence of finite charges on Langweiler's simplified model by postulating the existence of *lateral rarefaction waves* (called "release waves" by E.M. Pugh et al) from the sides of the charge which themselves were assumed to converge on the central axis also with a sharp or discontinuous front of the same velocity as in Langweiler rarefaction from the rear. This model there-

fore predicted the development of a steady-state detonation head after propagation of the wave front in unconfined cylindrical charges a distance of about three and one-half charge diameters ($L_m/d=3.5$) from the point of initiation. The detonation head would develop thru stages of successive truncated cones of base to apex height about $3Dt/8$, reaching a fully developed, conical detonation head of height the order of one charge diameter. In confined charges the steady-state detonation head should be somewhat larger because confinement would lower at least the initial velocity of the release waves from the side

The Langweiler model was attacked by Kistiakowsky & Kydd (Ref 6) on the basis that the rarefaction wave cannot remain abrupt, as claimed by Langweiler, but must spread out in time. All classical theories of the deton wave front assume that rarefaction begins immediately behind the deton front

The geometrical model of Cook (Ref 8, pp 125-28) is based on the detonation head having flat density-distance $\rho(x)$ and particle velocity-distance contours behind the

wave front as in the Langweiler model. In the geometrical model the velocity of detonation D is determined by energy released ahead of a critical region, a distance h behind the wave front and lying along the axis of a cylindrical charge. This critical region will, in general lie either at the end (ideal detonation) or within the actual reaction zone (nonideal detonation). It will move closer to the shock front the poorer the confinement, owing to the influence of the confinement on the initial velocity of the lateral rarefaction waves

The influence of the reaction-zone length a_0 in this model is simply the following: The effective "Chapman-Jouguet (CJ) point" on the cylindrical charge axis always coincides with the beginning of the sharp rarefaction region outlined by the heavy line in Fig 5.2 (Ref 8, p 94). If a_0 is less than or equal to the distance from the wave front to this point on the charge axis, detonation will be ideal. But if it is greater than the distance h , detonation will be nonideal

In this model nonideal detonation is restricted to *effective* reaction-zone length of $a'_0=3/8(Dt)$ for $L < L_m$ and to $a'_0=h_m=d'$

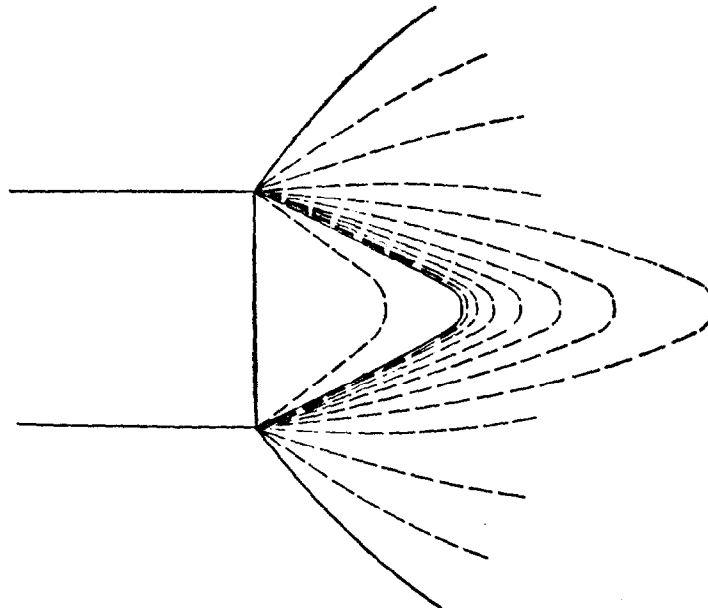

Fig 5.2. The Phenomenalistic Steady-State Detonation Head in an Unconfined Cylindrical Charge

for $L \geq L_m$, where h_m is the maximum height of the fully developed detonation head corresponding to the height of the steady-state detonation head (spherical) cone in unconfined charges. The meaning of other symbols are: t =time, L =charge length, L_m =max effective chge length, and d^1 =effective diam

The velocity-determining streamline is always the axial one, since the wave will travel at the speed determined by the maximum values of P_2 (pressure) and W_2 (particle velocity) on the C-J plane

If the exact law for the explosive is known, the geometrical model may be made quantitative to give $D(L, d)$ and when Eyring et al (Ref 5) formulated the so-called *surface-burning model* for solid expls, it was adopted in the geometrical model. The resulting calcns were in good agreement with experimental observations for all types of nonideal expls, except AN-fuel expls

Application of the Eyring surface-burning model for use in the geometrical model in the case of condensed expls is described in detail by Cook (Ref 8, pp 126-37)

Accdg to Roth (Ref 4) the geometrical theory is essentially the theory developed by him and described in his thesis (Ref 1). Roth also pointed out that this theory is mentioned in a paper by Wöhler & Roth (Ref 2) who also made use of the *surface-erosion* concept in describing reaction rates in the deton of expls. Roth lacked the necessary proof at that time to justify exploitation of his theory

Refs: 1) J.F. Roth, "Über die Prüfung der Initialwirkung von Sprengkapseln", Dissertation, Technische Hochschule, Darmstadt (1928) (A theory similar to the geometrical model, Chapter 8) 2) L. Wöhler & J.F. Roth, SS 29, 9 (1934) 3) H. Langweiler, ZTechPhysik 19, 271 (1938) 4) J.F. Roth, Nobel Hefte 22, 246 (1946) 5) H. Eyring et al, ChemRevs 45, 69 (1949) (Surface-erosion model as applied to deton) 6) G.B. Kistiakowsky & P.H. Kydd, "The Measurement of Density Changes in Gaseous Detonation", 2ndONRSympDeton (1955), 69-97 & JChemPhys 25, 824-35 (1956)

7) Dunkle's Syllabus (1957-58), pp 337-38 (Release wave theory) 8) Cook (1958), pp 91-92, 125-37)

Detonation in Granular Explosives. In addition to the effects of higher density associated with condensed expls, there are in granular expls addnl effects due to their inhomogeneity. One parameter affected by the nature of these materials is the length of the reaction zone. The longer it is, the lower will be the deton velocity and the less stable the wave. This is because the pressure of the detonation front will decrease as the zone becomes longer. The zone may be long for either mechanical or chemical reasons and it tends to lengthen when the expl is coarse-grained. Since the reaction proceeds from the grain surface inward, a large grain would still be decompg after a small one has disappeared. Also, perfect crystals detonate with a longer reaction zone than imperfect ones, probably because the imperfections provide sites for "hot spots" which facilitate initiation. Finally, the length of the reaction zone seems to be related to the thermal stability of the explosive. Accdg to Gilman (Ref 3), all of these factors are related to shock sensitivity

Analysis of the effect of grain size on the behavior of the deton wave presents some theoretical difficulties (Ref 2) and can only be approximately achieved if some assumptions are made as discussed in Refs 4 & 5

Accdg to Jones & Mitchell (Ref 1), in granular solid expls (TNT or Tetryl) as in some liquid and gelatinous expls, an initial unstable phase of deton may change abruptly to a higher level of deton. The length of the initial slow phase ("pre-detonation phase") decreases with increasing strength of the initiator and may decrease to zero with high density compressed cartridges. On the other hand, its duration is increased in a narrow cartridge or when a sufficiently coarse grist of expl is used, so that a uniform and stable low-velocity deton may be

produced in which some of the expl remains undecompd

Refs: 1) E. Jones & D. Mitchell, *Nature* **161**, 98-99 (1948) & *CA* **42**, 3179 (1948)
 2) Taylor (1952), 111-15 3) Gilman **4** (1953), 961 4) S. Paterson, p 675 in the 5thSympCombstn (1955) & *CA* **49**, 16437 (1955) 5) Dunkle's Syllabus (1957-58), 229-30 (as presented by Dr R.C. Ling)
 6) G.E. Hauver, "Pressure Profiles in Detonating Solid Explosives", 3rdONRSymp-Deton (1960), pp 241-52 6a) M.J. Urizar et al, "The Detonation Velocity of Pressed TNT", *Ibid*, pp 327-56 7) M.A. Cook et al, "Measurements of Detonation, Shock, and Impact Pressures", *Ibid*, pp 357-85
 8) G.E. Seay & L.B. Seely, Jr, "Initiation of Low-Density PETN Pressing by a Plane Shock Wave", *Ibid*, pp 562-73 9) E.L. Kendrew & E.G. Whitbread, "The Transition from Shock Wave to Detonation in 60/40 RDX/TNT", *Ibid*, pp 574-83 10) S.J. Jacobs et al, "The Shock-to-Detonation Transition in Solid Explosives", 9thSymp-Combstn (1963), pp 517-29 11) G.E. Seay, "Shock Initiation of Granular Explosives Pressed to Low Density", *Ibid*, pp 530-35 12) F.J. Warner, "The Initiation of Detonation in Solid Explosives", *Ibid*, pp 536-44 13) G.K. Adams, "Theory of Initiation of Detonation in Solid and Liquid Explosives", *Ibid*, pp 545-52 14) W.E. Gordon, "Detonation Limits in Composite Explosives", 10thSympCombstn (1965), pp 833-38

Detonation (and Explosion), Hazards (Dangers) of. This subject is discussed in Vol 3, p C5-L under the title "Danger of Handling Explosives" and also in the following *refs:*

Refs: 1) G. Barbaras et al, *JACS* **70**, 877 (1948) & *CA* **42**, 3572 (1948) (Expln hazards in evaporating ethereal soins of hydrides of Al, Li, Li-Al, Na, etc) 2) L. Médard et al, *RévMet* **46**, 549-60 (1949) & *MP* **32**, 179-96 (1950); *CA* **44**, 330 (1950) & **47**, 9013 (1953) (Danger of expln from perchloric acid - acetic anhydride mixts used in electrolytic polishing baths) 3) R.

Huisgen et al, *Ann* **562**, 137-62 (1949); **573**, 163-81 (1951); **573**, 181-95 (1951); **574**, 157-201 (1951) and **575**, 174-216 (1952) (In studying the reactions betw nitroso-acylamines and diazo esters several expl compds were prepd. Some reactions involved explosion hazards) 4) F. Bucci, *AnnChim* (Rome), **41**, 587-93 (1951) & *CA* **47**, 3443 (1953) (Reactions of alkali nitrites with some org amines, such as urea may result in explns) 5) G. Armistead, *ChemEngr-Progress* **48**, 5-10 (1952) & *CA* **46**, 2298 (1952) (A review of expln hazards) 6) J.J. Horan et al, *AeronautEngrRev* **11**, No 3, 37-45 (1952) & *CA* **46**, 7331 (1952) (Reduction of gun-gas expln hazard in combat aircraft) 7) A. Seher, *Ann* **575**, 153-61 (1952) & *CA* **47**, 3800 (1953) (Prepn of some derivs of vinylcarbamic acid involves expl hazards) 8) A.E. Arbuzov & V.M. Zoroastrova, *IzvestAkadN, OrdElKhimNauk* **1952**, 453.58 & *CA* **47**, 4833 (1953) (Hazards in study of reactions of 1,2-diethylphosphorus acid chloride are reported) 9) B.A. Ribeiro, *ArquivFacHig e SaúdePúbl, Univ São Paulo* **6**, 61-84 (1952) & *CA* **47**, 9013 (1953) (Ignition and expln of some anesthetic agents; a review with 53 refs) 10) R.M. Adams, *C&EN* **31**, 2334 (1953) & *CA* **47**, 837 (1953) (Expln hazard in drying methyl ethers with Li-Al hydride) 11) J.N. Eisendrath, *C&EN* **31**, 3016 (1953) & *CA* **47**, 11737 (1953) (Danger of expln on heating 1-methyl-3-nitro-1-nitrosoguanidine in a closed system) 12) Anon, *C&EN* **31**, 3320 (1953) & *CA* **47**, 11737 (1953) (Titanium alloys exposed to red fuming nitric acid form compds liable to detonate) 13) R. Criegee, *AngChem* **65**, 398-99 (1953) & *CA* **47**, 11737 (1953) (Danger of expln on vacuum distillation of t-butylperbenzoate, and on handling ethylene ozonide) 14) Anon, "Military Explosives", *TM* **9-1910** (1955), 52 (Table XI entitled "Classification of Explosives with Respect to Hazard From Electric Sparks". Dangerous expls are: BkPdr, DADNPh, EC Powder, Expl "D", LA, LSt, MF, Tetracene, Tetryl, Tetrytol & Ungraphited Smokeless Propint. Non-

- dangerous expls: Bullseye Powder, Comp B, Comp C-3, Graphited Smokeless Propnt, PETN, RDX & TNT 15) Sax(1957). See later edition, Ref 24 16) Cook(1958), 6 (Table 1.4 lists "relative hazards" of various industries, including BkPdr and HE plants); 7 (Table 1.5 lists ten largest accidental explns covering the period between 1918 & 1947) 17) H.G. Dorsett Jr et al, "Laboratory Equipment and Test Procedures for Evaluating Explosibility of Dusts", USBurMines **RI 5624**(1960), 21 pp
- 18) E.L. Lichfield, "Minimum Ignition - Energy Concept and Its Application to Safety Engineering", USBurMines **RI 5671**(1960), 10 pp 19) J.M. Kuchta et al, "Flammability and Detonability Studies of Hydrogen Peroxide Systems Containing Organic Substances", USBurMines **RI 5877**(1961), 20 pp 20) CondChemDict(1961) lists under individual compds, such as acetone, p 8-R, "Danger" and "Shipping Regulations" prescribed by "The Interstate Commerce Commission" and by "The Bureau for the Safe Transportation of Explosives and Other Dangerous Articles" 21) M. Jacobson et al, "Explosibility of Dusts Used in the Plastics Industry", USBurMines **RI 5971**(1962), 30 pp 22) M.G. Zabetakis et al, "Explosion Hazards of Diethyl Ether", USBurMines **RI 6051**(1962), 14 pp 23) D. Burgess & M.G. Zabetakis, "Fire and Explosion Hazards Associated with Liquefied Natural Gas", USBurMines **RI 6099**(1962), 33 pp 24) Sax(1963), 166 (Dust explns); 167 (Salt-bath explns); 179 (Expls & flammable materials); 184 ff (Explosives) 25) J.L. Common, Indicator (April 1964), p 15 (An expln results when furfuryl alc is reacted with cyanoacetic acid) 26) R. Scott Jr, C & EN **45**, No 21 (15 May 1967), p 5 (Rept of an expln of a mixt of boron trifluoride-ethyletherate & lithium aluminum-hydride in a lab attempt to prep Diborane gas) 27) A.I. Rachlin, C & EN **45**, No 38 (4 Sept 1957), p 32 (The antibiotic Myxin decomps violently when heated to combustion) 28) Anon, "Military Explosives", **TM 9-1300-214 / TO 11A-1-34**(1967), pp 2-7 to 2-8 (Care & precautions in handling expls), pp 17-1 to 17-3 (Shipping regulations) (See Ref 14, which is an earlier edn of this manual) 29) J.L. Burmeister & E.A. Hosegood, C & EN **46**, No 8 (19 Feb 1968), p 39 [Rept an expln hazard exists when phenyl isocyanate is substituted for acetonitrile in a reaction that has proven useful for introducing poorly coordinating ligands into the cobalt(III) coordination sphere. See H. Taube et al, InorgChem **5**, 1091 (1966)] 30) J. Terebey, C & EN **46**, No 9 (26 Feb 1968), p 38 (Repts Nitrogen Triiodide - easy to prep from iodine & ammonia - but highly expl when dry; it detonates at the slightest touch) 31) H.D. Moshenrose & H.L. Tracy, Ibid, p 38 (Mixts of finely divided Ba & halogenated hydrocarbons which detonated in impact sensitivity tests: monofluorotrichloromethane, trichlorotrifluoroethane, CCl₄, trichloroethylene, and tetrachloroethylene) 32) A.R. Stein, C & EN **46** (21 Oct 1968), p 7 (Repts expln of methyl isonitrile during distillation when pot was allowed to go dry) 33) E.C. Ashby, C & EN **47** (6 Jan 1969), p 9) (Repts expln of dry potassium aluminum hydride, K₃AlH₆, after several months storage; recommends always prepg fresh samples and only short-term storage under a dry inert diluent)
- Detonation Head and Its Development.* See under Detonation (and Explosion), Initiation (Birth) and Propagation (Growth or Spread) in Explosive Substances
- Detonation Head Model.* See under Detonation (and Explosion), Initiation (Birth) etc
- Detonation (and Explosion) by Heat, Flame or Spark.* See under Detonation (and Explosion), Initiation (Birth) etc
- Detonation, Heat Pulse Phenomenon in.* See under Detonation, Flash-Across, Heat Pulse and Hypervelocity Phenomena
- Detonation, Heat Sensitization of Explosives and Memory Effect.** It has been known for some time that certain expls exhibit a

form of heat sensitization known as the "memory effect" (Refs 4 & 5). This memory effect manifests itself thru the apparent additivity of the induction periods prior to ignition. Thus, an expl which is heated at a given temp and explodes in time t_1 , can also be heated at this temp for a shorter time t_2 , then cooled, and subsequently reheated at this temp to explode at time t_3 such that

$$t_1 = t_2 + t_3$$

Ubbelohde (Ref 5) found that the total induction period of Lead Azide which is heated at a given temp T is practically the same whether measured in one or more stages

Jones & Jackson of Picatinny Arsenal (Ref 6) carried out experiments using the same procedure as that of Ubbelohde et al (Ref 4) except that a Cu rather than an Al sample holder was used. They performed two types of experiments: a) measurements of the induction period as a function of temp for several common expls and b) examination of these expls to det which of them show the "memory effect". Jones & Jackson reported that the memory effect is not found with all primary expls (eg Tetracene) and it is found with some HE's, but not all. Some of the props which might

be expected to play a part in this phenomenon are mp, activation energy, and the nature of the slow thermal decompn of the particular expl. The data obt'd by Jones & Jackson are shown in the following Table

The quantities E & B were computed from the relationship

$$\log_{10} t = -\frac{E}{4.57T} + \log_{10} B$$

where t = induction period in seconds at temp T, E = activation energy and B = a constant analogous to the frequency factor

Jones & Jackson (Ref 6) consider that the most satisfactory explanation of this "memory effect" is found in the work of Semenov (Refs 1 & 2) who considered these reactions as autocatalytic processes. Semenov showed how an isothermal acceleration can occur in such a manner that an explosion will result after a certain minimum rate has been reached. Jones & Jackson concluded that the memory effect is caused by either an autocatalytic or a chain reaction and is of more general occurrence than had been hitherto realized

Parlin et al (Ref 3) treated the thermal decompn of solid expls as a first order reaction and arrived at an explicit expression for the induction period

Hess & Ling (Ref 7) describe the memory

Properties of Explosives Studied

| Explosives | E Kcals/mole | +log ₁₀ B | Shows Memory Effect? | MP(°C) | Kinetics of Thermal Decomposition |
|----------------------|-----------------|----------------------|----------------------------|----------|---|
| Lead Styphnate | 32.3 | -11.59 | Yes | explodes | autocatalytic |
| DDNP | 35.4 | -15.75 | Yes | 158 | autocatalytic |
| Tetracene | 47.5 | -23.09 | No | explodes | ? |
| PETN | 30.2 | -12.08 | Yes | 141.3 | autocatalytic |
| Tetryl | 14.4 | - 5.02 | Yes | 129.5 | autocatalytic |
| RDX | 21.6 | - 7.79 | No | 204.1 | unimolecular |
| HMX | 18.3 | - 6.24 | No | 280 | unimolecular |
| Haleite | 18.7 | - 8.12 | Yes | 177.3 | autocatalytic above 163°C |
| Picric Acid | 15.4 | - 4.93 | No | 122.5 | autocatalytic |
| Lead Azide | 41 | -13.97 | Yes | | autocatalytic |
| Mercury Fulminate | 25.3 | -10.76 | Yes | | autocatalytic |

effect analytically in terms of the following kinetic assumptions: 1) for a first order approx loss of heat by conduction can be neglected, and 2) thermal initiation of expls is closely related to the autocatalysis involved in a solid decompn reaction. They derived a mathematical treatment which provides a theoretical relation between the memory effect in an expl and its autocatalytic decompn, as evidenced by the validity of the additivity equation:

$$t = t_1 + t_2 + \dots$$

They also showed that true additivity of induction periods is only a special case of the memory effect in general
Refs: 1) N.N. Semenov, "Chemical Kinetics and Chain Reactions", Chap 17, Clarendon Press, Oxford (1935) 2) N.N. Semenov, *Uspekhi FizNauk* **23** (3), 251-92 (1940) 3) R.B. Parlin et al, "The Theory of Explosion Initiation", **OSRD 2026** (Nov 1943) 4) J.L. Copp et al, *PhilTr* **241A**, 197 (1948) 5) A.R. Ubbelohde, *Research* **3**, 204 (1950) 6) M.M. Jones & H.J. Jackson, *Explosivst* **9**, 177-79 (1959) 7) W.R. Hess & R.C. Ling, *3rd ONRSymp Deton* (1960), pp 42-49 (On the memory effect in the thermal initiation of expls)

Section 5 DETONATION (EXPLOSION, DEFLAGRATION, COMBUSTION AND FORMATION), HEATS OF

Heat of Formation of a Compound (Q_f or H_f) (*Bildungswärme* in Ger) is the energy evolved in the chemical reaction which would form a given quantity (usually 1 mole) of the compound in its standard state, from its elements; the latter being in the state in which they normally exist at ordinary temperature. The reaction is usually considered to occur under a constant pressure, or rather fugacity, of 1 atmosphere. Hence the *heat of reaction* is equal in magnitude to the standard enthalpy change, but of opposing sign. Heats of formation can be either positive or negative. In the former, the heat is liberated during formation and the compd is

exothermic (eg CO_2 has H_f positive equal to 94.0 kcal/mole, either at constant pressure or volume); in the latter, the heat is absorbed during formation and the compd is called *endothermic* (eg HI has H_f negative equal to 6.0 kcal/mole at const pressure). For exothermic compds the enthalpy change is negative, whereas for endothermic compds it is positive

The energy evolved, as an exothermic reaction is actually carried out, may appear in many forms, but for purposes of measurement it is usually obtained in the form of heat. As in any chemical reaction, the energy released in an explosion exists beforehand, in potential form, as the binding energy of chemical bonds. Breakage of such bonds in an inert compound may occur on application of at least binding energy, but such breakage in an expl compd leads to formation of new bonds with the release of a greater quantity of energy. Summing up the energy of all of the bonds in a compd gives its *atomization energy*, Q_a (Refs 30 & 50). Thus the molecules of an explosive may be thought of as first raised to a higher energy level thru input of a *heat of atomization* to break their interatomic bonds; then the atoms rearrange into molecules of products, releasing a larger quantity of heat and dropping to an energy level lower than the original. Net evolution of energy is therefore positive. Admittedly this possible thermodynamic path is not usually the "kinetic path". For instance, the reaction may take place in several stages involving complex systems of reaction chains etc [See under Detonation (and Explosion), Chain Reactions in]. Nevertheless, the energy evolved depends only on the initial and final states and not on intermediate ones. Once the reaction is completed, the net heat evolved is exactly the same as if the reactant molecules were first dissociated into their atoms, and then reacted directly to form the final products (Hess' Law). If a compd be formed directly from the atoms, the heat of atomization (Q_A) which was required to generate them from the molecules

of their elements is recovered; also a further quantity of heat is evolved, which is equal to the heat of formation of the new molecule from the molecules of its elements. Thus the heat of atomization of the new compound would be $(Q_A + Q_F)$. The heat of formation (Q_F) of a compd is equal in magnitude but opposite in sign to enthalpy change on formation, and may be either positive or negative. Even if (Q_F) is positive a further reaction may be possible, as in the case of many expl compds, with release of still more energy, such as in the heat of explosion or detonation. If (Q_F) is negative, as in endothermic compds, the heat of explosion exceeds the heat which would be released by an explosive reaction of the molecules of its elements to form the same products (Ref 50)

It might be interesting to note, that as early as 1780, it was shown by Fr scientists A.L. Lavoisier & P.S. Laplace that the heat of formation is equal to the heat required to decompose a compound into its elements, which they called *heat of decomposition*.

The heat of formation of an organic compound is equal to the sum of the heats of formation of the products of combustion (CO_2 , H_2O , N_2 , SO_2 etc), minus the heat of combustion of the compound, as given in tables

For instance, the heat of formation of methane may be calculated as follows: The heat of combustion of methane is given in Ref 8, p 264 as 212 kcal/mole. The heats of formation of the products of reaction: $\text{CH}_4 + 2 \text{O}_2 = \text{CO}_2 + 2 \text{H}_2\text{O}$ are equal to -94.05 for CO_2 and -34.19 for $\frac{1}{2} \text{H}_2\text{O}$. This gives a total: $-94.05 + (-34.19) \times 2 = -230.8$ for the heat of formation (Q_F) of products of combustion, CO_2 and H_2O , and $-230.8 + 212 = -18.8$ kcal/mole vs -18.4 given in Ref 8, p 296

Note: In view of the uncertainties introduced into the calculation of heats of formation from heats of combustion of all but the simplest organic molecules, it has been found simpler and more reliable to measure directly the heats of certain types of reactions of theoretical interest, instead of

the heats of formation of the individual substances involved. These investigations have been carried out by G.B. Kistiakowsky and coworkers beginning in 1935 as quoted by Wenner (Ref 17, p 50)

Values for heats of formation of explosives and propellants are given by Schmidt (Ref 8), Blatt (Ref 22b), Tomlinson & Sheffield (Ref 41a) and in the Table located here following "Heat of Explosion and Heat of Detonation"

Some values may be found in Lange's and Chemical Rubber Co Handbooks, Landolt & Börnstein Tables, International Critical Tables, etc (Refs 15, 17, 22, 41, 42, 43 & 44) *Heat of Combustion* (Q_C or H_C) (Verbrennungswärme in Ger). It may be defined as total heat evolved when a given quantity of a substance is completely oxidized by being caused to react in an excess of oxygen. The resulting products, such as CO_2 , H_2O , SO_2 , Al_2O_3 , Fe_2O_3 , CuO , etc are of the highest stage of oxidation. Determinations are usually made in a constant volume calorimetric bomb at a pressure of 25 or 30 atmospheres and can be considered to give the internal energy change (ΔE). They must be corrected to constant pressure at 1 atm (as will be explained under "Heat of Explosion"), to give the enthalpy change (ΔH). This correction is advisable for comparison with the literature, which gives changes in enthalpy more often than in internal energy (Ref 40, p 248)

If an explosive (like TNT) which does not contain in its molecule sufficient oxygen for complete oxidation (See "Available Oxygen" in Vol 1 of Encycl, p A515) is fired in a calorimetric bomb without adding extra oxygen, it forms products like CO , C , H_2 , CH_4 , FeO , Cu_2O , etc and its liberated heat is known as the *heat of explosion*. If products of explosion would be isolated and then burned in a gas calorimeter in presence of sufficient oxygen to form substances like CO_2 , H_2O etc, the heat so evolved added to the heat of explosion will be equal to the heat of combustion. This means that the heat of combustion is higher than the heat of explosion

Heats of combustion can be calculated if the heats of formation of its elements are known. The heat of combustion of an endothermic compound is greater, and that of an exothermic is less than the sum of the heats of combustion of the elements from which it was formed

The value of heat of combustion (Q_C) can be given either in kilogram-calories per mole (kcal/mole) or calories per gram (cal/g), which is the same as kcal/kg. The value can be either at constant volume (Q_C^V) or constant pressure (Q_C^P)

A great deal of our present thermochemical knowledge goes back to the data of Thomsen & Berthelot and Berthelot & Matignon, as described in Refs 1 & 2; but more than a hundred years prior to that, ca 1780, Lavoisier & Laplace published some important work on thermochemistry. Later in this century the following scientists made important contributions to this branch of science: Abernathy (Ref 3), Kharash (Ref 4), Rinkenbach (Refs 5 & 21), Ostwald & Luther (Ref 6), Kassatkin & Planovskii (Ref 7), Schmidt (Ref 8), Rossini (Refs 9 & 12), Huffman & Ellis (Ref 10), Kistiakowsky (Ref 10a), Bichovsky & Rossini (Ref 11), de Paw (Ref 13), Tonegutti (Ref 14), Richardson & Parks (Ref 16), Kistiakowsky (Refs 18 & 20), Prosen & Rossini (Ref 19), Corner (Ref 24), Roth (Ref 24a), Taylor et al (Ref 25) and Physical Research Laboratories at US Bureau of Mines, Bruce-

ton, Pa, and at Picatinny Arsenal, Dover, NJ
Results of work at PicArnsn are described in Technical Reports (PATR's) listed here after Ref 50

As was mentioned already, heats of combustion can be determined either experimentally or by calculation, the latter method being slightly less accurate than the former. The experimental methods may be subdivided into those employing the "universal burner (or gas) calorimeter" or the "bomb calorimeter". The former method is applicable only to gases or to substances easily volatile at room temperature, whereas the latter method is applicable to liquids and solids

A brief description of calorimeters is given in Vol 3 of Encycl, pp C10 to C12, but the procedure was not given

The procedure employed at the Physical Research Lab of Picatinny Arsenal, using bombs especially designed for testing explosives and propellants by the Parr Instrument Co of Moline, Ill (Ref 26a), has been as follows:

Procedures:

- a) Place 1 ml of water in the bottom of the bomb and introduce a lg sample (or less for some HE's) into a cup suspended from wires attached to the head (cover) of the bomb. Insert inside the sample a piece of thin iron wire (fuse) and connect its ends with two electric terminals found in the head of the bomb
- b) Replace the head and fill the bomb with oxygen until a pressure of 25 atmospheres is indicated by the gage. Close the valve
- c) Place the bomb inside a calorimeter containing about 2000 ml of water at a temperature about 1° below room temperature. Close the calorimeter and stir the water to establish an equilibrium inside the calorimeter. Read the temperature to 0.001° on a Beckmann thermometer provided with a cathetometer
- d) Close the electrical ignition circuit momentarily to fire the charge and record the temperature in one minute intervals until the maximum is reached
- e) Open the calorimeter, remove the bomb, release the residual pressure and open the bomb. Rinse the inside of the bomb with a stream of water and collect all washings in a clean beaker. Titrate the contents of the beaker with standard alkali. This is necessary for correction on account of acid formed on oxidation of nitrogen
- f) Remove the unburned pieces of wire and measure (approximately) the combined length in mm. This is in order to estimate the correction for the burned fuse

Knowing the so-called "water equivalent" factor of the calorimeter, it is possible to determine the heat of combustion at *constant volume* with an accuracy better than 1%

Note: The water equivalent factor includes the heat capacity of the ensemble which includes: the calorimeter itself, water bucket with water in it, supports of the bucket, bomb, thermometer and stirring device. These values can be calculated theoretically, but much more accurate results are obtained by combustion of a sample of standard material (such as benzoic acid, supplied by the US Bureau of Standards), the heat of combustion of which has been previously accurately determined. The water equivalent values of the calorimeters and bombs supplied by the Parr Instrument Co are determined by them at the factory

Because knowledge of the heats of combustion of organic compounds provides important information for making physico-chemical calculations (such as heats of formation), attempts have been made to find empirical rules for calculating the heats of combustion of compounds which have not been determined with accuracy in calorimeters

Sventoslavsky (Ref 2a) developed in 1908 a method of calculation of heats of combustion which later proved to be in agreement with the method developed by Kharash (Ref 4). Kassatkin & Planovsky gave a good description of Sventoslavsky's method (Ref 7, p 31). Later, Thornton (Ref 2b) has shown that the molar heat of combustion at constant volume of any saturated hydrocarbon at room temperature is approximately 52.7 kcal for each atomic weight of oxygen required to burn it. For example, methane, which burns according to the equation:

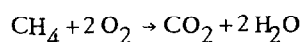

requires 4 oxygens per mole of CH_4 and this gives $Q_C = 4 \times 52.7 = 210.8$ kcal/mole. The exptl value for the heat of combustion of methane is 212 kcal, which means that the two values are in good agreement

Kharash (Ref 4) has developed a comprehensive method for estimating the heat of combustion of an organic compound from a knowledge of its molecular structure and the total number of electrons shifted in the formation of CO_2 molecules. He assumed

that whenever an organic substance is burned in oxygen, the heat generated is due to the interdisplacement of the electrons between C and O atoms. It is further assumed that the amount of these energy interchanges in the form of heat is equal to 26.05 kcal per electron per mole, if the initial and final stages correspond to the arrangement the electron occupies around the carbon nucleus in methane and CO_2 respectively. It is easy to perceive that since the factor 26.05 corresponds only to certain definite initial and final stages of the electron, whenever a substance is burned which contains some electrons displaced from that position, the calculated value should either be smaller or larger than the experimental value, depending upon whether the electrons are nearer or farther from the carbon nucleus than those of CH_4

The general expression for the heat of combustion of organic compounds may be given as follows:

$$Q_C = [26.05 \times N + c] \text{ kcal/mole}$$

where (N) is the number of electrons interdisplaced between C and O atoms and (c) correction factor, depending on the type of compound. These factors are given in Ref 4 and some additional data may be found in Ref 7. The value given earlier by Sventoslavsky was 26.12 kcal/mole, which is considered as being very close to that of Kharash (26.05)

As an example, let us calculate the heat of combustion of methane (which requires no correction) by the Kharash method:

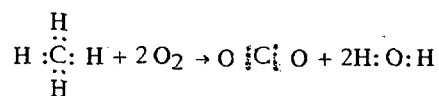

In this equation all 8 electrons of CH_4 are shifted for the formation of CO_2 and H_2O and (N) is 8, which gives $Q_C = 26.05 \times 8 = 208.4$ kcal/mole. The same value calculated by the formula of Sventoslavsky gives: $26.125 \times 8 = 209.0$ kcal/mole

The experimental value for methane given in Ref 8, p 264 is 212 kcal/mole, while in Lange's Handbook it is 210.8

A more complicated example is the combustion of *o*-toluic acid:

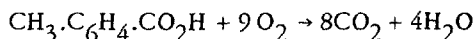

According to this equation, electrons of 7 (out of 8) carbons are shifted ($7 \times 4 = 28$), as well as all electrons of hydrogen ($8 \times 1 = 8$), which gives $N = 36$. As *o*-toluic acid belongs to the aromatic series, the correction from Kharash's tables is equal to -3.5×2 . This will give:

$$Q_C = 26.05 \times 36 - (3.5 \times 2) = 930.8 \text{ kcal/mole}$$

This is in fair agreement with an experimental value of 928.9 given in Lange's Handbook

Dunkle (Ref 40, p 251) stated that Lotherop & Handrick (Ref 30) (See also Encycl, Vol 1, p A513, under Auxoplose and Plosephore) suggested deriving [by method of Kharash (Ref 4) and Schmidt (Ref 8)] heat of combustion values from structural features of the molecules. Then heat of expln may be derived and the expected performance estimated from the curves. They cautioned, however, that the curves are idealized and that values for individual compds may depart significantly in either direction. Handrick in a later article (Ref 37, p 1373), making comparisons at the same oxygen balance, noted that the energy available thru combstn can be increased by replacing hydrogen and a single bond with a double or triple bond. Even more energy is introduced by substituting an azide group or a peroxide group for hydrogen. The effect of lengthening a chain of nitrogen atoms is to increase the energy content. Thus azo and hydrazine give less energy than triazine or tetrazine, which in turn give less than pentazine

In this article Handrick listed numerous refs to proposals offered from time to time for calcg heats of combstn by methods of summation of bond energies, methods based on empirical formulas, and methods of summation of group energies. He offered a new method of the latter type based on the experimentally found straight-line relation of the molar heats of combstn of any organic homologous series to the number of oxygen

atoms lacking in the molecule for complete combstn to CO_2 , H_2O , N_2 , SO_2 , HX (X is halogen). This number he called the *molar oxygen balance* (X):

$$X = 2(c + s) + \frac{1}{2}(h - x) - o$$

where c, s, h, x & o are numbers of atoms of C, S, H, X (halogen) and O per molecule of compound. Heats of combstn in any homologous series when plotted against X give a straight line and the lines for different series have their own values of intercept and slope. These values are summation of intercept coefficients (a'_i) and slope coefficients (b'_i) for the (i) functional groups present, so that the heat of combstn at const pressure can be written:

$$Q_C^P = \sum a'_i + X \sum b'_i$$

An extensive table gives values of intercept and slope coefficients for each of a large number of functional types. Another shows how the summations of the various slope coefficients and intercept coefficients are made for each of a number of illustrative cases (Ref 40, p 252)

Young et al (Ref 38, p 1375) also plotted the heat of combstn vs the number of oxygen atoms required for complete oxidation to CO_2 (gas), H_2O (liq) and N_2 (gas), but unlike Handrick, they do not deduct the number of oxygen atoms bound to N in $-\text{NO}_2$, for they do not consider such oxygen as "loosely held and available for subsequent combustion". They found that while the lines for different homologous series may have different intercepts, the slopes of the lines are remarkably close to equality. Many have the value 52.48. The intercepts are zero for the benzenes and for the acid amides, but the slopes differ slightly, being 52.4 & 51.8 respectively. The line having intercept zero and slope 50.3 fits all types of nitro compds without particular constants

for the particular compd (Ref 38, p 1378)

In Dunkle's Syllabus (Ref 40, p 252), it is stated that heats of combstn can be calcd from heats of atomization (Q_A). For example, for a compd of C, H, N & O

$Q_A = Q_F + 170.39c + 52.089h + 113.0n + 59.01o$
and since $Q_C = -Q_F + 94.05c + 34.16h$, it follows that:

$$Q_C = -Q_A + 264.44c + 86.25h + 113.0n + 59.01o$$

From the heat of combustion (Q_C) the heat of expln at const volume (Q_E^v) can be obt'd by the approximation:

$$Q_E^v = Q_C - 135 [2(c+s) + 0.5(h-x) - o]$$

All the heats are kcal per mole

A more accurate value can be obt'd from the equation given by Taylor (Ref 34b, p 43)

$$Q_E^v = \sum_i n_i \int_{T_0}^{T_{v_i}} c_{v_i} dT + \sum_i n_i L_i \text{ cal/g}$$

where (n_i) is the number of moles from each gram of expl of the "th expl product; (c_{v_i}) is heat capacity at const volume and (L_i) is latent heat per mole; (T_v) is temperature of expln and (T_0) is room temp. The summation signs indicate that the terms must be evaluated and summed up for all of the expln products

An average or "effective" molar specific heat may be defined by the relationship:

$$\bar{c}_v = (L + \int_{T_0}^{T_v} c_v dT) / (T_v - T_0),$$

where (L) is the latent heat of vaporization at 1 atm pressure

The final equation given in Ref 40, p 253 is:

$$Q_E^v = n \bar{c}_v (T_v - T_0),$$

where (n) is the total number of moles of all products per gram of explosive

Accurate determination of T_v often involves a series of tedious calculations of the equilibrium composition of the explosion products at several temperatures. Von Stein & Alster of PicArns presented a new method which offers a simple general treatment for arriving at equilibrium compositions for C-H-N-O explosives of any oxygen balance. The novel feature of this method which is described in PATR 2501 (Ref 40a) is that the temperature of explosion can be determined directly from the known heat of

combustion of the explosive rather than from the heat of explosion. The procedure may be considered the "addition of a negative quantity of oxygen" with corresponding absorption of heat (Ref 40, p 244)

A method of calculation of heats of combustion used in Russia in conjunction with determination of permissibility of coal-mining explosives is described by Bandurin & Rukin (Ref 42a) and also in this Encycl, Vol 3, pp C447 to C450

Heats of combustion of explosives deficient in oxygen (See Vol 1 of Encycl, p A515, under "Available Oxygen") are always higher than either their heats of explosion or of detonation. For expls with positive oxygen balance to CO_2 , like NG, there should not be any difference between these values

Values for heats of combustion may be found in the same sources as indicated under "Heat of Formation". Some selected values for explosives are given in the Table which is at the end of "Heat of Explosion and Heat of Detonation"

Note: For exothermic but non-explosive reactions such as those of thermites and some pyrotechnic mixtures, it is customary to refer to a general term, *heat of reaction*. In such cases this is usually determined for convenience in a *constant-volume bomb* at an initial pressure of 1 atm of inert gas. The enthalpy change is then calculated (as will be later explained) by correction to *constant pressure* (Ref 40, p 248)

Refs: Same as listed after "Heat of Explosion and Heat of Detonation"

Heat of Deflagration. If an explosive, serving as a propellant (such as BkPdr or a smokeless propellant) is initiated by an electric blasting cap, in a calorimetric bomb (similar to that used for determination of heat of combustion) under confinement, but without addition of oxygen, the substance usually behaves as if it were fired in a gun barrel. This is known as "deflagration" (See Vol 3 of Encycl, p D38-R) and the energy liberated is called the *heat of deflagration*. Some other explosives (such as blasting explosives, or even high explo-

sives) might deflagrate instead of exploding when fired in the same manner as above.

In many cases it is difficult to distinguish between deflagration and explosion

Refs: Same as listed after "Heat of Explosion and Heat of Detonation"

Heat of Explosion (Q_E) (Explosionswärme in Ger), and *Heat of Detonation* (Q_D) (Detonationswärme in Ger)

Heat of Explosion is defined by Dunkle (Ref 40, p 248) as the "heat liberated at calorimeter temperature when an explosive explodes at constant volume. (Such explosion may be a detonation). Ideally this volume is the same as that occupied by the original sample of explosive, so that the heat of expln is of the same magnitude as the internal energy change during the process but of opposite sign. This may be considered the quantity of heat which would be lost by the products in cooling from the isochoric adiabatic explosion temperature (T_V) to the calorimeter temperature (T_O)"

Note: Calorimeter temp (T_O) is usually taken as 298° K and heats measured at that temp can be used thruout the test, because it does not matter if some time during the reaction the reacting mixture is heated temporarily to a higher temp, for the energy evolved is dependent only on the initial and final states (Hess' Law) and in case the initial and final temps are identical it amounts to the same in the end as if the temp had remained constant during the reaction (Ref 36, p 10)

Dunkle also stated on pp 244-45 of Ref 40 that "Ideally, the explosion process is considered to take place within the same volume as that occupied by the original sample, so that the heat of explosion is equal in magnitude to the internal energy change (ΔE) but of opposite sign. This ideal is approached closely enough by the usual procedure of using a constant-volume bomb of somewhat larger volume and an initial pressure of 25 atm of inert gas. The heat which would be evolved by the same process at constant pressure can be calculated from the thermodynamic relationship:

$$\Delta H = \Delta E + \Delta(PV),$$

where $\Delta(PV)$ is the sum of the pressure-volume products of the reaction products minus the sum of the pressure-volume products of the reactants. Since the value of PV is much smaller in a condensed phase than in a gas, there will usually be little difference between ΔE and ΔH if all products and reactants are liquids and/or solids. For practical purposes $\Delta(PV)$ equals $\Delta n_g RT$, which is the increase in the number of moles of gas during a reaction of explosion, so that:

$$\Delta H = \Delta E + RT\Delta n_g$$

An exothermic reaction, in which ΔH and ΔE are both negative, yields more heat at constant volume than at constant pressure if Δn_g is positive

Heat of Detonation is defined by Dunkle (Ref 40, p 248) as the "heat liberated at calorimeter temperature when an explosive detonates at constant volume and with no change in the product composition from that which was obtained at C-J point. Heat of detonation can be calculated from heat of explosion, or a closer experimental approach can be attempted by detonating the sample at high density and under strong confinement"

In addition to this definition, Dunkle stated in Ref 40, p 245 that "the heat of detonation is the difference given by subtracting the heat of formation of the explosive, from the collective heat of formation of the mixture of products as it exists at the C-J point, where they are at about 5000° K and still at about 10^5 atm. Both heats of formation are referred to the same standard temperature, but the product composition is taken as corresponding to equilibrium at the C-J Point"

Note: The C-J temperature (T_1) is much higher than temperature of detonation (T_V), as explained in Ref 40, p 199

"The heat of detonation therefore is, like the heat of explosion, a function of the chemical energy of the explosive. In fact, the two heats differ only by the thermal effect, at standard temperature, of the shift in composition of the product mixture between (T_1) and (T_V). This depends on the

elementary balance, particularly that of oxygen. For a moderately oxygen-deficient explosive, in which the products are those of the water gas equilibrium and nitrogen, such heat effect should be small due mostly to the shift in that equilibrium. This actually has at 33°C, to H₂O (liq), a heat of reaction of zero at constant volume"

For expls so deficient in oxygen that the "soot" reactions $[2\text{CO} \rightleftharpoons \text{C}(\text{graphite}) + \text{CO}_2$ and $\text{H}_2 + \text{CO} \rightleftharpoons \text{C}(\text{graphite}) + \text{H}_2\text{O}(\text{gas})]$ (Ref 40, p 235) become important, there may be considerable difference betw the two heats and this can be calcd approximately. Just as the product composition found in the bomb can be corrected for the shift from the equilibrium values for (T_v), it can be corrected for the larger shift from (T_1). Alternatively, a closer experimental approach to the heat of detonation can be attempted by preventing post detonation changes in the product compn so far as possible. Such an attempt was made in 1923, as described by Robertson & Garner (Ref 3a), by detonating the sample at high density and under strong confinement. This kept pressures higher and allowed faster cooling; also the products worked against resistance by shattering a steel capsule within the bomb while still at high pressure. This too speeded cooling in hopes of freezing the chemical equilibria at "high pressure" values. Here there are more C, CO₂ and H₂O but less CO and H₂ than at "low pressures". In determining heat of explosion, on the other hand, no such attempt was made and pressure dropped quickly in the bomb, but temp stayed longer because the products made only a free expansion and no work. They thus had time to react, and approach their "low pressure" composition before the equilibria freezes. Under these conditions, therefore, temperature rather than pressure dominates (Ref 40, pp 244-45)

Note 1: It seems that the values reported in the literature are called "heats of explosion" and only seldom "heats of detonation". Quite different values are reported sometimes by various investigators for the same explosive and it is hard to say whether they mean

explosion or detonation. We think that for practical purposes it is of no importance. In the table given at the end of this Section, we list mostly the average values, since nobody knows which of the values reported by various investigators are right and which are wrong

Note 2: It seems that the term *heat of explosion* would be appropriate to apply when a low explosive (such as a blasting explosive) or a high-explosive of not very high brisance (such as TNT) is exploded by means of an electric cap in a large volume calorimetric bomb, under confinement, but without addition of oxygen. The term *heat of detonation* can be applied when a high-explosive (such as Tetryl, PA, PETN or RDX) is detonated by means of an electric cap in a calorimetric bomb of small diameter with very thick wall, bottom and top, under very strong confinement, but without addition of oxygen

Note 3: In the opinion of some investigators (See below), the same high explosive (such as Tetryl) can either explode or detonate and the heat of detonation is higher than the heat of explosion

Since heats of expln and of deton are measured at constant volume, no work is done against the atmosphere. The heat measured, in both cases, is the difference between the internal energies of the original expl and its products at calorimetric temp (ca 298°K). Rossini (Ref 34b, p 77) pointed out that the change in internal energy for the isothermal bomb process, of combstn for instance, is not quite the same as for the idealized combstn reaction. This is defined as the reaction, isothermally at T_0 , of a given quantity of substance in the standard state, to give pure CO₂, pure H₂O and other substances present in appropriate chemical form, all in their standard states. What is actually found in the bomb is a gaseous mixture saturated with water vapor at appreciable pressure, and an aqueous soln saturated with CO₂, N₂, etc at this pressure. The calculated heat effects of the change from one system to the other are called the "Washburn correc-

tions" (Ref 34b, p 75), and are necessary when accurate heats of reaction, formation, combustion, etc are to be compared with published values. These corrections are not usually made for heats of explosion or detonation, since a knowledge of the internal energy change in the isothermal bomb process is sufficient for most applications (Ref 40, pp 248-49)

A given explosive may be considered to have more than one heat of expln or deton. For example, Sutton (Ref 15a, as quoted in Ref 40, p 249) showed, in 1938, how the quantity of heat evolved in a detonation bomb is affected by confinement, pelleting density, charge length and strength of initiation. The curves presented in Ref 40, p 249, show that as higher densities of pelleting are used, the equilibrium in the "soot" reactions (See above) shifts toward the right, with deposition of carbon and greater evolution of heat. On varying the densities of Tetryl pellets from 0.9 to 1.7, Sutton obtained three values for heats of deton: 930 cal/g at d 0.9, 1065 at d 1.3 and 1160 at d 1.7. Dunkle calls the value 1160 obtd at high density and strong confinement, even with weak initiation, the heat of detonation, while the value of 930 obtd if either density or confinement is decreased, even with strong initiation, heat of explosion. He does not say how he calls the value of 1065 cal/g. Sutton, on the other hand, called all of his values heats of detonation. He suggested that there are three different modes of detonation involving chemical reactions which yield 0, 1 and 1.5 gram atoms of carbon for each mole of Tetryl detonated

While there is no general agreement on the definition of heat of detonation, referring the product composition to that of "C-J Point" gives the term a definite meaning. By detonating the sample at high density and under heavy confinement, one can measure the internal energy change for a process similar to that occurring under the conditions of actual use of the explosive. The heat of detonation may be considered a sort of "limiting" value which might be

approached as the efficiency of utilization of the energy evolved in the detonation of the explosive increases. Heat and rate of detonation, taken together, serve as a useful means of comparing and evaluating the practical usefulness of expls for certain applications (Ref 40, pp 249-50)

As was already mentioned, *experimental determinations* of heat of explosion and of heat of detonation are conducted in steel or special alloy cylindrical vessels of strong construction, known as "constant volume explosion bomb calorimeters" and as "detonation calorimeters". To the brief description of such calorimeters (bombs), which is given in Vol 2 of Encycl, p C11-R, the following may be added:

The earliest bombs used for determination of heats of explosion were those of Berthelot and of Sarrau but they were not sufficiently strong for all explosives. Noble and Abel constructed a very strong bomb which could take as much as 500 g of BlkPdr. Later they constructed smaller bombs of 32.5 and 118.8 cc capacities with very thick walls. Burlot and Malsallez also constructed a very thick bomb with a capacity of 25 cc. Bichel and Mettegang, not desiring to make their bomb too thick and heavy, constructed a bomb with walls only 13 mm thick but with a capacity of 30000 cc. The Centralstelle Neubabelsberg, Germany, constructed a strong nickel-steel bomb with a capacity of about 45 cc which could take a charge up to 20 g. The bomb used by the US Bureau of Mines had a 26000 cc capacity. It was bottle-shaped, 73 cm high and 25.6 cm inside diameter of the cylindrical section. Its walls were 11.1 mm in thickness and the bomb weighed 71.3 kg and took a charge of 100 g of explosive. The bombs used at Picatinny Arsenal after WWII for determination of heats of detonation had capacity of 13 cc and were designed and constructed at Picatinny Arsenal. The bombs with heavy body, constructed after WWII by the Parr Instrument Co of Moline, Ill for the determination of heats of combustion, were found to be suitable for detn of heats of expln

of some expls

The procedure for the detn of the heats of expln and deton is essentially the same as for detn of heats of combstn, except that no oxygen is pumped into bomb and expls are initiated by an electric cap and not ignited by an incandescent wire as in the case of combstn

It is often desired to determine the volume of gas formed on explosion as well as its composition. The volume of gas may be approximately estimated if the pressure inside the bomb is measured after the gas assumes room temperature (T_0). The analysis of the products of explosion is done by regular "gas analysis" procedures. If the products of explosion are known, the heat liberated can be calculated from their known heats of formation and those of the original constituents of the explosive - the sum of the former minus the sum of the latter is the heat of explosion

The composition of gaseous products of explosion (or detonation) as determined by analysis is not identical with that of products formed immediately after expln (or deton), because some chemical interaction takes place during cooling. This means that the heat actually measured in any calorimeter is that evolved after the products have come to equilibrium at calorimeter temperature. Some improvement in calculation can be made by correction for the shifts in proportions of ingredients during cooling. Attempts were also made to prevent interaction in calorimeters during cooling (as described above), but it did not solve the problem 100%

As was mentioned already, the explosion process can be considered as taking place within the same volume as that occupied by the original sample, so that the "heat of explosion" is equal in magnitude but opposite in sign to the internal energy change (ΔE). This ideal is approached closely enough by the usual procedure of using a constant-volume bomb of somewhat larger internal volume and an initial pressure of 25 atm of inert gas. The enthalpy change (ΔH), the negative of the heat which would be evolved by the same process at

any constant pressure, can be calculated from the volume change at that pressure. For Nitroglycerin (NG), as an example, it would be necessary to recalculate the value of heat of explosion determined in the bomb at constant volume (Q_E^V) to the constant pressure basis (Q_E^P)

Let us assume that the value (Q_E^V) obtained experimentally for NG is:

$$Q_E^V = 349.2 \text{ kcal/mole} = 349.2 \times \frac{1000}{227.09} = 1537.7 \text{ kcal/kg or cal/g,}$$

where 227.09 is molecular weight of NG

Accdg to Hayes (Ref 15, p 54):

$$Q_E^V = Q_E^P + 0.572n \quad \text{or} \quad Q_E^P = Q_E^V - 0.572n$$

where (n) is the number of molecular volumes of gas resulting from the explosion of 1 gram-mole of explosive. As each mole of NG liberates 7.25 molecular volumes of gas:

$$Q_E^P = 349.2 - 0.572 \times 7.25 = 345.1 \text{ kcal/mole} = 345.1 \times \frac{1000}{227.09} = 1519.7 \text{ kcal/kg or cal/g}$$

If a calorimetric bomb is not available and if the products of explosion are not determined by analysis, the heats of explosion can be approximately estimated from the equation of explosion

Taking again, as an example, the explosion of NG (which happens to contain within its molecule sufficient oxygen for complete oxidation):

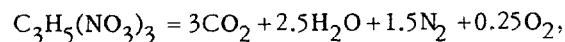

we have from tables given by Schmidt (Ref 8) or in handbooks, the heats of formation of NG 82.7 kcal/mole, of CO_2 94.5 and of H_2O (gas) 57.7. The nitrogen and oxygen have not combined in the reaction and therefore do not give off heat

Therefore, the sum of heats of formation of the products of explosion, minus the heat of formation of NG is equal to:

$$(3 \times 94.5 + 2.5 \times 57.7 + 0 + 0) - 82.7 = 345.1 \text{ kcal/mole,}$$

where 345.1 is the heat of explosion in kcal per mole. This heat is calculated

assuming that the products of combustion were reduced to atmospheric pressure and to a temperature of 15°C. It is therefore known as heat of explosion at constant pressure (Q_E^P). The heat of formation was taken for water in the gaseous state because at the high temperature of explosion it is gaseous (Ref 8)

The heat of formation of NG can be calculated if heats of formation of glycerin and nitric acid are known. They are given by Pérez Ara (Ref 23, p 36) as 159.8 and 42.4 and for water (liquid) 68.4 kcal/mole

As the reaction proceeds accordg to the equation:

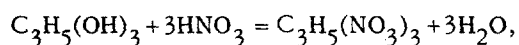

the heat of formation (Q_F) of NG will be:

$$Q_F = (3 \times 159.8 + 3 \times 42.4) - 3 \times 68.4 = 81.8 \text{ kcal/mole}$$

This value checks within one kcal with the value given by Schmidt (Ref 8)

The above listed value for heat of expln of NG

$$Q_E^V = 1537.7 \text{ cal/g}$$

assumes that water is in liquid form (WL)

The corresponding value given by Taylor (Ref 34b, p 62) is 1616 cal/g. If water is assumed to be in gaseous state (WG), Taylor gives the value for NG

$$Q_E^V(WG) = 1503 \text{ cal/g}$$

The last value was obt'd from the following equation given on p 55 of Ref 34b:

$$Q_E^V(WG) = Q_E^V(WL) - 10.23n_{H_2O}$$

where (n_{H_2O}) is the number of moles of water formed as indicated in the equation for expln of NG:

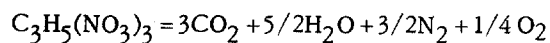

Taylor also gives on p 60 the formula for calculating the heat of explosion if the heat of combustion is known:

$$Q_E = Q_C - 67.33n_{CO} - 67.70n_{H_2},$$

where (n_{CO}) and (n_{H_2}) are the numbers of moles of carbon monoxide and hydrogen re-

spectively

The explosion temperature (T_V) is then calcd as explained by Taylor with the aid of Tables 6, 8, 9 & 12 given in his book

As accurate determination of (T_V) often involves a series of tedious calculations of the equilibrium composition of the expln products at several temperatures, Von Stein & Alster of PicArSn (Ref 40a) presented a new method which offers a simple general treatment for arriving at equilibrium compositions for C-H-N-O expls of any oxygen balance

Values for heats of combustion, explosion and formation for some expls of military interest are given in Tables A & B compiled from various sources (See ppD380 & D381)

Refs: 1) M. Berthelot & C. Matignon, CR **113**, 246 (1891) (Chaleur de combustion) 2) M. Berthelot, "Thermochimie", Gauthier-Villars, Paris (1897) 2a) V. Sventoslavsky, JRussPhysico-ChemicalSoc **9**, 1257 & 1602 (1908) (A method for calculating heats of combustion) 2b) W.M. Thornton, PhilMag **33**, 196 (1917) (A method of calculation) 3) W. Garner & C. Abernethy, PrRoySoc (London) **99A**, 213-35 (1921) (Heats of combstn) 3a) R. Robertson & W. Garner, PrRoySoc(London), **103A**, 539-55 (1923) (Calorimetry of high expls) 4) M.S. Kharash, JResearchNatIBurStandards **2**, 352 (1929) (Heats of combustion) (246 refs) 5) W.H. Rinkenbach, JACS **52**, 115-20 (1930) (Heats of combstn of aromatic nitrocompds) 6) C.E. Munroe & J.E. Tiffany, "Physical Testing of Explosives", USBurMinesBull **346** (1931), 99-104 (Heats of expln as detd in calorimeter) 6) W. Ostwald, R. Luther & C. Drucker, "Physikalische Messungen", AkadVerlagsgesellschaft, Leipzig (1931) 7) A.G. Kassatkin & A.N. Planovskii, "Processes and Apparatus of Organic Synthesis Industry", Moscow (1931) 7a) Vennin, Burlot & Lécorché (1932), p 34 (Calcul des chaleurs de combustion ou d'explosion); 35 (Determination des chaleurs de formation des explosifs); 60-2 (Bombes calorimetriques de Berthelot-Vieille, Moureau, Landrieu-Malsallez, Mahler and Burlot-Malsallez); 62-6 (Calorimetre de la Commission des

Table A
Heats of Combustion, Explosion and Formation For
Some Explosives of Military Interest

| Explosive | Heats, in kcal/kg, of | | |
|---|--------------------------------|-----------|-----------|
| | Combustion | Explosion | Formation |
| 80/20 Amatol (AN 80 & TNT 20%) | 1002 | 490 | - |
| 50/50 Amatol (AN 50 & TNT 50%) | 1658 | 633 | - |
| Ammonium Nitrate (NH ₄ NO ₃) | 346 | 346 | - |
| Ammonium Perchlorate (NH ₄ ClO ₄) | - | - | 665 |
| Baronal (Ba nitrate 50, TNT 35 & Al 15%) | 2099 | 1135 | 410 |
| Black Powder (K nitrate 74.0, S 10.4 & charcoal 15.6%) | - | 684 | - |
| BTNT (1,2,4-Butanetriol Trinitrate) (Liquid) | 2168 | 1457 | - |
| Cellulose Nitrates | See NC(Nitrocellulose) | | |
| Composition A-3 (RDX 91 & wax 9%) | 7210 | - | - |
| Composition B (RDX 60 & TNT 40% with added wax 1 part) | 2790 | 1240 | - |
| Compositions C, C-2, C-3 & C-4 | No information | | |
| Copper Chlorotetrazole | - | 432 | - |
| Cyanuric Triazide | - | - | 1100 |
| Cyclonite (RDX) (Cyclotrimethylenetrinitramine) | 2285 | 1280 | -96 |
| 75/25-Cyclotol (RDX 75 & TNT 25%) | 2625 | 1225 | - |
| 70/30-Cyclotol | 2685 | 1213 | - |
| 65/35-Cyclotol | 2775 | 1205 | - |
| 60/40-Cyclotol | 2820 | 1195 | - |
| DADNPh (Diazodinitrophenol) | 3243 | 820 | - |
| DBX (AN 21, RDX 21, TNT 40 & Al 18%) | - | 1700 | - |
| DEGDN (Diethyleneglycol Dinitrate) | 2792 | 841 | 526 |
| DNT (Dinitrotoluene) | 1545 | - | - |
| DPEHN (Dipentaerythritol Hexanitrate) | 2260 | - | - |
| EDNA | See Haleite | | |
| Explosive D (Ammonium Picrate) | 2890 | 800 | 395 |
| GcDN (Glycol Dinitrate) or NGc (Nitroglycol) | 1764 | - | 366 |
| GLTN (Glycerolmonolactate Trinitrate) | 2407 | - | - |
| GTN (Glycerol Trinitrate) | See NG (Nitroglycerine) | | |
| Haleite or EDNA (Ethylenedinitramine) | 2477 | 1276 | 134 |
| beta-HMX (Cyclotetramethylenetetranitramine) | 2362 | 1365 | -60.5 |
| HNMnt (Hexanitromannitol) | See MHN (Mannitol Hexanitrate) | | |
| HNO (2,4,6,2',4',6'-Hexanitrooxanilide) | No information | | |
| KDNBF (Potassium Dinitrobenzofuroxan) | 2209 | 725 | - |
| LA (Lead Azide) | 630 | 367 | -346 |

Substances Explosives) 7b) Stettbacher (1933), pp 78-83 [Explosions - (und Verbrennungs)-wärme]; 83-5 (Sprengstoffcalorimeterbombe) 8) A. Schmidt, SS 29, 259-65 & 296-301 (1934) (Tables giving values of heats of combstn, expln and formation of various expls) 8a) Ibid, 30, 364-69 (1935) (Detonation of explosives)

9) F.D. Rossini, JResNatIBurStandards 12, 735 (1934) (Heats of combstn) 10) H.M. Huffman & F.L. Ellis, JACS 57, 41 (1935) (Heats of combstn) 10a) Pepin Lehalleur (1935), p 43 (Calcul de chaleur de combustion); 44-5 (Ensemble calorimetrique Landrieu-Malsallez et bomb Burlot-Malsallez); 47-9 (Tables des chaleurs de formation)

Table B

| Explosive | Heats, in kcal/kg, of | | |
|---|----------------------------|-----------|-----------|
| | Combustion | Explosion | Formation |
| LDNR (Lead 2,4-Dinitroresorcinate) | - | 230 | - |
| LSt (Lead Styphnate) | 1251 | 457 | -92 |
| LVD (Low Velocity Dynamite) | - | 625 | - |
| (Composition given in Ref 41a, p 119) | | | |
| MF (Mercuric Fulminate) | 938 | 427 | -226 |
| MHN (Mannitol Hexanitrate) or HNMnt | 1520 | 1458 | 349 |
| Minol-2 (TNT 40, AN 40 & Al 20%) | 3160 | 1620 | - |
| MTN (Metriol Trinitrate) | 2642 | - | - |
| MVD (Medium Velocity Dynamite) | - | 935 | - |
| (Composition is given in Ref 41a, p 123) | | | |
| NC (Nitrocellulose) (12.6% N) | 2409 | 855 | 617 |
| NC (13.45% N) | 2313 | 965 | 561 |
| NC (14.14% N) | 2228 | 1058 | 513 |
| | Heat of detonation 1486 | | |
| NG | 1616 | 1600 | 400 |
| NGc (Nitroglycol) or EGDN (Ethylene glycol Dinitrate) | See GcDN (Glycoldinitrate) | | |
| NGu (Nitroguanidine) | 1995 | 721 | 227 |
| PA (Picric Acid) | 2672 | 1000 | 248 |
| 50/50-Pentolite (PETN 50 & TNT 50%) | - | 1220 | - |
| PETN (Pentaerythritol Tetranitrate) | 1960 | 1385 | 383 |
| PLX (Liquid) (NMe 95 & ethylenediamine 5%) | 2830 | - | -348 |
| Potassium Dinitrobenzofuroxan | See KDNBF | | |
| PVN (Polyvinyl Nitrate) | 2690 | 900 | - |
| SA (Silver Azide) | - | 452 | 67.8 |
| Tetracene (Guanylnitrosaminoguanilyltetrazene) | - | 658 | - |
| TEGDN (Triethyleneglycol Dinitrate) (Liquid) | 3428 | 357 | - |
| Tetryl (2,4,6-Trinitrophenylmethyl nitramine) | 2925 | 1100 | -14 |
| TNT (2,4,6-Trinitrotoluene) | 3620 | 1080 | 78.5 |
| TNTAzB (Trinitrotriazidobenzene) | 2554 | - | - |
| Torpex (RDX 42, TNT 40 & Al 18%) | 3740 | 1800 | - |
| 80/20-Tritonal (TNT 80 & Al 20%) | 4480 | 1770 | - |

11) F.R. Bichowsky & F.D. Rossini, "The Thermochemistry of Chemical Substances", Reinhold, NY (1936) 12) F.D. Rossini, ChemRevs **18**, 233 (1936) (Heats of combstn) 13) P. de Paw, SS **32**, 10-12, 36-7 & 60-3 (1937); CA **31**, 3696 (1937) (Formula for accurate and rapid calcn of heat of combstn) 14) M. Tonegutti, SS **32**, 93-7 (1937) & CA **31**, 6465 (1937) (Heats of expln for PETN, RDX & TNT) 15) Hayes (1938), 51 & 55 (Heats of expln); 39 (Heats of formation) 15a) T.C. Sutton, TrFaradSoc **34**, 992-94 (1938) (Energy measurements indicating three characteristic modes of detonation

of Tetryl) 16) W. Richardson & G.S. Parks, JACS **61**, 3543 (1939) (Heats of combstn) 17) R.R. Wenner, "Thermochemical Calculations", McGraw-Hill, NY (1941), pp 41-6, 48-9, 51-6, 74 & 109-11 (Heats of formation); 42, 43 & 46-9 (Heats of combustion) (No heats of explosion or detonation are given) 18) G.B. Kistiakowsky, OSRD Rept **2937** (1941) (Determination of heats of combustion of expls) 19) E.J. Prosen & F.D. Rossini, JResNatlBurStandards **27**, 289 (1941) (Calorimetric bombs of Prosen & Rossini) 20) G.B. Kistiakowsky, OSRD Rept **702** (1942) (Heats of combstn and of

- expln) 21) W.H. Rinckenbach, *PATR* **1265** (1943) (Heats of combstn) 22) C.R. Robinson, "Thermodynamics of Firearms", McGraw-Hill, NY (1943), p 7 (Heat of combstn); 41 (Heat of expln); 46 (Heat of formation) 22a) Vivas, Feigenspan & Ladreda, Vol 4 (1944), p 13-18 (Cantidad de calor desarrollado); 79-80 (Calorimetro para explosivos); 81 (Bomba Burloz-Malsallez); 82-4 (Calorimetro Landriue-Malsallez) 22b) A.H. Blatt, OSRD **2014** (1944) (Compilation of Data on Organic Explosives) 23) Pérez Ara (1945), pp 35-6 & 47-8 (Calor de formacion); 36-40 (Calor de combustion); 61-70 (Calor de explosion y bombas calorimetricas de Bichel-Mettegang, Landriue-Malsallez y Burlot-Malsallez) 24) J. Corner, Pr-RoySoc(London) **58**, 737-58 (1946) (Heats of combstn) 24a) W.A. Roth, "Thermochemie", W.deGruyter & Co, Berlin (1947), 90-92 (Heats of formation); 70-92 (Heats of combstn) 25) J. Taylor et al, *JPhys & ColloidChem* **51**, 580-92 & 593-611 (1947) (Thermochemistry of expls & proplnts) 26) A.D. Little Inc, "Correlation of Thermal Quantities with Explosive Properties", Contract No W-19-020-ORD-6436, Rept Apr 2, 1947) 26a) Parr Manual **No 120**, Parr Instrument Co, Moline, Ill (1948) 26b) Stettbacher (1948), p 8-10 (Detonationswärme und Verbrennungswärme) 27) Kirk & Othmer **2** (1948), 793-808 (Calorimetry); *Ibid* **13** (1954), 941-52 (Thermochemistry) 28) A. Weissberger, Edit, "Physical Methods of Organic Chemistry", Interscience, NY, Vol 1, Pt 1 (1949), 783 & 828 29) L. Médard & M. Thomas, *MP* **31**, 173-96 (1949) (Heats of combstn at const volume of 18 nitrocompds and org nitrates) 30) W.C. Lothrop & G.R. Handrick, *ChemRevs* **44**, 419-45 (1949) (Relationship betw performance and constitution of pure org compds) 31) R.L. McKisson & L.A. Bromley, "A New High-Temperature Calorimeter", USAEC Rept **UCRL-688** (1950) 32) F.D. Rossini, "Chemical Thermodynamics", Wiley, NY (1950) 33) F.R. Bichowsky & F.D. Rossini, "Thermochemistry of Chemical Substances", Reinhold, NY (1951) 33a) Stettbacher, *Pólvoras* (1952), p 10-12 (Calor de detonación) 34) F.D. Rossini et al, "Selected Values of Chemical Thermodynamic Properties", USGovtPrintingOff, Washington, DC (1952) 34a) Belgrano (1952), p4 (Calore di esplosione); 8-9 (Calore di formazione) 34b) Taylor (1952), pp 40-64 (Thermochemistry of expls) 34c) R.D. Rossini, "Experimental Thermochemistry", Interscience, NY (1955), pp 75-77 35) L. Médard & M. Thomas, *MP* **36**, 97-127 (1954) & **37**, 129-38 (1955) (Heats of combstn of 32 expls); PicArns Translation No **23** (1959) by G. Loehr 35a) P. Tavernier, *MP* **37**, 225-68 (1955) (Temperature of explosion, calorimetric value, force constant of propellants and coefficient of isentropic expansion in the gun barrel) [Transl & issued by Tech Info & Library Services, Ministry of Supply (GtBrit), Feb 1959 (TIL/T.4837)] 36) C.G. Dunkle's Lecture at Picatinny Arsenal, delivered on Dec 13, 1955, entitled "Introduction to Theory of Detonation of Explosives", pp 10-11 (Heats of deton & expln) 37) G.R. Handrick, *IEC* **48**, 1366-74 (1956) (Heats of combstn of org compds, by calcn and exptl methods) (70 refs) 38) J.A. Young et al, *Ibid*, 1375-78 (1956) (Heats of combstn of some organic nitrogen compds) (21 refs) 39) H.W. Sexton, "The Calorimetry of High Explosives", ARDE Rept (S) 4/56, April 1956 (Conf) (Not used as a source of info) 40) Dunkle's Syllabus (1957-1958), pp 231-37 (Source of chemical energy, Equilibria and oxygen balance, and Preferential oxidation and end products); 243-47 (Heats of explosion and detonation, Interrelationship); 248 (Definitions of heats of combustion, detonation, explosion, formation and reaction); 251-4 (Functional relationships of heat of explosion); 256-58 (Impetus and available energy); 269-74 (Factors affecting heat of detonation); 277-78 (Detonation calorimeters); and 356-62 (Prediction of energy yield) 40a) M.R. von Stein & J. Alster, *PATR* **2501** (1958) (An improved calcn of temp of explosion) 41) Cook (1958), pp 62, 392-7 (Equilibrium reactions in detonation); 404-5 (Heats of formation) 41a) Tomlinson Jr & Sheffield, *PATR* **1740**,

- Revision 1 (1958) (Heats of combstn & expln of expls of military interest) 42) J.F. Roth, *Explosivst* **1958**, 52 (Heats of expln & formation) 42a) Bandurín & Rukin (1959), 105-15 (Thermochemical calculations for permissible expls) 43a) Baum, Stanyukovich & Shekhter (1959), 80-81 (Definition of terms heats of formation, combstn and expln); 84-90 (Calc'n of heats of combstn); 90-92 (Heats of formation); 82-3 & 93-4 (Heats of expln); 94-6 (Calorimeters) 43b) Andreev & Belyaev (1960), 410-16. (Calc'n of heats of expln); 416-19 (Calc'n of heats of combstn of smokeless propnlts); 419-21 (Calc'n of heats of formation); 422 (Exptl determination of heats of explosion) 44) F.C. Gibson et al, "Detonation - Temperature Measurements", *Encyclopedia of Spectroscopy*, G.L. Clark, ed, Reinhold Pub Co, New York, NY (1960), pp 134-38 (Describes a method of measuring temps of deton in HE's by means of a modified grating spectrograph. Temps of deton of several expls are as follows: EDNA 5500°, PETN ca 5000°, NG 4000°, Permissible Dynamite 2600°K) 44a) Dunkle's Syllabus (1960-1961), pp 20a-c (Thermochemistry and energetics of detonation); 21.a-c (Heats of explosion and detonation); 22.a.c (Energy and temperature of detonation); and 23.2-c (Factors affecting heat of detonation) 44b) B. Lewis & G. von Elbe, "Combustion, Flames and Explosions of Gases", Academic Press, NY (1961) 44c) J.P. McCullough & W.D. Good, "Correlation of Heat of Formation Data for Organic Sulfur Compounds", *JPhysChem* **65**, 1430-32 (1961) 45) Fedoroff & Sheffield, *PATR* **2700**, Vol 2 (1962), pp C9 to C10 (Calorific values of explosives; C10 to C12 ("Calorimeter, Calorimetry and Calorimetric Determinations") (Included are determination of heats of combustion and of explosion and more than 60 refs) 45a) E.S.J. Tomezsko & J.G. Aston, "Calorimetry" in Kirk & Othmer, 2nd editn **4** (1964), pp 35-9 46) C. Giorgio, "Tecnica degli Esplosivi", DelBianco, Udine (1964), pp 32-4 (Calore di esplosione); 54-6 (Misura del calore di esplosione) 47) D.L. Ornellas et al, "A Detonation Calorimeter and the Heats of Products of Detonation of PETN". Its abstract is given in the 4th ONRSympDeton (1965), p 167. Complete paper is published in *Rev-SciInsts* **37**, 907 (1966) 48) Fedoroff & Sheffield, *PATR* **2700**, Vol 3 (1966), pp C447 to C449 (Thermochemical calculations for coal mining expls, which include heats of combustion, deflagration and explosion of such expls) 49a) Chemical Rubber Publishing Co, "Handbook of Chemistry and Physics", Cleveland, Ohio (1968-69) (See alphabetical index for heats of combustion, formation, vaporization, etc) 49b) N.A. Lange et al, "Handbook of Chemistry", Sandusky, Ohio (1968) (See alphabetical index under heats of combustion, formation, vaporization, etc) 50) C.G. Dunkle, private communication, Jan 1968
- Note:* International Critical Tables, Landolt-Börnstein Tables, US Bureau of Mines Publications and Picatinny Arsenal Reports on heats of combustion, heats of formation, etc are listed under Addnl Refs, which follow
- Addnl Refs on Heats of Combustion, etc.*
- A) C.A. Taylor & W. H. Rinkenbach, "Explosives: Their Materials, Constitution, and Analysis", *USBurMinesBull* **219** (1923), 188 pp (contain Heat of Formation data on substances used in expls)
- B) International Critical Tables, McGraw-Hill, NY, Vol 1 (1926), 102 (Heats of vaporization); 103-05 (H's of fusion); Vol 2 (1927), 458 (Heats of vaporization), 458-59 (H's of fusion); Vol 3 (1928), 201, 202, 204, 207, 255, 301 & 324 (Heats of vaporization); Vol 4 (1928), 9-18 & 172-83 (Heats of fusion); Vol 5 (1929), 130-34 (Heats of fusion), 135 (H's of vaporization), 162-69 (H's of combustn of organic compds), 170 (H's of reaction), 169-211 (H's of solution and h's of transition); Vol 6 (1929), 313 (Heats of reaction)
- C) G.B. Kistiakowsky, "Determination of the Heats of Combustion of Explosives", *OSRD* **293** (Dec 1941)
- [Detms made on 28 expls; heats of formation were calcd from these newly detd values; Q_{form} values were used to calculate heats

of expln & deton velocities for 11 expls]
 D) G.B. Kistiakowsky, "The Heats of Combustion of Explosives", OSRD **702** (July 1942) [Heats of combstn of 50 nitrated compds were detd; heats of formation were calculated; heats of expln & deton velocities were also calcd]

E) G. Stegeman, "Heat of Combustion of Explosive Substances", OSRD **5306** (July 1945) [Detn of Q_{combstn} of 21 expl compds & 2 nonexpl compds; heats of formation at const press were calcd]

F) W.R. Tomlinson, "Fundamental Properties of High Explosives. Thermodynamic Relations for Use in the Estimation of Explosive Properties", PATR **1651** (April 1947)

G) A.D. Little, Inc. "Report on Study of Pure Explosive Compounds", Cambridge, Mass [See Vol 2, p XI]

Part I. "Correlation of Organic Structure with Explosive Properties from Existing Data" (Jan 1947) [Contains nothing on Heats of Combstn, etc]

Part II. "Correlation of Thermal Quantities with Explosive Properties" (April 1947)

Part III. "Correlation of Composition of Mixtures with Performance" (May 1950)

Part IV. "Calculation of Heat of Combustion of Organic Compounds from Structural Features and Calculation of Power of High Explosives" (May 1952)

H) $H_E - H_F = H_{IC}$

| | | | |
|--|-----------|-----------|------------|
| | Heat of | Heat of | Heat of |
| | Explosion | Formation | Internal |
| | | | Combustion |

H_{IC} = calcd energy which would be released in passage from the elements in the proportion appearing in the chemical formula for the expl to the products which they would yield if fully reacted

I) ADL Rept 2, p 237 for Ammonium Picrate:

H_C **677.1 kcal/mol** (av value of all reported and assumed to be at const volume)

H_E **121.7 kcal/mol** calcd values with 184.5 kcal/mol lower value in bold type

H_E **495 kcal/kg** (Same as above)
 750 kcal/kg

H_F 94.5 kcal/mol (calcd)

H_{IC} 216.2 kcal/mol (calcd values)

879 kcal/kg (calcd values)

The bold type value is calcd assuming:

a) carbon is oxidized to CO

b) Hydrogen is oxidized to H_2O

c) CO is further oxidized to CO_2

The higher value is calcd assuming:

a) Hydrogen is oxidized to H_2O

b) carbon is oxidized to CO

c) CO is oxidized to CO_2

J) K.K. Kelley, "High-Temperature Heat-Content, Heat-Capacity, and Entropy Data for Inorganic Compounds", USBurMinesBull **476** (1949), 241 pp

K) J.P. Coughlin, "Heats and Free Energies of Formation of Inorganic Compounds", USBurMinesBull **542** (1954), 80 pp

L) Landolt-Börnstein Tabellen, Springer-Verlag, Berlin, Germany, II Band, 4 Teil (1961) (Various thermochemical tables)

Detonation, Helicoidal. See under Detonation, Spinning or Helicoidal

Detonation of High Explosives. See under Detonation (and Explosion) of Condensed (Liquid and Solid) Explosives

Detonation, Higher than Normal Velocity of. Same as Detonation, Supercelerity or Hyper-velocity of

Detonation; High-, Low-, and Intermediate Order, Velocities of. It has been known

since the end of the last century that some liquid expls (such as NG or NGc) and some gelatinous expls (such as Gelatin Dynamites) are capable of detonating at either low (1000-2000 m/sec) or high velocity (up to 8000 m/sec), depending on method of initiation. More recently it was found that the same phenomenon can occur, under certain conditions, with crystalline secondary, or even primary, expls

The low vel is in the vicinity of the vel of sound and thus corresponds to a relatively low pressure shock wave. The capability of slow detonation depends especially upon the physical state of the expl; for gelatinized

expls the presence of pores is decisive. Non-porous expls cannot detonate slowly. If an expl can deton with high and low velocities, then the low vel occurs only with weak initiation. No clear connection exists between the chge diam and low deton vel, as in the case of high vel. High vels can only be obtd for chge diams greater than values characteristic for each expl. In case of confinement, values can be lower

Taylor (Ref 7, p 156) states that in cases of two velocities, the velocity-diameter relation is not continuous; either high or low vels are possible, but intermediate stable vels do not occur in practice and there is a discontinuity betw the high- and low-velocity regimes (See Note, further in the text). Since the high velocity agrees closely with the limiting calcd velocity, it is clear that the high-vel regime corresponds to complete reaction of the compn with full energy release. It might be assumed consequently, that the low-vel regime involves only partial or incomplete reaction of the expl, which view is supported by the fact that unreacted material can frequently be detected after the low-order deton

Note: Accd to Cook (Ref 12, p 54), there is an *intermediate regime*, but so far it has been observed only in TNT. In table 3.4 entitled "Transient Conditions in TNT", Cook gives some examples of which the following are selected:

- 1) Fine-grained TNT of density 0.8, in a chge 4.9 mm diam, initiated with "Knotted Primacord" had an initial vel of 1400 m/sec at a distance from initiator 53 cm; then, at a distance 8.1 cm the vel of 3500 was reached and after this a steady regime with vel 4335 m/sec was established
- 2) TNT, 50% fine & 50% coarse (-6+8 mesh) of density 1.12 and chge diam 4.8 mm, initiated with "Knotted Primacord" had initial vel of 2070 at the distance from initiator of 5.0 cm, then at the distance of 7.4 cm the vel was 3190 and after this a stable regime was established with vel 5150 m/sec. The three-regime transient phenomena are also illustrated by framing-camera results for cast TNT shown in Fig 3.13, p 55. Here

the initial (low-order) regime is at vel 4300 m/sec, the intermediate at 4700 and normal high-order at 6700 m/sec. The transition from low- to intermediate-order occurred at 5 cm distance from initiator and from intermediate- to high-order at 9 cm distance from initiator

Dunkle (Ref 11, pp 279-80) stated that Herzberg & Walker (Ref 2a) found evidence of at least two types of low-order deton; Type I, most easily observed in low-density chges, goes to high-order somewhat gradually and quite uniformly over the whole wave front or charge cross section. Type II, apparently occurring in every initiation by detonators for the first few mm and, near the limit, for greater distances, goes over to high-order in a very restricted area

In TNT pellets the initial Type II low-order detonation does not lead immediately to the final high order but to an intermediate level, of almost normal rate but of very low shock luminosity. A luminous strip due to the collision of the shock waves of two low-order detonations in TNT is observed in the simple dark space in some still photographs. Initiation at slightly below the limit, in all of the expls studied, produces low-order detons that fade after traversing a short distance and the wave fronts show a strong shock effect. In TNT pellets the intermediate-order may also fade

Poulter (Ref 10, as quoted by Dunkle, Ref 11, p 280) suggested in the 1956 unclassified portion of his paper that the capability of deton at low-order is much more general than was supposed up to that time, maybe even universal, and that the process can be controlled and utilized. He referred in the 1957 paper to the initiating of deton in an HE by impacting it with a metal plate. Under some conditions high order detonation is initiated at once, whereas under closely similar conditions and with the same total energy available, the high order may appear only after a delay of a fraction of a microsec, or the low-order may propagate as such for some microsecs and then either quench or go over to high-order. Poulter also suggested that the time-pressure profile of the shock

pulse striking the expl, as well as the impulse, plays an important part in determining the type of deton that is going to take place. (For further info on this subject, see Ref 11, pp 280-81 and Ref 15, pp 23b & 23c)

Accdg to Urbański (Ref 1), some smokeless proplnts in the form of scales loaded in an iron tube, at density 0.5 to 0.7 and initiated with a cap & 20 g of PA booster detonated with a vel of 1000-1500 m/sec; the same proplnts loaded in the same type of tube but at density above 1.0 detonated at vels betw 7000 & 7700 m/sec. The vels in both cases proceeded at constant rate thruout the chges which were 10 in long

Investigation by Ratner & Khariton (Ref 2) of deton vels of liquid expls (such as NG & NMe) has shown that the low vel (on the order of 1000 m/sec) could change to a high vel (on the order of 6000 m/sec) in a discontinuous way and this jump could occur reversibly. The reaction may change also to a nonstable combustion (which does not have the characteristics of a detonation) with a flame vel of ca 700 m/sec. The smaller the diameter of the tube, the lower the velocity. When a chge of a large diam is in contact with a 2nd chge of smaller diam, and the chge is initiated in the larger diam tube, the high vel might turn into a low one when the wave reaches the narrow tube.

If a chge is initiated in a narrow tube, its low deton vel will "jump" to the high one when the wave reaches the large diam tube

Jones & Mitchell (Ref 4) reported that flaked TNT loaded at density 1.0 in a tube 1.2 in diam and initiated with a No 6 cap detonated at the low vel of 1120 m/sec. The same chge of flaked TNT initiated with a cap & 12.5 g of Tetryl booster detonated with a vel of 3660 m/sec. The length of tube was 10 in and the vel was constant in both cases thruout the length of the tube

Accdg to Dunkle (Ref 11, p 279), the above investigators reported also that in solid expls such as TNT or Tetryl, as well as in liquid or gelatinous one, an initial unstable phase of deton may change abruptly to a higher level. The duration of the

initial slow phase shortens with increasing strength of initiator, and may decrease to zero with high-density compressed cartridges. It lengthens with decrease in cartridge diam or with use of sufficiently coarse granulation of expl. In this way a uniform and stable low vel of deton may exist in which chemical reaction appears to be incomplete. Often regimes at lower rates are very stable and can be maintained for relatively long periods. Since the high rate approaches the limiting calcd vel and appears to correspond to complete chem reaction with full energy release, it is sometimes called the normal rate

The wide range of results obtained in the apparently straightforward calorimetric determinations of TNT {heat of explosion 689.3 cal/g, gaseous products 960.3 cc/g (Picatinny Arsenal Physico-Chemical Unit Report No 52-HI-595, 4 Mar, 1952) as against heat of explosion 1080 cal/g, gaseous products 730 cc/g [Picatinny Arsenal Technical Report (PATR) 1740, Rev 1(1958), p 319]} suggests the occurrence of two different chemical reactions, possible similar to the following in the two respective cases:

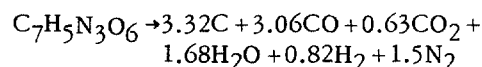
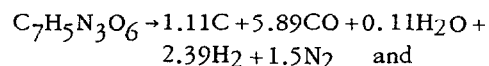

These may approximate respectively the "low-order" and the "high-order" detonation. The conditions in the first determination, small sample size and low loading density, favor the low-order process, to which TNT is particularly susceptible in any event

Stresau (Ref 8), investigated detons of primary expls and came to the conclusion that under conditions of very high loading density and high radial confinement, and when marginally initiated, LA & MF were found to react in an unusual manner. The propagation rate of the reaction was found to be between 1400-1700 meters/sec as contrasted with a deton vel of over 5000 meters/sec for the same materials at the same loading densitics, when more vigor-

ously initiated. The interior of the hole thru which such a reaction has passed is smooth & lustrous, while one thru which a normal deton has passed is black and riddled with longitudinal cracks. Experiments with various confining media & column diameters show that these have little, if any, effect upon the propagation vel but make adjustments of other conditions necessary in order to cause this type of reaction. Possible mechanism of this type of reaction is discussed

Accdg to Baum et al (Ref 13, p 297, it has been known for a long time that liquid nitrated esters (NG, NGc & MeN) develop high velocities (6000-8000 m/sec) when initiated with strong detonators (such as No 8 LA), provided the chges are of sufficiently large diam. The same expls develop only ca 1500 mm if diams are small and detonators weak. Investigations recently conducted by Bobolev have shown that this phenomenon takes place also with solid expls, such as PA and solid NG in powder form

Baum et al (Ref 13, p 297) also stated that Lawrence (probably R.W. Lawrence of Hercules Powder Co) has shown that low deton vel increases with decrease of chge density which is opposite to what happens with high velocity. Tsibul'skii has shown that some permissible NG expls can develop high vel of 6000-8000 m/sec and low velocity reaching 3000 m/sec. It depends on the strength of initiator and diam of chge. Two deton vels were also observed for some other industrial expls. It has been observed

that at low-order deton the decomposition of expl is usually incomplete

Andreev & Belyaev (Ref 14, p 207) give a table of low-, intermediate- and high-deton vels of NG which was initiated by various strength detonators. Vel was detd by Dautriche Method

Note: No 2 MF Detonator contd 0.4 g MF; No 6 - 1.0 g MF; and No 8 - 2 g MF or LA

Accdg to Dunkle (as reported in Ref 60a, p 12), in some propellants detonation at a lower rate may sometimes be initiated on passage of a detonation wave of normal velocity into a narrowed column of charge (Ref 10a, p 12). This is not the "diameter effect" noted under *Detonation, Critical and Limiting Diameters in*, for the difference between the two velocities (a factor of 4 in NG) is far outside the range of variation attributed to lateral energy loss. Furthermore, not only is the low velocity fully as stable as the high velocity when initiated in small-diameter charges, but it often can even be propagated in a charge wide enough to maintain the high-velocity wave

It was suggested that there may be several different reaction mechanisms in parallel, differing greatly in reaction rate, end products, and energy evolution. Given a long enough time, all of the reactions among the products reach equilibrium. If on the other hand the time available for reaction is short, as in a small-diameter charge, some reaction mechanisms are ruled out; it is quite possible that with increase in the diameter a value may be reached at which a very slight further increase may lead to

Table

| Charge diam, mm | Deton vel D, m/sec, initiated with | | | |
|-----------------|------------------------------------|-------------------|-------------------|-------------------|
| | No 2 MF Detonator | No 6 MF Detonator | No 8 MF Detonator | No 8 LA Detonator |
| 6 | 890;950 | 810; 890; 1030 | 1350 | 8130 |
| 12 | 2530 | 1940; 2090 | 1780 | 8700 |
| 18 | 2130 | 1970; 2030 | 1750 | 8250; 8390 |
| 25 | 2190 | 2020; 2030 | - | 8130 |
| 32 | 1760 | 1780; 2010 | - | 8140 |
| 38 | - | 1910 | - | - |

a large jump in energy evolution and wave velocity, due solely to the chemical mechanisms previously ruled out as too slow

Thus, as noted in Ref 12a, p 4, the chemical reaction in normal detonation includes a fast first stage and a slow second stage. The low-order detonation is supported by only the first; the second is too slow for completion in the available time or is quenched as a result of lateral expansion or other loss mechanism

The fast reaction may be caused by abnormally high temperatures behind the shock front. Such temperatures are attainable by either a hot-spot or a grain-burning mechanism, even though the latter requires a finite induction period. Thus, initiation in the surface layer meets the requirements of a fast first-stage reaction, and the normal grain-burning process could follow as the slow second stage. In a sense, the ignition zone itself acts as a hot spot

Three papers of the 4thONRSympDeton (Ref 17), among others, concern low-velocity detonation. R.W. Watson et al of VanDolah's group (Proceeding, pp 117-25) stressed the importance of jetting in the bubble in the liquid ahead of the shock front. A.B. Amster et al of Stanford Res Inst (Proceedings, pp 126-34) seemed to consider wave interaction in the walls fore-running the front more important. N. Griffiths and V.C. Broom (Proceedings, pp 462-72) noted the balance between energy release by the shock-induced slow chemical reaction and energy loss from the system; the energy release is determined by the intensity of the applied shock, and the loss is minimized by delay in arrival of the subsequent rarefaction and hence by great length of reaction zone. It was suggested that the probability of consistent low-order reaction is associated with reaction zone length

Refs: 1) T. Urbański, *SS* **34**, 103 (1939) (Low- & high-deton vels of smokeless propnlts) 2) S.B. Ratner & J.B. Khariton, *DoklAkadN* **40**, 293 (1943) (Low- and high-deton vels of NG & NMe) 2a) G. Herzberg & G.R. Walker, "Optical Investigations of Initiation and Detonation", Univ of Sas-

katchewan, Canada, Rept Prepd on Project **XR-84**, March 1945-August 1946; *Nature* **161**, 647-48 (1948) 3) R.W. Lawrence, *PhysRev* **72**, 180 (1947) (Low deton vel in NG and other liquid nitric esters) 4) E. Jones & D. Mitchell, *Nature* **161**, 98 (1948) (Spread of deton in HE's) 5) T. Urbański, *Przemysl-Chem* **4**, 487 (1948) (Review of works on two vels conducted betw 1939 & 1948) 6) T.C. Tanter, *Nature* **162**, 335 (1948) & **174**, 81 (1954) (Influence of surface chilling on the deton behavior of TNT; low- & high-deton vels were observed) 6a) J. Taylor, "High and Low Detonation Velocity Regimes in Condensed Explosives", *PrRoySoc* **204A**, p 30-31 (1950) (In the opinion of the author it appears that the method of decomposition in low- and high-velocity regimes is different. He believes that the low velocity regime is explainable by deflagration on the surface of the grains or films of the explosive initiated by hot spots produced by the heating of the interstitial gases, whereas the high-velocity region is produced by a bulk thermal decomposition thruout the explosive material induced by extremely high pressures) 7) Taylor (1952), 156-68 (High- and low-velocity regime) 7a) F.P. Bowden & A.D. Yoffe, "The Initiation and Growth of Explosions in Liquids and Solids", Cambridge, England (1952), p 91 8) R.H. Stresau, *PhysRev* **87**, 234 (1952) & *CA* **48**, 8543 (1954) (Low detonation velocity of certain primary expls) 9) R. Schall, *ZAngewPhys* **6**, 470-75 (1954) ("Die Stabilitätlangsamere Detonationen"); *The Engrg Index* (1955), 362. Engl transl by Sgt A. Himsl, entitled "Stability of Detonations", Tech Transl No 20, Scientific and Technical Information Branch, FREL, PicArnsn, Dover, NJ (1958) 10) T.C. Poulter, "A Report on Recent Basic Studies on Detonation of High Explosives", Proceedings of the Shaped Charge Symposium at BRL(U), BRL **905**, May 1956 (Conf) and SRI Poulter-LabTechRept **010-57** (1957); SAC 14th Meeting, 25-26 April 1957 (Conf) (Unclassified paper on pp 83-92) 10a) M.H. Boyer & R.A. Grandey, "Study of Detonation Behavior of Solid Propellants", Aeronu-

tronics Systems Inc, First Quarterly Report, Navy BuOrd Contract NOrd-17495, Publication No U-121, 15 Nov, 1957 (77001), p 12

11) Dunkle's Syllabus (1957-1958), 279-81 (Low-, high- and above normal detonation rates) 12) Cook (1958), 52 & 55 (High-order detonation); 53-6 (Intermediate-order deton); 59 (Low-order deton) 12a) M.H. Boyer & R.A. Grandey, "Study of Detonation Behavior of Solid Propellants", Aeronutronics Systems Inc, 8th Quarterly Report, Publication No U-580, August 15, 1959, p 4

13) Baum, Stanyukovich & Shekhter (1959), 297 (Two detonation velocities) 14) Andreev & Belyaev (1960), 206-08 (Low-, intermediate- and high-detonation velocities of NG and some Dynamites) 14a) L.D. Savin et al, "Nonideal Detonation of Ammonium Nitrate-Fuel Mixtures, 3rdONR-SympDeton (1960), pp 309-25 15) Dunkle's Syllabus (1960-1961), pp 23b & 23c 16) H.L. Selberg & T. Sjolín, Explosivst, **9**, 150-54 (in Engl) & 154-57 (in Ger) (1961) (Low and High Velocity of Detonation in Metal Tubes) 16a) G.S. Sosnova et al, DoklAkadN **149**, 642-43 (1963) & CA **59**, 375-76 (1963) (Light emission by a low-velocity detonation front in NG) 16b) G.E. Seay, "Shock Initiation of Granular Explosives Pressed to Low Density", 9thSympCombstn (1963), pp 530-35 16c) W.E. Gordon, "Detonation Limits in Composite Explosives", 10thSympCombstn (1965), pp 833-38 17) FourthONRSympDeton (1965). Titles of three papers and pages indicated in the text 18) D. Price, "Contrasting Patterns in the Behavior of High Explosives", 11thSympCombstn (1967), pp 693-702 19) A.N. Dremin, "Critical Phenomena in the Detonation of Liquid Explosives", 12thSympCombstn (1969), pp 691-99 20) C.L. Mader, "One- and Two-Dimensional Flow Calculations of the Reaction Zones of Ideal Gas, Nitromethane, and Liquid TNT Detonations", Ibid, pp 701-10 21) J.J. Erpenbeck, "Theory of Detonation Stability", Ibid, pp 711-21 22) R.W. Watson, "The Structure of Low-Velocity Detonation Waves", Ibid, pp 723-29 23) R.W. Woolfolk & A.B. Amster,

"Low-Velocity Detonations: Some Experimental Studies and Their Interpretation", Ibid, pp 731-39 24) D. Price and A.R. Clairmont Jr, "Explosive Behavior of Nitroguanidine", Ibid, pp 761-70 25) L.G. Bolkhovitinov et al, "Initiation of Detonation in Low-Density Trotyl by Air Shock", Ibid, pp 771-77

Detonation, Hollow- or Shaped-Charge Effect. See under DETONATION, MUNROE-NEUMANN EFFECT

Detonation, Hot Spot, Initiation of. See under Detonation, Spot or Hot Spot, Initiation of

Detonation; Hugoniot Curves (or Hugoniots), Hugoniot Equation and Hugoniot Relation in. See under DETONATION (AND EXPLOSION), THEORIES OF and also paper of M.W. Evans & C.M. Ablow, ChemRevs **61**, 138 (Fig 6), 139 (Fig 7), 140 (Fig 8), 147 (Fig 17), 148 (Fig 18) & 152 (Fig 22) (1961)

Detonation, Hugoniot Function. Properties of Hugoniot Function are described by R.D. Cowan in JFluidMech **3**(5), 531-45 (1957)

Detonation, Hydrodynamic and Hydrothermodynamic Theories of. See under Detonation (and Explosion), Theories of

Detonation, Hypervelocity of. See Detonation, Supercelerity (Hypervelocity) of

Detonation, Hypervelocity Wave Phenomena in Condensed Explosives. See Detonation, Flash-Across, Heat Pulse and Hypervelocity Phenomena

Detonation, Ideal and Nonideal. Accdg to Cook (Ref 2, p 44), an *ideal detonation* corresponds to the theoretical maximum or hydrodynamic value D^* . This maximum velocity D^* is subject to direct experimental determination; it is the steady value attained at a sufficiently long distance from the initiator in a tube or charge of diameter sufficiently large that further in-

crease in either length or diameter will not cause an increase in velocity. "A *nonideal detonation* refers to a steady-state (long charge length L) wave propagating at a velocity lower than the ideal velocity D^* . It is associated with the rate of conversion of the explosive to its products of detonation and to lateral heat and pressure losses"

Three theories of nonideal detonation have been advanced, namely the *nozzle theory of Jones*, the *curved-front theory of Eyring* and the *geometrical model theory of Cook*, known also as the *head theory of Cook*. All three theories are described separately in this section

An "ideal detonation" is also known as a *Chapman-Jouguet (C-J) detonation*, while a "nonideal detonation" may be called a *Non-Chapman-Jouguet detonation*. As an example of an expl undergoing an ideal detonation may be cited finely granulated RDX, and as examples of nonideal detonations may be cited AN/Fuel expls (Ref 3) and 90/10 - AN/RDX mixture (Ref 4)

Accdg to remarks of Dunkle (Ref 8), an ideal detonation can be visualized as a *steady-state* process, in a frame of reference in which the detonation zone is stationary and time-invariant, with the undetonated explosive being "fed into" the front at the *detonation velocity* D and with laminar flow of the products away from the C-J plane; the rear boundary of the reaction zone is at velocity $(D-u)$, where u is the *particle velocity* of the products in stationary coordinates. By the *Chapman-Jouguet rule*, $D-u=c$, the local *sonic velocity* at the C-J plane. That is, the velocity of the products with respect to the detonation front is sonic at the C-J *temperature and pressure*. Thus, even if the products were expanding into a vacuum, the *rarefaction wave* would never overtake the *detonation front* as long as any undetonated explosive remains

Removal of the restriction to "linear" or "one-dimensional" process may result in a theory applicable to a broader variety of transformations and therefore capable of

describing a larger number of combustion modes. Experimentally, as noted by Craig (Ref 5, p 863), one can never achieve a detonation that is truly either one-dimensional or steady-state. In this sense, all detonations are "non-Chapman-Jouguet" detonations. There has been much discussion lately (such as by Davis et al in Ref 6, pp 84-5) of the inadequacy of the *Chapman-Jouguet model*, and considerable dissatisfaction with the foundations of the *Chapman-Jouguet theory* itself. Although the *Chapman-Jouguet state* is mathematically plausible but physically unrealizable, the C-J model proved to be useful as a limiting case, and for relating detonation velocity, detonation pressure and density, when employed with discretion (See also "Detonation, Steady State" and "Detonation, Strong and Weak") Refs: Dunkle's Syllabus (1957-1958), pp 209, 284, 287 & 297 2) Cook (1958), pp 44-8, 59, 123, 128, 153 & 211-13 3) L.D. Sadwin et al, "Nonideal Detonation of Ammonium Nitrate-Fuel Mixtures", 3rd-ONRSympDeton (1960), pp 309-25 4) Dunkle's Syllabus (1960-1961), p 23e (Detonation of 90/10 - AN/RDX mixture is nonideal in *point-initiated* charges, while detonation of fine granular RDX may be considered as ideal when point-initiated) 5) B.G. Craig, "Measurements of the Detonation-Front Structure in Condensed-Phase Explosions", 10thSympCombstn (1965), pp 863-67 6) W.C. Davis et al, "Failure of the Chapman-Jouguet Theory for Liquid and Solid Explosives", 4thONRSympDeton (1965), pp 84-5, Abstract and Comments to the paper published in Phys-Fluids 8, 8169(1965) 7) F. Wecken, "Non-ideal Detonation with Constant Lateral Expansion", Ibid, pp 107-16 (18 refs) 8) C.G. Dunkle, private communication (Nov 1968)

Detonation (and Explosion), Ignition of Explosives and Propellants to. All propellants, pyrotechnic compositions and most "low explosives" can be ignited to burn (See Vol 2 of the Encycl, pp B343 to B359, under Burning and Burning Characteristics

of Explosives, etc and Vol 3, pp C425 & C426, under Combustion). In many cases ignition results in "deflagration" (See Vol 3, pp D38 to D40) and sometimes (when confined or taken in a large quantity) this develops into detonation [See Detonation (and Explosion), Development from Deflagration, in this Volume]

Some unconfined high expls can also be ignited to deflagration especially if they are in a molten condition (such as TNT), or spread in a thin layer (such as MF or Diazodinitrophenol). In many cases deflagration develops into detonation [See also Detonation (and Explosion), Initiation of] *Refs:* 1) F.P. Bowden, "The Initiation of Explosion and Its Growth to Detonation", *PrRoySoc* **204A**, 20 ff (1950) 1a) A.F. Belyaev, *ZhPraktKhim* **23**, 432 ff (1950). Engl transl by Consultants Bureau, NY, pp 451-58 (Ignition of expls and transition from combstn to deton) 2) M.A. Cook & F.A. Olsen, "Ignition of Double-Base Propellants by Detonating Gases", *TechRept* **4** (1954), Univ of Utah, ERG, Contract N-1235-80062 3) W.N. Bryan et al, "Ignition of Double-Base Propellants by Detonating Gases", *TechRept* **5** (1955), Univ of Utah, ERG, Contract N-123-60530S-1980A 4) C.H. Johansson et al, "Ignition of Explosives", pp 606-08 in the 6thSympCombstn (1957) & *CA* **52**, 21107 (1958) 5) Dunkle's Syllabus (1957-1958): Ignition processes are treated under initiation, such as on pp 151-61 & 191-202 6) M.H. Wyatt et al, *PrRoySoc* **246A**, 189-96 (1958) (Ignition of primary expls by electric discharges) 7) Cook (1958), 2 (Ignition of low expls); 197 (Ignition of deflgrn in proplnts by detonating gases); 199 (Ignition index); 200 (Ignition-threshold pressure); 203 (Ignition time lag) 8) C. Rosen, *JChemPhys* **30**, 298-303 (1959) (Ignition of combustible gases) 8a) B. Reitzner, "Influence of Silver Coating on Ignition Behavior of Colloidal Lead Azide), *PATR-FRL-TR2* (1960) 9) Dunkle's Syllabus (1960-1961), p 14g (Mentions an ignition by ball lightning, taken from Russian literature); other ignition processes are treated under initiation,

such as on pp 13.a-g and 17.a-f 10) V.B. Librovich, *ZhPriklMekhan i TekhnFiz* **1963** (6), 74-9 & *CA* **60**, 14325 (1964) (Ignition of propellants and explosives) 11) G.D. Dorough et al, "Ignition of Explosives by Low Velocity Impact", *Proceedings of the International Conference on Sensitivity and Hazards of Explosives*, London, October 1963 12) L.G. Green & G.D. Dorough, "Further Studies on the Ignition of Explosives", 4thONRSympDeton (1965), pp 477-86 13) G.P. Cachia, "Summary Paper on Initiation, Ignition and Growth of Reaction", *Ibid*, pp 512-16 14) F. Solymosi & K. Fónagy, "The Effect of Cadmium Oxide and Cadmium Perchlorate on the Decomposition and Ignition of Ammonium Perchlorate", 11thSympCombstn (1967), pp 429-37 15) P.W.M. Jacobs & A. Russell-Jones, "The Thermal Decomposition and Ignition of Ammonium Perchlorate + Copper Chromite", *Ibid*, pp 457-62 16) P.A. Urtieu & A.K. Oppenheim, "Detonative Ignition Induced by Shock Merging", *Ibid*, pp 665-70 17) C.G. Dunkle, private communication, Jan 1968

Detonation (and Explosion), Ignition of Gases to. See under Detonation (and Explosion) of Gases

Detonation (and Explosion) by Impact (or Shock). See Vol 1 of Encycl, p XVII under Impact (or Shock) Sensitivity Test and Vol 2, pp B332 to B340 and Bullet Impact or Rifle Bullet Tests

See also Refs 10, 18, 18a, 21, 23, 24, 26, 27, 28, 30, 31, 32, 33, 34a, 35, 35b, 35c, 36a, 38b, 41, 42 & Addnl Ref G in this Section under Detonation (and Explosion), Initiation (Birth), and Propagation (Growth or Spread) in Explosive Substances

Fig 45 shows a plot of drop height in inches vs cumulative percent expls for 5 common expls [from Dunkle's Syllabus (1957-58), p 150]

Detonation (and Explosion), Impetus and Available Energy. Impetus, in the physical sense, may be defined as the "force" with which a moving body tends to maintain

IMPACT SENSITIVITY OF HIGH EXPLOSIVES USING PA APPARATUS

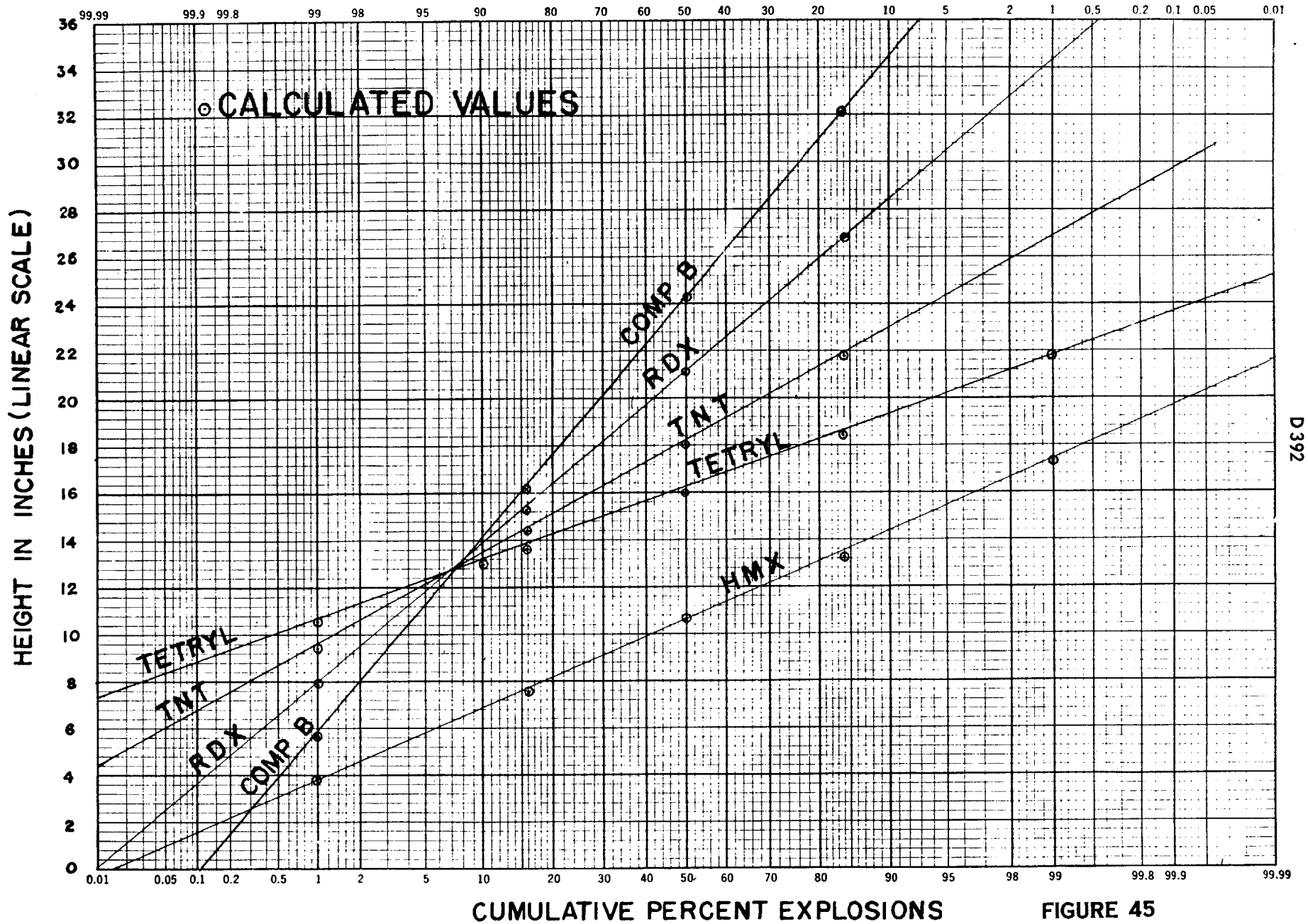

D 392

FIGURE 45

its velocity and overcome resistance

Dunkle (Ref 1, p 257) in discussing the subject entitled "Impetus and Available Energy" gives the following equation for the heat of explosion at const volume:

$$Q_E^v = \frac{nRT_v}{\gamma-1} \cdot \frac{T_v - T_0}{T_v}$$

where (T_v) is adiabatic, isochoric temp of expln in K° ; (T_0) = room temp ($298^\circ K$); (n) = number of gram moles of product per gram; (R) = the universal gas constant equal to 1.987 cal/mole per $^\circ C$ and (γ) = adiabatic exponent in the polytropic equation of state of the detonation products. The quantity (nRT_v) is sometimes called "power" (See Cook, p 271) or "explosive force", though expressed in units of neither power nor force but of energy or heat. In the opinion of Dunkle, a better term is *impetus*; it is usually given in cal/g or foot-pound/pound, but can also be expressed in liter atmospheres per gram or cubic foot atmospheres per pound. In the latter units "impetus" is numerically equal to the volume that unit weight of the explosion products, if ideal gases, would occupy on isothermal expansion at (T_v) to a pressure of 1 atm. The "work" done in this expansion would depend on the conditions. Work done would equal impetus only if the expansion were against an external pressure of 1 atm thruout
 Refs: 1) Dunkle's Syllabus (1957-1958), p 257 2) Dunkle, private communication, Jan 1968

Detonation (and Explosion), Impulse in.

Impulse (or momentum), in the physical sense, may be defined as the product of force and the time during which it acts

Dunkle (Ref 8) defines it as mass times velocity equals force times time and gives the following equation:

$$mq = ft$$

where (m) is mass, (q) - velocity, (f) - force and (t) - time

The term is sometimes loosely used to mean "impact" and "shock" as, for instance, in Ref 3, pp 161-62 (Thermal effects

of impact) and pp 291-92 (Initiation by shock)

The so-called "positive impulse" in a shock wave is the area under the pressure-time curve: "Phases of a Shock Wave" represented as shaded area in Fig 15, p 51 of Ref 3 and in Fig on p B181 of this Encycl, Vol 2. It is actually impulse per unit area (Ref 8)

The so-called "impulse function" is represented by the expression:

$$(P - \dot{m}q)A$$

where (P) is pressure, (A) - the area, (\dot{m}) - mass velocity and (q) - velocity (Ref 3, p 101 & Ref 8)

The so-called "specific impulse" (I_{sp}), employed in jet propulsion can be represented by the expression Ft/mg , where (F) is the thrust, (t) - time interval and (mg) - unit weight. It can be defined as "thrust per unit rate of consumption of propellant" (Ref 3, pp 253-54)
 Refs: 1) H. Semat, "Fundamentals of Physics", Reinhart & Co, NY (1957), p 99
 2) W.E. Bron et al, "New Method for Recording Explosion Impulse Effects on Solids", ASTM Bulletin, Feb 1957, 50 (TP38)
 3) Dunkle's Syllabus (1957-1958), p 51 (Positive impulse); 101 (Impulse function); 161-62 (Thermal effect of impact); 253 (Specific impulse); 291-92 (Initiation by shock) 4) Cook (1958), 96 (Impulse in deton of head of gases); 95 & 98 (Impulse-charge length relations); 97 (End effect is defined as the impulse loading of a target at the end of cylindrical charge); 326 (Impulse of air blast waves); and 327 (Impulse of underwater shock waves) 5) Baum, Stanyukovich & Shekhter (1959), 432-38 (Impulse obtd on reflection of deton wave from a wall); 438-40 (Experimental methods of determination of impulses 440-44 (Specific impulse - see next item); 452-58 (Calculation of impulses acting on the sides of confining vessel) 6) Andreev & Belyaev (1960), 265-76 (Starting impulse and mechanism of initiation of expln); 289-93 (Action of expl impulse on expls); 332-37 (Effectiveness of starting impulse) 6a) Dunkle's Syllabus (1960-1961), p 22c (Addnl

discussion on impetus) 7) PATR 2700, Vol 2(1962), p B181-L (Impulse in air blast)
8) Dunkle, private communication, Jan 8, 1968

Detonation (and Explosion), Impulse, Specific.

M.A. Sadovskii & P.F. Pokhil of Russia (as quoted by Baum et al in Ref) detd by means of the ballistic pendulum, represented in Fig 146, p 439 of Ref, specific impulses of several HE's, among them TNT and RDX (phlegmatized) and they proposed the following formula for "specific impulse":

$$I = kP \frac{\omega}{\Omega}$$

where k =coefficient depending on power of expl; P =wt of chge in kg; ω =surface of charge in cm^2 , which is in contact with the pendulum and Ω =total surface of the chge

Assuming that the quantity of products of deton is proportional to their velocity and this, in turn, is proportional to deton velocity, D , the formula may be written as:

$$I = k_1 DM \frac{\omega}{\Omega}$$

where k_1 =constant and M =mass of the chge

Further work on determination of specific impulse was conducted by Verbovskii and following are some of his values, in comparison with density and deton velocity

Table

| Explosive | Density g/cm^3 | Deton Vel m/sec | Sp Impulse kg. sec/cm |
|--------------------|----------------------------|--------------------------------|-----------------------------------|
| TNT | 1.30 | 6025 | 0.285 |
| | 1.35 | 6200 | 0.295 |
| | 1.40 | 6320 | 0.303 |
| | 1.45 | 6440 | 0.311 |
| | 1.50 | 6440 | 0.320 |
| RDX (phlegmatized) | 1.20 | 6400 | 0.312 |
| | 1.25 | 6640 | 0.325 |
| | 1.30 | 6870 | 0.336 |
| | 1.35 | 7060 | 0.343 |
| | 1.40 | 7350 | 0.355 |

Verbovskii showed also that there are nearly straight-line relationships betw specific impulse and detonation velocity (Graph

147, p 441 of Ref) and betw specific impulse and loading density (Graph 148, p 442).

There are also some relationships betw specific impulse and diameters and lengths of charges, as can be seen from graph 149, p 442 and Table 95, p 443 of Ref. Relationships betw specific impulse and method of confinement are given in Table 96, p 444

An example of method of calcn of sp impulse is given on p 443 of Ref 1 (See also Ref 2)

Refs: 1) Baum, Stanyukovich & Shekhter (1959), 438-44 & 452-68 2) R.R.V. Wiederkehr, "A General Method for Calculating Specific Impulse of Propellant Systems", Reports Nos AR-1S-60 & AR-3S-61, Computation Research Laboratory, Dow Chemical Company (1960-1961)

Detonation (and Explosion), Impulse Specific in Jet Propulsion (I_{sp}). See under Detonation (and Explosion), Impulse in

Detonation (and Explosion), Incident or Initial Wave in Blast. See Vol 2, p B182-L and Fig on p B183

Detonation (and Explosion), Induction Period in Initiation of Explosives and Propellants.

Initiation is not an instantaneous process, but a few microseconds always elapse between the impulse and detonation or explosion. This *delay of initiation*, known as *induction period*, depends on the sensitivity of explosives and varies greatly. For example, when the following expls were initiated at the US Bur Mines from an identical source, the induction period of PETN was 5 microseconds, of RDX 10, Tetryl 15 and TNT failed to detonate

The description of work done on delays to ignition at the USBurMines is given here in Refs 1 & 2

See also Delay to Ignition and Its Temperature Coefficient in Vol 3 of Encycl, pp D53-D54 and Notes 1 & 2, which are given after the Refs

Refs: 1) C.M. Mason et al, "The Physics and Chemistry of Explosive Phenomena", USBurMines, ProgrRepts April 1, 1949 to

Dec 31, 1949, Contract NA onr 29-48, Project NR 053 047 2) F.C. Gibson et al, "Studies on Deflagration to Detonation in Propellants and Explosives", USBurMines-SummaryRept 3863 (1962), ARP Order Nos 44-59 & 44-61 3) C.G. Dunkle, private communication, Jan 1968

Note 1: Accdg to Dunkle's personal opinion, which differs from that of many others in the field, (except some opinions expressed at the 4thONRSympDeton, as explained in Note 2):

"Initiation by *shock* can be instantaneous, or practically so, if the shock is strong enough. In secondary explosives the essential factor appears to be a pressure increase, specifically a pressure "jump" of 25-50 atm"

"Such a shock either has to be applied from outside, or develop within the system as the result of a burning reaction (deflagration). In initiation by *thermal means* there is always an induction period, no matter how abruptly the heat is applied, for all it can do is to start a burning reaction which *develops into* detonation after an induction period. Even in the heavy metal azides, the direct result of a thermal initiation mechanism is stated to be a burning reaction ["Initiation of Lead Azide by High-Intensity Light", by J. Roth, JChemPhys 41, No 7, 1929-36(1964)] with a very rapid transition to detonation. Typical initiation delays in Lead Azide are of the order of 1 microsecond, and the product of the energy absorption rate and the initiation delay is constant. To achieve high-order detonation in secondary explosives, it has always been necessary to allow much longer delays in order to let the low-order process initially started "jump" to high order" [Compare with Detonation (and Explosion) by Influence]

Note 2: In a review of 23 papers on initiation, ignition, and growth of reaction presented at the 4thONRSympDeton by G.P. Cachia, p 513, he referred to "the clear indication that shock initiation can proceed either by a continuous intensification of the entering shock, or via an intermediate burning phase which may last tens of microseconds". When initiation is achieved by

strong shocks, detonation appears to develop directly from the initiation shock

Section 6

DETONATION (AND EXPLOSION) BY INFLUENCE OR SYMPATHETIC DETONATION

(Explosions-übertragung oder Explosions-fernwirkung in Ger; Détonation par influence ou Explosion sympathique in Fr; Detonatsiya chérez vliyaniye in Rus; Distanza di esplosione o di colpo ed esplosione per simpatia in Ital; Explosion por influencia o por simpatia, in Span) [See also Detonation (and Explosion) Distant Effect of]. Under these terms is known the initiation of detonation (or explosion) in a charge of explosive, not provided with an initiator, by the detonation (or explosion) of another chge (of the same or different expl), located some distance away - without being hit by flame, burning embers or fragments. The chge detonating by influence is known as the *receptor*, whereas the chge causing the sympathetic detonation is called the *donor*. The detonation of receptor follows so closely that of donor as to be undistinguished from it. The maximum distance at which such detonation takes place, when transmitted thru the air, is called *air gap* or simply *gap*

Accdg to Dunkle (Ref 29): "Sympathetic detonation must be due to shock waves in air, which produce a pressure wave in the 'receptor' charge on striking it. Such shock waves are much stronger in the direction in which the detonation has been propagating"

More detailed explanation of the phenomenon of sympathetic detonation is given by Robinson in Ref 10b, p 16 and by Rinkensbach in Ref 13, p 67. Accdg to them:

"The detonation wave originating in the 'donor' moves at the velocity of several thousand meters per minute until it reaches the end of the chge and starts to penetrate the surrounding medium, such as air, thus creating a pressure wave. Its velocity at the beginning of travel thru the air is the same as inside the donor, but it rapidly diminishes since there is no more explosive

to feed on and since the wave dissipates in all directions (unless both the donor and the receptor are confined in a narrow pipe). However, if this wave should hit another mass of expl while it is still traveling at high velocity, it might have enough energy left in it to initiate deton in the new mass. The maximum distance (gap) depends on the rate at which the speed of deton wave decreases, which depends on its energy content and this, in turn, depends on the quantity and area of the donor. The greater the "strength" of donor and the greater its mass, the greater is the energy in the resulting wave and the greater is the gap

Deton may also be transmitted thru media other than air, such as water, earth, wood, glass, paper, cardboard, concrete or metal, but the gap will be much smaller. This diminution is very significant when small chges are involved

If the chges are unconfined the detonating wave of donor moves out in all directions, its energy presumably decreasing as its spherical volume increases. Since the vol of a sphere is proportional to the cube of the radius, it was assumed that the weight (W) needed to initiate sympathetic deton would vary as the cube of the distance (L). In other words, the relation W/L^3 could be assumed to be constant (See also Blast Effects in Air, Earth and Water in Vol 2 of Encycl, pp B180 to B184)

In actual practice, however, the equation $W/L^3 = k$ does hold as good as the equation $W/L^{2.25} = k$, proposed by F.A. Olsen. The constant k is different for each combination of expls. The fact that the relation W/L^3 does not fit experimental results, indicates that the sympathetic deton phenomenon depends not only on the weight but also on other factors. These factors might include "strength" (as mentioned before), detonation velocity, density of charge, sensitivity of receptor, etc

In order to apply the $W/L^{2.25} = k$ equation to practice, it is required to calc the constant k, but before this it is necessary to det L experimentally (by one of the "gap tests" listed below) for several weights (W)

and then calc $L^{2.25}$

For example, two expls A & B are listed in Refs 10a & 13, without giving their comps. After detg L's in feet for several W's in pounds, the values $L^{2.25}$ and $W/L^{2.25} = k$ were calcd and the results are given in table

Table I
Explosive A

| W | L | $L^{2.25}$ | $W/L^{2.25}$ |
|------|------|------------|--------------|
| 25 | 2 | 4.76 | 5.3 |
| 50 | 3 | 12 | 4.2 |
| 100 | 4 | 22.6 | 4.4 |
| 200 | 6 | 53.2 | 3.8 |
| 400 | 8 | 107 | 3.7 |
| 800 | 10.5 | 200 | 4.0 |
| 1600 | 14 | 380 | 4.2 |
| 2400 | 15 | 609 | 3.9 |

Average $k=4$

Table II
Explosive B

| | | | |
|-----|------|------|------|
| 25 | 9.5 | 158 | 0.16 |
| 50 | 13.5 | 348 | 0.14 |
| 100 | 19 | 750 | 0.13 |
| 200 | 21 | 940 | 0.21 |
| 400 | 26 | 1520 | 0.26 |

Average $k=0.18$

Suppose now that it is required to calc L for deton of 100000 lbs of expl A? From the equation $100000/L^{2.25} = 4$ is derived $L^{2.25} = 100000/4 = 25000$, which gives for $L = 90$ feet

Similarly, L equal to 122 feet for $W = 200000$ lbs was calcd

Baum et al (Ref 23, pp 766-67) and also Andreev & Belyaev (Ref 24, p 366) give the following equation:

$$R_{50} = KC^n$$

where R_{50} is distance in meters at which 50% of detonations take place, C = wt of donor in kg, $n=0.5$ for C's below 1000 kg, and K a constant calcd after R_{50} is detd experimentally for several C's. For example, if donor is phlegmatized RDX at density 1.25 and receptor TNT at d 1.35 and deton is conducted in open air, K is equal to 0.38. For other combinations the values of K are:

Table III

| | | |
|-----------------------|----------|--------|
| Tetryl (d 1.25) to PA | (d 1.0) | - 0.54 |
| TNT (d 1.25) " PA | (d 1.0) | - 0.33 |
| PA (d 1.25) " TNT | (d 1.0) | - 0.30 |
| PA (d 1.25) " PA | (d 1.35) | - 0.40 |
| PA (d 1.25) " Tetryl | (d 1.35) | - 0.50 |

The value of $n=0.5$ of the above equation holds only for weights, C , of donor below 1000 kg, whereas above it, n should be betw 0.33 and 0.5

B.I. Shekhter has shown that, if in deton the chges are placed in an acetyl-cellulose tube with walls 0.15 mm thick, the maximum distance increased by 40-50% (Ref 23, p 766)

In the section on detonation by influence in condensed media (Ref 23, pp 771-78), it is reported that E. Burlot conducted in France experiments with 50 g charges of PA (Mélinite) loaded at density 1.25 in cardboard cartridges of 28 mm diam. When donor and receptor were separated by air, the distance at 50% explns was 28 cm, whereas for water it was only 4 cm; for clay 2.5, sand 1.5, fir tree 3.5 to 4 and steel 1.5 cm

Shekhter et al detd in Russia (Ref 23, pp 774-78) deton thru various media from a 35.5 chge of phlegmatized (with 6% wax) RDX loaded at d 1.60 in 23.2 mm diam cartridges to cartridges of TNT at d's 1.30 to 1.60. They found that in propagation thru steel barriers the following delays in initiation of receptor were observed:

Table IV

| Density of TNT receptor | Thickness of steel, mm | Delay of deton, μ secs |
|-------------------------|------------------------|----------------------------|
| 1.30 | 12.0 | 2.1 |
| 1.30 | 14.0 | 3.3 |
| 1.30 | 16.0 | No deton |
| 1.50 | 12.0 | 1.4 |
| 1.50 | 16.0 | No deton |
| 1.60 | 12.0 | 1.4 |
| 1.60 | 14.0 | 2.0 |
| 1.60 | 16.0 | No deton |

The same investigators (Ref 23, p 776) detd delays caused by barriers of water when using different donors and receptors (Table V)

Cook (Ref 18, p 196) gives the following equation:

$$S_c^3 = kM$$

where S_c is limiting distance, k =constant different for each expl and M =wt of donor (called primer in ref). This equation will apply only if one uses a donor of fixed L/d (where L is the length and d the diameter), and k will be a maximum for any expl of fixed compn, density, and granulation for L/d 1.0. Also, above equation may be upset if there is a chance for the expl to hurl solid fragments, because they can set off an expl over far greater distances via the hot-spot mechanism than the blast wave itself. In addn, k will depend upon how one expresses sensitiveness results. There are three ways to do it: a) Maximum distance for 100% consistent detons by influence; b) Maximum distance for 50% detons and c) Minimum distance for consistent failures (0% detons). It is usually best to adopt the 50% gap for defining k , since it can be more accurately established (Ref 18, p 196) (See also Ref 23, p 764-66)

Table V

| Donor & Density | Receptor & density | Thickness of barrier, mm | Delay in microsecs |
|----------------------------|----------------------------|--------------------------|--------------------|
| Phlegmatized RDX at d 1.60 | PETN at d 1.65 | 20 | 2.0 |
| | | 25 | 2.5 |
| | | 30 | 3.0 |
| | | 35 | No deton |
| TNT at d 1.61 | PETN at d 1.65 | 20 | 2.5 |
| | | 25 | 4.5 |
| | | 30 | No deton |
| Phlegmatized RDX at d 1.60 | Phlegmatized RDX at d 1.60 | 23 | 3.3 |
| | | 25 | No deton |
| TNT at d 1.60 | TNT at d 1.30 | 20 | 2.5 |
| | | 25 | 5.0 |
| | | 25 | No deton |

Air-gap test, commonly known as *gap test*, has great practical value in both military and commercial expls. In explosives plants and storage magazines (both military and commercial), it indicates what minimum distances should be observed in order to protect the buildings and expls (or ammunition) contained in them. The distances for

various quantities of expls are in the tables of various US Ordnance Manuals, such as listed as Refs 10b and 12a or later editions (See also Intraline Distances, Vol 2 of Encycl, p B358-L under Burning Ground and Destruction Site; also Burning of Ammunition and Explosives, p B358-R, Vol 2 and Decomposition, Destruction, Disposal of Ammunition, Explosives and Pyrotechnic Compositions in Vol 3, p D23-L to D35-R)

The sensitivity to initiation tests, such as gap tests, provide in mining a measure of probable borehole performance, i.e. whether or not the expl may be depended upon to propagate in a long column under the confinement of the borehole. Experience has shown that in order to ensure satisfactory borehole performance, the explosives should meet the requirements of some of the tests listed below

These tests serve also for determination of how much shock can be tolerated for safe handling of any explosive during storage or transportation

As has been mentioned already, the sensitiveness to influence is lower when media other than air are used. There are tests specially designed for using wax as a barrier, such as the *wax-gap test* of Spencer Chem Co described in Vol 1 of Encycl, p A354, footnote c and the *booster sensitivity test* described in Vol 1, p VIII

Other methods for detg sympathetic detons include:
Booster-Gap Explosive Sensitivity Test of Cole & Edwards, described in detail in USP 2832213 (1958) (Ref 17). It was claimed to be more reliable and less expensive than the *card test* (See after "card-gap test") and the *three-legged table test*, described here after "shock-pass-heat-filter test". The "booster-gap test" serves for evaluating shock sensitivity of liquid explosives. It includes a set of snug-fitting telescopic cardboard tubes (ca 1 inch diam) and a cylindrical wooden block for holding the electric blasting cap, Tetryl booster pellet, circular spacer cards, and the cup with liquid explosive (to test) fit compactly in the cardboard tubes when

assembled; the entire assembly being supported by a metal pedestal. The spacer cards, which are made from cellulose acetate film 0.010 inch thick, serve to build-up a gap between the Tetryl pellet and the bottom of the cup contg liquid explosive. A steel plate ca 3/8 inch thick is used to cover the cup. The cup for noncorrosive liquids is made from galvanized 1-inch welded steel pipe 3 inches in length with a brass disk 0.0015-inch thick attached at the bottom. For corrosive liquids, the pipe is coated inside with Teflon and the bottom is Teflon tape 0.003-inch thick. It has been found that a Teflon bottom attenuates the booster shock somewhat less than does brass. The sensitivity value for a given liquid explosive is taken as the number of 10 mil cellulose acetate spacer cards required for a gap at which the liquid explosive detonates in 50% of the test shots

Booster Sensitivity Test is briefly described in Vol 1 of Encycl, p VIII

Card-Gap Sensitivity Test of Cook et al. In this test the confined acceptor charge is separated from the Tetryl donor by a stack of plexiglas cards, the number of which is a measure of the gap thickness. The thickness at which 50% of the trials result in initiation and propagation of detonation in the acceptor is determined. Evidence of such is obtained with a pressure transducer and continuous rate measuring probe, supplemented by observations of the damage to the container and the steel witness plate (See also "Liquid Propellant Information Agency, Card-Gap Test for Shock Sensitivity of Liquid Monopropellants", Test No 1 in Liquid Propellant Test Methods, Silver Spring, Maryland, March 1960). The sensitivities of a number of liquid explosives to both low-velocity and high-velocity detonation were determined by Hay et al of the Pittsburgh Station, USBurMines, pp 412-25 of Ref 28, using a modification of card-gap test

Card Test. This is an expl test device used to establish the shock tolerance limit. It employs heavy cords attached to the floor & ceiling of a firing chamber to suspend a board which supports a cup contg liq expl (to test), a Tetryl pellet, cap holder & spacer cards held snug against the bottom of cup by elastic bands. Although serving the purpose, this suspension setup proved expensive & excessively time consuming (Ref 17)

Coefficient de self-excitation (CSE). French test, described in Vol 3, p C390-L

Four-Cartridge Test (Ref 16a, p 52). The test, designed in Germany under the name "Detonationsfähigkeit Probe", was conducted as follows:

Four cartridges, 35 mm in diam, were laid end to end on a bed of sand and one end of the train was detonated by a No 3 Blasting Cap. To pass the test, it was required that all four cartridges be detonated completely

Gap Tests. See Vol 1 of Encycl, p XIV

Halved-Cartridge Gap Method. See Vol 1 of this Encycl, p XIV, under Gap Test and Ref 18, p 194-R

Shock-Pass-Heat-Filter (SPHF) Sensitivity Test. Cook et al (Ref 18, pp 83-9 & 187-94 and Ref 27) consider that a "heat wave", along with the shock wave, is a requisite for the propagation of detonation. A "shock-pass-heat-filter", which is a thin glass plate, placed perpendicular to the axis of the charge and extending beyond its surface, interrupts the heat wave but lets the shock wave continue until detonation can be re-established beyond the "barrier" after the usual induction period. From a donor charge the shock starts thru the barrier (such as SPHF) into the receptor, either liquid or solid, as an initially nonreactive shock, which either dies out or starts reaction in the receptor as a deflagration which may develop into a detonation if the shock is

strong enough. By working within the sensitivity, i.e. the maximum plate thickness from which the transition to detonation can occur, it is possible to study the DDT (Detonation from Deflagration Transition) in considerable detail (Ref 29)

Three-Legged Table Sensitivity Test. This test device, later than the card test, employs a three-legged table having a top & shelf, a Tetryl pellet resting on the shelf and supporting the spacer cards & cup, the cup being passed thru a close-fitting opening in the top and the cap holder being extended thru a hole drilled in the shelf. This device has the advantage that the several parts are few, simple, inexpensive, and their assembly for firing is easy, requiring less time than the Card Test (Ref 17)

Wax Gap Test. See Vol 1 of Encycl, p VIII under "Booster Sensitivity Test" and under Ammonium Nitrate, p A354, Note c

Whole-Cartridge Sensitivity Test. It is a gap test in which two whole cartridges, 1-1/4 x 8 inches, are wrapped in paper with a gap of distance δ between the end crimps of the original shell which face each other across the air gap (Ref 18, p 194-R). Compare with the test described in Ref 13, p 68 in Vol 1 of Encycl, p XIV under "Gap Test". See also "Halved-Cartridge Gap Method"

Refs: 1) L. Lheure, MP 13, 161-203 (1905-1906) (Étude des effet à distance des explosions); Ibid, SS 2, 228-30, 249-52, 308-12, 427-29 & 446-50 (1907) (Ueber Explosionsfernwirkungen) 2) A.M. Comey, 7th Internl Congr Appl Chem, London (1909), Sectn IIIb, p 28 (Testing sympathetic deton) 2a) Marshall 2 (1917), 430 3) E. Kayser, SS 16, 9-10, 25-7 & 35-7 (1921) (Detonationsübertragung brisanter Sprengstoffe) 4) Anon, Army Ordn 3, 180-82 (1922) (Sympathetic deton tests of HE shells) 5) C.G. Storm, Army Ordn 3, 256-60 (1923) (Sympathetic detons) 6) G. St. Perrott & D.B. Gawthrop, JFranklInst 203, 103 & 387-406 (1927) (Propagation of deton betw two cart-

ridges of explosive) 7) E. Burlot, MAF 9, 799-960 (1930) & CA 25, 55-63 (1931) (Détonation par influence) 8) K.K. Andreev, GornyiZhur 15, No 2, 55-8 (1932) & CA 27, 5979 (1933) (A detonating cap was placed in a lead cylinder and axially under this, and at definite distance, a 2nd cap was fixed. When the 1st cap exploded the deton wave traveled thru the air to the 2nd cap whose expln made an impression in the Pb cylinder. By changing the distance betw the caps, a value for the sensitiveness to propagation of deton was obtd) 9) D.B. Gawthrop, JFranklInst 214, 647 (1932) (Deton by influence) 10) R.L. Clark, IEC 25, 663-67 (1933) (Deton by influence) 10a) N.A. Tolch, "Law of Similitude for Sympathetic Detonation", BRL Rept 385 (1943) 10b) Robinson (1944), 15-20 (Sympathetic deton) 10c) Anon, "Ammunition Inspection Guide", WarDeptTechManual, TM 9-1910 (1944), 799 (Sympathetic deton) 11) R.H. Stresau & L.E. Starr Jr, "Some Studies of Propagation of Detonation Between Small Confined Explosive Charges", NOLM 10577 (1950) 12) C.M. Mason et al, "The Physics and Chemistry of Explosive Phenomena", USBurMines, Pittsburgh, Pa, ProgrRept Oct-Dec 1950; Contract NA onr 29-42, Project NR 053 047 [In the course of tests for detn of temp of deton by radiation method, observations were made on the propagation of the deton wave thru various thicknesses of the non-expl substances, of density ca 1.9, placed betw expl pellets:

| Expl | Non-expl Substance | Layer Thickness, mm | Propagation | Non-Propagation |
|--------|--------------------|---------------------|-------------|-----------------|
| PETN | NaCl | 16 | x | - |
| PETN | NaCl | 20 | - | x |
| PETN | Graphite | 16 | x | - |
| PETN | Graphite | 21 | - | x |
| PETN | Al | 12 | x | - |
| PETN | Al | 26 | - | x |
| Tetryl | NaCl | 16 | x | - |
| Tetryl | Graphite | 15 | - | x |
| TNT | NaCl | 16 | - | x |
| TNT | Graphite | 15 | - | x |

Propagation of deton was indicated by the initiation of the expl pellet placed below the non-expl substance. Tests reported as non-propagating indicate that the lower expl pellet was not completely reacted as shown by a powder residue after deton]

Note: These non-explosive layers are known as *barriers*

12a) M. Sultanoff & R.A. Bailey, "Induction Time to Sympathetic High Order Detonation in an Explosive Receptor Induced by Explosive Air Shock", BRL Rept No 865 (1953) 13) Anon, "Military Explosives", TM 9-190 (1955), 67 (Detonation by influence) 14) A. Haid, Explosivstoffe 1955, 139-44; PicArnsnTranslation No 5 (1956) by G.H. Loehr (Deton by influence) 14a) J. Savitt, "Investigation of Sympathetic Detonation and Evaluation of Structures for Ammunition Manufacture", Final Rept, ArmourRes-FoundationCenter, 20 Oct 1955 (Contract DA-11-173-ORD-416) 15) T. Watanaba & O. Murata, JIndExplSocJapan 17, 102-11 (1956) & CA 50, 17454 (1956) (Deton by influence) 16) G.R. McVey & V.M. Boyle, "Sympathetic Detonation in Composition B Induced by Air Shock from Pentolite and from Composition B", BRL Rept 1048 (1956) 16a) PATR 2510 (1958), p Ger 52 (Four-cartridge test) 17) J.B. Cole, G.D. Edwards & T.K. Rice, USP 2832213 (1958) (Booster-gap explosive sensitivity test claimed to give more reliable results than the "card" and "three-legged table" tests) 18) Cook (1958), 189-90 (Designation of "donor" & "receptor" and "shock-pass-heat-filter" method); 194-97 (Deton by influence - testing by air-gap method and a brief discussion on testing thru gap filled with water, mud or solids; some theoretical discussion on deton by influence); 330-31 (Sympathetic deton underwater); 332 [Table 13.6 giving average air-gap initiation induction time data taken from BRL Rept 865 (1953) of M. Sultanoff & R.A. Bailey and the shock velocity V^* computed by M.A. Cook] 19) M.A. Cook et al, PrRoySoc 246A, 281-83 (1958) (Deflagration to detonation transmission in solid and liquid expls) 20) R.J. Eichelberger

- & M. Sultanoff, *PrRoySoc* **246A**, 274-81 (1958) (Sympathetic deton and initiation by impact) 21) Dunkle's Syllabus (1957-1958), p 152 (Some work conducted at BRL on sympathetic deton is briefly discussed) 22) M.A. Cook et al, *JApplPhys* **30**, 1579-84 (1959) (Instrumented Card-Gap or SPHF-Plate Test) 23) Baum, Stanyukovich & Shekhter (1959), 754-71 (Deton by influence thru air); 771-78 (Deton by influence thru condensed media); 778-81 (Safe distances for propagation of deton betw some expl chges used in Rus coal mines) 23a) Liquid Propellants Info Agency, Applied Physics Lab, Johns Hopkins Univ, "Liquid Propellants Test Methods, Test No 1, Card-Gap Test for Shock Sensitivity of Liquid Monopropellants" (March 1960) 24) Andreev & Belyaev (1960), 365-67 (Calc and exptl detn of distances "safe" to deton by influence thru air) 25) M. Sultanoff et al, "Shock Induced Sympathetic Detonations in Solid Explosives", pp 520-32 in Vol 2 of the 3rdONRSympDeton (1960) 25a) M.A. Cook et al, *TrFaradSoc* **56**, 1028-38 (1960) (Promotion of shock initiation by metallic surfaces) 26) Dunkle's Syllabus (1960-1961), p 13a, 2nd paragraph (Discussion on the work of Eichelberger & Sultanoff on sympathetic detonation, listed here as Ref 20); p 13a, last paragraph [Discussion on the works of Cook et al on sympathetic detons, listed here as Ref 19. They called the barrier betw "donor" and "receptor" a "shock-pass-heat-filter" (SPHF) and attributed the degradation of the process by the barrier to absorption of heat despite transmission of the shock. The shock starts into receptor, either liquid or solid, as an initially nonreactive supported shock, but transforms to a detonation when overtaken by a chemical reaction]; p 14f, last paragraph (Discussion on the work of Cook et al, listed here as Ref 25) 27) M.A. Cook et al, 7thSympCombustn (1959), pp 820-36 (Shock-pass-heat-filter test) 27a) A.Ya. Apin et al, *DoklAkadNauk* **147**, 1141-43 (1962) & *CA* **58**, 7780 (1963) (Transmission of detonation at a distance-sympathetic detonation; RDX, PETN, Tetryl & PA were tested as 60-mm long receptor chges with 50/50 Cyclotol as donor in 20-mm diam cartridges) 27b) L. Deffert et al, *CombustFlame* **8**(2), 105-11 (1964) & *CA* **61**, 13118 (1964) [Transmission of detonation for exchanged ions expls (EIE) is not as good under confinement as it is in open air, whereas classical safety expls transmit deton to a distance which is proportional to the degree of confinement. An EIE is relatively insensitive to a shock wave but very sensitive to impact of particles. This is attributed to the fact that these expls contain some nongelatinized NG & Nitroglycol, the initiation of which occurs accdng to a thermal process] 28) J.E. Hay et al, 4thONRSympDeton (1965), pp 412-25 (Modification of Card-Gap Test) 28a) R.H.F. Stresau, "Size Factors in Detonation Transfer", 4thONRSympDeton (1965), 442-48 28b) K. Sakamoto & H. Yoshitomi, *KogyoKagakuKyokaiishi* **27**(6), 377-81 (1966) & *CA* **66**, 10932 (1967) [Large-scale gap tests were carried out underwater with Ammonia Dynamite as donor and 150 g of the following expls as receptor: Ammonia Dynamite, Gelignite, NG, Blasting Gelatin, PETN, Guncotton, Black Carlit (AP 66-70, FeSi 8-12, woodmeal 15-19 & heavy oil 3-7%), Permissible Powderly Dynamite, BlkPdr, TNT & AN-FO] 28c) B.N. Kubib, *VzryvnoeDelo* **1966**(60/17), 63-68 & *CA* **67**, 1295 (1967) [Detonation capacity of mixts contg 5-15% NG & inert fillers (NH₄)₂SO₄, NH₄Cl, NaCl & sand was characterized by detn of critical diameters. Other tests were made by detn of the sensitivity of the mixts to detonation transfer. The cartridges were hung in air one above the other; the active cartridge was 100 g of a mixt of AN (85%) & NG (15%); the passive cartridge consisted of NG (15%) & inert salt (85%)]. *Ibid*, 83-96 [The critical diam of deton and the max gap distance for sympathetic detonation in test expls (NG, DEGDN, HMX & PETN) were used as criteria of sensitization on inert filler NaCl, (NH₄)₂SO₄ & NH₄Cl. Combinations of solid & liq sensitizers are recommended] 28d) R.L. Grant et al, *USBurMines*, *RI* **6947**

(1967), 17pp [Two new gap-sensitivity methods are described for measuring the ability of permissible expls to propagate across a gap. The two methods use full, instead of half cartridges, an air gap in one and a coal dust gap in the other, and rigid paper tubes to contain the cartridges better] 29) Dunkle, private communication, January 1968

Section 7
Detonation (and Explosion), Initiation (Birth), and Propagation (Growth or Spread) in Explosive Substances.

Accdg to Kistiakowsky (Ref 12, p 959), expls can be brought to detonation by various means, all of which involve either heating or mechanical impact or combinations of both. The ease with which deton is started varies greatly from one expl to another, and this offers a means of differentiating expls accdg to their sensitivity

The first effect of application of heat to unconfined expls is a thermal decomposition which changes into a luminous deflagration when the local temperature of the explosive is permitted to rise further. In some initiating (primary) HE's (such as MF) the deflgrn changes quickly into deton, while with LA there seems to be no deflgrn but only deton. In secondary HE's the deflgrn may continue until the entire charge is consumed or it may also change into detonation. The transition is facilitated by confinement, by finer subdivision (which increases the surface area of expl grains), and by increasing the mass of the expl chge

Any form of mechanical action (such as impact, friction, etc) can cause a deton if the expl is sensitive to this action. Earlier discussions of the "mechanical sensitivity" of expls made use of an assumed special ability of expls to deton under mechanical stimulus alone. Recent work, particularly the experiments of Bowden et al [Refs 13, 14a & 27 and also Refs 4, 5, 8 & 9 under Birth (Initiating) and Growth of Detonation, etc in Vol 2 of Encycl, p B127-L], have shown that a mechanical impact causes the

deton of expls thru the primary mechanism of rapid heating. Dunkle considers that, essentially, as the "pressure jump". The heating is largely caused by friction betw solid grains and by adiabatic compression of gases in the interstices betw the grains. The immediate consequence of the heating is deflgrn, which changes very rapidly into the deton only because of the extremely strong confinement presented by the impacting solid surfaces. It has been suggested that mechanical shock waves which may be formed within the mass of a granular expl by the hot product gases streaming from the site of a deflgrn, are the immediate cause of deton wave (Ref 13)

Accdg to Cook (Ref 32b, p 172), the initiation of deton is fundamentally a heat-balance problem which may be expressed by the following simplified equation:

$$H = F + G$$

where H = chemical energy generated by the decompn of the expl

F = heat loss and

G = accumulation of heat in the expl

With an increase of temp, H increases in an exponential manner, but F increases, in general, at a much lower rate. As the temp increases, G becomes more and more important and an increase in G causes further increase in H, and the reaction tends to accelerate in all expls by virtue of their exothermicity. This factor is fundamental in all explosions, irrespective of the mode of initiation. As a further result of their exothermic nature and their generation of gaseous products, expl decompns create pressure gradients the magnitude of which depends on the reaction rate. When sufficiently large, these gradients can produce propagating pressure pulses and eventually, for still higher reaction rates, intense shock waves. These waves remove energy from the region of reaction and convey it away at the velocity of sound. They tend, however, to decay rapidly unless continually reinforced. Deton occurs when temps in the shock wave become so high that an appreciable portion of the heat of reaction is released in the

shock wave itself before the shock is eaten away by the rarefactions which follow. Although any shock of appreciable intensity can cause reaction to occur, only those shocks in which the temp is high enough to decompose an appreciable fraction of the expl within a few millimeters of the shock front can become deton shocks. On the other hand, some shocks causing considerable chemical reactions may die out completely

Knowledge of the conditions for initiation of deton (or expln) is of great practical importance both from the viewpoint of causing deton to occur when it is wanted, and also to prevent it from occurring when it is not wanted, e.g. during manuf, storage, shipment, and handling in prepn for use. This problem has received a great deal of consideration, and many methods have been designed for its study. These include, among others, the following tests: heat sensitivity (such as explosion temperature, spark & other forms of electrical discharge), impact (drop, bullet), friction (BurMines method, German method), by influence (or sympathetic detonation) - thru air or condensed area, and by detonators & boosters of various types (Ref 32b, p 172). Atomic expls are initiated by special devices, which are still classified

Mason et al (Addnl Ref B), conducted at US Bureau of Mines a series of investigations and issued several progress reports. As no summary report was issued, we give here resumés of each progr rept. Progress Rept April-June 1949. In order to study the effects of variables, such as mass, density, particle size, degree of confinement, prior heat treatment, presence of impurities, and other factors upon the sensitivity of expls to thermal initiation, the delay to ignition at a const temp has been selected as a criterion of sensitivity because of its significance and because it can be measured accurately. For the measurement of delay in ignition, an apparatus consisting of an electrically-heated cylindrical bath contg molten Wood's metal controlled with a Variac to within $\pm 0.5^\circ$ is used. A copper detonator shell contg a small amt of sample and closed with a

cap is half-immersed in vertical position in the bath and kept there until the cap blows off the top of the detonator. The delay to ignition is detd to a hundredth of a second with an electric timer which automatically starts when the detonator is immersed in the bath and automatically stops when the ignition takes place. Preliminary investigation on the effects of mass and particle size upon the delay to ignition of PETN showed that ignition time increased with increasing mass of the sample within the range tested, namely 1 to 20 mg, but effect of particle size appeared to be small. ProgrRept July-Sept 1949. Study of effect of mass on ignition time for chges of PETN betw 1 and 25 mg showed that the delay increased with the mass of the chge in a roughly linear manner, as shown in Table A

Table A

| Ignition temp °C | Mass, mg | Av ignition delay, sec |
|------------------|----------|------------------------|
| 250 | 1 | 1.17 |
| 250 | 10 | 1.36 |
| 250 | 20 | 1.51 |
| 250 | 25 | 1.66 |
| 275 | 1 | 0.52 |
| 275 | 10 | 0.62 |
| 275 | 20 | 0.83 |
| 275 | 25 | 0.90 |

Study of the effect of particle size on ignition time indicates that the effect, if any, is very small

Study of the effect of diluting PETN with an inert solid showed that when sand (30-mesh) was used, the ignition time apparently depended only on the mass of sample (PETN + sand) and not upon the percentage of PETN or sand. Dilution with zinc, however, had the effect of decreasing the ignition time. For example, 100% PETN charge had ignition time 1.61 sec at 250°, while the 50/50-TNT/Zn sample ignited in 1.24 sec

Study of the effect of preheating a 10 mg sample of PETN on the subsequent ignition delay is shown in Table B

Table B

| Ignition temp °C | Ignition delay, secs | | |
|------------------|----------------------|------|------|
| | I | II | III |
| 237.5 | 2.09 | 2.75 | 1.54 |
| 250.0 | 1.36 | 1.74 | 0.87 |
| 275.0 | 0.62 | 0.78 | 0.49 |
| 300 | 0.36 | 0.38 | 0.28 |

Here I signifies untreated PETN; II - PETN which had been preheated at 150° during 5 to 60 secs and then allowed to slowly cool to RT; III - PETN treated as in II, then heated at 250° for ca 1 sec and allowed to stand 1 hr to 2 days. These samples were partly decompd because their mp was 130-135° vs 141.5-142° for untreated PETN which is the reason they ignited in shorter time. Extraction with hot water of samples III removed the impurities and raised the mp of chge to 140°, thus increasing their ignition times to values of untreated PETN. The increase in ignition time caused by prior heating at 150° (sample II) is probably due to the large decrease in the surface area of the material when the melt solidified by slow cooling
 ProgrRept, Oct-Dec 1949. To obtain further info about influence of prior heat treatment on ignition delay samples of PETN, preheated at 150° during 5 secs were either reheated for 3 hrs at 90° or stored for 1.5 hrs at 23° & 1 mm pressure. The delay to ignition time of these samples was then detd and it was observed that neither treatment had changed the sensitivity of preheated PETN. Other tests included the effect of mass on ignition time at 250° of NC (13.15% N) and on Cordite N (modified) (See Table C)

Table C

| Substance | Mass, mg | Delay, secs |
|-----------|----------|-------------|
| NC | 5 | 2.40 |
| NC | 10 | 2.90 |
| NC | 20 | 3.08 |
| Cordite | 11 | 5.9 |
| Cordite | 21 | 10.8 |

and the effect of preheating to 250° for 1.5-3.0 secs, prior to reheating at 250° (See Table D)

Table D

| Substance | Ignition Delay at 250° in secs |
|---------------------------------|--------------------------------|
| NC, not preheated | 2.84 |
| NC, preheated for 1.5 secs | 2.24 |
| Cordite, not preheated | 5.8 |
| Cordite, preheated for 1.5 secs | 4.8 |
| Cordite, preheated for 3 secs | 4.9 |

Gibson et al conducted at BurMines beginning in 1959 a series of tests and issued several progress reports, followed by a Summary Rept published in 1962 (Ref 38e). Accdg to investigations described in that rept, initiation delays in several single compound expls varied over a considerable range, although initiated from identical sources. The delay order ranked with the basic sensitivity of the expls, e.g., PETN had 5 microseconds delay, RDX 10 & Tetryl 15. For the same stimulus TNT failed to be initiated. Indeed this may be a criterion for explosive and/or proplnt sensitivity evaluation

Andersen & Chaiken (Ref 38b) suggested that the shock wave initiates a self-supporting chem reaction at the oxidizer grain surface by compressional heating and that the delay time from the moment of the shock passage may be the controlling factor in detg the detonability of composite proplnts. However, they further stated that the initiation delay is probably related to the concentration, porosity and oxidizer distribution, additives, and the strength of the initiating shock wave. It then appears that the use of the pressure and the ionization probes, substantiated by photographic methods, could produce a quantitative method to det the deton induction times and thus rank the sensitivity of new formulations as well as existing proplnts & expls

A charge of high-performance, double-

base (HPDB) type proplnt, 29 mm in diam, readily detonated when confined in a steel container and subjected to direct shock initiation by a 14 g Tetryl booster. The resulting steady-state velocity was ca 7.5 mm/microsec, which is essentially that of NG. It was found, however, that confinement is not necessary to sustain deton in the HPDB proplnt, but velocity of unconfined chges is lower (6.5 instead 7.5 mm/microsec). When using a conical (pyramidal) chge, as shown in Fig 13 of the Rept and reproduced here as Fig 1 (without oscillogram), the deton ceased at a point where diam of 4 mm was reached (as indicated by arrow)

Although the conical (pyramidal) type strand offers an approximation of a critical diameter, a less ambiguous method involves the use of strands having cylindrical segments of diminishing diam toward the downstream end.

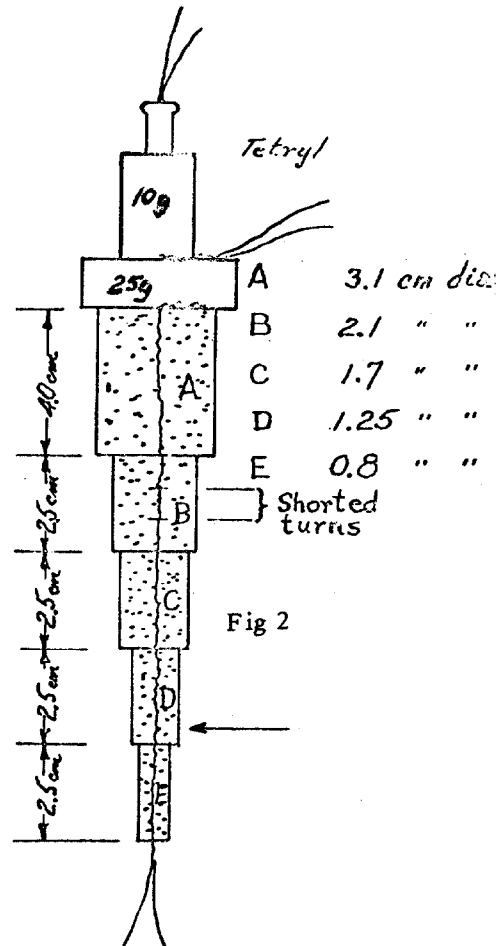
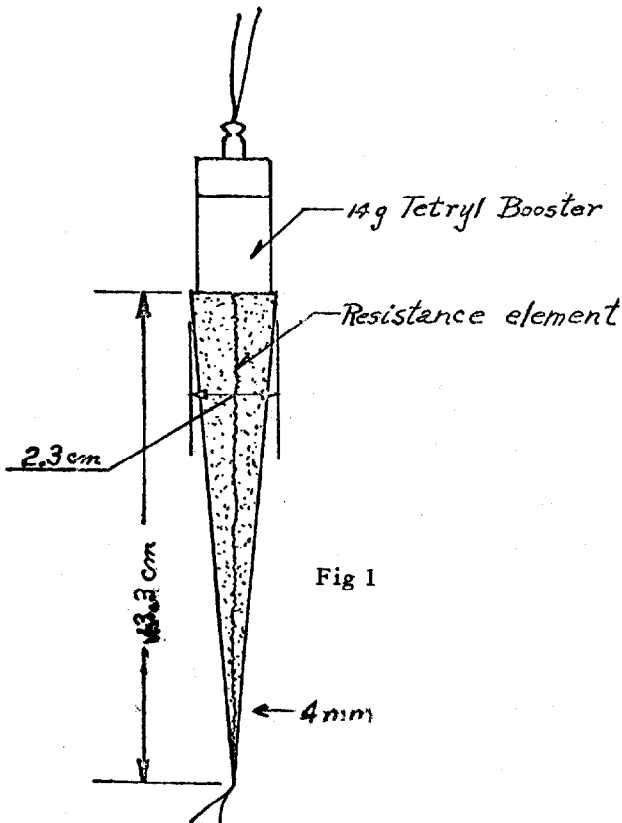

HPDB proplnt, deton ceased in the 1.25 cm diam segment (as indicated by arrow) but readily propagated thruout the next larger segment of 1.7 cm. Two typical resistance element records are shown in Figs 14 and 15 of the Rept. Fig 14 is reproduced here as Fig 2 without oscillogram. The steady-state rate was 6.5 mm/microsec

In the chge represented in the report as Fig 15 and here as Fig 3 (without oscillogram), deton ceased in the 1.25 cm segment of HPDB proplnt. The steady-state velocity was ca 6.5 mm/microsec that decayed to ca 5 mm/microsec as the deton approached diam discontinuity

These results indicated that the HPDB proplnt can readily detonate in its manufd form when initiated by an expl stimulus of sufficient magnitude. However, tests conducted to simulate a runaway reaction from

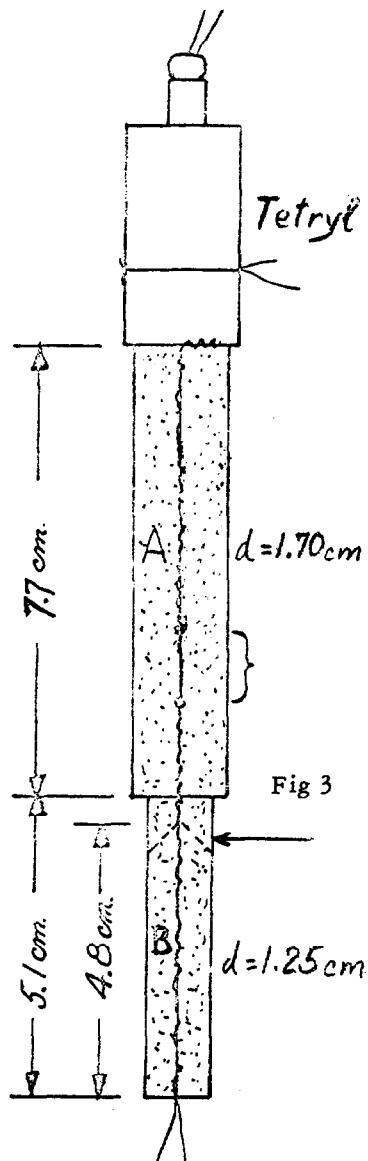

mild thermal initiation never resulted in deton. The most severe tests of this type were conducted in closed vessels of self-sealing type shown in Fig 16a of the report and reproduced here as Fig 4a, together with clamping device, Fig 16b, reproduced here as Fig 4b

The relatively low pressures developed in the early burning stages expanded the thinned portion of the hollow concentric liner and provided a continuous seal as the pressure continued to rise. In order

to restrain axial separation of the assembly, a jig was used to clamp the vessel as shown in Fig 16b. The vessel ruptured during the test when the pressure was in excess of an estimated 100000 psi, with very little erosion of the interior surfaces or wire lead holes, and most of the proplnt was recovered as small pieces

Many hypotheses for initiation of liquid expls have been proposed, of which Bowden et al (Refs 13, 14a & 27) suggested adiabatic compression of gas bubbles; Johansson et al (Ref 28) - vapor or droplet burning; Andreev (Ref 29) - droplet formation or suspension behind a burning front is capable of causing a transition to detonation; Bolkhovitinov (Ref 33a) - crystallization of the material under pressure; Cook et al (Ref 34b) - initiation occurs with the development of a pressure-generated metallic state accompanied by a plasma that provides the postulated requirement of high heat conductivity

Observations of initiation were conducted at the BurMines using a high-speed framing camera. The procedure was the same as described here in the section "Detonation (and Explosion), Development (Transition) from Burning (Combustion or Deflagration. Drawing of a test vessel used for initiation and growth studies in liquid expls is in Fig 18 of the report

As result of the research at BurMines, a mechanism for initiation under "card-gap" conditions was suggested and the alternate explanation for the off-the-charge-end "plasma" phenomenon reported by Cook et al (Ref 34b, pp 1881-92) was provided. The "off-end" phenomenon is briefly described in Ref 38f. A theory of initiation of liquid expls formulated at the BurMines is described in this section under Cavitation Phenomenon

The initiation delay has been also measured for several solid expls when subjected to a relatively weak shock stimulus generated by an HE and attenuated by a rubber barrier. The delay was found to be dependent on the barrier thickness, at least for the geometry employed. For a zero gap

condition using Tetryl of $d=0.95$ g/cc there was no detectable delay; for a 10 mm barrier the delay was 2 microsecs and for a 26 mm barrier 16 to 20 microsecs. Corresponding values at 26 mm barrier were 12 microsec for RDX and 4 for PETN. TNT failed to detonate under these conditions. If

initiation delay is a measure of sensitivity, it would mean that PETN is the most sensitive, then RDX, Tetryl and finally TNT (See Figs 30 & 31 of the Rept)

Two parallel probes were used in initiation and growth to detonation of a granular expl; one was positioned on the axis and one

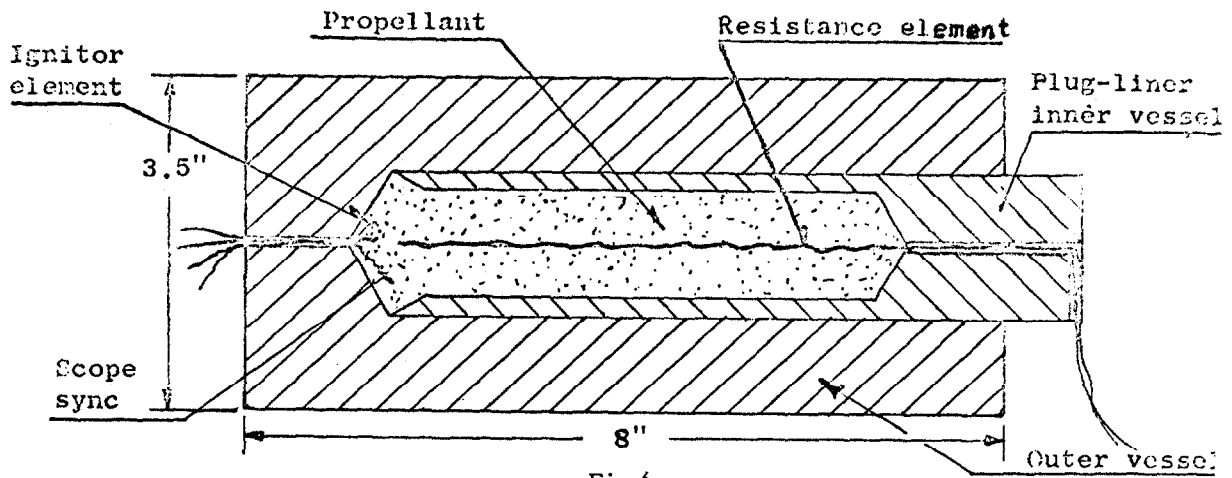

Self-sealing pressure vessel

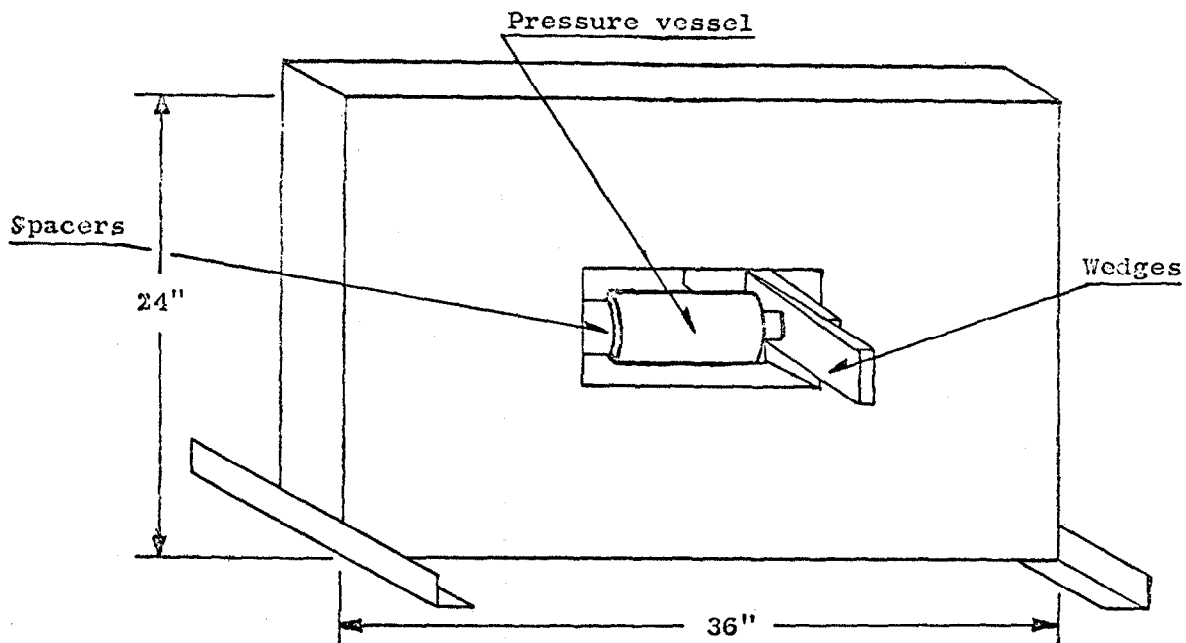

Clamping device with pressure vessel inserted

on the periphery of the chge. Initiation first occurred on the chge axis and ca 0.5 microsec later on the chge wall (See Fig 32 of the Rept)

A conical chge was employed to det the critical diam of granular TNT, confined only by a single layer of 0.010-inch cellulose acetate, for the purpose of comparing TNT with other materials investigated under a similar test condition. The deton propa-

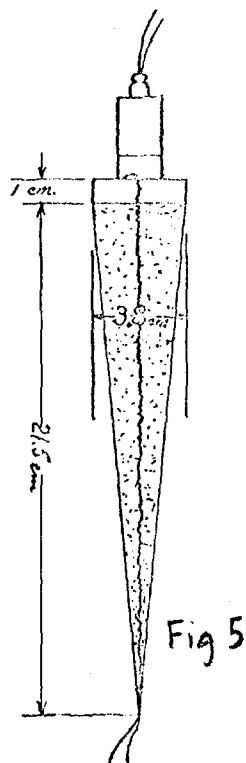

gated with velocity 2.9 mm/microsec from diam 3.6 cm to 1.0 cm and then dropped to 1.9 mm until it reached the critical diam of 0.56 cm where the deton ceased. Fig 33 of the report is reproduced here as Fig 5 (without oscillogram). The chge contained a resistance element

"Thermal Decomposition and Initiation of Explosives" is discussed briefly in Dunkle's Syllabus (Supplement) (Ref 37b, p 13.f), while a detailed description is given by H.R. Ubbelohde in Chap 11 of Garner's book (Ref 16c)

Dr B. Reitzner stated that the condi-

tions from a thermally steady state to a state that "runs away" are given by the Frank-Kamenetskii formulation. This formulation for spontaneous heating has been quantitatively expressed in a differential equation of which the solution is given in terms of a dimensionless constant. The value of this constant for the condition of spontaneous heating is equal to or exceeds 3.32:

$$\frac{r^2 n Q r B}{\lambda R T^2} = \delta \geq 3.32 \quad \text{or} \quad r_0 \geq \left(\frac{3.32 \lambda R T^2}{n Q r B} \right)^{1/2} \quad (1)$$

where: r_0 = critical radius for spontaneous heating, cm; λ = thermal conductivity, $(2.9 \text{ to } 3.9) \cdot 10^{-4} \text{ cal cm}^{-1} \text{ }^\circ\text{C}^{-1} \text{ sec}^{-1}$; R = gas constant, $1.987 \text{ cal }^\circ\text{C}^{-1} \text{ mole}^{-1}$; n = number of moles/cc ($10^{-2} \text{ mole cm}^{-3}$); Q = heat of reaction (14.4 kcal/mole at 170°C & 16.3 kcal/mole at 200°C); r = rate of reaction (moles decomposed per mole present per second); and B = activation energy for reaction (50 kcal/mole)

The critical radius r_0 is thus a function of the universal constants δ and R . Since r , which may change by a factor of 10^{10} over an important temperature range, is considered the only significant variable, eq 1 can be written as:

$$r_0 = C(r)^{-1/2} \quad (2)$$

where: C = a constant equal to $\sqrt{\lambda R T^2 / n Q B}$ (Ref 25, pp 137-38). See also Ref 48f

The Frank-Kamenetskii equation uses a simple Arrhenius relationship for the reaction rate. The Arrhenius equation can be written as:

$$r = A e^{-B/RT} \quad (3)$$

where: A = constant (proportional for monomolecular reactions to probability of breaking the molecules, while for bimolecular reactions A is proportional to the number of collisions per second); B = activation energy; expression $e^{-B/RT}$ characterizes the relative number of active molecules (Ref 25, p 138 & Ref 34a, p 77)

The equation (4) given below; shows that the logarithm of the critical radius, r_0 , is approx linearly related to the reciprocal of the absolute temperature of the environment:

$$\ln r_0 = C' + C''/T \quad (4)$$

where: $C' = \ln \left(\frac{\lambda RT^2 \delta}{nQBA} \right)^{1/2}$ and $C'' = \frac{B}{2R}$

with all symbols as defined under Eq (1)

It is further stated by Reitzner in Ref 37b, p 13f, that Arrhenius simplification does not take into account that a large number of expls follow an autocatalytic reaction mechanism. In the case of the inorganic azides, for example, the metal is considered to be the autocatalyst. The pressure-time curves for such autocatalytic reactions are characterized by an induction period, followed by acceleratory and decay periods. Since little or no heat is evolved during the induction period, the initial energy input in the "hot spot" is not immediately related to the heat of decomposition of the explosive. In such cases, thermal instability is not conditioned by the heat of explosion or the mass of explosive but by other less obvious factors which apparently are related to the nature and amount of the autocatalyst

By incorporating small amounts of impurities in expls, such as LA, the thermal parameters of the Frank-Kamenetskii equation hardly change, but the induction periods notably change

The Frank-Kamenetskii equation has no explanation for the so-called *memory effect* [See Detonation (and Explosion), Heat Sensitization of Explosives and Memory Effect]

Refs: 1) W.A. Taylor & A. Weale, PrRoySoc **138A**, 92-116 (1932) (Mechanism of initiation and propagation of detonation in solid explosives) 1a) E. Burlot, CR **197**, 1223-25 (1933) & CA **28**, 2538 (1934) (Ignition of explosives in vacuo) 1b) A.F. Belyaev, DoklAkadN **18**, 267 (1938) (Origination of detonation in explosives under the action of a thermal impulse) 2) A.F. Belyaev et al, KhimReferatZh **1940**, No 10-11 & CA **37**, 1270 (1943) (Investigation of initiation of small quantities of expls by heat with an impulse lasting for 10^{-3} - 10^{-4} secs, showed that the more volatile the expl, the harder

it is to detonate. If volatility is decreased which can be done by increasing the pressure, many expls deton quite easily. For example, NCl_3 required several thousand degrees to deton it under atm pressure, but only 170° for deton under 100 atms. NG could not be detonated under atm pressure, but detonated occasionally under high pressures. Expls which are practically non-volatile, such as LA could be detond under atm pressure. The more volatile the expl, the higher was the pressure necessary to decrease the energy required for deton)

3) F.P. Bowden et al, CouncilSciIndResBull **No 167**, 44 pp (1943) & CA **41**, 3297 (1947) (Detonation of NG by impact) 3a) F.P. Bowden, Ibid, No **173**, 75 pp & CA **41**, 3297-98 (1947) (Detonation of HE's by impact) 4) B. Parlin et al, "The Theory of Explosion Initiation", OSRD Rept **2026** (1943); PBL Rept 34751 (1943) 5) E.M. Boggs et al, "Initiation Studies in Solid Explosives", OSRD Rept **5617** (1945)

6) G. Hertzberg & G.R. Walker, "Optical Investigation of Initiation and Detonation", NatlResCouncil, Canada, Project **XR-84** (Mar 1945-Aug 1946); Nature **161**, 647-48 (1948) 7) G. Gamow, PhysRev **72**, 170 (1947) (The problem of explosive initiation)

8) G.B. Kistiakowsky, "Initiation of Detonation of Explosives", GibbsChemLabRept **No 1**, Harvard Univ, Cambridge, Mass (Dec 1948) (ONR Contract No 5 ori 76, TO XIX, NR-053-094) 8a) A.R. Ubbelohde, TrRoySoc **241A**, 280-86 (1948); Research (London) **3**, 207-12 (1950) (The sensitiveness to initiation by mechanical action has been examined in relation to heat for LA, MF and, in some cases, for LSt, in order to see how far mechanical action could be equated with local heating. For primary expls, the process which "triggers" energy release may involve thermal or tribochemical activation of the molecules)

9) A.J.B. Robertson, "The Thermal Initiation of Explosion in Liquid Explosives", 3rdSympCombstn (1949), p 545-51 9a) G.B. Kistiakowsky, "Initiation of Detonation of Explosives", Ibid, pp 560-65 (31 refs) 9b) E.H. Eyster et al, "The Sensi-

tivity of Big Explosives to Pure Shocks", NCLM **10336**(1949) 10) E. Burlot, MAF **23**, 185-93(1949) & CA **44**, 8567(1950) (Investigation of conditions under which solid expls would detonate when hit by solid metallic or non-metallic missiles moving with various high velocities) 11) P. Gray & A.D. Yoffe, Research (London) **2**, 339-40 (1949) & CA **43**, 8139(1949) (A theory is proposed that initiation in liquid expls by light impact is due to the adiabatic heating developing into ignition during sudden compression of small trapped gas bubbles. Some lab tests confirmed the idea of vapor-phase flammation prior to the decompn of the liquid) 11a) A.R. Ubbelohde, Research (London) **3**, 207-12(1950) (Activation processes in expls) 12) G.B. Kistiakowsky, "Initiation and Mechanism of Detonation", pp 959-60 in Kirk & Othmer **5**, (1950) (Not found in later edition) 13) F.B. Bowden, PrRoySoc **204A**, 20-5 (1950) & CA **45**, 10588(1951) (Initiation of an expln and its growth to deton) 13a) A.J. Mooradian & W.E. Gordon, JChemPhys **19**, 1166-72 (1951) & CA **46**, 1257(1952) [The development of deton from a shock wave (produced by a detonating mixt such as $2H_2 + O_2$, contained behind a Cellophane diaphragm) propagated into expl mixt of gases was detd by means of piezoelectric gages. The strength of the initiating shock wave could be increased by making the $H_2 + O_2$ mixts richer in H_2 . With a sufficiently strong shock wave, the detonation above the stable velocity was immediately established and it decayed smoothly to the steady state. When the shock wave was weaker than required for deton, the phenomena which ensued depended upon the strength of the shock wave and the nature of the medium. A zone of combustion, accompanied by a build-up of the pressure, developed in the wake of the shock front. This led sometimes to: a) smooth acceleration of the latter until detonation was established b) formation of shock waves which overtook the front and caused deton or c) decay of the initial shock without deton. Compn and pressure limits were observed beyond which

deton could not be initiated in any case. Near these limits there was always a "spin" in the deton, which appeared on the pressure record as a periodic oscillation of the pressure for some distance behind the wave front] 14) G.B. Kistiakowsky, IEC **43**, 2794-97(1951) & CA **46**, 2266(1952) (Initiation of deton in gases. Published theories of deton are reviewed, and some new thoughts on the structure of deton waves and the mechanism of initiation of deton by flames are presented) 14a) F.R. Bowden & A.D. Yoffe, "Initiation and Growth of Explosion in Liquids and Solids", Cambridge-UnivPress, England (1952) 14b) J.A. Fay "Initiation of Detonation in $2H_2 + O_2$ Mixtures by Uniform Shock Waves", pp 501-07 in 4thSympCombstn (1952) 14c) L. Médard, MP **34**, 101(1952) (Aptitude à la détonation) 14d) Taylor (1952) (Sensitiveness of expls) 15) L. Deffet & M. de Coster, Explosifs (Belgium) **5**, 106-13(1952); Chim & Ind (Paris) **69**, 490(1953) & CA **49**, 6605-07 (1955) (Initiation to deton of solid expls by X-ray flashes. The method consisted of producing a flux of X-rays of an extremely short period, such as less than 1 microsecond, using detonators contg 0.45 g MF & 0.75 g TNT. Radiographs taken at various times after beginning of deton, such as 7 to 24 microsecs, showed that expansion of deton gas occurs laterally and that the forward part of the detonator hardly moved. The deton of MF was slowed down by that of TNT. It has been shown that the form of deton wave can be detd by this method) 16) E. Graf & J.W. Frost, "A Photographic Study of the Initiation of Detonation Waves by Deflagration", USAF Inst of Tech, Wright-Patterson AFB, (Feb, 1954) 16a) B.L. Hicks, JChemPhys **22**, 414(1954) (Thermal initiation of explosives) 16b) L. Deffer, Explosifs (Liège) **7**, 27-32(1954) (Theoretical discussion on sensitiveness to initiation) 16c) W.E. Garner, "Chemistry of the Solid State", Academic Press, NY (1955), Chap 11, paper by H.R. Ubbelohde, entitled "Explosion and Detonation in Solids" 17) J.A. Poirier, "Apparent Point of Initiation", SRI (Stanford Research

- Institute), Poulter Laboratories, Interim Report **021-55**(1955) 17a) H.L. Selberg, Applied Sci Res A **5**, 450-52(1955) (Initiation of NG by shock waves) 17b) M. Zippermayr, Explosivst **3**, 25-40(1955) (Investigation of initiation of liquid explosives) 18) J.M. Dewey, "Initiation of Military Explosives by Impact", 2ndONR-SympDeton (1955), p 484 (Investigation of initiation of bare Tetryl pellets by projectile impact showed that the smallest US standard round producing high-order deton was the caliber .60. A cal .30 carbine ball only occasionally initiated at velocities above 1000 m/sec, while more streamlined small-arms projs merely powdered the chge at vels as high as 1500 m/sec. A flat, normally-i impacting surface of proj was much more effective, as has been previously reported by British investigators) 18a) J.M. Dewey, BRL Rept **901**(1955), Dept of the Army Project 5B03-04-002; OrdnRes & DeveltProj TB3-0112 (Conf) 18b) L. Cosner & R.W. Sewell, "Initiation of Explosives Through Metal Barriers", Paper presented at Symposium on Detonation Wave Shapings; JetPropulsionLab, Pasadena, Calif, June 5-6 (1956) 18c) F. Solymosi, MagyKemFolyoirat **7**(8), 346-52(1956) (Initiation of expln of Amm Perchlorate with Cr_2O_3 - TiO_2 catalyts) 19) P.E. Skidmore & D.E. Thompson, "Development of an Improved Method for Determining Impact Sensitivity of Liquid Explosives", ABL Rept **ABL/X-10** (1957) 19a) J.E. Sinclair, "The Effect of Explosive Mixture upon Impact Sensitivity", US Naval Postgraduate School Tech Rept **No 16**, ONR Proj Order NR-051-350(1957) 20) A.V. Grosse et al, JACS **79**, 6341-42(1957) (Initiation to deton of liquid oxygen-liquid methane solns) 21) K.E. Spells & D.W. Woodhead, Nature **179**, 251-52 (1957) (Initiation of deton by projectile impact) 22) F.P. Bowden et al, Nature **180**, 73-5 (1957) (Initiation & growth of expln in solids) 22a) T.E. Holland et al, JAppl-Phys **28**, 1217(1957) (Phenomena associated with detonation in large single crystals) 23) D.C. Slade & J. Dewey, "High Order Initiation of Two Military Explosives by Projectile Impact", BRL Rept **1021**(1957), Aberdeen PG, Md (Dept of the Army Proj 5B03-04-002; Ordn Res & Development Proj TB3-0112) (12 refs) (Projectiles of various types were fired from accuracy barrels at the flat surfaces of bare (or covered with metallic or plastic plates) discs of Tetryl and Composition B. The velocity of each round was measured and the charge photographed at impact to det the result. The angle of impact was varied by tipping the chge. The Tetryl chges were, for the most part, 1.5 inch in diam & 1 inch thick. Some 2 inch & some 0.5 inch chges were used and no effect of size was observed. The d was $1.54 \pm 0.02 \text{ g/cm}^3$. The Comp B chges were 2 inch in diam & 1 inch thick, with d 1.70. All chges were radiographed to check uniformity. The results of tests showed that the velocity of proj for 50% initiation is a function of contact area but not of mass nor of the form of the proj behind the contacting area. Firings of projs against chges covered with steel plates showed that the velocity for 50% initiation increased approx linearly with the thickness of the plate. A 1/16 inch polystyrene plate increased the 50% velocity about as much as steel of the same thickness, while an Al plate of greater thickness had little effect. The velocity for 50% initiation of Comp B was about twice that for 50% initiation of Tetryl by the same proj at the same angle of impact and with the same cover plate. At -58°C the 50% vel for Tetryl was 15% higher than at $20-30^\circ$, while that for Comp B was not significantly different. Estimates of the time and position of the initiation showed that it occurred within 5 microsecs of impact and in advance of the impacting surface. The theory that projectile impact initiates the detonation by transmitting a compression into the explosive predicts these results, but detailed interpretation requires further experimentation) 24) G.J. Horvat & E.J. Murray, "Propagation of Detonation in Long Narrow Cylinders of Explosives at Ambient Temperature and at -65°F ", PicArns SFAL-TR

2389(1957) 24a) G.P. Cachia & E.G. Whitbread, "Initiation of Explosives by Shock", Royal Society Symposium on the Initiation and Growth of Explosion in Solids, Paper No 20, May 30, 1957 [Proc Roy Soc

246A, 268-73 (1958)] 24b) C.W. Lampson & R.J. Eichelberger, "Initiation of Solid Explosives by Shock Waves and Impact", Ibid, Paper No 21 (1957) 25) Dunkle's Syllabus (1957-1958): pp 137-38 (Frank-Kamenetskii formulation); 151-62 [Session 13, entitled "Heterogeneity of the Initiation Process", includes initiation of solid expls by impact, friction, thermal effect, elastic waves by ultrasonic vibrations, electromagnetic energy and chemical influence.

Spontaneous initiation during growth of crystal in solution was noted at PicArns by Dr J.V.R. Kaufman in α -LA and by Dr G.T. Rogers in β -LA. Such a phenomenon is probably due to release of energy in small regions on release of strain by fracture along a cleavage plane (p 154); Competing theories (pp 154-57); Critical mass and energy (pp 157-59); Thermal theory of initiation presented by T.W. Stevens (pp 159-61); Thermal effects of impact (pp 161-62); 191-202 [Session 17, entitled "Mechanism of Initiation and Propagation", includes The Rayleigh-Mikhel'son transformation in detonation (pp 191-94); Shock processes and initiation (194-96); Progress of the detonation wave (196-98); Transmission of energy (198-200); Rarefaction and release waves (200-202)]; pp 291-92 (Initiation by shocks; discussion on works of Poulter, Riabinin, Mooradian & Gordon, Taylor and Oppenheim); 292 [Remark that Dr R.C. Ling obtained, during his work at PicArns, evidence that the important property of "shock pulse", (in connection with initiation by shock), is the rate of application of pressure rather than its magnitude. He has gained considerable success in correlating his data on detonation parameters with a "power factor" which represents the time rate of expenditure of energy] 26) Cook (1958), p 84 [SPHF (shock-pass-heat-filter) initiation of expls]; 172-205 (Initiation of deflagration and detonation); 216-21 (Explo-

sion of solids in high velocity impact; 313 (Propagation of detonation in air blasts); 330-34 (Initiation of detonation by underwater shocks); 352 (Initiation time lag by underwater shock) 26a) J.M. Majowicz & S.J. Jacobs, "Initiation to Detonation of High Explosives by Shocks", NAVORD Rept 5710(1958) (Conf) (Not used as a source of info) 27) F.P. Bowden, Leader, PrRoySoc 246A, 142-97 (1958) (Discussion of the Initiation and Growth of Explosions in Solids" (There were 24 papers presented by many different authors, such as listed in Refs 27a, 28, 29, 30, 31 & 32) 27a) M.A. Cook, Ibid, p 154 (1958) (Thermal initiation of explosives) 28) C.H. Johansson et al, Ibid, 160-67 (1958) (Initiation of liquid explosives by shock and the importance of liquid break-up). See also *Compte Rendu du XXXI^e Congrès International de Chimie Industrielle, Liège, Belgium, Sept 1958* 29) K.K. Andreev, PrRoySoc 246A, 257-68 (1958) (Some considerations on mechanism of initiation of detonation in explosives) 30) G.P. Cachia & E.G. Whitbread, Ibid, 268-73 (1958) (Initiation of expls by shock) 31) W. R. Marlow & I.C. Skidmore, Ibid 284-88 (1958) (Initiation of condensed expls by shock waves from metals) (Abstracted in Ref 37b, p 17d) 32) C.H. Winning, Ibid 288-97 (1958) (Underwater shock wave initiation of cast Pentolite) 32a) G.K. Adams et al, "The Explosive Initiation of a Single Crystal of Cyclotrimethylene Trinitramine (RDX)", *Compte Rendu du XXXI^e Congrès International de Chimie Industrielle, Liège, Belgium, Sept 1958* 32b) Cook (1958): pp 172-203 (Initiation of explosive, deflagration and detonation); 203-05 (Ignition time lag); 331-35 (Initiation of detonation by underwater shocks); 352 (Initiation time lag by underwater shock); 44-60 (Velocity of propagation of ideal and nonideal detonation waves); 326-27 (Propagation of pressure wave in air); 334-36 (Shock-wave propagation in solid media) 32c) R.J. Eichelberger & M. Sultanoff, "Sympathetic Detonation and Initiation by Impact", PrRoySoc 246A,

- 274-81(1958) 33) J.M. Majowicz & S.J. Jacobs, "Initiation to Detonation of High Explosives by Shocks", AmerPhysSocBull, Ser II, **3**, 293(1958) (10th Anniversary Meeting of the Division of Fluid Mechanics, Lehigh Univ, Bethlehem, Pa) 33a) L.G. Bolkhovitinov, DoklAkadN **125**(2), 322-24(1959) (A possible mechanism for the initiation of liquid expls) 33b) Ibid, **125**(3), 570-72(1959) (On the theory of the initiation of an explosion by the falling weight test) 34) H.W. Hubbard & M.H. Johnson, JApplPhys **30**, 765-69(1959) (Initiation of detonations) 34a) Baum, Stanyukovich & Shekhter (1959), pp 46-71 (Initiation of explosion by shock and friction); 72-80 (Initiation of expln by heat); 272-317 (Initiation and propagation of detonating processes) 34b) M.A. Cook et al, JApplPhys **30**, 1579-84 & 1881-92(1959) (A theory of initiation of expls) 34c) D.B. Moore & G.M. Muller, "Electrical Initiation of Insensitive Explosives", PoulterLabTechRept **016-59** (1959) 34d) P. Gray & M.J. Harper, "Thermal Explosions - Part I. Induction Periods and Temperature Changes before Spontaneous Ignition", TrFaradSoc **55**(4), 581-90(1959) 34e) G.M. Muller & D. Bernstein, "Initiation of Explosives by Internal Heating", Ibid, Rept **007-59**(1960) 34f) J. Zinn & C.L. Mader, JApplPhys **31**, 323(1960) (Thermal initiation of expls) 35) J. Wenograd, "A Photographic Study of Explosion Initiated by Impact", pp 10-23 in the 3rdONRSympDeton(1960) (Two photographic methods have been used to observe the course of explns as they occur in impact testing) 35a) W.R. Hess & R.C. Ling, "On the Memory Effect in the Thermal Initiation of Explosives", Ibid, 42-49(1960) 35b) G.M. Muller et al, "Electrical Initiation of RDX", Ibid, pp 88-111(1960) 35c) R.B. Clay, M.A. Cook et al, "Ionization in the Shock Initiation of Detonations", Ibid, pp 150-83 (16 refs) (1960) 35d) F.C. Gibson et al, "Initiation and Growth of Detonation in Liquid Explosives", Ibid, pp 436-54(1960) 35e) C.H. Winning, "Initiation Characteristics of Mildly Confined, Bubble-Free Nitroglycerin", Ibid, pp 455-68(1960) 35f) A.W. Campbell et al, "Shock Initiation of Detonation in Liquid Explosives", Ibid, pp 469-98(1960) 35g) A.W. Campbell et al, "Shock Initiation of Solid Explosives", Ibid, pp 499-519(1960) 35h) J.W. Enig, "Growth of Detonation From an Initiating Shock", Ibid, pp 534-62(1960) 35i) G.E. Seay & L.B. Seely Jr, "Initiation of a Low-Density PETN Pressing by a Plane Shock Wave", Ibid, pp 562-73(1960) 35j) E.L. Kendrew & E.G. Whitbread, "The Transition from Shock Wave to Detonation in 60/40 RDX/TNT", Ibid, pp 574-84(1960) 36) M.A. Cook et al, TrFaradSoc **56**, 1028-38(1960) Promotion of shock initiation of detonation by metallic surfaces) 36a) Andreev & Belyaev (1960), 265-68 (Starting impulse and mechanism of initiation); 268-70 (Initiation by heat); 270-73 (Initiation by flame); 273-86 (Initiation by shock or friction); 287-89 (Initiation of expln in projectiles on hitting a target) 36b) J. Favier & C. Fauquignon, MP **42**, 65-81(1960) (Initiation of expls and transmission of detonation) 37) D.B. Moore & J.C. Rice, "Detonation of Secondary Explosives by Lead Azide", SRI (Stanford Research Institute), Poulter Laboratories, Technical Report **004-60** (1960) 37a) S.J. Jacobs, AmRocketSocJ **30**, 151-58(1960) (Recent advances in condensed media detonation) 37b) Dunkle's Syllabus (1960-1961), pp 4a & 4b (Initiation of shock waves); 10a-10g (Initiation of deflgrn and deton); p 12a (Frank-Kamenetskii formulation); p 13b (Initiation by electric discharge); p 13f (Thermal Decomposition and Initiation of Explosives, as discussed by B. Reitzner); pp 17a to 17e (Mechanism of initiation and propagation of detonation in solid explosives); pp 17e & 17f [Marlow & Skidmore (Ref 31) concluded from their investigations that the problem of shock initiation is somehow related to the temperature distribution in the shock pulse and its effect on the chemical reaction rate. They used an Arrhenius type relationship for the rate increase in the frac-

- tion of the total energy per unit mass liberated by the chemical reaction]; p 18c [Burlot (Ref 1a) reported that below a certain pressure limit (>1 mm for MF and ca 0.02 mm for LA), complete decomposition of any kind could not be initiated quickly by purely thermal means, and that a combustion phase precedes the detonation of both expls. At a pressure of 0.05 mm, LA decomposes only partially, leaving agglomerates of blackened lead] 37c) J. Fauvier & C. Fauquignon, "Initiation de la Détonation par Choc dans les Explosifs Solides", Colloques Internationaux du Centre National de la Recherche Scientifiques, Les Ondes de Détonation, Gif-sur-Yvette, France, August 1961 38) A. Maček, ChemRevs **62**, 53-56(1962) (Initiation of detonation by shock) 38a) J.R. Travis, A.W. Campbell et al, "Shock Initiation of Explosives. III. Liquid Explosives", Ibid, No **109**, 45-57(1961) (Eng); also in PhysFluids **4**(4), 498-510 & 511-21 (1961); CA **65**, 3660(1966) 38b) W.H. Andersen & R.F. Chaiken, Am-RocketSocJ **31**, 1379-87(1961) (Detonability of solid composite expls) 38c) C. Fauquignon, MP, Annex **43**, No 695, 69 pp (1961) & CA **56**, 10437(1962) (Initiation of detonation of solid expls by shock) 38d) G.E. Seay & L.B. Seely, JApplPhys **32**, 1092-97(1961) (Initiation of low density compressed PETN by a plane shock wave) 38e) F.C. Gibson et al, "Studies on Deflagration to Detonation in Propellants and Explosives", USBurMinesSummary Rept **3863** (1962); ARP Order Nos 44-59 & 44-61 38f) F.C. Gibson et al, "Initiation of Detonation Resulting from Combustion Instabilities", USBurMinesInterimReport, 31 Aug, 1962 (ARPA Order No 44-62) (Conf) (Not used as a source of info) 39) EighthSympCombstn (1962). The following papers dealing with initiation were presented at the Symposium. 39a) J.F. Wehner & T.D. Phillips, "The Initiation of Detonation by the Impact of Explosively Driven Solids", pp 767-73 39b) C.H. Johansson et al, "The Initiation of Solid Explosives by Shock Waves," pp 842-47 40) F.P. Bowden & A.D. Yoffe, Endeavour **21**, 125-36(1962) & CA **58**, 1293-94(1963) (Explosions in liquids and solids) 40a) J. Zinn & R.N. Rogers, JPhysChem **66**, 2646-53(1962) & CA **58**, 3262(1963) (Thermal initiation of expls) 40b) C.L. Mader, "The Hydrodynamic Hot Spot and Shock Initiation of Homogeneous Explosives", LASL Rept **LA-2703** (1962) 40c) H.S. Leopold & D. McVaney, "The Growth of Detonation of Low Density Explosive Mixtures", NOL (NavalOrdnLab) TechRept **68-79** (1962) 40d) T. Boddington, "Shock Initiation of Explosive Single Crystal", Proc6thInternlCongrHighSpeedPhotography, Scheveningen, Netherlands **1962**, 508-13 (Pub 1963); CA **60**, 14326(1964) 40e) F.C. Gibson et al, "Initiation of Detonation by Low Amplitude Shocks", USBurMines Quarterly Rept, 1 August - 31 October 1963 (ARPA Order No 44-63) 41) L.B. Seely, "A Proposed Mechanism for Shock Initiation of Low Density Granular Explosives", Proc of 4thElectricInitiatorSymp at Franklin Inst, Phila, Pa, 1963, Paper 27 of Rept EIS-A2357 41a) C.L. Mader, PhysFluids **6**, 375-81 & CA **58**, 8844(1963) (Shock and hot spot initiation of homogeneous expls) 41b) R.A. Strehlow & H.B. Dwyer, AIAA-J **1**(3), 591-95(1963) & CA **62**, 12966(1965) (One dimensional detonation initiation) 41c) K.K. Andreev & Yu.A. Terebilina, "Teoriya Vzryvchatykh Veshchestv; Sbornik Statei" (Theory of Explosive Substances; Collective Papers), Oborongiz, Moscow (1963), pp 53-71; CA **59**, 1285(1963) (Initiation of expls by shock and a method for characterizing the sensitivity of expls to mechanical effects) 41d) A.N. Dremin et al, ZhPriklMekh i TekhnFiz **1963**, No 6, 131-34 & CA **60**, 14326(1964) (Initiation of deton in molten TNT by a shock wave). Engl translation by M.E. Backman, published as NAVWEPS **9044**, NOTS TP **4049**, China Lake, Calif (1966) 42) NinthSympCombstn (1963). The following papers dealing with initiation of expls were presented at the Symposium: 42a) E.R. Litchfield et al, "Direct Electrical Initiation of Freely Expanding Gaseous Detonation Waves", pp 282-86

- 42b) F.P. Bowden, "The Initiation and Growth of Explosion in the Condensed Phase", pp 499-516
- 42c) S.J. Jacobs et al, "The Shock-to-Detonation Transition in Solid Explosives", pp 517-29
- 42d) G.E. Seay, "Shock Initiation of Granular Explosives Pressed to Low Density", pp 530-35
- 42e) F.F. Warner, "The Initiation of Detonation in Solid Explosives", pp 536-44
- 42f) G.K. Adams, "Theory of Detonation in Solid and Liquid Explosives", *Ibid*, 545-52 (1963)
- 43) C.H. Winning, *Explosivst* **11**, 34-8 (1963) (Initiation of NG) 43a) C.H. Johansson & S. Alfredsson, *Explosivst* **12**, 200-203 (1964) (Determination of initiation power of booster chges) 43b) K. Yamamoto, *KôgyoKayakuKyôkaishi* **25**(6), 330-42 (1964) & *CA* **64**, 3273 (1966) (Sensitivity of primary explosives to mechanical action)
- 44) F.C. Gibson et al, "Fundamentals of Initiation of Detonation", *USBurMines Quarterly Reports QR Nos 1 & 2* (Feb-July, 1964) (BuWeps Order 19-64-8047-WEPS)
- 44a) J. Hershkovitz & E.W. Dalrymple, "Study of the Combustion of a Granular Explosive by Observation of Stress Waves in Surrounding Lucite", *PATR* **3185** (1964)
- 44b) Donna Price & F.J. Petrone, *JApplPhys* **35**(3), Pt 1, 710-14 (1964) (Detonation initiated by high-pressure gas loading of a solid explosive) 44c) R.I. Soloukhine, *ZhPriklMekhan i TekhnFiz* **1964**(4), 42-8 (Detonation in a gas by heat from a shock wave) 44d) C.H. Johansson, *Explosivst* **13**, 327 (1965) (Initiation properties of boosters in expls with low sensitivity) 44e) T.P. Liddiard & S.J. Jacobs, "Initiation of Reaction in Explosives by Shock", *NOLTR* **45** TenthSympCombstn (1965). The following papers dealing with initiation were presented at the Symposium:
- 45a) D.C. Pack & F.J. Warner, "Whitham's Shock-Wave Approximation Applied to the Initiation of Detonation in Solid Explosives", pp 845-53
- 45b) V.M. Boyle et al, "Pressure Measurement During Shock Initiation of Composition B", pp 855-61
- 46) FourthONRSympDeton (1965). The following papers dealing with initiation, ignition, growth of reaction, etc were presented at the Symposium:
- 46a) L. Deffet & C. Fossé, "Axial Initiation of Multicomponent Explosives Charges", pp 156-66
- 46b) J.B. Ramsay & A. Popolato, "Analysis of Shock Wave and Initiation Data for Solid Explosives", pp 233-38
- 46c) M.C. Chick, "The Effect of Interstitial Gas on the Shock Sensitivity of Low Density Explosive Compacts", pp 349-58
- 46d) M.W. Evans et al, "Shock Initiation of Low Density Pressings of Ammonium Perchlorate", pp 359-72
- 46e) E.F. Gittings, "Initiation of a Solid Explosive by a Short-Duration Shock", pp 373-80
- 46f) F. David et al, "Oblique Impact of a Layer of Explosive by a Metal Plate", pp 381-85
- 46g) J.R. Travis, "Experimental Observations of Initiation of Nitromethane by Shock Interactions at Discontinuities", pp 386-93
- 46h) C.L. Mader, "Initiation of Detonation by the Interaction of Shock with Density Discontinuity", Abstract on p 394; published in *PhysFluids* **8**, 1811-16 (1965)
- 46i) J.W. Enig & F.J. Petrone, "An Equation of State and Derived Shock Initiation Critical Conditions for Liquid Explosives", Abstract on p 395; Comments, pp 395-98. Paper published in *PhysFluids* **9**, 398 (1966)
- 46j) John Eadie, "The Effect of Wax on the Shock Sensitivity of Explosive Compacts", pp 399-403
- 46k) J. Savitt et al, "Direct Contact Detonation Sensitivity", pp 404-11
- 46l) J.E. Hay et al, "The Effect of Physical and Chemical Properties on the Sensitivity of Liquid Explosives", pp 412-25
- 46m) W.R. Marlow, "Detonation Caused by the Reflection of Divergent Waves", pp 426-31
- 46n) N. Lundborg, "Comparison Between Shooting and Barrier Tests", pp 432-34
- 46o) C.H. Johansson & T. Sjolín, "The Initiation Properties of Boosters in Explo-

- sives with Low Sensitivity", pp 435-41
- 46p) R.H.F. Stresau, "Size Factors in Detonation Transfer", pp 442-48
- 46q) R.H.F. Stresau, "Confinement Effects in Exploding Bridgewire Initiation of Detonation", pp 449-61
- 46r) R.F. Chaiken & F.J. Cheselske, "Surface Rate Processes and Sensitivity of High Explosives", Abstract on p 461. Paper published in *JChemPhys* **43**, 3228-36 (1965)
- 46s) N. Griffiths & V.C. Broom, "Low Order Reactions in Shocked Explosives", pp 462-72
- 46t) H.S. Napadensky, "Initiation of Explosives by Low Velocity Impact", pp 473-76
- 46u) L.G. Green & G.D. Dorough, "Further Studies on the Ignition of Explosives", pp 477-86
- 46v) T.P. Liddiard Jr, "The Initiation of Burning in High Explosives by Shock Waves", pp 487-95
- 46w) W. Kegler & R. Schall, "Mechanical and Detonation Properties of Rubber Bonded Sheet Explosives", pp 496-501
- 46x) G.K. Adams & M. Cowperthwaite, "Explicit Solutions for Unsteady Shock Propagation in Chemically Reacting Media", pp 502-11
- 46y) G.P. Cachia, "Summary Paper on Initiation, Ignition and Growth of Reaction", pp 512-16
- 46z) J.R. Travis, "Electrical Transducer Studies of Initiation in Liquid Explosives", pp 609-15
- 47) H. Sano, *KōgyoKayakuKyōkaishi* **26**(1), 40-6 (1965) (Japan), *CA* **64**, 3274 (1966) (Initiation of blasting caps by electric waves; review with 10 refs)
- 47a) H. Osada & N. Kakinouchi, *Ibid* **26**(4), 200-11 (1965) (Japan); *CA* **64**, 3273 (1966) (Initiation of ignition of solid composite propellants)
- 47b) D. Bernstein & R.C. Goettelman, *RevSciInstr* **37**(10), 1373-75 (1966) & *CA* **65**, 18416 (1966) (Generation of cylindrically symmetric implosions by mousetrap action: "An explosive configuration was developed for going from a single initiation point to a cylindrically symmetric, converging detonation front. This technique utilizes the mousetrap concept, but in a cylindrical geometry rather than the usual plane geometry. The mousetrap action results in the simultaneous initiation of the outer surface of an explosive cylinder 15.9 cm in diam and 5 cm long. The breakout of the detonation front was monitored as a function of axial position in a cylindrical hole 5 cm in diam. The azimuthal simultaneity was studied by monitoring the resultant collapse of a thin-walled Al tube inside the explosive cylinder. Submicrosec simultaneity was attained")
- 48) Eleventh Symp Combstn (1967). The following papers on initiation are listed in the Symposium:
- 48a) L. Zernow et al, "Application of Two-Dimensional Computations to the Study of Sub-Critical Initiation and Fadeout in Homogeneous Explosives", pp 645-56
- 48b) P.A. Urtiew & A.K. Oppenheim, "Detonative Ignition Induced by Shock Merging", pp 665-70
- 48c) Donna Price, "Contrasting Patterns in the Behavior of High Explosives", pp 693-702 (Initiation by shock is discussed on pp 697-98)
- 48d) R. S. Brokaw, "Ignition Kinetics of the Carbon Monoxide-Oxygen Reaction", pp 1063-73
- 48e) P. Gray & P.R. Lee, "Studies on Criticality: Temperature Profiles in Explosive Systems and Criteria for Criticality in Thermal Explosions", pp 1123-31
- 48f) P.G. Ashmore et al, "Experimental Investigations of Conductive and Convective Heat Transfer in Relation to Thermal Ignitions", pp 1133-40
- 49) C.G. Dunkle, private communication, January, 1968
- 50) Twelfth Symp Combstn (1968) (Pub 1969). The following papers on initiation, ignition, etc were presented at the Symposium:
- 50a) G.L. Schott, "Chain-Branching and Initiation Rates Measured by Spatially Integrated Light Emission during Reflected Shock-Wave Ignition", pp 569-78
- 50b) C. Fauquignon & R. Cheret, "Generation of Detonation in Solid Explosives",

pp 745-51

50c) L.G. Bolkhovitinov et al, "Initiation of Detonation in Low-Density Trotyl by Air Shock", pp 771-77

50d) G.G. Bach et al, "Direct Initiation of Spherical Detonations in Gaseous Explosives", pp 853-64

Addnl Refs: A) E. Jones & D. Mitchell, "Spread of Detonation in High Explosives", *Nature* **161**, 98-99 (1948) [In granular solid expls (TNT or Tetryl) as in liq & gelatinous expls, an initial unstable phase may change abruptly to a higher level deton. The length of the initial slow phase ("pre-detonation phase") decreases with increasing strength of the initiator and may decrease to zero with high density compressed cartridges. On the other hand, its duration is increased in a narrow cartridge or when a sufficiently coarse grist of expl is used, so that a uniform & stable low-velocity deton may be produced in which some of the expl remains undecompl]

B) G.M. Mason et al, "The Physics and Chemistry of the Explosives Phenomena", *USBurMinesProgressRept* Oct-Dec 1950, Contract NA-onr-29-48, Project NR-053-047 (Propagation of the deton wave thru various lengths of the non-expl substances was detd by placing a non-expl pellet of known length betw two expl pellets. If deton of one of the expl pellets caused a complete deton of the 2nd expl pellet, it was reported that the non-expl pellet is capable of propagation of the deton wave. PETN caused propagation thru up to 12 mm long Al pellets and up to 16 mm long Na chloride or graphite pellets. Tetryl caused propagation thru 16 mm NaCl pellet, but TNT caused no propagation at all)

C) W. Cybulski, *PraceGłównegoInstGórnictwa*, Ser A Komun No **167**, 32 pp (1954) & *CA* **50**, 10409 (1956) (Investigations of relation between propagation of deton of mining expls and the diameter of the cartridge)

D) *Ibid*, No **169**, 30 pp (1955) & *CA* **50**, 10410 (1956) (Investigation of propagation of detonation of mining expls by photographic method)

E) S.J. Lowell, "Propagation of Detonation in Long and Narrow Columns of Explosives," *PATR* **2138** (1955) (Conf) (Not used as a source of info)

F) I. Jaffee et al, *AmRocketSocJ* **32**, 22-5 (1962) & *CA* **56**, 11872 (1962) (Shock pressure required to initiate detonation of an acceptor in the shock sensitivity test)

G) N. Griffiths et al, "Some Aspects of Shock Initiation of Condensed Explosives", *Combustion & Flame* **7**, 347-52 (Dec 1963)

Detonation (and Explosion), Initiation & Shock Processes. Detonation Head and Detonation Edge

Different types of explosions are possible in the same explosive substance, depending on the method of initiation. Hot-wire ignition could not detonate acetylene-oxygen mixts but produced only deflagration, while sparks detonated mixts contg from 14 to 60% C_2H_2 . PETN detonators extended the range to 5.3% C_2H_2 , but in such weak mixts the wave trace was very faint and its propagation velocity low

H. Scharadin (as quoted in Ref 4, p 194) in his lecture at Stevens Institute of Technology, Hoboken, New Jersey, in 1954, reported that ethane-oxygen mixts in spherical cellophane containers 2 m in diam could be initiated with a LA chge, placed in the center of sphere, to produce a deton velocity of 2000 m/sec. Attempts to start the deton with any source of heat led only to combustion wave. Chges of LA less than a critical size had the same effect, but on increasing the chge to the critical, about a ten-fold increase in the propagation rate was obtained; further increases in detonator chge made very little change in the velocity

In some cases, simple burning or deflagration goes over to detonation, after more or less delay. As an example, may be cited MF in which detonation is preceded by a very short period of burning, which started on the surface of the grains and proceeded inward. LA, on the contrary, seemed to detonate directly and it was suggested that it is normally initiated within interior of the grains (See Note)

Experiments of Ubbelohde (as quoted in Ref 4, p 195) showed that when the air surrounding the crystals of LA was replaced by liquids of high bp, so as to change the surface tension of the medium, it was possible to initiate LA by a "burning" ("self-heating") process. The initiating impulse for this type of compd may be a rise of temperature, impact, friction, the breaking of a crystal, or even allowing the surface of crystal (such as of nitrogen iodide) to become dry. Sometimes LA detonated during process of crystallization (Ref 6, pp 13c & 17d)

Note: Mr. Dunkle remarked that it used to be thought that LA always detonates without any preliminary deflagration, but this does not seem to be true [See Note 1 under Detonation (and Explosion), Induction Period]. E. Burlot, CR **197**, 1223-25 (1933) claimed that at very low pressures such as 0.02 mm combustion precedes detonation in both LA and MF

In order to produce a detonation, it is required that the initiator be capable of generating a shock wave in the base (HE) charge. When this shock wave reaches an expl chge, it imparts the energy which usually suffices to trigger off a rearrangement of the atoms resulting in release of far more energy than was applied. The "breaking stress" is thus passed on to other molecules susceptible to such rearrangement. Behind the disturbance there is, instead of rarefaction, a strong pressure pulse due to the chemical change. Detonation gives a continuous compression as against alternate compression and rarefaction in an elastic wave

In the words of Poulter & Moore of Stanford Research Institute (quoted in Ref 4, p 197): "A normal shock pulse traveling in an inert medium is continuously doing work on the medium thru which it is traveling, and hence is continuously being attenuated and therefore decelerated. A detonation is a true shock pulse, but one in which the energy lost in attenuation is being replaced by the energy released by the chemical reaction associated with the detonation pro-

cess. The detonation velocity of an explosive is therefore the velocity of a plane shock in the explosive thru which it is traveling and in which the attenuation is just compensated for by the energy received from the chemical reaction. Consequently, anything which tends to increase the attenuation will tend to decrease the detonation rate, and anything which tends to increase the energy received will increase the detonation rate"

A spherically expanding deton wave, initiated on the axis of a cylindrical charge, decreases in curvature until the front reaches the cylindrical surface. The curvature then, instead of decreasing indefinitely, soon reaches a constant value in a steady-state wave form which thereafter propagates unchanged along the remainder of column. Behind the front, axial expansion produces *rarefaction* or *release* waves which cut into the products from the charge boundary and finally converge at the axis. By the time the front has moved about 3 charge diameters, the region of hot compressed gases has assumed the form of a cone. This is called **detonation head** by C.O. Davis, M.A. Cook & others. In a 2-in diam unconfined charge the detonation head resembles a cone of altitude 1.6 in and base slightly less than 1.75 in. The outside layer of the explosive slightly greater than 1/8-in in thickness appears ineffective in unconfined charges, possible because of the failure of the expl to detonate in this outer belt in time to contribute to the effect, at the low pressures in the outer edge of the reaction zone (**edge effect**)

In Fig 5.1 of Cook (Ref 5, p 92) is shown development of detonation head in steady-state detonation for cylindrical unconfined and confined charges, taking into consideration the spherical shape of the wave front. The *lateral rarefaction wave* of H. Langweiler model, shown in Fig, is called (accdg to Cook, p 91) the *release wave* by E.M. Pugh et al. In confined charges, the steady-state detonation head, should, in this model, be somewhat larger because confinement would lower at least the initial velocity of

the release waves from the side. For more detailed description of *detonation head*, see Refs 1, 2, 3, 4, 5 & 7. See also under the following subjects:

"Detonation (and Explosion), Development (Transition) from Burning (Combustion) or Deflagration";

"Detonation (and Explosion), Induction Period in Initiation of Explosives and Propellants";

"Detonation (and Explosion), Initiation (Birth) and Propagation (Growth or Spread) in Explosive Substances"

Refs: 1) H. Langweiler, ZTechPhysik **19**, 271 (1938) (Langweiler model of detonation head. Its Engl description is given by Cook, p 91) 2) G.B. Kistiakowsky & P.H. Kydd, 2ndONRSympDeton (1955) & JChemPhys **25**, 824 (1956) (The Langweiler model has been attacked on the basis that the rarefaction wave cannot remain abrupt but must spread out in time) 3) A.S. Filler, "Application of the Detonation Head Model to the Mass Loading of Explosives", UnivUtahTechRept **XLVI** (1955); Contract N7-onr-45107 4) Dunkle's Syllabus (1957-1958), 194-96 (Shock processes and initiation); 196-98 (Progress of the detonation wave); 285-91 (The detonation head model) 5) Cook (1958), 91-3 (Steady-state detonation head for solid unconfined and confined charges); 93-7 (Experimental detonation head in gases); 97-9 (Experimental detonation head in condensed explosives); 120-22 (Detonation head model proposed in 1943); and 128 (Detonation head in "ideal" detonation with maximum velocity transient) 6) Dunkle's Syllabus (1960-1961), pp 13c & 17d (Spontaneous detonation of LA and other primary expls during crystal growth) 7) G. Yoshikawa, "The Characteristic Growth of the Detonation Head in Dynamite", 8thSympCombstn (1962), pp 854-63 [See also Refs and Addnl Refs under Detonation (and Explosion), Initiation (Birth), and Propagation (Growth or Spread) in Explosive Substances]

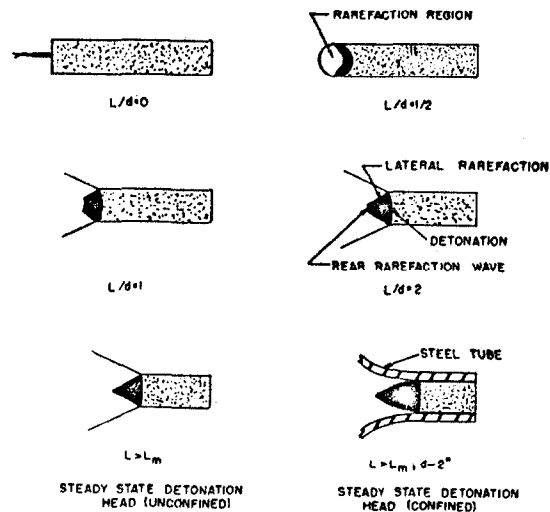

Figure 5.1. Development of detonation head

Detonation; Instability of, Unidimensional.

This subject was discussed by K.I. Shchelkin, DoklAkadN **160**(5), 1144/46 (1965) & CA **62**, 12965 (1965). Following is its abstract: A criterion for unidimensional instability of detonation of gases is derived, taking into account the thermal effects of the reaction. Instability occurs when $[(\gamma-1)/\gamma](E/RT)[1/(1+c_g/c)]qM > 1$, where γ is the heat capacity ratio, E is the energy of activation, c_g and c are the velocities of sound in the burned and unburned gases, resp, q is the ratio of thermal effect of combustion to the internal energy of the unburned gas, and M is the ratio of the burning rate to the velocity of sound in the unburned gas

Detonation, Intermediate Order Velocities of. See under Detonation, High-, Low-, and Intermediate Order Velocities of

Detonation, Intermolecular Force-Constants of Gases. Taylor (1952), pp 37 & 38, gives intermolecular force-constants and some other properties of non-polar gases: N_2 , CO , H_2 , O_2 , CO_2 & CH_4 and of polar gases H_2O & NH_3

Detonation (and Explosion), Ionization, Electrical, Magnetic, and Electromagnetic Phenomena Accompanying It. See under Detonation (and Explosion), Electrical, Electromagnetic, and Magnetic Phenomena Accompanying It

Detonation (and Explosion), Jet-Expanding Theory of. See Detonation (and Explosion), Nozzle Theory of Jones

Detonation (and Explosion), Jet-Piercing Theory of. See Detonation (and Explosion), Penetrating or Jet-Piercing Theory of Apin

Detonation, Jetting in. Briefly defined, it is the propagation of plasma from the end of a cylindrical charge when the detonation wave emerges into the air

In Session 24 of Dunkle's Syllabus (Ref 1), entitled "The Detonation Head Model", it is stated on pp 286-87: It should be noted that if a horizontal cylindrical charge is initiated at its center, the vertical plane normal at this point to the charge axis is the equivalent of a rigid wall. In a charge under perfect confinement, which is considered to be approached for a narrow column along the axis of the charge, pressures would be held at a constant value lower than (P_{CJ}) (Chapman-Jouguet pressure) until the detonation front reaches the end of the charge. *Jetting* then follows. The material in the reaction zone at that time would be projected forward at its particle velocity (U_{CJ}), plus the root mean square velocity of thermal agitation. This would then send a rarefaction backward into the products heretofore held at constant pressure, and they would again acquire positive velocities forward. The inertia of their forward movement would then lead to low pressures behind, a rarefaction would start forward, and the sequence of events following emergence of shock and rarefaction waves from either end of the charge is shown in Fig 37, p 98 of Ref 1

The Fig shows the detonation wave passing thru the HE. It emerges from the charge at point 1, and the "first shock",

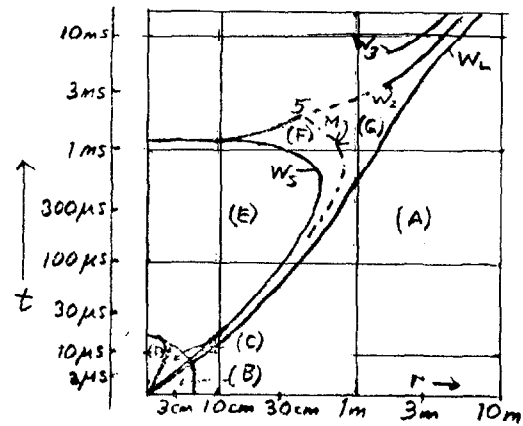

Radius-time diagram of the formation of shock waves by the detonation of a spherical charge, $\log (1/x)$ scale
Fig 37

W_L , is seen going out into the air (from both ends of the charge. The left side of the plot represents the center of a symmetrical spherical charge). The first shock is then succeeded by "a rarefaction shooting forward", and then by other shocks and rarefactions, exactly the same as in the case of jetting

From electrical conduction measurements close to detonating HE's, Udy & Cook (Ref 2) detected the production of a highly ionized plasma region. It was found to originate more directly from the explosive than from thermal ionization associated with the accompanying shock wave, and to be of the same nature as current flow in a metal

By means of microsecond framing camera photography techniques, a very highly luminous region was observed to propagate from the ends of charges when the detonation wave emerged in the air. The highly luminous region separated from the detonation products and in many instances propagated for distances of over 50 cm at high velocities. In explosions of a liquid expl within a glass beaker, the latter did not expand nor break until arrival of the detonation products after passage of the plasma, thus indicating that external pressures exerted by it were small. The plasma did

not expand significantly when it left the top of the beaker but showed remarkable tendency to hold together. The resulting plasma is classed as a "dilute plasma" (one or less free electron per atom or molecule) in contrast to completely ionized gas (Ref 3)

Refs: 1) Dunkle's Syllabus (1957-1958), pp 98, 286-87 & 343-44 2) L.I. Udy & M.A. Cook, "Propagation Characteristics of Detonation Generated Plasmas", AFOSR-TN-58-754; AD 201613 (1958) 3) Dunkle's Syllabus (1960-1961), p 24.b

Detonation, Jouguet Theory of. See Detonation, Chapman-Jouguet Theory of

Detonation, Jumping. A type of transient detonation phenomenon described by Cook (Ref 1). Several examples are given in which a combustion wave propagates at a low velocity, sometimes lower than sonic velocity in the charge, and a high-order detonation suddenly is initiated some distance ahead. This then propagates both forward and backward, but in one case dropped to a somewhat lower steady value. The "jumping" detonation appears under conditions in which the shock wave first outruns the reaction and is then suddenly overtaken after the chemical reaction has developed to a critical stage in which a *heat pulse* is able to propagate. Its definition is also given in Ref 2

Dunkle (Ref 3) made the following remark: "I hate to disagree with Cook, but I would call a 'detonation' propagating at less than sonic velocity a 'deflagration'. Evidently the wave sets up sound waves ahead which go at successively faster rates, thus 'telescoping' into a shock wave which initiates detonation some distance ahead of the low-velocity wave"

Refs: 1) Cook (1958), 57-9 & 318 2) Dunkle's Syllabus (1960-1961), p 23e 3) Dunkle, private communication, January, 1968

Detonation, Kirkwood Theory of. See Detonation, Wood-Kirkwood Theory of

Detonation, Kistiakowsky et al Equations of State. See under Detonation (and Explosion), Equations of State

Detonation (and Explosion), Langweiler Model or Langweiler Wave See under DETONATION (AND EXPLOSION) WAVES

Detonation of Large Amounts of Explosives. H. Sudo, *KogyoKayakuKyôkaishi* **23**(2), 161-64 (1962) & *CA* **60**, 11838 (1964). Data and discussion of expts with 750, 1500 and 3000 kg of various industrial explosives in an open field are given. The expansion velocity of flame, the forces of blast caused by explosion, the effects of barricade heights against the blast force, and the damage done to the magazines built of brick or reinforced concrete were examined. The relation obtained for blast force P (kg/sq cm) vs distance from the explosive to a target D (m) was $P = aD^{-n}$. Values of consts a and n are 1.01×10^3 and 1.74 for 750 kg, 1.93×10^3 and 1.78 for 1500 kg, and 3.69×10^3 and 1.81 for 3000 kg of ammonia gelatin dynamite. The higher the barricade, the better it inhibits the blast force and flying fragments. The fragments of brick magazine were finer (the radius of the blast was shorter) than those of the concrete magazine

Detonation, Large-Scale Gap Test. See Ref 42 under Detonation (and Explosion), Experimental Procedures

Detonation, Lasers in. See Detonation, Masers and Lasers in

Detonation (and Explosion), Lateral Dispersion in. See "Detonation (and Explosion), Lateral Expansion (Dispersion), etc

Detonation (and Explosion), Lateral Expansion (Dispersion) and Lateral Loss in.

When a cylindrical charge of an explosive is detonated, its expansion proceeds not only forward and backward along the cylinder axis, but also laterally along the radius. The greater the diameter of cylinder,

the lesser is the role played by lateral expansion. If the diam of charge is below a certain size (characteristic for each expl), the deton dies out, because the resistance to lateral expansion becomes too great due to lack of space. The diam at which deton dies out is known as the *critical charge diameter*, d_{cr} . This diameter, for example, for NG in a glass tube is equal to ca 2 mm (Ref 6, p 213)

Expansion of the expln products in the forward direction in a cylinder is accompanied by compression of new layers previously undisturbed in the explosion and this causes some loss of energy, which is considered, however, not as a loss, but as a normal part of the detonation process. Expansion of the expln products in the rearward direction proceeds more slowly as the path traversed by the wave in the explosive becomes greater, i.e., the thicker the layer of compressed expln products behind the wave becomes, the more slowly the expansion proceeds. Thus for a large chge diam, the more powerful is the initiator causing the initial wave, the smaller are the losses at the origin of propagation of detonation. As the wave evolves from that point, the losses connected with rearward expansion decrease. If a charge of a small diam is considered, then lateral expansion depends on the path over which the wave has traveled. The increase in cross section of a cylinder, i.e., expansion in the lateral direction, leads to a reduction in pressure and to a decrease in the deton velocity in comparison with detonation propagating in a constant cross-section cylinder. The decrease in deton vel causes, in turn, the diminution of shock amplitude wave and impairs the conditions under which the reaction can proceed. The loss caused by lateral expansion is known as *lateral loss*. Propagation of detonation is possible only if this loss is not smaller than a certain limit, which is characteristic for each expl

In the case of a condensed HE, the lateral expansion proceeds with a velocity of the same order as the velocity in forward direction (Ref 6, p 215-16)

Accdg to experiments conducted in Russia by Yu.B. Khariton and others, the lateral expansion is the main cause of detonation dying out (Quoted from Ref 6, p 216)

Eyring (Ref 1, p 21, as quoted in Ref 4, p 205) noted that lateral expansion of the deton products is important because of the strong influence of the shape of the deton front on the condition at the Chapman-Jouguet surface. It also may lead to stabilization of a sub-ideal C-J state. Among the factors exerting strong influence on deton vel, the lateral expansion is also of importance. This expansion, if at all appreciable during time, t , where reaction zone thickness is $a = Dt$, will modify the deton process because: a) part of the energy released is used in the expansion and hence does not contribute to propagation of the wave front and b) peak temperature and pressure are lower than when lateral expansion can be neglected

Eyring also stated (Ref 3, p 98, as quoted in Ref 4, p 201) that release of energy by lateral expansion of the products permits stabilization of one of the sub-ideal states in the shock front. Of the hydrodynamic equations only that of continuity, expressing the constancy of mass velocity, is perturbed by the expansion

Cook (Ref 5, p 123) discussed "lateral loss" in conjunction with non-ideal detonation and he also stated that H. Jones (who developed the Nozzle Theory) considered that, to a good approximation, the hydrodynamic equations expressing conservation of momentum and energy thru the detonation wave are unchanged by the effect of "lateral expansion"

Dunkle (Ref 10) stated: "As noted on Cook's page 123, there is an important relationship between lateral expansion and the departure of a detonation from the 'ideal', but we could not find this info on p 123 of Ref 3" (See also Refs 2, 7, 8 & 9)

Refs: 1) H. Eyring et al, "The Chemical Reaction in a Detonation Wave", OSRD Rept **3796** (1944), p 21 2) R.H. Hill &

D.C. Pack, *PrRoySoc* **191**, 524-41 (1947) (Lateral expansion of gases behind a detonating slab of explosive) 3) H. Eyring et al, *ChemRev* **45**, 98 (1949) 3a) H. Jones, *PrRoySoc* **204A**, 10-11 (1950) (Effect of lateral expansion on detonation velocity) 4) Dunkle's Syllabus (1957-1958), 201 & 205 5) Cook (1958), p 123 6) Zel'dovich & Kompaneets (1960), 213-16 7) L.D. Sadwin & N.M. Junk, "Measurement of Lateral Pressure Generated from Cylindrical Explosive Charges", *USBurMines-Report of Investigation RI 6701* (1965) 8) L.D. Sadwin & N.M. Junk, "Lateral Shock Pressure Measurements at an Explosive Column", *4thONRSympDeton* (1965), p 92-5 9) F. Wecken, "Non-Ideal Detonation with Constant Lateral Expansion", *Ibid*, pp 107-16 10) C.G. Dunkle, private communication, Jan, 1968 11) *12thSymp-Combstn* (1968) (Pub 1969). Nothing on lateral expansion

Detonation, Lateral Loss. See above item

Detonation, Lateral Rarefaction Wave. See under Detonation (and Explosion), Geometrical Model Theory of Cook

Detonation, Lateral Shock Pressure Measurements at an Explosive Column. A high speed streak camera technique used for these measurements is described by L.D. Sadwin & N.M. Junk in *4thONRSympDeton* (1965), pp 92-101. Observations made in a water medium show that for several expls at various diams, the lateral pressure is 38 to 73% of the shock pressure generated at the terminal end of the explosive column

Detonation, Lennard-Jones-Devonshire Theory. See Detonation, Free Volume Theory of LJD (Lennard-Jones-Devonshire)

Detonation, LH Theory. See Detonation, Longuet-Higgins Theory

Detonation (and Explosion), Light (Flame) Accompanying It. See "Detonation (and Explosion), Luminosity (Luminescence) Produced on"

Detonation Limit. According to Gordon (Ref, p 180), "a detonation limit may be defined as a point at which the wave just fails to propagate at a steady rate, even when overdriven initially"

Ref: W.E. Gordon, "Detonation Limits in Condensed Explosives", *4thONRSympDeton* (1965), p 180

Detonation Limits in Composite Explosives.

This subject was discussed in detail by Gordon (Ref 3) and to a lesser degree by Jost (Ref 1) and Cook (Ref 2)

Following is the resumé of Gordon's paper:

The ideal theory of detonation provides no basis for locating detonation limits. These are bound on regions of stable detonation in ranges of such variables as charge diameter, chemical composition, and density. Detonation limits result from the interacting effects of energy losses, reaction rates, and initiation processes, none of which is given more than formal recognition in the theories of Chapman-Jouguet and Zel'dovich-vonNeumann-Döring. Although the general explanation of why limits exist is known, more and better data are required to locate them numerically. The purpose of Gordon's paper is to supply the theoretical framework for the interpretation of limit phenomena in composite explosives

The composite explosives are usually those consisting of powdered mixtures of an oxidizer and an organic fuel. Dynamites are composite expls contg some NG. The composite expls examined by Gordon consisted of AN-fuel or Ammonium Perchlorate-fuel and their properties were compared with those of TNT, RRX and pure Amm Perchlorate

Most striking feature is the difference in behavior toward a change in the initial density ρ_0 . Increase in density of TNT, RDX or Amm Perchlorate causes continuous increase in detonation velocity D, while for composite expls increase of D follows increase in density only to some limiting value and then D sharply decreases. This unusual behavior of composite expls is caused, accdg to Cook (Ref 2, pp 140-41), by slowing down of the diffusion reaction between fuel and oxidizer with increase in density

The paper of Gordon describes a model for diffusion-controlled reaction based on the "hole" concept in liquids of Jost (Ref 1, p 459), in which the activation energy for diffusion is equated simply to pV . The marked effect of density, therefore, results from the strong dependence of pressure on density (p varying about as the density cubed) and the appearance of this factor in an exponential term. On this basis, Gordon derived an approximate expression for dependence of detonation velocity D on explosive density ρ_0 . This equation is given on pp 833 and 836 of Gordon's paper. From this expression the critical diameter d_c for composite explosives is related to an exponential function of density by:

$$\log_e (d_c/l) = b(\rho_0/\rho_0^*)^{2m+1}$$

where l & b are constants related to various explosive parameters, m is the exponent of order unity in the expression of ideal velocity D_∞ as a function of density ρ_0 , and the asterisk designates a reference state, say that with $\rho_0 = 1.0 \text{ g/cc}$

Experimental evidence to support this behavior is given and the implications of these results for the problem of determining critical diameter in composite solid propellants are discussed in the paper of Gordon *Refs:* 1) W. Jost, "Diffusion", Academic Press, NY (1952), p 459 2) Cook (1958), 140-41 3) W.E. Gordon, 10thSympCombstn (1965), pp 833-38

Detonation Limits in Condensed Explosives.

This subject was discussed recently by W.E. Gordon in the 4thONRSympDeton (1965), pp 179-97 (23 refs)

The paper surveys published work on detonation limits, correlates the data with other props, reviews theories on the subject, and seeks a coherent overall view. It is assumed that at the limit the deton shock strength becomes critical for initiation of reaction. The critical shock pressure is therefore a significant quantity to examine. Data obtd for ten expls (TNT, AP, EDNA, DNT, AN, Ammon Dynamite, AN/Oil, AN/

HMTeA, AN/TNT & AN/Comp B) show that chge density, *per se*, has the strongest influence on critical pressure. Another important factor is reaction zone length. Chem differences betwn expls have a minor effect; dynamites contg NG are a notable exception

The problem of sensitivity testing is also examined because deton limit data show that the critical shock pressure decreases with increasing particle size. This seems to run counter to the results of minimum booster-type sensitivity tests. The discrepancy is resolved when shock wave initiation is viewed as a combination effect of both pressure & duration

Deton limits in truly homogeneous expls require special treatment, because here the induction period for initiation of reaction is virtually equal to the reaction time. An unusual "critical density" phenomenon is encountered with AN/fuel expls. This has been attributed by Gordon to diffusion-limited reaction. This case is reviewed, and the implications concerning the question of detonability in solid composite propnlts are examined

Detonation Limits in High Explosives. This subject is discussed by Donna Price in the 11thSympCombstn (1967), pp 693-702 under the title "Contrasting Patterns in the Behavior of High Explosives". A resumé of her paper is given in Section 1 of this Vol under above title. (Compare with "Detonation Limits in Composite Explosives" and "Detonation Limits in Condensed Explosives")

Detonation Limits of Solid Explosives. See Detonation Limits of Composite Explosives and under Detonation Limits of Condensed Explosives

Detonation, Lined Cavity Effect. See under DETONATION, MUNROE-NEUMANN EFFECT

Detonation (and Explosion) of Liquid Explosives.

See Vol 3, pp C495-R to C496-R under "Condensed Explosives" and in this Vol under Detonation (and Explosion) of Condensed Explosives

Detonation, Low-Order of. See under Detonation, High-, Low-, and Intermediate-Order

Detonation (and Explosion), Luminosity (Luminescence) Produced on. (*Light (or Flame) Accompanying Detonation*). It is common knowledge that detonations (and explosions) are accompanied by light, the intensity of which is related to the temperature of detonation. This luminous phenomenon can be studied by means of High-Speed Camera Photography, such as described in Vol 2 of this Encycl under CAMERAS, HIGH-SPEED, PHOTOGRAPHIC, pp C13 to C19. For such study, the expl charge (usually cylindrical) is mounted with its axis parallel to, and in line with, the slit of the camera. A photo obtd in this way from the deton wave of a granular expl consists of a sharp bright line followed by luminous effects which are usually less intense. This is clearly shown in Plate I given in Ref 5 and reproduced here

In this case it is assumed that the leading edge of the photographic trace represents the progress of deton front along the cartridge (Ref 5, p 30)

When a cartridge of expl is fired, a shock wave develops at the sides and is communicated to the surrounding medium. The exptl studies of Muraour (Ref 3) have shown that the light from deton of condensed expls is mainly emitted by the surrounding gas atmosphere raised to a high temp by rapid compression. This temp is highest with gases of high density and low specific heat. The light can be practically eliminated when a non-porous expl is detonated in a condensed medium such as water. Dunkle (Ref 21) pointed out that luminosity of solid explosives is minimized if the charge is surrounded by a gas, such as propane

If an expl contains occluded gas, such as in case of granular expls, the light is

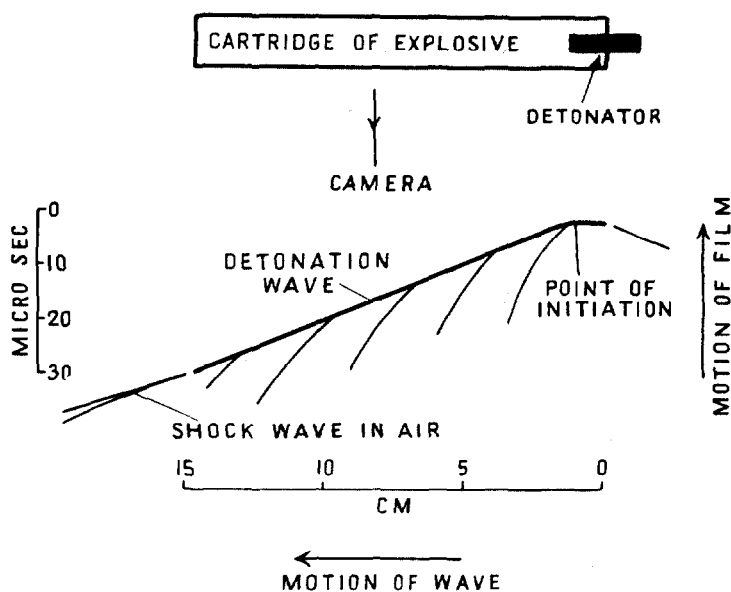
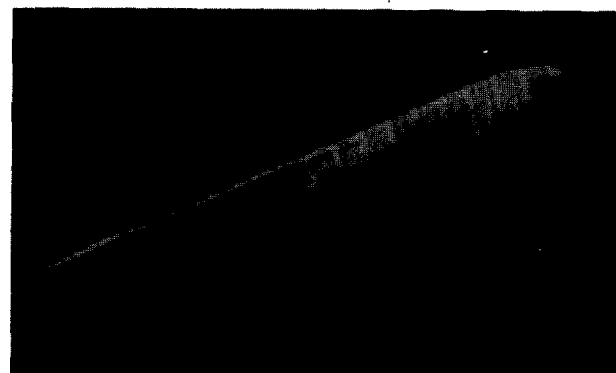

PLATE I. Typical high-speed camera photograph. The detonation velocity is 4,850 m./sec. The diagram shows the arrangement of the explosive and camera and the method of interpretation

emitted even on firing under water. It is assumed that the principal part of the light arising from granular expls is derived from the compression of air-pockets and not from the reaction itself (Ref 5, pp 31 & 155). More info on luminosity of granular expls is given in Ref 5, pp 173-74

When an "unconfined" expl is fired while suspended freely in air the shock wave which develops in the air surrounding the cartridge will attenuate rapidly as it spreads laterally, and its front will maintain the same velocity as the deton wave, provided that the wave itself is steady. The front of the shock

wave usually coincides with the deton front, but it may lie ahead of it. However, there is no doubt that the shock wave exists and that it provides much of the light photographed (Ref 5, p 31)*

If the confining material is a solid or liquid, it is quite possible for the shock wave set up in the environment to travel faster than the deton wave. As the shock waves in condensed surroundings are not luminous, they do not obscure the deton traces. An exception to this occurs when shock waves are more intense than the deton waves developed in normal expls, as for example when confining envelope consists of a friable transparent material like glass. Here the shock wave may exceed 5300 m/sec, and immediate fracture of the glass may occur ahead of the deton wave; the internal reflections from the cracks then seriously interfere with the photographic record of the deton wave (Ref 7, p 31)

The luminous zone in deton appears to have a small finite thickness. This was given by Mitchell & Paterson (Ref 1) as being less than 0.24 cm for NG, with duration of deton flame of less than 0.3 microseconds. Herzberg & Walker (Ref 2) have measured the duration of actinic radiation by high-speed camera methods and from these calculated that the luminous zones in the deton of HE's were from 0.03 to 0.09 cm thick (Ref 5, pp 154-55)

An extensive investigation of luminous radiation emitted during detonation was conducted during 1948-1953 at the USBurMines, Pittsburgh, Pa. Numerous progress reports were issued but no final report was pre-

pared. A brief description of this important work, listed here as Refs 4 & 6, is given below:

Luminous radiation emitted by an expl charge during its period of detonation* was determined by means of apparatus described in Ref 4, ProgRepts, July-Sept 1948 and Jan-March 1949. The luminous radiation passed thru a narrow slit aperture near the test charge so that only a short section of the exploding chge was observed and thus a high degree of time resolution for the traveling deton zone was attained. The radiation passing thru the aperture was incident upon a set of four multiplier phototubes located behind bullet-proof glass windows in the bomb-proof wall. The schematic arrangement of the slit system is shown in Fig 1, p D427

Radiation intensities for different regions of the visible spectrum were obt'd by placing narrow-band optical filters with transmission bands of different wavelengths directly in front of the sensitive surfaces of the phototubes. Each of the phototubes was connected thru a vacuum-tube amplifier to the vertical plates of a cathode-ray tube so that luminosity-time records at four different wavelengths of radiation could be obt'd on the driven sweep of the four-channel oscilloscope. These four luminosity-time curves for the detonating expl chge were photographed on a single frame of 35 mm film with a miniature camera and f:2.0 lens. A photograph of the four-channel oscilloscope and a typical record of the luminosity-time curves for a detonating expl charge is shown in Fig 2, Ref 5, ProgRepts, July-Sept 1948 and Jan-March 1949. It is not reproduced here. The interval markers appearing on the time base sweep were 10 microseconds apart

* Accdg to Dunkle (Ref 21), "There is not necessarily any relationship between the detonation velocity and the velocity of the shock wave in the surrounding medium normal to the shock front. It is when the shock velocity in the confining medium exceeds the detonation velocity that the shock front in said medium "runs ahead" of the detonation front

* Dunkle (Ref 21) cautions in connection with "emitted during the period of detonation", that the time of highest luminosity is not necessarily the time when the major part of the detonation reaction takes place

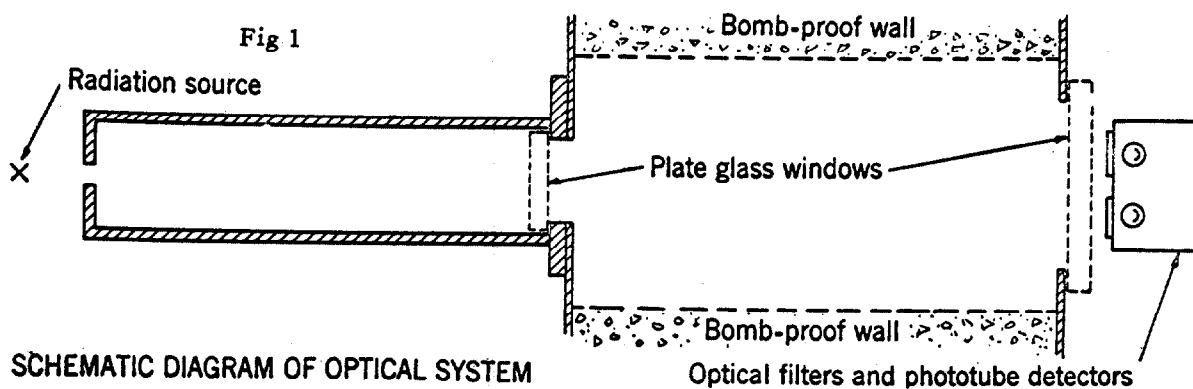

The luminosity data obtd at BurMines for various expls were used for evaluation of their temperature of detonation as described under Detonation (and Explosion), Temperature of (listed in Refs 4 & 6)

For detn of luminosity curves for PETN, the charges were in the form of sub-sieve particle diam powder contd in thin transparent plastic tubes 20 cm long and 1.90 cm in diam. The chges were prepd with an electrical circuit thru the powder near the detonator end to provide a trigger signal to the oscilloscope before the deton wave passed the section of the expl adjacent to the radiation slit aperture. The chges were suspended with the trigger wire at least 5 cm above this section of the expl; the axis of the chge was at a distance of 10 cm from the radiation aperture. Radiation apertures of various widths were used in the measurements; the slit widths were generally less than 1 cm in the plane perpendicular to the axis of the chge with an equivalent theoretical time resolution of approx one microsecond

Luminosity curves for PETN of loading d 1.60 detonated in vacuum are represented here. The left curve was photographed, using optical filters, with transmission maxima at $\lambda=6870\text{\AA}$, while for the right one λ was 4510\AA . In this type of curve, the intensities of the peaks with maximum deflection during the deton interval were used for the evaluation of temperature of detonation



Similar tests were conducted for Tetryl of loading d 1.60 and for TNT of d 1.55. Their luminosity curves for deton in air at atm pressure are given below. The left curves were taken using optical filters with transmission maxima at $\lambda=6870\text{\AA}$, while the right ones used $\lambda=4510\text{\AA}$ (Ref 5, Progr- Rept, Apr-June 1949)



In ProgrRept July-Sept 1949 are given photographs of luminosity curves for deton of PETN of loading d 1.40 in air as recorded on a sweep trace of 10 & 20 microsec duration

In ProgrRept Apr-June 1950 is given the following table of relative luminosity of "detonation peak" for three expls in pellet form:

Table I

| Expl | Pellet d | Relative Luminosity |
|--------|----------|---------------------|
| PETN | 1.64 | 1.0 |
| PETN | 1.15 | 1.0 |
| Tetryl | 1.64 | 0.30 |
| Tetryl | 1.30 | 1.70 (?) |
| TNT | 1.56 | 0.60 |
| TNT | 1.29 | 0.20 |

Note: The question mark is ours

In ProgrRept Oct-Dec 1950 are given relative luminosities of unshathed expls: PETN (of d 1.50) - 1.0, Comb C-4 (plastic) - 3.0

In ProgrRepts Jan 1951 to Oct 1952 no work on luminosity was described

In ProgrRepts Oct-Dec 1952 & Jan-March 1953, it was stated that much of the luminosity which accompanies deton is due to the shock wave in the ambient medium. The use of certain surrounds (such as propane) eliminates or substantially reduces these luminosities which are undesirable if one is attempting to observe the radiation emitted by the deton products in the deton wave

It was found during studies that side views of unconfined cylindrical chges of high d (1.6 g/cc) Tetryl obtd during deton by the image-converter camera with exposure time of 0.2 microsec or less showed practically no outward luminosity in the region of the deton zone. Since it is known that the deton front has a curved profile somewhat as shown in Fig 3 it was decided that the luminosity was hidden by the protruding rim of unexploded material. To overcome this obstruction a strip of transparent polymethyl

methacrylate was inserted flush with the cylindrical surface of the charge and the image-converter camera photographs were taken before the deton front entered this "windowed" zone. The Fig 1b of Oct-Dec 1952 ProgrRept, taken at a position about halfway down the "window", showed a brilliant luminous zone which originated from deton front. As this front passed rapidly thru the field of vision in side view, the sensing equipment would require an inconveniently short response time. To reduce this requirement, other geometrical setups were studied. Among these was the "probe rod" system in which a protruding transparent plastic rod was inserted into a cavity along the axis of the chge. It was assumed that, as the deton wave passes thru the part of the chge contg the rod, light originating from the deton products is piped thru the rod and can thus be observed at the rod end during the time it takes for the deton front to travel along the rod which is 1 cm or more long. This would greatly reduce the high-frequency response requirements of the sensing apparatus

In order to study means of suppressing shock-wave luminosity in the ambient medium, tests were made with Tetryl chges of d's 1.4 & 1.6 g/cc surrounded by air, propane and water. The Figs 2 & 3 of the Oct-Dec 1952 rept showed that propane and water surrounds effectively eliminated the shock wave luminosity (Figs are not shown here)

As the "ionic" front of the deton wave is frequently used for synchronizing and measuring equipment with exploding chges, probes were introduced into the chges for the purpose of supplying pulses to associated circuits. These probes were activated by the conductivity of the ions present in the deton zone. In order to establish the position of the ionic front with respect to the deton front, a method was devised in which the ionic zone could be made luminous by the passage of an electrical current thru

the deton zone and photographed by an image converter camera technique. An energy source consisting of a 2 mfd capacitor charged to 15 kv with an associated hydrogen thyratron as a switch was connected to two diametrically opposite discharge electrodes on the chge exterior. The test setup which included two Tetryl pellets of d 1.6, one hollow booster pellet, and a detonator is shown in Fig 4a of the Oct-Dec 1952 rept. It shows the image converter camera photograph of a portion of the chge before deton and Fig 4c the 0.1 microsec photo of the same chge portion during deton

ProgrRept April-June 1953. It was stated in previous repts that it might be possible to observe the luminosity of a deton wave by means of a transparent rod which is inserted into a cavity along the axis of the chge. In order to test this method, "end-on-streak" photographs were made of the light emitted during deton from axial holes in Tetryl chges, with or without inserted plastic rods. For this purpose the image converter camera was adapted to streak photography. An image deflection system, composed of a coil, current pulse generator and synchronizer, was constructed, and a variable-width slit placed in the focal plane of the field lens. An auxiliary lens formed an image of the slit on the photocathode deposit within the image converter tube. The shots in air w/o plastic rod showed strong radiation from the cavity at the moment of deton break-thru at the cavity base, with luminous zones resulting from strong shock-wave reinforcement as the deton progressed to the end of the chge, at which point an expanding shock wave emerged into the air surround. However, the luminosity from the cavity of a chge that had been impregnated with propane and fired in a propane-filled transparent container showed relatively weak light emission from the wall of the chge cavity as the deton progressed down and off the end of the chge. This test showed no radiation whatsoever at points of the cavity where abnormally high pressures should exist, indicating that propane effectively quenched the luminosity even under such extreme conditions

Comparison of the luminosity produced from the end of the plastic rod during deton showed the air-filled chges to be slightly more luminous than the propane-impregnated, propane-surrounded rod shots during the transit period along the wall, with a predominantly greater luminosity at break-thru (i.e. at the moment at which the deton wave reached the embedded rod). From the streak photographs of the propane shots with rod inserts, it could be assumed that the luminosities due to the shock wave in the plastic proper were nil, since there was a sharp cutoff in the streak produced when the deton reached the end of the chge, even though the rod extended beyond the chge

Sample pellets were prepd for luminosity studies to determine the feasibility of embedding axial plastic rods into cylindrical Tetryl pellets during the pressing operation. The method was successful up to a loading d 1.55, but cracking of rods occurred above this density

In ProgrRept No 10 (Ref 6) luminosity time tests employing a wide band Tektronix 517 oscillograph and frequency compensated photomultiplier anode circuitry are briefly described. Fig 2 of the rept (reproduced here as Fig 5) shows radiation luminosity waveform from a stepped rod of Tetryl. The work was continued and briefly described in ProgrRepts Nos 11 & 12 (Ref 6). The results of this work was used for determination of temperatures of detonation [See Detonation (and Explosion), Temperature Developed on]

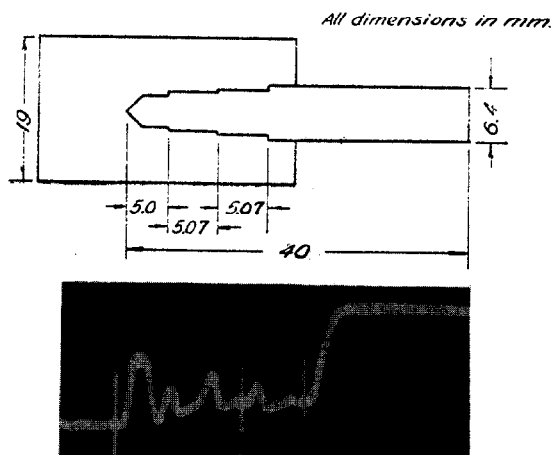
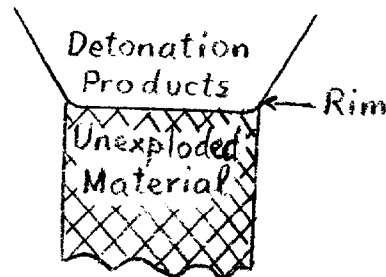

Fig 5 of Progr Rept No 10

Campbell et al (Ref 8) reported that rotating mirror camera of detonating liquids revealed regions of low luminosity called *dark waves*. These were observed in detonation of Nitromethane, of a solution 84/16-NM/Acetone (by volume) in DEGDN, Ethyl Nitrate and in single crystals of PETN. "Dark waves" originated at the glass tube walls and advanced into detonating liquids. Although these waves are larger and more numerous under conditions close to failure in detonation, they have also been observed under conditions in which the detonation is proceeding at normal, constant velocity. The authors suggested that the "dark waves" are closely associated with hydrodynamic rarefaction originating at charge boundaries. Dark waves could be eliminated by the use of thin metal foils, such as 0.001-0.002 inch thick tungsten, "Dural" or stainless steel, placed on the outside of glass containers. It was observed also that these foils can considerably reduce the diameter at which the failure of detonation occurs (Ref 13, p 202)

Sultanoff (Ref 9), using high-speed photographic instrumentation, observed in detail the luminosity from exploding Pentolite charges and offered an overall model which included a "preliminary light", the "detonation front", a "dark space" and "luminous air shock". The "dark space" is considered of constant width and is independent of ambient atmosphere. It does not depend on light-gathering power or other instrumentation effects, is neither reflective nor transparent and, at the boundary air shock velocity, represents a time lapse of 0.5 microseconds. The front is preceded by a luminous band due to light scattered in the charge ahead of the detonation. The front connects continuously with the expanding envelope, but a lack of luminosity is observed at the charge-air boundary which extends out from the charge and accounts for the "dark space". The latter is followed by the highly luminous products which terminate in the luminous expanding shock envelope (See also Ref 13, p 176)



Hinz & Wenig (Ref 10) observed "back-lighting" in the shock around a moving explosive charge

Holland et al (Ref 11) reported that when single crystals of PETN were initiated by means of a charge of Comp B, the velocity started at 5560 m/sec and then suddenly changed to 10450 while accompanied by observable radiation in the interior of the crystal. Then a final, apparently steady velocity was established at 8280 m/sec. The "dark waves" observed in detonation of single crystals of PETN arose at the periphery of the detonation wave and preceded failures of the detonation process. In a typical experiment a rod of PETN of diameter 0.252 inch and 0.438 inch long was wrapped with brass foil for a distance of 0.287 inch from the boosted end. The foil seemed to prevent the occurrence of dark waves in the first part of the stick, but when the detonation wave passed the foil, it was choked off by dark waves (See also Ref 13, p 202)

Poulter (Ref 12) observed effects similar to those of Ref 11 and concluded that the action of foil was not due to confinement since the foil was too thin to provide such confinement. He suggested rather that the propagation of detonation was assisted by radiation, reflected from the inside surface of the foil, which otherwise would be lost (See also Ref 13, p 202)

Dunkle reviewed the literature on luminosity and gave brief resumés of publications on pages indicated here under Ref 13

Cook (Ref 14): p 97 described "striations in luminosity"; pp 150-53, ionization and luminosity zones in gaseous detons; p 155, Fig 7.5c showed streak camera luminosity trace in pressed salt from end of 5-cm Comp B; p 158, Fig 7.6 gave framing camera sequence of air shock wave and beyond a glass tube (produced by 75/25-Concd HNO₃/Nitrobenzene) showing luminosity due to electron recombination in plasma; p 170, Fig 7.10 gave streak photograph of luminosity due to heat pulse in Comp B; pp 183-86, Figs 8.6, 8.7, 8.8 & 8.9 showed streak-camera photographs of luminosities produced on transition from deflagration to detonation in gaseous expls; p 189, Fig 8.11 showed luminosity produced by SPHF (Shock-Pass-Heat-Filter) initiation of Comp B; and p 192, Fig 8.14 showed luminosity produced by SPHF initiation of Dithekite 13

Cook (Ref 15) also reported that the shock transmitted thru a barrier into a transparent liq expl, appeared (from the partial opacity of the liq behind the shock front) to initiate some reaction at once. The high-velocity deton appeared, on the other hand, to start as a much more intense luminosity at one or more centers randomly distributed within the reacting liq. Often an intense flame is observed to flash across the region just traversed by the shock wave, at a velocity far above the normal deton vel, and upon reaching the shock front to start a high-order deton (See also Ref 17, p 13b)

Woodhead (Ref 16) reported in the paper entitled "Advance Detonation in Tubular Charge of Explosive", that a deton proceeding axially within the wall of a hollow tube of HE had a rate higher than normal by several hundred cm/sec and was, itself, outdistanced by a luminous wave within the hollow. This luminous wave moved at almost twice the deton vel. When the far end of the tube was closed with a plug of HE the luminous wave initiated on striking

the plug a deton ahead of the main deton front, called an *advance detonation* (See Vol 1 of Encycl, p A105-R). Its collision with the main deton front and with the luminous shock front in the cavity produced strong visible radiation and a pressure peak (See also Ref 17, p 17e)

Dunkle (Ref 17) reviews the literature on luminosity and radiation from 1958 to 1960 incl. Some of these papers describe detn of temperature developed on detonation, others deal with "plasma" phenomena [See also under Detonation (and Explosion), Temperature Developed on and also under Detonation and Plasma Phenomenon]

Gibson et al (Ref 18, p 4) conducted investigation of detonation and combustion events employing streak cameras. Such photographs portrayed, except in the case of transparent liquids, the luminous phenomena that occur on the periphery of the expl chge or proplnt strand. Since the primary locus of initiation and growth of the reaction can be well within the material, a method for sensing luminous precursor events in the opaque chge core was devised. This method involved placing a transparent wafer longitudinally into the chge; the image of the edge of the wafer was focused on the streak camera slit where the wave image width is greater than the slit width so that only luminosity in the wafer entered the camera. Two configurations using glass wafers were evaluated: 1) A wafer passing diametrically thru the strand or grain and 2) A wafer extending radially from the chge core. In the latter case, propane was passed thru an axial port to attenuate shock wave luminosity at the wafer-edge explosive interface. The system and typical streak photographic records are shown in Figs 6 & 7 of the report. They are reproduced here but without streak photographs. Fig 6 shows the position of a 0.060 in. thick glass wafer passing thru a Terry l chge of d 1.62 g/cc. The glass edge was imaged on the camera slit. Fig 7 represents a setup similar to Fig 6 except that the wafer passed only to the chge core. An axial void was provided betw the expl and the glass wafer. During

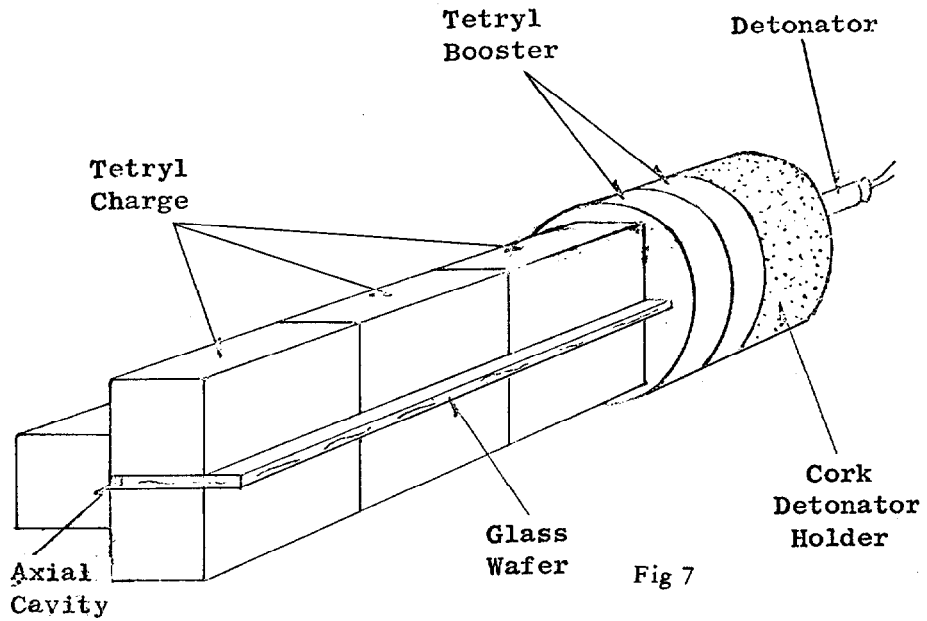
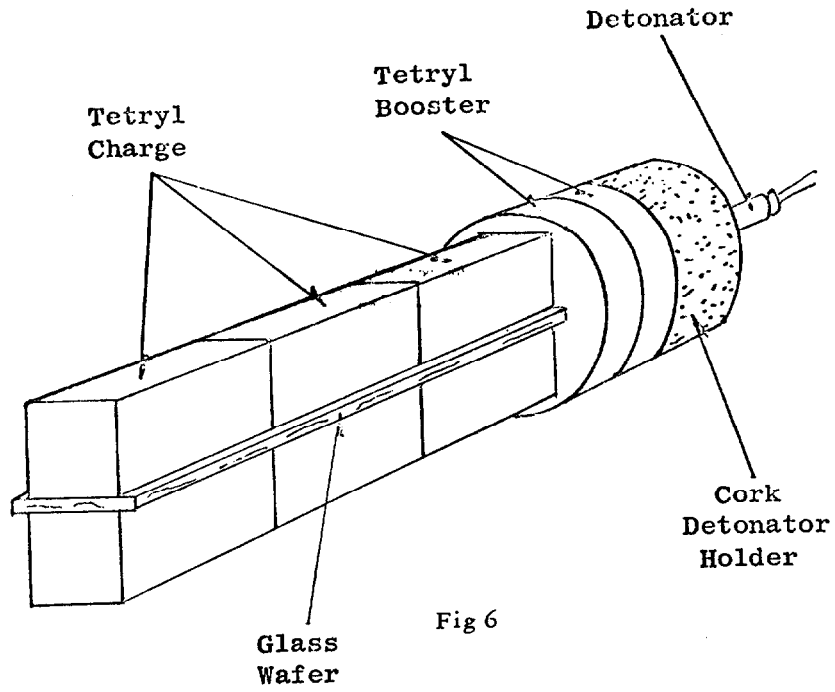

the test propane was passed thru the void to minimize shock luminosity. The chge was composite, consisting of Tetryl pellets having a square cross section

The least ambiguity is found in the diametric wafer system since considerable shock luminosity is associated with the deton when the radial wafer is used, despite the presence of propane

Johansson (Ref 19) described emission of light by brisant expls
Refs: 1) D. Mitchell & S. Paterson, *Nature* **160**, 438 (1947) 2) G. Herzberg & G.R. Walker, *Nature* **161**, 647 (1948) 3) H. Muraour, *MAF* **23**, 867 (1949) 4) C.M. Mason et al, "The Physics and Chemistry of Explosives Phenomena", USBurMines, Pittsburgh, Pa, ProgressReports from April 1948 to June 1951, Contract NA onr 29-48, Project NR 053 047; *Ibid*, ProgrRepts July 1951 to June 1952, Contr NA onr 29-48, Proj 357 047; *Ibid*, ProgrRepts July 1952 to June 1953, OrdnProj TA3-5001 5) Taylor (1952), 30-2, 154-55 & 173-74 6) C.M. Mason & F.C. Gibson, "Research Program on Detonation and Explosives Phenomena", USBurMines, Pittsburgh, Pa, ProgrRept No 10, Oct 1, 1955 to Dec 31, 1955 and ProgrRepts Nos 11 & 12, Jan 1, 1956 to June 30, 1956, Army Project 504-01-015, OrdnCorpsProj TA3-5101 7) M. Birk et al, *MP* **36**, 129-32 (1954) & *CA* **50**, 2979 (1956) 8) A.W. Campbell et al, *Nature* **178**, 38-9 (1956) & *CA* **51**, 11718 (1957) 9) M. Sultanoff, BRL Rept **987** (1956) 10) D.J. Hinz & J. Wenig, BRL Memo **1110** (1957) 10a) R.R. John & M. Summerfield, *JetPropulsion* **27**, 169-175 & 178 (1957) (Effect of turbulence on flame radiation) (Authors measured the radiation intensity from propane flames and found a decrease in radiation with turbulence. Radiation is not thermal, but appears to be a luminescent phenomenon) 11) T.E. Holland et al, *JApplPhys* **28**, 1217 (1957) 12) T.C. Poulter, Stanford Research Institute, SRI PoulterLabsTechRept **010-57** (1957) (Unclassified paper, pp 83-92) 13) Dunkle's Syllabus (1957-1958), pp 115-19 (Laminar & turbulent burning); 130 (Radiation transients); 176 (Discussion of

Sultanoff's work on luminosity); 202 (Discussion on "dark waves and observable" radiation in the interior of the crystal); 281 (Discussion on works of Walker & Poulter on luminosity); 305-06 (Detn of temp by radiation and spectra methods); 384 (Discussion on work done at PicArnsn on radiation of pyrotechnic compns); 386 (Effect of radiation from a shock wave in an atmosphere at ordinary pressure is negligible in comparison to an endothermic reaction capable of absorbing thousands of kcal per kg of air at 10000°K); 396 (Discussion on energy loss by radiation from the body of the gas mainly in the form "Bremsstrahlung" produced when electrons are deflected by ions); 398, 400, 401 & 403 (More discussion on radiation) 14) Cook (1958), 97, 150-53, 155 & 158 15) M.A. Cook et al, *PrRoySoc* **246A**, 283 (1958) 16) D.M. Woodhead, *Nature* **183**, 1756-57 (1959) 16a) I.M. Voskoboinikov & A.Ya. Apin, *DoklAkadN* **130**, 804-06 (1960) (Determination of detonation-front temperatures using the luminosity method); En gl translation OTIA 8500, OTS 60-41489 16b) J. Herschowitz et al, "Combustion in Loose Granular Mixtures of Potassium Perchlorate and Aluminum", pp 720-27 in the *8thSympCombstn* (1960) (Discussion on radiation observed during combustion) 17) Dunkle's Syllabus (1960-1961), p 7c (Luminosity of Ar & Xe); 10c (Luminous zones & laminar flame); 10d (Ionization potentials measured by Watanabe); 13b (In the combstn of loose granular mixts of $KClO_4$ & Al a "luminous precursor" precedes the main combustion front); 14f (Plasma); 14g (Occurrence of electromagnetic processes); 17e (Discussion on luminous wave within the hollow and on advance detonation; 24b & 24c (Discussion on plasma and on highly luminous region which separates from deton products); 24f (Some refs on Plasma) 18) F.C. Gibson et al, "Studies on Deflagration to Detonation in Propellants and Explosives", USBurMinesSummaryReport No **3863** (1962), covering work done from Jan 1, 1959 to Dec 31, 1961. This includes ProgressReports and AnnualSummaryReport No **3769** (1959)

[The work on luminosity is described also under Detonation (and Explosion) Temperature of] 19) C.H. Johansson, *Explosivst* **11**, 251-61 (1963) & *CA* **66**, 474 (1967) (Emission of light in detonation of HE's) 19a) G.S. Sosnova et al, *DoklAkadN* **149**, 642-3 (1963) & *CA* **59**, 375-76 (1963) (Light emission by a low-velocity detonation front in NG) 20) Per-Anders Persson et al, "A Technique for Detailed Time-Resolved Radiation Measurements in the Reaction Zone of Condensed Explosives", 4thONRSympDeton (1965), pp 602-08 (1960) (A fast photomultiplier and high-speed oscilloscope are used to record intensity of the light emitted from within the reaction zone in some condensed explosives) 21) C.G. Dunkle, private communication, January, 1968 22) M. Maesawa et al, "Radiation from the Luminous Flames of Liquid Fuel Jets in a Combustion Chamber", 12thSympCombstn (1969), pp 1229-37

Detonation, Mach Number in. Mach (pronounced as Makh) Number, designated as M or M_0 , is the ratio of the shock velocity to the sonic velocity and for an ideal gas may be expressed as:

$$M^2 = 1 + \frac{(p - p_0)}{p_0} \frac{(j+1)}{2j}$$

where (p_0) = pressure of undisturbed air or other gas; (p) - peak pressure of shock wave; $(p - p_0)$ - pressure discontinuity; and (j) - specific heat ratio at constant pressure to that at constant volume C_p/C_v (Ref 1)

Designating Mach Number as M_0 , Dunkle gave the following equation:

$$M_0^2 = 1 + \frac{\gamma+1}{2\gamma} \frac{P - P_0}{P_0} = \frac{(\gamma+1)P + (\gamma-1)P_0}{2\gamma P_0}$$

where (γ) is C_p/C_v , same as (j) in the 1st formula, and (P_0) and (P) correspond to (p_0) and (p)

Refs: 1) C.G. Dunkle, "Introduction to Theory of Detonation of Explosives", Lecture delivered at PicArns on Dec 13, 1955, p 7 2) Dunkle's Syllabus (1957-1958), p 66, Equations 103a and 103c

Detonation, Mach Reflection and Mach Region. See under Detonation, Mach Wave, etc

Detonation, Mach Wave; Mach Reflection; Triple Point; and Mach Region

Formation of Mach wave from a spherical wave produced on detonation of an aerial bomb was briefly discussed in Vol 2 of *Encycl*, pp B182 ff, under BLAST EFFECTS IN AIR, EARTH AND WATER. The Fig on p B183 illustrated the formation of Mach wave and showed the pass of the "triple point"

Argous et al (Ref 7, p 135) give the following comprehensive description of the formation of Mach detonation waves:

"It is generally agreed that a detonation wave consists of a shock wave which propagates in the explosive, followed by a zone of finite dimension in which the chemical reaction initiated by the shock front provides the necessary energy to maintain the shock wave. If the initiating shock front possesses a vertex point of suitable angle, a Mach wave will be created in the interior of the explosive and chemical reactions will develop in a region that is more compressed than would be the case for a normal shock front. There is reason to believe that the hydrodynamic detonation parameters, velocity D , and pressure p , will therefore be of greater magnitude in the zone covered by the Mach wave than in a region of a normal detonation wave. This particular and localized detonation wave constitutes a Mach detonation wave"

A detailed description of three exptl procedures in which formation of Mach waves was observed is given on pp 135-41 of the above paper

The following description of formation of Mach waves is given in Ref 1, pp 74-5; Ref 2, pp 91-2 & 315; and Ref 9, pp 5-26 & 5-27

When a shock or blast wave strikes a solid surface at a small angle of incidence, α (say ca 30°), a reflection, known as "regular reflection" takes place (See Fig, which is reproduced from Ref 1, p 75). If

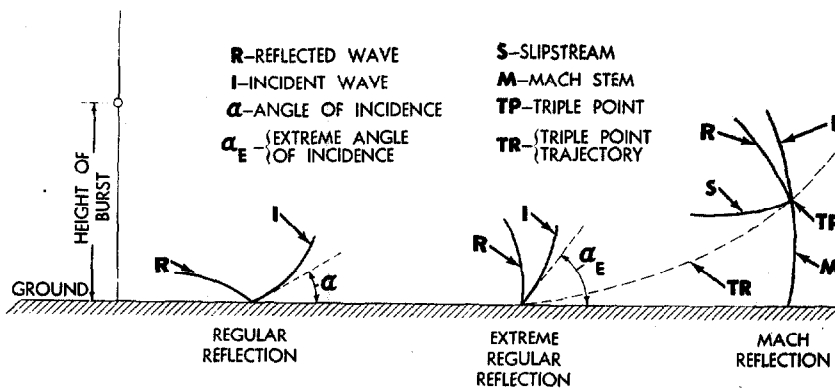

Fig Mach Reflection of Shock Wave

the angle of incidence is greater than a so-called "extreme angle" (40° for strong to a value approaching 90° for very weak shocks), the irregular or *Mach reflection* results. If the angle of incidence is between regular and extreme, the so-called "extreme regular reflection" takes place

In the so-called *Mach reflection*, the incident and reflected waves do not intersect on the ground but at some point above the ground. The lower portions of the incident and reflected waves fuse into one wave which is known as the *Mach stem*, M, (also known as *Mach shock* or *Mach bridge*). The point of intersection of I, R & M is known as the *triple point*, TP. The resulting existence of the above three waves, causes a density discontinuity. The surface of this discontinuity, known as *slipstream*, S, represents a stream line for the flow relative to the intersection. Between this and the reflecting surface is the region of high pressure, known as *Mach region*; here the pressure is approx twice that behind the incident wave. The top of this pressure region, the triple point, travels away from the reflected surface. As pressure and impulse appear to have their maximum values just above and below the triple point, respectively, the region of maximum blast effect is approximately that of the triple point

Spark photography with shadowgraph, schlieren and interferometer techniques (such as described in Vol 2 of Encycl, under CAMERAS) showed that density is uniform in zones I-TP-M and I-TP-R, but not in the zone R-TP-M, which includes the Mach region. The Mach shock M appears to be followed by rarefaction. Above the slipstream there is an angular variation of density so that, if measured at points farther and farther behind R, the density first rises to a maximum and then falls again

For more detailed description of Mach waves etc, see Refs 2a, 3, 4, 5, 6, 7 and 8
 Refs: 1) Anon, "Military Explosives", TM9-1910(1955), pp 74-5 2) Dunkle's Sullabus (1957-1958), pp 91-2 & 315
 2a) Baum, Stanyukovich & Shekhter (1959), p 327 (Volna Makha) 3) J. Sternberg, "Triple Shock Intersections", Physics of Fluids 2(2), 179-206(1959) 4) E.A. Feoktistova, "Experimental Observation of Mach Reflection of Detonation Waves in Solid Explosives", Sov Physics - Doklady 6(2), 162-63(1961) (Translated from Russian)
 5) B.B. Dunne, "Mach Reflection of Detonation Waves in Condensed High Explosives I", Physics of Fluids 4(7), 918-24(1961)
 6) Ibid, Part II, Physics of Fluids 7(10), 1707-12(1964) 7) J.P. Argous et al, "Observation and Study of the Conditions for Formation of Mach Detonation Waves", 4thONRSympDeton (1965), pp 135-41

8) B.D. Lambourn & P.W. Wright, "Mach Interaction of Two Plane Detonation Waves", *Ibid*, pp 142-51 9) Anon, "Military Explosives", **TM9-1300-214** and **TO 11A-1-34** (1967), 5-26 11) 12th Symp Combstn (1968) (Pub 1969). No papers on Mach waves

Detonation (and Explosion), Magnetic Effects Accompanying It. See under Detonation (and Explosion), Electrical, Electromagnetic and Magnetic Effects Accompanying It

Detonation, MASER and LASER in.

The term MASER stands for **Microwave Amplification by Stimulated Emission Radiation**

The term LASER stands for **Light Amplification by Stimulated Emission Radiation**

Both processes involve the generation of radiation which is unidirectional, highly monochromatic and coherent. The latter feature describes the in-phase nature of the wavelets and, hence the high intensities that can be achieved with solid lasers

The emitted radiation results from a "pumping" of particular chemical systems with white light. This raises a majority of "active" species in a "lasing" system to a particular metastable excited state from which they are stimulated to simultaneously drop to ground state. The resulting radiation is in the microwave region in the case of MASER and in the visible region in the case of LASER. Since a solid laser can produce light of high intensity, it has been employed as a source for initiating explosive reactions (Ref 13)

Accdg to the description given in "Time" magazine (Ref 11, pp 42-9), physicists A. Schawlow & C. Townes described in 1958 a device that they thought would be able to stimulate molecules of gas confined in a cylinder until they gave off photons (basic unit of light) in an intense and powerful stream. Their device was a variation of Townes' earlier Nobel prizewinning invention named MASER. Because their

device was designed to produce visible light it was proposed to call it an "Optical MASER". The first working model of this device was built in 1960 by physicist Maiman who named it "Ruby LASER" (See Fig), because it used a synthetic ruby crystal rod for emission of light (instead of gas used in MASERS). The color of light was red and it was shot in bursts. A brief description of this device is given in Ref 11, pp 42-9

Unlike ordinary white light which is a mixture of all colors, and thus of many wave lengths traveling in divergent directions, Laser light is "coherent". It emerges from the rod in rays which are parallel, is all of the same wave length and in a phase (or in step), each ray reinforcing the others. It is these coherent qualities that make Laser light so narrow-beamed, so easy to focus and so powerful. Laser light can be focused into a spot with a diam of only 1/10000th of a cm. Concentrated into such a small area, it burns billions of times brighter than the sun's surface. It cannot, however, penetrate fog, clouds or other opaque objects

Since Maiman's "RUBY LASER", many other substances [gases, liquids and solids (such as glass, plastics)] were found capable to "lase" - some by intense flashes of light, some by high voltage discharges, others by injection of streams of electrons. A LASER beam can now be produced continuously or in pulses and in colors ranging from orange to blue and invisible infra-red

Continuous Lasers are used for communications, while pulsating ones for drilling, welding, and in surgery. Infra-red devices are used for military purposes, such as for night-fire surveillance from aircraft and for bomb warheads that seek out targets illuminated by IR LASER beams. Some military uses of LASER beams are briefly described under Refs 6, 7 & 12

It is expected that some day LASER beams will be powerful enough to be used as "death-rays" and also to be used against missiles by heating them to melting point of metal

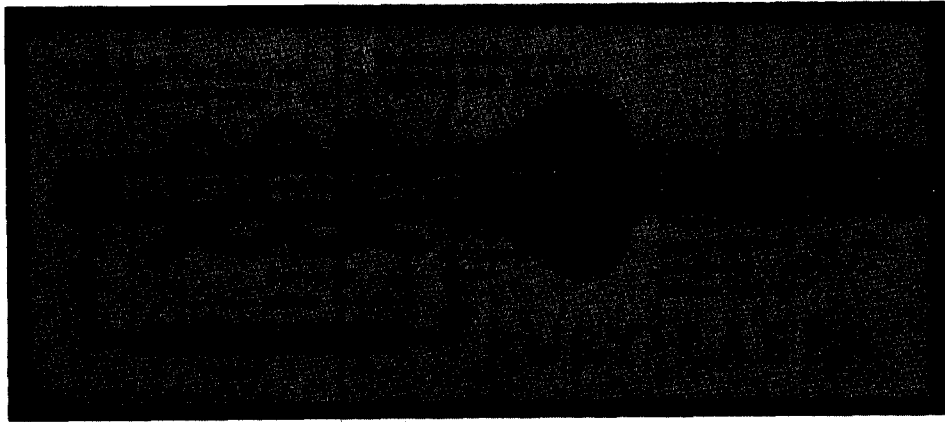

A brief description of recent LASER devices is given in Refs 8, 9 & 11

Addnl information on Masers can be obtained from Refs 1 & 3 and on Lasers from Refs 2, 3, 4 & 5

- Refs: 1) A.A. Vuysteke, "Elements of Maser Theory", VanNostrand, NY (1960)
 2) D.G. Grant, "Principles of Laser Operation", APL/JHU CF-2974, March 15, 1962
 3) H.A. Klein, "Masers and Lasers", Lippincott, Philadelphia & New York (1963)
 4) S. A. Ramsden & P. Savic, "A Radiation Model for the Development of Laser-Induced Spark in Air", Nature **203**, 1217-19 (1964) (Reprint of National Research Council of Canada, Ottawa, Ontario) (In the course of recent work on the spark produced in air by a focused ruby laser beam, the rather surprising result was obtained that, after breakdown, the spark envelope developed asymmetrically, moving toward the lens with an initial velocity of about 10^7 cm/sec. This effect is discussed in terms of a new mechanism, that of a *radiation-supported shock wave*. It is assumed that after breakdown a shock wave propagates into the undisturbed gas, and that further absorption of energy from the laser beam then occurs behind the shock front traveling toward the lens, in the manner of a detonation wave. After the end of the laser pulse the heated gas then expands in the form of a blast wave) [Abstract supplied by Dunkle (Ref 10)]
 5) Staff Article in Chem & Engrg News,

Feb 8, 1965, pp 40-2: "Chemical Laser Efforts Broaden Scope of Laser Research"

- 6) A.A. Brish et al, Fizika Goreniya i Vzryva **1966**(3), 132-33 & CA **66**, 6373 (1967) (Initiation of detonation in condensed explosives, such as LA & PETN, by laser-emission) 7) A.K. Oppenheim et al, PrRoySoc **291A**, 279 (1966) and P.A. Urtiev & A.K. Oppenheim, 11th Symp Combstn (1967), p 665 (Study of detonative ignition induced by shock wave, using stroboscopically operating LASER light source and rotating mirror camera producing a framing speed of 200 photographs per millisecond) 8) Anon, "What's New in Laser", Ordn **53**, July-August 1968, pp 88 & 90 [An exptl Laser system using a circulating liquid as the light producing material has been developed at the General Telephone and Electronics Laboratories, Inc and was believed to be the first successful application of a circulating rather than a stationary liquid. Its advantages over devices using stationary liquids are discussed. The circulating liquid consists of neodymium dissolved in an acidified soln of selenium oxychloride

The first Laser to operate at full span of MilSpec ambient temperatures has been possible by the use of thermal controllers constructed by the Astro Dynamics, Inc for Hughes Aircraft Co's Laser system. The system will allow increased power to present Laser flash-tube models without fear of chem breakdown or double-pulsing. It also will

allow operation at temps between -200° to $+500^{\circ}$ F with full optical clarity thruout the range

An experimental "Laser-pump" using a "ball of light" to bathe a Laser rod from all directions has been developed at the Westinghouse Research Laboratories. In this device the Laser rod and lamp are placed along the center of a hollow spherical reflector, the entire inside surface of which is reflecting

A portable neodymium Laser has been produced by the Photon Systems Department of Space Ordnance Systems, Inc, El Segundo, California. This device named "Macro-Pak" is claimed by the Co as a break-through in both size and simplicity and provides a truly portable working Laser-head and power supply. The device is only 140 cu inches in size and weighs 6 lbs. It emits a wave length of 1.06 microns, producing a maximum output of 5 joules]

9) American Optical Co, Space-Defense Division, Laser Products Department, South-bridge, Mass, 01550, announced in their "News Release", published in 1968, the development of "UNI-LASER", claimed to be "the lowest cost - longest operating life - most practical compact pulsed laser". Typical tests have produced output energies in excess of 1 joule with operating lifetime of more than 100000 firings to one half of the initial output. The same Co produced "UNI-LASER-POWER SUPPLY"

10) C.G. Dunkle, private communication, July 4, 1968 11) Anon, "Light Amplification by Stimulated Emission of Radiation", Time, July 12, 1968, pp 42-9 12) Anon, "Laser Rangefinders for Tanks", Ordn 53, Jan-Feb 1969, pp 430-31 (In operation, the rangefinder device bounces a ray of laser light off a target and determines the range by measuring the time needed for the ray to reach the target and reflect back. In the M60A1E2 tank rangefinder, the laser is bore-sighted with the tank commander's sight on the gun. When the laser flashes at a target, range appears in meters on a readout and also is fed automatically into the tank's fire control system. The Army's Frankford Arsenal, Philadelphia, Pa has

awarded Hughes Aircraft Co a 2.7 million contract to supply 243 rangefinders for the tank M60A1E2. The newer Main Battle Tank MBT-70 also will have a similar rangefinder) 13) Jack Alster, PicArns, Dover, N J; private communication, March, 1969

NOTE: Masers and Lasers, Remarks of C.G. Dunkle

Laser operation is based on the process of *population inversion* by *optical pumping** with intense light. The frequency must be high enough to raise an array of atoms to a higher energy level, and the light must be intense enough to invert the normal order of smaller population at higher energy level. Then an initially weak photon beam signal, of frequency corresponding to the inter-level energy, will on traversing the array (*amplifier cavity*) encounter more emission centers than absorption centers and thus be *amplified*

The *gain* (Ref 1, pp 12-13) is a function of the frequency corresponding to the inter-level energy difference, and increases exponentially with lengthening of the cavity, with increase in the number of active atoms (density) in it, and with decrease in the temperature

The cavity can be provided with the proper feedback to become an *oscillator* (Ref 1, p 4). This is achieved with highly reflective parallel flat plates at both ends of the cavity. One mirror may transmit slightly so as to provide an output path. The photon beam is repeatedly reflected, gaining in energy with each traversal. The resultant beam has important properties because it is highly unidirectional, of high energy, and *coherent*, i.e., with wave front parallel to the plates, although the light traversing different filaments of the crystal may differ in phase

Coherence is difficult to explain and has been identified with monochromaticity, a term applying to radiation of only one color or frequency. This can be considered *coherence in time*. *Coherence in space*,

*Optical pumping lifts many molecules from the ground state to the excited state so that the latter becomes occupied by more molecules than the ground state. This is referred to as population inversion.

in which the waves are not only monochromatic and unidirectional but identical in phase, (Ref 2, pp 4-5) is more difficult to achieve in practice

A serious drawback of the *ruby laser* (the form developed by Maiman at Hughes Aircraft) is the need for a pump light of very strong output in the the ruby absorption bands, 4100 and 5100Å. Most light sources sufficiently intense at these wavelengths to cause population inversion are broad-band devices and therefore inefficient for the purpose. Typical input energies to the pumplight (Xe flash tube) range from several hundred to several thousand joules. The most difficult problem in the development of this laser, therefore, has been to achieve CW (*continuous-wave*) operation. The high input energies required for inversion lower the efficiency and cause severe heating problems in the crystal

Distinguishing laser features are:

(a) *High power and short duration.*

Outputs are in the megawatt range. Single pulses as short as 10^{-8} second have been generated at power levels of over 10 million watts. One watt-second, about the output of a flashlight bulb operating for 2 seconds, can vaporize a hole completely thru a razor blade if delivered as a short enough pulse. There seems to be no basic limit to the power that can be generated

(b) *Small spot focus (narrow beam width).* The laser beam can be focused to an area of the order of 1 micron. The laser output can be focused into a beam about one thousandth as wide as those of most "narrow-beam" radars. Focusing with a small lens system can give a 1-second beam width, making a spot on the surface of the moon slightly wider than a mile. Laser light reflected from the moon was detected in 1962 (Ref 3)

CW operation of a ruby laser was achieved in early 1962 for the first time, at Bell Telephone Laboratories (Ref 1, p 14). Gas phase lasers had previously operated continuously, but these deliver only 3 milliwatts (Ref 2, p 16) as against 1 watt from solid-state CW lasers. Bell scientists revealed five new

gaseous lasers, each using a single *noble gas*, which provided a total of 14 new frequencies of coherent light (Ref 4)

The high radiation intensity required for inversion is characteristic of most laser material pumped from the *ground state*. There are crystals which work between intermediate levels so that the pump intensity requirement is less severe, e.g., CaF_2 with U doping (developed by IBM in 1960) or Sa. By the end of 1962, Bell Labs used a crystal rod of CaWO_4 doped with trivalent Nd to produce a *continuous wave solid-state laser*.

Also during 1962, *modulation* of a laser output was achieved by GE and IBM (Ref 4, p 52). Such modulation is the key to communication by *light beams*. Visible radiations have such high frequencies, a billion times those of radio signals, that a bandwidth modulation of only 0.1% would be adequate. This in theory would allow transmission of more than 100 million telephone conversations at once over a single light beam. Also, since laser light frequency is about 10000 times that seen by a high-frequency microwave radar, lasers should be that much more precise in velocity measurements by doppler shift.

In 1962, two new types of laser were announced. One, in which an electric current passing *through a semiconductor* generates an intense beam of light, was developed at several laboratories, and continuous operation was achieved. In the other type, reported from the research laboratories of Hughes Aircraft Company at Malibu, California, *liquid organic compounds* such as benzene, nitrobenzene, 1-bromonaphthalene, pyridine, cyclohexane, and deuterated benzene are used for laser action (Ref 4, p 53). These lasers emit coherent light at 13 previously unavailable wave lengths, mostly in the near IR, and operate on a previously unused principle, *stimulated Raman scattering*. In the ordinary Raman effect, outgoing or scattered light differs in energy and therefore in wavelength from the incoming light; the difference results from a conversion to molecular vibration energy (Ref 5)

In these new laser materials, unlike all others, there is *no upper energy level* involved; no initial excitation to upper energy levels is required. However, very strong incident or "pumping" light is needed to initiate laser action. Such pumping can be provided with a high-power, short-pulse ruby laser (Ref 6)

Obvious future applications to weaponry follow from the output of high powers at narrow beamwidths. Even the 50-watt-second laser could have its radiation detected at a distance of 30 billion miles with only a 3-inch-diameter lens (Ref 2, p 14). Since even here the signal-to-noise ratio would be 10, the detection process would be very clean. In a pulse of 200 microseconds with a beam width of 1 second, this laser would *ignite wood and paper* at a distance of about 1 mile

Refs: 1) D.G. Grant, APL/JHU CF-2974, 15 March 1962, "Principles of Laser Operation" 2) Raytheon Company, "Principles and Applications of Lasers". A Presentation before the New York Society of Security Analysts, May 8, 1962 3) "1962 Science Review", Science News Letter for December 22, 1962, p 400 4) "Lasers Attract Chemical Interest", Chemical and Engineering News, December 31, 1962, pp 52-3 5) "New Laser Uses Liquid", Science News Letter for December 15, 1962, p 378 6) G. Eckhardt et al, Physical Review Letters, **9**, 455 (1962)

Addnl Refs: A) H. Stats & G.A. de Mars, "Quantum Electronics", C.H. Townes, Editor, Columbia University Press (1960) B) C.G. Klick & J.H. Schulman, "Luminescence in Solids", USNRL (Second Edition of Vol 5, Solid State Physics, edited by F. Seitz & D. Turnbull, Academic Press (1957), p 106 C) Quantatron, Inc, Applied Physics Laboratories, Santa Monica, Calif, (Coherent Infrared Ranging System", 15 Mar 1962 (Second Quarterly Progress Report) D) F. Seitz, RevModPhys **26**, 7 (1954) E) A.A. Vuylsteke, "Elements of Maser Theory", VanNostrand, Princeton, NJ (1960) F) H.A. Klein, "Masers and Lasers", Lippincott Co, Phila and New York (1963) G) T.R. Carver, "Optical Pumping", Science **141**, No 3581, 599 (August 16, 1963) H) A.K. Levine, "Lasers", AmScientist, No 1, p 14 (March 1963)

NOTE: Chemical Lasers, Remarks of C.G. Dunkle

Jerome V.V. Kasper & Dr G.C. Pimentel of the University of California, Berkeley, reported laser emission in the infrared energized by the reaction: $H + Cl_2 \rightarrow HCl^* + Cl$. They fill a laser tube with a mixture containing 1 volume of Cl_2 and 2 volumes of H_2 , which is then exposed to the flash from a Xe-filled quartz flash tube. The resulting laser emission is centered near 3.8 microns in the IR

Dr C.K.N. Patel et al of Bell Telephone Laboratories achieved laser action in the IR by passing an electric discharge thru CO_2 and CO at very low pressure (about 0.2 torr). Continuous-wave laser action was obtained on a number of rotational transitions of a vibrational band of CO_2 , the strongest transition occurring at 10.6324 microns. More recently, Patel et al obtained laser action with mixtures of N_2 with CO_2 and with N_2O . Laser action was due to vibrational energy transfer from N_2

Population inversion was found in a C_2H_2/O_2 flame by Dr R. Bleckrode & Dr W.C. Nieuwpoort of Philips Research Laboratories, Eindhoven, the Netherlands. Part of the radiation from the reaction zone of this flame is nonthermal, being chemiluminescent in origin. In determination of populations of species such as C_2 and CH in low-pressure diffusion or premixed flames at 1-15 torr, these authors developed a simple model of a flame which reflects the characteristic requirements for start of laser action. They show that by choice of the proper experimental parameters in the model, laser action should be attainable

Dr Irwin Wieder, Dr R.R. Neiman & Dr A.P. Rodgers of Interphase Corporation-West, Palo Alto, Calif studied the IR and UV radiation emitted by excited species in *low-pressure gaseous C_2H_2/O_2 explosions* in order to establish the population distribution in selected energy levels. In the UV they used cavity techniques, and found a relative enhancement of several electronic transitions in CH and OH radicals. In the IR the emission from excited CO_2 molecules which form behind a fast detonation

wave gave evidence for an enhanced population of the high vibrational levels of CO₂
 Ref: "Chemical Laser Efforts Broaden Scope of Laser Research", (Staff article), C&ENews, Feb 8, 1965, pp 40-42

Detonation (and Explosion), Mechanical Effects of. These include *blast effects*, which are described in Vol 2 of Encycl, pp B180 ff and *shattering effect*, described in Vol 2, pp B265 ff, under BRISANCE. The latter effect causes *fragmentation* of bombs, shells, grenades, rockets, mines, torpedoes, etc

As an example of investigations of mechanical effects, may be mentioned that of Weibull(Ref). He detonated charges of expls in air and underwater in order to determine mechanical effects on surrounding media. He found that when the chge was exploded in air, the distribution of impulse around the charge depended on its form, whereas in underwater expls the impulse was distributed in the form of a circle and did not depend on the shape of the chge
 Ref: W. Weibull, MAF 22, 227-45 (1948)
 (Translated into French from Norwegian)

Detonation and Mechanical Properties of Rubber Bonded Sheet Explosives are discussed by W. Kegler & R. Schall in the 4thONRSympDeton (1965), pp 496-501

Detonation (and Explosion), Mechanisms of.

If all detonations were "ideal", their mechanisms would be the same as described in hydrothermodynamic theory of detonation. This mechanism is described by Cook (1958) in Chapter 4 entitled: "Thermohydrodynamic Theory and Mechanism of Detonation", pp 61-90. He also described the mechanism of detonation in University of Utah Technical Report No XLI, Nov 15, 1954

As the hydrothermodynamic theory sometimes does not agree with experimental data, some modifications have been proposed such as the theory proposed by A.Ya. Apin in 1940. This theory is described under "Detonation (and Explosion), Penetrating, or Jet-Piercing Theory of Apin"

Another theory was proposed by R. Carl in 1940. It is described under "Detonation (and Explosion), Breaking Theory of Carl"

For strictly "nonideal" detonation there exist the following approximate theories:

- 1) *Curved Front Theory of Eyring et al* [described under "Detonation (and Explosion), Curved Front Theory of Eyring et al"]
- 2) *Nozzle Theory of Jones* [described under Detonation (and Explosion), Nozzle Theory or Expanding Jet Theory of Jones] and
- 3) *Geometrical Model Theory of Cook* [described under Detonation (and Explosion), Geometrical Model Theory of Cook]

Detonation (and Explosion), Mechanism of Initiation and Propagation of. See under Detonation (and Explosion), Initiation (Birth) and Propagation (Growth or Spread) in Explosive Substances

Detonation (and Explosion) in Media of Variable Density. The study of this topic was conducted by some Rus scientists because it was considered that the problem has an application on the cosmic scale such as in explosions (evidenced by flare-ups) of novae and supernovae stars

A detailed mathematical treatment is in Refs 1 & 2 and a brief résumé of papers in Appendix p D1107
 Refs: 1) L.I. Sedov, DoklAkadN 111, No. 4 (1956) & 6thSympCombstn, 639-41 (1956) (Pub)d 1957
 2) I.M. Yavorskaya, DoklAkadN 111, pp 783-86 (1956) (ATS Transln from Rus RJ-783) (AEC TR-2931)

Detonation, Memory Effect. See under Detonation, Heat Sensitization and Memory Effect

Detonation (and Explosion), Metal-Charge Interactions. See under Deformation and Break-Up of Solids by Detonation (and Explosion) and also in Dunkle's Syllabus (1957-1958), pp 323-25

Detonation (and Explosion), Metastable Velocity of. Cook (1958), p 51 calls the low velocity of expls like NG - metastable. See under Detonation (and Explosion), High-, Low- and Medium-Velocity of

Detonation (and Explosion), Meyer Flow in Nozzle Theory. See under Detonation (and Explosion), Nozzle Theory or Expanding Jet Theory of Jones and also in Cook (1958), p 124

Detonation (and Explosion), Microwave Technique for Studying Detonation Phenomena. See Refs 36 & 71 under Detonation (and Explosion), Experimental Procedures

Detonation (and Explosion), Mikhel'son Straight Line. Same as Rayleigh-Mikhel'son Line described under Detonation (and Explosion) of Gases (Eq 9 & Fig A)

Detonation (and Explosion), Mining Effects in. See under Blast Effects in Earth, described in Vol 2 of Encycl, p B182

Detonation, Model of von Neumann-Zel'dovich.

Following is a resumé of paper by Fickett (Ref 2): If a cylinder of explosive is suddenly heated or struck at one end, a detonation wave propagates down the length of the charge with approximately constant velocity. This phenomenon is often treated by the model of von Neumann-Zel'dovich. Transport properties are neglected, and the wave consists of a plane shock followed by a short reaction zone of constant length in which the explosive material is rapidly transformed into decomposition or detonation products. The material at the end of the reaction zone is in a state of chemical equilibrium and enters a time-dependent expansion wave extending to the rear boundary of the charge. This model with the aid of the so-called *Chapman-Jouguet (CJ) hypothesis* reduces the problem of calculating the state at the rear boundary of reaction zone [termed the *Chapman-Jouguet (CJ) plane*], to the solution of a set of algebraic equations, provided that the equation of state of the detonation products is known. The CJ state and the corresponding propagation velocity are unaffected by the details of the flow in the reaction zone ahead or in the expansion wave behind. This simple theory has inspired a number of efforts to calculate the detonation properties of both gaseous and

condensed explosives. These calculations have been fairly successful for gaseous explosives, where the equation of state is known, but less so for condensed explosives, where it is not known

The calculations for condensed explosives, many of which are based on semi-empirical equations of state, have been reviewed recently by Jacobs (Ref 1)

Refs: 1) S.J. Jacobs, *AmRocketSocJ* **30**, 151 (1960) 2) W. Fickett, *LosAlamosScientifLaboratory Report LA-2712*, Los Alamos, New Mexico (1962), 9-10

Detonation, Molecular Theory of. Based on the Kihara & Hikita Equation of State (See in Section 3, k₂), these authors developed a theory which explained the variation of detonation velocity with loading density which was found satisfactory for PETN, TNT & Tetryl (Refs 1 & 2)

Refs: 1) T. Kihara & T.H. Hikita, *JInd-ExplsSocJapan* **13**, 3-8 & 77-85 (1952) & *CA* **49**, 5841 (1955) 2) *Ibid*, 4thSympCombstn (1953), pp 458-64 & *CA* **49**, 6608 (1955)

DETONATION, MUNROE-NEUMANN EFFECT (OR SHAPED CHARGE EFFECT) AND LINED-CAVITY EFFECT IN.

(Called also **Munroe Effect, Neumann Effect, Cavity Effect, Coned Charge Effect, Direction of Detonation Effect and Hollow Charge Effect**) (*Charge creuse ou Explosion à effet dirigé*, in Fr; *Hohlladung oder Hohlkörperprinzip*, in Ger; *Carica cava*, in Ital; *Carga hueca*, in Span; *Riktad Sprängverkan*, in Swed; and *Kumuliativnyi - ili Broneproghigayushchii Zariad; Napravlennyi Vzryv*, in Rus)

Munroe-Neumann effect is the property of explosive charges detonated in contact with objects of steel, concrete etc, to produce much deeper holes in the objects when the charge contains a cavity than when the explosive is solid. According to Birkhoff et al, (Ref 28) this property of explosives has been known for at least 150 years, the earliest reference to it being in 1792. Some application of the principle was made in the mining industry, but no one understood why hollow charges were more effective than solid ones

Foerster (Ref 1), as early as 1883, in describing charges prepared from compressed guncotton, pointed out the importance of using hollowed cartridges

In 1888, the American, Professor C.E. Munroe (Ref 1a), while working at the Naval Torpedo Station at Newport, RI, observed that if a block of cast high explosive with letters indented on the surface was placed with the letter-side against a metal plate and exploded, the letters would be reproduced indented on the metal plate. This phenomenon was explained by the fact that two or more explosive waves will resolve into a resultant wave which is of much greater force than any of the original waves. It might also be said that the explosive effect is concentrated in one direction, and for this reason a better penetration into the target is obtained

In the preparation of shaped charges, a cavity in the form of a carefully-shaped truncated cone is formed in the contact face of the bursting charge. The other end of the charge is also specially designed, so that the high explosive (HE) will be detonated in such a way that there will be a maximum resolution of the explosive waves produced into a powerful penetrating force, acting along the axis of the cone. The concentrated explosive effect produced by efficient design is such that only a relatively small amount of HE is required to penetrate several inches of steel or several feet of concrete

Munroe's discovery remained for many years without practical application, and was nearly forgotten. In 1910-1911, E. Neumann (Refs 1, 2 & 3), probably without being cognizant of Munroe's work, rediscovered the same effect and even claimed it as his own invention. It was patented in Germany (1910) and in England (1911) by Westfälisch Anhaltische Sprengstoff AG (Refs 2, 3 & 4), but no practical application was made immediately for military purposes. The idea, however, was utilized in the preparation of caps, as for example in the German "Sprengkapsel von Schulze", described in 1921 by Bomborn (Ref 8). Other German caps made use of the Munroe-Neumann effect,

as for instance, those described by Lupus (Ref 9). The possibility of the application of Munroe's idea to military explosives was described in Russia by Sukharevskii in 1925 (Refs 10 & 11). Lodati, in 1932 (Ref 12) investigated shaped TNT charges in Italy. Stettbacher in 1935 (Ref 13) proposed applying the idea to military ammunition, especially in mines. The Germans were apparently the first to use hollow-shaped ammunition, when they introduced it during the Spanish Civil War of 1936 (Ref 26, p 55)

After the Spanish War, other countries began to work on the idea of applying the Munroe effect to military use, but very little was published on the subject during that period (See Ref 17)

It seems that before the outbreak of hostilities in 1939, the Germans had developed the so-called "Magnetisch-anlehbenden Tankminen" (magnetic-adhering tank mines). These mines were hand-placed on a tank and, being provided with time fuses, they exploded after the men placing them had retired to a safe distance. Another development by the Germans was the "Panzerfaust". This was a shaped-charged projectile, stabilized in flight by tail fins. It was launched from a steel pipe, employing the recoilless mortar principle. As at least two men were required to handle the "Panzerfaust" (See Ref 52, p Ger 126), the weapon was not as convenient as the American "Bazooka" (See Ref 60a, p B26-L) which required only one man and could be fired in a manner similar to an ordinary rifle. Germans also used during WWII shells, bombs, grenades, and rockets with shaped charges. They are described, together with drawings in Refs 31a & 52

The Russians also used during WWII several types of shells with shaped charges. See Figs shown on p Rus 15 of Ref 43

The Japanese also developed a shaped charge (Lunge mine), which was fastened to the end of a long wooden pole. A soldier was supposed to charge out from ambush and jam the mine against the side of a tank. They also used some shaped-charge shells (Ref 31b)

During WWII the British developed the "Piat Bomb" and the "Bee-hive" (Ref 30, p 4)

Many other weapons utilizing hollow charges were designed and used in WWII, such as HE and AP (armor-piercing) shells, demolition charges, land and sea mines, torpedoes, etc. These weapons played a very important part in WWII. For example, in Ref 22, pp 11-16, are described various Amer demolition charges employed during WWII. They are now probably obsolete

After the termination of hostilities in 1945, a large quantity of military shaped charges was available to commerce at a fraction of the original cost, and some of them were tried by the mining industry. It was soon evident that, in certain cases, there is an advantage in using shaped charges. In other cases, however, the penetrating effect of the shaped charge did not give as good breakage as a charge that had a shattering effect. The main use of these charges seems to be in secondary blasting of boulders, for which "mudcapping" or "boreholing" was the usual practice

A series of articles (Refs 23, 24 & 27) describe the application of shaped charges in various branches of commercial blasting, such as mining, tunneling, oil well blasting, etc

In August and September of 1947, L.S. Byers, an explosive engineer of long experience, demonstrated at the Logan quarry of the Granite Rock Co of Watsonville, California, a very effective method for the reduction of boulders to crusher size (Ref 30). The method consisted in placing a specially designed, packaged shaped charge upon an extremely hard and tough boulder and exploding the charge without mudcapping or artificial covering of any kind. The boulders, estimated at from 1½ to 20 tons, were reported to have been broken to 100% crusher size by using about 1 lb of explosive per 2 tons of rock. There was a noticeable absence of flying pieces, and the breakage was left lying within a comparatively small area of the original position of the boulder

It appears that shaped charges might find considerable use in commercial blasting operations

According to Lawrence (Ref 27), the following types of cavities have been used in industrial shaped charges: conical, hemispherical, V-shaped and cylindrical

Although the phenomenon of hollow charges has been known for over 150 years, the enormous increase in penetrating power that can be produced by lining the explosive cavity with thin metal was discovered only sometime before WWII, although the Germans might have developed lined cavity charges as early as WWI (Ref 55, p 227)

Accdg to Cook (Ref 55, p 226) it is quite likely that the advantage of using lined cavity charges was recognized in Amer mining industry much earlier than 1936, the year in which Dr R.W. Wood is attributed by Eichelberger (Ref 41a) the discovery of the lined-cavity effect

Accdg to J. Mytryshyn, Picatinny Arsenal Operations Division, who presented the section on shaped charges in Dunkle's Syllabus (Ref 51, p 330), credit for the lined shaped charge should go to Dr R.W. Wood of Johns Hopkins, who first discovered that a metal liner in a cavity of an explosive charge gave high-velocity fragments and/or jets of metal. Henry Mohaupt and Major Delalande introduced steel-lined conical-cavity charges to the US Ordnance Department in 1940. Mohaupt also designed the 75- and 105-mm HEAT howitzer shell, the original shaped charge rifle grenade M9, and a machine gun grenade which later became the "bazooka". Mohaupt deserves credit for the US Army having shaped-charge ammunition as early as 1942. It has been suggested that the lined shaped charge effect be termed the **Mohaupt Effect**, and indeed we have come a long way from the original Munroe effect or simply cavity charge

In a similar historical description given by Cook, it is stated that Mohaupt was a "Swiss inventor who, in exploiting his patent, participated in early developments of the lined-cavity effect in America in the early part of WWII"

Cook also stated (pp 227-28) that fundamental and development studies of lined-cavity effect were begun in 1941 at Eastern Laboratory of DuPont Co and later parallel fundamental studies, as well as the design of weapons, were undertaken by Eastern Laboratory and Division 8, NDRC (National Defense Research Committee) Bruceton, Pa, under sponsorship of OSRD (Office of Scientific Research and Development), with Dr G.B. Kistiakowsky as chief scientist. About the same time E.M. Pugh organized a group at CIT (Carnegie Institute of Technology), Pittsburgh, Pa, to study the mechanism of penetration of jets from lined-cavity charges and means of protection against such jets

Following a meeting at Dumbarton Oaks, Washington, DC in March 1953, where the need for a more direct method of observing liner collapse and jet formation became apparent, scientists at BRL (Ballistics Research Laboratory) Aberdeen, Maryland, carried out monumental flash X-ray studies of cone collapse, jet formation, and target penetration. G. Birkhoff, upon observing some of the early radiographs obtd at BRL, made a brilliant suggestion that the cone-collapse process should be understood on the basis of hydrodynamics of fluid flow, and quickly formulated the framework of theory which he described in paper entitled "Explosives with Lined Cavities", listed here as Ref 28

Simultaneously with the work carried out in US, a group of scientists was engaged in similar studies in Great Britain with comparable results and success. Indeed, the currently accepted theory of liner collapse and jet formation was worked out there independently from Americans by G.I. Taylor from radiographs obtd by T.L. Tuck, even before those obtd at BRL

Following WWII, important contributions to the cavity effect were made in addition to the work at CIT and BRL, which continued the flash radiographic studies among other important investigations, by the following laboratories: NOL (Naval Ordnance

Laboratory), White Oak, Silver Spring, Maryland; NOTS (Naval Ordnance Test Station), China Lake, California; PA (Picatinny Arsenal), Dover, New Jersey; and SRI (Stanford Research Institute), Stanford, California

German research on shaped charges was briefly described in Ref 27a & 29. Studies were made of the detonation with hemispherical, ellipsoidal, and conical liners and a theory was developed which appeared to give a plausible explanation of the optimum shapes of liners. It was discovered during these studies, that high-speed rotation decreased very markedly the cavity effect, and that consequently, spin-stabilized projectiles were ill-adapted to cavity charges. Towards the end of 1943, the spreading of the jet, due to rotation, was confirmed photographically by the Kerr-cell camera

Studies were also made in Germany to find the best expl filler for cavity-charge projectiles and the maximum combination of explosives in composite fillers. For example, it was found, that 60/40-Cyclotol gave optimum performance when used as a filler and that aluminized explosives were of no advantage. Steel, sintered iron, copper, aluminum and zinc liners were studied but, although copper was found to be the best, they had to use zinc because copper was very scarce. The effect of tapering the liner with respect to thickness, the effects of varying the cone and the effect of varying the *standoff distance* (distance between the base of the liner and plate against which the projectile is fired) were also studied. The jet velocity, diameter, pressure, impulse, kinetic energy and the luminosity were studied as functions of the liner thickness and as functions of other parameters. A partially successful attempt was made to explain the observed results. It was calcd that detonation pressures were of the order of 200000 atmospheres, and jet velocities of the order of 25000 ft/sec (7620 m/sec)

The progress of detonation was studied by photographing hollow-charge projectiles, which had been cross-sectioned parallel to their longitudinal axis. It was found that, by an appropriate shape of the cavity and with an appropriate liner, the effective "standoff" could be greatly increased. For example, a 7 kg shaped charge could seriously damage an aircraft at a distance of 150 meters

Investigation conducted in Russia (Ref 26) showed that the effectiveness of metal-lined cavities can be as much as 4 times greater than those unlined. Moreover, jets from metal-lined shaped charges maintained a considerable penetrating power for some distance from the charge

Briefly, in the lined cavity method, a thin (ca 0.025 in) metallic liner, usually of steel or copper, is fitted snugly inside the cavity of the shaped charge. Such liners may be drawn, spun, stamped or cast. Roughly, the linings presently used in the US may be divided into "hollow-conical" - intended for penetration, and "wedge-shaped" - intended for cutting. The former produces a round jet of small diameter and the latter a thin, flat, knife-edge-like jet. As used, a shaped charge consists of the essential parts shown in Fig 1. If no cone liner is employed, such a charge has essentially the same effect as a lined charge placed in direct contact (without "standoff") with the steel target. In such a case, the action of the unlined charge is ascribed to not only incident and reflected shock waves, but also to a third particular type of shock wave formed as a result of collision of shock waves coming from the conical wall of the cavity. The action of such a charge, then, is that of a mass of dense gas moving with great velocity. On the other hand, the focused disruptive action of a lined charge in contact with a steel target is due to the jet formed by the solid, collapsed liner. If detonation of unlined and lined charges takes place with the charge at an appropriate distance from the target, the unlined charge is less effective, while the effectiveness of the lined charge is increased.

Under such conditions the effect of cavity in the unlined charge merges into the general blast effect of the charge (Ref 66, pp 5-29 & 5-30)

Cook (Ref 55, p 227) and Andreev & Belyaev (Ref 58, p 482) showed figs comparing flat end effect of a charge (a), versus Munroe-Neumann effect or unlined cavity effect (b), versus lined cavity effect (c) (See Fig 2, copied from Ref 58). In the experiment conducted in Russia, the bottle-shaped charge of Pentolite (1), 41.5 mm in diameter and weighing 150 g was placed as indicated in Fig, against the steel block (3), 82.5 mm in diam and 178 mm high, and then initiated from the top. The lining (4) of (c) was of steel 0.6 mm thick. Indentations (craters) (2) in (a) and (b) were nearly of the same diam as of the charge, but the depth of crater (2) in (b) was about 4 times greater than that of (a). The diameter of crater in (c) was smaller than in (a) and in (b) but its depth was 4 times greater than that of (b) and 16 times greater than that of (a). The form of crater in (c) was conical in its lower part, and terminating to a needle point

The basic principle of the lined cavity phenomenon is as follows, as revealed by high-speed radiographs and described by Birkhoff et al (Ref 28): Ignition of the fuse fires the priming charge, which causes the detonation of the booster followed by that of the HE charge. When the detonating wave reaches the apex of the thin-walled metallic cone, it suddenly produces very high pressures on the outside of the cone, causing its walls to collapse. These pressures on the outside cause the walls of the cone to move inward at high velocities. The moving metal retains a conical shape, with the apex moving forward along the axis. Behind the moving apex there is a section of thoroughly collapsed cone which contains only metal from the outer part of the cone. The inner part of the cone forms a *jet* which is squeezed out from the inner apex of the lining and travels at high speed along the axis, forward. In

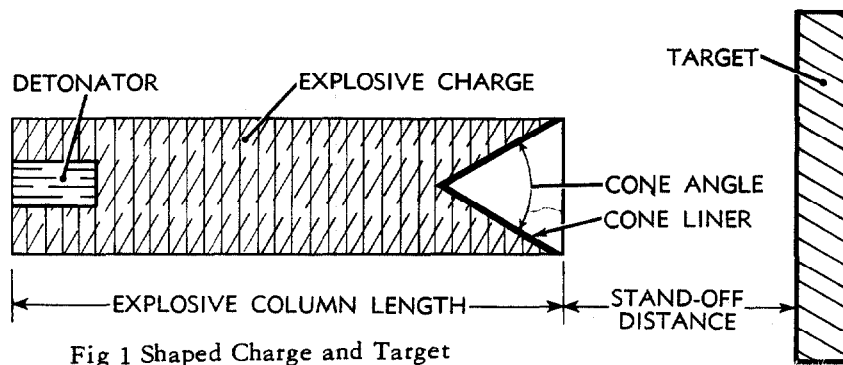

Fig 1 Shaped Charge and Target

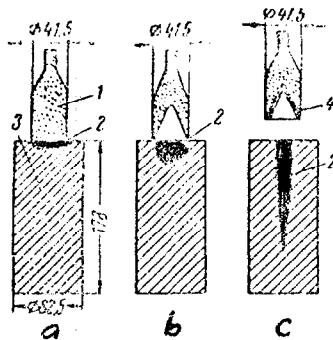

Fig 2 Comparison of Action of Charges

other words, the metal of the cone lining divides into two parts: the metal from the outer part of the cone forms into a *slug* that travels at comparatively low speed (500 to 1000 m/sec), while the inner part forms into a jet that travels forward along the axis at very high speeds (2000 to 10000 m/sec, about 6000 to 30000 ft/sec). (According to Ref 26, p 54, the velocities have reached 15000 m/sec). These velocities are about ten times as great as the muzzle velocity of ordinary rifle bullets, which are 600 to 900 m/sec - about 2000-3000 ft/sec. It is the jet and not the slug, as previously thought, that is responsible for all of the penetrating effect, because the high-speed jet pushes aside the target material (steel, concrete, etc) by pressing against it with extremely high pressures (0.3 million atmospheres). (According to Ref 26, p 54, these pressures are of the order of 100000 kg/cm^2)

It can thus be understood why the damage produced by lined cavities is much greater than that produced by unlined cavities. (According to Ref 26, p 58, the effect is increased about 4 times)

In Fig 9.16 of Ref 58, p 483, reproduced here as Fig 3, are shown various stages of detonation process in lined-cavity charge. Here the detonation wave spreads from left (a) to right (b) and its pressure causes the lining (1) to move towards the center where it is beginning to collapse. At this time a small *jet* (3) (*struya*, in Rus) emerges from the base of the cone while collapse continues and a *slug* (2) (*pest* or *sterzhen'* in Rus) starts to form. In the next stage (c), the cone is completely collapsed and the jet begins to elongate. Then in stage (d), the slug remains practically unchanged, while the jet becomes considerably elongated

Finally, the stage is reached (which is not shown in Fig, but described in Ref 66,

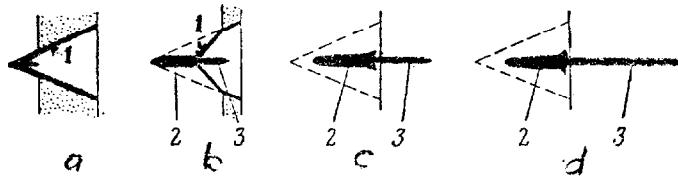

Fig 3 Various Stages of Detonation Process
in Lined-Cavity Charge

pp 5-30 to 5-32), in which the jet breaks up into small particles followed by the slug or the major portion of the completely collapsed cone

Birkhoff et al (Ref 28) gave a fairly complete mathematical theory of cavity-effect phenomenon together with experimental data that aided the formulation and testing of the theory. They based the theory upon the classical thermodynamics of perfect fluids. It is applicable because the strength of metals used for linings can be neglected at the high pressures encountered

Briefly, their calculations showed that:

- 1) Velocity of the jet increases with the decrease of the cone angle, but it can never exceed twice the detonation velocity
- 2) The diameter of the hole produced in the target is considerably greater than that of the jet. It is closely related to the energy delivered by the jet per unit depth of penetration. The hole diameters are smaller in hard materials than in soft ones, since more work is required to open the hole in harder materials. On the other hand, with most charges, the rate and depth of penetration into targets are nearly independent of the strength of the target material. This may be explained by the fact that, due to the high velocities of shaped charge jets, the pressures produced at the point of impact are far above the yield point of most materials. This means that penetration thru an armor-steel plate may be the same as thru an ordinary soft iron plate

- 3) Roughly, the depth of penetration by a given charge is inversely proportional to the square root of the density of the target

- 4) The average penetration into a given target at first increases and then decreases as the distance (*stand-off*) between the charge and the target is increased. For instance, in shooting with a charge containing 115 g of Pentolite with maximum diameter of 1-5/8 in. and a steel liner 0.025 in thick, the penetration into mild steel is 3-1/2 in at stand-off 0 in; 4-3/4 in at stand-off 1 in; 5-1/2 in at stand-offs between 2 and 3-1/2 in and then dropping to 5 in at 5 in stand-off; to 4 in at 7 in; and to 3 in at 11 in

- 5) As regards the material of the lining, it seems that steel and copper linings give the best results and aluminum liners the poorest

Lawrence (Ref 27) gave some values on penetrative effects of shaped charges consisting of 0.5 lb of Blasting Gelatin, 2 in diameter, provided with spun liners and primed with booster caps (See Table pD450) When using a 2 lb Blasting Gelatin shaped charge, 4 in diameter and about 6 in high, with the cavity lined with copper or steel, the stand-off distance was usually between 2 and 8 inches

- 6) According to tests conducted in Russia (Ref 26), 76 to 122 mm shells with shaped charges penetrated an armor approximately equal to the caliber of the gun, while ammunition of "close action", such as hand grenades, antitank projectiles etc, could

penetrate thicknesses equal to $1\frac{1}{2}$ to 2 calibers. As to the form of cavity, the best results were obtained with either semicircular or conical with rounded apex. The standoff for the first form could be much greater than for the second

According to Lawrence (Ref 27), when shaped charges with metal liners were pointed vertically upward, spectacular luminous jets, extending to a height of 60 feet were produced, while the jets from unlined cavities appeared to be almost completely diffused by the time they have traveled a relatively short distance

Some special forms of shaped charges are shown in Fig 4, reproduced from Ref 66, p 5-33 and the penetration of steel by a shaped charge is shown in Fig 5, reproduced from p 5-34 of Ref 66

The above description of Munroe-Neumann effect and of lined cavity effect must be considered as an introduction to the subject and some of the material may be obsolete. The description cannot be brought up-to-date because nearly all American and British military information of the last decade is classified

In conclusion we are including here a few words about "Defense Against Lined Shaped Charges", as given in Ref 51, p 342:

There are two types: passive and active. Armor is considered passive defense, but spiked armor of the type tried out not too successfully in both WWI & WWII may be considered as an active defense; this is because the spikes were supposed to attack the attacking round before it reached the main body of the armor. Particular details of proposed arrangements for both active and passive defenses are classified

Refs: 1) M. von Foerster, "Versuche mit Comprimierter Schiessbaumwolle" (Investigations with Guncotton), Mittler u Sohn, Berlin (1883) 1a) C.E. Munroe, Scribner's Mag 3, 563 (1888) and AmerJSci (Silliman) 36, Series 3, p 48 (1888) 2) Marshall 2

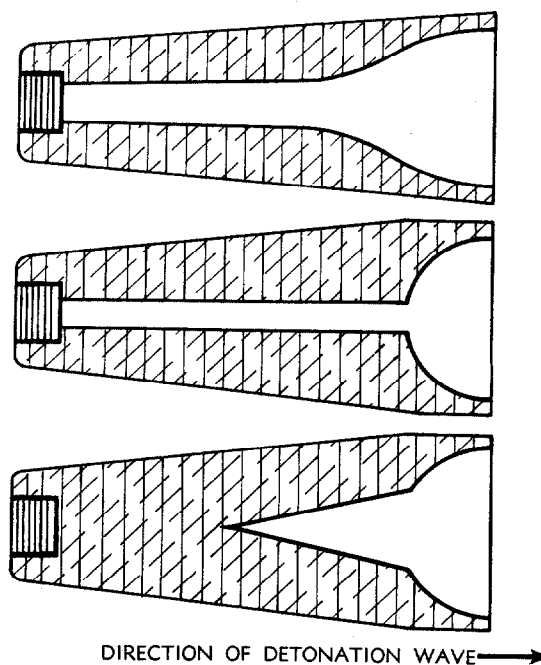

Fig 4 Special Forms of Shaped Charges

- (1917), 553 & 3 (1932), 169 3) E. Neumann, ZAngewChem 24, 2238 (1911) 4) Westfälisch-Anhaltische Sprengstoff AG, SS 6, 358 (1911) 5) E. Neumann, SS 9, 183 (1914) 6) A. Stettbacher, SS 10, 16 (1915) 7) A. Marshall, JSCI 39, p 35T (1920) 8) B. Bomborn, SS 16, 177 (1921) 8a) H. Kast, SS 19, 168 (1924) 9) M. Lupus, SS 20, 83 (1925) 10) M. Sukharevskii, Tekhnika i Snabgheniye Krasnoi Armii 170, 13 and 177, 13 (1925) 11) M. Sukharevskii, Voyna i Tekhnika 253, 18-24 (1926) 12) D. Lodati, GiornChimInd-Applicata 14, 130-32 (1932) 13) Stettbacher, (1933), 51-2 & 2 (1948), 133-35 14) W. Payman et al, PrRoySoc(London) 148A, 604-22 (1935) 15) A. Stettbacher, Nitrocellulose 6, 59-62 & 100-08 (1935) 16) R.W. Wood, PrRoySoc 157A, 249-61 (1936) 17) A. Stettbacher, Nitrocellulose 8, 58-62 & 79-85 (1937) 18) W. Payman & D.W. Woodhead, PrRoySoc 163A, 575-92 (1937) 18a) H. Muraour & J. Basset, CR 208, 809 (1939) 19) J. Basset & H.

Table

| Material | Liners | | Standoff (inches) | Perforation in steel (inches) | Diameter of hole (inches) |
|----------|-----------------------|------------------|----------------------|-------------------------------------|---------------------------------|
| | Thickness (inches) | Angle of cone | | | |
| Steel | 0.04 | 90° | 3.5 | 4 | 0.9 |
| Steel | 0.04 | 70 | 3 | 5.4 | 0.8 |
| Steel | 0.04 | 53 | 4 | 3.1 | 0.8 |
| Steel | 0.05 | 70 | 3.5 | 5.6 | 0.6 |
| Copper | 0.04 | 70 | 2.5 | 4.2 | 0.8 |
| Copper | 0.04 | 70 | 2.0 | 5.6 | 0.7 |
| Aluminum | Very poor results | | | | |

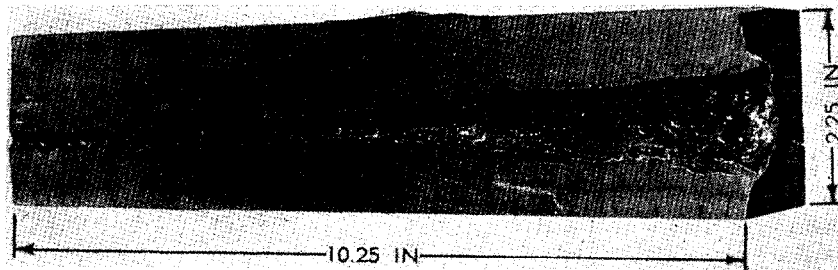

Fig 5 Penetration of Steel by Lined Shaped Charge

Muraour, Chim & Ind (Paris) No 3 bis, **45**, 218 (1941) 20) Davis (1943), 20 20a) G.I. Pokrovskii, "Boyevoye Primeneniye Napravlennago Vzryva" (Military Application of Directional Explosion), Voenizdat, Moscow (1944) 21) V. Torrey, Popular-SciMonthly **146**, 65 (1945) and Explosives-Engineer **23**, 160 (1945) 22) USWarDept-TechManual **FM 5-25** (1946), p 11 23) J.B. Huttel, Engineering and Mining **J No 5**, 58 (1946) 24) R.S. Lewis & G.B. Clark, BullUniv of Utah **No 5**, 37 (1946) 25) R.H. McLemore, Oil Weekly, July 8 (1946) 26) N.A. Shilling, "Vzryvchatyie Veshchestva i Snariazheniye Boyepripassov" (Explosives and Loading of Ammunition), Oborongiz, Moscow (1946) 26a) A.D. Blinov, "Kurs Artillerii" (Artillery Course), Voenizdat, Moscow, Vol 1 (1946), p 37 (All 12 volumes of this course are available at Library of Congress) 27) R.W. Lawrence, Explosives Engineer **25**, 171 (1947)

27a) L.E. Simon, "German Research in WWII", Wiley, NY (1947) 28) G. Birkhoff et al, JApplPhys **19**, 563-82 (1948) (Explosives with lined cavities) 28a) O. Nordzell, Teknik **1946**, No 12 (Sweden); French transl in MAF **22**, 247-56 (1948) (Explosions à Effet Dirigé) Charge creuse à coupelle métallique) 29) W.A. Noyes, Jr, "Science in WWII, Chemistry", Little, Brown & Co, Boston (1948), pp 72-4 30) L.S. Byers, Pit and Quarry, Nov **1949**, pp 1-7 31) L.S. Byers, "Multiple Jet Blasting Charge", USP 2513233 (1950) (It has been claimed that with lined-cavity charge of the form shown in Fig, a succession of jets appear to strike the object to

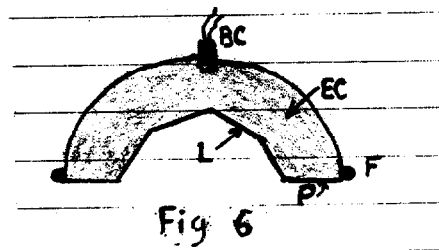

Fig 6

be blasted at spaced time intervals, and in any event a greatly augmented effect is produced. The effect is then, not only to penetrate deeper than with other shaped charges, but also to split and tear apart with greatly magnified results. Instead of scattering effect, which is common with expls, the effect is to break-up the rock, ore, etc. The meaning of BC in Fig is blasting cap, EC is explosive charge; F is flange; L is metallic liner and P is plate (metal, or plastic) serving as base

31a) W.M. Evans & A.R. Ubbelohde, *Research* **3**, 331-36(1950) (Formation of Munroe jets and their action on massive targets)

31b) *Ibid*, pp 376-78 (Some kinematic properties of Munroe jets)

32) J. et J. Basset, *CR* **231**, 1440-42(1950) (Influence of ambient pressure on the effects of hollow charges and the combustion of propellants)

32a) H. Muraour, *Chim & Ind (Paris)* **66**, No 5, p 658(1951) (On the diminution of brisance of hollow charges caused by rotation)

33) E.M. Pugh et al, *JApplPhys* **22**, 487-93(1951) (Application of Kerr-Cell to photographing of metal jets squirted from lined conical HE's charges)

34) D.C. Pack & W.M. Evans, *PrPhysSoc(London)* **64B**, 292-302 & 303-10(1951) (Penetration into a ductile target, such as lead, mild steel, etc)

35) Z. Fonberg, *JChemPhys* **19**, 383(1951) (Evidence of nuclear transmutation in the course of explosion of shaped charges with lined cavity); French transl in *MAF* **26**, 489-91(1952)

36) P. Tauzin, *MAF* **26**, 493-96(1952) ("Le phénomène Fonberg, est-il d'origine radio-active?")

37) E.M. Pugh et al, *JApplPhys* **23**, 532-37(1952) (Theory of jet formation by lined conical charges)

38) R.J. Eichelberger & E.M. Pugh, *Ibid*, 537-42(1952) (Experimental verification of the theory of jet formation by lined conical charges)

39) R.W. Lawrence, *USP* 2595960(1952); *CA* **46**, 7332(1952) (Highly efficient shaped-charge devices are prepd by pouring into thin-walled metallic containers of special shape a liquid mixture precooled to 0-5°C of a liquid nitric ester, such as NG together with 4-10% NC and not less than 1% antacid, such as chalk. The ensemble is warmed until gelatinization takes place and then cooled to RT. The resulting Blasting Gelatin can be initiated with a special No 8 electric blasting cap)

39a) Anon, "German Explosive Ordnance", **TM 9-1985-2** and **TM 9-1985-3**(1953)

39b) Anon, "Japanese Explosive Ordnance", **TM 9-1985-5**(1953)

40) Taylor(1952), 22-3 (Munroe effect, shaped charge, or coned charge effect)

41) R.I. Eichelberger, "Prediction of Shaped Charge Performance from the Release Wave Theory", 1st Quarterly Status Rept, "Fundamental Theory of Shaped Charges", CarnegieInst-Techn, Contract No **DA-36-061-ORD-394**, Jan 1954

41a) R.I. Eichelberger, "Re-examination of Theories of Jet Formation and Target Penetration by Lined Cavity Charges", Carnegie Institute of Technology, Dept of Physics, *CEL Rept No 1*, June, 1954 (See also Refs 46 & 47)

42) Anon, "Military Explosives", **TM 9-1910**(1955), 77-85 (Munroe effect)

43) *PATR* **2145**(1955), p Rus 15 (Russian shaped charge projectiles of WWII)

44) L.S. Holloway, "Flash Radiographs Showing the Collapse Process of Copper Shaped Charge Liners", *BRL Rept No 941*(1955)

45) A.M. Spencer, "The Determination of Reaction Rates of Nonideal Explosives from Shaped Charge Penetration Data", *Univ of Utah Inst for Study of Rate Processes, TechRept No XLVII*(1955) Contract N7-onr-45107

46) R.J. Eichelberger, *JApplPhys* **26**, 392-402(1955) (Re-examination of the unsteady theory of jet formation by lined cavity charges)

47) *Ibid*, **27**, 63-8(1956) (Experimental test of the theory of penetration by metallic jets)

48) T.C. Poulter & B.M. Caldwell, *Petroleum Transactions, AmInstMiningEngrs* **210**, 11-18(1957) (Development of shaped charges for oil well completion)

49) S. Singh, *JApplPhys* **28**, 1365-66(1957) (Possible explanation of "after-jet" by the detonation of shaped

- charges) 50) E.W. Brandt, "Projectile", USP 2787958(1957) (A method to overcome the effect of spin stabilization on shaped charge projectiles) 51) Dunkle's Syllabus (1957-1958), pp 329-42 (Shaped Charges, which contains: historical review, early theory, later modifications, release wave theory, explosive charge, spin and spin compensation, applications & effectiveness and defense against lined shaped charges); pp 343-54 (Pressure in liner and target, alternative cone collapse mechanism, liner properties, and jet density & velocity gradient) 52) PATR **2510**(1958), p Ger 46 (Faustpatrone - a hollow charge antitank rocket grenade fired from a tubular discharger); pp Ger 74 to Ger 79 (Description and drawings of German shells with hollow charges); p Ger 85 [Haft Hohlladung - an adhering (or sticking) hollow charge]; p Ger 86 (Hand grenades with hollow chges); p Ger 87 (Haftmine - adhering mine with hollow charbe); p Ger 91 (Hohlladung); pp Ger 91-2 (Hollow chge nose attachment for bombs); p Ger 92 (Drawing of various lined cavity charges); p Ger 92 (A drawing of a hollow demolition chge with 50/50 - RDX/TNT); p Ger 126 (Panzerfaust - a hollow chge antitank rocket grenade fired from a tubular discharger); p Ger 133 (Pistol grenade with hollow chge); p Ger 152 (Püppchen is a carriage-mounted 88 mm launcher for hollow charge rockets); p Ger 159 (Hollow chge rifle grenades); p Ger 162 (Hollow chge rockets); and p Ger 168 (Hollow chge rodded bomb) 53) Carnegie Institute of Technology, "Fundamentals of Shaped Charges, " 10thQuarterlyProgress-Rept, April 1958, Project 5B03-04-009. Project TB3-0134. Contract DA-36-061-ORD-513 54) A.B. Moore, USP 2831429 (1958) (Shaped charge for perforating oil well casing) 55) Cook (1958), Chapter 10, "Principles of Shaped Charges", which includes History (pp 226-28); Explosive factors in cavity effect (228-29); Application to mass loading in different geometries (229-35); Detonation pressure in nonideal explosives (235-44); Mechanism of linear collapse and jet formation (244-47); Metallographic examination of slugs (247-50); Velocity-mass properties of jets (250-52); Penetration of targets by lined cavity jets (252-55); Hole volumes in shaped-charge jet penetration (255-56); Hole volume in single-particle projectile impact (256-57); Kinetic energy of jet versus work of plastic deformation (257-58); Standoff in jet penetration (258); Commercial application of cavity effect (258-59); Ultra-high velocity and plastic velocity impact by single-particle projectiles (259-60); Theoretical threshold velocities V_c for impact explosion of massive target (260-61); Projectile impact explosions (261-62); Amount of target involved in impact explosions (262); Crater volumes in impact explosions versus high-explosive cratering (262-63); Plastic-deformation threshold velocity V_σ (263-64) 56) J.H. Church & G.J. Kessenich, USP 2839997 (1958) (Shaped charges) 57) Baum, Stanyukovich & Shekhter (1959). Chapter XII, entitled Komuliatsia (Accumulation), one of the Rus names for shaped charge effect (pp 459-554) 58) Andreev & Belyaev (1960), pp 481-89 (Komuliativnoye deystviye vzryva) (Effect of shaped charge explosion) 59) B.C. Taylor, "Effects of Boundary Rarefactions on Impulse Delivered by Explosive Charge", 3rdONRSymp-Deton (1960), p 267-84 (Calculation of velocity imparted to elemental areas of metal liners in contact with explosive charges of arbitrary shape by simplified theoretical description of the process) 60) R. Bauer, Ger P 1083734 (1960) & CA 55, 26448(1961) (Shaped charge mines with nonconducting lining) 60a) PATR **2700**, Vol 2(1962), p B26-L (Bazooka) 61) F.E. Allison & R. Vitali, "A Method of Computing Penetration Variables for Shaped-Charge Jets", BRL Rept **No 1184** (1963) 62) P.G. Sheth, IndianJTechn **3**(3), 100-02(1965) (Studies on the applicability of shaped charges in mining) 63) 4thONRSympDeton(1965) - No papers on this subject 64) C.E. Weinland & G.H. Lookhoff, "Warhead Digest", Propulsion Development Dept, NOTS (1965) (Conf) (It contains a list of titles of papers given at a classified 2nd International

Conference on Shaped Charges, Freiburg, Germany, Sept, 1961) (Quoted from Dunkle's private communication of Jan 1968) (Not used as a source of information) 65) PATR 2700, Vol 3 (1966), p D256 (Demolition devices using shaped charges)

66) Anon, "Military Explosives", TM 9-1300-214 & TO 11A-1-34 (1967), pp 5-29 to 5-35 (Munroe effect) 67) C.G. Dunkle; private communication; Jan 1968 68) 12th Symp-Combsta (1968) - No papers on this subject

List of Picatinny Arsenal Technical Reports on Shaped Charge

- a) A.B. Schilling, "Examination of Unfired 75 mm Hollow Charge HE Shell Complete Round of German Howitzer Ammunition", PATR 1454 (Nov 1954)
- b) A.B. Schilling, "Examination of Unfired AP Rifle Grenade, Japanese", PATR 1461 (Jan 1945)
- c) F.G. Haverlak, "Examination of Unfired 10.5 cm (105 mm) Hollow Charge HE Shell, Short Ogive, German", PATR 1481 (Jan 1945)
- d) G.M. Hopkins, "Evaluation of Explosives for Shaped Charges", PATR 1482 (Jan 1945)
- e) P.B. Tweed, "Loading Characteristics of 70/30 and 65/35 Cyclotol", PATR 1483 (Jan 1945)
- f) F.G. Haverlak, "Examination of 46 mm AP Rifle Grenades, German", PATR 1509 (March 1945)
- g) A.B. Schilling, "Examination of Japanese AP (Shaped Charge) Rifle Grenade with Special Fin Assembly", PATR 1511 (March 1945)
- h) A.B. Schilling, "Examination of 75 mm Hollow Charge HE Shell Complete Round for Japanese Type 41 Mountain Gun", PATR 1521 (April 1945)
- i) F.G. Haverlak, "Examination of 75 mm Hollow Charge HE Shell Complete Rounds for German Short Barrel Tank Gun, KWK 38", PATR 1540 (July 1945)
- j) S. Fleischnick, "Investigation of Factors Entering into Design of Shaped Charges (Loading and Testing of High Explosives in Shaped Charges)", PATR 1668 (Oct 1947)
- k) S. Fleischnick, "Investigation of Factors Entering into Design of Shaped Charges (Effects of Type of Booster, Charge Length, Confinement, and Type of Stand-off Support on Shaped Charge Performance)", PATR 1716 (April 1949)
- l) G.D. Clift & C.E. Jacobson, "Determination of the Effect of the Use of a Homogeneous Explosive and of Liners Made in Various Ways to Close Tolerances on the Performance of Experimental Shaped Charges", PATR 1975 (Oct 1953)
- m) C.E. Jacobson, "Design of an Improved Shaped Charge Liner for the 105 mm T43 HEAT Shell", PATR 2004 (March 1954)
- n) J.E. Andrews & G. Weingarten, "Light Emission Characteristics of Experimental Safe-Type Metal-Dust Photoflash Bombs (Shaped Bursters)", PATR 2047 (Aug 1954)
- o) G.D. Clift, "Effect of Removal of Air from Cast High Explosives on the Properties of These Explosives and the Performance of Small Experimental Shaped Charges", PATR 2147 (March 1955)
- p) C.E. Jacobson, "Segregation of Composition B in T108E45 90 mm HEAT Shell", PATR 2151 (March 1955)
- q) T. Fruchtman, "Development of 2.75-in HEAT Rocket Head, T2016E1 (M1)", PATR 2252 (December 1955)
- r) T. Fruchtman, "Development of T2917E1 2.75-in HEAT Rocket Head", PATR 2257 (December 1955)
- s) J. Spector & H. De Cicco, "Penetration Performance of a Series of T320E10 Arrow AP Projectiles", PATR 2278 (April 1966)
- t) G.D. Clift, "Performance of 57 mm Shell Containing Fluted Liners Coined by the Rubber-Covered-Punch Process", PATR 2293 (July 1956)
- u) G.D. Clift, "Performance of 57 mm HEAT Shell Containing Fluted Liners Coined by the Matched-Die Process", PATR 2300 (July 1956)
- v) G.D. Clift, "Centrifugal Casting of Explosive Charges for HEAT Shell", PATR 2381 (November 1956)

front and that the zone consists of nonreactive shock of pressure p_1 followed by a reaction zone in which the variables p , v , and ϵ change continuously to their final values p_2 , v_2 , $\epsilon=1$, along the Rayleigh-Mikhel'son line. Thus a detonation wave is composed of an initiating shock followed by a deflagration in which the pressure and density decrease from P_1, ρ_1 to P_2, ρ_2 . For detonating gases the pressure P_1 is about twice the C-J pressure (P_2)*

The shock part of the detonation wave is often called the *von Neumann spike* (Ref 9, pp 147-48)

Dunkle (Ref 7) stated that accdg to the NDZ theory the first part of the deton wave, sometimes called the von Neumann spike, is an almost ideal shock wave in which very little chem reaction takes place. While the pressure at the spike is ca twice the C-J pressure, the temperature is ca half the C-J temp. This initial pressure and temp rise occurs entirely within ca 10^{-5} cm thickness of the deton front. The 2nd phase of the deton wave is a gradual decrease in the pressure and an increase in the temp concurrent with the completion of the chem reactions. The length of the reaction zone can be detd experimentally from the minimum diam of a rod of explosive which propagates a steady-state detonation; also from the changes in the deton velocity when this rod is surrounded by an inert casing material of varying thickness; or from the decrease in the deton velocity when the deton wave is made to go around a bend of known radius of curvature

The spike represents the final pressure and density of a shock wave of sufficient strength to travel with the deton velocity. Nevertheless, accdg to Hirschfelder et al (Refs 4 & 5) the "representative point" moves up not along the *shock Hugoniot* (Fig 2), but along a curve representing equations of change which take into account the transport properties. Fig 3 shows T/T_0 as a function of ρ_0/ρ within a gas shocked from the initial condition $0(v_0, P_0)$ to the von Neumann spike N_1 and along the Rayleigh-Mikhel'son line from N to the C-J point

$C(v, P)$. It is seen that the temp of the spike N_1 is somewhat lower than half of the C-J temp. Since the temp is low, it is not expected that the chem reactions could occur to any appreciable extent in the short time required for the gas to pass thru the initial shock. Actually the temp at N_1 is so low that in many practical cases one would expect a time lag or a quenching zone before the reaction sets in. Hirschfelder inferred that accdg to NDZ theory some chem reaction can take place within the detonation front (in cases of unusually high reaction rates), and blunt the von Neumann spike, as can be seen in Fig 4 (Ref 7, pp 172-74)

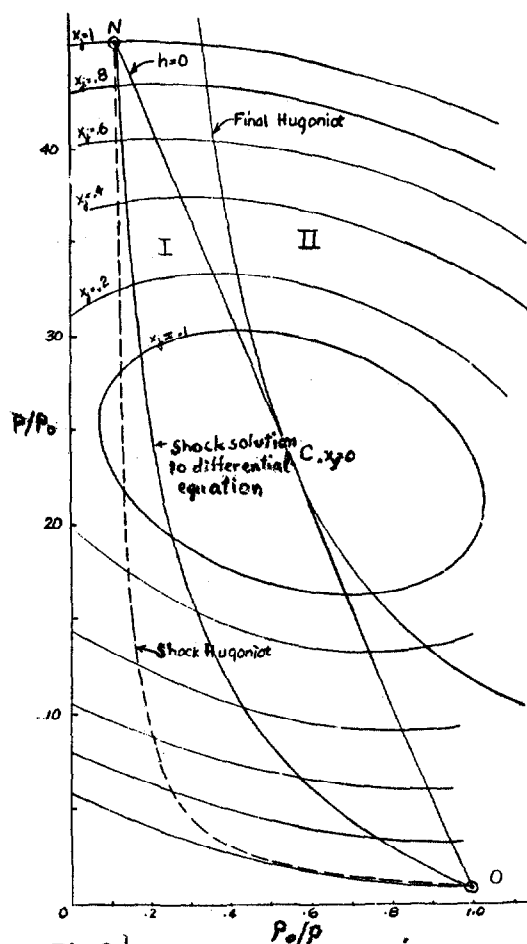

Fig 2. | A Rankine-Hugoniot diagram showing the shock solution of the differential equation, the initial and final Hugoniot curves of the line of $h = 0$ and the lines of $j = 0$

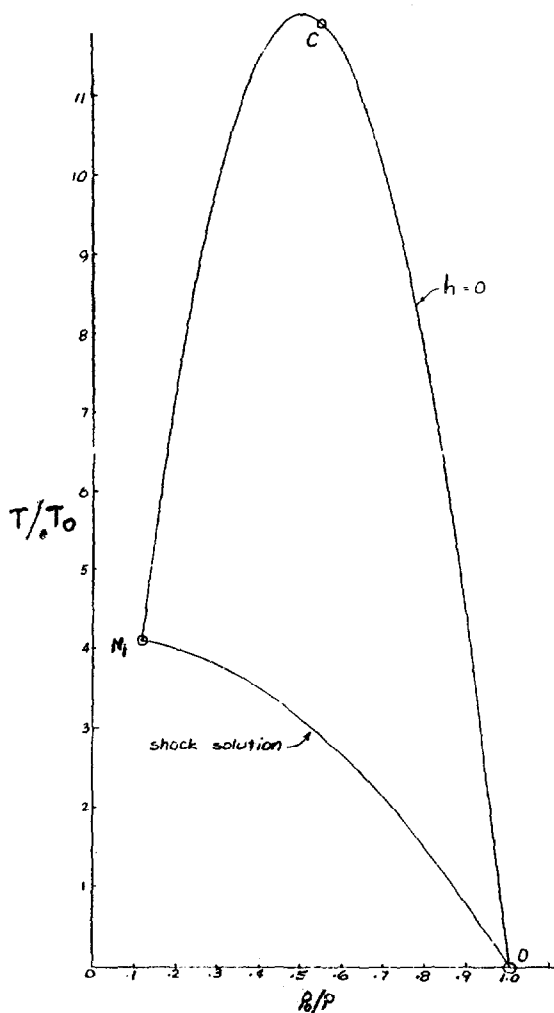

Fig 3. A cross plot of the Rankine-Hugoniot diagram (fig 11) showing the temperature along the shock solution and the $h = 0$ curve

Cook et al (Ref 6) considered that the jump condition of NDZ theory is not a satisfactory solution, but that pressure in the reaction zone is limited to values no greater than the pressure P at the C-J plane, except possibly for an extremely short distance of perhaps several mean free paths at the extreme front where thermal equilibrium may not exist (Ref 7, p 174)

Accdg to Dunkle (Ref 7, p 175), R.E. Duff & E.E. Houston of Los Alamos Laboratory estimated a spike pressure of 0.385 megabar, or ca 1.42 times the C-J pressure (0.272 megabar). These results were de-

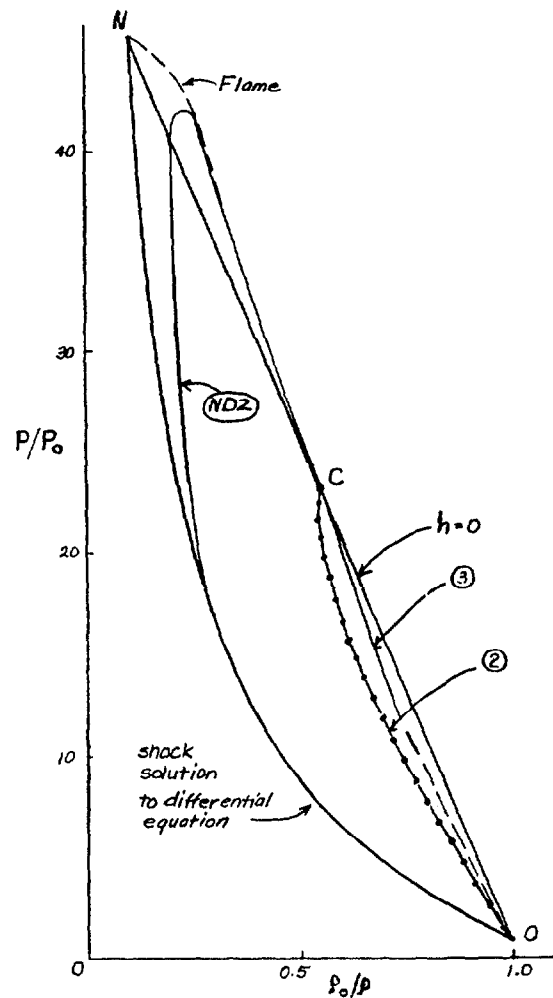

Fig 4. A schematic illustration of the three possible types of solutions of the detonation equations

rived from measurements of free surface velocities imparted to metal plates of various thicknesses by Comp B charges (contg 67% RDX) at density 1.67. A definite evidence of the spike in detonation of TNT was reported by W.E. Deal Jr of Los Alamos. H.D. Mallory & S.J. Jacobs of NOL concluded from similar experiments with cast TNT of density 1.58 that the pressure does not decrease immediately from the spike maximum but remains constant for ca 20% of the total duration of the detonation head, which means that the spike has a blunt head (Compare with our Fig 4). They found the pressure

of spike equal to 215 kbar, which is ca 1.21 times the C-J pressure (177 kbar)

Cook (Ref 8) calls this theory the *Zel'dovich-von Neumann-Doering theory* and states that it is frequently referred to as the *spike theory*. He further states that while the arguments of this theory are straightforward and convincing, they lack exptl proof and seem to be in conflict with some types of observations. It was shown in paper of Cook et al (Ref 6) that the ZND theory should be applied not with negligible heat conduction in the reaction zone, but with rather appreciable thermal conduction (Ref 8, pp 68-9). Fundamental mathematical considerations to justify the above statement are given in Ref 8, pp 69-75
Refs: 1) Ya.B. Zel'dovich, *ZhExspTeoret-Fiz* **10**, 542 (1940); Translated in *NACA TechMemorandum* **1261**(1950) 2) J. von Neumann OSRD Rept No **549**(1942) 3) W. Döring, *AnnPhysik* **43**, 421 (1943) 4) J.O. Hirschfelder, C.F. Curtiss & R.B. Bird, "Molecular Theory of Gases and Liquids", Wiley, NY (1953), 810, 811 & 814 5) J.O. Hirschfelder et al, "The Theory of Flames and Detonation", 4thSympCombustn (1953), pp 190-211 6) M.A. Cook et al, *TrFarad-Soc* **52**(3), 369-84 (1956) 7) Dunkle's Syllabus (1957-1958), 172-75 8) Cook (1958), pp 68-75 9) M.W. Evans & C.M. Ablow, *ChemRev* **61**, 147-48 (1961)

Detonation, Neumann's Pathological. Accdg to Evans & Ablow (Ref 2, p 148), it was pointed out by von Neumann (Ref 1) that for a family of Hugoniot curves having a form other than that shown in Fig 1 under "Detonation, NDZ Theory", the C-J hypothesis may be false and a weak detonation possible. If the reaction is not exothermic at all pressures and densities so that equation: $E^{(0)}(v,P) > E^{(\epsilon)}(v,P)$ (where $E^{(0)}$ is energy of reactant and $E^{(\epsilon)}$ energy of reaction zone, as shown in Fig 16, p 146 of Ref 2) does not represent the behavior of the material, then the Hugoniot curve can have an envelope as shown in Fig 19 of Ref 2, reproduced as Fig 5. In such a case it is possible for the state points to change discontinuity

from state 0 to state 1 with $\epsilon=0$ (points 1 & 2, respectively in the Fig) and then thru continuously changing values of ϵ from 0 to 1 at a lower intersection point on $H^{(1)}=J^{(1)}$ (point 4 in the Fig). This solution is known as *von Neumann pathological weak detonation*, since the reaction is completed at a lower intersection of the (R-M) Rayleigh-Mikhel'son line with $H^{(1)}=J^{(1)}$. In the Fig the point 1, which is lower intersection of R-M line with $H^{(0)}=0$ has Pressure P_0 and specific volume v_0 ; point 2 which is upper intersection of R-M line with $H^{(0)}=0$ has P_1, v_1 ; point 3 is R-M tangent to $H^{(\epsilon)}=J^{(\epsilon)}$ and to the envelope; and point 4 which is lower intersection of R-M line with $H^{(1)}=J^{(1)}$ has P_2, v_2 (Ref 2, pp 148-49)

No example of pathological detonation has been established (Ref 2, p 152)

Refs: 1) J. von Neumann, OSRD Rept No **549**(1942) 2) M.W. Evans & C.M. Ablow, *ChemRevs* **61**, 148-49 & 152

Detonation, Neumann Effect. See DETONATION, MUNROE-NEUMANN EFFECT

Detonation, Neumann(von)-Zel'dovich Model. See Detonation, Model of Von Neumann-Zel'dovich

Detonation, n-Fluid Theory. See under Detonation, n-Fluid Theory

Detonation of Nitromethane by Shock Interactions at Discontinuities was discussed by J.R. Travis at the 4thONRSympDeton (1965), pp 386-93

Detonation of Nitromethane-Tetranitromethane Mixtures: Low and High Velocity Waves! Title of the paper by A.B. Amster et al in 4thONRSympDeton (1965), 126-34

Detonation, Non-Chapman-Jouguet. In general, it is a *nonideal detonation* and it is described under "Detonation, Ideal and Nonideal

Detonation, Nonideal. See under Detonation, Ideal and Nonideal

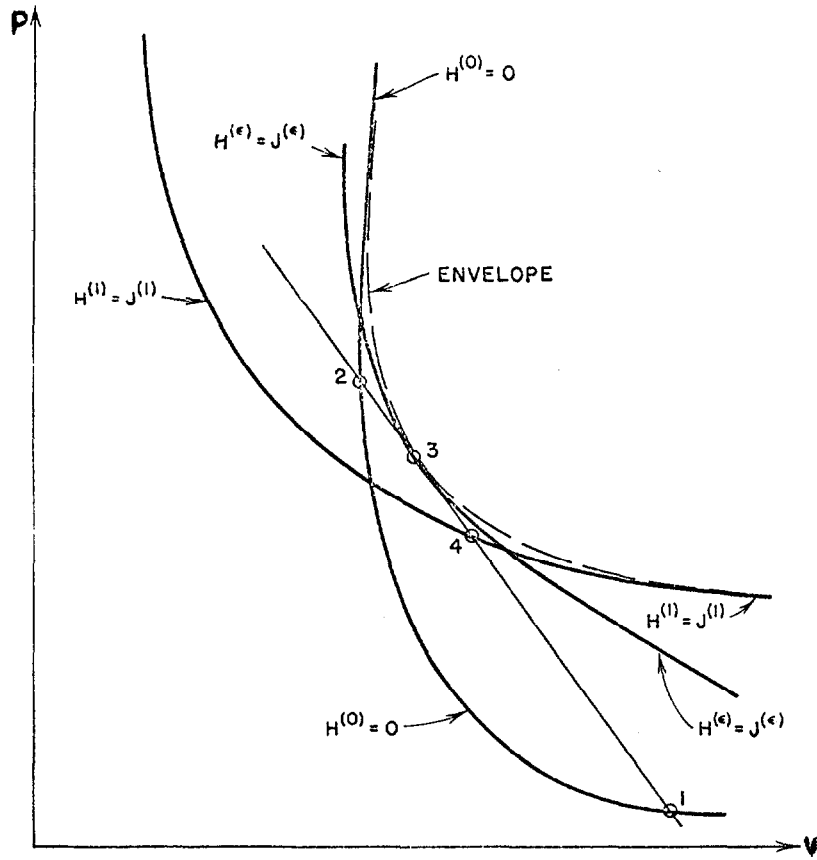

Fig 5. Von Neumann pathological weak detonation

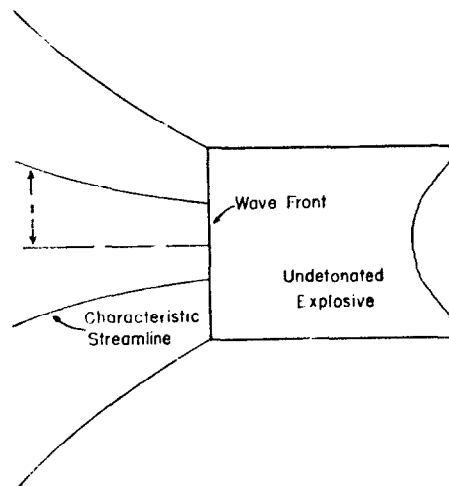

Fig 7. Jones nozzle in detonation

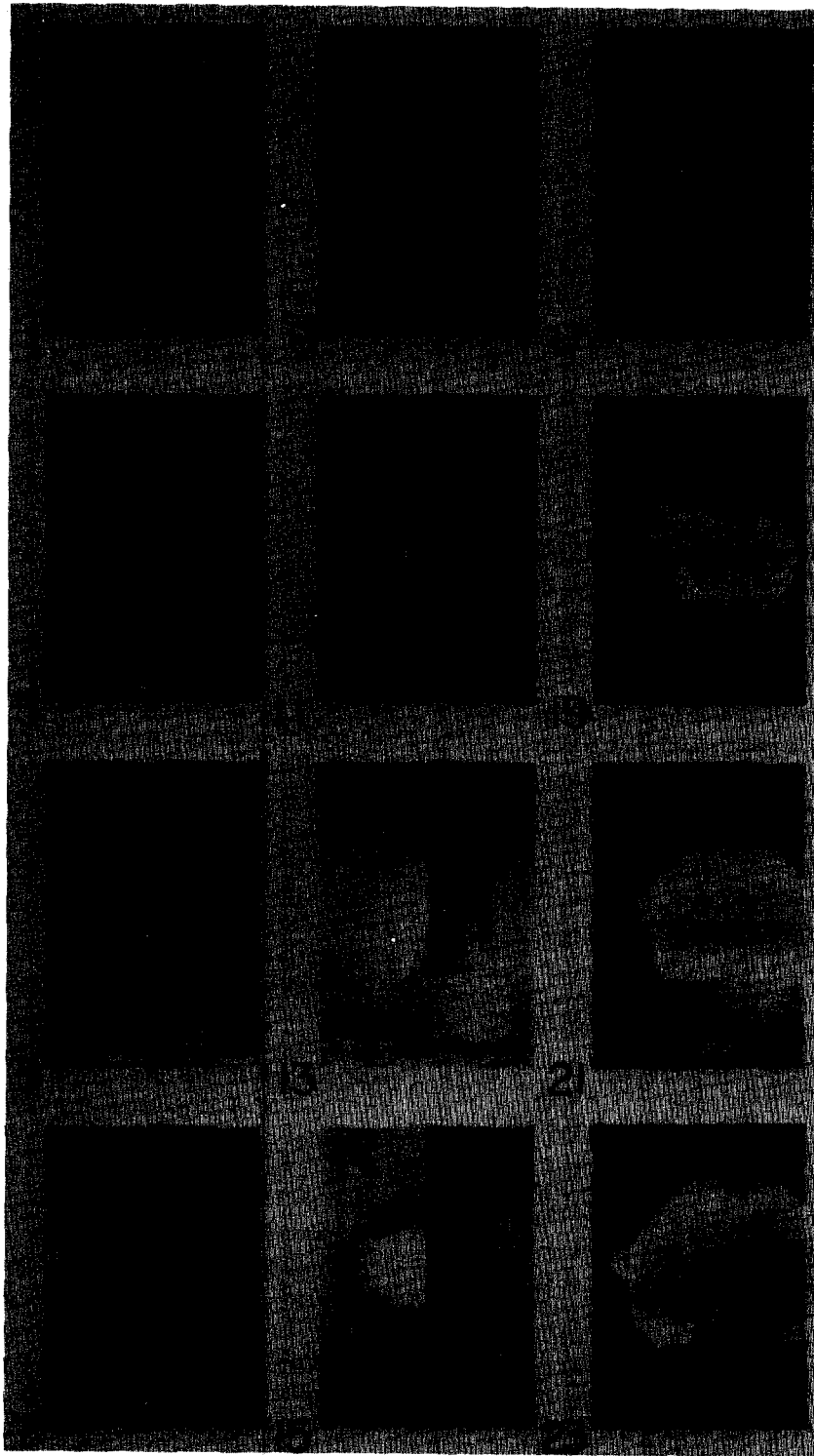

Figure 6. . Alternate frames of 23-frame sequence showing SPHF initiation of Composition B.

Detonation, Nonlinear Theory of Unstable One-Dimensional. J.J. Erpenbeck describes in *PhysFluids* 10(2), 274-89 (1969); CA 66, 8180-R (1967) a method for calcg the behavior of 1-dimensional detonations whose steady solns are hydrodynamically unstable. This method is based on a perturbation technique that treats the nonlinear terms in the hydrodynamic equations as perturbations to the linear equations of hydrodynamic-stability theory. Detailed calcns are presented for several ideal-gas unimol-reaction cases for which the predicted oscillations agree reasonably well with those obtd by numerical integration of the hydrodynamic equations, as reported by W. Fickett & W.W. Wood, *PhysFluids* 9(5), 903-16 (1966); CA 65, 82 (1966)

Detonation, Nonreactive Shock in. Cook (1958), pp 83-4 describes experiments of propagation of detonation thru glass or metal plates in SPHF (shock-pass-heat-filter) plates apparatus using Comp B charge as receptor. It has been understood that the plate transmits pure shock but filters out (or greatly retards) heat flow. Rapid camera photograph's alternate frames presented in Fig 4.12a, p 85 of Cook (our Fig 6 showed the progress of detonation thru filter (frames 1 to 5) and then thru the Comp B charge the progress of detonation thru filter (frames 1 to 5) and then thru the Comp B charge without causing its detonation (frames 7 to 15 incl). Since this part of the shock wave did not detonate the expl, it was called the *nonreactive shock*. The wave which followed (frames 17-23) did initiate the expl and may probably be called the *reactive shock*. Frames 17 & 19 showed that propagation proceeded in both directions. The wave moving in opposite direction is known as the *backward wave*. It was first observed in 1956 by L.N. Cosner & R.G.S. Sewell in studies at NOTS, China Lake, Calif

Cook also described on pp 138-40 the formation of nonreactive shock during investigation in SPHF apparatus the detonation of Dithenite 13 and Nitromethane

Detonation (and Explosion), Nozzle Theory or Expanding Jet Theory of Jones. This theory developed in GtBritain during WWII by Jones (Ref 1), is one of the approximate detonation theories. The other two being "Curved Front Theory of Eyring et al" and "Geometrical Model Theory of Cook et al". Jones theory considered the reaction front as a nozzle (Ref 2, p 101; Ref 4, p 2 & Ref 5, p 211) and studied the expansion to be expected in the flow at local sonic velocity thru such a nozzle. He also considered the front portion of the detonation wave as simply a shock wave traveling thru the unexploded material and the compression and temperature in the shock front initiating the reaction (Ref 6, p 123)

Accdg to Taylor (Ref 3, p 148), Jones assumed that all the energy is released during detonation and that chemical equilibrium is established in the reaction zone which he identified with the zone between the shock-front and the Chapman-Jouguet layer. This can hardly be exact if the confinement is imperfect, but for the expls to which Jones theory was meant to apply, this approximation was apparently justified

Nozzle theory was developed for bare cartridges, for cartridges confined in thin-walled tubes, and cartridges confined in thick-walled tubes (Ref 3, p 149). Accdg to Dunkle (Ref 5, p 211), the nozzle theory calculations for very heavily cased charges are complex and depend on angles of the streamlines assumed and on the directions of shock waves set up in the confining medium and in the detonation products

Cook (Ref 6) gave the following explanation of nozzle theory:

If it is imagined that the wave is traveling from left to right (Fig 7, pD458) thru the explosive and one transfers to a coordinate system moving with the shock front, the unexploded material would appear to be moving from right to left thru the shock front with velocity D . Then the products of detonation are issuing (accdg to Jones) from the reaction zone like material from a

nozzle with velocity $D - u = c$, where u is particle velocity and c is sound velocity. Jones also assumed that at points near the axis, shock front may be regarded as plane, and since the deton process is a steady one, the velocity of deton is entirely determined by the dynamic conditions within a small stream tube coaxial with the charge. He also considered that, to a good approximation, the hydrodynamic equations expressing conservation of momentum and energy thru the deton wave are unchanged by the effect of lateral expansion and that the equation of continuity (conservation of mass) may be written:

$$r^2(D - u)/v_2 = D/v_1$$

where r is the relative expansion of the central stream tube along the reaction zone; u = particle velocity; D = deton velocity; v_1 = specific volume of the original explosive and v_2 = sp vol at C-J plane. There were two steps in Jones determination of equations of his theory. He first solved the perturbed hydrodynamic equations for D , using a constant covolume equation of state. Then, using an expression for the ideal deton velocity D^* , he obt'd the equation:

$$(D^*/D)^2 = 1 + 2.25(r_1^4 - 1)$$

where r_1 = relative expansion of the central stream tube at the end of the reaction zone. To determine r_1 by hydrodynamic theory is difficult, but Jones obt'd an approximate solution in the following manner. He assumed that for unconfined charges the gases from the outer layers of the expl follow the flow lines given by Meyer's solution for flow around the corner, while gases from the inner part of the explosive expand at constant pressure in a cross section. In a brief discussion by Cook (Ref 6, p 124-L), it is stated that Jones, in considering a tube generated by rotation of the Meyer streamline about the axis, found the Meyer streamline which generated the tube of flow most nearly characteristic with the actual tube of flow. He found that the proper streamline began 46% of the distance from the surface of the charge toward the axis and then he was able to obtain an approxi-

mate value for r_1 as a function of reaction-zone length

Jones' final result of calculation is given by the equations:

$$(D^*/D)^2 = 1 + 9/4 \{ \phi^4(a_0/y) - 1 \}$$

$$\phi(a_0/y) = (37/20) \{ 1 - (a_0/y) \cot \theta \}$$

$$(a_0/y) = (34/37) \{ \sin \theta (1 + \cos \sqrt{2\theta}) \}$$

where a_0 = reaction-zone length; y = charge radius; ϕ = function in nozzle theory; and θ = angle in nozzle theory (Ref 6, pp 124 & 377-78)

Nozzle theory is also described in Russian (Ref 7) under the name "teoriya sopla"

Refs: 1) H. Jones, PrRoySoc **189A**, 415 (1947) 2) H. Eyring et al, ChemRevs **45**, p 101 (1949) 3) Taylor (1952), 148-50 4) B.J. Zwolinsky, "Some Thoughts and Speculations on Explosives", Stanford Research Institute Internal Report SRI **014-54** (1954) 5) Dunkle's Syllabus (1957-1958), 188 & 211-12 6) Cook (1958), 123-24 & 243 7) Baum, Stanyukovich & Shekhter (1959), 266 (Nozzle theory)

Detonation (and Explosion), Nuclear. A.

brief description is given in Vol 1 of Encycl, p A51-R under "Atomic Energy" and to this may be added the following:

Addnl Refs: A) Dunkle's Syllabus (1957-1958), 391-404 B) G.W. Atkinson et al, "Nomographs for Determining the Relationships Between Pressure, Range, Altitude, and Yield in the Shock Front Resulting from a Nuclear Detonation", NavWeps Rept **8295** (1965)

Detonation, Oblique Impact of a Layer of Explosive by a Metal Plate in.

David et al (Ref) conducted experiments on initiation of explosives by impacts upon them of metal plates. When the metal plate came in contact with the layer of explosive, not all at once but gradually, an oblique detonation wave was initiated. In experimental arrangement shown in Fig 1, a metal plate (such as of Cu), was bent thru an angle ϕ by means of a detonation wave of known velocity traveling thru a layer of explosive. When the plate was deflected, it hit at an

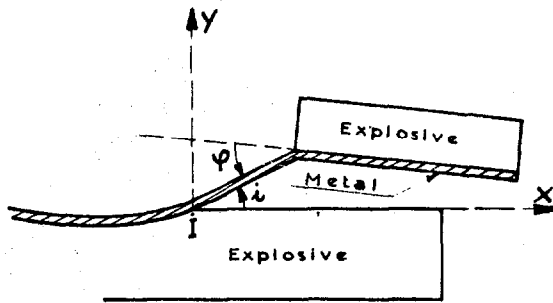

Fig 1 - Experimental arrangement

angle of incidence i , a block of explosive of density ρ_0 . The thicknesses were sufficiently small compared to the other quantities so that the flow could be considered as plane two-dimensional and stationary. The reference system had its origin at the point of impact I and was under uniform linear motion. Theoretical and experimental studies were carried out in the vicinity of the point of impact. All the waves originated in the vicinity of the point of impact so that they arrived into the explosive and its detonation products from above, and into metal plate from below. It was shown theoretically that in some cases compatibility at the interface can be achieved only by taking into account an *overdetonation wave* of given characteristics. Experiments pointed to the existence of such a wave. By tracing graphs its characteristics could be measured
 Ref: F. David et al, "Oblique Impact of a Layer of Explosive by a Metal Plate", 4thONRSympDeton (1965), p 381-85

Detonation, Overboosting in. Detonation can propagate at rates above normal and this is known as *hypervelocity* or *supervelocity*. This phenomenon is described under "Detonation, Supervelocity or Hypervelocity of". One of the actions which can drive the velocity to a higher rate than normal is "overboosting", which was investigated by Deffet et al (Ref 1). They

used two expl compns in 22mm-diameter columns, one normally detonating at 3250, the other at 1970 m/sec. When a 10-cm long column of the 1st expl was used to booster a 25-cm column of the 2nd expl, the velocity averaged 2234 m/sec at 5-15 cm of the 2nd column and 2160 m/sec at 10-20 cm, counting from the boundary between the two expls. The normal velocity of 1970 m/sec of the 2nd column was not reached even after 25 cm length. Persistence of higher than normal velocity over such a distance in this expl was attributed to its consisting of a non-gelatinous mixture of NG and Na bicarbonate (Refs 1 & 2)

Accdg to Dunkle (Ref 2, p 284), explosive No 2 used by Deffet belongs to Class 3 of W. Taylor, (powdered explosive compositions containing a liquid sensitizer such as NG) in which a multiplicity of reaction centers may have an accelerating effect. A similar accelerating effect was observed in expl mixts of NaCl and NG. Here mixts contg larger crystals of NaCl had higher velocities than those with small crystals. High vels for the largest salt granules indicate unimpeded progress of the detonation wave around them thru NG. As the granules decrease in size and grow in number they restrict the detonation and velocity falls; it soon rises again, either because of new reaction centers created by the trapping of NG films between impacting particles, or because of increase in the number of air pockets (Ref 2, p 274)
 Refs: 1) L. Deffet et al, pp 481-82 in the 4thSympCombstn (1953) 2) Dunkle's Syllabus (1957-1958), 274, 284 & 292

Detonation, Overcompressed Wave in. See under DETONATION (AND EXPLOSION) WAVES

Detonation, Overdetonation. See under Detonation, Supervelocity (or Hypervelocity) in

Detonation, Overdriven. See under Detonation, Supervelocity (or Hypervelocity) in

Detonation (and Explosion) Parameters and Characteristics.

A "parameter" is a quantity which may have various values each fixed within the limits of a stated case or discussion (Ref 4a). Detonation parameters are density, heat of detonation, pressure developed on deton, temperature developed on detonation, detonation velocity, energy, propagation velocity, brisance, impetus (power), specific impulse, etc. These values seem to be identical with those called "Caractéristiques des Explosifs et de Poudres" by French scientists. Some of them are listed in Vol 2 of this Encycl, p C149-L as "Characteristics of Explosives and Propellants". Some scientists list parameters as "properties"

Kistiakowsky listed in Table V, p 957 of Ref 1 values for parameters of detonation for TNT and Dunkle listed in Table XXIV, p 263 of Ref 3 the parameters for TNT, RDX, 77/23-Cyclotol and Composition B. Table A lists some of these parameters:

Table A

| Explosive | Detonation Parameters | | | |
|----------------|-----------------------|-----------|-----------------|------------|
| | ρ_o in g/cc | P in kbar | E_o in kcal/g | D in m/sec |
| TNT | 1.64 | 178 | 0.530 | 6951 |
| RDX | 1.76 | 325 | 1.083 | 8622 |
| 77/23-Cyclotol | 1.74 | 313 | 1.200 | 8252 |
| Comp B | 1.71 | 293 | 1.16 | 8022 |

where ρ_o = density of expl, P = pressure developed on deton, E_o = energy available to perform work if expansion could continue to zero density and zero temp (in °K) and D = deton velocity

Dewey (Ref 2) described determination of detonation parameters from photographic observations. Cowan & Fickett (Ref 4) determined the effects of the various Kistiakowsky-Wilson equation of state parameters on the calculated D- ρ_o curve for 65/35-RDX/TNT expl mixture. Baum, Stanyukovich & Shekhter (Ref 5) presented some parameters of shock waves. Stein

(Ref 7) conducted at PicArasn a quantitative study of parameters affecting bullet impact sensitivity of explosives. Dremine & Pokhil (Ref 6), Voskoboinikov & Apin (Ref 8), Zubarev & Telegin (Ref 11) and Dremine et al (Ref 12) conducted in Russia determination of parameters for condensed explosives. Their data as well as the data reported by Mader (Ref 9), Fickett (Ref 11), and others were used by Dunkle (Ref 17) in compilation of 7-page tables, entitled "Compilation of Published Chapman-Jouguet Parameters". These tables are given by us in abbreviated form under "Detonation, Chapman-Jouguet Parameters in"

Dremine et al (Ref 12) gives values for the following parameters of RDX & TNT: D = detonation velocity, U_1 = velocity of detonation products at the detonation-wave front, and P_1 = Chapman-Jouguet-plane pressure at various densities

Table B

| Substance | ρ_o g/cc | D | U_1 | $P_1 \cdot 10^{-8}$ bar |
|---------------|---------------|--------|-------|-------------------------|
| | | km/sec | | |
| RDX | 1.755 | 8.66 | 2.41 | 366 |
| RDX | 1.59 | 8.10 | 2.23 | 287 |
| RDX | 1.40 | 7.44 | 2.05 | 213 |
| TNT | 1.59 | 6.94 | 1.83 | 202 |
| TNT | 1.45 | 6.50 | 1.72 | 162 |
| TNT | 1.30 | 6.00 | 1.58 | 123 |
| NG | 1.60 | 7.65 | 2.06 | 253 |
| Nitromethane | 1.14 | 6.30 | 1.80 | 129 |
| 75/25-TNT/RDX | 1.65 | 7.31 | 1.96 | 236 |
| 50/50-TNT/RDX | 1.68 | 7.65 | 2.07 | 266 |
| 25/75-TNT/RDX | 1.71 | 8.12 | 2.23 | 310 |

Mader (Ref 13) detd several detonation parameters for numerous expls with the IBM-7030 STRETCH Computer using the Becker-Kistiakowsky-Wilson equation of state. These parameters are listed by us under "Detonation (and Explosion), Equations of State Used in". He also detd several Chapman-Jouguet parameters

Lutzky (Ref 14) determined detonation parameters for TNT using the Landau-Stanyukovich equation of state modified by

Zel'dovich & Kompaneets, with the aid of an IBM-7090 Computer. Hurwitz (Ref 15) detd detonation parameters for TNT, PETN & RDX with RUBY Code using the Kistiakowsky-Wilson equation of state modified by Cowan & Fickett and by Mader. Price & Hurwitz (Ref 16) detd deton parameters for some C-H-N-O expls with RUBY Code

Price (Ref 16), p 17, Table IV gives a comparison of computed detonation parameters for typical members of group 1 and group 2 explosives. Group 1 are granular pressed materials exhibiting more ideal behavior at lower porosities, while group 2 expls are more ideal at higher porosities. To the group 1 belong: PETN, RDX, TNT, while to group 2: HN (Hydrazine Nitrate), NGu (Nitroguanidine) and AP (Ammonium Perchlorate) (See Table C)

Note: Under "chemical energy" is understood the change in internal energy for reaction occurring at initial temperature and pressure (See also under "Detonation, Chapman-Jouguet Parameters in)

Refs: 1) G.B. Kistiakowsky, "Theory of Detonation of Explosives", pp 955-57 in Kirk & Othmer 5(1950) (Not found in the 2nd edition of Kirk & Othmer) 2) J. Dewey, BRL (Ballistics Research Laboratory) Report 828(1952), Aberdeen, Md 3) Dunkle's Syllabus (1957-1958), p 263, Table XXIV (Detonation parameters); 270-77 (Charge parameters) 4) R.D. Cowan & W. Fickett, JChemPhys 14, 934-35 (1956) 4a) Glossary of Ordn (1959), p 208-L (Definition of a parameter) 5) Baum, Stan-yukovich & Shekhter (1959), 318-62 6) A.N. Dremin & P.F. Pokhil, DoklAkadN

128, 979(1959) 7) S.D. Stein, PA FREL TR 2626(1959) 7a) A.N. Dremin et al, DoklAkadN 131, 1140-42(1960) (Effect of Al on detonation parameters of TNT) 8) I.M. Voskoboinikov & A.Ya. Apin, Dokl-AkadN 130, 804(1960) 8a) A.N. Dremin & G.A. Adadurov, IzvAkadNauk, OtdKhim-Nauk 1961, 157-58 & CA 57, 16953(1962) (Deton parameters for nonhomogeneous 68/32-TNT/RDX) 9) C.L. Mader, "Detonation Performance Calculations Using the Kistiakowsky-Wilson Equation of State", LosAlamosScientificLabRept LA-2613 (1961) 10) W. Fickett, "Detonation Properties of Condensed Explosives Calculated With an Equation of State Based on Inter-molecular Potentials", Ibid, LA-2712 (1962) 11) V.N. Zubarev & C.S. Telegin, Dokl-AkadN 147, 1122-25(1962) 12) A.N. Dremin et al, "Detonation Parameters", 8thSympCombstn (1962), pp 610-12 13) C.L. Mader, LosAlamosScientificLaboratoryRept LA-2900 (1963) 14) M. Lutzky, USNavalOrdnanceLaboratory, NOLTR 64-40 (1964) 14a) V.N. Zubarev & G.S. Telegin, DoklAkadN 158(2), 452-5(1964) & CA 61, 14456(1964) (Calculation of the composition of explosion products and the detonation parameters of condensed explosives TNT, RDX, PETN & PA) 15) H. Hurwitz, NOLTR 63-205(1965) 16) D. Price & H. Hurwitz, NOLTR 63-216(1965) 17) C.G. Dunkle, APL (Applied Physics Laboratory), The Johns Hopkins University, Silver Spring, Maryland, Report BBW/CGD/M13 (1965), Tables on pp 5 to 11, incl 18) Donna Price, "Contrasting Patterns in the Behavior of High Explosives", pp

Table C

| Explosive | PETN | RDX | TNT | HN | NGu | AP |
|-------------------------------|------|------|------|------|------|------|
| Crystal density g/cc | 1.78 | 1.80 | 1.65 | 1.68 | 1.78 | 1.95 |
| Velocity, D, mm/ μ sec | 8.34 | 8.57 | 7.29 | 8.46 | 8.38 | 6.43 |
| Pressure, P, kb | 324 | 341 | 222 | 290 | 298 | 187 |
| Temp, °K | 2812 | 2668 | 2736 | 1218 | 1385 | 780 |
| Chemical energy, cal/g | 1520 | 1486 | 1265 | 908 | 922 | 395 |

700-01 in 11th Symp Combustn (1967) (Detonation parameters for two groups of HE's)

Detonation, Particle Size Effect in.

The effects of particle size on detonation rate have been studied by observing the functioning of mixes of various granulations in pressed expl charges, and the influence of cryst size on the props of castings of formulations, such as of Comp B. Copp & Ubbelohde (Ref 1) reported such studies for Amatols, Eyring et al (Ref 4) for Ammonium Picrate, Tranter (Ref 3) and Davis et al (Ref 8) for TNT castings, Jones & Mitchell (Ref 2) for granular TNT & pressed Tetryl, Malin et al (Ref 9) for Comp B, and Cook (Ref 7) for some composite expls

In the case of Ammonium Picrate, addn of either a small percentage of coarse to fine material or *vice versa* lowered the detonation rate. Also under the conditions studied, a mixt of 70% coarse & 30% fine particles would not propagate detonation

Cybulski et al (Ref 5) found that castings of TNT made under conditions favoring small particle sizes had higher rates of deton and smaller critical diameters. While in general the explanations advanced have applied to chges of limited diam, the work of Malin et al (Ref 9) indicates that measurable particle-size effects persist to infinite diam. Tranter (Ref 3) reported similar studies on the effect of rate of cooling of cast TNT on deton rate. In both granular TNT & Tetryl of low density, the particle size distribution can determine whether the deton will proceed at high or low order

Davis et al (Ref 8) produced annular deton waves in cylindrical chges of TNT prepd by pouring the molten expl into metal molds at RT. These waves originated at the surface, spread inward as they progressed, and finally coalesced over the entire chge diam. It was found that the surface-chilled outer layer was finely crystalline. There was a progressive coarsening in size of crystals from the surface inward, and evidently the most sensitive regions were near

the surface. Charges prepd in heated molds had larger overall cryst size and less sensitivity. These results confirmed the observation of Tranter (Ref 3) that the deton rate in cast TNT under heavy confinement is highly dependent on the chge casing temp before filling and on the subsequent rate of cooling

Copp & Ubbelohde (Ref 1) consider that the Ammonium Nitrate crystals in Amatols react by an erosive burning which is slower than the decompn of the TNT matrix. This lengthens the reaction zone and thus alters the diam effect by increasing the time reqd for complete reaction

The Comp B mixt studied in detail by Malin et al (Ref 9) differed from the Amatols in that the grist component (RDX) had the higher reaction rate and, therefore, was the better expl. In Comp B the critical diam was considerably reduced, and the deton rates of small diam chges were higher when a finer RDX was used. Separate Comp B samples were prepd from each of two grist sizes of RDX. The first had a bimodal particle size distribution with maxima at 600 & at 50 microns; its Comp B had a $D=7975-58$ m/sec. The second sample of RDX had a single max at 150 microns, and about the same percentage of crystals less than 100μ as in the first sample; its Comp B had a $D=8009-76$ m/sec. The authors claim that the difference in D values for infinite radius is not an artifact, and offer an explanation based on the Kirkwood-Wood theory which applies the general rule that the boundary betwn two space-time regions in which the flow is nonsteady must be a characteristic of the system

See also Refs 4, 10 & 11 for more detailed information

Refs: 1) J.L. Copp & A.R. Ubbelohde, *TrFaradSoc* **44**, 646-48, 658-69 (1948)
 2) H. Jones & D. Mitchell, *Nature* **161**, 98 (1948) 3) T.C. Tranter, *Nature* **162**, 335 (1948); **172**, 81 (1954) 4) H. Eyring et al, "The Stability of Detonation", *Chem-Rev*s **45**, 69-178 (1949) 5) W.B. Cybulski et al, *PrRoySoc* **197A**, 51-72 (1949) 6)

Taylor (1952), pp 142-45 7) M.A. Cook, *JPhysChem* **58**, 1114 (1954) 8) D.J. Davis et al, *Nature* **179**, 910 (1956) 9) M.E. Malin et al, *JApplPhys* **28**, 63-69 (1957) 10) Dunkle's Syllabus (1957-58), pp 213-14 11) Cook (1958), pp 44-49, 102, 129-30 & 237-44 12) L.D. Sadwin et al, "Non-ideal Detonation of Ammonium Nitrate-Fuel Mixtures", 3rdONRSympDeton (1960), 309-25 13) Marjorie W. Evans et al, "Shock Initiation of Low-Density Pressings of Ammonium Perchlorate", 4thONRSymp-Deton (1965), 359-72

Detonation, Particle Size Effect on Velocity of.

Many US commercial expls are usually TNT mixed with a nitrate, or oxygen-balanced AN-fuel mixts, which are generally less sensitive than NG expls. Their constituents can remain in the form of separate granules or the TNT may coat the surfaces of the less reactive particles. Working with Amatols (AN/TNT 79/21) in which the nitrate grains were coated, Paterson(Ref 1) determined detonation velocities for different granulations of AN in a range of diameters so as to extrapolate to the "ideal" rate and eliminate the effect of diam. The ideal rate turned out to be 4500 m/sec with AN of +170 BSS mesh and 2200 m/sec with AN of -60 BSS mesh. A similar particle-size effect was found by Malin et al (Ref 4) to persist to infinite diam in chges of Comp B & RDX

Cook (Ref 2) reported that an inert additive, such as fine NaCl, in amts up to 10% with RDX, vaporizes in the detonation wave and does not affect its rate, but if used in higher proportion the deton can be quenched. On the other hand, coarse NaCl (-10+30 mesh) can be added in amts up to 90-95% to fine grained RDX without quenching detonation. Coarse granules of salt allow the deton to propagate between the grains at or near the rate of the pure expl

The observations of Cook resemble the findings of Dolan (Ref 3) with mixts of salt & NG. The high deton velocities obtd with the largest salt granules indicated unimpeded progress of the deton wave. As the granules were decreased in particle size and in-

creased in number, they restricted deton and the velocity fell. Finally as the particles became very fine they vaporized, and the resulting latent heat effect robbed the deton wave of energy
Refs: 1) S. Paterson, 5thSympCombstn (1955), 675-84 2) M.A. Cook, "The Physical Chemistry of Processes at High Pressure", Discussions of the Faraday Society **22**, 203-11 (1956) (Compressibilities of Solids and the Influence of Inert Additives on Deton Vel in Solid Expls) 3) J.E. Dolan, *Ibid*, p 180; *JApplChem* **8**, 471-77 (1958); **9**, 59-64 (1959) & *CA* **53**, 3695, 10763 (1959) 4) M.E. Malin et al, "Particle-Size Effects in Explosives at Finite and Infinite Diameters", *JApplPhys* **28**, 63-69 (1957) 5) Dunkle's Syllabus (1957-58), pp 273-74 6) Cook (1958), 47-49, 211-12

Detonation, Particle Velocity in; and Its Determination. Particle velocity also called material velocity, if designated by u is given by:

$$u = \sqrt{P/\gamma\rho}$$

in an ideal gas, where P = pressure in pounds mass feet/sec², $\gamma = C_p/C_v$ (ratio of specific heat at constant pressure to specific heat at constant volume), and ρ = density in pounds per cubic foot

Shock waves formed by supersonic motion of projectiles are usually weaker than those generated by powerful explosions, which are sometimes called *blast waves* (qv). In a detonation, because of its extreme rapidity and the inertia of the surrounding air, the conversion into air can be completed within the original vol of the expl. Before the air has been forced into motion the pressure of the gases may reach 10⁵ atm. The consequent extremely steep pressure gradient in the expl-air boundary layer leads to formation of a compression shock wave which propagates thru the atm with a very high initial vel. In such compression shocks in air, the particle velocity makes the major contribution to the momentum. On the other hand, in weak shocks the greater part of the momen-

tum is due to static pressure (Ref 3)

Boyle et al (Ref 5, p 855) stated that direct measurements of particle velocity, density and pressure are not feasible at present and the indirect methods must be used. They describe a method using determination of the shock velocities in an explosive (such as Comp B) and in a Plexiglas plate placed in contact with the explosive [See under "Detonation (and Explosion), Pressure of"]

In the discussion which followed the presentation of Boyle et al paper (Ref 5), Dr A.N. Dremin of Institute of Chemical Physics, Moscow, stated that Zavoyskii suggested a direct magnetic method for measurement of particle velocity behind the shock front in the transition region. A metal foil (ca 0.03 mm in thickness) is placed in the explosive to test and the charge is then placed in the magnetic field. On detonation of charge the foil moves behind the shock front with particle velocity, and the potential on its end is recorded on an oscilloscope. It is claimed that this method has a better precision than the "shock-impedance method"

Viard (Ref 2) reported measurements of the particle velocity thru the reaction zone of an aluminized expl. He used a flash radiographic technique in which lead foil was placed across the chge at ca 45° from the normal and passing thru the chge axis. By flashing the X-ray at the instant the deton wave struck the foil, by observing the shape of the foil, and by applying the appropriate geometry, a constant particle velocity was detd

See also under "Detonation, Chapman-Jouguet Parameters in"

Refs: 1) A. Haid, "The Distant Effects of Detonation", *Explosivst* **3**, 9 (1955) (PA Translation No 5 by Dr George H. Loehr, 1956) 2) M.J. Viard, *CR* **244**, 61 (1957) 3) Dunkle's Syllabus (1957-58), 14, 50-53 4) Cook (1958), 80 5) V.M. Boyle et al, "Pressure Measurements During Shock Initiation of Composition B", 10th Symp-Combstn (1965), 855-61

Detonation, Pauli Exclusion Principle in. It is described by Cook (1958), under "Properties of Solids under Explosive Attack", p 209

Detonation, Peak Pressure in. See under Detonation (and Explosion), Pressure of

Detonation, Peak Pressure in Air Blast. See Vol 2 of Encycl, p B181-L and Table on p B182

Detonation (and Explosion), Penetrating- or Jet-Piercing Theory of Apin. Accdg to Apin (Ref 6) the classical hydrodynamic theory of the mechanism of propagation of deton by the impact of a shock wave on neighboring particles of the expl, while theoretically correct, cannot be reconciled in practice with a number of facts. While it is easy to apply hydrodynamic theory for deton of gaseous mixts, it is not clear how a shock wave can create in condensed systems such an intense chemical reaction that it is capable of maintaining the propagation of deton wave in powdered materials contg up to 90% of air spaces. It is also hard to explain the relation betw velocity of deton, density of chge and the size of crystals and spaces betw them. The hydrodynamic theory does not take into consideration physical props of substances, such as state of aggregation, structure, hardness, elasticity, viscosity, etc and for this reason attempts to apply its formulae for calcns of deton velocities were unsuccessful

The importance of physical props of expls in detons may be seen from the following facts:

- a) Chemically homogeneous expls of fine crystalline structure, compressed to certain density are more sensitive to deton by initiating agents than the same substances of coarser cryst structure but of the same density (as for example, in cast expls)
- b) Some NG contg expls would not detonate when in solid, dense mass without air spaces, but would readily detonate if pulverized

c) Deton velocity usually increases with an increase in density, but only within certain limits, because further increase of density might cause decrease of velocity and finally bring it to zero ("dead pressing"). It is possible sometimes, by using a larger diameter charge or stronger confinement, to shift "dead-pressing" to higher densities, but not to eliminate it altogether

Hydrodynamic theory of deton did not explain the above properties

Vieille, Kast and Schmidt (Refs 1, 2 & 3) presumed that in some cases the deton may be accompanied by a so-called *explosive combustion* (vzryvnoye goryeniye in Rus) during which the hot gaseous products of combustion penetrate into spaces between particles of expls and ignite their surfaces. This assumption was used in 1940 by Apin (Ref 4) who proposed the theory of deton called in Rus "struychato-proboynaya". It can be translated as "piercing-stream theory", but accordg to Dunkle, the term *penetrating- or jet-piercing theory* is preferred (Ref 12)

Apin suggested that deton, in general, is always "explosive combustion" of particles of an expl. It is easy to apply this hypothesis to cases of powdered substances because they consist of separate grains, each surrounded by air or other gas and it is easy to ignite each particle by the flame of a neighboring particle. When it comes to condensed expls (such as NG, Gelatin Dynamites, cast TNT), which have only very small air spaces, Apin explained the deton as follows: The particles of expl near the initiator become ignited (explosively) and penetrate (pierce) in the form of extremely hot and rapid moving streams (jets) in all directions, forming sort of channels. While moving, the streams ignite explosively, one by one, the particles encountered on their way

Apin's theory explains some expl phenomenon which previously could not be understood. For example, why aged Gelatin-dynamites (See Ageing of Dynamites in Vol 1 of Encycl, pp A110 to A112) are so hard to initiate. This is because, in such expls, there are no air (or gas) spaces betw

the particles and this makes it very difficult for Apin's jets to penetrate thru the mass of expl. If, however, some bubbles of air are introduced (such as by the method of "rejuvenation" described by the late Dr I.A. Grageroff - see Vol 1 of Encycl, p A111-L), the initiation becomes quite easy. Freshly prepd Gelatin-dynamites contain air spaces and that is why they are detond without difficulty (See also Bubbles of Gas in Explosives, Vol 1 of Encycl, p A320-L)

Accdg to Apin's theory, the deton of finely powdered material is easier to achieve than that of coarser material because smaller particles are easier to ignite

Following are some highlights of Apin's theory:

- A) Initial velocity of the hot products of deton emitted from a charge of expl into atmosphere of any gas (or vacuum) is greater than velocity inside the chge (velocity of deton) ($W > D$) (See Note 2 at the end of this item)
- B) Deton velocity is equal to the speed of movement of hot products of reaction thru the mass of explosive (See Note 3)
- C) During deton, the hot products of reaction pierce the unexploded portions of expl and this is supposed to be possible because the pressure in the cross (transverse) sections of the deton wave is not evenly distributed
- D) The presence of pores in the mass of explosive facilitates the penetration of hot gaseous products of deton along the charge
- E) Speed of penetration inside a condensed expl chge (deton velocity) is smaller than in the outside gases or in vacuum on account of braking effect of the expl
- F) Chemical reaction inside the detonating wave consists mostly of expl combustion of solid grains or liquid droplets, starting from their surface
- G) It is presumed that hot products of deton not only penetrate thru the mass of an expl, but they also pulverize it (in case of solid expls), or break it into microscopical droplets (in case of liquid expls)
- H) Scattering of an expl during deton may be explained by the uneven mechanism

of reaction and incompleteness of combustion on the transverse section of the detonation front (Ref 5)

I) The shape of the surface of detonation front is irregular (hilly) in appearance with sharp streams sticking out

J) Detonation velocity is on the average stationary but not exactly uniform in all sections of the charge. Many conditions, such as density, diameter of the charge, size of particles, confinement, etc, influence the velocity

K) Initiation of detonation (by means of a blasting cap or detonator) has piercing-stream character. When initiation is achieved, the combustion (or deflagration) may turn into detonation under certain conditions (such as increase in pressure, etc (Ref 6) (See also Ref 7)

Note 1: Accord to Dunkle (Ref 12): "The perceptiveness of the author (Apin) of this article (meaning Ref 6) over 20 years old is amazing. The idea that the detonation front is heterogeneous and of rough surface even in condensed-phase explosives is very much in favor now. Several papers and discussion at the 7th Symp Combustn, August, 1966 in Berkeley, Calif bore on this point"

Note 2: Dunkle (Ref 13) made the following remark: "With reference to (A), see 'Jetting' at the end of charge (Ref 8, pp 286-87 & 343-44 and Ref 10, p 24b). By means of microsecond framing camera photography, Udy & Cook (Ref 9) observed a very highly luminous region propagating from the ends of charges when the detonation wave emerged into the air. The highly luminous region became separated from the detonation products and in many instances propagated for distances of over 50 cm at high velocities (See Detonation, Plasma in). Its velocity was usually slightly higher initially than the detonation velocity"

Note 3: Dunkle (Ref 13) also made the following remark: "With reference to (B), it is hard to explain how the particle velocity (u) (the rate of advance of the material) could equal the wave velocity (D) (the rate of advance of the wave front).

In C-J detonation (D) is about four times (u)"

Andreev & Chuyko (Ref 11) noted that:

A. At low pressures the mass burning rate of an explosive is the same whether it is highly compressed or at a low density and porous

B. There is a "feedback" between burning rate and pressure rise. Pressure rise:

a) Accelerates the combustion, either by moving the high-temperature region toward the burning surface, thereby heating the latter; or favoring the dynamic-pressure dependent penetration of hot gases into the porous substance

b) It is in turn steepened thru the proportionality of dynamic pressure rise to the square of the combustion rate

C. In low density powdered (or porous) explosives, there are two main opposing effects: "dilution" and "penetration":

a) Dilution of the explosive by an inert pressurized gas (such as nitrogen) can decrease the over-all detonability of the mixture

b) Penetration of the porous structure by the hot gases ignites a thick layer of suspended particles, thus increasing the amount of material burning per unit time

D. At high pre-pressures, dilution becomes more important. It more or less "neutralizes" the effect of penetration by the hot gases, exerts a stabilizing action, and at 1000 atm, assumes the dominant role

See also Detonation of Powdery Explosive Charges

Mechanism of detonation accord to Apin's theory is described in Refs 6, 7, 7a & 9a

Refs: 1) P. Vieille, MP **4**, 20 (1891)
 2) H. Kast, SS **15**, 195 (1920) 3) A. Schmidt, SS **33**, 312 (1938) 4) A. Ya. Apin; Dokl-AkadN **24**, 992 (1939) & Sbornik Ref Khim-OtdAkadNauk 1940 & 1941 5) B. Rosing & Yu. Khariton, DoklAkadN **26**, 360 (1940)
 6) A. Ya. Apin, DoklAkadN **50**, 285-88 (1945); CA **44**, 1032 (1950) & **47**, 865 (1953)
 7) A. Ya. Apin & V.K. Bobolev, ZhFi zKhim **20**, 1367 (1946) (Effect of the physical structure and state of aggregation on the deton capacity of expls) 7a) Ibid, Dokl-

AkadN 58, 241-44 (1947) (On the nature of detonation conversion of powdered expls)
 8) Dunkle's Syllabus (1957-58), 286-87 & 343-44 (Jetting at the end of the charge in detonation)
 9) L.I. Udy & M.A. Cook, "Propagation Characteristics of Detonation Generated Plasmas", **AFOSR TN-58-754**, AD 201613, June 1958
 9a) Zel'dovich & Kompaneets (1960), pp 218-22 (Detonative combustion)
 10) Dunkle's Syllabus (1960-1961), p 24b (Jetting in detonation)
 11) K.K. Andreev & S.V. Chuyko, *ZhFizich-Khim* 37, 1304-10 (1963) ("Studies in the Deflagration to Explosion Transition of Explosives 1". "Burning of Powdered Explosives at Constant Elevated Pressures")
 12) C.G. Dunkle, private communication, Silver Spring, Md, Sept 1966
 13) Ibid, Jan 1968

Detonation of Pentolite and Composition B, Electrical Measurements in. R.L. Jameson, described in his paper "Electrical Measurements in Detonating Pentolite and Composition B", presented at the 3rd ONR-SympDeton (1960), Vol 1, pp 120-38, the work conducted at the BRL, Aberdeen Proving Ground, Md

Detonation, Performance and Its Prediction. Accdg to Lothrop & Hendrick (Ref 1), there is a relationship between performance and constitution of pure organic compds. This subject was briefly discussed in Vol 1 of Encycl, p A513-R under Auxoexplode or Auxoplosophore. This relationship suggests that some prediction of performance can be made if structure of expl is known (See also Plosophores in Vol 1, p A514-R)

Accdg to Dunkle (Ref 2, pp 356-69) the prediction of the quantity of energy available from an explosion can be done if its heats of expln and of deton are known. They can be either determined experimentally or calcd, as shown under Detonation (and Explosion), Heats of. These heats are main factors in the ballistically important parameters, impetus & specific impulse and have strong influence on blast potential and brisance (See also Vol 2, p B265-L)

Dunkle also discussed (Ref 2, pp 369-71) prediction of armor penetration
Refs: 1) W.C. Lothrop & G.R. Hendrick, *ChemRevs* 44, 419-45 (1949)
 2) Dunkle's Syllabus (1957-1958), 356-71 (Performance predictions)
 3) C.L. Mader, "Detonation Performance Calculations using the Kistiakowsky-Wilson Equation of State", Los Alamos Scientific Laboratory Report **LA-2613**, Jan 1961
 4) M. Lutzky, "The Flow Field Behind a Spherical Detonation in TNT, Using the Landau-Stanyukovich Equation of State", USNavalOrdnanceLaboratory, White Oak, **NOLTR 64-40**, Dec 1964
 5) C.G. Dunkle, private communication, Jan 1968

Detonation, Perturbation Theories. W. Fickett in "Detonation Properties of Condensed Explosives Calculated with an Equation of State Based on Intermolecular Potentials", Los Alamos Scientific Lab Rept **LA-2712** (1962), pp 34-38, discusses **perturbation theories** as applied to a system of deton products consisting of two phases: one, solid carbon in some form, and the other, a fluid mixt of the remaining product species. He divides these theories into two classes: *conformal solution* theory, and what he chooses to call *n-fluid* theory. Both theories stem from a common approach, namely, perturbation from a pure fluid whose props are assumed known. They differ mainly in the choice of expansion variables. The conformal solution method begins with the assumption that all of the intermolecular interaction potentials have the same functional form. To obtain the equation of state of the mixt, some reference fluid obeying a common reduced equation of state is chosen, and the mixt partition function is expanded about that of the reference fluid

The n-fluid theories have received wide attention. As in the conformal solution, it is assumed that the props of any pure fluid with given pair potential are known. The principal differences are in the choice of expansion variable and of the reference fluid. The expansion is made in the differences betw the individual pair-potential functions and the potential function of the reference fluid. These functional differ-

ences are treated as the variables of the Taylor series. As in the conformal solution theory, the expansion is exact, but only the first-order coefficients can be expressed entirely in terms of the macroscopic props of the reference fluid. The form of the expansion is then generalized to a linear combination of expansions about a set of ref fluids whose max number is equal to the number of different pairs of components. The coefficients & the potentials of the ref fluids are then chosen so that first-order terms of the expansion vanish

The equations of state and expansion functions for the perturbation theories are found in paper of Fickett

See also Detonation, Longuet-Higgins Theory and Detonation, Pseudopotential Theories

Detonation (and Explosion), Phenomena Accompanying It. Cook in Chapter 7 of his book, pp 143-71 discusses the following phenomena accompanying detonation:

- a) Ionization and Free Electrons in Flames and the Detonation Reaction Zone (pp 143-44)
- b) Measurements of Electron Densities in the Detonation Reaction Zone of Solid Explosives (pp 144-50)
- c) Ionization and Luminosity Zones in Gaseous Detonations (pp 150-53)
- d) Electrical Potentials and Conductivities in Media Surrounding Detonation (pp 153-59)
- e) Magnetic Fields in Induction Zone (p 159)
- f) Electromagnetic Radiation from Detonations (pp 159-63)
- g) Free Electrons in Reaction Zone and Mechanism of Detonation (p 164)
- h) Thermal Current at the Wave Front in Granular Explosives (pp 164-65)
- i) Thermal Current in Gaseous Detonations (pp 165-66)
- j) Whence Free Electrons in Detonation (pp 166-70)
- k) Photographs of Heat Pulse in Composition B (p 170)

On p 171 are given 12 references

In our compilation there are described the following items, which belong to phenomena accompanying detonation and explosion:

- 1) Detonation (and Explosion), Electrical, Electromagnetic and Magnetic Effects Accompanying It
- 2) Detonation (and Explosion), Heat of, etc
- 3) Detonation, Laser in
- 4) Detonation (and Explosion), Luminosity (Luminescence), Produced on
- 5) Detonation (and Explosion), Mechanical Effects of
- 6) Detonation, Plasma in
- 7) Detonation (and Explosion), Pressure of

Detonation (and Explosion), Piercing-Stream Theory of Apin. See Detonation (and Explosion), Penetrating- (or Jet-Piercing-) Theory of

Detonation, Pin-Oscillograph Method in. See Ref 36, p 29-31 under Detonation (and Explosion), Experimental Procedures

Detonation, Plane- and Spherical-Fronts. See under Detonation, Spherical- and Plane-Fronts

Detonation, Plane- and Spherical-Waves. See Detonation, Spherical- and Plane- Waves

Detonation, Plasma in. As described by Dunkle:

A plasma is an appreciably ionized gas (about 1% or more) having no net charge, and may have a wide range of densities. Plasmas are of particular interest because of the possibility of initiating nuclear fusion in them, but they also appear in such phenomena as a neon sign, a lightning stroke, the ionosphere about the earth, shock waves, and the compressed layer of hot gas about an object entering the earth's atmosphere

They appear in flames and detonation waves. It seems well established that free radicals and ions are present at well over equilibrium concentrations in flames (Ref 1). The ions appear to be produced not by thermal processes but by chemical factors which cause abnormal electronic excitation

Cook attributes the "flashacross" during the DDT (Deflagration to Detonation Transition), in which the shock front in an explosive is overtaken by the combustion

front just behind it, to the sudden generation of a plasma (Ref 13, p 832). He concludes from the high concentration of ions and the rapid rate of recombination, that the plasma has about the same depth as the reaction zone. The conductivity of the detonation head is utilized in measuring detonation velocities and influencing the propagation of the wave (See also under *Detonation (or Explosion), Electrical, etc Effects Accompanying*)

The propagation of plasma from the end of a cylindrical charge when the detonation wave emerged into the air was noted under *Detonation, Jetting in*. Cook found that in explosions of a liquid explosive within a glass beaker, the latter did not expand or break until arrival of the detonation products after passage of the plasma, thus indicating that external pressures exerted by it were small. The plasma did not expand significantly when it left the top of the beaker but showed a remarkable tendency to hold together. The plasma exhibited pulsations and it was concluded that an adhesive attraction exists in it thru a quasi-lattice structure (Ref 11)

The high degree of ionization in detonation has been attributed to the possibility of existence of the plasma in a metal-like lattice (Ref 12). Electrons normally localized within the core of an ion or atom, and hence exerting no bonding action, may become bonding electrons on being promoted at high temperatures to the plasma state; here they move thruout the lattice and thus contribute to the chemical binding of the whole structure

It was suggested (Ref 14, p 187) that, although the electrons produced within the reaction zone of the detonating charge have an expected life of only about 10^{-8} sec, those formed in the last few molecular layers at the end of the charge are propelled forward into a much-lower-density region as the detonation wave emerges; here the expected life is much longer (Ref 11). The resulting plasma is classed as dilute plasma (one or more free electrons per atom or molecule) in contrast to completely ionized

gas

Effects of a magnetic field on plasma (Ref 2, pp 255-63) have led to some interesting astrophysical speculations (Ref 8, p 388) as well as offering a possible means of controlling nuclear fusion reactions. Extremely high temperatures are reached (Ref 2) thru stabilization of the discharge of an electric arc (Ref 9) by surrounding it with a vortex formed by rotating water in a cylindrical swivel chamber. The plasma consists of ions formed by rapid evaporation, dissociation, and ionization of the water plus the products from the arc itself

Control of the movement of plasma is an object of the science of *magnetohydrodynamics* (MHD) (Refs 3 & 4). Possibility of inhibiting thermal conduction in a plasma by such means (Ref 6) offers hope of reaching even the temperatures required for initiation of nuclear fusion (Ref 7). This leads to another important application of conventional (non-nuclear) explosions, for magnetic fields of the required magnitudes can be produced only by explosive compression of a preexisting field under conditions of flux conservation. Fields of some 12 megagauss have been reached in this way, compared to a maximum of only about 1/4 megagauss by conventional steady-state magnets. These high-strength magnetic fields confine plasma so effectively that 5000 gauss exerts a magnetic pressure of a million atmospheres. Multi-megagauss fields can exert, and conversely withstand, pressures of millions of atmospheres

Accdg to Dunkle (Refs 19 & 20), plasmas come into play in the detonation head and are very important in EBW's (exploding bridge wires) (Ref 18) (See also Addnl Refs A, B, C, D & E)

Refs: 1) H.F. Calcote & I.R. King, "Studies of Ionization in Flames by Means of Langmuir Probes", pp 423-34 in the 5th Symp Combstn (1955) 2) R.M. Patrick & A. Kantrowitz, in the Proceedings of the First Gas Dynamics Symposium (Aerothermochemistry), Northwestern Univ, Evanston, Ill, Aug 22-24 (1955), 255-63 3) L. Spitzer Jr, "Physics of Fully Ionized Gases", Interscience, NY

(1956), 45, 48, 51-52, 60 & 92 4) T.G. Cowling, "Magnetohydrodynamics", Interscience, NY(1957) 5) "Plasma Jets", American Rocket News (S. Calif Section ARS, last issue, April 1957, p 15) 6) Y. Nakagawa, PrRoySoc **240A**, 108-13, Apr 1957 (Experiments on the Inhibition of Thermal Conduction by a Magnetic Field) 7) F.B. Knox, "A Method of Heating of Matter of Low Density to Temperatures in the Range of 10^5 to 10^6 °K", Australian JourPhys **10**, 225-27 (Mar 1957) and 50-5 (Dec 1957) 8) Dunkle's Syllabus (1957-1958), 59, 386 & 388-89 8a) W.H. Bostick, Astrophysical Jour **127**, 237 (1958) (Observations of explosions of high speed plasma in a magnetic field) 9) J.W. Reid, "The Plasma Jet-Research at 25000°F", 22-4, Design 30, Feb 1958 10) L.I. Udy & M.A. Cook, "Propagation Characteristics of Detonation Generated Plasmas", AFOS (Air Force Office of Scientific Research) - TN-58-754, AD 201613, June 1958 11) Cook (1958), 138 & 157-58 12) M.A. Cook & M.S. McEwan, JApplPhys **29**, 1612-13 (1958) ("Cohesion in Plasmas") 13) M.A. Cook et al, "Deflagration to Detonation Transition", pp 820-36 in the 7thSympCombstn (1959) 14) M.A. Cook et al, "Chemical Factors in Detonation-Generated Plasmas", in the 3rdONRSymp-Deton (1960), pp 184-201 15) E.L. Kendrick & E.G. Whitbread, "Detonation Plasma" in the 3rdONRSympDeton, Ibid, pp 202-04 16) Dunkle's Syllabus (1960-1961), pp 24b-c (Discussion on the papers listed here as Refs 10, 12, 15 & 16) 16a) Z.W. Fagg & R. Friedman, Raketnaya Tekhnika No 1, p 122 (1961) (Solid Powders as Sources of Cesium Plasma) 17) R.C. Good Jr, AIAA-Jour, Vol 1, No 6, 1397-1402 (June 1963) ("Destructive Effects of Plasmas Generated by Exploding Wires") 18) W.G. Chace & H.K. Moore, Eds, "Exploding Wires", Plenum Press, NY, Vol 3 (1964), pp 9-22 (Some exptl results of exploding wire research and their application in plasma physics); 118-20 & 122 (Plasma jet) 19) Dunkle, private communication, June 1967 20) Ibid, January 1968

(See also Addnl Refs)

Addnl Refs on Plasma:

A) C. Longmire, J.L. Tuck & W.B. Thompson, "Plasma Physics and Thermonuclear Research", Vols 1 & 2, Pergamon Press, NY (1959)

B) F.L. Carf, "Wave Propagation in a Moving Plasma", AmerJPhysics, **29**, 101-07 (1961)

B₁) G. Bekefi & S.C. Brown, "Emission of Radio-Frequency Waves from Plasma", AmerJPhys **29**, 404-28 (1961)

C) S.C. Brown, "Plasma Physics", The Physics Teacher, Vol 2, No 3, 103-10, March 1964 (Paper following in form and substance the "Outline of a Course of Plasma Physics", sponsored by the "Commission on College Physics" and published in the AmerJPhysics **31**, 637-91(1963)

Following is Dunkle's Abstract:

"The fourth state of matter, the "plasma state", although rarely found at the surface of the earth, is the most commonly found state of matter when the known universe is considered. The plasma state, consisting of a neutral collection of electrons and positive ions, may have a very wide range of densities. The production and properties of this state are described. Plasmas are of particular interest now because of the possibility of initiating nuclear fusion in them but they also appear in phenomena ranging from those found in a neon sign, a lightning stroke, the ionosphere about the earth, shock waves, and the compressed layer of hot gas around an astronaut's capsule as he comes back thru the earth's atmosphere"

D) G.R. Seikel, "Plasma", NASA Space/Aeronautics **43**, No 4, pp 40-5 (April 1965). Following is Dunkle's Abstract:

"As appreciably ionized gases, plasmas are a state of matter in the same sense that liquids are melted solids or gases are evapd liquids. In each case, the change in state is accomplished by addn of enough thermal energy to break some organizing bond or binding energy. In the case of plasma, a gas is ionized by breakage of the coulomb forces between the bound electrons and

the nucleus. The energy (of) this first ionization potential of gases is a number of ev, much more than the less-than-one electron volt required for solid and liquid state transitions. And since each electron volt of kinetic temp is equiv to 11600°K, plasmas of any appreciable degree of ionization cannot exist at temps below a few thousand degrees. To be a plasma (an "appreciably" ionized gas), on the order of only 1% of the atoms need be ionized. The un-ionized atoms are then called "neutrals"

In addn, for an ionized gas to be called a plasma, it must have an equal number of pos and neg charges for, by definition, a plasma has no net charge. Regions termed "sheaths", having large (net charges) do develop at the plasma boundaries. Such sheaths are to the plasma what the surface is to a solid or liquid, and their thickness is of the order of the "Debye length"

Note: The **Debye Length** is the distance over which the thermal energy of the particles causes major differences in the pos and neg charge densities, hence the max distance within a plasma that a particular charged (either pos or neg) particle can be "seen". The Debye length is not constant. It increases with temp and decreases with pressure. In atm arcs it is less than a micron. In the ionosphere it is on the order of a mm and in interstellar space it is approx 1 meter

E) G.N. Spokes & B.E. Evans, "Ion Sampling from Chemical Plasmas", 10thSympCombstn (1965), pp 639-49

F) B.E.L. Travers & H. Williams, "The Use of Electrical Probes in Flame Plasmas", *Ibid*, 657-72

G) 4thONRSympDeton (1965) - No papers on Plasmas

H) G. Bekefi & S.C. Brown, *AmJPhysics* **34**, 1001-05 (1966) (Waves & Radiation Processes in Plasma)

I) 12thSympCombstn (1968) (Pub 1969) - No papers on Plasmas

Detonation, Point Initiation of. See under DETONATION (AND EXPLOSION) SPHERICAL

Detonation (Explosion and Combustion), Point Source. See under DETONATION (EXPLOSION AND COMBUSTION), SPHERICAL

Detonation (and Explosion), Polytropic Curve, and Polytropic Law. Dunkle (Ref 2, p 184), under the heading "Polytropic Law", explained that a simplified form very useful in expls calcns is obt'd by assuming that the expln products behave as a *polytropic gas*, i.e., an ideal gas having constant specific heats and hence a constant value of specific heat ratio γ . He gives also the *polytropic equation of state*, which we included under "Detonation (and Explosion), Equations of State"

Dunkle also stated (Ref 2, p 186) that it is not surprising, then, that the polytropic equation:

$$P = A(s)\rho^n \text{ or } \ln P/P_0 = n \ln \rho/\rho_0$$

with $n=3$ is found to approximate, as well as more complex equations of state, the actual density-pressure relationship in a detonation. Its plot of $\log P/P_0$ vs ρ/ρ_0 is a straight line of slope 3 passing thru the origin. It appears that such a line represents fairly well an "averaged" relationship for detonations in real fluids which have covolumes, than, for example, Abel's equation of state. Cook has shown (Ref 1) that the covolume is not in fact constant but decreases at high pressures, indicating that the molecules are "squeazy" rather than rigid spheres

Dunkle also discussed in Ref 3, p 15e some modifications of the polytropic equation, some of which are included under Detonation (and Explosion), Equations of State

The work of Apin et al (Ref 4) on calcn of exponents of a polytropic curve of explosion products of condensed expls was summarized by A.G. Streng in *CA* **56**, 11871-72 (1962), as follows: The adiabatic curve of explosion products at the front of a detonation wave may be described by the polytropic law: $p = A v^{-n}$. The exponent n depends mainly on the compn of the explosion products; the influence of temp

and pressure may be neglected. Expts performed with explosive compds and mixts showed that over a wide range of temps and pressures of detonation, the exponent of the polytropic curve of explosion products may be obtained from the values of exponents of the individual reaction products: $n^{-1} = \sum \beta_i n_i^{-1}$ where β_i is the mole part of a given explosion product, and the values of n_i are as follows: $n_{H_2O} = 1.9$, $n_{N_2} = 3.7$, $n_{CO} = 2.85$, $n_C = 3.55$, $n_{CO_2} = 4.5$, $n_{O_2} = 2.45$

Refs: 1) M.A. Cook, "An Equation of State at Extremely High Temperature and Pressure from the Hydrodynamic Theory of Detonation", *JChemPhys* **15**, 518-24 (1947) & **16**, 554-55 & 1165 (1948) 2) Dunkle's Syllabus (1957-1958), 184-87 3) Dunkle's Syllabus (1960-1961), p 15e 4) A.Ya. Apin et al, *ZhPrikladMekh i TekhFiz* **1961**, No 5, pp 117-18 & *CA* **56**, 11871-72 (1962) (Calculation of exponents of a polytropic curve of explosion products of condensed explosives)

Detonation (and Explosion), Polytropic Curve Exponents. See Ref 4 in previous item

Detonation; Post-, After-, or Delayed Reaction in. See Delayed-, After-, or Post-Reactions in Detonation

Detonation of Powdery Explosive Charges.

The discussion given by Zel'dovich & Kompaneets (Ref 6), based on investigations by Apin and Bobolev (sometimes spelled Bobylev) (Ref 1-4), may be summarized as follows:

If particle sizes of powder are smaller than the critical diameter, each grain taken separately is not capable of detonation, but if the whole charge is properly initiated, each single particle somehow helps another to react rapidly and to completion in the detonation wave. If, however, the charge consists of coarse grains whose dimensions are larger than the critical values, the detonation does not proceed discretely grain by grain due to the interaction between the grains during the reaction

Apin & Bobolev (Refs 1-4) developed the concepts of the deton of powders in detail by the device of expl burning or granular combustion. Gas jets penetrate the pores between separate particles of the expl substance and ignite them. Each particle as it burns is surrounded by expln products where the combustion rate depends on the pressure of the surrounding gas.

The deton vel of powders is a smooth function of the granular density or of the pressing density and for a large chge diam it does not depend on the dimensions of the expl particles. It is precisely from the dependence of D on ρ for powders that one can establish the equation of state of the products. Thus, it would not be correct to state that in expl combstn the deton vel is equal to the vel of the gas jets which penetrate the powd. In actuality, upon detonation by the mechanism of explosive combustion, the deton vel is detd by the equation of state. That is, by the pressure of the expln products according to hydrodynamic theory, while the vel of the gas streams in this case is automatically established equal to the deton vel

For powders, such as Lead Azide (LA), the limiting diam is small and it is possible to have conditions such that each particle of the powder taken separately is able to detonate. In this case the deton wave being propagated represents an aggregate of deton waves being propagated in separate crystals and which are transmitted from one crystal to the next

Thus, when detonation is not by the mechanism of expl combustion the hydrodynamic theory is not obeyed, while with expl combstn it is fulfilled

See also Detonation (and Explosion), Penetrating or Jet-Piercing Theory of Apin *Refs:* 1) A.Ya. Apin, *DoklAkadNauk* **24**, 922 (1939) (On the mechanism of expl dissociation of Tetryl) 2) *Ibid*, **50**, 245 (1945) (On the detonation and explosive combustion of explosives) 3) A.Ya. Apin & V.K. Bobolev, *ZhFizKhimii* **20**, 1367 (1946) (The effect of the physical

structure and the state of aggregation on the detonating capacity of explosives)
 4) Ibid, DoklAkadN 58, 241 (1947) (On the nature of detonating conversion of powdered explosives) 5) Cook (1958) - not found 6) Zel'dovich & Kompaneets (1960), 218-19

Detonation (or Explosion), Power; Available Energy (or Maximum Available Work Potential) and Strength in.

Barnett (Ref 2) defined "power" as "capacity of doing work" and this corresponds to the Rus word "rabotosposobnost'", as defined in Ref 21, p 92 and to the French terms: "rendement pratique" ou "effet utile" (See under Potential in Ref 23, p XX) and "coefficient d'utilisation pratique", abbr CUP (Ref 23, p IX & Ref 26, p C390). See also "produit caractéristique de Berthelot", described under Berthelot's Characteristic Product in Ref 25, p B105-L and "essai au mortier éprouvette", described as Mortar Test in Ref 23, p XIX. In German the Engl term "power" corresponds to "Sprengwirkung" and has been detd by "Bleizylinderprobe nach Trauzl" (Ref 6, p 361 & Ref 9, p 111) or by "Kraftzahl (KZ) Probe of Neubner" (Ref 9, p 113 & Ref 18, p Ger 102-R). Italian tests are described in Refs 10 & 11; Spanish tests in Refs 7, 8 & 12 and Russian tests in Refs 20 & 22

Of these tests the "Trauzl Test", also known as "Lead Block Expansion Test" is one of the oldest and it became, since 1903, an official test in most of the countries of the world (except GtBritain & USA). Accdg to Pérez Ara (Ref 8, p 113) this test was invented by Beckerhinn in 1877, but accdg to Stettbacher (Ref 6, p 362) an Austrian scientist Trauzl described the method in 1883. In France the test has been used in a modified form known as "coefficient d'utilisation pratique" (CUP) and is described in Ref 23, pp IX-X & XXV-XXVI and in Ref 26

Ballistic Pendulum Test, described briefly in Ref 23, pp VII-VIII, has been used in USA and until 1949 in GtBritain (Ref 13, p 185). Ballistic Mortar Test, described briefly in Ref 23, p VII is used now in Gt-Britain (Ref 13, pp 185-86)

Besides the above listed tests there are the Cratering Test (Ref 23, p X), Quinan Test (Ref 23, p XXI & Ref 26). Guttman Test (Ref 8, p 118) and Mortar Test (Ref 23, p XIX & Ref 6a, p 66). They are not official tests

Cook (Ref 17, p 271-L) defines power as "the rate of doing work", but it may also be defined as "energy divided by time", since "power multiplied by time is energy". A watt is a unit of power and watt-hour is a unit of energy

The Russian word "rabotosposobnost'" or "capacity of doing work" corresponds to Engl "power", while the word "sila" (pronounced sceela) means "force" and can also be called "strength" (See Ref 20, p 644-45; Ref 21, p 92 & Ref 22, p 466). For practical determination of "rabotosposobnost'" one uses in Russia: Trauzl Test (Ref 20, p 647 & Ref 22, p 466), as well as Ballistic Pendulum Test and Ballistic Mortar Test (Ref 22, pp 469-74). One can also use the Cratering Test (Ref 22, p 474) and a method based on the measurement of shock pressure (Ref 22, p 475). In the book of Baum et al (Ref 20, p 645) it is stated that "sila" (F) can be calcd from the equation:

$$F = nRT_H$$

where: n = number of moles of gaseous products formed on detonation, T_H = temperature developed on detonation, and $R = p_0 v_0 / 273$. Here p_0 = atmospheric pressure and v_0 specific volume

Cook (Ref 17, p 36) designates the available energy as A, and states that this property, as well as the heat of explosion Q, and the ratio A/Q are the important quantities determining the total blast or "available work potential" or "available energy". The theory is presented in Chapter 11 of Ref 17, pp 265ff and is considered more reliable than experimental procedures, at least for CHNO expls. The experimental procedures referred to by Cook for determination of (A) include Trauzl Block Test and Ballistic Mortar Test. New methods have been proposed, such as determination of peak pressure or/and total energy &

impulse of the underwater shock wave of a given weight of explosive at a fixed distance from the point of detonation. The quantities determined by peak pressure test may then be related to the available energy of the source by the application of the principles of underwater shock-wave propagation, such as described in the book of R.H. Cole, "Underwater Explosions", Princeton University Press, NJ (1948)

A modification of the above underwater method studied by Cook (p 37) is the measurement of the "spall-dome velocity at the surface", caused by explosion at a fixed distance beneath the surface. The method (which is not described in Cook's book) is best applied by use of calibration curves employing as suitable standard a selected explosive. It has been claimed that the method is reproducible within 5 to 10% and gives data generally in fair accord with expectations from theoretical calculations, provided the depth and extent of the pond are sufficient to avoid shock reflections. In many cases, however, there was a necessity of taking into consideration the rate of evaporation of water at the gas bubble-water interface (Ref 17, p 37)

Accdg to Cook (Ref 17, p 265), in borehole, well drilled hole, and tunnel blasting, the effective initial state of the detonation products in the work integral (as was first derived by A. Schmidt):

$$A = -\int_{v_1}^{v_f} p dv = Q - q \quad (\text{Cook's Eq 11.1})$$

is that corresponding to uniform filling of the blast hole before any movement of the burden has taken place. Here A is the maximum available work, v_1 = specific volume in this initial state, v_f that of the final state in the work integral, usually the sp vol at which the pressure p is 1 atm, Q = heat of explosion and q = heat content of gases in the final state; Q & q being referred to the initial temperature T_1

Symbol A_3^0 is for the "thermodynamic maximum available work" when v_{f_0} is the sp vol at $p_{f_0} = 1$ atm. If $v_1 > v_3$, or/and if $v_f < v_{f_0}$, A is less than A_3^0 , even though free expansion from v_3 to v_1 will transfer no heat from the gases to the burden, be-

cause the mechanical efficiency is then reduced. However, for ratios of v_1/v_3 no greater than ca 2.0, the difference

$A_3^0 - A$ is relatively small for high-density explosives. That is, one finds that p-v conditions in most HE's are such that, if $v_1 \leq 2v_3$, the mechanical efficiency is generally very high; in fact, theoretically A/Q sometimes exceeds unity by a small amount by the calculated final temperature T_{f_0} dropping below the initial temp of the explosive T_1 , Q being referred always to T_1 (Ref 17, p 65)

Cook (Ref 17, p 268) in applying Eq 11.1 and equations 11.5 and 11.8, which are not shown here, determined values of A_3^0 for a large number of CHNO expls, Dynamites and many other commercial types. In CHNO and other expls generating no free carbon or other condensed products of detonation, the relation A_3^0/Q is only slightly below unity and it is not a serious error to consider $A_3^0/Q = 1$ for expls at loading densities near 1.0

Accdg to Ref 14, p 68 & Ref 26a, p 5-21, "the total work capacity of an explosive is a function of the total available heat liberated at the instant of detonation, but its power is determined by the rate at which the heat energy is liberated. In the past, measurement was made of the maximum pressure developed by detonation and this was considered an expression of the work function of the explosive. However, such tests were made with explosive charges having relatively low loading density values and it was then necessary to calculate by extrapolation the pressure produced by an explosive in its own volume

The heat of explosion can be calculated or determined experimentally in special thick-walled bombs, as described under DETONATION (EXPLOSION, DEFLAGRATION, COMBUSTION AND FORMATION), HEATS OF

Accdg to Cook (Ref 17, p 271), the Trauzl Block Test is a measure of "relative available energy" which corresponds to *strength* and not to *power*. He notes that "there is no reason to believe that *brisance* is *power*", because "brisance seems to be directly related to detona-

tion pressure. It seems therefore, that 'power' and *brisance*, as used by Lothrop & Handrick" (our Ref 10a) "is a misnomer and that *strength* would be a much better designation. As a matter of fact *strength* is the term that has been used in the industry for many years as the factor measured in both the Trauzl block and the ballistic mortar tests". Cook also criticizes the values given by L & H, especially the heat of explosion

Gordon et al (Ref 14a), as quoted from Cook's book (Ref 17, p 271), discussed in detail the Trauzl Test and showed that the work of deformation did not vary linearly with the weight (or energy) of the expl, but instead the volume of expansion (v_m) was related to the weight of expl chge (w) by the equation:

$$w/v_m = a - b \log v_m$$

where (a) and (b) are constants. They showed also that there was an excellent correlation between the (nT) product (or nRT) and the expansion volume. This seemed to indicate that Trauzl Test is a measure of *relative available energy*.

Cook (Ref 17, pp 271-72) has shown that there is a correlation between calcd values (A_3^o) of "maximum available work" (as shown on p 268 of Ref 17), divided by 800 and Trauzl Test values in cc, when divided by 300. It seems that the best correlations were obt'd for Trauzl Test values reported by Neubner (Ref 2a)

The Table given below compares the calcd values of (A_3^o) and experimental values of von Neubner, as taken from Table 11.2, p 272 of Ref 17

Table

| Explosive | $A_3^o/800$ (calculated) | Von Neubner Values |
|-------------|-----------------------------|-----------------------|
| PETN | 16.6 | 16.4 |
| RDX | 16.7 | 16.4 |
| Tetryl | 12.0 | 11.7 |
| Picric Acid | (10.0) | (10.0) |
| TNT | 9.5 | 9.6 |

As result of his investigations, Cook (Ref 17, p 272) came to the conclusion that Trauzl block provides an excellent measure of *available energy*, but unfortunately the method is not as reproducible as one might desire, and, moreover, is too cumbersome for routine work

Taylor & Morris (Ref 5a) quoted from Cook (Ref 17, p 272), have discussed the ballistic mortar presenting calibrations of the mortar in absolute energy units

Similar studies have been carried out by Cook who came to the conclusion that ballistic mortar is not a reliable method for determining field strength of HE's. Nevertheless, the maximum available work (A) in the mortar can be predicted quite accurately by the use of equation 11.8 given on p 268-L of Ref 17 and equation 11.12 given on p 273-R of Ref 17

[See also "Detonation (and Explosion), Impetus and Available Energy in"]

Refs: 1) Marshall **2** (1917), 463 2) Barnett (1919), 178 2a) R. Neubner, SS **23**, 1 (1928) (Trauzl test values for some expls) 3) USBurMinesBull **346** (1931), pp 40-6 (Ballistic Pendulum Test); 46-9 (Ballistic Mortar Test, DuPont Type); 104-06 (Trauzl Test) 4) Marshall **3** (1932), 133 5) Vennin, Burlot & Lécorché (1932), 50-3 & 72-86 5a) W. Taylor & G. Morris, TrFaradSoc **28**, 545 (1932) 6) Stettbacher (1933), 361-65 (Die Trauzl'sche Bleiblockprobe); 368-69 (Ballistischer Pender und Mörser) 6a) Pepin-Lehalleur (1935), 64-8 (Potentiel ou Effet utile as determined by Bloc de plomb, Épreuve de tir au mortier, Pendule balistique & Essai dans la terre) 7) Vivas, Feigenspan & Ladreda, Vol 4 (1944), 111-12 (Prueba Trauzl para determinar la fuerza); 116-17 (Medida del potencial o Efecto útil de un explosivo en el Mortero probeta); 117-18 (Medida del potencial o Efecto útil de un explosivo en tierra) 8) Pérez Ara (1945), 113-21 (Valoración comparativa de la potencia by the following methods: Prueba de Trauzl, Pequeña prueba de Trauzl, Aparato de Quinan, Aparato de Guttman, Pendulo balístico and Mortero probeta de

- Nobel) 9) Stettbacher (1948), 111-12 (Die Bleizylinderprobe nach Trauzl); 113 (Kraftzahl as formulated by Neubner)
- 10) Caprio (1948), 35 (Forza dell'esplosivo); 50-53 (Saggio al blocco di piombo o Saggio Trauzl) 10a) W.C. Lothrop & G.R. Handrick, ChemRev **44**, 419 (1949) 11) Belgrano (1952); 23-28 (Metodo del Trauzl or Metodo del blocco di piombo); 28-30 (Saggio del Trauzl nella terra) 12) Stettbacher, Pólvoras (1952), 142-45 (Ensayo con el cilindro de plomo de Trauzl); 145 [Índice de fuerza (IF) de Neubner, called in Ger Kraftzahl (KZ)] 13) Taylor (1952), 185-86 [Measurement of power (or strength) of HE's by Trauzl Test, Pendulum Test and Ballistic Mortar Test] 14) Anon, "Military Explosives", **TM 9-1910** (1955), 68-71 (Definition of "power" and description of tests) 14a) W.E. Gordon et al, IEC **47**, 1794 (1955) (Detailed discussion on Trauzl block method) 15) J.F. Roth, Explosivst **1957**, 161-76. PicArns Translation **No 30**, by Dr G.R. Loehr (1959) (Ballistic methods for measuring expl power and deton shock) 16) Dunkle's Syllabus (1957-1958), p 257 (Discussion on expression nRT_v misnamed "power" or "explosive force", whereas a better name is "impetus") [See "Detonation (and Explosion), Impetus and Available Energy in] 17) Cook (1958), 36-37 (Available energy or maximum available work potential); 265-68 (Maximum Available Work and Peak Blast Pressure); 268-70 (Approximate Evaluation of Maximum Available Work A_3^0); and 271-73 (Trauzl Block and Ballistic Mortar) 18) Fedoroff et al, PATR **2510** (1958), p Ger 102-R (Ger methods for detn of power, including Kraftzahl) 18a) Tomlinson & Sheffield, PATR **1740**, Revision 1 (1958) (Ballistic Mortar Test and Trauzl Test) 19) R. Martin & H.J. Yallop, JApplChem **9**, 310-15 (1959) (Correlation of expl power with molecular structure) 20) Baum, Stanyukovich & Shekhter (1959), 439 & 649 (Ballistic Pendulum Test); 644 ("Rabotosposobnost' " - ability to perform work); 645 ("Sila", meaning "force" and designated as F); 647 Trauzl Test) and 649 (Cratering Test) 21) Bandurin & Rukin (1959), 92 (Rabotosposobnost' is detd by Trauzl Test or by Ballistic Pendulum Test) 22) Andreev & Belyaev (1960), 466-69 (Trauzl Test); 469-71 (Ballistic Pendulum Test); 471-74 (Ballistic Mortar Test); 474-75 (Cratering Test); 475-76 (A method based on measurement of shock wave pressure) 23) PATR **2700**, Vol 1 (1960), pp VII-VIII (Ballistic Mortar & Ballistic Pendulum Tests); IX-X (French test "Coefficient d'Utilization Pratique, abbr CUP); IX (Mortar Test); XX (Potential); XX (Power); XXI (Quinan Test); & XXV (Trauzl Test) 24) Dunkle's Syllabus (1960-1961), p 22d & 22e [Discussion on ballistic mortar and ballistic pendulum. In both cases the angle of recoil (A) is measured and the "power" (P) expressed as: $P = 100(1 - \cos A) / (1 - \cos A_0)$, where (A_0) is the angle of recoil of reference explosive] 25) PATR **2700**, Vol 2 (1962), p B6-R (Ballistic measuring methods); B105-L (Berthelot Characteristic Product) 26) PATR **2700**, Vol 3 (1966), p C390 (Coefficient d'utilisation pratique; Fr test for detn of power); pp C493-R & C494-L (Compression test of Quinan) 26a) Anon, "Military Explosives", **TM 9-1300-214 & TO 11A-1-34** (1967), p 5-21 (Power and heat of expln); 5-21 & 5-23 (Ballistic pendulum); 5-23 & 5-24 (Trauzl test); and 5-28 & 5-29 (Cratering effect) 27) C.G. Dunkle; private communication, Jan 1968

Detonation, Precursor Shock in Solids.

Accdg to the paper of 1962 by Maček (Ref 14): "The shift of attention to the problem of transition to detonation in solid explosives, about a decade ago, was occasioned by the awareness that the problem may be pertinent to the proper functioning of large rocket propellant grains, and was given additional impetus by the scientific approach to *shock initiation*. From initial qualitative suggestions of Kistiakowsky (Refs 4 & 6) and Ubbelohde (Ref 5) there developed the hypothesis of **precursor shock**, which postulates a sequence of events rather analo-

gous to that which occurs in gases. One may distinguish three steps: (a) rapid increase in pressure behind the burning front, which sends compression waves thru the front into the unburnt explosive; (b) formation of the *precursor shock*, due to coalescence of compression waves, in the unburnt explosive ahead of the flame; and (c) *shock initiation* of the detonation reaction. The sequence will occur only if there is confinement of the gaseous product; the rigor of confinement requisite for transition to detonation will be determined by the strength of the shock necessary to initiate the detonation reaction" (Ref 14, pp 50-51)

The hypothesis was borne out by quantitative studies of the burning of explosives under confinement. Maček & Gipson (Refs 7, 8 & 13) investigated burning of cast Pentolite and DINA, while Griffiths & Groocock (Ref 10) experimented with low-density granular PETN, RDX & HMX

The one-dimensional precursor shock mechanism is sketched in Fig 4 of Ref 14 and is reproduced here. Following ignition (at origin) there is a relatively protracted period during which the pressure is so low that the waves $c(o)$ remain very nearly sonic and the entire charge of explosive essentially uncompressed. The significant acceleration begins at the time t_1 , when the amplitude of compression waves emerging from the deflagration front becomes appreciable; the ensuing growth of a full-fledged detonation wave takes usually less than 100 microseconds. The compression waves converge into a *precursor shock* in a region in the $x-t$ plane determined by the rate of increase of pressure of the product gas which, in turn, depends on the burning rate law, the geometry of the system, and the equation of state of the product gas. The region of shock formation, represented in Fig for simplicity by a single point S, can then be constructed by the "method of characteristics" described in the book of Courant & Friedrichs (Ref 3). The pertinent velocities are given as equations 12, 13 & 14 on p 51 of Ref 14

The central point of the precursor shock mechanism is that the shock wave formed at the point S is assumed to cause detonation in a manner entirely similar to initiation in shock-initiation which can be investigated by gap or impact tests, described on pp 56-60 of Ref 14

Chemical reaction is initiated at S. This is so despite the fact that points of lower values of x have been exposed to high pressures for a longer time. It has been speculated in connection with gaseous systems that the effect may be due to lateral transport losses. The compression process, shown in Fig, consists of two regions: up to the point S the flow is that of a simple (isentropic) compression wave, while beyond S the flow is no more a simple compression and, consequently, there is an increase of entropy across the shock front. The corresponding compression energies are expressed by equations 15 & 16 of Ref 14, p 51:

$$E_{\text{isentropic}} = -\int p dV \quad (15)$$

$$E_H = \frac{1}{2} p_H \left(\frac{1}{\rho_o} - \frac{1}{\rho_H} \right) \quad (16)$$

where: p = pressure (atm), V = volume (cm^3), ρ_o = density at initial condition, and ρ_H = density at shock (Hugoniot) condition

The shock-compression energy given by equation 16 (the *Hugoniot equation*) is larger than corresponding isentropic compression energy. For reasonable eqs of state of solid expls and for pressures of the order of 10^4 atm, the discontinuous increase in energy (and temperature) at the point S may be, accdg to Zovko & Maček (Ref 12a), ca 20%; the resulting increase in reaction rate will be manifold. A consequence of the fact that shock-initiation occurs ahead of other reaction fronts (deflagration and low-order detonation) is that the precursor shock mechanism requires a *backward-moving* detonation front - a **retonation** to propagate from the point S. Such a front was observed photographically by Griffiths & Groocock (Ref 10) (Ref 14, pp 51-2)

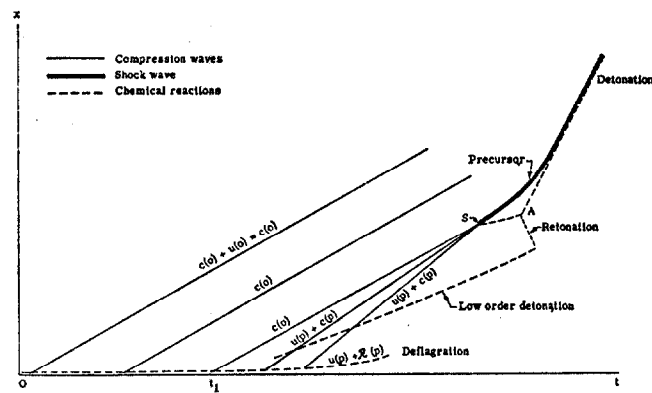

FIG 4 One-dimensional precursor shock mechanism of transition from deflagration to detonation in solids

The cause of failure of less sensitive explosives to undergo transition to detonation within a limited time and under limited confinement may, according to Gipson & Maček (Ref 8), be either a low *burning rate* (in which case the rise in pressure is slow and no precursor shock can form within a reasonable distance), or a low sensitivity to shock. In the latter case the shock may form, but cannot attain sufficient strength before rupture of the casing quenches the chemical reaction (Ref 14, p 52)

As in the case of gaseous systems, the sequence of transition events detailed above presupposes a mechanism of rapid increase of burning rate. In the simple case of a cast expl the mechanism can be provided by the pressure dependence of laminar deflagration rate, as previously discussed by Maček (Ref 7). In most practical cases, however, the explosive is probably not homogeneous and contains some occluded gas. Although it seems doubtful, in the opinion of Maček, that adiabatic compression of occluded gas has any profound effect on detonability of expls and propants, the existence of cracks and pores does furnish an increased burning surface area. Influence of porosity on detonability and flammability was investigated in the 1940's by Andreev et al (Refs 1 & 2) and in the 1960's by Amster

et al (Ref 9), Taylor (Ref 11) and Wachtell & McKnight (Ref 12). They found that a significant increase of pressure will occur only when a mechanism of burning within cracks and interstices becomes possible (Ref 14, p 52)

The value of *precursor shock mechanism* is that it allows the complex problem of transition to detonation, in the first approximation, to be dealt with as a sequence of two simpler processes: formation of a shock in an essentially inert medium and initiation of detonation by shock

See also as separate entries the following related items:

"Combustion, Explosion, and Shock Waves" in Section 1

"Deflagration, Development (Transition) from Combustion (Burning) in Powdered Explosives", Section 1

"DETONATION (AND EXPLOSION), DEVELOPMENT (TRANSITION) FROM BURNING (COMBUSTION) OR DEFLAGRATION", Section 2

"Detonation (and Explosion) Initiation (Birth), and Propagation (Growth or Spread) in Explosive Substances", Section 7

Refs: 1) K.K. Andreev, DoklAkadN **29**, 469(1940) 2) K.K. Andreev, ZhPrikl-Khim **17**, 533(1944) 3) R. Courant & K.O. Friedrichs, "Supersonic Flow and Shock Waves", Interscience, NY(1948),

pp 204ff 4) G.B. Kistiakowsky, 3rdSymp-Combstn (1949), pp 560-65 5) A.R. Ubbelohde, 3rdSympCombstn (1949), pp 566-79 6) G.B. Kistiakowsky, IEC **43**, 2794 (1951) 7) A. Maček, JChemPhys **31**, 162 (1959) 8) R.W. Gipson & A. Maček, NavOrdRept **6867** (March 1960) 9) A.B. Amster et al, AmerRocketSocJ **30**, 960 (1960) 10) N. Griffiths & J.M. Groocock, JCS **1960**, 4154 11) J.W. Taylor, 3rdONRSympDeton (1960), pp 77-87 12) S. Wachtell & C.E. McKnight, 3rdONRSympDeton (1960), pp 635-58 12a) C.T. Zovko & A. Maček, 3rdONRSymp-Deton (1960), pp 606-34 13) R.W. Gipson & A. Maček, 8thSympCombstn (1962), pp 847-54 14) A. Maček, ChemRevs **62**, 50-2 (1962)

Detonation, Predetonation Phase. This is an intermediate phase in the DDT (Deflagration to Detonation Transition) between deflagration (or combustion) and detonation

Oppenheim (Ref 3, p 475) describes how during this phase a combustion front is accelerated by a shock process until the shock front is overtaken and a (CJ) Chapman-Jouguet detonation sets in. The detonation wave is a combination of a shock and combustion front, and has a constant width on the time-distance plot. Passage thru the intermediate state would require the attainment of extremely high peak pressure, and of wave-front velocities above the CJ value. Oppenheim quotes (Ref 3, p 476) some exptl evidence of these phenomena

A *supervelocity (hypervelocity)* process during the DDT has been observed by several investigators (Refs 4, 9 & 10). It is described under "Detonation, Supervelocity (or Hypervelocity) in"

Accdgd to Dunkle (Ref 12), when a detonation encounters an SPHF ("shock-pass-heat-filter"), [described in Ref 40 under DETONATION (AND EXPLOSION), EXPERIMENTAL PROCEDURES and briefly in the book of Cook (Ref 6, p 83)], a barrier which stops the heat wave but lets the shock wave pass thru, a *predetonation* regime builds up again behind the shock,

and develops a combustion wave which overtakes the shock front by *flash-across* to set up again the full scale detonation. The flash-across phenomenon is described by Cook under "heat pulse" (Ref 6, pp 87-9). It is also briefly described under Detonation; Flash-Across, Heat Pulse and Hypervelocity in

During the 7thSympCombstn there was considerable discussion of *predetonation* phase during the DDT in which the combstn wave is still slower than the shock front. This regime which Pangburn (Ref 7, p 789-96) called "pseudo-detonation", was named by Troshin (Ref 8, pp 866-75), "a latent combustion phase"

A monograph of Shchelkin & Troshin (Ref 11) is based on studies at the Institute of Chemical Physics, Academy of Science, Moscow during the period 1952-1962, of theoretical analyses of detonation, deflagration, flame acceleration, nonsteady-state double discontinuities, and high-frequency oscillations in forced-combustion chambers. The book has been translated into English (See Ref 11a)

In the chapter dealing with nonsteady-state double discontinuities, it is shown that a combustion region in which a shock wave precedes the flame front can exist, and that arbitrary constant burning velocities ranging from maximum deflagration to minimum detonation velocities can be established in this regime. The feasibility of such a regime is proved by analysis based on a generalized Hugoniot equation Refs: 1) W.C.F. Shepherd, Nature **160**, 92-3 (1947) & CA **41**, 7753 (1947) (Speed around the initiating point of the detonation wave in HE's) (Predetonation of cylindrical chges of Tetryl & TNT) 2) A.S. Sokolik, ZhEksper i TeoretFiz **21**, 1164 & 1176 (1951) (On the mechanism of predetonation flame acceleration) (Remark on the paper by Ya.B. Zel'dovich 3) A.K. Oppenheim, "Gasdynamic Analysis of the Development of Gaseous Detonation and Its Hydraulic Analogy", 4thSympCombstn (1953), pp 471-79 4) D.R. White, JFluidMech **2**, 513-14 (1957) (On the existence of higher

than normal detonation pressures)
 5) Dunkle's Syllabus (1957-1958), 292 (A brief description of Oppenheim's work on predetonation) 6) Cook (1958), 83 & 87-9 7) Ya.K. Troshin, "The Generalized Hugoniot Adiabatic Curve", 7th Symp Combustn (1959), pp 789-98 8) V.A. Popov, "On the Pre-Detonation Period of Flame Propagation", Ibid, 799-806 8a) T.V. Bazhenova & I. Soloukhin, "Gas Ignition Behind the Shock Wave", Ibid, 866-75 9) R.F. Chaiken, "Comments on Hypervelocity Wave Phenomena in Condensed Explosives", 3rd ONRSymp Deton (1960), 304-07 10) Dunkle's Syllabus (1960-1961), pp 17c & 23e 11) K.I. Shchelkin & Ya.K. Troshin, "Gazodinamika Goreniya" (Gas Dynamics of Combustion), Izdat Akad Nauk, Moscow (1963), 255 pp 11a) Ibid, "Gasdynamics of Combustion (2)", Mono Book Corp Baltimore, Md. (1965) (in English) 12) C.G. Dunkle; private communication, Jan 1968

SECTION 8

Detonation (and Explosion, Pressures of and Their Measurements.

One must distinguish between pressure of gases produced on detonation and total pressure developed on detonation. The latter can be produced even by expls evolving no gases as, for example, the mixt of powdered aluminum and potassium chlorate. It detonates according to the equation:

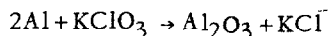

Accdg to the late W.H. Rinkenbach (Ref 51): "Pressure is described as a 'thermodynamic coordinate', and this is correct. Basically, it is an increase in the number of molecular or atomic kinetic impacts per unit area of a container. This may be caused by increase in temperature or by increase in the number of molecules or atoms per unit volume

"Detonation pressure" might be taken to mean (1) the pressure in the shock zone ahead of the reaction zone, (2) pressure in the front of the reaction zone or (3) the pressure effect on the first layer of the solid confining medium

(1) is the C-J (Chapman-Jouguet) pressure and needs no explanation. The high

C-J values of explosives are understandable when there are considered the high temperatures developed without significant change in volume

(2) is not uniform thruout the reaction zone, which has the same velocity as the shock zone preceding it. The average pressure in the reaction zone is less than that in the shock zone. When the end of the column of explosive is reached, and there is no more shock zone in the explosive, it is the impact of this reaction zone on the confining medium that represents the "shock effect" of the explosive. Another aspect of this is that it is the "shock effect" of the reaction zone that results in the continued propagation of explosion

(3) involves a change in the elastic limit of the material upon which the advancing detonation zone impinges. It is this elastic limit of the surrounding medium that determines to what extent pressure can be built up in it before rupture takes place. This accounts for the great difference between the initial layer pressures found for air and metal with the same explosive. So (3) will be an inverse expression of the "shock effect" (brisance) of the explosive rather than its work capacity"

Dunkle (Ref 40) points out that *total pressure* is also known as *stagnation pressure* and is equal to the sum of *static pressure* and *dynamic pressure*. Both of these are exerted by gases. More detailed explanation is given in Ref 40, p 32. He also states that in the reaction between Al & K chlorate, mentioned above, the products formed at the temperature of explosion are gaseous KCl, AlO, Al₂O and oxygen. The Al₂O₃ does not form until the products cool

In the letter of Jan 22, 1964 (Ref 50), Dunkle pointed out that equating *detonation pressure* with *detonation shock* (as has been done by some investigators) is wrong because pressure is a thermodynamic coordinate, while shock is a phenomenon. We might speak of *detonation shock pressure*, but this would not make it clear whether we mean the "detonation (Chapman-Jouguet or C-J) pressure", or the "pressure in the shock front" of the shock wave set

up in a surrounding inert medium by the detonation. There is a tremendous difference. For instance the initial shock overpressure in air at the edge of a detonation spherical charge of 50/50-Pentolite of density 1.65 g/cc is only 12030 psi or 818 atm (as detd by Goodman of BRL in 1960), whereas the C-J pressure in this explosive is 243000 bars or 240000 atm. If the inert medium is metal, on the other hand, the initial shock pressure in it can be higher than the detonation pressure of the explosive.

Accdg to Cook (Ref 41, pp 32-5 & 279), the *detonation pressure* (p_2) cannot be measured directly (at least in condensed explosives), owing to its transient nature and its exceedingly high magnitudes. This pressure can, however, be accurately defined by the following hydrodynamic equation:

$$P_2 = \rho_1 DW + p_1$$

where (ρ_1) - original explosive density, (D) - detonation velocity, (W) - particle velocity, and (p_1) - initial pressure, which is usually negligible compared with (p_2). Since (ρ_1) and (D) may be accurately measured, any method for measuring (W) (such as of Gehring & Dewey described in Ref 34, in Ref 40, p 302 and in Ref 41, p 32) would also be a measure of (p_2).

Furthermore, since (W) & (D) are related thru the density (ρ_1) in the original explosive, and the density (ρ_2) at the *Chapman-Jouguet plane*, by the equation:

$$W = (1 - \rho_1 / \rho_2) D$$

it would be sufficient to determine (ρ_2) and then calculate (W) and (p_2). For detn of (p_2), Schall (Ref 23a) measured the density behind the wave front in "Pentolite" from densiometric traces of flash radiographs. His measurements gave (ρ_2), which, when inserted in the above equations, gave a (p_2) about 30% lower than was detd by later measurements. Kistia-kowsky (Ref 23b) has used time-resolved density measurements from X-ray absorption to deduce pressure characteristics thru the reaction zone to the Chapman-Jouguet plane and back into the products of detonation in gaseous explosives (Ref 41, p 32)

In our definition of *brisance*, given in Vol 2 of Encycl, p B266, we included the remark of Cook that the property formerly attributed to brisance is now attributed to *detonation pressure*. We gave his equation for (p_2), but did not list the following more accurate equation:

$$p_2^* = 0.00987 \rho_1 D^{*2} \left(0.380 - \frac{1270 \rho_1}{D^* \rho_c} \right)$$

where asterisk (*) is used to designate ideal quantities, (ρ_1) - loading density in g/cc, (ρ_c) - crystal density; and (D^*) - ideal detonation velocity

The above equation for Chapman-Jouguet pressure may be extended to non-ideal detonation by replacing the factor 1270 by 1270D/D* (Ref 38, p 35)

Dunkle (Ref 53) used Cook's equation for calculating Chapman-Jouguet pressures for a number of explosives. He listed these pressures in a 7-page table, among other Chapman-Jouguet parameters. An abbreviated version of this table is given in Section 2 under "Detonation, Chapman-Jouguet Parameters in"

In the letter of Jan 15, 1964 (Ref 50), Dunkle stated that *detonation pressure* can be expressed by the formula:

$$P = \rho D^2 (\gamma + 1)$$

where (ρ) is loading density, (D) - detonation velocity, and (γ) the polytropic exponent of the detonation products [See under Detonation, Equations of State, item (w) Polytropic Equation of State]

Since "brisance" has been characterized also by the product of available energy and the square of the detonation velocity, it seems that detonation pressure can serve as a measure of brisance (Compare with statement of Schmidt as given by Roth in Ref 39, p 162)

Definition of so-called *peak-pressure* is given in Vol 2 of Encycl, p B181 under BLAST EFFECTS IN AIR, EARTH AND WATER. More detailed description is given by Dunkle under the title "Peak Pressure and Impulse" (Ref 40, p 363-69) and by Cook (Ref 41) in Chapter 13, "Shock Waves in Gaseous and Condensed Media". There (on pp 326-27) is discussed "peak-pressure

of air blast wave" and (on p 328) "peak pressure of underwater wave in TNT, Tetryl and Pentolite". Cook also discussed "peak pressure in detonation wave of gases" and presented in Fig 5.4, p 96 Total impulse and peak-pressure measurements of detonation head in $2\text{H}_2\text{O}-\text{O}_2$ at 12.5 psia

Definition of *spike pressure* and probability of its existence are briefly discussed in this Vol under Detonation (and Explosion) in Condensed-Phase Explosives". The so-called *spike theory* is discussed under "Detonation, Spike Theory in". A more detailed description is given by Cook (Ref 41, pp 69-87)

In the book of Zel'dovich & Kompaneets (Ref 45a), the following subjects related to detonation pressure are discussed: p 12-13 (Shock compression and isentropic compression); 14 (Static pressure); 27 (Pressure in weak shock waves); 31 (Pressure in shock wave of an ideal gas); 97-8 (Formation of an overcompressed detonation wave on forcing the detonation in a gas to pass from a large pipe to a narrow one); 216 (Investigation at the Chemical Physics Institute of the Academy of Sciences has shown for large charge diameters of condensed expls, pressures of the order of $3 \cdot 10^5 \text{ kg/cm}^2$ arise in the detonation wave); 223 [Calculation of pressure from Van der Waals equation of state: $p = RT/(\nu - b)$]; 224 (Assumption of Landau & Stanyukovich that in the explosion products of Landau & Stanyukovich for a density in excess of 1 g/cm^2 the main part of pressure is of elastic origin and depends only on the density of explosion products, but not on the temp); 217 (Effect of pressure on thermal dissociation is discussed. In the case of condensed expls the pressure indirectly affects the molecular separation and alters the rate of chemical reaction. Experiments of Yu.N. Riabinin have shown that the reaction rate was diminished at a high pressure, up to $5 \cdot 10^5 \text{ kg/cm}^2$)

The following references listed after Experimental Determination of Pressure Developed on Detonation (or Explosion) deal with theoretical aspects of pressures:

2, 9, 9a, 10, 11, 11a, 12, 12a, 13, 14, 15, 16, 17, 17a, 18, 19, 21, 23a, 23b, 24, 26, 30, 31, 32, 33, 35, 35a, 37, 38, 38a, 40, 41, 41b, 44, 45, 46, 48, 49, 50, 51, 52 & 56

Experimental Determination of Pressures Developed on Detonation (or Explosion).

A brief description of tests which can be used for approx determination of pressure developed on detonation or explosion is given in Vol 1 of Encycl (Ref 47), p VIII (Bichel Bomb); p IX (Closed Vessel Test); p X (Compression Tests); p XVI (Hopkinson Pressure Bar); and p XX (Pressure of Gases Developed on Detonation)

More complete descriptions of some of these tests are given in Vol 3 (Ref 55, pp C330-L to C345-R, under Closed Bomb (Vessel) and Instruments for Measuring Pressures Developed by Explosives and Propellants. Included are Bichel Pressure Gage, pp C331-C332; Closed Bombs of CSE, p C332; Bomb of Burlot-Malsallez, p C332; Closed Bomb of Sarrau-Vieille, p 333; British Service Closed Vessels, pp C333 & C334; American Closed Vessels (or Bombs), pp C334-C336; American External Pressure Gage T14, p C336; British Service Crusher Gage, p C336; US Internal Crusher Gage M11, p C337; Spring (or Mechanical) Gages, including Petavel Manometer, known also as Optical Spring Gage, pp C337 & C338; ARE (Armament Research Establishment) Spring Gauges, p C338; Piezoelectric Gages, including British Piezoelectric Gauge (Quartz), p C339; British Piezoelectric Gauge (Tormaline), p C340; Strain Gages, including British Strain Gauge, p 341 and US Strain Resistance Wire Transducer Pressure Gage, Model C-AN, pp C341 & C342. Included are also Baldwin SR-4 Standard Fluid Pressure Cell, p C342 and Kistler Quartz Pressure Transducer, p C342. An Adapter for Some Kistler Pressure Transducers is described on pp C342 & C343

Mason et al (Ref 22) determined pressure of deton for PETN & Tetryl charges, which were used for luminosity tests. The investigation was conducted by recording the change of electrical resistance of

tungsten wire grids placed in the expl chges. Although the deton pressures were sufficiently high to change the electrical resistance by a measurable amt, the interpretation of results was limited by the stability and strength of the metallic structures at these extreme values and also by secondary effects due to the high temps associated with the high pressures in the deton zone. Evidence of conduction effects that occur during the deton interval appears in the Fig A reproduced on pD487

This sweep trace shows the change in electrical resistance of a tungsten-wire grid as detected by a resistance-bridge network and a two-stage high frequency amplifier connected to the vertical plates of a cathode-ray tube. The grid was cemented betw expl pellets of PETN at a d 1.45 g/cc. This grid element was broken in assembly and the initial position of the sweep indicated a very high value of resistance for the pressure element in the bridge circuit. The rapid deflections that occur in the trace are due to conduction effects thru the tungsten-grid element as the deton zone passes. The max deflection corresponds to a resistance value of less than 10 ohms; the total duration of this conduction interval is less than 1.5 microsecs. Other deton pressure measurements were conducted with intact tungsten-wire grids attached directly to the expl chge and also with other arrangements. Their luminosity curves are given in Figs 3a & 3b of the report. No values of recorded pressures were found in the above report

V.M. Boyle et al (Ref 53a, pp 855-61) determined the pressures developed during shock initiation of 60/40-Comp B with 2% wax incorporated using an indirect method, since direct measurements are not feasible at present. The experiment consisted of dynamic observations of the shock wave in an inert material (Plexiglas) placed on the edge of Comp B. The velocity of a chemically supported shock in the explosive and the average shock velocity in the Plexiglas were measured with a rotating-mirror camera. Effects of the Plexiglas thickness were determined and the shock

vels in the Plexiglas were corrected to zero thickness. As the chemically supported shock propagates within the explosive, the pressure builds up in a manner analogous to the wave velocity. The shock velocity (U) (vel of the incident wave in the expl measured at the explosive-Plexiglas interface, cm/sec) is shown to be related to the particle velocity (u_1) behind the incident wave by the linear relation:

$$U_1 = 2.88 \times 10^5 + 1.60u, \text{ cm/sec}$$

As the Hugoniot data are known from previous investigators, the pressure in the Plexiglas can be calcd directly from the shock velocity measurements as shown on p 856 of paper

The pressure at the shock front (p_1) (which is the same as the pressure behind the incident wave in the explosive, expressed in dynes/cm²) was calculated from the equation:

$$P_1 = \rho_1 U_1 u_1$$

where ρ_1 is density of expl in g/cc

The pressure obtd from equation in dynes/cm² was divided by 10^9 to express it in kbars. It varied for Comp B from 62 to 173 kbar. A single point at 388 kbar was obtd from shock-velocity measurements on a thin aluminum foil placed in contact with the explosive. This point corresponds to the vonNeumann "spike pressure"

For more detailed description of particle-velocity measurements, see "Detonation, Particle Velocity in; and Its Determination"

Andreev & Belyaev (Ref 44, pp 247-49) describe a method of *experimental determination of pressure of detonation*, using the arrangement shown in Fig B, Here 1 is charge of an explosive enclosed in a metallic container, and 2 is a metallic (usually aluminum) plate, 1-2 mm thick, firmly inserted as a cover at the end of cartridge opposite detonator, 3. On initiation of charge, a shock wave will spread to plate 2 and, when the wave reaches the outer surface of the plate, it will start to move with initial velocity V_H (here H is nachal'naya, which means initial). After determining this velocity experimentally, the

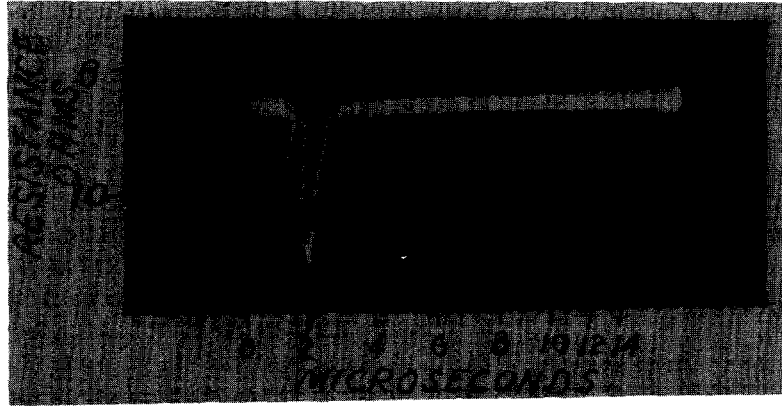

Fig A

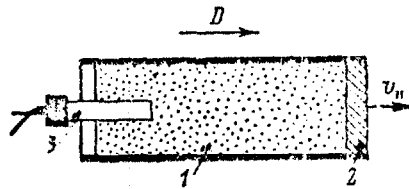

Fig B
Experimental Arrangement
for Determination
of Pressure of Detonation

value of ω_M , which is velocity of material behind shock wave in metal, is calculated from the expression:

$$\omega_M = V_H/2$$

Value of D_M = velocity of shock wave in the metal, can be calculated using the equation of dynamic adiabat of metal, or it can be determined experimentally

If initial density of metal ρ_{O_M} is known, the pressure of shock wave in metal is:

$$P_M = \rho_{O_M} D_M \omega_M$$

In the case of a freely spreading detonation wave (in a cartridge not closed with plate 2), P_M is not equal to P_D , which is the pressure of detonation at the *Chapman-Jouguet Point* (ie in the plane of completion of chemical reaction), but can be calculated. If detonation velocity, D , and its density, ρ_O , are known, P_D may be calcd

from the approximate equation:

$$P_D = \frac{P_M}{2} \left(1 + \frac{\rho_O D}{\rho_{O_M} D_M} \right)$$

Following Table gives comparison between pressures, P_D (in atmospheres) at the C-J point determined experimentally by this method with those calculated by formula: $P_2 = 1/4 \rho_O D^2$

Table

| Explosive | Density, g/cc | Experimental | Calculated |
|-----------|---------------|---------------------|---------------------|
| RDX | 1.785 | 388.10 ³ | 346.10 ³ |
| TNT | 1.64 | 189.10 ³ | 200.10 ³ |

Accdg to Dunkle (Ref 56), *free-surface velocity method for determination of detonation pressure*, developed by R.W. Goranson, was probably first described in then conf Los Alamos Rept No 487 (1955) (listed here as Ref 35a). The method seems to be de-

classified now since it was discussed at the 10thSympCombstn (Ref 53a, p 863-67) by B.G. Craig in the paper: "Measurements of the Detonation-Front Structure in Condensed-Phase Explosives". The method is mentioned by C. Fauquignon et al in the 4thONRSympDeton (Ref 54, pp 39-46) in the paper: "Detonation of a Cylindrical Charge - Study of the Flow of Burned Gases". In this paper are listed the following five refs to the "free-surface velocity method":

- a) R.E. Duff & E. Houston, *JChemPhys* **23**, 1268 (1955)
- b) W.E. Deal, *JChemPhys* **27**, 796 (1957)
- c) A.N. Dremin & P.F. Pokhil, *DoklAkadN* **128**, 889 (1959)
- d) M.L. Wilkins et al, UCRL Report **7797**(1964)
- e) B.G. Craig, 10thSympCombstn (1965) - See above

Briefly, the method of Craig consists of measuring the detonation-wave structures at the axis of long cylindrical chges of expls by using them to drive plates and measuring the initial free-surface velocity of the driven plate as a function of plate thickness. The plate velocities are related to the pressure in the expl at a distance back in the expl approx proportional to the plate thickness. The free-surface velocities are measured using a smear camera technique. Accurate measurements (within 1%) can be made with this technique because the image motion is very small compared to the radius of curvature of the shock waves. The experimental conditions and the quality of expl, plates, boosters & other conditions must be carefully controlled in order to obtn highly reproducible data

Another method for determination of detonation pressure is by the "measurements of the velocity of shock wave set-up by normal impact of the detonation front on the explosive/water interface". It was mentioned by Fauquignon in the same paper as above, but not described. He gave the following refs where the method is described:

- a) C. Fauquignon, *CR* **251**, 38 (1960) and
- b) M.A. Cook et al, *JApplPhys* **33**, 3413 (1962)

Briefly, the method consists of application of the "aquarium technique" for mea-

suring the initial vel of the shock (and pressure) in water transmitted directly from the detonating expl. The charges made from granular or loose material were vibrator-packed in thin walled (0.16 cm thick) cardboard tubes waterproofed with a 3-mil thick sheet of Polyethylene. The expls used were pelleted. TNT, granular TNT, cast 65/35 Baratol, cast 50/50 Amatol, granular 50/50-AN/TNT, granular RDX, granular RDX-salt, HBX-1 and a classified expl. Cast chges were detonated with bore end immersed in aquarium. The assembly was aligned so that streak camera observations were made along the chge axis, the height and tilt of the assembly being such that the bottom face of the chge was coincident with (and parallel) to the optical axis of the camera. The streak camera viewed the chge upward thru a periscope in which the line of sight was reflected to a horizontal direction by a front surface mirror. Measurements of the peak pressures by the aquarium technique were found to be the C-J or detonation pressures of the thermohydrodynamic theory

Among the references listed below, the following deal more or less with experimental determinations of pressures: 1, 3, 4, 5, 6, 7, 7a, 8, 9, 9a, 14, 15, 17, 19, 20, 21, 22, 23, 25, 28, 29, 34, 39, 42, 43, 44, 53, 54, 55 & 56

The refs which follow include descriptions of pressures determined by calculation and by experimental procedures
Refs: 1) E. Sarrau & P. Vieille, *MP* **1**, 356 (1882) (Étude sur l'emploi des manomètres à écrasement pour la mesure des pressions développées par les substances explosifs) 2) E. Sarrau, "Théorie des Explosifs", Gauthier-Villars, Paris (1895), 24-7 (Formule de la pression maximum); 27-44 (La mesure des hautes pressions); 44-9 (Formule des pressions) 3) C.E. Bichel, "New Methods of Testing Explosives", Griffin & Co, London (1905), 15-25 (Bichel pressure gage) 4) B. Hopkinson, *PhilTrans* **213A**, 437 (1914) (Pressure bar) 5) Marshall **2** (1917), 444-53 & 495-501 (Pressure measurements)

- 6) C.E. Munroe & J.E. Tiffany, "Physical Testing of Explosives", USBurMinesBull **346**(1931), 84-95 (Determination of pressure developed by expls with Bichel Pressure Gage); 95-99 (Crawshaw-Jones apparatus)
- 7) Marshall **3**(1932), 155-57 (Pressure measurements) 7a) C. Campbell et al, PrRoySoc **137A**, 380(1932) (Measurement of pressure developed in explosion waves)
- 8) Vennin, Burlot & Lécorché(1932), 70-82 (Mesure de la pression) 9) Stettbacher (1933), 69-78 (Explosionsdruck); 91 (Die Messung des Gasdruck in der Bombe)
- 9a) Beyling & Drekopf (1936), 49-58 (Der Explosionsdruck) 9b) E. Czerlinsky, ZTechnPhysik **21**, 75(1940) (Druck- und Flammengeschwindigkeitsmessungen bei Detonationen von Athyläther-Luft Mischungen)
- 10) H. Muraour & M. Basset, Chim & Ind (Paris) **45**, Suppl to No 3, pp 218-24 (1941) & CA **37**, 4572(1943) (Investigation of influence of high pressure on the progress of decomposition of explosives, particularly the initiating explosives)
- 11) F.W. Brown, "Theoretical Calculations of ExplosivesII. Explosion Pressures", USBurMinesTechPaper **643**, 1942
- 11a) Ya.B. Zel'dovich ZhEksper i TeoretFiz **12**, 389(1942) (Pressure and velocity distribution in the detonation products of an explosion, specifically for spherical propagation of the detonation wave)
- 12) J.G. Kirkwood et al, "The Pressure Wave Produced by an Underwater Explosion", OSRD Repts **588**, **670** & **813**(1942) 12a) V. A. Tsukerman, DoklAkadN **40**, 467(1943) (Pressure of detonation)
- 13) S.R. Brinkley & E.B. Wilson, Jr, "Calculation of Detonation Pressures of Several Explosives", OSRD **1231**(1943) 14) Vivas, Feigenspan & Ladreda, Vol 4 (1944), 20-29 (Presión de los gases producidos por la explosión en función de la densidad de carga); 85-6 (Manómetros); 98-104 (Medidor de presión de la casa Carbonit, known in US as Bichel Bomb)
- 15) Pérez Ara (1945), 48-53 (Presión de explosion); 73-90 [Medición de la presión de los gases, which includes: manómetro de Rodman, manómetro de aplastamiento (crusher gage), crusher de Noble, rifle medidor de Strange, manómetro registrador de Bichel, manómetro crusher registrador de Vieille et Sarrau, manómetro de Petavel, los manómetros piezoeléctricos and piezoindicador manométrico de "Zeiss-Icon"]
- 16) ERL (Explosives Research Laboratory), Bruce-ton, Pa, "The Estimation of Detonation Pressure from the Shock Wave Velocity in Lead", OSRD **5612**(1945)
- 17) H. Muraour, "Poudres et Explosifs", Presses Universitaires de France, Paris (1947), 73 (Détermination des pressions en vase close); 83-90 (Mesure de la pression; a brief description of la bombe type Vieille, bombe Krupp, crusher et quartz piezoélectrique)
- 17a) M.A. Cook, JChemPhys **15**, 518-24(1947) (Some calcd values of Chapman-Jouguet pressures and temperatures)
- 18) Yu.N. Riabinin (or Ryabinin), DoklAkadN **58**, 245-48(1947); CA **44**, 7539 (1950) (Influence of pressure on the rate of thermal decompn of expls) (Abbreviated translation by B.T. Fedoroff is available in PicArns Library as U 6383)
- 19) Stettbacher (1948), pp 15, 26 & 139 (Detonationsdruck)
- 20) R.M. Davies, PhilTrans **240A**, 375-457 (1948) (A critical study of the Hopkinson pressure bar method)
- 21) Caprio, Vol 1 (1948), 32 (Calcolo della presione di esplosione in vaso chiuso); 44-6 (Misura della pressione di esplosione)
- 22) C.M. Mason et al, "The Physics and Chemistry of Explosive Phenomena", USBurMines-ProgressRept Oct-Dec 1949, Contract NA-onr-29-48, Project NR 053 047
- 22a) J.C. Clark, JApplPhys **20**, 363-75 (1949) (Flash radiography applied to Ordnance problems)
- 23) R.M. Davies et al, PrRoySoc **204A**, 17-19 (1950) (Pressure bar measurements in detonating gases using the electrical modification of the Hopkinson pressure-bar)
- 23a) R. Schall, ZAngewPhysik **2**, 252 (1950); Ibid **3**, 41 (1951) (Pressure of detonation)
- 23b) G.B. Kistiakowsky, JChemPhys **19**, 1611 (1951) (Calcn of detonation pressure)
- 24) Taylor (1952), 55-58 (Theoretical pressure of explosion); 67, 81-83, 84-87, 89, 93-95, 102-09 & 115-33 (Detonation pressure; calcd values and theoretical expressions); 174-78 (Reaction rate determined by detonation pressure)

- 25) P.Z. Kalavski, "A High-Speed Recording System Using the Velocity Method to Determine the Peak Pressure Produced in Air by Explosives", USNOL, NavOrd-Rept **2167** (1952) 25a) E.W. Bridgman, "The Physics of High Pressure", G. Bell, London (1952) 26) Belgrano (1952), p 5 (Pressione specifica) 27) H.D. Mallory, "The Measurement of Detonation Pressure in Explosives", NavOrdRept **1883** (1953) 27a) H.D. Mallory, "The Measurement of Detonation Pressure in Cast TNT", NavOrdRept **2913** (1953) 28) W.C. Holton, "The Detonation Pressures in Explosives as Measured by Transmitted Shocks in Water", NAVORD **3968**, USNavalOrdLab, White Oak, Md (1954) 29) M. Sultanoff & G.R. McVey, "Shock Pressure at and Close to the Surface of Spherical Pentolite Charges Inferred from Optical Measurements", BRL Rept **917** (1954) 30) T. Sakurai, JIndExplJapan **15**, 8-11 (1954) & CA **49**, 11284 (1955) (Exptl determination of pressure in deton wave) 31) W.E. Deal, Jr, "The Measurement of Chapman-Jouguet Pressures for Explosives", p 209 in the 2ndONRSympDeton (1955) 31) R.E. Duff & E. Houston, "Measurement of the Chapman-Jouguet Pressure and Reaction Zone Length in a Detonating High Explosive", p 225 in the 2ndONRSympDeton (1955) and in JChemPhys **23**, 1268-73 (55) 32) H.D. Mallory & S.J. Jacobs, "The Measurement of Detonation Pressure in Cast TNT", p 240 in the 2ndONRSympDeton (1955) 34) J.W. Gehring Jr & J. Dewey, "An Experimental Determination of Detonation Pressure in Two Solid High Explosives", BRL Rept **935** (1955) 35) W. Noddack & E. Grosch, Explosivst **1955**, 69-78 and Picatinny Arsenal Translation **No 9** (1956) by Dr G. Loehr, "Measurement of the Detonation Pressures of Initiator-Type Explosives" 35a) R.W. Goranson, Classified Los Alamos Rept No **487** (1955). See Ref 31 35b) R.E. Duff & E. Houston, "Measurement of Chapman-Jouguet Pressure and Reaction Length in the Detonation of High Explosives", JChemPhys **23** (7), 1268-73 (1955) 36) G.R. Pickett, "Seismic Wave Propagation and Pressure Measurements Near Explosions", Quarterly Rept of the Colorado School of Mines **50**, 1-78 (Oct 1955) 37) A.R. Ubbelohde & J. Copp, "Detonation Processes in Gases, Liquids and Solids", pp 577-609 of the book "Combustion Processes", edited by B. Lewis et al, PrincetonUnivPress, Princeton, NJ (1956), 84 refs 38) W.E. Deal, JChemPhys **27**, 796-800 (1957) (Measurement of Chapman-Jouguet pressure of expls) 38a) D.R. White, JFluidMech **2**, 513-14 (1957) (On the existence of higher than normal deton pressures) 39) J.F. Roth, Explosivst **1957**, 161-76 (Ballistic Methods for Measuring Explosive Power and Detonation Shock) 40) Dunkle's Syllabus, (1957-1958), pp 1-3 (Measurement of detonation pressure); 178-81 (Calc'n of detonation pressures and densities); 298-304 (Measurement of detonation pressure); 363-69 (Peak pressure-distance relationships curves) 41) Cook (1958), 32-35 (Measurement of deton pressure); 265-68 (Maximum available work and peak blast pressure) 41a) I. Ginsburgh, JAppl-Phys **29**, 1381-82 (1958) (Abnormal pressures in a shock tube) 41b) D. Price, ChemRevs **59**, 801-25 (1959) (Substituted in her discussions the term "detonation pressure" for "brisance" and "detonation energy" for "power") 42) Baum, Stanyukovich & Shekhter (1959), 139-43 (Bichel bomb for detn of pressure) 43) Bandurin & Rukin (1959), 69-74 (Pressure of gases formed on expln in a closed vessel) 43a) A.B. Amster & R.L. Beauregard, "Pressure Sensing Probes for Detecting Shock Waves", RevSciInstrs **30**, 942 (1959) 44) Andreev & Belyaev (1960), 245-47 (Determination of pressure developed on deton of condensed expls; for Tetryl of density 1.6 the pressure was ca 200000 kg/cm); 247-49 (Schematic view of apparatus for exptl detn of deton pressure); 432-44 (Calc'n of pressure of expln and burning); 442-43 (Detn of pressure by means of manometric bomb of Sarrau & Vieille) 45) W.B. Garn, JChemPhys **32**, 653-55 (1960) (Detonation pressure of liquid TNT) 45a) Ya.B. Zel'dovich & A.S. Kompaneets, "Theory

- of Detonation", Academic Press, NY (1960) (translated from Russian edition of 1955), pp - See in the text 45b) C. Fauquignon, CR **251**, 38-40 (1960) (Balistique Intérieure, Evaluation de la Pression du Choc Initiateur d'une Détonation) 45c) J. Berger, Ann de Phys **5**[13], 1144-76 & CA **55**, 10890 (1961) (Determination of detonation characteristics of solid explosives) 45d) J.O. Erkman, "Pressure Profile for an Explosively Induced Oblique Shock in Water", Poulter Labs Internal Rept **007-60** (1960) 46) G.E. Hauver, "Pressure Profiles in Detonating Solid Explosives", 3rdONRSympDeton (1960), pp 241-52 46a) M.A. Cook et al, "Measurements of Detonation, Shock, and Impact Pressures", Ibid, pp 357-85 46b) W.E. Deal, "Low Pressure Points on the Isentropes of Several High Explosives", Ibid, pp 386-95 46c) I. Jaffe et al, "Determination of the Shock Pressure Required to Initiate Detonation of an Acceptor in the Shock Sensitivity Test", Ibid, pp 584-605 46d) M.A. Cook et al, TrFaradSoc **56**, Pt 7, 1028-38 (1960) (Determination of critical shock pressures for initiation in certain military explosives) 47) PATR **2700**, Vol 1 (1960), p VIII (Bichel Bomb); XVI (Hopkinson Pressure Bar); XX (Pressure gages) 48) Dunkle's Syllabus (1960-1961), p 11a (Total or stagnation pressure in deton of gases); 17a (Calc'n of pressure of deton in solid expls by the method of A. Clark) 48a) F.P. Bundy et al, Eds, "Progress in Very High Pressure Research", Wiley, NY(1961) 49) PATR **2700**, Vol 2(1962), p B182, Table (Peak pressure in air blast for some US military expls) 49a) I. Jaffe et al, AmRocketSocJ **32**, 22-5 (1962) & CA **56**, 11872 (1962) (Detn of shock pressure required to initiate detonator of an acceptor in the shock sensitivity test) 49b) S. Paterson & P. Lamb, JPhotSc **9**, 363-72 (1961) & CA **56**, 6230 (1962) (Photographic measurement of detonation pressure in a granular explosive) 49c) M.A. Cook et al, JApplPhys **33**(12), 3413-21 (1962) (Measurements of detonation pressure) 49d) R.S. Bradley, Ed, "High Pressure Physics and Chemistry", Academic Press, NY, Vols 1 & 2(1963) 49e) A.A. Giardini & E.C. Lloyd, "High Pressure Measurement", Butterworths, London (1963) 49f) D.D. Keogh, "Pressure Transducer for Measuring Shock Wave Profiles", Stanford Research Inst Project No **GPU-3713**, Final Rept (1963) 50) C.G. Dunkle; private communication Jan 15 & 22 (1964) 51) W.H. Rinckenbach; private communication, Feb 1964 52) N.L. Colborn, "Chapman-Jouguet Pressures of Several Pure and Mixed Explosives", US NOL, White Oak, Silver Spring, Md, **TR 64-58** (1964) 53) C.G. Dunkle, "Measurement of Detonation Pressure and Temperature in High Explosives", AppliedPhysicsLaboratory Rept BBW/CGD/M-13 (1965), Johns Hopkins Univ, Silver Spring, Md 53a) TenthSympCombstn (1965). Titles of papers and pages are indicated in the text 53b) L.D. Sadwin & N.M. Junk, "Measurement of Lateral Pressure Generated from Cylindrical Explosive Charges", USBurMines, Rept of Investigation **RI 6701** (1965) 54) FourthONRSympDeton (1965). Titles of papers and pages are indicated in the text 55) PATR **2700**, Vol 3 (1966), pp C492 to C494 (Compression tests) 55a) EleventhSympCombstn (1967) - No papers on detonation pressure 55b) C. Gueraud et al, CR **264B**(1), 5-8 (1967) & CA **66**, 8180-R (1967) (Measurement of detonation pressure variation in gas mixtures) 56) C.G. Dunkle, private communication, Jan 1968 57) TwelfthSympCombstn (1968) (Publ 1969) - No papers on detonation pressure

Detonation Pressure-Charge Density Relationship and Temperature of Detonation-Charge Density Relationship.

Caldirola (Ref 1) calculated, using some equations of "hydrothermodynamic theory of detonation", the following pressure & temperature values for PETN, Tetryl, Picric Acid and TNT at different densities

Table 1

| Explosive | Density of chge, g/cm ³ | Pressure p, kg/cm ² | Temp, T, °K |
|-----------|------------------------------------|--------------------------------|-------------|
| PETN | 0.80 | 65000 | 5050 |
| | 1.00 | 95300 | 5320 |
| | 1.20 | 140500 | 5720 |
| | 1.40 | 195500 | 6170 |
| Tetryl | 1.60 | 262800 | 6670 |
| | 1.00 | 91800 | 4400 |
| | 1.28 | 160400 | 4740 |
| | 1.45 | 218100 | 4980 |
| PA | 1.54 | 242500 | 5100 |
| | 1.61 | 259100 | 5140 |
| | 1.03 | 83000 | 3880 |
| | 1.23 | 120700 | 4070 |
| TNT | 1.39 | 164600 | 4280 |
| | 1.63 | 239400 | 4660 |
| | 1.00 | 68700 | 3210 |
| | 1.29 | 132800 | 3610 |
| | 1.46 | 178000 | 3860 |
| | 1.59 | 216200 | 4020 |

Mason & Gibson (Ref 2) conducted at USBurMines a series of tests to detn relationship betw density and temp of deton. Their results, which are considered tentative, are represented here in Table 2

Table 2

| Explosive | Density, g/cm ³ | Temp, °K |
|-----------|----------------------------|----------|
| Tetryl | 0.95 | 4800 |
| | 1.5 | 5750 |
| PETN | 1.0 | 5783 |
| | 1.48 | 6900 |
| TNT | 0.70 | No detn |
| | 1.5 | 4417 |

The graphical representation (See Fig C) showed that the values obtd at the BurMines, ● are higher than those obtd by Caldirola, ✕

In Ref 3 detns by radiation method of temps of deton in relation to densities were described. The results were given graphically in Figs 1 & 2 of the rept, where the curves represented the least squares line (linear relationship assumed) thru the points each of which represented a single determination. The Figs are not given here, but instead the following approximate values derived from curves are listed in Table 3

Table 3

| Explosive | Density, g/cc | Temp, °K |
|-----------|---------------|----------|
| PETN | 1.0 | 5125 |
| | 1.2 | 5700 |
| | 1.5 | 6550 |
| RDX | 1.15 | 5500 |
| | 1.3 | 5550 |
| | 1.55 | 5700 |
| Tetryl | 0.95 | 4700 |
| | 1.2 | 5100 |
| | 1.55 | 5750 |
| TNT | 0.7 | 3650 |
| | 1.15 | 4350 |
| | 1.5 | 4750 |

Gibson et al (Ref 4) gave graphical representation of the temp-density relationship for four expls and also tabulated the values. We averaged their values for temps and present them here in Table 4

Table 4

| Explosive | Density, g/cc | Temp of Deton, °K |
|-----------|---------------|-------------------|
| EDNA | 0.96 | 5630 |
| | 1.25 | 5365 |
| | 1.28 | 5450 |
| | 1.46 | 5390 |
| PETN | 0.90 | 5275 |
| | 1.37 | 5620 |
| | 1.56 | 5825 |
| RDX | 1.13 | 5610 |
| | 1.41 | 5470 |
| | 1.60 | 5640 |
| Tetryl | 0.92 | 4610 |
| | 1.22 | 4670 |
| | 1.62 | 5275 |
| | | |

Refs: 1) P. Caldirola 14, 740 (1946) (Tables giving relationships between densities - detonation pressures, temp of detonation and velocities of deton for some expls) 2) C.M. Mason & F.C. Gibson, "Detonation and Explosives Phenomena", USBurMines-ProgressReport No 7, Jan-March 1955, Army Project 599-01-004, Ordn Proj TB2-0001 3) Ibid, ProgrRept No 8, April-June 1955 4) F.C. Gibson et al, JAppl-Phys 29, 630 (1957) (Density-temperature of detonation relationship for some expls)

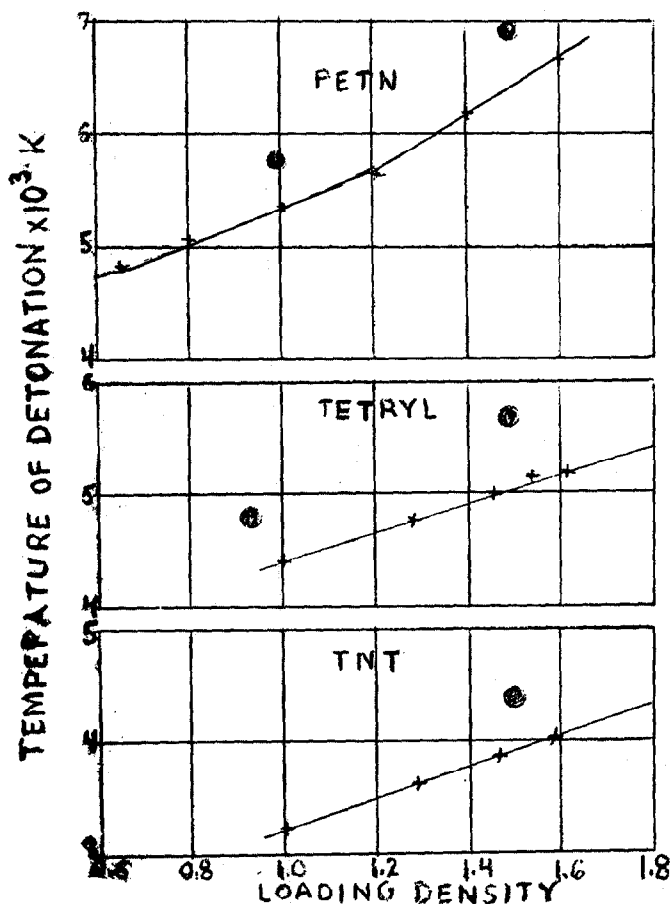

Fig C

5) Cook (1958) - not found 6) Dunkle's Syllabus (1957-1958), pp 178-81 (Detonation pressure and densities)
 Note: Accordg to C.G. Dunkle, "Unlike detonation pressure, detonation temperature shows no definite trend with density, and the agreement among the values of it reported by different investigators is poorer"

He also suggested addg the following references:

7) F.C. Gibson et al, "Use of an Electro-Optical Method to Determine Detonation Temperatures in High Explosives", JAppl-Phys **29**, 628-32 (1958) 8) A.N. Dremin & P.F. Pokhil, "Width of the Chemical Reaction Zone of the Detonation Waves of TNT", Doklady AkadN **127**, 1245-48 (1959) & CA **54**, 23329 (1960) (Pressure, velocity & width of deton wave at different d's) 9) W.B. Garn, "Detonation Pres-

sure of Liquid TNT", JChemPhys **32**, 653-55 (1960) 10) A.N. Dremin et al, "Detonation Parameters", pp 610-19 in the 8th Symp Combstn (1962) 11) N.L. Coleburn, "Chapman-Jouguet Pressures of Several Pure and Mixed Explosives", USNOL Technical Report **TR-64-58**, June 1964, White Oak, Silver Spring, Md 12) C.G. Dunkle, "Measurements of Detonation Pressure and Temperature in High Explosives", APL Report **BBW/CGD/M-13**, 2 June, 1965, Johns Hopkins Univ, Silver Spring, Md (This report is abstracted under "Detonation Pressure and Temperature in High Explosives Measurements")

Density-Velocity of Detonation Relationship.
 See under DENSITY-DIAMETER-DETONATION VELOCITY RELATIONSHIPS

Detonation (and Explosion) by Priming and Boosting. These are means of building up a detonation from an initiating shock (Ref 2, p 294). The detonator, the first element in an "explosive train" or "explosive chain", may have three parts. The *upper* (primer, spot, or igniter) charge is usually a highly sensitive explosive which, when activated by a relatively weak stimulus, emits hot products or a weak shock causing initiation of the *intermediate* charge. This is a primary high explosive such as Lead Azide. For safety, the amount is kept at a minimum. It is customary, therefore, to stress the desirability of its sensitiveness. Its important qualities, however (Ref 2, p 181) are the capability of undergoing the DDT in an extremely short distance and time, and of propagating the detonation wave in an extremely thin column (Ref 2, p 161). The detonation carries into the *base charge* of the detonator, a secondary explosive such as Teteryl, PETN, RDX or HMX. The rest of the train consists of less sensitive but more powerful explosives to conduct the detonation to the booster and thence to the main charge. (In a *squib*, by contrast, the spit of flame from the igniter is led into one or more pyrotechnic charges or igniter compositions so that a deflagration is transmitted into the main charge.) There is for any explosive a minimum radius of curvature of the detonation front below which it will not propagate (Ref 1). The function of a booster, therefore, is to develop a detonation front having a radius of curvature longer than the minimum for the explosive being boosted (Ref 2, p 295). See also under Detonation (and Explosion), Ignition of Explosives and Propellants and also Detonation (and Explosion), Initiation (Birth) and Propagation (Growth or Spread) in Explosive Substances

Refs: 1) T.C. Poulter, "A Report on Recent Basic Studies on Detonation of High Explosives", SRI Poulter Laboratories Lab Tech Report **010-57**, May 20, 1957, SAC 14th Meeting, 25-26 April 1957 (Conf) Unclassified paper on pp 83-92 2)

Dunkle's Syllabus (1957-1958), 161, 181 & 294-95

Detonation; Principle of Similarity, Its Application in Shock Waves and Scaling Effects. See "Detonation Shock Waves; Principle of Similarity, Its Application and Scaling Effects in"

Detonation Processes: Properties of Explosives Affecting Them. This is a very broad subject and might include Chapman-Jouguet parameters (See Table under "Detonation, Chapman-Jouguet Parameters in"), thermohydrodynamic properties, brisance, density, power or strength, pressure of detonation, temperature of detonation, sensitivity to impact, sensitivity to initiation and detonation velocity

These and some other properties are called in French "Caractéristiques des Explosifs". They are listed in Vol 2 of Encycl, p C149-L as "Characteristics of Explosives and Propellants"

Some addnl refs on this subject are given in this Vol under "Characteristics of Explosives and Propellants" in Section I [Compare with "Detonation (and Explosion), Factors Influencing Velocity and Other Properties of Explosives]

Detonation (and Explosion), Products of.

Principal products formed on deton or expln are, after their cooling, gases such as: CO_2 , CO , CH_4 , HCN , N_2 , NO_2 , NH_3 , H_2 , O_2 , CH_2O , etc; vapors such as H_2O , CH_3OH & $\text{C}_2\text{H}_5\text{OH}$ and solids, such as carbon (soot), NaCl , KCl , Al_2O_3 , etc. It must be noted that before cooling (ie, at the temp of deton or expln) all the vapors and some of the solids (such as NaCl , KCl , AlO , Al_2O , Al_2O_3 , etc) are in a gaseous state

Refs: 1) Taylor (1952), 87-110 (Deton in condensed expls yielding only gaseous products); 111-38 (Deton in expls whose products contain a condensed phase) 2) A.S. Filler et al, "Calculations of Products of Detonation Using IBM", TechRept No **XXI** (1953), Univ of Utah, Contract No N7-onr-45107 3) H. Lingenberg, Ministry Fuel and Power (Brit), Safety in Mines Res Estab, Paper No **39**(1954); CA **50**,

7010(1956) (Analysis of methods for deton of deton products produced on shotfiring)
 4) Dunkle's Syllabus (1957-1958), 236, 246-47, 256-57, 274-77, 293, 357-59 & 395
 5) Cook (1958), 285-87 (Products of deton of TNT); Appendix II, pp 379-407 (Calculation of products of deton)
 6) Baum, Stanyukovich & Shekhter (1959), 13 (Volume of gaseous products of deton); 109-43 (Calculation of composition of deton products)
 6a) Zel'dovich & Kompaneets (1960), pp 269-71
 7) Andreev & Belyaev (1960), 384-409 (Composition & volume of deton products)
 8) Dunkle's Syllabus (1960-1961), pp 20a-b, 22b-c & 23a-c
 9) H.J. Goodman & R.E. Shear, "Pressure, Density and Internal Energy of Pentolite Explosion Products", BRL Rept 1212(1963)

Detonation - Product Equation of State Obtained from Hydrodynamic Data is discussed by W. Fickett & W.W. Wood in the *Physics of Fluids* 1, 528-34 (1958)

Constant- β and Constant- γ Equations of State described in this paper are given under "Detonation (and Explosion), Equations of State in", Section 2

Detonation Products, Flow Velocity of. Flow velocity of the detonation products of some gaseous mixtures were determined by L.D. Landau & K.P. Stanyukovich and reported in *Dokl AkadN* 47(3), 205-07 (1945) & *CA* 40, 4217 (1946)

Detonation Products, Thermodynamic Properties of were determined by C.L. Mader at Los Alamos Laboratory and described in Rept **GMX-2-R-59-3** (Sept 1959) and Suppl Rept **GMX-2-R-60-1** (April 1961)

Detonation Progress Thru a Column of Explosive.

Technical Manual, "Military Explosives", TM 9-1300-214/TO 11A-1-34 (1967), pp 4-9 to 4-11 (Detonation) gives the following brief description:

The hydrodynamic theory of detonation, based on physical theories of shock waves and the chemical theory of absolute reaction rates, utilizes the established laws of conservation of mass, energy, and momen-

tum. As derived, the hydrodynamic theory applies to explosives under complete confinement or in the form of cylindrical cartridges or spheres of sufficient diameter that the material near the center of the mass may be regarded as completely confined

By application of the three laws, there can be established three equations relating the five variables, pressure, density (volume⁻¹), temperature, detonation rate, and translational velocity of the gaseous molecules of the reaction products. An equation of state:

$$pv = nRT + a(v)p$$

is used; and a fifth equation is obtained by applying the physical principle that a shock wave passes thru a gas with a velocity equal to the sum of the translational velocity of the gas plus the velocity of sound in the gas at its final temperature and density. By solution of the five simultaneous equations, the characteristics of a given explosive can be calculated

From the information obtained thru the hydrodynamic theory, a mechanism of detonation can be visualized (see Fig D). After the detonator functions, a *detonation zone*, in which the chemical reaction is taking place, travels thru the column of explosive. This detonation zone is generally considered to include a very narrow *shock zone* (10⁻⁵ cm) or *shock wave*. Little or no chemical reaction occurs in this shock zone, but the pressure reaches its peak. The detonation zone includes not only this shock zone, but also the *chemical reaction zone* (0.1-1.0 cm). Following this detonation zone are the *detonation products*. In front of the shock zone is the unreacted explosive in its original state of density, pressure, velocity, and temperature. At or near the beginning of the chemical reaction zone, the high temperature to which the material is raised by compression in the shock zone initiates chemical reaction. Maximum density and pressure occur at the beginning of the reaction zone, while the temperature and velocity reach their peak at the completion of the chemical reaction. The detonation products flow with great velo-

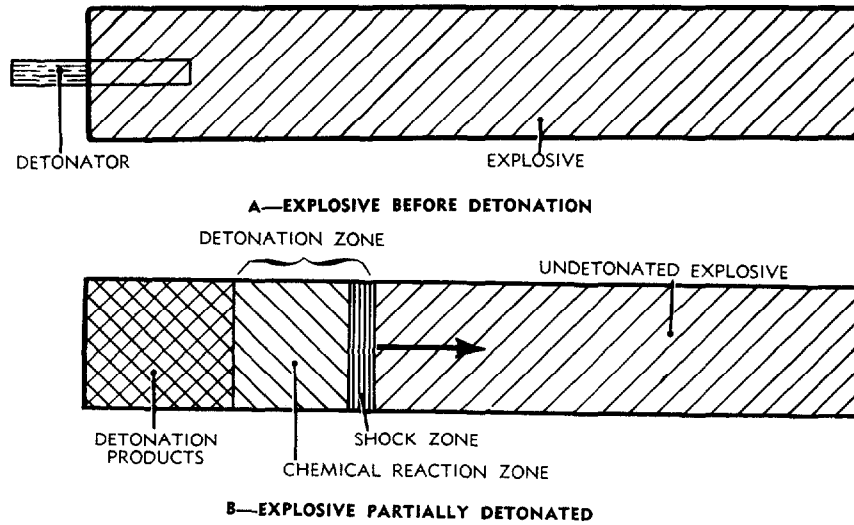

Fig D

Progress of Detonation Through
a Column of Explosive

city, but of lesser degree than the velocity of the detonation zone, toward the undetonated explosive. This is characteristic of detonation in contradistinction to deflagration, in which case the reaction products flow away from the unreacted material. The velocity of advance of the detonation zone is termed the *detonation rate*.

As each individual molecule of explosive undergoes ordinary thermal reaction starting with a low initial temperature, there is a lag effect or induction period that depends exponentially on the reciprocal of the initial absolute temperature.

With an initial temperature of 725°C, the induction period is of the order of 10⁻⁵ second.

With high initial temperatures, it appears that the last 75 percent of the reaction requires only about 10⁻¹¹ second.

On the basis of the hydrodynamic theory, the characteristics of detonation have been calculated and values for temperature of detonation, pressure of detonation and velocity of detonation are given for four explosives in Table 5.

Table 5

| Explosive | Loading density, g/cc | Temp °C | Pressure (10 atm) | Detonation velocity, m/sec |
|-----------|-----------------------|---------|-------------------|----------------------------|
| NG | 1.60 | 5370 | 1.99 | 8060 |
| Tetryl | 1.50 | 4480 | 1.48 | 7125 |
| TNT | 1.50 | 3600 | 1.10 | 6480 |
| AN | 1.00 | 1350 | 0.25 | 3420 |

Detonation, Propagation Failure of was discussed by B.E. Drimmer & T.P. Liddiard in "Propagation Failure in Explosives Under Dynamic Precompression", US Naval Ordnance Laboratory, White Oak, Silver Spring, Md, NOLTR 64-40, July 1964

Detonation (and Explosion), Propagation Through Explosive Charges.

In addn to information and references given under "Detonation (and Explosion), Initiation (Birth) and Propagation (Growth or Spread) in Explosive Substances", following refs should be consulted:

Refs: 1) Ya.B. Zel'dovich, *ZhEksper i TeoretFiz* 10, 542(1940) (On the theory of propagation of detonation in gaseous systems) 1a) J.G. Kirkwood & S.R. Brinkley Jr, "Theory of Propagation of Shock Waves from Explosive Sources in Air and Water", OSRD 4814(1946) 2) G.N. Abramovich & L.A. Vulis, *DoklAkadN* 55, 107-10(1947) & *CA* 41, 6723(1947) (Mechanism of propagation of deton and burning) 3) M. Sultanoff et al, pp 494-97 in the 4th Symp-Combstn (1952) (Propagation of deton thru hollow cylinder of Pentolite, 1.5 in OD & 1 in ID, 6 in long was studied at Aberdeen PG by means of optical recording technique) 4) S.J. Lowell, "Propagation of Detonation in Long and Narrow Columns of Explosives", PATR 2138(1955) [Due to the fact that 70/30 Tritonal in the long M26 Burster (38 in by 1 in diam) of the M122 Photoflash Bomb failed sometimes to detonate completely when properly initiated, it was decided to investigate whether other expls when loaded as long columns of narrow diams would propagate completely

Tests were conducted with unconfined columns (paper covering), 38 in long placed on a stand vertically, with lower end (which was indented, as in detonator caps) a few mm above a mild steel plate 1 inch thick. The upper end of column was provided with a Fuze. If deton propagated whole length of the column, an impression was made on the steel plate

Note: A similar test was made in Russia,

except that the columns of expls were placed horizontally on a plate (brass). If deton proceeded thru whole length, the impression on the plate was equal to the length of the column and if only partly, this was shown on the column. This test is described under Detonation, Critical Length Determination

The tests conducted at PicArnsn gave the following results: Comp B, HBX and tamped crystalline TNT detonated completely 5 times out of five. The minimum diams required were 0.75 inch. For other expls tested the min diams were 1 in for 80/20-Tritonal; 1.25 in for cast TNT and 50/35/15-Baronal; 1.5 in for 67/33-Baratol and 1.75 in for 70/30-Tritonal. These diameters are called "critical"] 5) G.J. Horvat & E.J. Murray, "Propagation of Detonation in Long Narrow Cylinders of Explosives at Ambient Temperature and at -65°F", PATR 2389(1957) 6) Dunkle's Syllabus (1957-1958), 172-76, 189-90 & 196-200 7) Cook (1958), pp 44, 50-51 & 68-89 8) Baum, Stanyukovich & Shekhter (1959), 280-82 (Propagation of deton in gases); 282-85 (Propagation of deton in condensed expls) 8a) Zel'dovich & Kompaneets (1960), 81 (Mechanics of propagation) 9) Andreev & Belyaev (1960), 254-62 (Spread of deton) 10) Dunkle's Syllabus (1960-1961), pp 14f-g, 15e-f & 17d-e

Addnl Refs:

A) N. Manson, "Propagation des Détonations et des Déflagrations dans les Mélanges Gazeux", EdOfficeNatlEtudesRecherchesAeronautiquesInstFrancPétroles, Paris (1947) (200 pp) (Propagation of detonation and deflagration in gaseous mixts) A₁) H.H. Calvitt, "Motion of the Detonation Products Behind Plane and Spherical Detonation Waves in Solid Explosives", Pennsylvania State Univ Dept of Engrg Mechanics, Tech Rept No 3, Sept 1964 B) M. Lutzky, "The Flow Field Behind a Spherical Detonation in TNT Using the Landau-Stanyukovich Equation of State for Detonation Products", USNOL - White Oak, NOLTR 64-40(1964) C) G.P. Cherepanov, "Theory of Detona-

tion in Heterogeneous Systems", ZhPrikl-Mekh i TekhnFiz 1965, No 4, pp 163-64 [A theoretical model for detonation in heterogeneous systems is proposed. Previous studies had shown a substantial difference between homogeneous combustion (in which oxidant and combustible are mixed to form a homogeneous system) and heterogeneous combustion (eg, in a tube which has its walls covered with solid or liquid fuel and is filled with air or oxygen). Owing to the heat generated behind the primary detonation wave, the evaporation or dispersion of the fuel from the walls into the combustion zone leads to periodic point explosions which form secondary detonation waves. Interaction of the primary and secondary detonation waves leads to periodic acceleration and deceleration (*pulsating*) of the primary wave. On the assumption that the average detonation velocity in the combustion zone is equal to the average local speed of sound, and by use of the conservation equations of mass, momentum, and energy, an equation was derived for calculating the detonation velocity in heterogeneous systems]

D) J.H. Lee et al, "Two-Dimensional Unconfined Detonation Waves", pp 805-15 in the 10thSympCombstn (1965)

E) B.G. Craig, "Measurements of the Detonation-Front Structure in Condensed-Phase Explosives", pp 863-67 in the 10th-SympCombstn (1965)

F) C. Fauquignon et al, "Detonation of a Cylindrical Charge - Study of the Flow of Burned Gases", pp 39-46 in the 4thONR-SympDeton (1965)

F₁) G.K. Adams & M. Cowperthwaite, "Explicit Solutions for Unsteady Shock Propagation in Chemically Reacting Media", Ibid, pp 502-11

G) J. Brossard et al, "Propagation and Vibratory Phenomena of Cylindrical and Expanding Detonation Waves in Gases", pp 623-33 in the 11thSympCombstn (1967)

H) R.I. Soloukhin, "Quasi-Stationary Reaction Zone in Gaseous Detonations", pp 671-76 in the 11thSympCombstn (1967)

I) R.A. Strehlow et al, "Transverse Wave Structure in Detonations", pp 677-82 in

the 11thSympCombstn (1967)

J) Donna Price, "Contrasting Patterns in the Behavior of High Explosives", pp 693-702 in the 11thSympCombstn (1967) (In some expls investigated by D.P.'s group the homogeneous processes play the major part in the transmission, if not the initiation, of detonation)

K) A.N. Dremin & S.D. Savrov, "On the Stability of the Detonation Front in Liquid Explosives" - in the preprinted abstract of the 11thSympCombstn (1967)

L) C.G. Dunkle, Private Communication, January 1968

Detonation (and Explosion), Propagation Through Layers of Non-explosive Substances Between Explosive Pellets.

This problem was investigated at the USBurMines and reported by C.M. Mason et al, Progress Rept Oct-Dec 1950. A brief description of this work is given under "Detonation (and Explosion) by Influence," Ref 12
Note: The non-explosive layers between explosive charges are known as *barriers*

Detonation (and Explosion), Propagation or Transfer. See "Detonation (and Explosion) by Influence or Sympathetic Detonation" and also "Detonation (and Explosion), Initiation (Birth) and Propagation (Growth or Spread) in Explosive Substances"

Detonation Properties of Explosives. See Detonation, Chapman-Jouguet Parameters and also Detonation Parameters and Characteristics

Detonation, Properties of Explosives Affecting Processes of. See Detonation Processes, Properties of Explosives Affecting Them

Detonation Properties of Pentolite were discussed by R.E. Shear in BRL Rept 1159 (1959)

Detonation Properties of Some Service Explosives. Calculation of detonation properties was done during WWII in US and is described by S.R. Brinkley Jr & E.B.

Wilson Jr in OSRD Rept 1510 (June 1943). See Detonation, Chapman-Jouguet Parameters and also Detonation Parameters and Characteristics

Detonation, Pseudo. Phenomenon of *pseudo detonation* was observed by Pangburn et al (Ref 1, p 7) during comparison of combustion modes in intermittent jet engines. The same phenomenon is also known as *unstable double discontinuity* or *latent combustion phase*

Dunkle (Ref 2, p 11e), under the heading "Coalescence of Shock and Combustion Waves", stated that if both shock wave front and combustion wave front move at the same velocity, the rapid photography camera frame in which the shock wave front is stationary and the frame in which the flame front is stationary are the same. This, however, is not always the case. Often the shock front out ahead is faster than the flame front behind it. This, in fact, is a stage in DDT (Deflagration to Detonation Transition) and has been called "pseudo-detonation"

Refs: 1) D.F. Pangburn, "A Comparison of Combustion Modes in Intermittent Jet Engines", RPI (Rensselaer Polytechnic Institute) TechRept AE 5404 (1955)

2) Dunkle's Syllabus (1960-1961), pp 11b and 11e

Detonation, Pseudopotential Theories.

W. Fickett in "Detonation Properties of Condensed Explosives Calculated with an Equation of State Based on Intermolecular Potentials", LosAlamosScientific-LabRept LA-2712 (1962), pp 38-42, reports that pseudopotential theories are obtd by an approach completely different from perturbation theories. The problem of defining a system of detonation products consisting of both solid carbon in some form and a fluid mixt of the remaining product species has been formally rearranged to a single fictitious substance with an extremely complicated compn- & temp-dependent potential function Φ , called the pseudopotential. The fictitious substance corresponding to this potential is clearly non-conformal with the components of the mixt

The order-disorder problem reqd for calculation of the pseudopotential has been solved approx by three different methods: 1) In the *moment* method, the pseudopotential is expanded in a power series, the first term of which is equivalent to the one-fluid theory 2) the *pair-correlation* method gives a more interesting first-order result - a complicated expression for the effective potential function, which contains both the compn & temp and gives the one-fluid result only in the high temp limit 3) in the *pseudo-pair-potential* method, the moment method series is rearranged into a sum of pair interaction terms plus a sum of triplet interaction terms

Fickett reports that the first order result of the moment method (one-fluid theory) is a rigorous upper bound to the Gibbs free energy, and that the pseudo-pair-potential result is a rigorous lower bound to the same quantity. Both bounds are so widely separated that they are mostly of theoretical interest. Fickett concludes that none of the pseudopotential results is simple enough to use in the complete detonation calculation

See also Detonation, Longuet-Higgins Theory and Detonation, Perturbation Theories

Detonation, Qualitative Theory of. A brief description of a qualitative theory of the variation of detonation vel with chge diameter and the effect of confinement, as described by Taylor (1952), pp 145-48 is as follows:

The fundamental hydrodynamic theory of deton refers to a chge of infinite diam or a cylindrical chge encased in a perfectly rigid tube. Of course, ideal lateral confinement can never be realized completely since even massive metal tubes are compressible under the internal pressure developed during deton

The propagation of a steady wave is detd by conditions ahead of the CJ-layer which constitutes a moving energy barrier across which no gain or loss can take place. In a cartridge under perfect lateral confinement, the CJ-layer will lie in the plane where chem equilibrium is reached. The steady zone & reaction zone then co-

incide. When the cartridge is imperfectly confined, so that the products during & after reaction can expand sideways, the CJ-condition applies at the point where the rate of pressure-rise due to reaction is equal to the rate of fall due to lateral expansion. If the rate of pressure-fall due to lateral expansion is zero, as in a well-confined cartridge, the CJ-condition applies at the end of the reaction zone. Otherwise the CJ-layer must fall within the reaction zone and may be expected to penetrate more deeply into it towards the shock front as the confinement becomes less effective. The effect of poor confinement then is to divide the course of reaction into two parts, only the first of which is effective. There is experimental evidence which shows that some expl does remain unconsumed after the deton of poorly confined chges (even in a chge such as of NG)

The above argument suggests that the wave velocity will depend upon the rate of lateral expansion relative to the rate of reaction. This relative expansion will increase as the rigidity of the confining tube or the diam of chge is reduced, or as the reaction time is prolonged. At one extreme, if the expansion is very great, the pressures & temps developed in the wave front may fall to such a low level that further propagation becomes impossible, and the wave fades out. At the other extreme, if the expansion is very small, the diam large, or the reaction time is very short, the vel of deton must approach the limiting vel to which the fundamental theory refers

This qualitative theory gives a picture of why, for any expl, there is a critical min diam below which the expl fails to detonate, another less clearly defined diam above which the expl detonates at its max and, in between, a range of diam over which the deton vel increases as the max vel is approached. It also explains why encasing the expl in a rigid tube increases the vel of deton

Detonation, Radial Expansion in. The term used by G.B. Kistiakowsky in Kirk & Othmer, Vol 5 (1950), p 958 for the phenomenon

known also as **lateral expansion or loss** used by Cook (1958), p 123. This phenomenon is called **sideway expansion** by some investigators

Detonation (and Explosion), Radiation Emitted on. See Detonation (and Explosion), Luminosity (Luminescence) Produced on

Detonation (and Explosion), Radiation Measurements in the Reaction Zone of Condensed Explosives. See Ref 73, under Detonation (and Explosion), Experimental Procedures

Detonation (and Explosion), Radius of Rupture in Underground Blast. See Vol 2 of Encycl, p B182-R

Detonation, Rankine-Hugoniot Curve in. See under DETONATION (AND EXPLOSION), THEORIES and in paper of M.W. Evans & C.M. Ablow, ChemRevs **61**, 138 (1961)

Detonation, Rankine-Hugoniot Equations and Rankine-Hugoniot Relation in. See under DETONATION (AND EXPLOSION), THEORIES and in paper of M.W. Evans & C.M. Ablow, ChemRefs **61**, 138 & 142 (1961)

Detonation (and Explosion), Rarefaction Effect in Air Blast. See Vol 2, p B180-R

Detonation (and Explosion), Rarefaction (or Expansion) Wave and Release Wave of E.M. Pugh. Even when an explosive is strongly confined in a container, such as a pipe with the end housing the initiator closed, the region of high pressure, temperature and material velocity is followed by a region in which the pressure and temperature are falling to somewhat lower values, while the material velocity falls to zero. Such a traveling region of falling pressure is called a *rarefaction wave*. Its front moves with approx the velocity D , but its back surface moves somewhat slower, actually with the velocity of sound c , in the burnt gases in the condition in which they were left after passage of the rarefaction wave. It has been shown that the detonation velocity D is equal to the velocity of sound in the heated, compressed

gases in front of the rarefaction wave plus the material velocity u , of these gases. The rarefaction wave of finite amplitude will tend to spread out instead of piling up

The rarefaction wave may affect the observed detonation velocity if rarefaction wave follows so closely on the detonation front that the region of reaction is overlapped by the rarefaction. The phenomenon of rarefaction may account for the lower velocity which is observed in narrow tubes, in which the radial (lateral) expansion also produces a rarefaction wave

In the absence of viscosity, rarefaction waves are thermodynamically reversible phenomena, that is, no change in entropy is involved and the ordinary laws of adiabatic expansion can be applied. *Shock waves*, on the other hand, are irreversible; there is a continuous dissipation of energy into heat (Ref 1)

In an "ideal" one-dimensional detonation, the expansion of the products behind the C-J plane forms a "rarefaction wave", of which the head pursues the detonation front but cannot overtake it because the wave is moving at sonic velocity in the products and they are receding from the front at just that velocity (Ref 2, pp 200-02). In an ordinary cylindrical charge (Ref 2, pp 204-06), the shape of the detonation head depends on two types of rarefactions: one from the rear, corresponding to the stag-

nation plane in the single, combined compression-rarefaction wave (Ref 2, p 260), and the other from the sides of the charge, called *release waves* (Ref 2, p 287). The term "release waves" was given by E.M. Pugh to "lateral rarefaction waves" (Ref 4, p 91). So long as the chemical reaction is completed along the axis before the release wave reaches it, the process along the axis is essentially the "ideal", "infinitely confined", "one-dimensional steady-state process", and determines the rate of advance of the entire detonation head. If, on the contrary, the column of explosive is so thin that the detonation head is shorter than a normal reaction zone, *lateral expansion* starts at the axis before chemical reaction is completed. Some energy is lost to the sides and fails to contribute toward the passing on of the *Hugoniot energy* to the undetonated explosive. Such loss causes a drop in detonation velocity below the "ideal" value

Kistiakowsky & Kydd (Ref 2) investigated rarefaction waves in gaseous detonations. Cook (Ref 4, pp 91 & 105 gave a fairly comprehensive description of rarefaction waves, including "lateral rarefaction waves", called "release waves" by E.M. Pugh

Cook also gave a diagram of "development of detonation head in an ideal detonation" (Fig 5.9, p 105), which includes "fronts of rarefaction waves"

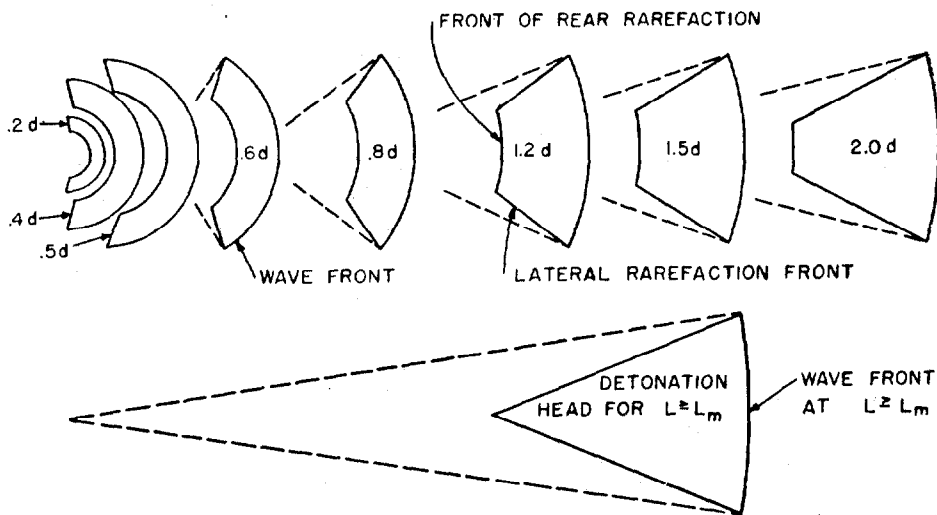

Figure 5.9. Development of detonation head in an ideal detonation with $a_0/d \ll 1.0$. (Dotted lines are directed toward point of initiation for $L \leq L_m$ and to apparent initiation point for $L > L_m$.)

Evans & Ablow (Ref 5) discussed the interposition of "side rarefaction wave"

Craig (Ref 6) reported that the *reaction zone* of falling pressure is followed by a rapid further drop in pressure which is not predicted by any extrapolation of the one-dimensional theory, and is then followed by a region of relatively slowly falling pressure. The region of rapid pressure drop he calls the *decay zone*

Refs: 1) G.B. Kistiakowsky & E.B. Wilson Jr, OSRD Rept 114 (1941), 2-4 2) G.B. Kistiakowsky & R.H. Kydd, JChemPhys 23, 271-74 (1955) 3) Dunkle's Syllabus (1957-1958), 200-02, 204-06, 260 & 287 4) Cook (1958), 91 & 105 5) M.W. Evans & C.M. Ablow, ChemRevs 61, 165-66 (1961) 6) B.G. Craig, 10th Symp Combustn (1965), 863-67 (Measurements of the Detonation-Front Structure in Condensed-Phase Explosives) 7) 11th Symp Combustn (1967) - No papers on rarefaction waves 8) 12th Symp Combustn (1968) - No papers on rarefaction waves

Detonation, Rayleigh (or Mikhel'son) Line and Transformation in.

(Called here Rayleigh-Mikhel'son Line) The Chapman-Jouguet theory deals with adiabatic transformations in steady, non-viscous, one-dimensional flows in stream tubes or ducts of constant cross-section. Such transformations can be called *Rayleigh transformations*. From the equation of continuity valid for flow of constant cross-section and from the momentum equation (Ref 1, p 117 & Ref 2, p 99), with use of the formula $c^2 = \gamma P v$ for sonic velocity in an ideal gas, can be derived the relationship:

$$\frac{P_2}{P_1} - 1 = -\gamma M_1^2 \left(\frac{v_2}{v_1} - 1 \right)$$

where P_2 and v_2 represent the pressure and specific volume at any station within the transformation region. The meaning of this equation is that for an ideal gas the path of the Rayleigh transformation in the dimensionless v, P plane is a straight line (the *Rayleigh Line*) of negative slope, and

that the magnitude of this slope is proportional to the square of the Mach number of the propagation of the transformation into the previously undisturbed region ahead of it. (In much of Europe, the Rayleigh Line is called the Mikhel'son Line) (See p 74 of Ref 4)

The points along a Rayleigh-Mikhel'son Line are characterized by constancy of *impulse function* $(P + \rho q)A$ as well as of mass velocity but not, in general, of temperature (Ref 2, p 101). Movement along such a line can represent flow without losses in a constant-area duct, with heat addition or removal and consequent changes in temperature and hence in entropy. The Rayleigh-Mikhel'son line is curved when plotted in the s, T (temperature vs entropy), the s, h (enthalpy vs entropy), and the dimensionless temperature vs density planes (Ref 2, p 173)

In the dimensionless v, P plane the Rayleigh-Mikhel'son line representing the C-J detonation reaction is tangent to the Rankine-Hugoniot curve for complete reaction (Ref 2, p 170). The point of tangency defines the end conditions of the reaction zone. It is shown (Ref 3, p 128) that in this plane $\tan \alpha = M_1^2 \tan \phi$ where $\tan \alpha$ and $\tan \phi$ are the slopes of the Rayleigh line and of the isentrope, respectively, from the negative v/v_0 axis (Ref 3, p 192). Hence, as M_1 approaches unity (for $M_2 = 1$), the Rayleigh line approaches the isentrope, of which the slope at a given point represents sonic velocity at that point

The curve of maximum entropy is the locus of end points, in the v, P plane, of all possible Rayleigh transformations starting with the "spike" state and representing release of a given quantity of chemical energy Q . Oppenheim (Ref 1) calls this the Q -curve. Its equation is derived on the assumption that the combustion products move at the local velocity of sound with respect to the detonation front. Thus the Rayleigh-Mikhel'son line at the C-J point, where it reaches the Q -curve, has the same slope as the isentrope at that point

Pangburn and Foa point out (Ref 2, p 4) that at the C-J state an infinitesimal Rayleigh transformation is adiabatic because it proceeds along a Hugoniot curve, and hence involves no change in Q . Therefore, the terminal transformation of a C-J process is adiabatic. Since adiabatic Rayleigh-Mikhel'son transformations are propagated at sonic velocity, the stationary-state condition implies that the terminal flow velocity be sonic relative to the front of the transformation region. It follows that in C-J processes the velocity of the burned gas is sonic relative to the front of the transformation (See also Refs 4 & 5)

Refs: 1) A.K. Oppenheim, 4th Symp Combustn (1953), p 474 2) D.F. Pangburn et al, "An Extension of the Chapman-Jouguet Gasdynamics of Combustion", Rensselaer Polytechnic Inst, Tech Rept **AE 5402** (1954) [ONR Contract Nonr 594(04) NR No 094-264] 3) Dunkle's Syllabus (1957-1958), 99-101, 128, 170, 173, 191-92, 200-06, 260 & 287 4) Cook (1958), 68 & 79-80 5) Zel'dovich & Kompaneets (1960), p 74 (Mikhel'son Line)
 Note: A more comprehensive description of Mikhel'son Line, which we call Rayleigh-Mikhel'son Line is given under Detonation (and Explosion) in Gases (Eq 9 & Fig A)

Detonation (and Explosion), Rayleigh Transformation. See under previous item

Detonation Rate. Same as Detonation Velocity

Detonation, Rayleigh-Mikhel'son Line. See Equation 9 and Fig A under Detonation (and Explosion) of Gases

Detonation, Reaction Front in. It is generally agreed that a detonation is a combination of a shock front and a combustion front (Ref 1, p 126 & Ref 2). Where combustion is the detonation reaction, the combustion front can also be called the *reaction front*. The two fronts do not always have the same velocity. At an interesting stage of the DDT (Deflagration to Detonation Transition), the shock front is still faster than the reaction front behind it (See under "Detona-

tion, Predetonation Phase in). This stage is normally transitory, and followed by a "hypervelocity process", in which the reaction front overtakes the shock front and a full-scale detonation is set up, with both fronts moving along together at the same high velocity

Refs: 1) Dunkle's Syllabus (1957-1958), 126 2) C.G. Dunkle, Private Communication, January 1968

Detonation, Reaction Length of. See in paper of R.E. Duff & E. Houston, "Measurement of Chapman-Jouguet Pressure and Reaction Length in the Detonation of High Explosives", JChemPhys **23**(7), 1268-73 (1955)

Detonation, Reaction Mechanism in.

Zel'dovich & Kompaneets (1960), p 217 stated that in the case of condensed expls (such as NG, cast TNT, etc) it can be assumed that the reaction mechanism does not differ essentially from that in gaseous detonation. At the detonation wave front a shock wave is moving and compressing the explosive; as a result of compression, the expl begins to react rapidly being converted into explosion products. In the case of gases it is not difficult to calculate the temperature and pressure of a shock wave of a given velocity (equal to the detonation velocity) but this cannot be done in the case of the compression of condensed expls by a shock wave whose pressure is higher than the detonation pressure (i.e. higher than 3×10^5 kg/cm²). Together with temp, pressure can also indirectly affect the reaction rate since the value of pv is of the same order as the thermal energy. For gases the pressure is related only to the number of collisions betw molecules, while the nature or quality of the collisions depends only on the temp and not on the pressure. In the case of condensed expls the pressure indirectly affects the molecular separation and alters the rate of chemical reaction

Detonation Reaction, Post. (Post or After Detonation Reaction). See Detonation, Post (or After) Reaction

Detonation, Reaction Rate in. Many authors have commented (Ref 5, p 139) on the almost uncanny ability of an Arrhenius-type equation to correlate the data on reactions of explosives and propellants. The temperature dependence of a wide variety of such reactions seems to follow the same general form. The usual plot of the logarithm of the rate, or of the reciprocal of the induction period vs $1/T$, yields an "apparent activation energy" which acts as a weighted mean or overall value for the several reactions occurring. In addition the exponential dependency is so powerful that it tends to mask all lesser effects of temperature

It has been objected that in most experiments with propellants the rate-determining step is heat transfer; reported "apparent activation energies" of 9-40 kcal seem to depend much more on the heat-transfer techniques used than on the composition of the propellant itself; the exponential form of the relationship may be purely coincidental (Ref 5, p 140 & Ref 7, pp 12a-b). It is suggested that only *spontaneous ignitions* give any theoretical basis for deducing activation energy from the temperature coefficient of ignition delay

An alternative explanation is offered by *absolute reaction rate theory*: passage of the reacting molecule by continuous change of the thermodynamic coordinates from an initial configuration over into a final one thru a critical intermediate configuration called "activated complex". This may be formed with a large entropy increase, and hence increase the probability of completion of the reaction

As noted by Eyring, the rate of chemical reaction does not affect the detonation velocity nor any of the properties of the products (Ref 5, p 215). These properties at any point within the chemical reaction zone are determined only by the extent of completion (n), of the chemical reaction at that point, and not by the nature of the chemical reaction itself. This relation-

ship is supported by Cook's statement (Ref 1) that if the NDZ (von Neumann-Döring-Zel'dovich) theory were correct, the relationship between pressure and (n) would be effectively fixed by Rayleigh-Mikhel'son line conditions and therefore related to the pressure-distance profile thru the reaction rate

The smallness of the temperature coefficient in initiation and detonation has led to one objection to the thermal theory. It is suggested that the objection can be overcome if initiation temperature is independent of the size and duration of the hot spot and if these latter quantities are important only as they influence the hot spot temperature. In these spots, at least, the temperature in the shock front may be high enough to initiate chemical reaction in the ordinary sense. This brings both initiation and the subsequent chemical reaction into the domain of ordinary chemical kinetics (Ref 5, p 216)

Cook et al (Ref 2, p 374) note that of all the possible reactions going on in the detonation zone, only one will be rate-controlling. It may then be assumed that all other reactions are effectively in equilibrium, and (n) will then also have the significance of measuring (approximately at least) how far the critically slow reaction has proceeded toward equilibrium. They derive an expression for the ratio of the time lags, between heating and explosion, and the detonation front temperature and at the C-J temperature. They suggest that in the detonation front, chemical reaction is merely initiated, and proceeds to only a slight extent, the major portion occurring at the C-J temperature.

Cowperthwaite and Adams (Ref 10) show from details of the energy distribution in the reactive wave at various times, how the propagation of a reactive shock depends on the flow conditions behind it. Soloukhin (Ref 9) conducted a study of the hydrodynamic structure of an exothermic reaction zone behind a nearly one-dimensional shock. Measurements were made in shock

tubes by means of impulse piezogages and schlieren interferometry techniques, with use of a compensating regime to obtain sufficiently long induction zones. In these experiments, two kinds of flow patterns were examined to avoid "spinning" effects: supported incident waves in a constant-area tube, and self-sustaining detonations in a gas preheated to a high temperature by shock waves

The induction time data and density profiles of detonations in oxy-hydrogen and oxy-methane mixtures were analyzed on the basis of the kinetic data obtained by the reflected-wave technique and similar methods. A plot of the ignition delay vs $1/T$ in oxy-ammonia mixtures gave a straight line with a slope corresponding to an activation energy of 42.5 kcal/mole. In these mixtures the induction zone is not uniform, but the shock front is flat and end of the reaction zone is clearly discernible. One-dimensional detonation waves of low Mach number but relatively stable were obtained in a gas preheated to 600-1800°K ahead of the shock front

Chapter 6 in the book of Cook is devoted to "Reaction Rates in Detonation" (Ref 6) and Refs 3 & 4 by Cook et al to determination of reaction rates in TNT. Tell (Ref 8) discusses the rate of reaction at high pressure. J. Peeters & A. VanTiggelen presented paper No 41 entitled: "Experimental Determination of the Rate of Chemi-Ionization Processes" (Ref 12)

Refs: 1) M.A. Cook & W.O. Ursenbach, "Reaction Rate of Sodium Nitrate in Detonation", 2ndONRSympDeton (1955), 396ff
 2) M.A. Cook et al, TrFaradSoc 52(3), 369-84(1956) (Mechanism of detonation)
 3) M.A. Cook et al, JChemPhys 24, 60-7 (1956) (Velocity-diameter and wave shape measurements and the determination of reaction rates in TNT)
 4) M.A. Cook et al, Ibid, 191-201(1956) (Rate of reaction of TNT in detonation by direct pressure measurements)
 5) Dunkle's Syllabus (1957-1958), 139-40 & 215-16
 6) Cook (1958), 123-42 (Reaction rates in detonation) (14 refs)
 7) Dunkle's Syllabus (1960-1961),

pp 12a-b 8) E. Tell, JChemPhys 36, 901-03(1962) (On the speed of reaction at high pressure) 9) R.I. Soloukhin, "Quasi-Stationary Reaction Zone in Gaseous Detonation", 11thSympCombstn (1967), pp 671-76 10) M. Cowperthwaite & G.K. Adams, "Explicit Solutions for Steady- and Unsteady-State Propagation of Reflected Shocks", Ibid, pp 703-11 11) C.G. Dunkle, private communication, Jan 1968 12) 12th-SympCombstn - see in the text

Detonation, Reaction Zone in. When a stick of explosive is detonated from one end, the chemical reaction which completely transforms the stick to burnt gases is of extremely short duration and for this reason the layer where the reaction takes place is very narrow. This layer is known as *reaction zone*. It is that part of the *detonation zone* which is behind the very thin *shock zone*. A mathematical plane dividing the untouched explosive from the burning material travels along the stick with velocity D , followed very closely by the plane which divides the burning material from the essentially completely reacted gases. The rise in pressure P , temperature T , and mass velocity U , takes place in this narrow reaction zone (Ref 1)

At or near the forward boundary of the reaction zone, the high temperatures and pressures due to shock compression initiate chemical reaction. As the material moves toward the rear boundary of the zone, there is a continuous fall in pressure due to the expansion or rarefaction, along with a continuous rise in temperature due to the heat evolved in the reaction (Ref 3, pp 221 & 230). As noted by B.G. Craig of LASL in oral discussion during the 10thSymp-Combstn, pp 863-67, the pressure drop as reaction proceeds and energy is released seems contrary to common sense at first, but comes about because the speed of the detonation wave is controlled by the shock velocity in the unreacted material. The flow behind the shock adjusts so that the whole structure moves along together. As the reaction releases energy, the pressure

corresponding to the (fixed) wave speed falls, principally because the temperature in the material is rising

Under the prevailing temperature and pressure conditions (Ref 3, p 190), the weak molecular attractions must be negligible compared to the mean molecular energies. This accords with the employment by Kihara and Hikita, in their equation of state. [See under DETONATION (AND EXPLOSION), EQUATIONS OF STATE IN (AND SOME OTHER EQUATIONS)]

Investigation of the reaction zone structure by measuring the electrical conductivity of explosion products for condensed expls was described by Hayes (Refs 7 & 9). The work on energy distribution in the reaction shock wave was discussed by Cowperthwaite & Adams (Ref 12), and the investigation of the reaction zone by impulse piezogages and Schlieren interferometry techniques was reported by Soloukhine (Ref 10). Use of Schlieren interferometry was also reported by Struck and Reichenbach (Ref 11), who used it in order to observe the density distribution and visualize the flow field. The interferograms yielded information on the structure of the reaction zone of the combustion waves and gave a better insight into the development from initial deflagration to fully established detonation

Refs: 1) G.B. Kistiakowsky & E.B. Wilson Jr, OSRD Rept 114, p 2 (1941) 1a) Taylor (1952), 169-84 (Nature of reaction zone) 2) S. Paterson, "The Structure of the Reaction Zone in a Detonating Explosive", 5thSympCombstn (1955), pp 672-84 3) Dunkle's Syllabus (1957-1958), 169, 190, 221-22 & 230 4) Cook (1958), 68-75 (Detonation reaction zone in ideal gases); 75-77 (Detonation reaction zone in nonideal gases); 77-79 (Reaction zone in condensed expls); 138-40 [Measured reaction zones in Ditekite 13 (MNB/HNO₃/H₂O-24.2/62.6/13.2) and Nitromethane]; 147, Table 7.3 (Comparison of reaction-zone lengths of current theories with steady-state ionized-zone lengths determined with probes in 5.1-cm diameter charges) 5) E. Strömsöe, Re-

search Applied in Industry 13(3), 101-04 (1960) (Reaction zone length and failure of detonation in azides) 6) Dunkle's Syllabus (1960-1961), p 13b (A brief description of the work of Cook et al with Ditekite 13, using "shock-pass-heat-filter"); p 19d (A brief description of the work of Strömsöe listed here as Ref 5) 7) B. Hayes, "Electrical Measurements in Reaction Zones of High Explosives", 10thSympCombstn (1965), pp 869-74 7a) B.G. Craig, "Measurements of the Detonation-Front Structure in Condensed-Phase Explosives", Ibid, pp 863-67 8) M.L. Pandow et al, "Studies of the Diameter-Dependence of Detonation Velocity in Solid Composite Propellants, I. Attempts to Calculate Reaction-Zone Thickness", 4thONRSympDeton (1965), pp 96-101 9) B. Hayes, "On Electrical Conductivity in Detonation Products", Ibid, pp 595-601 10) R.I. Soloukhine, "Quasi-Stationary Reaction Zone in Gaseous Detonation", 11thSympCombstn (1967), pp 671-76 11) W.G. Struck & H.W. Reichenbach, "Investigation of Freely Expanding Spherical Combustion Waves Using Methods of High-Speed Photography", Ibid, pp 677-82 12) M. Cowperthwaite & G.K. Adams, "Explicit Solution for Steady- and Unsteady-State Propagation of Reflected Shocks", Ibid, pp 703-11 13) C.G. Dunkle, private communication, January 1968 14) 12th-SympCombstn (1968) (Pub 1969) - No papers on reaction zone

Detonation; Reflected Shock Hugoniot and Isentrope for Explosion Reaction Products, Measurements of. This subject was discussed by W.E. Deal in Physics of Fluids 1(6), 523 (1958)

Detonation, Reflected Shock Waves in Air Blast. See Vol 2 of Encycl, p B182-L and Fig on p B183

Detonation, Reformation of. This is the process which occurs after a detonation is interrupted by a barrier such as a SPHF

(shock-pass-heat-filter), if the shock which passes the barrier is strong enough for a new detonation to develop (Ref)

The SPHF method is described in Section 4, DETONATION (AND EXPLOSION), EXPERIMENTAL PROCEDURES, (Ref 40) and in Cook (1958), pp 187-94

Ref: C.G. Dunkle, private communication, January 1968

Detonation, Relaxation in. Strong compression of a substance, in a time of the order of the interval between molecular collisions, disturbs thermodynamic equilibrium and initiates internal readjustments called relaxation processes, which tend to restore equilibrium (Ref 1). If the relaxation time is considerably longer than the interval between molecular collisions, a substantial change in the structure of the shock wave results. It must be thick enough to allow vibrational equilibration, which takes longer than the translational and rotational. The thickness of the transition region may be relatively great, depending on the pressure and temperature behind the shock front as well as on other factors (Refs 4 & 7). The same considerations apply to the shock front in a detonation

Data on vibrational relaxation times from interferometric studies, reported by White and Moore (Ref 8), show the rapid decrease of relaxation time with rise of relaxation zone temperature. Addition of up to 1% H_2 to O_2 is shown to reduce the relaxation time and accelerate the reaction, but not to affect the maximum density. At a pressure of 0.001 atm, about 0.8 torr, the relaxation times would be in milliseconds instead of microseconds. The induction times for exothermic reaction are inversely proportional to the square root of the product of the number of moles of oxygen ($[O_2]$) and the number of moles of hydrogen ($[H_2]$), per liter, over the entire $[H_2]/[O_2]$ range, to a good approximation. The product of the induction time and that square root decreases with rise in temperature. The vibrational relaxation times even for the mixtures rich in hydrogen, which have

the longest relaxation times, are shorter than the induction times, at least for temperatures in the range 1000-2000°K

Investigations of vibrational relaxation times are reported in five papers of the 11th Symp Combustn (Refs 9, 10, 11, 12 & 13)

For experimental investigation of relaxation rates in shock waves, Resler & Scheibe (Ref 2) described an instrument which combines the schlieren technique, a photomultiplier tube, and an oscilloscope to measure the density distribution behind shock waves in a shock tube. In their shock tube a shock front with a relaxation zone behind it passes thru the light beam of the schlieren system. If the length of the relaxation zone behind the shock wave is less than the width of the schlieren light beam, the recorded signal from the photomultiplier tube will give the density distribution behind the shock wave (assuming that the index of refraction of the gases does not change within the transition zone) as the shock wave plus transition zone enters the light beam. By measuring these density distributions it was possible to determine the way the gas or gases relax to equilibrium after the enthalpy of the medium is increased suddenly to a calculable extent by a shock wave (Ref 4, pp 57-8). See also Refs 3, 5, 6 & 7

Refs: 1) S.P. Dyakov, ZhurEksper i Teoret-Fiz **27**(c), 728-34 (1954) 2) E.L. Resler Jr & M. Scheibe, "An Instrument to Study Relaxation Rates Behind Shock Waves", Presented at the 21st Annual Chemical Engineering Symposium (Pulsating and Vibrational Phenomena), Cincinnati, Ohio, 7 & 8 Jan 1955 3) S.J. Lukasitz & J.E. Young, JChemPhys **27**(5), 1149-55 (1957) (Measurement of vibrational relaxation time in nitrogen by means of an acoustical resonance cavity) 4) Dunkle's Syllabus (1957-1958), pp 57-8 & 389 5) M. Salkoff & E. Bauer, JChemPhys **29**, 26 (1958) (Vibrational relaxation times in oxygen) 6) K.E. Shuler, JChemPhys **30**, 1631-32 (1959) (Analysis of vibrational relaxation data in shock wave experiments)

- 7) Dunkle's Syllabus (1960-1961), pp 5d & 5e 8) D.R. White & G.E. Moore, "Structure of Gaseous Detonation, IV. Induction Zone Studies in H_2-O_2 and $CO-O_2$ Mixtures", 10th Symp Combustn (1965), pp 785-93 9) D.G. Rush and H.O. Pritchard, "Vibrational Disequilibrium in Chemical Reactions", 11th Symp Combustn (1967), pp 13-22 10) K.N.C. Bray and N.H. Pratt, "Conditions for Significant Gasdynamically Induced Vibration-Recombination Coupling", *Ibid* (1967), pp 23-36 11) J.W. Rich & R.G. Rehm, "Population Distributions During Vibrational Relaxation of Diatomic Gases", *Ibid* (1967), pp 37-48 12) R.L. Taylor, M. Camac & R.M. Feinberg, "Measurements of Vibration-Vibration Coupling in Gas Mixtures", *Ibid* (1967), pp 49-65 13) J.H. Kiefer & R.W. Lutz, "The Effect of Oxygen Atoms on the Vibrational Relaxation of Oxygen", *Ibid* (1967), pp 67-76 14) C.G. Dunkle, private communication, Jan 1968

Detonation, Release Wave Theory or Lateral Rarefaction Wave Theory. See under Detonation, Geometrical Model Theory of Cook

Detonation (and Explosion), Resistance to.

An interpretation of the fact that, for some explosives at least, the detonation velocity does not continue to rise with rise in density, but goes thru a maximum and detonation finally fails when the density exceeds a critical value is rephrased by Dunkle (Ref 5) and Price (Refs 9 & 10). Roth (Ref 4), on the basis of results reported in Refs 1, 2 & 3, suggests the existence of a property he calls *Widerstand* ("resistance" or "impedance") of value equal to the product of loading density and detonation velocity, analogous to acoustic impedance and shock impedance (See abstract of Roth's paper at the end of this item)

Gordon (Ref 8) attributes the effect of density to its strong influence on the detonation pressure. The log of the diffusion coefficient is approximately proportional to the inverse cube of the density. Thus, in composite explosives the reaction slows

down as density is increased, and at high enough density such expls should be impossible to detonate even at large diameter. In molecular explosives, on the other hand, the log/log plot of detonation velocity vs density is a straight line, of positive slope. In homogeneous colloided propellants the rates of the reactions become important, there is no such thing as particle size, and density should have little or no influence. The important factor with these propellants is whether the precursor shock is strong enough to initiate detonation

According to Drimmer and Liddiard, however (Ref 7), quenching of detonation under high compression may be a general phenomenon of explosives. The well-known dependence of detonation velocity (D) on the initial bulk density (ρ) of the explosive is nearly linear, as the density increases from about 0.5 to 1.0 times the theoretical maximum or voidless, density (TMD). When the density of the undetonated explosive *exceeds* the TMD by about 5-10%, however, the D -vs- ρ curve apparently leans all the way over, and the velocity of the wave drops to that of an inert shock; i.e. the detonation fails to propagate. Steady-state detonations are stopped on entering a zone in a solid explosive already under compression by a 5-20 kbar shock

Other evidence indicates that the pre-compression need have no dynamic character, to cause quenching of the detonation. All that is required is the achievement of an initial density above a critical value. In general, this critical value depends on the charge dimensions; the smaller the charge, the lower the critical density. For some explosives this density may be lower than the TMD at atmospheric pressure; for instance, MF & LA, under certain conditions, will not support a high-velocity detonation at densities near crystal (See "Dead-Pressed Explosives" in Vol 3 of Encycl, p D20)

For many military explosives the critical density is roughly 8% above the "voidless" density, and can be reached by dynamic compressing of the explosive with

a shock wave having a peak pressure of 5-20 kbar. The quotation marks around the word voidless emphasize the fact that in these tests the compressed explosive contained many voids, even though the bulk density exceeded the density it would have had without voids at 1 atmosphere pressure

It was concluded that steady-state propagation of detonation in solid explosives requires some kind of energy-focusing mechanism, such as provided by "hot-spots", which can be literally eliminated by precompression. Cook (Ref 6) gives crystal densities of many high explosives

Dr Langhans (Ref 4a) gave a comment (in German) on Dr Roth's paper (Ref 4), which can be approx translated as follows: Dr Roth tries to interpret the meaning of the known fact, that explosives under high compression are no longer detonable without exception. Of the fact that substances under especially high compression behave otherwise than in their usual structure, the best example is black phosphorus, first prepared in 1914 by P.W. Bridgman. This, at high temperature, forms a surrounding layer of thickly-packed phosphorus oxides so quickly that the phosphorus is shielded, and can be ignited by a burning match only with difficulty. This is also a case where the ignition process is impeded

About the "limiting density" (Grenz-dichte in Ger), to which Dr Roth should be thanked for referring, there are two possibilities of explanation: Either there occurs with rising compression a sintering of the material with loss of the internal surfaces, whereby the initial shock encounters at rising density a decreasing area for attack, or the initiation depends on adiabatic compression of confined air for reaching the ignition temperature. Air, however, and with it the possibility of this compression, is lacking at very high density. To both these explanations the author adds a new factor: resistance of the explosive, as product of the density and the detonation velocity, analogous to resonance (impedance?) according to hydrodynamic theory, set up as is well known by Roth. The author finds some corroboration of this interpretation

test in the experiments of Le Roux (Ref 3), Friederich (Ref 1) and Médard (Ref 2). Thereby were defined critical ranges for thoroughly flattened infantry projectiles weighing 8.1 g, above which the detonation was triggered. The following results were obtained for PA (Picric Acid) at different densities:

Table

| Loading density, ρ_0 | Limiting projectile velocity, V, in m/sec |
|---------------------------|---|
| 1.0 | 370 to 393 |
| 1.3 | 616 to 676 |
| 1.5 | 943 to 980 |
| 1.6 (pressed) | 1065 |
| 1.65 (cast) | No detonation |

From these exptl results, Dr Roth derived the formula:

$$V = 0.125 (\rho_0 D) - 340 \text{ m/sec}$$

where: D = detonation velocity in m/sec

Dr Langhans' Note: Some of the irregularities appearing in the experiments can be easily explained, in that not only the kinetic energy of the projectile must be considered, but also its temperature, which can vary according to the intensity of the friction in the rifle barrel, and also according to the possibility of heating during flight thru the air

Mr. Dunkle's Note: Detonation velocity of Picric Acid is given in PATR 1740, Rev 1, as 5270 at density of 1 and 7350 at density 1.6 (cast). Roth's formula would give, for V, 319 at density 1, and 1131 at density 1.6
Refs: 1) W. Friederich, SS 28, 244-47 (1933) (On the detonation of explosives) 2) L. Médard & M. Cessat, MAF 23, 195-203 (1949) (Normalized investigation methods for explosives) 3) A. Le Roux, MP 33, 283-321 (1951) (Detonation of explosives by impact of projectiles of high velocity) 4) J.F. Roth, "Über den Widerstand eines Sprengstoffes gegen seine Detonation-Deutung der Versuche von Le Roux" (On the Resistance of an Explosive to its Detonation. Interpretation of Experiments of Le Roux),

Nobelhefte **20**, 142 (1954). Quoted from résumé of Dr Roth's paper in Ref 4a
 4a) A. Langhans in *Explosivst* **1956**, p 114 (See abstract in the text) 5) Dunkle's Syllabus (1957-1958), Table XIV, p 213 shows that for Dynamite No 1 deton vel is 1900 m/sec at density 0.63 and it reaches maximum 6800 m/sec at d 1.62, falls to 2460 at 1.71 and then detonation fails at d 1.74. For Cheddite 90 bis velocity is 2283 m/sec at d 0.70 and it reaches max of 2901 at d 1.17; then it begins to fall, reaching 2451 at d 1.40; deton fails at d 1.50 6) Cook (1958), p 236, Table 10.2 (Crystal densities of HE's) 7) B.E. Drimmer & T.P. Liddiard Jr, "Propagation Failure in Solid Explosives Under Dynamic Pre-Compression", USNOL, White Oak, Silver Spring, Md, Technical Rept **TR 64-40** (1964) 8) W.E. Gordon, "Detonation Limits in Composite Explosives", 10th-SympCombstn (1965), pp 833-38 9) Donna Price, "Contrasting Patterns in the Behavior of High Explosives", 11thSympCombstn (1967), p 695, Fig 4, which shows that for Group 2 explosives deton vel at first increases with density, then it falls, and finally the detonation fails) 10) D. Price et al, "Explosive Behavior of Ammonium Perchlorate", *Combustion & Flame* **11**, p 419, Figs 5 & 6 (1967) (Detonation velocity vs density of AP curves show that increase of density above critical values results in failures) 11) C.G. Dunkle, private communication, Jan 1968

Detonation, Resonance Radiation Behind Shock Waves in Xenon is discussed by W. Roth, *JChemPhys* **31**, 844-45 (1959)

Detonation, Retonation Caused by the Reflection of Divergent Waves in.

When a shock wave is transmitted from a metal to a solid expl a pure shock wave is transmitted into the expl. The shock generally builds up to a complete detonation wave but in some cases it fails to initiate the expl. In the former case an effective delay time is observed. Initiation delay times have been measured in 2-inch diam chges of 60/40 RDX/TNT

as a function of incident shock strength in mild steel & Al. These shock initiation phenomena occur in chges with nominally plane initial shocks (Ref 1)

Marlow (Ref 2) describes an experimental investigation of phenomena resulting from weak, localized impact on a solid expl which generates a spherically diverging shock. Impact conditions were found which caused a low-order disturbance to travel thru the expl until a barrier was reached, where the barrier compn & geometry determine whether or not detonation occurs in the reverse direction. The initiation and retonation phenomena associated with divergent waves in 12 cm diam 6 cm long cylindrical chges of HMX/TNT were illustrated by streak & framing camera records. A weak divergent disturbance traveling at ca 2.7 mm/ μ sec was generated by a shock transmitted from a thin coaxial rod. This disturbance propagated thru the chge and when it was reflected from a thick steel plate it was sufficiently strong to cause detonation in the reverse direction. When steel was replaced by Perspex, the reflected wave was too weak to cause detonation

Refs: 1) W.R. Marlow & I.C. Skidmore, *PrRoySoc* **246A**, 284-88 (1958) 2) W.R. Marlow, "Retonation Caused by the Reflection of Divergent Waves", 4thONR-SympDeton (1965), 426-31

Detonation; Riemann Condition, Riemann Equation, Riemann Formulation, Riemann Function, Riemann Invariant and Riemann Variant. See under DETONATION (AND EXPLOSION), THEORIES OF; also in Dunkle's Syllabus (Ref 93, pp 43, 187 & 260) and in paper of M.W. Evans & C.M. Ablow, *ChemRevs* **61**, 133 & 144 (1961)

Detonation, Rubber Bonded Sheet Explosives. Mechanical and detonation properties of such explosives are discussed by W. Kegler & R. Schall in the 4thONRSympDeton (1965), pp 496-50

Detonation, Scabbing and Spalling of Solids in. See Detonation, Spalling and Scabbing of Solids in

Detonation, Scaling Effects. See under "Detonation Shock Waves. Principle of Similarity, Its Application and Scaling Effects in"

Detonation, Schweikert Theory of.

Dr Gustav Schweikert of Bad Godesberg, described in *Explosivstoffe* 3, 197-200 (1955) and 4, 10-14 (1956) a theory of detonation of condensed-phase explosives, which is based on the assumption that such detonations follow essentially the same basic laws as the combustion of colloidal propellants, and can be comprehended thru the same molecular and reaction-kinetic theories

Since an abstract of this article was not found in CA or PhA, Mr. C. G. Dunkle, at our request, translated the entire paper into English. However, because of the detailed mathematical derivations and numerous equations involved, we are giving an abstract prep'd by Mr Jack Alster of Picatinny Arsenal

Based on a molecular kinetic model, Schweikert derives equations which describe both the process of detonation in a condensed expl and that of the burning of a colloidal powder. These processes are shown to differ primarily in the magnitude of the collision efficiency. Relations are derived which relate the max deton vel and pressure with molecular props

Schweikert's theory differs radically from the conventional thermohydrodynamic Chapman-Jouguet theory in that it provides for a continuous transition from burning to deton. In Section I entitled "Introduction", the author criticizes the validity of the C-J theory for condensed expls. In Section II the burning rate constants of a colloidal propellant are related to fundamental parameters such as specific surface & vol of the powder, the most probable molecular vel, and the collision efficiency c . Schweikert arrives in Section III at the conclusion that burning & deton differ primarily in the magnitude of c ; i.e. $c \sim 1$ in a deton and is a much smaller value in a burning process

A surprisingly simple relation is derived in Section IV for the upper boundary of the deton vel D_m of a condensed expl:

$$D_m = \frac{\epsilon \rho}{2\tau}$$

where ρ = the av radius of the molecules,
 τ = av duration of collisions among them
 ϵ = a constant

In Section V a more general relation for D is derived which introduces the diameter effect

$$D = \frac{\epsilon \rho}{2\tau} - \frac{Q}{q} W_1$$

where q = cross section of a cylinder of expl
 O = the cylindrical surface of an infinitesimal vol element dv
 W_1 = the radial velocity of molecules streaming thru O

A Picatinny report by C.V. Bertsch, "Theories of Detonation and Burning", PA SFAL TR 2268 (1956) briefly describes a theory similar to that of Schweikert

Detonation, Sensitivity of Explosives to.

The *sensitivity of explosives* has been defined by Koenen et al (Ref 10) as the minimum amount of energy that must be imparted to the explosive, within limited time and space, to initiate explosive decomposition. This definition is, accdg to Maček (Ref 13, p 60) meaningful and can serve as a basis of quantitative fundamental treatments provided the imparted energy is thermal and provided its initial distribution in time and space is known. The accuracy of treatments of *thermal explosion* described in Section IIA of Maček's paper is then limited mainly by the accuracy of chemical kinetic data

Accdg to Maček (Ref 13, p 41), the practical problem of sensitivity of explosives can be viewed as one of reliability and of safety. This means that an explosive must be detonable reliably whenever necessary and it must not explode accidentally. The need to know how to detonate expls when and only when desired is tantamount to the need of knowledge of their behavior under all effects of externally imposed physical conditions, and this is of exceedingly large scope. Of direct interest, however, are only those conditions which may normally be encountered in practice

The fact that some explosives are more sensitive than others and detonate more easily is the basis of the conventional division of all expls into two broad classes, *primary explosives* (or primaries) and *high explosives* (HE's). Primaries are usually

thought of as expls which can be detonated by a *hot source*, such as a *resistance bridge wire*, *hot sparks*, or *exploding wires*. They can also be detonated by *friction*, *impact*, *irradiation by light*, *X-rays*, *energetic particles* or by *ultrasonics*. By contrast, HE's would be those which can be detonated only when in contact with, or in the vicinity of, another detonating explosive. This division according to behavior, while sometimes convenient, is arbitrary and cannot be made rigorous. It is known that, given proper conditions, all explosives can be detonated starting from a purely thermal source, and that under other conditions, most expls can burn or deflagrate without detonation. Moreover, there are HE's (like PETN, Tetryl, RDX or HMX) which approach primaries in detonability. These expls, which are less sensitive than primaries and more sensitive than typical HE's like TNT, PA or Comp B, are suitable for use in *boosters*. These devices are intermediates between primers and HE's used as *bursting charges* in bombs or shells

Another type of substance, which is less sensitive than primaries, is the class called *propellants*. They are explosive but formulated with different intention than HE's. Their function is to burn in a controllable fashion and, ideally, not to detonate under any circumstance. An important property of propellants is their *sensitivity to ignition*, which can be determined by subjecting them to sparks or flames

In order to understand more thoroughly the phenomenon of sensitivity of expls, Maček (Ref 13, p 43) considers a hypothetical case of an explosive in which the chemical reaction is originally started by an external energy source and is allowed to grow in violence until the extreme regime of detonation is attained. Then the process of build-up can be divided into four stages of development

The 1st stage, termed *initiation*, is one in which the reaction has not yet released sufficient energy for selfpropagation and hence is dependent on an external source of energy. If the latter is removed

before the completion of the initiation stage, the reaction will die out. If the external source is supplied with the express purpose to start pressure-controlled burning (such as in deflagration of propellants), the term *ignition* is more suitable, because initiation is a more general term applicable to a variety of situations

Initiation is followed by the 2nd stage, *deflagration*, known also as the *steady-state surface combustion* (Ref 13, p 49). It is a self-sustained reaction in which the energy is transmitted from the burning to the unburnt layers of the substance by means of surface transport properties consisting of burning, which is a relatively slow process. The linear deflgrn rate can be considered to be a function of ambient pressure only; consequently, steady states are attainable at constant pressures. Specifically, for condensed expls the linear deflgrn rate is a monotone increasing function of pressure, a fact which plays an important role in the self-acceleration of explosive reactions

The 3rd stage, *transition from deflagration to detonation* (DDT), is the stage during which the reaction accelerates from the slow transport-determined steady state to supersonic speeds. In condensed explosives the velocity of propagation during transition must increase by a factor of about a million

The 4th stage, *detonation*, is again a steady regime, but here the energy liberated in chemical reaction is transmitted to the unburnt layers of explosive by means of *shock waves*. While transport phenomena play a part in the propagation, an excellent first approximation which fully accounts for properties such as detonation pressure, velocity and energy, i.e. the Zel'dovich-von Neumann-Doering theory (described in this writeup as "Detonation, NDZ Theory in") was developed in 1940's on the basis of hydrodynamics alone

It must be noted that the above four stages of development are not necessarily well defined in every experiment or accident. For example, in a situation in which the energy of initiation is supplied as a

strong externally imposed shock, there is no deflagration stage or, if there is any, it is negligible. In cases where stimulus of initiation is not sufficiently strong, there is a period of deflagration but no full-grown steady-state detonation at velocities of 5 to 8 km/sec. Instead of this (as happens with NG), there develops a *low-order detonation regime*, known also as *metastable subdetonation regime*, which differs essentially from the hydrodynamically defined steady-state detonation. The above discussion shows that concept of initiation is inherently tied to the type of initiating stimulus

The four-stage classification described by Maček is comparable to Bowden's *three-stage division* into *initiation*, *growth*, and *explosion*. Indeed, Bowden himself (Refs 2, 3 & 8) makes clear that impact-initiated explosions, which he studied extensively, started as deflagrations and only occasionally developed into detonations (Ref 13, pp 42-3)

The unified approach adopted by Maček assumed that all initiations are ultimately thermal. More precisely: every initiating stimulus (shock, impact, electric discharge, friction, etc) serves to heat up the explosive or a portion thereof, initially at a temperature T_0 , to an elevated temperature T . It is assumed that T and the length of time t the explosive is exposed to T are the two variables sufficient to account for initiation. The 3rd factor influencing the reaction rate, density ρ , is important in gaseous combustions and explosions where it varies considerably with temperature and pressure; in homogeneous solids and liquids it is nearly constant

Furthermore it is stated by Maček that deflagration, transition to detonation, and detonation stages arise and propagate when, and only when T is sufficiently high to maintain rates of chemical reaction requisite for the three respective phenomena (Ref 13, p 43)

Since the mechanism of degradation into heat in detonations depends on the nature of the stimulus, it has become customary to recognize the following types of

sensitivity: *heat sensitivity* - when the initiating stimulus is direct application of heat and, more frequently used, sensitivities to *shock*, *impact*, *radiation* and *friction*, in which the heat is developed by stimulus during the test. It is customary in determining sensitivities of expls to report the results of several different tests, such as impact (or fall) test, shock test, gap test, and friction test

It was mentioned at the beginning of discussion on sensitivity that the accuracy of treatments of thermal explosions is limited mainly by the accuracy of chemical kinetic data. If, however, the initiating energy is not supplied directly as heat, there is an additional requirement of quantitative assessment of conversion of the stimulus into heat. Since the process of growth of detonation necessarily entails shock waves, the conversion of the mechanical energy of a shock wave into heat is a most important problem in studies of sensitivity. This means that, in addition to chemical kinetics, one must know the equation of state of the explosive under very high pressures. Both chemical kinetics and the equation of state must be known for a fundamental appraisal of initiation and growth of explosion in the routine gap and impact tests and, in addition, one must be able to calibrate the initiating stimuli. The two specific and only partially solved, problems of the gap tests are the determination of the total initiating impulse, $\int p dt$, and the effect of lateral interactions (The latter can be eliminated if the experimental arrangement is uni-dimensional, but routine gap tests are not). Both problems can, in principle, be solved by hydrodynamic methods; the practical problem is measurement under extremely high transient pressures. In the impact test, the pressures are such that the total impulse of the stimulus can be measured, but mass and energy losses in all three dimensions are so pronounced that a determination of the portion of energy absorbed by the sample is not possible. Moreover, the effects of heterogeneity and consequently the energy distribution during the test are less well known than in the gap test. Thus, while gap test-

ing is becoming a science, impact testing remains essentially an art

In Section II of Maček's paper (Ref 13, pp 44-50) is discussed the "Thermal Explosion Theory". It will be discussed in our writeup separately. Section III contains "Transition from Deflagration to Detonation", which includes the "Precursor Shock in Solids" (pp 50-2) discussed in our write-up separately, and other items. Section IV contains a brief description of Gap Test (pp 56-8) and of Impact Test (pp 58-60)

Dunkle (Ref 5) stated that sensitivity can depend on crystal size especially in case of very sensitive expls. For example, LA in the form of very large crystals may explode spontaneously. This is thought to be due to the energy released in small areas when strain is relieved by fracture along a cleavage plane. This phenomenon serves to show that heat generated at spots during comminution may be sufficient to initiate an expln. The friction created by shearing or grinding may be simulated by a hardened weight swinging on a pendulum tangential to a surface on which is placed the expl, or, for less sensitive expls, by a hardened weight which slides down a trough at a definite but variable inclination to strike a glancing blow across a hardened surface on which is placed the explosive

Impurities, such as grit, shreds of cotton, even in small quantities, sensitize an expl to frictional impact. That is why utmost cleanliness must be exercised in the preparation of expls. There are differences in the sensitivity of azides to mechanical and thermal influences. They have been correlated with the structure of the outer electronic orbits, the electrochemical potential, the ionization energy and the arrangement of atoms within the crystal. Functions of the polarizability of the cation are the plastic deformability of the crystals, and their surface properties. The nature of cation in an azide, such as $Pb(N_3)_2$, has little effect on the energy released by the decomposition, which is vested in the N_3 ion. The high heat of formation of the N_2 molecule accounts

for the rather strong exothermicity. In contrast, the rate of the reaction depends very much on the nature of the cation. The nobler the metal is, the more easily the cation can pick up the electron from the azide ion and be reduced (Ref 5, p 145)

Under the title "Statistical Aspects of Sensitivity", Dunkle gives a résumé of a lecture presented by Mr A. Bulfinch at PicArns on 6 Jan, 1958 (Ref 5, pp 148-50)

The following sensitivity tests are listed or described in Vol I of this Encyclopedia:

Booster Sensitivity Test (p VIII) & PATR 1740, Rev 1 (1958)
 Detonation by Influence Tests (p X)
 Fire Resistance Tests (p XII)
 Friction Sensitivity Tests (pp XIII-XIV)
 Gap Tests (p XIV)
 Ignition Point Test (p XVI) & PATR 1740, Rev 1 (1958)
 Impact-Friction Pendulum Test (p XVII) and p A354, Note d
 Impact Sensitivity Tests (p XVII) & PATR 1740, Rev 1 (1958)
 Index of Inflammability (p XVII) & PATR 1740, Rev 1 (1958)
 Initiation Sensitivity by Electrostatic Discharge or by Sparks (XVIII)
 Sensitivity Tests (A list of various tests) (p XXII)
 Sensitivity to Flame, Heat, Sparks, Electrostatic Discharge, etc (pp XXII-XXIII) & PATR 1740, Rev 1 (1958)
 Wax Gap Test (p XXVI) & p A354, Note c

Following sensitivity tests are listed or described in Vol 2 of Encycl:
 Booster Sensitivity Test (p B247)
 Bullet Impact Test (pp B332 & B335 to B338)
 Bullet Test, French Method (pp 333 & B 339)
 No sensitivity tests are described in Vol III of Encycl, while in Vol IV, the tests are described under DETONATION (AND EXPLOSION), EXPERIMENTAL PROCEDURES and under DETONATION (AND EXPLOSION) BY INFLUENCE

The following German Sensitivity Tests are described in Ref 9: Beschussprobe (Rifle Bullet Test) (p Ger 11); Detonationsfähigkeit (Ability to Detonate) (pp Ger 34

& Ger 52); Detonationsübertragung (Detonation by Influence) (p Ger 34); Entzündungstemperaturprobe (Ignition Temperature Test) (p Ger 99); Verpuffungstemperaturprobe (Deflagration Temperature Test) (p Ger 215)
Refs: 1) E.H. Eyster et al, "The Sensitivity of High Explosives to Pure Shock", NOLM **10**, 366, 14 July, 1949 2) F.P. Bowden & A.D. Yoffe, "Initiation and Growth of Explosions", Cambridge Univ Press, London (1952) 3) F.P. Bowden et al, "Initiation and Growth of Explosions in Solids", Nature **180**, 73-75 (1957) 4) P.E. Skidmore & D.E. Thompson, "Development of an Improved Method for Determining the Impact Sensitivity of Liquid Explosives", ABL Rept **X-10**, Jan 1957 5) Dunkle's Syllabus (1957-1958), 145-48 (Sensitivities of Explosives) 6) Cook (1958), 38-141, 174, 178-97 & 331-35 (Sensitivity) 7) C.R. Grande, "New Method for Measurement of Relative Ignitability and Ignition Efficiency", PicArns FREL TechRept **2469** (Feb 1958) 8) F.P. Bowden, Pr-RoySoc **246A**, 145-297 (1958) 9) B.T. Fedoroff et al, PATR **2510** (1958) 10) H. Koenen et al, Explosivstoffe **6**, 178-89 (1958) 10a) Baum, Stanyukovich & Shekhter (1959), 22-80 (Chuvstvitel'nost' vzryvchatykh veshchestv) (Sensitivity of explosives) 11) S.D. Stein, "Quantitative Study of Parameters Affecting Bullet Sensitivity of Explosives", PA FREL TR **2636** (Sept 1959) 11a) Andreev & Belyaev (1960), 296-337 (Chuvstvitel'nost' vzryvchatykh veshchestv) (Sensitivity of expl substances) 12) Dunkle's Syllabus (1960-1961), pp 12a, 12d, 13a & 13f 13) A. Maček, ChemRevs **62**, 41-4 & 56-61 (1962) (140 refs) 14) C.M. Mason et al, "Sensitivity Characteristics of Liquid Explosive Systems", BuNavWeps, Contract **IPR 19-63-8029-WEPS**, ProgrRept No **7**, July-Sept 1963 15) A. Popolato, "Experimental Techniques Used at LASL to Evaluate Sensitivities of High Explosives", International Conf on Sensitivity and Hazards of Explosives", London, Oct 1963 16) F.C. Gibson et al, "Sensitivity Characteristics of Liquid Explosive Systems",

BuNavWeps, Contract **IPR 19-64-8026-WEPS**, ProgrRept No **1**, Jan-March 1964 17) J. Eadie, "The Effect of Wax on the Shock Sensitivity of Explosive Compacts", 4th-ONRSympDeton (1965), 399-403 18) J. Savitt et al, "Direct Contact Detonation Sensitivity", Ibid, pp 404-11 19) J.E. Hay et al, "The Effect of Physical and Chemical Properties on the Sensitivity of Liquid Explosives", Ibid, pp 412-25 20) Anon, "Military Explosives", TM 9-1300-214/TO 11A-1-34 (1967), pp 2-4, 5-1, 7-75, 7-79, 13-2 & 13-7

Detonation, Sensitivity to Initiation. See under Detonation (and Explosion), Initiation (Birth) and Propagation (Growth or Spread) in Explosive Substances

Detonation, Sensitivity to Shock. See "Detonation, Shock Sensitivity in"

Detonation, Shaped (Hollow or Cavity) Charge Effect. See under MUNROE-NEUMANN EFFECT AND LINED-CAVITY EFFECT

Detonation; Shock, Shock Effect, Shock Front, Shock Impulse, Shock Pressure, Shock Wave and Shock Zone, Definitions of.

According to the late Mr W.H. Rinkensbach (1894-1965), who worked as explosives chemist for many years at USBurMines and at Picatinny Arsenal [Davis (1943), p 431]:

"Shock and pressure are not synonyms. We can have a static gas under pressure; but there is no shock. There is no shock wave in the gas or shock effect on the wall of the container

Shock involves motion - that of a falling weight which impacts other matter, that of two railroad trains in collision or that of the highly compressed gases in a detonation which occupy the reaction zone back of the shock zone, which impacts the next monomolecular layer of undecomposed explosive. The velocity of such motion therefore is an important factor in the shock value of the phenomenon

The kinetic energy of a moving body is $E = \frac{1}{2}mv^2$, and I suggest that the shock effect might be calculated from this equation by using as m the mass of the matter in the reaction zone for a given explosive (calculated by hydrodynamic theory)

It should not be overlooked that an observed *shock effect* will be dependent upon the elastic limit value of the solid matter upon which impact is made by the matter of the reaction zone. Sand Tests made with Ottawa sand and with iron spheres of the same size should give very different results

But when the 'shock effect' is impinged on other matter, it is indicated by its shattering effect (brisance) - not by the total work effect of the explosive. This might be proved by making Sand Tests of Tetryl loaded at different densities. With different densities and consequent different rates of detonation, there should be different amounts of sand crushed"

Mr. C.G. Dunkle remarked that "a *detonation* is a true *shock pulse* but one in which the energy lost in attenuation is being replaced by the energy released in the chemical reaction associated with the detonation process" (Ref 13)

The difference between a *shock front* and a *shock zone* is explained in this write-up under "Detonation Front and Shock Front, Detonation Front and Detonation Zone" (See also Ref 4, pp 163-68 & Ref 10, p 14a) and under "Detonation, Shock Pressure in"

The difference between a *normal shock pulse* and the *shock front in a detonation* is explained under "Detonation (and Explosion), Initiation of Explosives and Shock Processes"

Initiation by *shock* or impact is discussed under "Detonation (and Explosion), Initiation in Explosive Substances"

Shock processes in the DDT are discussed under "Detonation (and Explosion), Development (Transition) from Burning (Combustion) or Deflagration" and also under "Detonation from Shock Transition" (See also "Shock Processes and Initiation", in Ref 4, p 194-96 and Ref 10, pp 17b & 17c)

Shock pressure is the pressure developed in the *shock front*, which is a very narrow layer also known as *shock zone*. The pressure reaches its peak of 230000 atm due to the shock

Shock effects are the most prominent of all the consequences of detonations and explosions and a *blast* is merely a *strong shock effect*

See also: "BLAST EFFECTS IN AIR, EARTH AND WATER" (Vol 2 of Encycl, pp B180-L to B184-R and the following items in this volume: "Detonation (and Explosion), Earthwaves from", "Detonation (and Explosion) Effects of Blast and Shock Waves on Structures", "Detonation (and Explosion, Effects Produced in Air, Earth and Water" and "DETONATION, SHOCK WAVES"

Refs: 1) J. vonNeumann & R.D. Richtmayer, "A Method for the Numerical Calculation of Hydrodynamic Shocks", JApplPhys **21**, 232-37 (1950) 1a) M. Sultanoff, "Detonation and Shock in Hollow Explosive Cylinder", 4thSympCombstn (1953), 494-97 & CA **49**, 6608 (1955) 2) M. Sultanoff & G.R. McVey, "Observation of the Shock From Spherical Pentolite Charges", BRL Rept **984** (1956) 3) G.R. Fowles, "Profile of an Explosive-Induced Plane Shock in Air", Poulter Labs, SRI Contract DA-04-200-ORD-294, TechRept **8** (Feb 1957) 4) Dunkle's Syllabus (1957-1958), 163-65, 194-96 and 292. Discussion by Dr R.C. Ling on *shock pulse* 5) V. Josephson, JApplPhys **29**, 30-2 (1958) (Production of high-velocity shocks) 6) Cook (1958), 322-52 (Shock waves in gaseous and condensed media) 7) J.O. Erkman, "Explosively Induced Nonuniform Oblique Shocks", PoulterLabsTechRept **010-58** (1958) 8) M.A. Cook et al, "Measurements of Detonation Shock and Impact Pressure", 3rd-SympDeton (1960), 357-85 9) J.L. Austing et al, "Strong Shocks in Porous Media", Ibid, 396-419 10) Dunkle's Syllabus (1960-1961), pp 14a & 17b-c 11) M.W. Evans & C.M. Ablow, ChemRevs **61**, 135-37 (1961) (The usual way of treating *shocks* is to idealize them to jump discontinuities, in this way taking into account the effect of

the irreversible processes caused by friction and heat conduction. It is assumed that the flow involving such a discontinuous process is completely determined by the three laws of conservation of mass, momentum and energy and the condition that the entropy does not decrease in the discontinuous process. Outside of the transition zone the flow is determined by the differential equations 2.1.1 & 2.1.3 for continuous flow, shown on p 131 of paper. There are two types of discontinuity surfaces, contact surfaces and shock fronts. There is no flow between regions separated by a contact surface; shock fronts are crossed by the flow. A contact surface moves with the fluid and separates two zones of different temperature and density, but the same pressure. The normal component of the flow velocity is the same on both sides of a contact discontinuity

The flow velocity relative to a shock is supersonic ahead and subsonic behind the shock. Thus, upstream characteristics behind the shock overtake it, while the shock itself overtakes the upstream characteristics ahead of it, as shown in Fig 5, reproduced here) 12) 4thONRSympDeton (1965), pp 205-345, 18 papers in the section entitled "Shock Waves and Related Flows", among them the paper of J.R. Rempel & D.N. Schmidt, "Shock Behavior of Some Non-Reacting Shocks", pp 266-76 (See also under DETONATION, SHOCK WAVES IN)

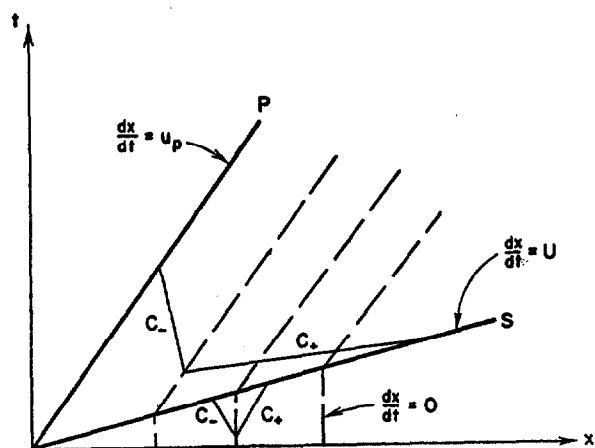

FIG 5 Flow in a steady, normal shock. Shock trajectory (S), piston path (P), sample forward characteristics (solid), and particle paths (dashed) are shown

13) G.G. Dunkle private communication, March 1968

Detonation, Shock Compressibility in.

Cook (Ref 2) devotes Chapter 9 to a discussion of compressive & elastic props of solids under expl attack. Modern applications of expls involve the compressibility of solids under extremely high pressures. Walsh et al (Ref 1) reported the equations of state of 27 metals under shock compression. Schall & Thomer (Ref 3) measured the shock compressibility of Mg-Al alloy, Lucite & polyethylene by flash radiographic techniques

See also Blast Effect (Vol 2, p 180ff), Detonation (and Explosion, Damage Caused by (Vol 3, p D3-L), and previous item on Shock Effect

Refs: 1) J.M. Walsh et al, "Shock-Wave Compressions of Twenty-Seven Metals. Equations of State of Metals", PhysRev **108**, 196(1957) 2) Cook (1958), p 206 3) R. Schall & G. Thomer, "Flash Radiographic Measurement of the Shock Compressibility of Magnesium Alloy, Lucite and Polyethylene", AirForceSpecialWeapon-Center, Rept AFSWC-TOR **62-134**(1962)

Detonation, Shock Hugoniot in. Boyle et al (Ref 5) reported that the current state of technology in the field of instrumentation does not lend itself to the direct measurement of the dynamics of pressure, particle velocity & density. However, these parameters can be inferred, for shocked expl chges, from the direct observations of shock velocity measured in inert monitor materials in direct contact with the expls. Boyle et al present shock Hugoniot data for several military expls and the experimental techniques used to obtain the data. The data, curves & equations extend the range of values (from elastic "sonic" values to the vonNeumann spike pressures) beyond those previously published, and they show good general agreement with previously published results

See Refs given below

See also Detonation, Chapman-Jouguet Parameters

Refs: 1) W.E. Deal, JApplPhys **28**, 782-84 (1957) (Shock Hugoniot of Air) 2) Dunkle's Syllabus (1957-1958), p 173, Fig 50a); Cook (1958, Shock Hugoniot is not listed as such, but "Hugoniot curve" is described on pp 61-2 3) M.W. Evans & C.M. Ablow, Chem-Revs **61**, 137(1961) (Under "Shocks") 4) T.P. Liddiard Jr, "The Unreacted Shock Hugoniots for TNT and Composition B", Internl Confer on Sensitivity and Hazards of Explosives, London, Oct (1963) 5) V.M. Boyle et al, "Determination of Shock Hugoniots for Several Condensed-Phase Explosives", 4thONRSympDeton (1965), 241-47 (12 refs) 6) N.L. Coleburn & T.P. Liddiard Jr, "Hugoniot Equations of State of Several Unreacted Explosives", JChemPhys **44**, 1929(1966)

Detonation, Shock Impedance and Acoustic Impedance in.

Acoustic impedance is the ratio between sound pressure and particle velocity. A sound wave, on reaching a boundary between two media, has part of its energy reflected at the boundary and part transmitted into the 2nd medium. The relationships depend on the values of the acoustic impedance in the two media. Swenson (Ref 2) showed that:

$$\frac{P_r}{P_i} = \frac{Z_2 - Z_1}{Z_2 + Z_1}$$

where P_i & P_r are the incident and reflected pressures respectively, and Z_1 & Z_2 the acoustic impedance; in the 1st and 2nd medium pedances in the 1st and 2nd medium

Shock impedance, $\rho_0 U$ (where ρ_0 is density and U shock velocity), defines similar relationships in shock waves. As a shock crosses a boundary into a 2nd material, a shock or rarefaction is reflected back into the 1st medium, depending on whether the shock impedance in the 2nd medium is greater or smaller than in the first. A similar equation, as for acoustic impedance, exists for shock impedance. If shock impedances in both media are the same (*impedance match*), no wave is reflected (Ref 3, pp 80-1)

As in the case of sound waves, pressure, p , and particle velocity, u , must match at the boundary. The amplitudes

and velocities of reflected and transmitted waves are determined by this "matching" requirement, and by P-u requirements for shocks and for rarefaction (Ref 1, pp 155-56)

Shock impedance of a material influences its action as a casing material for explosive charges. While pressures of detonation are sufficient to burst or deform any container, the duration of the detonation process is of the same order of magnitude as the expansion times of the usual containers. The rate at which the container expands is inversely related to the mass of container material which is moved. For a thin-walled container the mass is essentially that of the wall. For one having thick walls, the "effective mass" is proportional to $\rho_0 U$, because only the material which has been reached by the shock front is affected

In conclusion, Dunkle remarked that the shock impedance is a good measure of the effectiveness of a material as a confining medium for detonation (Ref 3, p 81)

Refs: 1) H. Eyring et al, "The Stability of Detonation", ChemRevs **45**, 69-178(1949) 2) G.W. Swenson, "Principles of Modern Acoustics", Van Nostrand, NY (1953) 3) Dunkle's Syllabus (1957-1958), 80-1

Detonation, Shock- or Impact-Loading of Metals, also known as Blast-Loading.

Rinehart & Pearson (Ref 1) have reported in detail the fundamental principles of fracturing metals under impact loading by HE's. Cook (Ref 1) devotes several pages to discussion of this subject. Both Rinehart & Pearson and Cook showed by high-speed photographic studies of the propagation of shock waves in transparent solids that such solids do not actually fail in compression except in the region of plastic deformation. These authors showed by means of plate indentation studies and measurements of velocities of small metal disks placed on the end of a massive target opposite the expl chge that the shock pulse transmitted from the end of a cylinder has the shape at close range resembling the theoretical detonation head (qv). Apparently the deton head pulse passes into the

metal with very little initial change in form

See also Detonation, Spalling and Scabbing of Solids in

Refs: 1) J.S. Reinhart & J. Pearson, "Behavior of Metals under Impulse Loads", AmerSocMetals, Cleveland, Ohio (1954)
2) Cook (1958), pp 341ff 3) I. Jaffe et al, "Behavior of Plexiglas under Shock-Loading by a Tetryl Donor", NOLTR 64-66 (1964)

Detonation, Shock-Pass-Heat-Filter (SPHF) in Investigation of. See Ref 40 under DETONATION (AND EXPLOSION), EXPERIMENTAL PROCEDURES and in the following refs:

Refs: 1) Cook (1958), 83-9 & 187-94
2) M.A. Cook et al, JApplPhys 30, 1579-84 (1959)

Detonation, Shock Pressure in and Its Measurements. A brief definition of shock pressure is given under Detonation, Shock, Shock Effect, etc. Besides shock pressure, known also as *spike pressure*, there is also the pressure at the end of the *reaction zone* (See Detonation, Reaction Zone in). The latter pressure is known as Chapman-Jouguet Pressure or C-J Detonation. It is explained under "Detonation, Chapman-Jouguet Parameters" and also under "Detonation (and Explosion) in Condensed Explosives"

The pressure "jump" necessary to initiate detonation in various expls does not belong under this heading. This has been discussed under "Detonation (and Explosion), Initiation - - - in Explosive Substances". The actual value of the required "jump" seems to be 25-50 atm (Ref 9). It can be measured by the method described in Ref 8

By classical C-J theory, the "spike pressure" is twice the C-J pressure, but some scientists think that it is not as high; Cook's school thinks that the spike pressure is very little, if at all, higher than the C-J pressure (Ref 5, pp 68-9 & 79-80; Ref 2, p 175; Ref 7, p 14f; & Ref 8)

Shock pressures can be measured by the same methods as detonation pressures are determined (Ref 1) and also by the methods described under "DETONATION

(AND EXPLOSION), EXPERIMENTAL PROCEDURES". Determination of shock pressure required to initiate detonation of an acceptor in the shock sensitivity test is described in Ref 8

Refs: 1) W.C. Holton, "The Detonation Pressure in Explosives as Measured by Transmitted Shocks in Water", NavOrdRept 3968 (1954) (Conf) 2) Dunkle's Syllabus (1957-1958), p 175 3) Cook (1958), 68-9 & 79-80 4) A.B. Amster & R.L. Beau regard, "Pressure Sensing Probes for Detecting Shock Waves", RevSciInstrs 30, 942 (1959) 5) M.A. Cook et al, "Measurements of Detonation Shock and Impact Pressure", 3rdONRSympDeton (1960), 357-85 6) J.L. Austing et al, "Strong Shocks in Porous Medium", Ibid, 396-419 7) Dunkle's Syllabus (1960-1961), p 14f 8) I. Jaffe et al, AmRocketSocJ 32, 22-5 (1962) & CA 56, 11872 (1962) (Determination of shock pressure required to initiate detonation of an acceptor in the shock sensitivity test) 9) C.G. Dunkle, private communication, March 1968

Detonation, Shock Propagation in. The development of a shock wave which initiates heat release by chemical reaction is an important problem in detonation studies. A number of investigators have obt'd solutions by the step-by-step numerical integration of the partial differential equations governing the flow behind the shock (Ref 2). The "initial" shock wave in air from a detonation has only a very short life, being superseded by a more energetic one after propagating only a few diameters from the chge. The wave that finally emerges from the gas cloud is quite different from the initial shock; it has a lower peak pressure, is much broader and more energetic. The initial wave is the **shock wave** and the latter is the pressure wave (Ref 1). Adams & Cowperthwaite (Ref 2) examined the growth of a plane shock generated by a constant velocity piston moving into a material where heat was generated behind the front at a constant rate, and they describe a general method for solving such one-dimensional

reactive shock problems

Refs: 1) Cook (1958), 322ff 2) G.K. Adams & M. Cowperthwaite, "Explicit Solutions for Unsteady Shock Propagation in Chemically Reacting Media", 4th ONR Symp Deton (1965), 502-11

Detonation, Shock Regime Thermoelectric Effect in.

When a shock wave crosses the junction surface of two different metals, there appears between the uncompressed extremities of the metals a difference in potential, the magnitude of which is dependent on the amplitude of the shock wave & the nature of the metals. This effect had been first noted in 1959 during the investigation of a thermal elec detector for the recording of temp at the shock front. The adiabatic compression of the metal in the shock gives rise to an increase in temp. The experimental study of the electrical response of thermocouples made with different metals, when put into shock loaded metallic samples, showed that a) they behave like static thermocouples and b) the response seems to increase with pressure up to 1600 kilobars and is of such magnitude that any classical interpretation appears impossible (Ref)

Ref: J. Crosnier et al, "Anomalous Thermoelectric Effect in the Shock Regime and Application to a Shock Pressure Transducer", 4th ONR Symp Deton (1965), 627-38

Detonation, Shock Sensitivity in. Sensitivity to shock of explosives, which might also be called "detonability by shock", has been recently measured, mostly by gap tests, using instead of air some plastic materials (such as Lucite) or cardboard for the gap. Some of these tests are described under "DETONATION (AND EXPLOSION), EXPERIMENTAL PROCEDURES IN" and also under "DETONATION (AND EXPLOSION), INITIATION BY SHOCK" (See also under Detonation, Sensitivity of Explosives to)

Addnl Refs: A) M.A. Cook & L.L. Udy, "Calibration of the Card-Gap Test", ARS-J 31, 52-7 (1961) B) Donna Price & Irving

Jaffe, "Large Scale Gap Test: Interpretation of Results for Propellants", ARS-J 31, 595-96 (1961) C) I. Jaffe, R. Beau regard & A. Amster, "Determination of the Shock Pressure Required to Initiate Detonation of an Acceptor in the Shock Sensitivity Test", ARS-J 32, 22-5 (1962) D) J. Toscano, I. Jaffe & G. Robertson, "Large Scale Sensitivity Test: Comparison of Tetryl and Pentolite Donors", AIAA-J 1, 964-66 (1963) E) M.C. Chick, "The Effect of Interstitial Gas on the Shock Sensitivity of Low Density Compacts", 4th ONR Symp Deton (1965), 349-58

Detonation from Shock, Transition to.

The growth of detonation from shock in solid explosives was examined by several investigators. For example, Jacobs et al (Ref 1) examined it for TNT and three Cyclotols using initial pressures ranging from 30 to 140 kbars. The build-up to detonation of Cyclotols was sensitive to the RDX particle size and occurred more rapidly in pressed than in cast charges. In pressed chges of TNT, the *shock velocity* could temporarily exceed the normal detonation value during the build-up before decaying to the normal detonation rate. In cast chges of TNT, an intermediate velocity betw that of the initial shock and the normal deton rate was observed before growth to the normal deton rate

Cook & Gwyther (Ref 2) determined the influence of axial electrical fields on shock of detonation transition. Study was conducted by means of the DDT (deflagration-to-detonation transition) in a modified card gap test or SPHF (Shock-Pass-Heat-Filter) plate test by observing the influence of an applied field on the distance S_2 into the receptor where the DDT occurs. Tests have shown that the value S_2 for Composition B is appreciably influenced by an applied electrical field. The magnitude of the effect in 2-inch diam cast Compn B (donor and receptor) and a 5-cm Lucite SPHF plate was ca 0.15 mm/kv/cm, a positive to negative potential increasing the distance S_2 , and a negative to positive one decreasing S_2 (unless the DDT occurs too close to an electrode)

Refs: 1) S.J. Jacobs et al, "The Shock-to-Detonation Transition in Solid Explosives", 9thSympCombstn (1963), 517-26 & CA 59, 11180(1963) 2) M.A. Cook & T.Z. Gwyther, NASA Accession No N66-23949 Rept No AD629239. Avail CFSTI, \$3.00, 15 pp (1965); SciTechAerospace Rept 4(13), 2472(1966); CA 66, 9117(1967)

Detonation, Shock Transmission from Explosive to Metal Plate. Accd to Cook (Ref 3, p 111), R.W. Goranson is credited with suggesting that it is possible to determine the $p(x)$, $W(x)$ and $\rho(x)$ distribution in the detonation wave by studying the characteristics of the shock wave transmitted from the explosive into a thin metal plate in shock loading of the plate by a detonation wave. In this theory, when a plane detonation wave strikes a metal plate at normal incidence, a shock wave is transmitted into the plate and another is reflected back into the incident wave such as to give a pressure-distance profile like that illustrated in Fig 5.17 [reproduced by Cook from the paper of Walsh & Christian (Ref 1)].

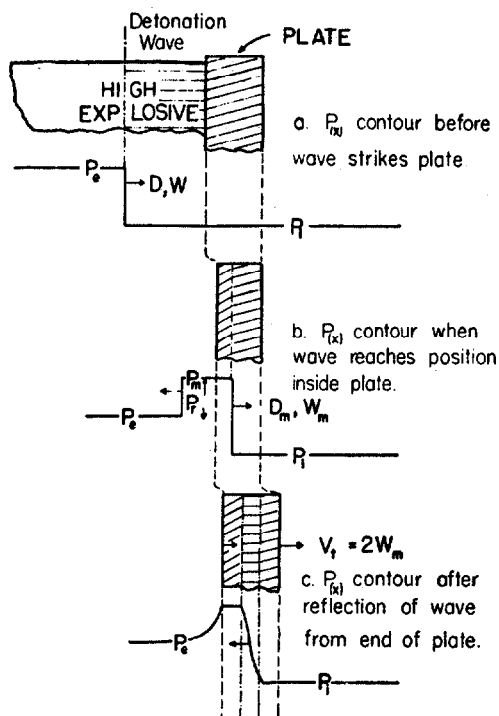

Figure 5.17. Shock transmission from explosive to metal plate (after Walsh and Christian)

The transmitted wave has a shock velocity D_m and a particle velocity W_m related thru conservation laws to velocity D and particle velocity W in the explosive. Upon reaching the *free surface* of the metal the shock is reflected as a rarefaction wave and the free surface acquires a velocity V_f of approx twice W_m . Hence, the measurement of V_f and D_m gives a means of determining W_m and pressure of shock p_m thru the equations:

$$P_m = \rho_{1m} D_m W_m \quad (5.22)$$

$$V_f = 2W_m \quad (5.23)$$

Moreover by applying boundary conditions:

$$(P + P_r) = P_m \quad \text{and} \quad W_r = W - W_m$$

as indicated in Fig 5.17, it is possible to compute the $W(x)$ and $p(x)$ characteristics from measured free surface velocity versus plate thickness $[V_f(t)]$ data using eq 5.23 and the relation:

$$\rho_1 D W + \rho_{1r} D_r (W - W_m) = \rho_{1m} D_m W_m$$

If $\rho_{1m} D_r$ is taken, in approximation, as equal to $\rho_1 D$, the following equation may be deduced:

$$W_m / W = V_f / 2W = 2\rho_1 D (\rho_1 D + \rho_{1m} D_m) \quad (5.24)$$

Here subscript 1 refers to original explosive; subscript m refers to the transmitted wave, r to the reflected wave and no subscript applies to the incident wave. In the steady state D is constant, which permits one to measure $W(x)$ directly thru the above equations. Also the ratio p_m / p_2 may be obt'd from a relation given by Deal² (Ref 2), from which equation 5.25 is obtained:

$$P = P_m (\rho_{1m} D_m + \rho_1 D) / 2\rho_{1m} D_m \quad (5.25)$$

This equation makes possible the detn of C-J pressure p_2 by extrapolation to zero-plate thickness in cases where reaction-zone length a_0 is negligible. Deal assumed, furthermore, that this extrapolation should give p_2 even where a_0 is appreciable by an extrapolation which ignores the spike (Ref 3, pp 111-14)

In the discussion on p 115, Cook lists two more equations:

$$2p(x) = p_2 W'_m / W_2 + P_m \quad (5.26)$$

and, for $p(x) = p_2$:

$$p_2 = P'_m (2 - W'_m / W) \quad (5.27)$$

where W'_m and p'_m correspond to the characteristics W_2 and p_2 of the detonation wave, i.e., the beginning of the spike or, if the spike is ignored as in the study of Deal, to the extrapolated (zero thickness) value of free surface velocity (or W') for explosives of negligible reaction-zone length

On p 116 Cook gives a table listing characteristics obt'd by Deal for several expls using Dural plates ($\rho_{1m} = 2.792 \text{ g/cm}^3$)

Table

| Characteristics | TNT | Comp B | 75/25 Cyclotol | RDX |
|---------------------------------------|--------|--------|----------------|--------|
| ρ_1 (g/cc) | 1.64 | 1.712 | 1.743 | 1.762 |
| W'_m (mm/ μ sec) | 1.169 | 1.6945 | 1.767 | 1.792 |
| p'_m (megabars)(from equation 5.22) | 0.2244 | 0.3562 | 0.3753 | 0.3817 |
| p_2 (megabars)(from equation 5.26) | 0.178 | 0.293 | 0.313 | 0.235 |

Deal's values of p_2 for Comp B are higher than computed results (0.233 megabars) by the hydrodynamic theory of detonation (Ref 3, p 116)

Refs: 1) J.M. Walsh & R.H. Christian, PhysRev **97**, 1544 (1955) 2) W.E. Deal Jr, 2ndONRSympDeton (1955), pp 209-24 (The Measurement of Chapman-Jouguet Pressures for Explosives) 3) Cook (1958), pp 111-15

Detonation, Shock Tube Technique Studies in.

A shock tube is a device for producing shock waves. Accdg to Dunkle (Ref 5, p 6) one of the simplest means of producing shock waves is to push the air along inside a long, narrow tube (known as the *shock tube*) by a piston moving at supersonic speed. This will force the air ahead to move at the same rate. The air will continually accumulate ahead of the piston so as to form a front which moves ahead at an even faster rate, for as the air moves it is capturing material ahead of it. This front, which is an abrupt *discontinuity*, is called a "shock front". When the piston stops, the air ahead of it, which has previously been set in motion at high velocity, will continue to move thru inertia

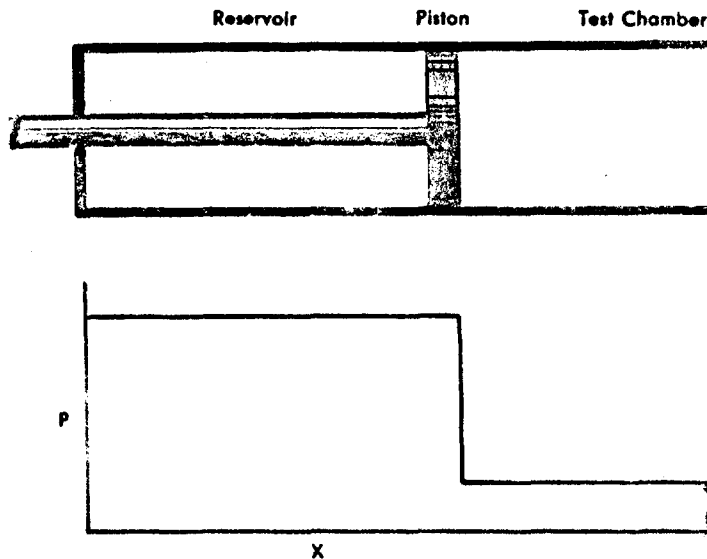

FIG 1 SHOCK TUBE REPRESENTATION

Up to this time, the pressure thruout the region from the piston to the advancing front remains constant. Even after the piston is stopped the front continues to advance at its previous supersonic velocity and the pressure remains at this constant value for a considerable distance behind the front. However, the movement away of the material immediately ahead of the piston creates a *rarefaction*, for there is nothing to take the place of removed air. The pressure within this rarefaction zone will fall below the original pressure and will even approach a vacuum in some cases. While the shock front continues to advance, the rarefaction wave follows some distance behind. It has been shown that in an inert medium, such a rarefaction wave will always advance faster than the original shock front and is bound to overtake

it eventually. The shock front, however, continues to move at constant speed until the rarefaction wave catches up with it. As soon as this happens the peak pressure starts to fall. As the pressure discontinuity drops to zero the disturbance slows down to the speed of sound, rounds off, and becomes an ordinary acoustic wave. There is no one speed for shock waves and the sharper this pressure discontinuity, the faster they go (Ref 5, p 7)

Morrison (Ref 1, pp 38-42) described a shock tube (See Fig 1) containing inside a piston which separates two gases of two different states. One section of the tube is closed from the outside forming a reservoir. Assuming that the gas to the left of piston is at a higher pressure than the gas to the right of it, let the piston (starting

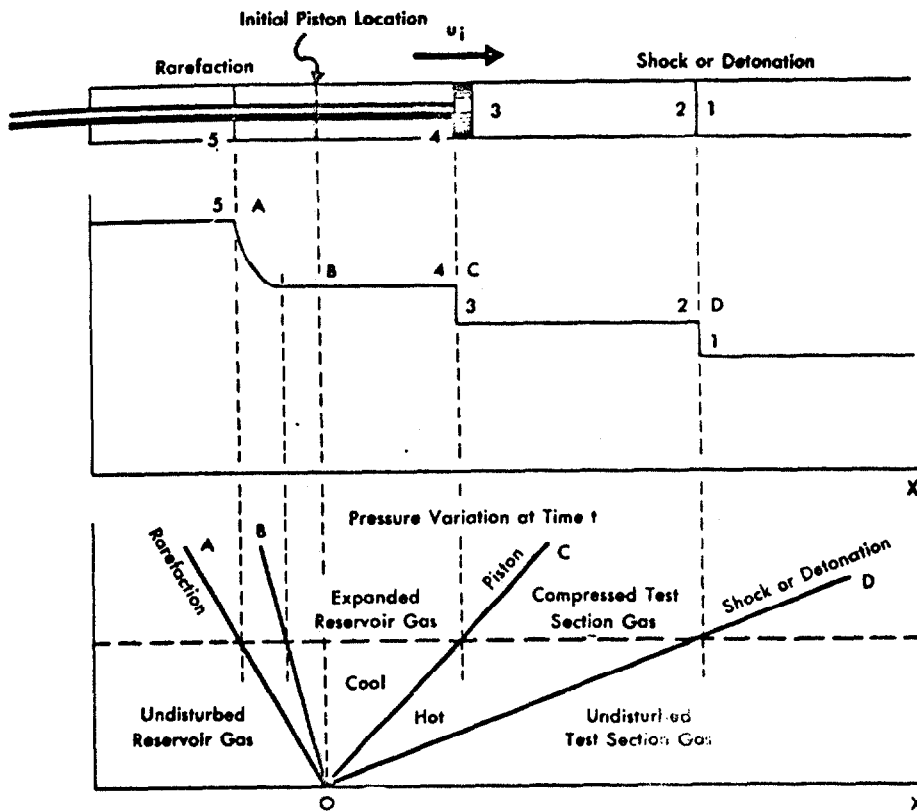

FIG 2 TIME-DISTANCE PLOT SHOWING THE LOCATION OF THE RAREFACTION WAVE, PISTON, AND SHOCK WAVE

from rest at $X=0$) be accelerated instantaneously to the right of 0 up to some constant velocity U_i . As a result of this a *shock wave* or a *detonation wave* will develop at the front face of the piston and travel to the right at *supersonic* speed. A *rarefaction wave* will be formed at the rear face of the piston and move to the left with *sonic* speed. This situation is schematically shown in Fig 2

The flow process may then be broken into two problems: 1) a study of the flow to the right of piston and 2) a study of the flow to the left of the piston

If the piston is replaced by a diaphragm and the diaphragm is ruptured, the problems would be analogous; the only difference being that the pressures and velocities are continuous across the piston

Assume, as in Fig 2, a piston starting from rest at $X=0$ and immediately accelerated to a velocity u_i . Later at time t , the piston is at some position x_i . Conservation relations may be written for the gas contained betw the piston and some moving boundary at position x_t and traveling at a velocity u_t , where subscript t denotes transmitted conditions. The relations are:

$$\text{Conservation of mass: } \frac{d}{dt} \int_{x_i}^{x_t} \rho dx = \rho_1 u_t \quad (3.1)$$

$$\text{Conservation of momentum: } \frac{d}{dt} \int_{x_i}^{x_t} \rho u dx = P_2 - P_1 \quad (3.2)$$

$$\text{Conservation of energy: } \frac{d}{dt} \int_{x_i}^{x_t} \rho \left(e + \frac{u^2}{2} \right) dx = \frac{dQ}{dt} + P_2 u_2 + \rho_1 u_t + \left(e^2 + \frac{u_2^2}{2} \right) \quad (3.3)$$

where: ρ = density
 u = velocity
 P = pressure
 e = internal energy per unit mass, and
 Q = heat added to the system contained betw $x_i < x < x_t$

By use of Leibnitz rule, equations 3.1, 3.2 & 3.3 may be reduced to eqs 3.4, 3.5 & 3.6 of Morrison's paper (which are not shown here)

For cases where the time derivatives of the above equations vanish and where u_t is

regarded as a shock or detonation velocity and x_t as the position of the shock or detonation wave at time t , these equations may be simplified to:

$$\frac{\rho_1}{\rho_2} = \frac{u_t - u_i}{u_t} \quad (3.7)$$

$$\rho_2 u_t (u_t - u_i) = P_2 - P_1 \quad (3.8)$$

$$\frac{\rho_1}{\rho_2} = \frac{u_t - u_i}{u_t} \quad (3.9)$$

Since eq (3.9) is identical with eq (3.7), there is no necessity to introduce the energy equation to the problem of shocks

Combining eqs (3.7) & (3.8) we obtain:

$$P_2 - P_1 = \rho_1 u_t u_i \quad (3.10)$$

which is a very useful equation connecting the pressure difference across a discontinuity with the velocity of discontinuity and the velocity of gas behind it. Eq (3.10) is applicable to detonations, explosions, deflagrations and shocks (Ref 1, pp 38-42)

Dunkle (Ref 10, p 74) described the shock tube with diaphragm as a long tube, usually closed at both ends, which contains in the compartment at one side of the diaphragm (the chamber) gas at high pressure (driver), while at the other side (the chamber) is gas at low pressure (reactant). Usually the two are in thermal equilibrium. When the diaphragm is ruptured the driver gas expands instantaneously from the chamber into the channel. This action generates a shock wave that propagates ahead of the contact surface of contact front into the reactant gas causing its heating and compression. At the same time a centered rarefaction wave is propagated into the chamber

The shock-tube theory discussed by Dunkle on pp 74-6 of Ref 10 is not given here because it seems that Morrison's discussion described above gives a basic idea

The above discussion dealt with application of shock tubes for inert media, but they can also be used for the study of high temperature reactions, as well as for deflagrations, explosions and detonations

The shock tube was first utilized in France by P. Vieille (1854-1934) in 1890 for flame propagation experiments. Then the application was spread to other countries

and in the U.S. the device was considerably improved during WWII by W. Payman & W.C.F. Shepherd. Since 1940 it has come into widespread use as a tool for gas dynamic research by Universities and Ordnance Laboratories (Ref 10, p 74)

Fig 3 shows shock tube with a diaphragm and charging equipment such as used by Morrison (Ref 1, p 74) at Univ of Michigan for most of the velocity runs. The principal part of the equipment consisted of a half inch extra-strong commercial pipe. The reservoir and test chamber sections were con-

nected by means of a pipe union which was machined to receive diaphragms, and also to provide a constant cross-sectional shape and area. Detail of diaphragm assembly is shown in Fig 4

When the tube was operated as a shock tube (i.e. when detonation was initiated from a shock), a diaphragm of cellophane or photographic film was inserted in the union along with an O-ring to seal the test chamber. To burst the diaphragm compressed He or H was fed into the reservoir section until rupture occurred. The burst pressure was read from

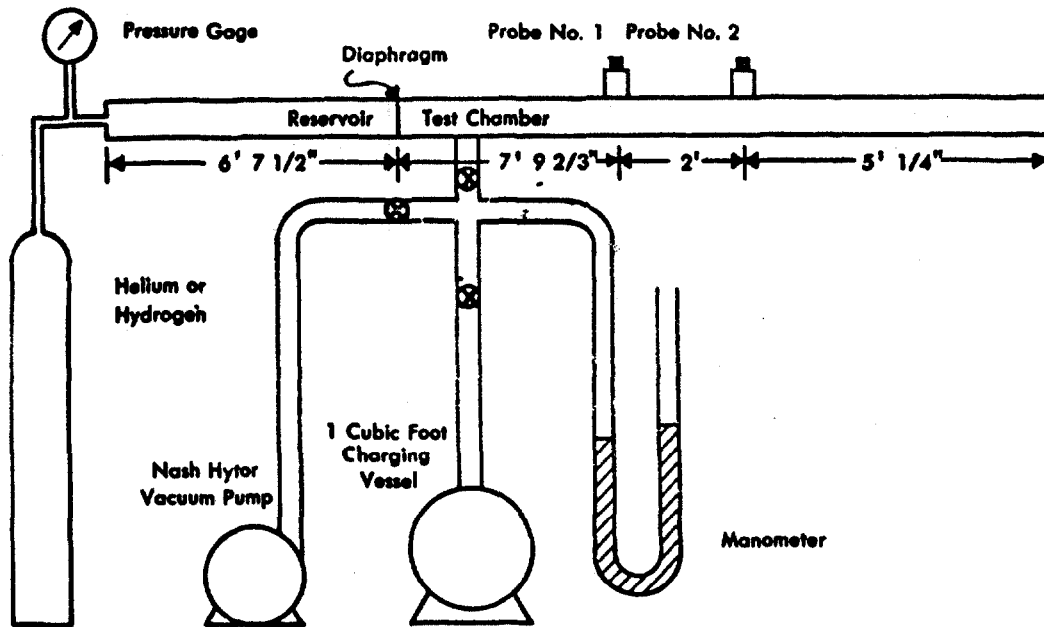

FIG. 3 SHOCK TUBE AND CHARGING EQUIPMENT

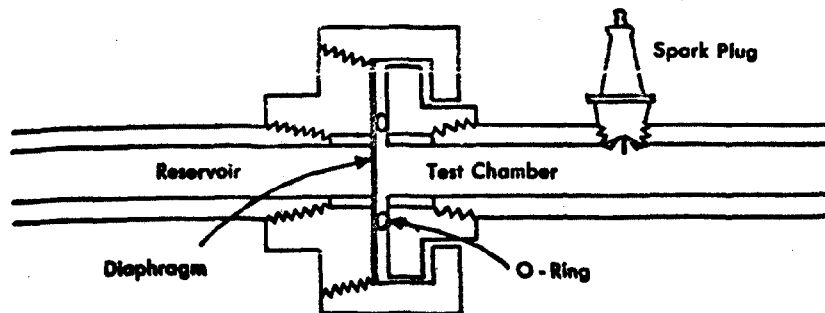

FIG 4 DIAPHRAGM ASSEMBLY

a calibrated standard Bourdon tube pressure gage. For runs in which the shock tube was used as a flame tube (i.e. when the detonation was induced by a flame propagating down the tube and not by a shock), a metal diaphragm was placed in the union. Ignition of the charge was secured from a miniature spark plug located just down-stream from the diaphragm. A commercial 6000-volt neon transformer was the current source for the plug. Fuels and oxidants were premixed in two one-cubic-foot spheres (See Fig 3) and either or both spheres were used as needed. To change the spheres, they were first evacuated to a pressure of ca 1 inch Hg absolute, filled with fuel, evacuated again, and then refilled with fuel to predetermined pressure. Oxygen or air was then added to a new predetermined pressure, the mixture ratio being determined by the ratio of partial pressures. The sphere was provided with a 3-inch blow out diaphragm as a safety precaution.

Velocities of detonation were found by recording the time it took for a wave to pass between two points in the tube at a known distance apart. Since the deton wave of the gases traveled at velocities up to 12000 ft/sec, a timer that recorded intervals as small as 75 μ secs was necessary if distances between probes were to be 1-2 ft. No known commercial timer of these capabilities was found, therefore one was designed & fabricated by Morrison (Ref 1). It was appropriately calibrated.

Several different probes were experimented with before a suitably sensitive & reliable one was found. It worked by the ionization of the detonated gases. The photographing of the deton waves was possible by use of spark photograph with shadowgraph or schlieren systems.

Nicholls et al (Ref 2) extended Morrison's investigation directing it toward a photographic study of deton waves in nonuniform ducts. They also investigated the limits of deton of gases which possess suitable properties for the possible achievement of a standing deton wave. A few photographs were taken with a small rectangular tube used as a "flame tube". In these tests the film diaphragm was left out and the entire tube filled with a test gas.

Deton was then achieved by the use of an automatic-type spark plug near the upstream end of the tube. The plug was located ca 4.3 feet from the test section and it was felt that the deton would be fully stabilized by the time it reached the test section. Detailed description of techniques used in these studies is given on pp 8-35 of Ref 2.

Under the title "shock-tube limitation", Dunkle stated (Ref 10, pp 79-80) that the inherent shortcoming of the shock tube is the very short testing time, although some increase of the time is possible with lengthening of the tube. In any test the tube must be long if strong shock waves are desired. This is because at any station the testing time or time interval between the arrival of the shock front and of the contact surface (which is in reality a mixing zone between "driver" and "reactant"), decreases with increase in Mach number. Nevertheless, the increase in testing time so obtained is limited because of the appreciable attenuation of the wave in traversing a tube many diameters long. Thus as the tube becomes longer, the difficulty of obtaining the desired shock strength at the test station grows. Furthermore, the growth of the boundary layer of the tube causes a variation with time of the flow properties behind the wave, thus limiting the tube's usefulness. Its diameter must be as large as practicable to alleviate this problem. A conventional shock tube subjects the reactant gas to repeated reflections of pressure waves and rarefactions which limit its value for chemical kinetics investigations. A modification designed by Glick et al (Ref 4a) avoids this complication by producing a single high-temperature pulse. Blackman (Ref 7a, p 61) developed a convergent channel of area ratio 34:1 to produce strong shock waves, while Jones (Ref 9a) obtained high flow Mach numbers by expanding the flow through a nozzle (Ref 10, p 80).

More recent modifications of shock tubes are briefly discussed in papers given in the book edited by Stoops (Ref 21).

A. Kantrowitz in the paper entitled "Shock Tubes for High Temperature Gas Kinetics", given on pp 241-88 of that book stated that:

The essential advantage of shock tubes over electric discharge devices is the capability of producing a homogeneous gas sample (HGS) with enthalpy and pressure which can be dependably calculated from the measured shock velocity and the conservation laws. The advent of electromagnetically driven shock tubes opens up the possibility of achieving similar advantages at temperatures up to millions of degrees

Using high pressure ratios across the diaphragm combined with large ratios of driver-to-reagent speed of sound permitted attainment of very high temps, e.g. 18000°K, while retaining many of the advantages of the electromagnetic shock tube. Moving plasmas produced by acceleration by electromagnetic forces could be used to drive very high-speed shock waves. To accomplish this and produce an HGS calculated from the conservation law, it is necessary that the driver gas electromagnetically shield the reagent gas from the heating and disturbing effects of the driver currents. Satisfaction of this requirement is feasible for a 1-meter shock tube in H₂ at temperatures over 20000°K, but apparently is established only by Patrick's Magnetic Annular Shock Tube (MAST) experiments. At temperatures above a few electron volts, increases in diffusion speed necessitate the use of containing magnetic fields. There is evidence that he has produced shock velocities up to 600 mm/μsec and an HGS with enthalpy corresponding, after equilibrium, to temperatures above 10⁶ °K

The extension of the shock tube to the plasma region where particle collisions become infrequent and other dissipative mechanisms must be explored, opens an exciting area for study

In the discussion of the same paper (pp 286-8) M. Norrish suggested generation of shock waves by adiabatic heating of an isolated section of a gas sample by flash irradiation. Thus a H₂/O₂ mixture with a trace of NO₂ as a sensitizer (and no added coolant gas) could be subjected to a high-intensity flash at one end of a quartz tube, the rest of the tube (to the extent of possibly 5/6) being blacked out. In such a detonation, Thrush (Ref 8a) has observed the emission

resulting from the sharp thermal compression. A sharp emission peak produced when the shock wave hits the end of the reaction vessel lasts 1-2 μsec. Work on knock and anti-knocks has shown, with amyl nitrite etc used as sensitizer, that *knock in the internal combustion engine* is identical with homogeneous detonation and that when an anti-knock, such as PbEt₄, is added to the mixture, the sharp peak of emission is smoothed out to a curve characteristic of slower burning and the suppression of detonation

On pp 289-310 (Ref 21), A.G. Gaydon, "Shock-Tube Studies of Processes of Electronic Excitation in Gases" reported that the spectrum-line reversal temperature in shock-heated gases can be used to obtain information about efficiencies and processes of electronic excitation of metal atoms at high temperatures. For excitation by molecules, the electronic excitation temperature tends to follow the effective vibrational temperature of the molecules, and reversal temperatures may be low near the shock front if the vibrational relaxation time is appreciable. Although excitation of metal atoms by cold inert gases has a very small effective cross-section, it is shown that at 2500°K the cross-sections of excitation of Cr or Na by Ar or Ne are around 1/20 of the gas-kinetic cross-sections

In complete equilibrium, the ratio of the population of an atomic or molecular species in an excited electronic state to the population in the ground state is given by Boltzmann factor $e^{-E/kT}$ and the statistical weight term. Under these equilibrium conditions the process of electronic excitation by absorption of radiation will be in balance with electronic deactivation by emission of radiation, and collision activation will be balanced by collision deactivation; excitation by chemical reaction will be balanced by the reverse reaction in which the electronically excited species supplies the excitation energy. However, this perfect equilibrium is attained only in a constant-temperature inclosure such as the ideal black-body furnace, and the radiation must then give a continuous spectrum with unit emissivity. In practice we are more familiar with hot gases emitting dis-

crete spectra, often with rather low emissivity. Under these conditions, depopulation of excited electronic states by emission of radiation must exceed the rate of population by absorption, so that the proportion of atoms or molecules in excited electronic states tends to fall below the Boltzmann equilibrium value. The extent to which it falls below depends on the extent to which the collision processes can maintain the population, i.e., on the relative importance of the radiation and the collision processes

Reversal-temperature measurements of the Na and Cr lines in simple molecular gases, shock-heated to 2000-3000°K and to 0.2-2 atmospheres agree excellently with temperatures calculated from the measured shock velocity. Thus in these cases, collision processes are rapid enough to maintain effective equilibrium between ground and excited state populations despite radiation losses. In some shock tube work, however, the reversal temperature is initially above the equilibrium value, probably owing to delay in dissociation of the molecules, so that the temperature in translation and in internal degrees of freedom of the molecules is initially too high

For some molecules, especially N₂ and CO, the temperature is low close to the front and rises fairly quickly toward the equilibrium value, apparently owing to the delay of the molecules in taking up vibrational energy, and indeed the time agrees well with other measurements of the vibrational relaxation times interpolated to the temperature and pressure conditions within the shock

It has been realized for many years that interchange of electronic and vibrational energy is more probable than interchange of electronic and translational energy. However, it still seems very inefficient except for a near coincidence of vibrational and electronic energy levels. The ultra-simplified theory seems inadequate (Ref 34)

Refs: 1) R.B. Morrison, "A Shock Tube Investigation of Detonative Combustion", Univ of Michigan, Willow Run Res Center, UMM-97 (Jan 1952) [Contract AF 33(038) 12657] 2) J.A. Nicholls et al, "Final Report

on Detonative Combustion", Univ of Mich Proj M898 (1953) [Contract No. AF 33(038)-12657] 3) I. Glass & N. Patterson, "Shock Tube Flows", *JAeronauticalSciences* **22**, 73-100(1955) 4) A.E. Wolfe, "Shock Tube for Gage-Performance Studies", *JPL CalTech- Rept 20-87* (May 1955) 4a) H.S. Glick et al, "A New Shock Tube Technique for the Study of High Temperature Gas Phase Reactions", *5thSympCombstn* (1955), 393-402 5) C.G. Dunkle, "Introduction to Theory of Detonation of Explosives", Lecture Delivered at Picatinny Arsenal, Dec 13, 1955, p 6 (Shock tube technique) 6) R.N. Hollyer, Jr, "Attenuation in a Shock Tube: I Laminar Flow", *JApplPhys* **27**, 254-61 (1956) 7) F.T. Harris & J. Guarrami, "Shock Tube Generates Waves of Known Intensity", *DOFL* (Diamond Ordnance Fuze Laboratory), Feb 1956, pp 10-12 7a) V. Blackman, "Vibrational Relaxation in Oxygen and Nitrogen", *JFluidMech* **1** (1), 61-85 (May 1956) 8) A. Herzberg, "The Application of the Shock Tube to the Study of the Problems of Hypersonic Flight", *JetPropulsion* **26**, 549-55 (July 1956) 8a) B.A. Thrush, *PrRoySoc* **233A**, 147-51 (1956) (See under discussion of papers given in the book edited by Stoops and listed here as Ref 21) 9) R.F. Chisnell, "Motion of a Shock Wave in a Channel with Application of Cylindrical and Spherical Shock Waves", *JFluidMech* **2-3**, 296-98 (May 1957) 9a) J.J. Jones, "Experimental Investigation of Attenuation of Strong Shock Waves in a Shock Tube with Hydrogen and Helium as Driver Gases", *Langley Aeronautical Field, NACA TN 4072*, (July 1957) 10) Dunkle's Syllabus (1957-58), 74-7 (Shock tube theory); 79 (Shock tube limitations), 123-26 (Shock tube studies in detonation by various investigators) 11) S.J. Emrich & D.B. Wheeler, Jr, "Wall Effects in Shock Tube Flow", *PhysFluids* **1**, 14-23 (Jan-Feb 1958) 12) R.A. Alpher & D.R. White, "Flow in Shock Tubes with Area Change at the Diaphragm Section", *JFluidMech* **3**(5), 457-90 (1958) 13) I. Ginsburgh, "Abnormally High Pressure in a Shock Tube", *JApplPhys* **29**, 1381-82 (1958) 14) M. Summerfield & R.F. McAlevy III, "The Shock Tube as a Tool for Solid Propellant Ignition Research", *JetPropulsion* **28**, 478-81 (July 1958) 15) W.H. Christiansen,

"Use of Fine Unheated Wires for Heat Transfer Measurements in the Shock Tube", GAL CIT Hypersonic Research Memorandum No. 55, (June 1960) 16) Dunkle's Syllabus (1960-1961), pp 7c to 7e (Shock tube limitations) 17) W.J. Hooker, "Testing Time and Contact Zone Phenomena in Shock Tube Flows", Physics of Fluids 4, 1451-63 (Dec 1961) 18) G. Rudinger, "Effect of Boundary-Layer Growth in a Shock Tube on Shock Reflection from Closed End", Ibid, 1463-73 19) R. Nantu Teng, "Investigation of Spherical Shock Waves in a Shock Tube", MIT (Massachusetts Institute of Technology) FluidDynamicsResearchLaboratory Contract No AF 19(604)-5698, Project No. 7673, Task No. 76731, Scientific Rept 62-1 (Feb 1962) 20) P.C.T. deBoer, "The Curvature of Shock Fronts in Shock Tubes", Univ of Maryland, College Park, Md, Tech Note BN-297 (July 1962) 21) R. Stoops, Editor, "Energy Transfer in Gases", Solvay Institute 12th Chemistry Conference at Brussels Univ, Nov 5-10 (1962), Interscience, NY 22) J. Rosciszewski, "Solid Propellant Driven Shock Tube", ARS-J 32, 1426-27 (Sept 1962) 23) H.B. Palmer et al, "Computation of Kinetic Constants from Single-Pulse Shock Tube Data", AIAA-J 1, 1195-97 (May 1963) 23a) Sh. Fujimoto, BullChem-SocJapan 36(10), 1233-36 (1963) & CA 59, 15113 (1963) (Ignition delay of hydrogen-oxygen mixtures in a shock tube) 24) B. Lemcke, "Double Shock Tube for Simulating Blast Loading in Supersonic Flow", AIAA-J 1, 1417-18 (June 1963) 25) R.A. Strehlow, "Detonation Initiation", AIAA-J 2, 783-84 (April 1964) 26) T. Asaba et al, "Shock Tube Study of the Hydrogen-Oxygen Reaction", 10thSympCombstn (1965), 295-302 27) E.T. McHale et al, "Determination of the Decomposition Kinetics of Hydrazine Using a Single-Pulse Shock Tube", Ibid, 341-51 28) A.I. Lashkov, "Law of Motion of a Viscous Gas in a Shock Tube", InzhenernyiZhurnal 5(2), 254-60 (Mar-Apr 1965) 29) A.J. Laderman et al, "Gasdynamic Effects of Shock-Flame Interactions in an Explosive Gas", AIAA-J 3, 876-83 (May 1965) 30) A.G. Gaydon, "The Use of Shock Tubes for Studying

Fundamental Combustion Processes", 11th-SympCombstn (1967), 1-10 (Plenary Lecture) 31) I.R. Hurle, "Measurements of Hydrogen-Atom Recombination Rates Behind Shock Waves", 11thSympCombstn (1967), 827-36 32) T. Takeyama & H. Miama, "A Shock-Tube Study of the Ammonia-Oxygen-Reaction", Ibid, 845-52 33) R.M.R. Higgin & A. Williams, "A Shock-Tube Investigation of the Ignition of Lean Methane and n-Butane Mixtures with Oxygen", 12thSympCombstn (1969), pp 579-90 34) C.G. Dunkle, private communication, Dec 1969

Detonation, Shock Velocity in Air and Other Substances.

Savitt & Stresau (Ref 1) used a miniature-charge technique to det the vel decay of plane wave air shocks propagated in 0.15-inch ID tubes. The expls studied were Lead Azide, Lead Styphnate, MF, RDX, PETN, Tetryl & TNT. They found that the air shock vel, at a given distance, increased with chge length in LA between 0.05 & 0.40 inch. After a certain distance from the end of the chge, the decaying shock was overtaken by the expanding hot gas of the deton products. S&S pointed out that the initial shock waves in all expls studied were strongly supported rather than unsupported waves

Cook (Ref 2) determined (in collaboration with Mr O.K. Shupe), in the course of study of the shape and pressure distribution in the *detonation head*, that the *shock velocity* in steel is about 10% higher than the detonation velocity of granular RDX

Jaffe et al (Ref 3), in the course of determination of the shock pressure required to initiate detonation of an acceptor in the shock sensitivity test, found that the velocity of the front as sensed by the pressure probe method, falls behind the true velocity of the shock front as the shock is attenuated. It has also been found that the maximum transmitted *shock velocity* generated by the two Tetryl pellets and measured in Lucite is 4.6 mm/ μ sec. Shock velocities determined by optical method, shown in Table 3, p 25, run between 2.701

to 2.990 for Lucite vs 1.817 to 2.130 for water

Refs: 1) S.A. Savitt & R.H. Stresau, "Recent Air Shock Velocity Measurements Near Small Charges of Highly Confined Explosives", USNOL Rept 2442(1952)
2) Cook (1958), 345 3) I. Jaffe et al, ARS-J 32, 23-25 (1962)

DETONATION (AND EXPLOSION), SHOCK WAVE IN.

A *shock wave* is a violent disturbance moving with a loud bang along a medium (such as air, water, or earth), at a speed greater than that of sound ("supersonic speed"). Velocity of sound, c , in air is 331.9 m/sec (1088 ft/sec) and the ratio of shock velocity to sonic velocity is known as *Mach Number*, M

A shock wave is an integral part of a *detonation wave*, which is a combination of a shock wave and a *chemical reaction*. Each helps the other. The "pressure shock" initiates the reaction and the latter, by releasing energy at the required rate, prevents the dying out (fading) of the shock. Such a chemical reaction has to meet two requirements: increase in volume of products over that of original explosive and energy release - increase in sufficient quantity, by a process having a suitable sensitivity. Under these conditions the resulting pressure shock advances into the undetonated explosive carrying the chemical reaction along with it

Shock waves can be produced in a number of ways, such as movement of projectiles or other objects thru air at supersonic speeds, or pushing out of the air by the products of a detonation, which expand at many times the speed of sound. The latter type of shock wave is much stronger and is known as a *blast wave* (See under "BLAST EFFECTS IN AIR, EARTH AND WATER" in Vol 2 of Encycl, pp B180 to B184)

One of the simplest means of producing shock waves is to push the air along inside a long narrow tube, known as a *shock tube*. This method is briefly described here under

"Detonation, Shock Tube Technique Studies in" (Ref 33, pp 5-6)

Graphical presentation of formation of a shock wave by movement of a piston in a very long tube, previously filled with a material under consideration, (assumed to be at rest and of uniform composition, density, and temperature) was given by Kistiakowsky (Ref 15a) in Fig 1, p 949.

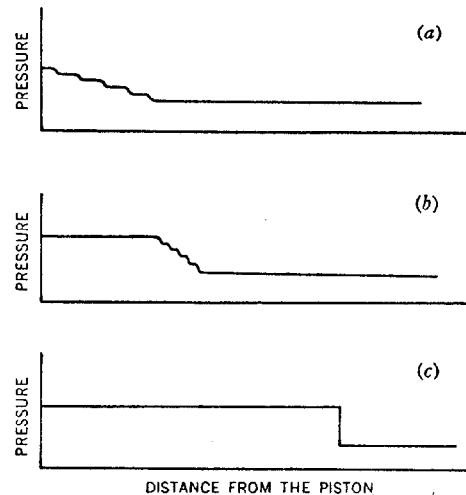

Fig 1 Formation of a shock wave: (a) an early instant; (b) later; and (c) still later

In his experiment the piston underwent several velocity increments, thus propagating a series of consecutive small shock waves thru the medium, each succeeding wave having higher velocity than the one in front of it. Eventually then, the waves all catch up with the first one. The result is a disturbance of finite amplitude with a very steep front. The last of these diagrams (c), represents the front as a discontinuous change in pressure; in real substances, the processes of diffusion and heat conditions make this impossible, and a finite pressure slope is maintained. At any rate, however, the slope is extremely steep and for the purposes of an elementary derivation of the equations of motion of such waves, it can be assumed that the change is discontinuous (Ref 15a, p 950)

Let us consider an initially stationary medium and a plane shock front propagating with a velocity U , and the initial and

peak values of pressure and density being p_0 , p , ρ_0 , and ρ , respectively. The laws of mechanics require the conservation of mass, momentum, and energy in the motion of matter thru discontinuity. If an observer will move forward with the shock front, to him the apparent velocity of the medium entering the front will be U , so that in a time dt , a mass $\rho_0 U dt$ will pass thru a unit area of the front and the same mass must leave the front. The "leaving" mass is equal to $\rho(U-u)dt$, if u is mass velocity of the medium in the wave relative to the stationary system of coordinates (u is the piston velocity in the example given before). Eliminating dt we can write:

$$\rho_0 U = \rho(U-u) \tag{Eq 1}$$

The momentum of the mass flow into the front is zero, because the medium is initially at rest; the momentum of the medium leaving the front with a velocity, u , is $\rho_0 U u dt$, and this increase of momentum must equal the impulse of the net force per unit area of the front, that is of the difference in pressure in the shock and in the medium at rest, $(p-p_0) dt$. Thus:

$$\rho_0 U u = p - p_0 \tag{Eq 2}$$

The equation representing conservation of energy is derived upon noting that the work, $p u dt$, done by the pressure, p , must equal the increase in the potential and kinetic energy of the medium. If the former is denoted by $e - e_0$ per unit mass, the latter being $\frac{1}{2}u^2$, with the mass, $\rho_0 U dt$, flowing thru unit area of discontinuity, the equation will be:

$$p u = \rho_0 U (e - e_0 + \frac{1}{2}u^2) \tag{Eq 3}$$

These three equations of conservation may be looked upon as defining any three of the four variables p , ρ , U , & u in terms of the 4th, if it is assumed that the equation of the medium, $f(p, \rho, T) = 0$, as well as the dependence of internal energy of any pair of these variables of state is known. Therefore, the properties of a stationary shock wave follow from the knowledge of the velocity of the piston maintaining the wave, which is also the material (particle) velocity, u

Substituting v for $1/\rho$ and v_0 for $1/\rho_0$, the following eqs are obtd:

$$p - p_0 = U u / v \tag{Eq 4}$$

$$\rho = v_0 \frac{U - u}{U} \tag{Eq 5}$$

$$U = (v_0 - v) \left(\frac{p - p_0}{v_0 - v} \right)^{1/2} \tag{Eq 6}$$

$$u = (v_0 - v) \left(\frac{p - p_0}{v_0 - v} \right)^{1/2} \tag{Eq 7}$$

$$e - e_0 = \frac{1}{2}(p + p_0)(v_0 - v) \tag{Eq 8}$$

Equation 8 is known as the Rankine-Hugoniot (R-H) Equation. Since, by assumption the functional dependence of e upon p & v is known, eq 8 permits the construction of R-H curve in the p, v plane, which describes the change in state of a medium upon the passage of a shock wave (See in Fig 2).

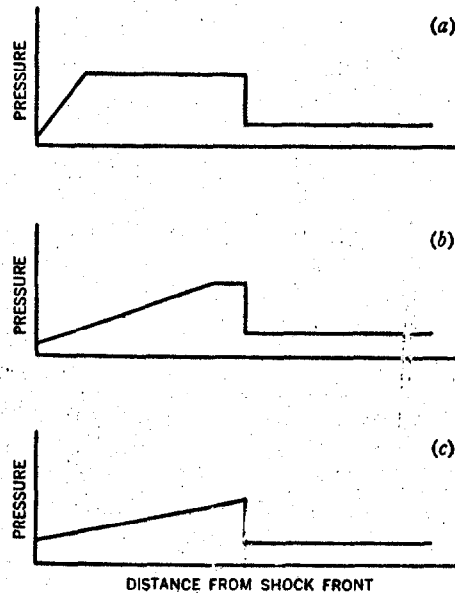

Fig 2 Decay of shock waves: (a) shortly after piston has been stopped; (b) later; and (c) still later, when rarefaction has overtaken shock wave

This curve resembles an adiabat but is quantitatively different from it, because pressure is rising steeper with increasing density. The density does not rise excessively in gaseous shock waves, but very high pressures and temperatures can be obtained. When a gas/or any other normal

fluid, after the passage of a shock) is expanded reversibly and adiabatically to its original volume and pressure, its temp is higher than initial because of the shape of the R-H curve; this means that shock compression is not reversible, or that the entropy of the medium is raised by the passage of a shock. Hence, shock waves dissipate energy (in the sense of the 2nd law of thermodynamics) and to maintain them, a steady supply of work must be provided. Such a shock wave is *supported*. The *spontaneous decay* of shock waves is understood when it is noted that the velocity of the shock wave relative to the (moving) medium in the wave (difference betw U and u in eqs 6 & 7) is less than the acoustic velocity, c, in this medium. If the piston of experiment listed in Ref 15a comes to rest, the medium adjacent to piston will also stop and this will cause a *rarefaction wave* to advance into the medium behind the shock wave. By the reversal of the same qualitative argument, it can be shown that a rarefaction wave spreads out as it propagates, instead of building up into a discontinuity, and that its front moves with the acoustic velocity thru the undisturbed medium ahead. Hence, the rarefaction wave overtakes the shock wave and gradually reduces its intensity. Fig 2 illustrates these events qualitatively. The instantaneous state of such decaying, unsupported, shock waves can be calcd when the value of any one of four variables in eqs 4-8 has been detd (Ref 15a, pp 950-52)

Table I (reproduced from Ref 15a, p 952) gives some of the properties of shock wave in air and in sea water; it shows that velocity of shock wave (U) is less than the sum of material (u) and sound (c) velocities

In the book of Taylor (Ref 18b, p 4), the shock waves formed in narrow tubes by the action of piston are called *non-reactive shock waves*. They were first discussed as early as 1860 by B. Riemann, but their importance for development of explosion theories did not become apparent until A. Schuster suggested in 1893 an analogy between them and *detonation waves*. He also pointed out that in all theories of detonation (including earlier approximate theories and the hydrodynamic theory), propagation of waves is explained in terms of physical properties of the products rather than those of the undetonated explosive

Taylor (Ref 18b, p 6) noted that a *detonation wave* is indeed a *reactive shock* in which release of chemical energy provides the requisite support, and in some way prevents rarefactions which arise in the products from overtaking the shock front

In Dunkle's Syllabus it is stated that a *shock wave* differs from a sound wave in: 1) Its higher velocity; 2) The finite pressure difference in the wave front; 3) The increase in temperature and density of the medium thru the wave; and 4) Physical flow of the material in the direction of advance of the wave. The rate of this flow, as well as that of wave propagation, and the magnitudes of the increases in density, tempera-

Table I Properties of Shock Waves

| Property | In air ^a | | | | | In sea water ^b | | | |
|-----------------------|---------------------|------|------|------|-------|---------------------------|------|------|-------|
| | p, atm | 1 | 1.87 | 3.3 | 41 | 625 | 1 | 5000 | 20000 |
| v/v ₀ | 1 | 0.63 | 0.44 | 0.19 | 0.167 | - | - | - | - |
| t-t ₀ , °C | 0 | 53 | 120 | 1720 | 25600 | 0 | 15.7 | 69 | 152 |
| U, m/sec | 340 | 455 | 600 | 2100 | 8160 | 1465 | 2230 | 3535 | 5100 |
| u, m/sec | 0 | 170 | 340 | 1700 | 6800 | 0 | 251 | 689 | 1235 |
| c, m/sec | 340 | 370 | 408 | 920 | 3310 | 1465 | 1975 | 2880 | 4020 |

^a P₀ = 1 atm; c_p/c_v = 1.40; and T = 273°K

^b P₀ = 1 atm; and T = 293°K

ture and pressure, can be evaluated by means of the Rankine-Hugoniot equations. They can all be represented as functions of the Mach Number (M) of the wave velocity (Ref 52, p 51)

Shock wave formed by supersonic motion of projectiles are usually weaker than those generated by powerful explosions, and the latter are sometimes called *blast waves*. In detonation, because of its extreme rapidity and the inertia of the surrounding air, the conversion into gases can be completed within the original volume of the explosive. Before the air has been forced into motion the pressure of the gases may reach 10^5 atm. The resulting extremely steep pressure gradient in the explosive-air boundary layer leads to the formation of a *compression shock wave* which propagates thru the atmosphere with a very high initial velocity (Ref 29a). Particle velocities are usually the major contributors to the momentum in such waves, known as *strong shock waves*. In *weak shock waves*, on the other hand, the greater part of the momentum is due to the static pressure. For example, at a wave velocity of 1030 miles per hour, the "excess pressure" is 1 atm, while generation of a "sonic bang" by a jet plane in breaking the sound barrier requires speeds of only 670-760 mph, depending on altitude. Accordg to computations of A.H. Yates, such a plane flying at 1000 ft altitude can give rise to a pressure increment of 10 psi at ground level. Waves of this magnitude could devastate large areas, toppling chimneys, causing roofs to fly apart, and even killing people. The shock pressure may even attain 50 psi, which is equivalent to a 140-mph hurricane. With such waves, smaller aircraft can be knocked down if they are closer than 10000 ft (Ref 52, p 52)

Although a shock wave may be attached to a projectile at its tip (Fig 3), detachment may occur at slower, though still supersonic, speeds. Or the other hand, a shock wave of a slowly-moving body becomes attached if it accelerates beyond a certain critical speed which varies for different geometrical forms (Ref 50). When the wave

is detached, it is invariably curved. At considerable distance to the sides it assumes very nearly the same angle as an attached wave, but in front of the body takes on a rounded shape. The flow is always subsonic behind the foremost portion of such a detached wave but may be supersonic farther out. Detachment angles at any given Mach Number (M) are larger for a cone than for a wedge and M must decrease to a lower value for detachment from a cone. If a body is very blunt, the shock wave ahead of it is detached at all speeds. The pressure change due to the presence of the body is transmitted upstream at subsonic speeds, so that even before reaching the obstruction, the air starts turning so as to bypass it. At supersonic speeds the pressure pulses or signals cannot travel upstream; the air has no "warning" that the body exists until very close to it, where the air ahead has just collided with the obstruction and is only then being turned to pass around it. As the air slows down very rapidly, its pressure and density increase correspondingly. When the denser air is flowing away from in front of the body rapidly enough to accommodate the mass flow of air into the region, a steady equilibrium condition results. The compressed region extends somewhat out ahead, depending on geometrical factors and the initial velocity and temperature of the air. This condition approaches, as a limit, a compression wave thru which the changes occur, and free-stream conditions will prevail ahead of the wave (Fig 3). A very strong compres-

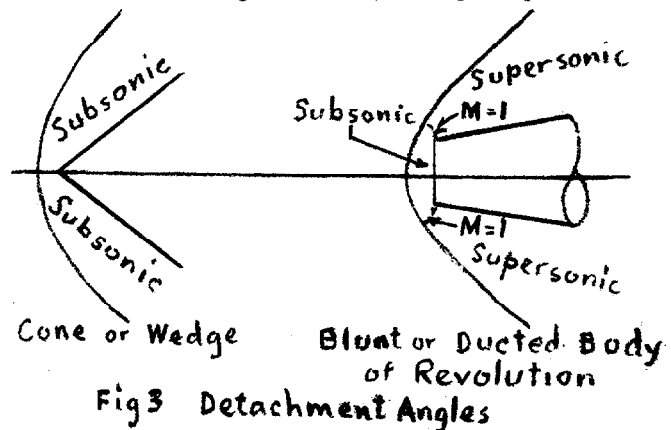

sion wave thus forms normal to the direction of flow. The density and pressure increase very greatly, and the velocity decreases from supersonic to subsonic. Loss in total pressure is relatively high thru this type of shock wave (Ref 52, pp 52-3)

The compressible flow about an ogive with attached shock was investigated by Spencer (Ref 22a)

Conditions behind shock waves were investigated by several scientists, among them Martin (Ref 22b), Jones (Ref 25), Armendt et al (Ref 37), Makino (Ref 37a) and others. Results of their work are described in Ref 52, pp 53-6

Hornig (Refs 40 & 66c) discussed energy exchange in shock waves

Dunkle in private communication of Nov 1968 gave the following résumé of Ref 66c:

In a coordinate system fixed in the shock front the undisturbed gas flows in at the shock velocity Mc . The kinetic energy per gram of gas, $\frac{1}{2}(Mc)^2 = M^2\gamma RT/2$, greatly exceeds the mean thermal energy $3RT/2$, if $M^2 \gg 3/\gamma$. (In a detonation, M is roughly 3-6). In the shock front, according to the continuity equation, the velocity decreases to a fraction ρ_1/ρ_2 of the incoming velocity and the kinetic energy to a fraction $(\rho_1/\rho_2)^2$. Thus, substantially all of the flow is degraded to thermal energy, with randomization by collision of the initially parallel flow of gas
Note: Here M =Mach number, c =velocity of sound, R =gas constant, T =temperature in $^{\circ}K$, $\gamma=C_p/C_v$ where C_p & C_v are the molar heat capacities at constant pressure and constant volume, respectively; and ρ_1 & ρ_2 are the densities of the undisturbed & shocked gases, respectively

The thickness of the compression zone is about 10^{-5} cm at atmospheric pressure; thus the time for compression is about 10-10 sec. Since the wave length of visible light is of this order of magnitude, the optical reflectivity method was developed. Experiments were carried out in which the angle of incidence on the shock front was kept constant, and the angle of observation varied. In the case of simple air shock

waves, reflected light was visible only when the angles were within 2° of each other. In detonation waves, signals were visible over a wide range, and there was no sign of a maximum indicating reflection from a plane front. It would appear that a complex wave structure or turbulence persists in detonations up to several atmospheres initial pressure, and that the properties of the detonations are influenced by turbulent heat transfer rather than molecular relaxation processes. Some part of the signal may be due to genuine reflection from a rough front. Pressure pulses expanding laterally may be due to fluctuations of the chemical reaction in small elements of the gas which has just passed thru the shock front after being compressed there and heated. In this connection, the paper of Manson, et al (Ref 71a) noted the following:

The "instabilities" can be interpreted on supposing the existence of vibratory phenomena since the frequency of the quasi-horizontal striae visible on the photos of the burnt gases accords well with the frequency calculated on the supposition that these vibrations are transverse; this frequency can attain very high values (many Mc/sec)

In mixtures near the limit, the shock wave and the flame separate momentarily, and the gases behind the shock are then the seat of vibratory phenomena, not only transverse but also longitudinal (of the same frequency as in the burnt gases). It would appear from this that such phenomena, but at even higher frequency, exist in the gas layer separating the shock wave and the flame of detonations propagating under conditions far removed from the limits, and that they play an important role in the coupling of the shock and the flame

Most of the previous discussion applied to shocks in an inert medium. In an explosive or other thermodynamically unstable medium, however, the arrival of the shock front causes a chemical reaction to happen which is one of the criteria of detonation. In fact, Cole (Ref 9a, p3) has noted that explosion is accompanied by "a chemical reaction in a substance which converts the

original material into gas at very high temperature and pressure, the process occurring with extreme rapidity and evolving a great amount of heat". Even in the so-called nongaseous expls the material may be in vapor form at the temp of expln. The important point is that chemical energy is transformed into heat and mechanical energy. This reinforces shock and prevents the rarefaction wave from overtaking and extinguishing the shock front (Ref 33, p 7)

Cook (Ref 53) in Chapter 13, entitled "Shock Waves in Gaseous and Condensed Media" gives a comprehensive description of this subject. Following are some abstracts and highlights from this chapter:

"The *initial* 'shock' wave in air from a detonation has apparently only a very short life, being superseded or swallowed up by another more energetic wave after propagation of only a few diameters from the charge. The wave that finally emerges from the expanding gas cloud comprising the products of detonation is, moreover, quite different than the initial shock; while it has a much lower peak pressure, it is much broader and much more energetic". Payman (Ref 1), recognizing the vast difference between these two disturbances, called the initial one the *shock wave* and the latter the *pressure wave* (Ref 53, p 322-L). It is also called *compression wave*

Savitt & Stresau (Ref 18a) using the "miniature charge technique", briefly described by Cook on p 41, determined the velocity decay of plane-wave air shocks propagated in several HE's placed in a 0.15-inch ID tube over a distance ranging from 0.1 to 10 inches. Results of their experiments are listed in Ref 53, pp 322-23 and also on p 195, where Fig 8.16 gives shock velocity V^* versus distance from the charge S and average velocity V_1^* versus S for propagation by influence in air for a straight Dynamite and for 65/35 Tetrytol. Symbol D of Fig 4 stands for detonation velocity and d for density. Results of tests showed that in the initial shock propagation (after a certain distance from the end of the charge) the decaying shock is overtaken by the expanding gas cloud of

detonation products. Savitt & Stresau also showed that if initial shock waves are plane, they are *supported*, but if they are *curved* (and hence divergent), as in unconfined charges depicted in Fig 4, they are *unsupported*. Finally it has been stated that the "initial shock wave" is really the *plasma* and perhaps it does not have shock wave character at all but is nearly "shockless" (Ref 53, p 323)

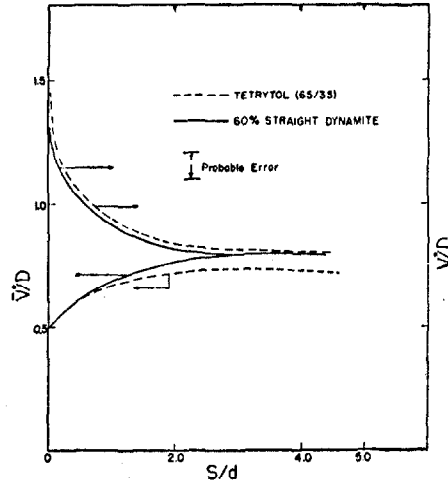

Fig 4 Shock velocity V^* versus S and average velocity V_1^* versus S for propagation by influence in air for a straight dynamite and 65/35 tetrytol

Study of the blast contours of HE's provides $V^*(S)$ data for the *lateral initial shock wave* during its lifetime, i.e. in the interval between its creation and obliteration by the oncoming pressure wave. It is known that the actual particle-velocity vector of the initial lateral shock wave is not quite perpendicular to the charge axis, but somewhat in the forward position (Ref 53, p 323)

Under the title "Formation of Pressure Wave", Cook (Ref 53, p 324) related the pressure rise in the front of an air "shock" wave to the point at which the initial air shock wave from unconfined charges is obliterated by the emerging gas cloud of the products of detonation. His table 13.3 (our Table 2) presents some selected thermodynamic data computed by R. Becker for air shocks relating, among other quan-

ities, the velocity V^* to the pressure rise in the shock front. Here π =relative pressure p_2/p_1 ; p =pressure; v =specific volume, T =temperature in $^{\circ}\text{K}$ and W =particle velocity. Subscript 1 applies to the original explosive and subscript 2 to the conditions at the Chapman-Jouguet plane (Ref 53, p 376)

Table 2
Thermodynamic Data
for Air Shock

| $\pi=p_2/p_1$ | v_1/v_2 | $T_2(^{\circ}\text{K})$ | W mm/ μsec | V^* mm/ μsec |
|---------------|-----------|-------------------------|----------------------------|------------------------------|
| 2 | 1.63 | 336 | 0.175 | 0.452 |
| 5 | 2.84 | 482 | 0.452 | 0.698 |
| 10 | 3.88 | 705 | 0.725 | 0.978 |
| 50 | 6.04 | 2260 | 1.795 | 2.15 |
| 100 | 7.66 | 3860 | 2.59 | 3.02 |
| 500 | 11.15 | 12200 | 5.98 | 6.57 |
| 1000 | 14.30 | 19100 | 8.56 | 9.21 |
| 2000 | 18.80 | 29000 | 12.21 | 12.90 |
| 3000 | 22.30 | 36700 | 15.05 | 15.75 |

Cook also described "Initiation of Detonation by Underwater Shocks" (Ref 53, pp 330-34); "Shock-Wave Propagation in Solid Media" (pp 334-37) and "Shock-Wave (or Stress Wave) Fracturing of Rock" (pp 339-41)

In the "Summary of Results of Long-Range Ground Shock Studies", Cook described (pp 370-75) *Ground Shock-Wave Disturbances Created at Long-Range by Explosives*. These explosions are complex and vary markedly not only from one place to another but in a given location, even with constant changes, cover and distance. Three types of ground-wave disturbances have been observed in the US Army demolition operations where the charges were fired above or on the surface of the ground or beneath a small dirt cover. These were as follows:

- a) Direct or surface ground waves - called "S-waves"
- b) Indirect or subsurface waves - called "SS-waves"
- c) Air-blast-induced ground disturbances - called "induced ground waves"

These waves are shown in Figs 14.12a & 14.12b, p 371 and Fig 14.13a, p 374 of Ref 53. A more detailed discussion of this subject

is given on pp 371-75 of Ref 53. See also "Limits of Damage by Ground Blast Waves" (pp 357-60) and in Vol 2 of Encycl, p B182-R, "Blast Effect in Earth"

For more detailed description of shock waves and their properties, see Refs which follow. In these Refs are described, among others, the following items:

Definition and theory of shock waves (Refs 12a, 18, 32a & 33); Initiation of shock waves in air (Refs 15b, 68 & 71); Initiation of shock waves underwater (Refs 53 & 53a); Interaction of shock waves (Refs 11, 15, 19, 51, 52 & 65); Attenuation (decay) of shock waves (Refs 10, 37, 46, & 77); Energy in shock waves (Refs 40 & 72); Ionization in shock waves (Ref 53); Light (luminescence) produced by shock waves (Refs 19 & 21); Spectra of shock waves (Ref 30); Temperature in shock waves (Refs 9, 38 & 48); Velocity of shock waves (Refs 18a, 24 & 65b); Particle velocity in shock waves (Ref 45); Propagation of shock waves (Refs 73a & 74); Thickness of shock waves (Refs 17, 26 & 37); Normal shock waves (Refs 25, 27 & 52); Oblique shock waves (Refs 51, 52 & 54); Plane shock waves (Refs 3, 16, 41, 51, 52, 62, 68 & 78); Cylindrical shock waves (Refs 42 & 58); Spherical shock waves (Refs 12, 23, 42, 52, 59, 65a, 68a & 83) (See also under DETONATION (EXPLOSION AND COMBUSTION), SPHERICAL SHOCK WAVES IN); Supported and unsupported shock waves (Ref 52); Strong shock waves (Refs 8, 14, 48 & 52); Weak shock waves (Refs 36 & 60); Explosion products behind shock waves (Refs 2 & 67)

Re/s: 1) Wm. Payman, PrRoySoc **120A**, 90(1928) (Shock and pressure waves)
1a) Wm. Payman et al, PrRoySoc **148A**, 604-22(1935) & CA **29**, 4586(1935) (Shock wave and expln products sent out by blasting detonators) 2) Wm. Paymen & D.W. Woodhead, Ibid **163A**, 575-92(1937) & CA **32**, 2752(1938) (Shock wave and expln products from detonating solid explns)
3) G.B. Kistiakowsky & E.B. Wilson Jr, "Report on Plane Shock Waves", OSRD Rept **70** (Jan 1941) 4) Ibid, "Final Report on the Hydrodynamic Theory of Detonation and Shock Waves", OSRD **114**

- (June 1941), p 7 (Simple shock waves in an ideal gas); 34 (Properties of shock and rarefaction waves) 4a) S. Chandrasekhar, "On the Decay of Plane Shock Waves", BRL Rept **423** (Nov 1943), Aberdeen Proving Ground 5) A.A. Grib, *PriklMatem i Mekhan* **8**, 273 (1944) (Influence of the initiation point on the parameters of an atmospheric shock wave upon detonation of explosive gas mixtures) 6) L.D. Landau, *Ibid* **9**, 286 (1944) (Derivation of the limiting amplitude-variation law of propagating waves of weak intensity) 7) Ya.B. Zel'dovich, "Teoriya Udarnykh Voln i Vvedeniye v Gazodinamiku" (Theory of Shock Waves and Introduction to Gasdynamics), Tipogr-AkadNauk, Moscow (1946) 8) R.G. Sachs, *PhysRev* **69**, 514-22 (1946) (Some properties of very intense shock waves) 9) S.B. Ratner, *ZhFizKhimii* **20**, 1377-80 (1946) & *CA* **41**, 3297 (1947) (An estimation of the temperature of liquid organic nitrates in the shock wave. Temp of NG in which a shock wave progresses can reach 3000°) 9a) R.H. Cole, "Underwater Explosions", PrincetonUnivPress, Princeton, NJ (1948), pp 110-46 & 228-ff 10) K.O. Friedrichs, "Formation and Decay of Shock Waves", Inst for Math & Mech, NY Univ, Navy Contract **No 6-ord-201**, Task Order No 1, May 1947 11) R. Courant & K.O. Friedrichs, "Supersonic Flow and Shock Waves", Interscience, NY (1948) (Reprinted in 1960), p 204-35 12) R.G. Stoner & W. Bleakney, *JApplPhys* **19**, 670-78 (1948) (Attenuation of spherical shock waves in air) 12a) W.B. Cybulski, *PrRoySoc* **197A**, 51-72 (1949) (Explosion waves and shock waves) 13) H.A. Bethe & E. Teller, "Deviation from Thermal Equilibrium in Shock Waves", BRL Rept **X-117** (1949) 14) Ya.B. Zel'dovich & I.Ya. Shliapintokh, *DoklAkadN* **65**, 871 (1949) (Ignition of explosive gaseous mixtures in shock waves) 15) W. Bleakney & A.H. Taub, *RevsModernPhys* **21**, 584-605 (1949); *SciAbstracts* **53A**, 286-87 (1950) (Interaction of shock waves) 15a) G.B. Kistiakowsky, "Theory of Shock Waves", pp 949-52 in Kirk & Othmer **5** (1950) (Not found in 2nd edition of Kirk & Othmer) 15b) L. Obert & W.I. Duvall, "Generation and Propagation of Strain Waves in Rock", *USBurMines RI* **4683** (1950) 16) S. Travers, *MAF* **24**, 443-50 (1950) & *CA* **45**, 8772 (1951) (Present state and value of the hydrothermodynamic theory of explosions and shocks, I. The plane shock waves; compressibility by shock without combustion) 17) *Ibid* **25**, 421-624 & 923-1006 (1951) (Thickness of shock waves and mechanism of inflammation in combustion waves) 18) T. Von Kármán, *Termotecnica* (Milan) **5**(2), 82-3 (Feb 1951) (in Ital); Engl abstract in *Applied Mechanics Reviews* **4**, 517 (Sept 1951) (Theory of shock waves and the 2nd law of thermodynamics) 18a) J. Savitt & R.H.F. Stresau, "Recent Air Shock Velocity Measurements Near Small Charges of Highly Confined Explosives", *USNOL-NavOrdRept* **2442** (1952) 18b) Taylor (1952), pp 4-6 (Non-reactive shock waves); pp 65-7, 69, 72 & 76-7 (Shock front in detonation waves); 30-2 (Light produced by shock waves) 19) E.M. Fisher, "Experimental Investigation of the Interaction of Overtaking Shock Waves in Air", *USNOL-NavOrd* **2909** (1953) 20) L. Deffet & P.J. van de Wouwer, *Explosifs* (Liège) **6**, 9-20 (1953); *Chim & Ind* (Paris) **69**, 1086-87 (1953) & *CA* **49**, 6608 (1955) (Luminosities produced by shock waves) 21) T. Sakurai, *JIndExplsSocJapan* **14**, 257-64 (1953) & *CA* **49**, 11284 (1955) (Propagation velocity of shock waves in solids) 22) E.F. Green & D.F. Hornig, "Chemical Reactions in Strong Shock Waves", BrownUniv, ONRContract Nonr-562(06)-NR 357-275, *TechRept No 1* (Dec 1953) 22a) G.L. Spencer, "The Compressible Flow about an Ogive with Attached Shock", Univ of Md OOR Contract DA-36-034-ORD-1486. Preliminary Rept **No 14** (1954) 22b) M.H. Martin, "The Propagation of a Plane Shock into a Quiet Atmosphere", Univ of Md OOR Contract-ORD-1486 Preliminary Rept **No 17** (1954) [See also Status Rept 1 (1955)] 23) H. Schardin, "Measurement of Spherical Shock Waves", 1st AMS SympApplMathematics **1954**, 223-43 24) T. Hikita, *JIndExplsSocJapan* **15**, 250-57 (1954) &

- CA 49, 11281 (1955) (Calculation of the velocity of shock wave produced by an explosion) 25) C.W. Jones, *PrRoySoc* **221A**, 257-67 (1954) (On gas flow in one dimension following a normal shock of variable strength) 26) S.L. Lipsitz, "Thickness of Shock Waves", *AF Inst of Tech, Wright-Patterson AFB Rept GAE* **54** (1954) 27) A.H. Shapiro & S.J. Kline, "On the Thickness of Normal Shock Waves in a Perfect Gas", *OOR-Case Inst of Tech, Contract DA-33-019-ORD-1116* (1954) 28) S.P. D'yakov, *ZhEksp i TeoretFiz* **27** (c), 728-34 (1954) (in Russian) (Shock waves in a relaxing medium) 29) R.H. Christian et al, *JChemPhys* **23**, 2042-49 (1955) (Equation of state of gases by shock wave measurements) 29a) A. Haid, "The Distant Effects of Detonation", *Explosivst* **3**, No 9 (Sept 1955) (*PicArns Translation No 5* by G.H. Loehr, June 1956) 30) A.F. Fairbanks & A.G. Gaydon, *Nature* **175**, 253-54 (1955) (Comparison of the spectra produced by shock waves, flames and detonations) 31) W.A. Allen et al, *JAppl-Phys* **26**, 125-26 (1955) (Shock waves in air produced by elastic waves in a plate) 32) C.E. Duvall & B.J. Zwolinski, *IEC* **47**, 1182 (1955) (Entropic equations of state and their application to the shock wave phenomena) 32a) Anon, "Military Explosives", **TM 9-1910** (1955), pp 37-9 (Shock waves and shock front). Superseded by **TM 9-1300-214/TO 11A-34** (1967) 33) C.G. Dunkle, Lecture delivered at Picatinny Arsenal, Dover NJ on Dec 13, 1955; p 6 (Definition of shock wave) 34) Ya.B. Zel'dovich & A.S. Kompaneets, "Teoriya Detonatsii" (Theory of Detonation), *GosTekhIzdat, Moscow* (1955); Engl transl published in 1960 is listed here as Ref 60 35) V.P. Korobeinikov, *DoklAkadN* **111**, 557-59 (1956) (*ATS Engl Transl RR-784*) (Approximate formulas for calculation of the characteristics of a shock wave front in the case of a point explosion in a gas) 36) G.B. Whitham, *JFluidMech* **1**, 290-318 (Sept 1956) (On the propagation of weak shock waves) 37) B.F. Armendt et al, "The Initial Decay of Pressure Behind a Shock Front," *APG-BRLM* **997** (1956) 37a) R.C. Makino, "An Approximation Method of Blast Calculations", *APG-BRLM* **1034** (1956) 37b) G.P. Wood, "Calculations of the Rate of Thermal Dissociation of Air Behind Normal Shock Waves at Mach Numbers of 10, 12 and 14", *NACA (National Advisory Committee for Aeronautics) TechNote* **3634** (1956) 38) G.E. Duvall & M.C. Kells, "Production of High Temperatures in Shock Waves", pp 53-58 in "Proceedings of the Symposium on High Temperature - A Tool for the Future", *StanfordResInst, Berkeley, Calif*, 25, 26 & 27 June (1956), *Menlo Park, Calif* (1956) 39) R.A. Strehlow, "One Dimensional Step Shock Wave Equation for Ideal Gases", *BRL* **978** (1956) 40) D.F. Hornig, *JPhysChem* **61**, 858-60 (1957) (Energy exchange in shock waves) 41) N.C. Freeman, *JFluidMech* **2**, 4 (June 1957) (On the stability of plane shock waves) 42) R.F. Chisnell, *Ibid* **2-3**, 296-98 (1957) (Motion of shock wave in a channel with applications to cylindrical and spherical shock waves) 43) J.M. Walsh et al, *PhysRev* **108**(2), 196-216 (Oct 1957) (Shock wave compression of 27 metals) 44) J.J. Jones, "Experimental Investigation of Attenuation of Strong Shock Waves in a Shock Tube with Hydrogen and Helium as Driver Gases", *Langley Aeronautical Field, NACA TN4072* (1957) 45) T. Sakurai, *KogyoKayakuKyokaishi* **18**, 41-49 (1957) & *CA* **51**, 5159 (1957) (Particle velocities of shock waves produced in a lead column by the attack of detonating explosives) 45a) D.F. Hornig, "Energy Exchange in Shock Waves", *JPhysChem* **61**, 856-60 (1957) & *CA* **51**, 17296 (1957) 46) R. Kawamura & H. Kawada, *JPhysSocJapan* **12**, 1290-98 (1957) (A study on the attenuation of shock waves due to obstacles in the passage) 47) F.T. Harris et al, *DOFL (Diamond Ordnance Fuze Laboratory) TechReview* **1**, 105-23 (Oct 1957) "Spark Shock Waves in a Supersonic Wind Tunnel" 48) I.Sh. Model, *Soviet Physics JETP* **5**, 589-601 (Nov 1957) (Engl transl of *ZhEksp-TeoretFiz*, listed in Vol 1 of *Encycl*, p Abbr 76) (Measurement of high temperatures in strong shock waves in gases)

- 49) Ya.B. Zel'dovich, *Ibid* **5**, 919-27 (1957) (Shock waves of large amplitude in air (in Engl) 50) J.R. Katz, "Detached Shock Waves Ahead of Buff-Nosed Cylinders", *NOTS* **1686**, *NavOrd* **5423** (1957) 51) W. Drummond, *JApplPhys* **28**, 76-85 (1957) (Interaction of nonuniform shock waves); *Ibid*, **28**, 1437-41 (1957) (Plane shock waves) and *Ibid* **29**, 167-70 (1958) (Oblique shock waves) 52) Dunkle's Syllabus (1957-1958). *Properties of Shock Waves*, which include: Supported Shock Waves (pp 50-1); General Properties of Shock Waves (51-2); Detachment of Shock Waves (52-3); Conditions Behind Shock Front (53-6); Variability of Specific Heats (56-7); Relaxation Processes, Ionization, and Chemical Reaction (57-60); and Shock Waves in Solids (60). *Shock Relationships and Formulas*, which include: Changes During Steady Reversible Compressible Flow (61-4); Pressure-Velocity Relationship (65-6); Irreversibility and Degradation (66-8); Derivation of Formulas (68-70); Pressure Efficiency Factor and Recovery Factor (70-2); and Oblique Shocks in Air (72). *Shock Wave Interaction*, which includes: Strong Shock Waves (81); Superposition of Plane Shock Waves (81-2); Normal Reflection of Shock and Rarefaction Waves (82-4); Types of Interaction (86); Normal Reflection of Rarefaction (86-7); Normal Refraction of Shock and Rarefaction Waves (87-8); Head-on Collisions (88-9); Oblique Intersections (89-90); Oblique Interactions (90-1); Spherical Shock Waves (97-8); Distinction Between Shock and Detonation Fronts (163-66); Application to Solid Explosives (166-68); Principle of Similarity and Its Application to Shock Waves (307-10); Effects of Ionization in the Shock Front (387-90)
- 53) Cook (1958), Ionization in Shock Waves (pp 153-58); Thermal Effects of Shock Waves in Solids (213-16); Stability of a Shock Wave in an Inert Solid (216); Chapter 13. *Shock Waves in Gaseous and Condensed Media*, which includes: Mechanism of Formation and Propagation of Shock Waves in Air and Water (322-24); Formation of Pressure Wave (324-26); Propagation of Pressure Wave in Air (326-27); Underwater Explosions (327-30); Initiation of Detonation by Underwater Shocks (330-34); Shock-Wave Propagation in Solid Media (334-36); Seismic Disturbances from Large Confined Shots (337-39); Shock-Wave (or Stress-Wave) Fracturing of Rock (339-41); Stress-Wave Fracturing of Metals (341-43); Corner Fracturing (343-44); Fracturing by Release of Load (344-46); Fracturing by Relative Motion of Load (346); Shear Fracture (346-47). Chapter 14, *Damage Potential of Air and Ground Blast Waves*, which includes: Summary of Results of Long Range Ground Shock Studies (370-75) 53a) C.H. Winning, *PrRoySoc* **246A**, 288-96 (1958) (Underwater shock-wave initiation of cast Pentolite) 54) P.B.L. Taylor, "The Oblique Shock-Compression Wave Interaction in Shock Refraction", *PennState-Univ, Dept of Phys, TechRept* **531-1** (1958) 55) I.G. Campbell & A.S. Pitcher, *PrRoySoc* **243A**, 534-45 (1958) (Shock waves in a liquid contg gas bubbles) 56) R. Schall, *Explosivst* **6**, 120-4 (1958) (Shock waves) (9 refs) 57) M. Suzuki et al, *MemDefense-AcadJapan* **2**, 67-74 (1958) (in Engl) & *CA* **58**, 404 (1963) (Ignition of detonable gaseous mixts by shock waves) 58) F.D. Bennett, *Phys of Fluids* **1**, 347 (1958) (Cylindrical shock waves from exploding wires) 59) Baum, Stanyukovich & Shekhter (1959), pp 182-224 (Elementary theory of shock waves); 318-62 (Parameters of shock waves); 598-624 (Theory of "point" explosion and strong shock waves); 624-40 (Spherical explosion); 664-81 (Propagation of shock waves in condensed media); 664-81 (Propagation of spherical shock wave in water) 60) Ya.B. Zel'dovich & A.S. Kompaneets, "Theory of Detonation", *Academic Press*, NY (1960), translated from book in Russian, published in 1955, listed here as Ref 34, pp 7-18 (Elementary theory of shock waves); 18-28 (Weak shock waves); 28-33 (Shock waves in an ideal gas); 96-108 (Propagation of chemical reaction) 61) Andreev & Belyaev (1960), 338-83 (Shock waves) 62) G.E. Seay & L.B. Sealy Jr, "Initiation of Low Density PETN Pressing by a Plane Shock Wave", *3rdONRSympDeton* (1960),

- 562-73 63) E.L. Kendrew & E.G. Whitbread, "The Transfer from Shock Wave to Detonation in 60/40-RDX/TNT", *Ibid*, 574-83 64) V.S. Ilyukhin et al, *DoklAkadN* **131**, 793-96(1960); Engl transl in *Soviet Physics, Doklady* **5**, 337-40(1960); *CA* **55**, 24013(1961) (Measurement of adiabatic shock waves in cast Trotyl, crystalline Hexogen and Nitromethane) 65) Dunkle's Syllabus (1960-1961): *Shock Waves*, which includes: Mathematical Background (Sessions 1 & 2); Fluid Flow (Session 3); Initiation of Shock Waves (Session 4); Properties of Shock Waves (Session 5); Shock Relationships and Formulas (Session 6); Shock Wave Interactions (Sessions 7 & 8) 66) B.D. Khristoforov, *ZhPriklMekhan i TekhnFiz* **1961**, No 6, 175-82 & *CA* **56**, 14520(1962) (Parameters of the front of the shock wave in air at detonation of PETN and LA of various densities) 66a) N.L. Colburn & B.E. Drimmer, "Spherical Shock Waves in Water", *APS (American Physical Society) Bulletin, Ser II, Vol 7*, p 20 (Jan 24, 1962) 66b) G.G. Rempel, pp 561-76 in "Teoriya Vzryvchatykh Veshchestv", *Sbornik Statey*, edited by K.K. Andreev, Moscow (1963) (Determination of shock-wave velocities required for initiation of detonation in explosives); *CA* **59**, 11180(1963) 66c) D.F. Hornig, "Energy Exchange in Shock and Detonation Waves", *InstInternlSolvayConseilChim* **12**, 311-33; discussion, 334-39 (1962) (In English) (A review with 30 refs); *CA* **61**, 8905(1964) 67) O.A. Tsukhanova, "Investigation of the State of Explosion Products Behind the Shock Wave", *8thSympCombstn*(1962), 323-28 68) C.H. Johanson et al, "Initiation of Solid Explosives by Shock Waves", *Ibid*, 842-47 & *CA* **57**, 6198(1962) 68a) H.H. Calvit & N. Davids, "Spherical Shock Waves in Solids", *Penn-StateUnivTechRept* **2** (July 1963)(Contract DA-36-034-ORD-35761RD) 69) Sh. Fujimoto, *BullChemSocJapan* **36**(10), 1233-36 (1963) & *CA* **59**, 115113(1963)(Chemical reaction in a shock wave) 70) C.E. Duval & G.R. Fowles, "Shock Waves", pp 209-91 of Vol 2 of "High Pressure Physics and Chemistry", edited by R.S. Bradley; Academic Press, NY (1963) 71) J. Laderman et al, "On the Generation of a Shock Wave by Flame in an Explosive Gass", *9thSympCombstn*(1963), pp 265-74 71a) N. Manson, "Vibratory Phenomena and Instability of Self-Sustained Detonation in Gases", *Ibid*, pp 461-69 71b) D.C. Pack & F.J. Warner, "Whitham's Shock-Wave Approximation Applied to the Initiation of Detonation in Solid Explosives", *10thSympCombstn*(1965), pp 845-53 72) L.P. Orlenko & L.P. Parshev, *ZhPriklMekhan i TekhnFiz* **1965**(5), 130-31 & *CA* **64**, 3274(1966)(Calculation of the energy of a shock wave in water) 72a) W.A. Walker & H.M. Sternberg, "The Chapman-Jouguet Isentrope and the Underwater Shockwave Performance of Pentolite", *4thONRSympDeton*(1965), pp 27-38(26 refs) 73) R. Chéret, "Theoretical Considerations on the Propagation of Shock and Detonation Waves", *Ibid*, pp 78-83 74) A.B. Amster et al, "Detonation of Nitromethane-Tetranitromethane Mixtures: Low and High Velocity Waves", *Ibid*, pp 126-34 75) J.B. Ramsay & A. Popolato, "Analysis of Shock Wave and Initiation Data for Solid Explosives", *Ibid*, pp 233-38 76) J. Thouvenin, "Effect of a Shock Wave on a Porous Solid", *Ibid*, pp 258-65 77) J.O. Erkman, "Elastoplastic Effects in the Attenuation of Shock Waves", *Ibid*, pp 277-88 78) J.C. Pearson, "Hydrodynamic Elastic Plastic Theory and Plane Shock Waves in Metals 1. Theory, *Ibid*, p 289 (Abstract) and *PATR* **3464** (March 1967) 79) W.E. Deal, "Shock Wave Research on Inert Solids" (Invited Review), *4thONRSympDeton*(1965), pp 321-45 79a) T.P. Liddiard, Jr, "Initiation and Burning in High Explosives by Shock Waves", *Ibid*, pp 487-95 (19 refs) 80) W.L. Murray & J. Plant, "A Method for the Study of Properties of Solid Explosives and Other Solid (Including Porous) Materials When Subjected to Shock Waves", *Ibid*, pp 555-65 81) C. Peyre et al, "Experimental Method of Analysis of the Structure of a Shock Wave in a Solid", *Ibid*, pp 566-72 82) D. Venable & T.J. Boyd Jr, "PHERMEX Applications to Studies of Detonation Waves

and Shock Waves", Ibid, pp 639-47 (PHER-MEX is a 20-MeV, high intensity, high current, flash radiographic machine built at the LosAlamosScientificLaboratory to complement other hydrodynamic facilities of the lab) 83) L. Rudlin, "Origin of Shock Waves from Spherical Condensed Explosives in Air", NOLTR 63-220(1963) 84) B. Koch, BerBunsengesPhysChem 70 (9-10)(1966) & CA 66, 1995 (1966), "Studies of Detonation and Shock Wave Fronts by Using Microwaves". Its abstract is given in Ref 83 under DETONATION (AND EXPLOSION) WAVES 85) C.W. Hamilton & G.L. Schott, "Post-Induction Kinetics in Shock Initiated H₂-O₂ Reactions", 11th-SympCombstn (1967), pp 635-43 86) P.A. Urtiew & A.K. Oppenheim, "Detonative Ignition Induced by Shock Merging", Ibid, pp 665-70 87) M. Cowperthwaite & G.K. Adams, "Explicit Solutions for Steady- and Unsteady-State Propagation of Reactive Shocks at Constant Velocity", Ibid, pp 703-11 88) Anon, "Military Explosives", TM 9-1300-214/TO 11A-1-34(1967), pp 5-24 to 5-27 (Shock wave and shock front) [Superseding TM 9-1910 (1955)] 89) W.A. Sirignano, "A Theory of Axial-Mode Shock-Wave Oscillations in a Solid-Rocket Combustor", 12thSympCombstn (1968), pp 129-37 90) G.L. Schott, "Chain Branching and Initiation Rates Measured by Spatially Integrated Light Emission During Reflected Shock-Wave Ignition", Ibid, pp 569-78 91) M. Cowperthwaite, "Explicit Solutions for the Buildup of an Accelerating Reactive Shock to a Steady-State Detonation Wave", Ibid, pp 753-59 92) V.P. Karpov & A.S. Sokolik, "On the Mechanism of Generation of Shock Waves, Their Amplification on Interaction with the Flame and Transition to Detonation", Ibid, Abstracts, Paper No 85, pp 149-50 93) F.S. Billig & G.L. Dugger, "The Interaction of Shock Waves and Heat Addition in the Design of Supersonic Combustors", Ibid, pp 1125-39

Detonation, Shock Wave; Principle of Similarity, Its Application and Scaling Effects in. The most direct predictions concerning the behavior of shock waves are embodied in the *principle of similarity* and the conclusions drawn from it. Accordg to this principle, if the linear dimension of the expl chge and all other lengths are altered in the same ratio for two samples, the shock waves formed will have the same pressures at corresponding distances scaled by the ratio, if the times at which pressure is measured are also scaled by the same ratio. The practical importance of the principle of similarity lies in the economy of effort it permits in determining the properties of shock waves and in the predictions it makes possible in determining the effect of changing the scale

Under the title *Scaling Effects*, Dunkle (Ref 3, p 309) stated that "The most direct experimental test of similarity is the making of two or more experiments with charges of different weights, in which all the corresponding linear dimensions are in the same ratio". A series of measurements was made by Coles (Ref 1) for 50 & 80-lb spherical chges of 50/50 Pentolite (cast) at distances from 12 to 100 ft and they were compared with data for 3.8-lb chges at a distance of 5 ft. The results obt'd are given in Table

Table
Experimental Verification of
Geometrical Similarity for Shock Waves from
Spherical Charges of 50/50 Pentolite

| | | | |
|--|-------|-------|-------|
| Charge Weight, w (lb) | 80 | 14 | 3.8 |
| Distance, R (ft) | 14.0 | 11.9 | 5.0 |
| $\frac{w^{1/3}}{R} \left(\frac{\text{lb}}{\text{ft}}\right)^{1/3}$ | 0.308 | 0.312 | 0.312 |
| Peak Pressure P _m (lb/in ²) | 5910 | 6060 | 6040 |
| Reduced Time Constant $\theta/w^{1/3}$ (μsec/lb ^{1/3}) | 69.6 | 72.8 | 69.7 |
| Reduced Impulse I/w ^{1/3} (lb sec/in ² lb ^{1/3}) | 0.604 | 0.604 | 0.558 |
| Reduced Energy Density, E/w ^{1/3} (inch lb/in ² lb ^{1/3}) | 237 | 263 | 273 |

Another example in which the calculation of charges is of importance is in the determination of demolition charges for particular tasks. Formulas for calculations of charges used in the field by the US Army are listed by Dunkle on pp 309-10. They are taken from the Field Manual, "Explosives and Demolitions", listed here as Ref 2. This Manual has been replaced by Technical Manual listed here as Ref 4

Another application of the principle of similarity is to the calculation of maximum quantities of explosives and numbers of persons allowed in the rooms of any building used for expl operations. The rules to be followed are outlined in the US Army "AMC Safety Manual", AMCR 385-224 (June 1964)

The principle of similarity is also used in evaluation of structures for ammunition manufacture and for calculation of safe distances between the buildings manufg or storing expls, distances to roads, inhabited area, etc

Refs: 1) J.S. Coles, "Summary of Underwater Explosive Comparisons", OSRD 6241 (1946) 2) Anon, "Explosives and Demolitions", FM 5-25 (1954) 3) Dunkle's Syllabus (1957-1958), pp 307-10 4) Anon, "Demolition Materials", TM 9-1375-200 (1964)

Detonation, Shock Wave (or Stress Wave) Fracturing of Metal in. Accdgd to Cook (Ref 4, p 341), Rinehart & Pearson (Ref 1) have considered in detail the fundamental principles of fracturing of metals under *impact loading* by high explosives. Many of the features of fracturing under impulsive loads are directly applicable in rock blasting. Furthermore, one may use metal fracture patterns at close range to deduce the structure of the detonation head. For these reasons some of the observations described in Ref 1 and similar ones observed in Cook's laboratory are summarized on pp 341-47 of Ref 4

When the shock wave reaches a surface of the metal, it is reflected as a tension wave. As the reflected (tension) portion of the wave moves back thru the remaining oncoming compression part of the wave, the compression and tension components add algebraically, i.e., the negative "pressure" of the tension wave adds to the positive pressure of the compression wave. If, and when, the net "pressure" becomes sufficiently negative to equal the tensile strength of the specimen, *scabbing* or *spalling* occurs sharply at the plane where the tensile strength is first overcome. This is the same as "Hopkinson bar spall". If the maximum (positive) amplitude of the compression is (as it reaches the surface) greater than, but less than twice as great

as, the magnitude of the tensile strength of the metal, then only one scab is produced and this occurs within the part of the wave that has not yet been reflected (i.e., at a time before the reflected wave has passed thru the tail of the oncoming compression portion of the wave) (Ref 4, p 342)

Multiple scabbing occurs when the amplitude of the incident compression wave at the instant of reflection exceeds by more than a factor of two the magnitude of the tensile strength of the medium. Then, as soon as the net "pressure" reaches in negative magnitude the tensile strength, *spalling* takes place at that portion of the metal between the original surface and the surface where the tensile strength is first exceeded. *Spalling off* from the metal block occurs at a velocity corresponding to the "trapped" particle velocity of the front part of the shock wave. This uncouples the front portion of the wave from the rest of it, and the part of the wave not yet involved in this original reflection then simply acts independently as a new compression wave. That is, it undergoes reflection at the new surface, and repeats the process of *scabbing* as many times as it still has sufficient amplitude to do so. Multiple scabbing requires a compression wave in which the wave is finite in thickness and in which pressure falls steadily with distance behind the shock front. Scabbing would take place only in the region corresponding to the *release wave* (also known as the *lateral rarefaction wave*), and this probably would not be multiple in the rapidly falling pressure contour outside the flat region. Hence, if the "detonation head impulse" were to maintain its form in the shock wave transmitted into the medium, only a single scab would be produced and it would occur only after the reflected wave had moved into the presumably sharp release wave behind the flat region. This is the condition that generally occurs when the metal plate is not too thick (Ref 4, p 342)

The principles of stress wave fracturing account satisfactorily for the tensile fracturing results described by Hino (Ref 2)

and also by Livingston (Ref 3). Theories of Hino and of Livingston, are described here under "Detonation, Shock-Wave (or Stress-Wave) Fracturing of Rock in". They give deep insight into the mechanism of rock breakage in commercial blasting. Also they show clearly, for example, why it is desirable in borehole blasting to provide conditions whereby the rock may fracture in tension (Ref 4, p 343)

Under the title **Corner Fracturing**, Cook states on pp 343-44, that Rinehart & Pearson (Ref 1) showed that as a shock wave enters a corner it is reflected in the usual manner from the surfaces near the corner and the reflected tension waves therefore must meet along the plane or line (depending on the geometry) frequently causing tensile fracture along the plane or line. If the separate waves are too weak to produce fracture, this might be caused by the combined tension waves. Thus, instead of knocking the corners in chunks (as one might normally expect), there will be cracks running into the block from the corners. This may be done in such a direction to approximately bisect the corner angle, or the corner fracture may be of sufficient magnitude to cause fragmentation with a conical slug knocked off the end of the block. One can use the principle of corner fracture to regulate accurately the nature of the fragments produced in *impact loading* of metals (Ref 4, p 344) (See Detonation, Shock or Impact-Loading of Metals)

Under the title **Fracturing by Release of Load**, Cook (Ref 4, p 344) stated that when a metal block is impacted by a detonation wave from an HE it undergoes some plastic deformation at the explosive-metal interface, or simply compression if pressures are below the plastic deformation regime. The high pressure generated by an expl is of short duration and falls rapidly with distance from the expl-metal interface. When the chge in contact with the metal block is of small diameter and length, the sharp pressure pulse it creates moves impulsively into the metal and creates considerable compression. But as soon as the pressure of expln gases drops,

the compressed region of metal is suddenly released, and the metal then not only comes out of compression, but also this action becomes so rapid that the metal goes into tension. This tension phase may be of sufficient magnitude to produce tensile failure, or it may produce backward scabbing or spalling, or it may simply leave the block with permanent fracture in its interior without spalling. Rinehart & Pearson (Ref 1) described this phenomenon for the case of blocks impact-loaded at the end of short cylindrical charges of a plastic expl (Ref 4, p 344)

Cook & O.K. Shupe (unpublished) have used the principle of fracturing by *release of load* to study the shape and pressure distribution in the *detonation head*. They detonated long cylindrical chges of granulated RDX vibrated uniformly into thin walled paper tubes of various OD's around axially centered mild steel rods. They found that if OD was less than a certain value, the rod acquired as a result of detonation of RDX a linear tension fracture nearly all the way along its cylindrical axis, except for fixed region at the initiation end. This *axial tension fracture (ATF)* zone also was characterized by radial tensile fracture spurs (usually 2 to 4 in number) extending sometimes half way to the surface of the rod. Moreover, the thinner the band of expl, the larger was the tensile fracture zone and spur pattern along the axis of the rod, except for layers of expl of 1/8 inch or thinner where no axial failure was observed. Also in each case, corner fracturing caused a chunk of the rod with a conical rear surface to break off the ends. But for outside chge diams greater than the critical values, no ATF of the metal was produced in the rods. Table 13.10 of Ref 4, p 345, showed that critical OD's in experiments of Rinehart & Pearson (Ref 1) were betw 1.6 and 12.7 cm. Their other findings confirmed the predicted properties of the *detonation head* and showed that the *shock velocity* in steel is ca 10% higher than the *deton velocity* of the granular RDX (Ref 4, p 345)

Under the title **Fracturing by Relative Motion of Load**, Cook (Ref 4, p 346) stated that perhaps the most important type of fracture as far as commercial blasting is concerned is that described by Rinehart & Pearson (Ref 1) as fracture due to "relative radial motion". In their experiments they used large cylindrical blocks contg an axial 1-inch diam chge of plastic expl. By selecting the block large enough that it was not ruptured by the deton of an axial chge, they found (on sectioning the block) a network of radial fractures that neither began at the slightly deformed shot hole, nor the cylindrical surface of the block. For example, with a 9-inch OD cylinder having a 1-inch ID axial hole in which the chge was detonated, the radial cracks began ca 1 inch from the somewhat expanded shot hole and extended ca 1 inch radially outward. With a smaller OD/ID ratio these radial cracks increased in length, number and size until at small enough values of this ratio they became the seat of extensive block fracture and fragmentation. *Fracturing by relative motion* of the load always takes place in cylindrically and spherically expanding burdens whether scabbing or shock wave tensile fractures occur or not

Under the title **Shear Fracture**, Cook (Ref 4, p 346) noted that under conditions in which the tensile forces cannot develop or are restricted, a type of fracturing that can be associated with trajectories of maximum shear stress may develop. Rinehart & Pearson (Ref 1) detonated a 1/8 inch layer of expl on the cylindrical surface of a 2 3/4 inch OD aluminum (24S-T) cylindrical block with a 3/4 inch cylindrical relief hole drilled thru the longitudinal axis. The shock wave moving in toward the relief hole developed at each point of the block two mutually orthogonal trajectories of maximum shear stress. The trajectories, where the shear stress was maximal, spread out in 8 to 12 curved continuous lines from points on the surface of the relief hole. The shear fraction patterns observed along trajectories of maximum shear resembled the "Luder's

lines" appearing in shear stressing of mild steel. The pattern of "Luder's" type lines extended out about a third of the distance from the original relief hole to the cylindrical surface of the block, terminating in tensile fractures that occurred in a cylindrical surface of diameter about half the OD of the block. Another experiment described in Ref 1 involved deton of a 1-inch diam expl in a 1-inch axial hole of a 4-inch diam mild steel block. The sectioned block showed not only the radial cracks associated with relative radial expansion of the block, but also at 14 points around the slightly expanded shot hole, the beginnings of the shear fracture trajectories, each starting at an angle of ca 45° to the surface of shot hole and extending 3-4 mm into the block. The "shear fracture method" has been used in tunnel driving and is known as **Burn Cut Round Method**. Here are drilled relief holes of 2 to 4-inch diameter in a pattern at its center perpendicular to the face of the drift. The whole face then contains a pattern of holes running from the face back into the material to be blasted a fixed distance, say 6 to 8 ft. The angle of each hole is selected based on experience to obtain the best action at each stage of the round. The principle of the relief hole is to allow a free surface into which the initially fired holes of the round are able to break laterally along the drill hole. If successful, the initial loaded holes adjacent to relief hole will break out along most of the lengths of the holes by first breaking to the relief hole, and then by blowing rock out of the hole. This will create an open hole at the center of the drift to which remaining relief holes may break in successive rings by slabbing. The whole round may be fired with a series of delay caps as indicated in Ref 4, p 347 [See also Detonation, Shock Wave (or Stress Wave) Fracturing of Rock in] Refs: 1) J.S. Rinehart & J. Pearson, "Behavior of Metals under Impulsive Loads," Cleveland, Ohio, American Society of Metals (1954) 2) K. Hino, Industrial Explosives Society Japan **15**, 244 (1954) &

17, 1 (1956) 3) C.W. Livingston, "Sixth Annual Drilling and Blasting Symposium", Univ of Minnesota, Oct 1954, p 44 4) Cook (1958) 340-47

Detonation, Shock-Wave (or Stress-Wave) Fracturing of Rock in. Accdg to Cook (Ref 3, p 339), Hino (Ref 1) published studies of the importance of the compressive S_c and tensile S_t strengths and the ratio S_c/S_t on rock fracturing by shock from three Japanese industrial expls: an Ammon Gelatin, a Permitted Ammon Gelatin and an Ammon Dynamite. Their compns are not given by Cook, but the properties are

Table 1

| Properties of Hino's Explosives | | | | |
|---------------------------------|------------------|-------------|---------------|--------------|
| Explosive | ρ_1 g/cc | D, m/sec | Q, kcal/kg | P_2 atm |
| Ammon Gelatin (AG) | 1.45 | 5860 | 1060 | 9.8 |
| Permitted Ammon Gelatin (PAG) | 1.55 | 5250 | 850 | 9.6 |
| Permitted Ammon Dynamite (PAD) | 0.95 | 3320 | 700 | 2.7 |

Hino showed that the thickness l of each slab *spalled* from the end of 4 x 4 cm square block, 30 cm long can be expressed as:

$$l = LSt/2p_a \quad (13.23)$$

where L = length of shock wave and p_a is the peak pressure of the shock at the free face

The number of slabs produced on *spalling* is:

$$N = L/2l = p_a/St \quad (13.24)$$

and the tensile strength is:

$$S_t = 2P/\pi ld \quad (13.25)$$

where P is the breaking load acting along the diameter d , of a cylindrical specimen. Similarly he gave for the compressive strength:

$$S_c = (4P/\pi d^2)(1 - Bd/l) \quad (13.26)$$

where B is a rock constant

From Hino's studies can be drawn the conclusion that Sc of the rock alone determines the shape and pressure of the shock wave that propagates in the rock. But from

eq 13.24 the number of fragments should vary as St^{-1} , and therefore Hino determined the ratio Sc/St and called it *blastability*, B . Table 2 gives results of Hino's investigations

Table 2

| Shape of Shock Wave for Various Rocks and Explosives, and Blastability of Various Rocks | | | | | | | | |
|--|------------------------------|------------------------------|---------|--------------------|-----------------------------|------------|----|-------|
| Rock | Sc , kg/cm ² | St , kg/cm ² | Sc/St | Explosive | Charge Weight (grams) | Shock Wave | | |
| | | | | | | P_a | L | N |
| Marble | 815 | 55 | 14.8 | Ammon Gelatin (AG) | 10 | 275 | 27 | 5-5 |
| " | " | " | " | " | 20 | 275 | 28 | 4-5 |
| " | " | " | " | " | 30 | 275 | 37 | 3-4-5 |
| " | " | " | " | Permitted AG | 10 | 275 | 29 | 4-5 |
| " | " | " | " | Permitted AD | 10 | 220 | 26 | 3-4 |
| Granite | 1000 | 75 | 13.3 | AG | 10 | 375 | 29 | 4-5 |
| " | " | " | " | PAG | 10 | 375 | 28 | 3-4-5 |
| " | " | " | " | PAD | 10 | 300 | 32 | 3-4 |
| Sandstone | 1700 | 110 | 15.5 | AG | 10 | 550 | 28 | 4-5 |
| " | " | " | " | PAG | 10 | 550 | 29 | 4-5 |
| " | " | " | " | PAD | 10 | 550 | 28 | 3-4-5 |

Livingston (Ref 2) has also considered the influence of shock waves in rock on the mechanics of rock failure in blasting. While Hino's work dealt with one-dimensional effects (from which general conclusions concerning two- and three-dimensional fracturing could be deduced), Livingston's observations, in which he studied cratering, were actually more directly applicable to blasting because he employed actual bore-hole conditions. He observed fracturing along "O-cracks" around the cylindrical blast hole, corresponding to Hino's slabs, although the expected inner rings may be obliterated and only the last "O-cracks" may be evident in Livingston's method. In addition, Livingston observed so-called radial "R-cracks" that result only in two- and three-dimensional wave propagation. He considered the partition of energy in

fragmentation as a function of the depth ratio $\Delta (=d_c/N$, where d_c is the charge depth and N the critical depth below which no visible damage of the surface was seen in his cratering experiment). The *strain energy factor* E was defined by the equation:

$$E = N\omega^{-1/3}$$

where ω = weight of explosive and the crater volume V as:

$$V = E^3\omega ABC$$

where A is an energy utilization number, B is a rock-fragmentation number and C is a stress-distribution number. Livingston also defined the ratio V/ω as a *volume utilization factor* and determined it from the last equation:

$$V/\omega = E^3ABC$$

He used this factor as a basis for selecting the explosive with respect to cost and desirability (Ref 3, pp 340-41)

There have been accdgs to Cook, various other attempts to place blasting on a more scientific basis, but we have no information more recent than Cook's book

Refs: 1) K. Hino, Industrial Explosive Society Japan **15**, 244 (1954) & **17**, 1 (1956)
2) C.W. Livingston, Sixth Annual Drilling and Blasting Symposium, Univ of Minnesota, Oct 1956, p 44 3) Cook (1958), 339-41

Detonation, Shooting Test in. See Ref 65 under "DETONATION (AND EXPLOSION), EXPERIMENTAL PROCEDURES"

Detonation, Sideways Expansion in. See Detonation, Lateral Expansion (Dispersion) and Lateral Loss in". Called by G.B. Kistiakowsky "radial expansion"

Detonation, Skid Test in. See under "DETONATION (AND EXPLOSION), EXPERIMENTAL PROCEDURES"

Detonation, Slow, Same as "Low Order Detonation", described under "Detonation; High-, Low-, and Intermediate-Order - Velocities of"

Detonation in Slurry Explosives. Cook, in his book, pp 316-21, described under the heading "Water-Compatible Explosives" properties of *slurry explosives* developed by M.A. Cook & H.E. Farnam. These expls were intended for use in large diameter underwater blasting at Iron Ore Company of Canada's Knob Lake operation. The success of these expls brought out the importance of pressure and density on the products of detonation. Table 12.21 of Cook's book gave computed properties of three dry versus water soaked slurry mixtures at AN/TNT ratios of zero, 1.0 & 3.25. It was of interest to note that the computed (dry basis) available energy A of the TNT in slurry with 27% water was 17% greater

and the explosion pressure, p_3 , 57% greater than for the corresponding dry, low density TNT. Likewise at AN/TNT = 1.0 the dry basis A was 5% higher and p_3 56% higher for the slurry than for the corresponding dry mixt. Table 12.22 showed that deton velocity $D=4080$ m/sec of dry TNT of density 1.03 could be increased to as high as 5990 m/sec by slurring with as much as 38% of water. Table 12.23 (p 318) gave properties of AN slurries of small critical diameter. Table 12.24 (p 319) gave props of AN slurries of maximum AN content for large diameter blasting. Table 12.25 (p 320) gave limits of water contents of AN/Al mixtures detonating in charges of 4-inch diameter and 24 inches long. Table 12.26 (p 320) gave final density and water contents of various An-Al-Coarse TNT mixtures poured into 50/50 AN/Water

Detonation of Smokeless Propellants was discussed by T. Urbański in SS **34**, 103-05 (1939)

Detonation (and Explosion) in Solid Explosives. See Detonation (and Explosion) in Condensed (Liquid and Solid) Explosives

Detonation, Sound Speed Frozen in. Under the heading "Chapman-Jouguet Detonation with Varying Product Composition; Frozen Sound Speed", Evans & Ablow (Ref 4, pp 150-51) stated the following:

"Now the assumption is dropped that the chemical reaction is a rate-controlled conversion to an invariant product composition, and the composition is permitted to vary with local thermodynamic state. Zel'dovich, Brinkley & Richardson, and Kirkwood & Wood pointed out that since in a chemically reactive wave, pressure is a function not only of density and entropy but also of chemical composition, the sound speed for a reacting material should be defined as the *frozen sound speed*

$$\bar{c}_2 = \left(\frac{\partial p}{\partial \rho} \right)_{S, \lambda} \quad (4.3.1)$$

where λ denotes a set of variables, λ^j , which specifies the progress of j reactions occurring within the reaction zone. Then the rarefaction wave which adjusts the steady zone to the rear boundary must move with the speed c_2 defined by equation 4.3.1, with appropriate values of λ and S "
Note: λ =reaction progress variable and S =specific entropy

The treatment of Kirkwood & Wood is given on p 151 of Ref 4.

Refs: 1) Ya.B. Zel'dovich, *ZhEksper i TeoretFiz* **10**, 542(1940); Engl transl in NACA TechMemo **1261**(1950) 2) S.R. Brinkley Jr & J.M. Richardson, 4thSymp-Combstn (1953), pp 450-57 3) J.G. Kirkwood & W.W. Wood, *JChemPhys* **22**, 1915-19(1954) 4) M.W. Evans & C.M. Ablow, *ChemRev* **61**, 150-51(1961)

Detonation (and Explosion) in Space.

Under the German title "Raumexplosionen" are discussed explosions taking place in large volumes, such as in rooms, chambers, etc. See Refs

Refs: 1) H.H. Freytag, "Raumexplosionen durch elektrische Anlagen", VerlagChemie, Zürich(1949) 2) H.H. Freytag, "Handbuch der Raumexplosionen", VerlagChemie, Weinheim/Bergstr (1965), 664 pp

Detonation, "Space Catalysis Phenomenon" in. See under "Detonation Velocity, Influence of Aging of Gelatin Explosives on"

Detonation, Spalling and Scabbing of Solids by Shocks. *Scabbing* is the breaking off of fragments in the inside of a wall of hard material due to impact or explosion of a projectile on the outside. The preferred term is *spalling*, which refers to fragments torn from either surface of armor plate, such as might result from the impact of kinetic energy ammunition, or the functioning of chemical energy ammo

See also under "Detonation, Shock Wave (or Stress Wave) Fracturing of Metal in" and "Detonation, Shock Wave (or Stress

Wave) Fracturing of Rock in"

Refs: 1) J.S. Reinhardt, *JApplPhys* **22**(5), 555-60(1950) (Some quantitative data bearing on the scabbing of metals under explosive attack) 2) K.B. Broberg, *JApplMech* **22**, 317-23(1955) (Scabbing of solids under explosive attack) 3) E.B. Dally, "Spalling Experiments in Mild Steel", Poulter LaboratoriesIntRept **037-56**(1956) 4) S. Kumar, "Scabbing and Pulse Propagation in Materials", PennStateUniv **ITR-14** (Aug 1958) 5) Cook (1952), pp 339, 342 & 343 6) J.O. Erkman, "Decay of Explosively-Induced Shock Waves in Solids and Spalling of Aluminum", 3rdONRSymp-Deton (1960), pp 253-66 7) M.L. Wilkins, "Calculation of Spall Based on One-Dimensional Model", International Symposium "Les Ondes de Détonation", CNRS (1961), pp 459-68 8) OrdTechTerm (1962), pp 265 & 283

Detonation, Specific Impulse in. See Detonation (and Explosion); Impulse, Specific in

Detonation (and Explosion), Spectra and Spectrographic Measurements in.

Studies have been made for determination of spectra produced by flames, shock waves and detonation waves and spectrographic measurements have been made for approximate determination of temperature developed on detonation (or explosion). We call this *temperature of detonation*, while the term "detonation temperature" we reserve for the "temperature required to cause a detonation"

Various spectrographic methods are described in Refs. Harris (Ref 4) recommended an image-orthicon spectrograph and an image-converter spectrograph, Dunkle (Refs 7 & 11) and Cook (Ref 8) mentioned several methods and listed refs
Refs: 1) J.G. Fox, "Spectrographic Measurement of Detonation Temperature", *NavOrd* **200-45**(1945) 2) I.F. Henning, "Temperaturmessung", J.A. Barth, Leipzig (East Germany) (1951) 3) J.H. Hett & J.B. Gilstein, "A Study of Techniques for the Measurement of Detonation Spectra and

Temperatures", Final Rept, Research Division of NY Univ, Contract **DA-30-069-ORD-945**, May 1953 4) F.S. Harris Jr, "The Measurement of Temperature of Explosives", Tech Memorandum No 1, Contract **N7-onr-45107**, Project No 357239, ERG, Univ of Utah, Aug 1953 (122 refs) 5) C.M. Mason & F.C. Gibson, "Research Program on Detonation and Explosives Phenomena", USBurMines Progr Rept **9** (July-Sept 1955) 6) A.R. Fairbairn & A.G. Gaydon, "Comparison of the Spectra Produced by Shock Waves, Flames and Detonations", *Nature* **175**, 253-54 (1955) 7) Dunkle's Syllabus (1957-1958), pp 305-06 8) Cook (1958), 38 (Spectrographic methods for determination of temperature of detonation) 9) Baum, Stanyukovich & Shekhter (1959), 97 (Spectroscopic method of Alentsev & Belyaev, proposed in 1945 for determination of flame temp of expls) 10) Andreev & Belyaev (1960), 429 (Spectrographic method of A.Ya. Apin & I.M. Voskoboinikov for detn of temp of deton) 11) Dunkle's Syllabus (1960-1961), pp 25a & 25b (Spectrographic methods) 12) V.A. Dement'ev & V.N. Kologrivov, *ZhFizKhim* **36**, 458-62 (1962) & *CA* **57**, 1141 (1962) (Detn of emission spectrum in the detonation of a solid explosive in a vacuum) 13) R. Stoops, Edit, "Energy Transfer in Gases", Interscience, NY (1963) (Solvay Inst 12th Chemistry Conference held at Brussels University 5-11 Nov 1962) (See Spectra in deton)

DETONATION (EXPLOSION AND COMBUSTION), SPHERICAL (Spherical Blast, Spherical Front and Spherical Wave). Spherical detonations (explosion and combustion) are those in which initiation in the center of a charge (preferably spherical in shape) will cause formation of spherical shock and detonation waves. These waves move radially away from the charge into the surrounding medium (gaseous, liquid or solid) in such a manner that particles of their outer boundary (front) are always equidistant from the center of the charge in the manner shown in Fig on p 183 of Vol 2 of Encycl

The method of initiation from a small spot by a small object (such as an electric primer, a blasting cap or a strong electric spark) may be called *point initiation* and the explosion produced by such method is known as a *point source of explosion*. It is called "rochechnyi vzryv" in Russian and its theory is discussed in detail in the book of Baum, Stanyukovich & Shekhter (Ref 20). Accordg to them, point explosion is the simplest case of action of shock wave, where it is assumed that the mass of products of explosion is infinitely small, but quantity of energy evolved by the charge is finite. In investigation of point explosion it is sufficient to study the action of shock waves. This study is easier than study of real explosion, but formulas obtained from the theory of point explosion can be applied (with some modifications) to real explosions, both *spherical* and *cylindrical*. Point source explosion was also described by Brode (Ref 14) and Korobeinikov (Ref 16)

The simplest method for producing a spherical combustion in gases is to place a combustible (but not explosive) gaseous mixture in a thin latex, rubber or plastic balloon and ignite it in the center by means of an electric spark

Spherical combustion waves are described in the book of Lewis & von Elbe (Ref 23) and recently investigated by Plickenbaum et al (Ref 25). It was found that such waves are not affected by flow interactions with solid surfaces, and therefore require longer run-ups for transition to detonation

In the overdriven state, the observed propagation velocity of the combustion front was found to be much higher than the steady-state velocity of spherical detonation. The overdriven state exists for only a short time, and the combustion front velocity then drops rapidly to the steady-state value. The rate at which this exceedingly high velocity decreases was found by experiment to be inversely proportional to the induction distance

The high flame front velocities prior to attainment of the steady state probably result from the transient conditions between the combustion front and shock front. Sufficient data were lacking to show whether the shock-heated gas ignited spontaneously, immediately behind the shock front, or whether the flame front overtook the shock front. In any event, the combustion wave finally moves along with the shock wave, thus forming a detonation wave

The instant at which combination of the combustion and shock waves begins is not necessarily the point at which the steady-state detonation velocity has been reached. Because of the turbulence generated by the flame, the velocity of the products relative to the initially forming detonation front may be subsonic. This state cannot last very long because rarefaction waves thru the burnt gas can move right up to the detonation wave and weaken it until its speed drops to unit Mach number relative to the products

If the detonation wave is formed not by spontaneous ignition behind the shock wave but by a sudden rise in combustion wave velocity, a higher than normal detonation velocity could still be observed. In this case, almost instantaneous ignition occurs in all of the unburnt gas behind the shock front, beginning at the flame front. The gas between the flame and shock fronts has been heated and compressed by pressure waves generated by the expansion of the burnt gas. At any moment during the initiation period, the temperature and pressure in this region are highest just ahead of the combustion front and lowest directly behind the shock. Therefore, it is plausible that the reactions here become so rapid that all of this gas burns almost instantaneously (Ref 28)

Spherical combustion was also discussed by Taylor (Ref 5)

Spherical blast waves in air, water and earth are discussed in Vol 2 of *Encycl*, pp B182 & B183 and in Refs 7, 8a, 8b, 8c, 10, 17 & 18 listed below

Spherical detonations in gases were

studied by many investigators and the earliest work on that subject observed by us was that of Prof P. Laffitte (Ref 1). He described spherical detonations of $\text{CS}_2 + 3 \text{O}_2$ mixtures

Manson & Ferrié (Ref 6) investigated explosive mixtures consisting of combustible hydrocarbons such as C_2H_2 , C_2H_8 and natural gas with oxygen as oxidizer. The mixtures were placed in transparent round latex flasks. Initiation was in the center. With their method, it was possible to record spherical detonation waves whose velocities were the same as when these mixtures were detonated in tubes. The waves usually originated very near the ignition source (electric spark or electric primer), but in some cases there was a brief predetonation period

Freiwald & Ude (Ref 9) demonstrated by means of optical methods the spherical expansion of the detonation in mixtures of acetylene and air in various proportions, placed in rubber balloons of capacities 90 to 2500 liters and initiated in the center. After the detonation had taken place, the multiple flattening out of reflected spherical waves was observed

In the later work, Freiwald (Ref 16) photographed by a rotating drum camera, spherical detonations in mixts of acetylene, ethylene, propane and hydrogen with air, oxygen or oxygen-nitrogen mixtures. The mixts were placed in large rubber balloons and initiated either by a blasting cap, spark, or by a detonation wave introduced in the center of the balloon by a tube. The detonation velocity observed for 12.5% acetylene-air was 1980 m/sec. Shock waves in the burnt gases were observed after passage of the detonation waves. In all cases these shock waves followed the same pattern. First a shock wave traveled from the balloon surface to the center. After coming together at the center, the shock wave expanded outward and disappeared. A short time later the appearance of a new shock wave at the center was observed. The origin of the 2nd shock wave was discussed in the analogy to detonation

in spherical solid expls. After its appearance, the 2nd shock wave expanded out from the center and was reflected from the air-burned gas interfaces back to the center again

In another paper Freiwald & Koch described (Ref 24) investigation of spherical detonations of acetylene-oxygen-nitrogen mixtures as a function of nature and strength of initiation

Zel'dovich & Kompaneets (Ref 21) stated that the values of steady velocities of spherically propagating detonation waves in gaseous explosions are the same as the values measured in tubes at corresponding mixture ratios

Spherical detonation in gases were discussed also in Refs 11, 12, 17, 19 & 20

Baum, Stanyukovich & Shekhter (Ref 20) gave a rather comprehensive discussion on spherical detonations and following are some high points of this discussion:

Immediately after initiation of a spherical charge and formation of products of explosion, a shock wave forms. The pressure of products moving away from the charge will fall quicker (on expansion) than in the shock wave. Impact of this shock wave and of the products of explosion against the surrounding air will cause formation of pressure (compression) wave. This wave will move in opposite direction to the products of explosion and it might transform, in some cases, into a 2nd shock wave. In any case this wave will start to equalize the pressure in the products of expln. Then it will encounter, as it moves, smaller and smaller resistance from the products of expln and at the distance of the order $10r_0$ (where r_0 is the radius of charge), products of explosion will practically stop moving, since ca 90% of their energy will be dissipated in the atmosphere. At this stage all the above mentioned waves will start to level off the gradients of pressure in the products of expln. This action will be completed after the rarefaction wave (formed at the beginning of dispersion of products of detonation at the surface of the charge)

arrives at the center of the chge and reflects from it. Then it will go to the boundary dividing products of expln from the shock wave and will reflect at the intersection with it. This is usually located at the distance of 3 to $4r_0$ from the center of the charge. It was mentioned above that about 90% of energy of products of expln is lost on detonation, but the experimental determinations showed that the energies of air moving forward (away from the center of the chge) and of the shock wave have only 60-70% of total energy of expln. The difference between 90% and 60-70% is lost because the process of expansion of products of expln is not stationary and the boundary between the products and the shock wave is in a state of vibration. These vibrations are actually secondary shock waves which become weaker and weaker until they resemble an ordinary sound wave. Energy required for producing these vibrations is ca 20-25% of total energy of explosion (Ref 20, pp 624-25)

Further in the book of Baum et al (Ref 20, pp 625-40) is given a mathematical treatment for determination of pressure of shock wave and of products of explosion at different distances from the center of the charge. The formulas derived on 15 pages of the book would take too much space if included here

Spherical detonation waves can also be produced by condensed expls (solid or liquid), especially if the charges are spherical in shape and they are initiated in the center. The above discussion of Baum et al applies to both gaseous and condensed expls. Addnl information on spherical detonation of solid explosives can be obt'd from the works of Landau & Stanyukovich (Ref 2), Jones & Miller (Ref 3), Wecken & Muecke (Ref 4a), Lutzky (Ref 26), Rudlin (Ref 26a) and Green & James (Ref 27)

Accd'g to Dunkle (Ref 28), Brode (Ref 14), in order to solve detonation problems without recourse to empirical values derived from explosion measurements, integrated the hydrodynamical equations of motion (which constitute a set of nonlinear partial

differential equations) by a numerical procedure on a high-speed electronic computer. The propagation of shock discontinuities was handled by a common form of the artificial viscosity technique of von Neumann & Richtmyer (Ref 4) similar to the method used later by Brode (Ref 10). The initial conditions were taken as approximately those of the centered detonation of a bare sphere of TNT of loading density 1.5 g/cc as specified by the detonation wave descriptions of Taylor (Ref 5). The equation of state of TNT was modeled after that of Jones & Miller (Ref 2), while the equation of state of air was a fit to computed data of several investigators but primarily that of Gilmore (Ref 11) and of Hilsenrath & Beckett (Ref 12). As the results of calculation by Brode, the pressures, densities, temperatures and velocities were detailed as functions of time and radius. Space-time relations, and energy & impulse histories were shown. A second shock was seen to originate as an imploding shock following the inward rarefaction into the explosion product gases and a series of subsequent minor shocks were seen to appear in a similar manner, moving out in the negative phase behind the main shock.

Discussing the analysis of spherical detonation in TNT, Lutzky (Ref 26) noted that, as described in Cole (Ref 3a), H. Jones developed an equation of the Grüneisen type, based on the Einstein model of a solid, of the form $p = Ae^{-av} - B + fRT$, where a , A , B and f are constants. Lutzky, however, preferred to use an equation based on the discussion by Zel'dovich & Kompaneets (Ref 21) of the equation derived by Landau & Stanyukovich (Ref 2). In their view, the comparatively stable molecules of the detonation products are in a highly compressed state, being at a density over twice that of the liquid gases. The predominant part of the pressure is due to elastic repulsion. To hold the molecules at this density requires a large external pressure. The thermal part of the pressure is contributed by thermal fluctuations of the molecules about their equilibrium positions. These fluctua-

tions together with oscillations of the atoms in the molecules give the thermal part of the energy

The dependence of the elastic pressure on the density can be expressed approximately by a power function $p = B\rho^n$, usually called *polytropic*. It could alternatively be considered that the force centers are repelled according to the relationship $F = a/(3n-2)$ as assumed in the Bohr theory of crystal lattices. The thermal motion, at this degree of compression, consists of small oscillations. To each vibrational degree of freedom there corresponds an energy RT (per mole). The total oscillatory energy equals $c_v T$, where c_v is independent of the volume in this approximation.

The total energy is calculated in terms of the ratio γ of the thermal part of the pressure to the elastic part, and other variables. Isentropic processes are discussed, and the initial conditions of a Landau-Stanyukovich-Zel'dovich-Kompaneets (LSZK) detonation are obtained in terms of γ .

The detonation wave is considered to consist of a shock traveling at speed D , followed immediately by a region of isentropic expansion. The region of chemical reaction behind the shock is considered infinitely thin. From the Rankine-Hugoniot (R-H) relations at the shock,

$$v_0/v = D(D-u). \quad (1)$$

From the Chapman-Jouguet condition

$$D = u + c, \quad (2)$$

equation (1) becomes

$$v_0/v = u/c + 1. \quad (3)$$

Another R-H relation yields

$$P = Du/v_0, \quad (4)$$

which may be written in the form

$$(u/c - 1) u/c = P v_0/c^2 \quad (5)$$

By further manipulation v_0/v is found as a function of γ , and finally D is found as a function of v_0 , consistent with the experimental finding for solid explosives

Three undetermined parameters which appear in the LSZK equation of state are evaluated from the experimental data, and the remaining constants required are evaluated from the experimentally determined dependence of detonation velocity on density

Detonation velocities calculated for densities of 0.73-1.80 are compared with those determined at Bruceton. Values calculated for TNT from the LSZK equation of state at densities of 1.00-1.625 are given for the following detonation parameters: P , E , ρ_0 , u , D , T and the ratio $P_{(\text{elastic})}/P_{(\text{total})}$. Values of ρ_0 , P , u and D are compared with the experimental values reported by Dremin et al (Ref 23a)

The data show that the ratio of elastic to total pressure is higher, the higher the loading density. Thus, near the C-J state, the LSZK isentrope may be approximated by a polytropic relation with exponent 2.78, in agreement with Deal's experimental value of $\tau=2.77$, at least down to 500 bar. The LSZK equation thus seems to yield not only the proper $D-\rho_0$ relationship but also the proper isentrope, both near the C-J state and in the large low-pressure low-density expansion limit

Calculations of the flow field behind the detonation shock were carried out on an IBM-7090 electronic computer for TNT at initial densities of 1.625, 1.59, 1.45, 1.30, 1.14 and 1.00 g/cc and are presented in six tables as functions of a dimensionless distance x/r , r being the radius of the original charge. It is noted that the parameters vary in the well-known way first demonstrated by Taylor (Ref 5) with the region of constant state surrounding the origin

For evaluation of the temperature, c_v must be known. If it is taken to be 0.3 cal/g, an approximate average value for the detonation products, the C-J temperature for $\rho_0=1.625$ g/cc turns out to be 582.9°K, which seems far too low. This is consistent with the decreasing importance of the thermal pressure with increase in ρ_0 , with the resistance of TNT to detonation at high densities (See *Detonation, Resistance to*) and with Deal's results, it is not yet cer-

tain whether the effect is real or just an expression of the incompleteness of the LSZK theory. According to Jacobs, a re-interpretation of the partition between elastic and thermal energy leads to a theory which does not involve a limiting density or vanishing thermal pressure. This theory retains the LSZK form for the equation of state, but does not make use of Zel'dovich's meaning of c_v . In any case, in applications where the temperature is not needed, and only an (E,p,v) equation of state is required, as in calculation of the nonreactive isentropic expansion of the detonation products by means of hydrodynamic computer codes, the LSZK equation of state may be used with confidence. Possibly its correctness cannot be determined by experimental observations of the detonation process alone. A possible approach would be based on the results for the distribution behind the front as initial conditions for a hydrodynamic code calculation of the detonation of a sphere of TNT in air, with use of the LSZK equation of state for the expanding products (Ref 28)

See also Detonation, Spherical Taylor Wave in

Refs: 1) P. Laffitte, CR **177**, 178 (1923) & AnnPhys **10**(IV), 645 (1925) (Spherical detonations of $\text{CS}_2 + 3 \text{O}_2$ mixture) 2) L.D. Landau & K.P. Stanyukovich, DoklAkadN **46**, 399 (1945) (On the study of detonation in condensed explosives) 3) H. Jones & A.R. Miller, PrRoySoc **194A**, 480-507 (1948) (The detonation of solid explosives: The equilibrium conditions in the detonation wave-front and the adiabatic expansion of the products of detonation) 3a) Cole, Underwater (1948), pp 81-83 4) J. von Neumann & R.D. Richtmayer, JApplPhys **21**, 232 (1950) 4a) F. Wecken & L. Muecke, Saint Louis Research Laboratory Report No **8/50** (1950) (Detonation of spherical charges) 5) G.I. Taylor, PrRoySoc **200A**, 235-47 (1950) (The dynamics of combustion products behind plane and spherical detonation fronts) 6) N. Manson & F. Ferrié, "Spherical Detonation Waves", 4thSympCombstn (1952) & CA **49**, 6608 (1955) 7) J.A. McFadden,

- "Initial Behavior of a Spherical Blast", US NOL NavOrdRept **2378**(1952) 8a) F.J. Berry & M. Holt, "The Initial Propagation of Spherical Blast", Part I, "Polytropic Explosives", ARE Rept **6/54**(1954) & PrRoy-Soc **224A**, 236 & 251(1954) 8b) F.J. Berry, D.S. Butler, & M. Holt, Ibid II, "The Early Development of Spherical Blast from a Particular Charge" 8c) M. Holt, Ibid III, "The General Properties of the Singularity of the Origin of Blast", ARE Rept **33/54**(1954) 9) H. Friewald & H. Ude, Explosivst **3**, 116-18(1955) (On the spherical expansion of the detonation in mixtures of acetylene and air) 10) H.L. Brode, JApplPhys **26**, 766(1955) (Numerical solutions of spherical blast waves) 11) F.R. Gilmore, "Equilibrium Composition and Thermodynamic Properties of Air at 24000°K", The Rand Corporation, Research Memorandum **RM 1543**(1955) 12) J. Hilsenrath & C.M. Beckett, "Thermodynamic Properties of Argon-Free Air", NatlBurStdsRept **3991**(1955) 13) E.J. Andriakin, DoklAkadN **111**, 554-56(1956) (Problems related to a heavy explosion, close to spherical) 14) H.L. Brode, "Point Source Explosion in Air", The Rand Corporation, Research Memorandum **RM-1824**(1956) 15) V.P. Korobeinikov, DoklAkadN **111**(3), 557-59(1956) (Appr formulas for calcn characteristics of a shock wave front in the case of *point explosion* in a gas) 16) H. Friewald, ZeitElektrochem **61**, 663-72(1957) & CA **52**, 2910(1958) (Spherical detonation) 17) Dunkle's Syllabus (1957-1958), 97-8 (Spherical shock waves); 177 (Refs for spherical blast) 18) H.L. Brode, "A Calculation of the Blast Wave from a Spherical Charge", The Rand Corporation, **P-975**(1958) 19) Cook (1958), 99-106 (Detonation wave front) 20) Baum, Stanyukovich & Shekhter (1959), 598-624 (*Teoriya tochechnago vzryva*) (Theory of point source explosion); 624-40 (*Sfericheskkii vzryv*) (Spherical explosion) 21) Zel'dovich & Kompaneets (1960), Sections 19, 20 & 23, pp 206, 228 & 279 22) Andreev & Belyaev (1960) (Nothing on spherical detonations) 23) Lewis & von Elbe (1961), pp 512ff (Spherical combustion) 23a) A.N. Dremin et al, 8thSymp-Combstn (1962), pp 610-19 24) H. Friewald & H.W. Koch, "Spherical Detonations of Acetylene-Oxygen-Nitrogen Mixtures as a Function of Nature and Strength of Initiation", 9thSympCombstn (1963), pp 275-81 24a) L. Rudlin, "Origin of Shock Waves from Spherical Condensed Explosives in Air", NOLTR **63-220**(1963) 25) J.W. Plickenbaum et al, Combustion & Flame **8**(2), 89-96 (June 1964) (Propagation of spherical combustion waves) 26) M. Lutzky, "The Flow Field Behind a Spherical Detonation in TNT, Using the Landau-Stanyukovich Equation of State", US NOL-White Oak NOLTR **64-40** (Dec 1964) 27) L.G. Green & E. James Jr, "Radius of Curvature Effect on Detonation Velocity", 4th-ONRSympDeton (1965), pp 86-91 (The effect of the radius of curvature of the detonation front on the detonation velocity of certain explosives were measured. The results were used to calculate the reaction zone thicknesses for various expls. For example, such thickness was found as 0.064 mm for 85/15-HMX/Viton, using Holston HMX, whereas for the same type plastic-bonded expl made from British Bridgwater HMX it was 0.182 mm) 28) C.G. Dunkle, private communication, Nov 1968
- Detonation, Spherical Taylor Wave for the Gaseous Products of Solid Explosives in.** Accdg to Lutzky (Ref 5, p 1): "To investigate the effects of the detonation of a solid explosive charge immersed in a fluid, it is necessary to know the conditions existing in the gaseous explosion products at the instant the detonation wave reaches the surface of the explosive charge. For the case of a spherical charge, this problem has been investigated by G.I. Taylor (Ref 1), who has given a method of finding the mechanical and thermodynamic parameters behind the shock as functions of position and time. This solution is known as the **Taylor Wave**"

Using the methods of Taylor's analysis as the basis of machine computation, Lutzky has computed "Spherical Taylor Wave" for several high explosives (TNT, Pentolite, 65/35 & 60/40-Cyclotols, TNEtB, RDX, Tetryl and NGu) with the equation of state:

$$E = \frac{Pv}{\gamma-1} \quad (\text{or } E = \frac{P}{\rho(\gamma-1)})$$

where E=internal energy per unit mass; P=pressure; v=specific volume; ρ =density; γ =effective ratio of specific heats for the gaseous explosion products. This equation of state with constant $\gamma=3$, has been previously used with some success for the gaseous products of condensed explosives by several investigators. Their results are described in Refs 2, 3 & 4

The calculations of the Taylor Wave were carried out by Lutzky on the IBM 704 computer at NOL. Because the equations used by Lutzky are of slightly different form than those used in Taylor's original calculations (Ref 1), there is given in Ref 5, Section 2, a brief summary of the derivations and some general remarks about the Taylor Wave. Section 3 presents the results as computed by this program using two different forms. Finally, in Section 4, a description of machine program is given

The results of computer calculations of pressure, sound velocity, specific volume, radius, energy, particle velocity, and zone mass for TNT, etc are presented in Tables 1 to 8 on pp 10-18 of Ref 5

A calculation to check the energy conservation has been made, using the data of Tables 1 to 8 and the total energy (internal plus kinetic) has been computed for each zone. The sum of energies over all zones has been compared to the accepted heat of detonation for the specific explosive under consideration. The heat of detonation has been independently computed assuming the Brinkley-Wilson mechanism; that is, by assuming that the available oxygen in the explosive is used to form H₂O (gas), CO, and CO₂ in that order. For Pentolite, it has been assumed that TNT & PETN react independently

Table

| Comparison of Detonation Velocity Calculated by Brinkley-Wilson Mechanism With Total Energy Determined by Computer | | |
|--|-----------------------------|-----------------------|
| Explosive | Heat of Detonation cal/gram | Total Energy cal/gram |
| TNT | 984 | 995 |
| Pentolite | 1200 | 1119 |
| TNEtB | 1446 | 1464 |

In Appendix I, Lutzky stated that it is instructive to display the Taylor Wave in the form of a space-time diagram (See Fig 1). Since all of the dependent variables are functions only of the quantity r/t , as was shown by Taylor (where r is distance and t is time), constant values of these variables are propagated along straight lines in the ($r-t$) plane, fanning out from the origin. This space-time diagram resembles the analogous space-time diagram for the case of a linear detonation shock (shown in Ref 2, p 5), except that there is one difference between the two cases. In the linear case, there is a simple wave in the fan-like region, which means that each radial line is a characteristic line and for each radial line,

$$\frac{r}{t} = u + c$$

where u and c are the constant values of sound and particle velocity carried on the given line

In the *spherical* case, however, there is no simple wave, but for each radial line within the fan-like region, there is:

$$u + c < \frac{r}{t}$$

while only for the two lines that bound the wedge (marked I and II in Fig) the sum $u+c$ is equal to r/t . In fact, the straight radial lines in the spherical case are not, in general, the characteristic lines, as they are in the linear case. The resemblance between the two cases is due solely to the fortuitous fact that in the spherical case (and incidentally also in the cylindrical case) the partial differential equations

of motion and continuity (shown on p 2 of Ref 5) can be reduced to ordinary differential equations (shown on p 3) by using the variable r/t

Refs: 1) G.I. Taylor, PrRoySoc **200A**, 235-47 (1950) (The Dynamics of the Combustion Products Behind Plane and Spherical Detonation Fronts in Explosives)
 2) S.J. Jacobs, "The Energy of Detonation", NavOrdRept **4366** (1956) 3) W.E. Deal,

Physics of Fluids **1**(6), 523 (1958) (Measurement of the Reflected Shock Hugoniot and Isentrope for Explosive Reaction Products) 4) D. Price, ChemRevs **59**(5), 801-25 (Oct 1959) (Measurement of the Reflected Shock Hugoniot and Isentrope for Explosive Reaction Products) 5) M. Lutzky, "The Spherical Taylor Wave for the Gaseous Products of Solid Explosives", NavWeps Rept **6848** (1960)

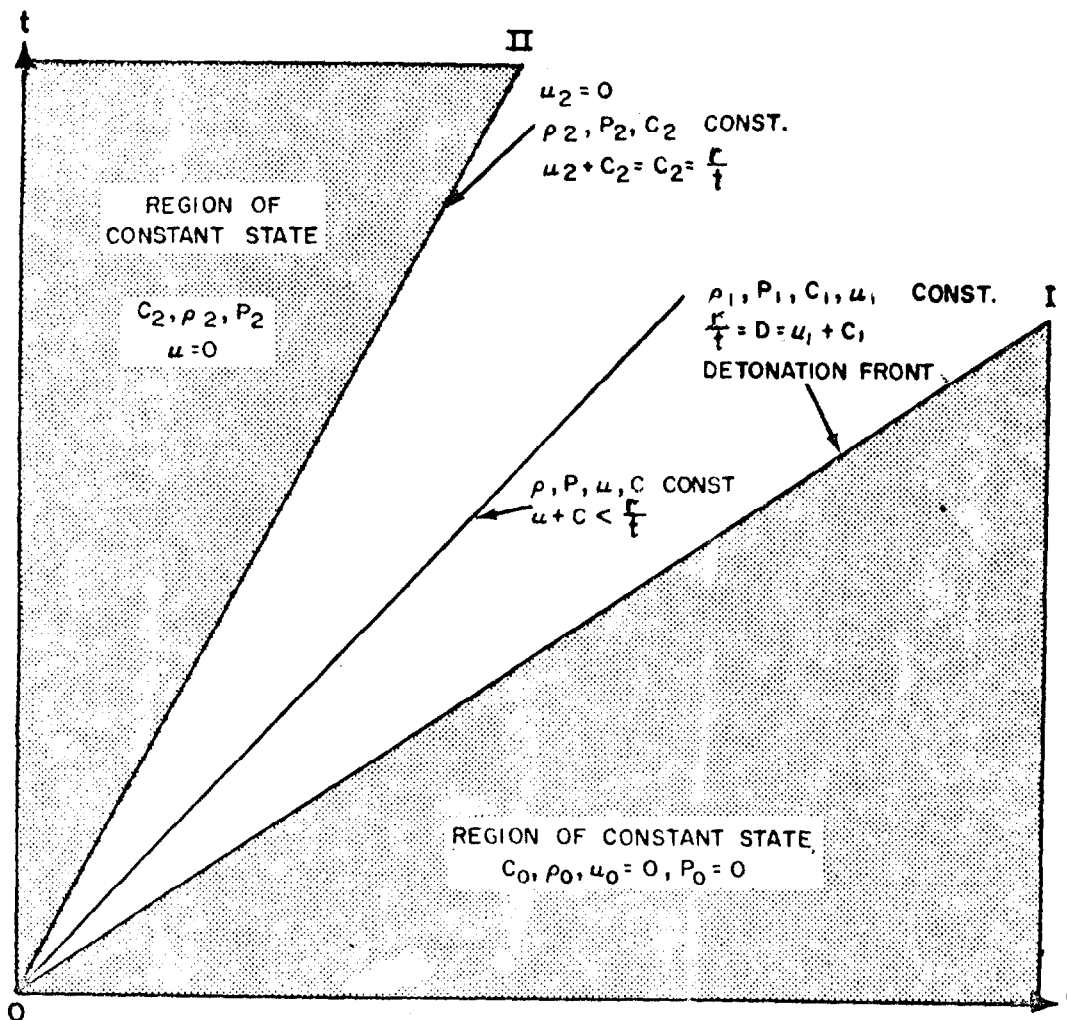

FIG 1 SPACE - TIME DIAGRAM OF THE SPHERICAL TAYLOR WAVE

Detonation, SPHF Plate Test. See under DETONATION (AND EXPLOSION), EXPERIMENTAL PROCEDURES and also Ref 47 under DETONATION (AND EXPLOSION) BY INFLUENCE

Detonation, Spike Pressure and Spike Theory.

Accdg to Dunkle (Ref 6), "spike" is a part of classical hydrodynamic theory which Cook (Ref 2, p 68) and also Evans & Ablow (Ref 4) call Zel'dovich-von Neumann-Doering Model, abbreviated as ZND Model. It is described by us as Detonation, NDZ (Neumann-Döring-Zel'dovich) Theory. Spike theory was also described by Dunkle (Refs 1 & 3). Boyle et al (Ref 5) in the paper entitled "Measurements of the Detonation-Front Structure in Condensed Explosives" lists *spike pressure* for Comb B as equal to 388 kbars

The explanation of the difference between "spike pressure" and *Chapman-Jouguet (C-J) pressure* is given under "Detonation (and Explosion) in Condensed (Liquid and Solid) Explosives"

Refs: 1) Dunkle's Syllabus (1957-1958), pp 175, 189-98 & 298 2) Cook (1958), 68-77 & 79-80 3) Dunkle's Syllabus (1960-1961), pp 14f, 15a & 15e 4) M.W. Evans & C.M. Ablow, ChemRevs **61**, 147 (1961) 5) V.M. Boyle et al, 10th Symp-Combustn (1965), 855-61 6) C.G. Dunkle, private communication, Nov 1968

Detonation, Spike Theory. See under Detonation; Spike Pressure and Spike Theory

DETONATION SPIN (SPINNING OR HELICOIDAL DETONATION).

Accdg to Zel'dovich & Kompaneets (Ref 20), Campbell & Woodhead (Ref 1) investigating deton in mixts of carbon monoxide and oxygen obt'd photographs in which the wave front was represented by a wavy line with which a system of horizontal bands was associated in the region of a cross section of the reaction products (See Fig). Each wave in the picture of the front corresponded to a band in the cross sectional region of the reaction products. A detonation of this

type is now known as *spin detonation*, but it was called *helicoidal detonation* and its theory, *helix theory*. The word "spin" is also used in Russian literature

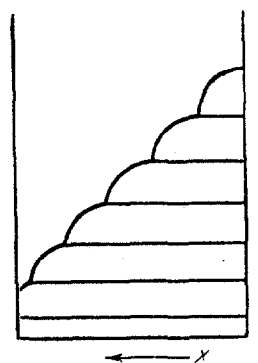

Fig 2

Cook (Ref 16, p 143) in discussing the existence of free electrons in combustion flames and gaseous detonations (first mentioned in 1893 by Turpin and then theoretically discussed in 1909 by J.J. Thomson), quoted the paper of Bone et al (Ref 3), who stated that A.E. Malinovskii et al observed in 1924 the presence of free electrons during detonations of benzene-air mixtures and later (1930 & 1933) of methane-, ethylene-, and acetylene-air mixtures. Bone et al confirmed Malinovskii's results in the case of spinning detonation of a moist $2\text{CO} + \text{O}_2$ mixture (Ref 16, p 143)

Accdg to Zel'dovich & Kompaneets (Ref 20, p 170), spin detonation always arises in a pipe of a given diameter for a known composition of the mixture, regardless of susceptibility to initiation, where the distance between L (equal to the distance between bands) proves to be strictly constant. With a change of the inside diameter of the pipe d , the distance L is changed in proportion to the pipe diameter in such a way that the ratio L/d remains constant

There have been proposed two hypotheses concerning the nature of detonation spin: 1) The effect is elicited by the fact that in a spin detonation the reaction takes place periodically 2) The effect is elicited by the motion of ignition zone;

this motion is small compared with diam of the pipe and is directed along a helical path near the wall surface of the pipe. The validity of the 2nd hypothesis was demonstrated by Campbell et al (Refs 1 & 2) in a series of experiments. These experiments are also described in Ref 20, pp 173-74

Dunkle (Ref 15, pp 125 & 130-31) briefly described detonation spin obt'd by Eyring et al (Ref 4, p 61) for gaseous mixtures in tubes, notably CO+O₂ saturated with water vapor. High-speed photographs showed a helical movement of the light source about the circumference of the tube. If the inside surface of the tube has been coated with French chalk or a thin film of silver, the coating was found to be cleared off. Spin in detonations was explained by Eyring et al on the basis of the generally accepted structure of the detonation wave. The front was considered to consist of a region of high pressure, rising rather discontinuously from that of the quiescent gases, and high temperatures. At these high temps and pressures, the reaction proceeds by a chain mechanism in which the surface participates. Thus the heterogeneous (at the solid surface) reaction is faster than the homogeneous (gas phase). Detonation conditions are first reached therefore at the surface. Chemical reaction then spreads along the surface circumferentially, where the temperature and pressure are high, but is quenched in the forward direction by the abrupt fall in both. The resultant of this rotation in one sense or the other, and the slower movement of the front itself along the tube axis, is the observed helical path. Immediately behind the surface reaction the surface is cleared of reactant molecules, but in the period of one rotation there is time for re-absorption of others. Accordingly the process continues along the helical path as long as fresh reactants diffuse toward the walls. Some support of this theory is given by experiments with electric and magnetic fields. An electric field of ca 1000 volts/cm applied to the moist CO-O₂

mixtures increased slightly the pitch of the spin and the detonation rate, as the front approached the negative electrode. Both properties decreased markedly, on the other hand, as the wave traversed the field in the negative-to-positive direction. Application of an axial magnetic field of 22000 gauss had similar but weaker effects. If the gas mixture had been pre-dried, such electrical influences became weaker; i.e., the "spin was stabilized". It was inferred that positive ions are involved in the combustion reaction chains. The polar surface of the glass surface may reduce the energy required for ion formation. Eyring et al noted in this connection that unsolvated positive ions always react with low activation energies (Ref 15, pp 130-31)

Dunkle also stated that Fay (Ref 12), as quoted from Nicholls (Ref 13), correlated the phenomenon of spin with the natural vibration of the gas particles behind the detonation front. Using the linearized theory of sound as an approximation, Fay developed an equation for spin frequency. For transverse vibrations in a rectangular tube:

$$\nu = \frac{a}{2} \left[\frac{n^2}{w^2} + \frac{m^2}{h^2} \right]^{1/2}$$

where: ν = spin frequency at the wave front; a = speed of sound in the burned gases; n = an integer denoting the number of circumferential crests; m = an integer denoting the number of radial nodes (points of zero radial velocity); w = width of the tube and h = height of the tube

For a small rectangular shock tube having $w = 3/8$ inches and $h = 1/2$ inch, if $n = 0$ & $m = 1$, $\nu = 34800$ cps and if $n = 1$ & $m = 0$, $\nu = 46400$ cps. By use of the relation:

$$P = D/\nu$$

where: P = pitch of the spin and D = detonation velocity, the pitch in these two cases is respectively 1.86 and 1.4 inches. These values compared favorably with 1.7 inches measured from negatives

For a cylindrical tube, Fay gave the pitch-diameter ratio as:

$$\frac{P}{w} = \frac{\gamma_b - 1}{\gamma_b K_n}$$

where γ_b = specific heat ratio for combustion products and K_n = function depending on the mode of oscillation

If γ_0 is assumed to be 1.2 & $n=1$ in the above equation, the pitch-diam ratio becomes 3.13. This value agrees with results of Campbell & Woodhead, who obtd $\gamma_0 = 3$. For the primary mode of oscillation, the ratio P/w appears to equal the perimeter of the tube (Ref 13, p 37 & Ref 15, pp 125-26)

In his supplement to Syllabus, Dunkle remarked (Ref 22, p 11d) that schlieren photography of deton waves in 40/60 C_2H_2/O_2 initially at 1/4 atm showed a wavy pattern of criss-crossing dark diffuse lines behind the front. Fay & Opel (Ref 17) calculated that if these lines are a weak wake of Mach waves in supersonic flow, the flow of the burnt gases with respect to the front is Mach 1.14 rather than Mach 1.00 as in a C-J process. However, at this pressure the reaction is complete within a fraction of a millimeter behind the front, and the flow could very well accelerate to Mach 1.14 with density decrease below the C-J value. Fay & Opel traced the effect to the boundary layer. At or near sonic velocity, as at the C-J plane and beyond, a minute divergence had a marked effect. Similarly, at the throat of supersonic nozzle, an infinitesimal change in cross-sectional area produced a finite acceleration of the flow. Objection was raised, however, by Duff & Knight (Ref 17a) that evidence of a large density gradient at the end of the reaction zone is lacking. Wood & Kirkwood (Ref 17b) suggested that even in normal detonation, the reactions are incomplete at the C-J point in a tube of finite diameter (Ref 22, p 11d)

Lewis & von Elbe noted in discussion on spinning detonations (Ref 23) that, in an ideal one-dimensional detonation, the

reaction zone would consist of a zone of constant depth behind the shock front in which there is little or no reaction, and a much narrower zone in which the reaction rapidly goes to completion. Such a system would be unstable because any slight local pressure fluctuation in the induction zone would shorten the induction period and destroy the one-dimensional symmetry. The spin may represent such pressure fluctuations, possibly of acoustic origin. Reaction is completed within the pressure heads before it would normally be completed after the initial compression in the shock front. The shock front consequently becomes disturbed and nonplanar. Complex phase relations, which might exist between the main shock and the local pressure pulses, could govern the periodic jumps in reaction rate

Spinning detonation would, therefore, be most likely to occur whenever the induction zone is so thick that the transverse vibrations responsible for the phenomenon are not damped out by the mass flow. This would explain why spin is associated with mixtures near the detonation limits, and disappears in highly detonable mixtures in which induction times are very short and induction zones are very thin

Pukhnachev (Ref 26) made a stability analysis of Chapman-Jouguet detonations to clarify the development of spinning detonations. The phenomena leading to them cannot be described by solution of simple hydrodynamic and reaction-kinetic equations for flat detonation fronts. The analysis was based on previous detonation stability analyses by Shchelkin et al with constant supersonic flow postulated along the z-axis at $z < 0$. There is a sharp discontinuity at $z = 0$, followed by the combustion zone. At $z > 0$ the flow is subsonic. The chemical reaction rate is given in terms of a single variable, the concentration of unreacted molecules. Radial, tangential and axial perturbations of the velocity, pressure, density and concentration are introduced in the subsonic region. The small flow perturbations are assumed to be superimposed

harmonics. Their individual histories are analyzed to yield complex equations for the perturbed discontinuity. The equations are solved by an asymptotic method in the form of an "eigenvalue problem" (See Note). The relationships among certain parameters were machine-calculated and plotted (Ref 32)

Note: Eigenvalue (Eigenwert in Ger) is a characteristic value or number for a constant in a differential equation, the solution of which is possible

Dabora et al (Ref 27) in a study of detonating H_2-O_2 mixtures surrounded by a compressible medium such as an inert gas, found that in columns of explosive mixture narrower than a limiting width, the velocity decrement reached 8-10% and led to quenching. Some features of a spinning detonation are observed near the limit. It appears that with a proper choice of confining gas and of column width, "spin" can be induced at will

Striae observed in photographs of detonation, such as those discussed by Brossard et al (Ref 30), have been attributed to spin of the detonation front (Ref 32)

Macpherson (Ref 31) discussed the three-dimensional wave system of spinning detonation

Considerable work on spinning detonation was done in Russia, as can be seen in Refs 5, 6, 7, 10 & 19. Some of this work was briefly discussed in the book of Zel'dovich & Kompaneets (Ref 20), nothing on detonation spin is found in Rus books of Baum, Stanyukovich & Shekhter (1959) and of Andreev & Belyaev (1960). The works of Borisov & Kogarko (Ref 25) and of Pukhnachev (Ref 26) appeared later than the book of Zel'dovich & Kompaneets
Refs: 1) C. Campbell & D.W. Woodhead, *JCS* **1926**, 3010-21 and **1927**, 1572-78; *CA* **21**, 823 & 3271 (1927) (Detonation spin)
 2) C. Campbell & A.C. Finch, *JCS* **1928**, 2094 (Deton spin) 3) W.A. Bone et al, *TrPhilSoc(London)* **228A**, 197 (1929); **230A**, 363 (1932) and **235A**, 29 (1935) [Discussion on detonation spin and on the presence of free electrons in spinning deton waves

observed by A.E. Malinovskii et al, *Zh-KhimFiz* **21**, 469 (1924)] 4) H. Eyring et al, "The Chemical Reaction in a Detonation Wave", OSRD **3796** (1944)
 5) K.I. Shchelkin, *DoklAkadN* **47**, 501 (1945) (On the theory of deton spin)
 6) Ya.B. Zel'dovich, *DoklAkadN* **52**, 147 (1946) (On the theory of deton spin)
 7) N. Manson, "Propagation des Détonations et des Déflagrations dans les Mélanges Gazeux", *EdOfficeNatlEtudesRecherchesAeronautiquesInstFranç, Paris* (1947) 8) S.M. Kogarko & Ya.B. Zel'dovich, *DoklAkadN* **63**, 553 (1948) (Experiments conducted in order to prove the existence of the zone of increased pressure directly behind the shock wave front in spin detonation) (These experiments are also described in Ref 20, pp 183-85)
 9) Ya.B. Zel'dovich & I.Ya. Shlyapintokh, *DoklAkadN* **65**, 871 (1949) (The reaction propagation regime in an expl gaseous mixture, being similar in its mechanism to spin detonation, was studied, making use of a fast moving 5.5 mm bullet in a 30-35 mm pipe) (This experiment is also described in Ref 20, pp 182-83) 10) K.I. Shchelkin, "Bystroye Gorennye i Spinovaya Detonatsiya Gazov" (Fast Combustion and Spinning Detonation of Gases), *Voyenizdat, Moscow* (1949) 11) J. Mooradian & W.E. Gordon, *JChemPhys* **19**, 1166-72 (1951) & *CA* **46**, 1257 (1952) (Spinning detonation) 12) J.A. Fay, *JChemPhys* **20**, 942-50 (1952) & *CA* **47**, 1931-32 (1953) (A mechanical theory of spinning detonation) 13) J.A. Nicholls et al, "Final Report Detonative Combustion", *EngrgResInst, Univ of Michigan, Ann Arbor, Mich, Project M898* (1953). Contract No AF 33(038)-12657, Wright Air Development Center, US Air Force; pp 36-38 (Discussion on spinning detonation based on mechanical theory of Fay) 14) J.P. Toennies & H.G. Wagner, *ZeitElektrochem* **59**, 7-15 (1955) & *CA* **49**, 8602 (1955), Spinning $CO-O_2$ detonations were photographed in different ways with a rotating camera. Photographs in which the film proceeds vertically to the process are compared with those in which the film proceeds in the direction of motion

of the image. An insight into the spatial course of the change is obtained by a photographing arrangement which permits the simultaneous observation of the change at different spots & from different sides. Theories of Manson (CA 43, 8140) and Fay (See Ref 12) are discussed in connection with the results. The rotating camera of high resolution is described 15) Dunkle's Syllabus (1957-1958), 125-26 & 130-31 (Detonation spin as observed by Eyring et al and described in Ref 4) 16) Cook (1958), 143 (Discussion on the work of Bone et al and of Malinovskii et al) (See Ref 3) 17) J.A. Fay & G. Opel, JChemPhys 29(4), 955-56 (1958) (Two-dimensional effect in gaseous detonation waves) 17a) R.E. Duff & H.T. Knight, Ibid, 956-57 (Further comments on the letter of Fay & Opel) 17b) W.W. Wood & J.G. Kirkwood, Ibid, 957-58 (Present status of detonation theory) 18) W.E. Gordon et al, "Limit and Spin Effects in Hydrogen-Oxygen Detonations", 7thSympCombstn (1959), pp 752-59 19) A.S. Predvoditelev, "Concerning Spin Detonations", 7thSympCombstn (1959), pp 760-65 & CA 56, 619 (1962) 20) Zel'dovich & Kompaneets (1960), 170-85 (Spin and spinning detonation) 21) D.H. Edwards & T.G. Jones, BritJApplPhys 11, 190-94 (May 1960) (Vibration phenomena in detonation waves in hydrogen-oxygen mixtures). 22) Dunkle's Syllabus (1960-1961) p 11d (Discussion on work of Fay & Opel listed here as Ref 17) 23) B. Lewis & G. von Elbe, "Combustion, Flames and Explosions in Gases", Academic Press, NY (1961), 541-46 (Spinning detonation) 24) J.E. Dove & H.G. Wagner, "Photographic Investigation of the Mechanism of Spinning Detonation", 8thSympCombstn (1962) & CA 57, 16090 (1962) 25) A.A. Borisov & S.M. Kogarko, DoklAkadN 149, 623-25 (1963) & CA 59, 376 (1963) (The zone existing between the shock-wave fronts and the reaction zone was studied. The configuration of this zone and the state of gas in it were investigated exptly. The gaseous $\text{CH}_4 + \text{O}$ mixt was detonated at 30 mm in a tube 65 mm x 4 m. The exist-

ence of a zone of unburned gas was established behind the shock-wave front. It was found also that the front of the reaction zone coincides with the front of self-ignition of gas warmed by the shock wave) 26) V.V. Pukhnachev, ZhPrikl-Mekhan i TekhnFiz No 6, 66-73 (1963) (Stability of Chapman-Jouguet detonation) 27) E.K. Dabora et al, "The Influence of a Compressible Boundary on the Propagation of Gaseous Detonations", 10thSympCombstn (1965), pp 817-30 28) 4thONR-SympDeton (1965) (No papers on spinning detonation) 29) D.H. Edwards et al, JFluidMech 26(2), 321-36 (1966) (The structure of the wave front in spinning detonation) 30) J. Brossard et al, "Propagation and Vibratory Phenomena of Cylindrical and Expanding Detonation Waves in Gases", 11thSympCombstn (1967), pp 623-33 31) A.K. Macpherson, "The Three-Dimensional Wave System of Spinning Detonation", 12thSympCombstn (1969), pp 839-50 32) C.G. Dunkle, private communication, Jan 1969

Detonation (and Explosion), Spontaneous.

Under the heading "Combustion, Spontaneous or Self-Ignition", on pp 429-30 in Vol 3 of Encycl, a brief discussion is given of self-ignition of some combustible materials and of spontaneous deflagration of propellants

Following are some remarks of Mr. C.G. Dunkle (Ref a) on "spontaneous detonation and explosion":

A critical size for "spontaneous detonation thru self-heating" may be a general phenomenon, even though widely varying for different explosives. The view of this as a possibility arises from the indication, in the Arrhenius equation, that there is some decomposition constantly taking place even at room temperatures. As the linear dimension d of the charge increases, the rate of heat evolution increases as d^3 , whereas the rate of heat dissipation by conduction increases only as d^2 . Theoretically, therefore, a size must be attainable at which the sample will eventually

detonate spontaneously. For instance, this has been calculated for Mercury Fulminate as a cube 4 feet on edge

Actually the "spontaneous detonation", as understood now, is one taking place when initiated by an agent which is not perceived, such as shock waves from another explosion at some distance [See Detonation (and Explosion) by Influence or Sympathetic Detonation]. In such cases, the term "spontaneous" may include an inference that the initiation is "instantaneous", i.e., without an "induction period". Initiation by "thermal means" can hardly be spontaneous in this sense. In such cases there is always an induction period however abruptly heat is applied, for it can only start a burning reaction, which develops into detonation after an induction period [See Detonation (and Explosion), Induction Period]

It becomes a problem in semantics to set a time limit for "development" within which a process can be considered "spontaneous" or "instantaneous". These two words seem to apply well to such extremely sensitive compounds as Nitrogen Triiodide and Cupric Azide, which explode at the slightest touch when dry and, in addition, explode at a fairly low temperature. Attempts to correlate initiation in such cases with the attainment of a certain temperature seem unrealistic, especially in view of differences between relative sensitivity of different compounds to mechanical and thermal influences. For example, Mercuric Azide is so sensitive to impact that it explodes even under water, but its heat sensitiveness is about the same as that for Cadmium Azide, which has been reported not to explode by percussion (Ref 5)

Information about susceptibility of different explosives to spontaneous detonation is highly important from the viewpoint of safety. In Refs which follow are listed examples of spontaneous detonations of substances, some of them previously considered safe in this respect

Spontaneous initiation observed during cryst growth of LA & MF, listed in Ref 4, p 154 and described in Ref 6, p 13e, is

discussed under Detonation, Spot or Hot Spot Initiation of

- Refs: 1) A.A. Shidlovskii, *ZhPriklKhimii* **19**(4), 371-78(1946) (Explosive mixtures of water and methanol with Mg and Al) (Engl transl available at PicArns library)
 2) Linden Laboratories, Inc. State College, Pa, "Studies of the Reactivity of Solids", Contract DAI-28-017-ORD-(P)-1405, Project TA3-5001, Final Report, 10 June 1955
 3) H. Ellern & D.E. Olander, "Spontaneous Explosion of a Normally Stable Complex Salt", *JChemEduc* **32**, 24(1955) [The salt which spontaneously exploded was pure Trihydrazinenickel(II) nitrate prep'd by adding an ethanolic soln of nickelous nitrate, slowly and with agitation, to a 40% ethanolic soln of hydrazine hydrate. The pptd fine pink pdr was separated, washed with ethanol and then dried for 16 hrs in a vacuum desiccator over Ca chloride and powdered ethyl cellulose. When the dish contg ca 1.5 g of material in the form of a cake was carried in the operator's hand, a spontaneous explosion took place with a deafening report, shattering the dish and badly bruising the operator's index finger]
 4) Dunkle's Syllabus (1957-1958), pp 137-38 (Frank-Kamenetsky formulation for instantaneous heating), 138 (Arrhenius equation); 138 (Critical size for spontaneous detonation); 140 (Spontaneous ignitions); 146 (Spontaneous expln caused by traces of AgN_3 which took place at Linden Lab is discussed); 154 (Spontaneous initiation during growth of a cryst in soln observed by Dr J.V.R. Kaufman for $\alpha\text{-PbN}_6$ and by Dr G.D. Rogers for $\beta\text{-PbN}_6$ & HgN_6)
 5) F.P. Bowden, "Spontaneous Explosions", *PrRoySoc* **246A**, 146-58 (1958) (Spontaneous explns of azides are on pp 150-52)
 6) Dunkle's Syllabus (1960-1961), p 12a (Addnl information on Frank-Kamenetsky formulation); 13e (Description of spontaneous initiation listed in Ref 4, p 154) 7) T.B. Joyner et al, "Explosive Sensitivity of Cobalt Ammine Azides", *Nature* **196**, No 4893 (1962) 8) M.M. Braidech, "National Fire Protection Association, Committee on Chemicals and Explosives", *C & EN*, May

21, 1962, p 86 9) Anon, "Unknown Reaction is Cause of Blast" (Chlorinated Rubber with ZnO), C & EN, Sept 10, 1962

10) Anon, "Trichloroethylene Vapor Ignition", C & EN, Feb 18, 1963, p 68

11) Anon, "Hydrolysis of Xe Fluorides Gives XeO₃" (A white solid, easily exploding), C & EN April 1, 1963, pp 45-6

12) Anon, "The Second Fatal Explosion in Less Than Two Years Ripped Through Hercules-Operated Allegheny Ballistics Laboratory" (Powdered Al and Al Perchlorate in a NC-NG mix), C & EN, May 6, 1963, p 19

13) Anon, "Perchlorate Mixture Explodes at UCLA Chemistry Laboratory" (Seemingly innocuous perchlorate systems should be treated as extremely hazardous), C & EN, July 8, 1963, p 47

14) Anon, "Water Controls Detonability of Some Explosive Mixtures", C & EN, Sept 16, 1963

15) Anon, "Cause of Utah Potash Mine Explosion Revealed" (Failure to carry away combustible gas-air mixtures by ventilation before they accumulate in explosive quantities), C & EN, Oct 14, 1963

16) Anon, "Solvent-Oxidizer Mixtures are Explosives" (Violent and unexplained reaction between nitrogen tetroxide and many halogenated hydrocarbons), C & EN, Nov 23, 1964, p 53

17) S.W. Benson, "Hazardous Mixtures" (A comment questioning both "violent" and "unexplained"), C & EN, Dec 21, 1964

18) Anon, A report stating that scientists at the George C. Marshall Space Flight Center, Huntsville, Ala found that several halogenated solvents react explosively with liquid oxygen when ignited with high-energy source, C & EN, June 14, 1965

19) Anon, "Liquid OF₂-Silica Mixture Explodes", C & EN, Feb 15, 1965, p 41

20) Anon, "Fluorination Mixture Explodes After 10 Hours", C & EN, March 1, 1965, p 36

21) E. Levens, ACS Committee on Chemical Safety, "Perchlorates - Yet Another Explosion Involving Magnesium Perchlorate", The Capital Chemist, March 1966, p 71

22) Anon, "Fertilizer-Grade Ammonium Nitrate" (Gave no detonation when burned alone but detonated when mixed with com-

bustible materials and confined in containers that permitted rapid build-up of pressure from gases generated in burning), C & EN, May 9, 1966, p 55

23) A.M.G. MacDonald, "Oxygen-Flash Technique", C & EN 44, No 19, pp 7-8, May 9, 1966)

(Many analytical and other chemical procedures can be hazardous if handled carelessly, and explosive samples can cause potentially dangerous accidents in many methods of elemental chemical analysis)

Detonation, Spot or Hot Spot Initiation of.

Under the term *spots* may be understood small, hard particles of material, such as sand, powdered glass, carborundum, etc, incorporated in an explosive either on purpose or present as impurities. Such particles are known as *grit*. The term *spots* may also be applied to small bubbles of air or other gases entrapped in cast explosives or incorporated on purpose in other expls, such as by rolling cartridges of gelatinous Dynamites. The reason why these spots are called *hot spots* is explained below

According to investigations of Bowden et al (Refs 6, 7, 8, 11, 17, 19 & 20), there is a good deal of evidence that the initiation of expls by impact and by friction is, commonly, thermal in origin. The mechanical energy of the blow (strike) or of rubbing is degraded into heat and concentrated to form, under certain conditions, the small *hot spots*. The size of these spots varies from 10⁻⁵ to 10⁻³ cm in diam and their duration is ca 10⁻⁵ sec. With many expls the necessary hot spot temp may be 400 to 500°C (Ref 22, p 159)

The spots may be formed in two main ways: 1) By friction on the confining surfaces of expls, on grit particles, or on crystals of the explosive itself and 2) By the adiabatic compression of small occluded gas bubbles; the presence even of a small bubble can render most expls very sensitive to impact (Ref 19)

The growth of a small expln from a hot spot to one of finite dimensions would take place if the rate of evolution of heat by

chemical reaction within the small volume were greater than the rate at which it is lost to the surroundings by conduction and other means; if not it will die away. This means that, if a particle of an explosive is smaller than a certain minimum size (which may be called "critical"), the dissipation of heat will be greater than its evolution and no expln would take place. This is true not only for initiation by impact and friction, but also by heating. In initiation by heat at "hot spot temperature" deton takes place only if the crystals are not below critical size. If they are below that size or when they are larger but are attempted to be initiated at lower than "hot spot" temp, no expln but only thermal decomposition might take place. This may be accompanied by splitting and breaking up along crystallographic planes. This may occur with violence and it is suggested that the spreading of the dislocation and breaks thru the crystal may play a part in the propagation process. It will also influence the rate of thermal decomposition by exposing a large amount of fresh crystal surface

If a heap of crystals of uniform size is used, the impact sensitivity is independent of the size of the individual crystals in the heap and remains approx of the same sensitivity. It seems that there may be two factors involved in detonation of crystals. First, the probability of explosion is determined by the number of potential initiation centers or hot spots and this is naturally greater for large individual crystals than for smaller ones. The second is the fact that the reaction cannot grow to an expln unless the crystal exceeds a critical size. It should be noted that, under impact, the single crystals are crushed and flow plastically to form a pellet, the thickness of which is one-tenth to one-fourth of the original crystal (Refs 6, 7, 8, 11, 17, 19, 20 & 34)

Earlier work by Bowden et al (Refs 3 & 4) has shown that for many expls the action which follows the impact begins by comparatively slow burning which then accelerates to a few hundred meters per se-

cond before passing over into expln or deton, provided requirements of critical conditions are fulfilled. The chemical reactions occurring during this burning stage are different from, and less complete than, decomposition in detonation. With metallic azides this intermediate burning stage was not observed

The sites of formation of hot spots may be provided in both liquid and solid expls not only by bubbles of gas but also by bubbles of vapor, if the expl is more or less volatile. The importance of some heterogeneous initiation mechanism is shown by the failure of deton to propagate, in at least some expls, when the density of material exceeds a certain value [See under "Detonation (and Explosion), Resistance to"]. For the type of expls referred to by D. Price as Group 2 (Ref 33), see under "Detonation (and Explosion), Critical or Limiting Charge Densities. Price noted that in other expls, however, the homogeneous process plays the major part in the transmission, if not the initiation, of detonation (Ref 34)

The hot spot mechanism is particularly important in systems near the detonability limits, and in maintaining detonation at relatively low velocity and low energy-release rate. The hot spots appear to supplement the Hugoniot energy by concentrating the temperature effect of the compression within small portions of the just-compressed layer as to initiate self-heating at these points, and decrease the need for thermal energy from other sources (Ref 34)

The following discussion on influence of hot spots in initiation of explosion by impact friction and heat is given in Dunkle's Syllabi (Refs 22 & 26):

Ref 22, pp 153 & 162. In the case of granular materials the *hot spots* in which the reaction is initiated originate along the friction surfaces of neighboring grains, whereas in cast materials similar action occurs between separate crystals and the crystal fragments into which the substance is broken by the impact. Low density, due to voids, also makes the material less homogeneous and consequently distribution of

heat less uniform. Hence, the hottest regions may have temps way above the average. Even though the lower temps in other regions might increase the time required for complete reaction and thus lengthen the reaction zone, the net effect appears to be an increase in sensitivity. An even more important effect of voids is that due to adiabatic compression of the contained air or other gas. This greatly enhances the effect of impact pressure, and Bowden has estimated that temps of over 1000°C can be reached by such means. Intercrystalline friction is probably important only with primary expls which cannot be melted, since melting would limit the hot spot temps. Experiments similar to those described in the book of Bowden & Yoffe (Ref 19) for liquid expls verified the contention that the compression of trapped gas bubbles produces the necessary hot spots for initiation of solid expls. Andreev (as quoted by Bowden in Ref 21a, p 74) attributed the initiation of detonation, in solid expls, mainly to sudden rise of pressure when a suspension of the solid explosive which is formed in the gaseous combustion products, explodes. The minimum temperature developed by hot spots for initiation can be determined by compression of a known volume of air surrounding the expl. This type of test, described in Ref 19, p 60, gives results, shown in Table IX of Ref 22, p 162, which are in fairly close agreement with the friction test

Table

| Explosive | Initiation by Friction, °C | Initiation by Adiabatic Compression of Air, °C |
|-----------|----------------------------|--|
| PETN | 400-430 | 460-500 |
| LSt | 430-500 | 570-600 |
| LA | 430-500 | 570-600 |
| MF | ca 550 | 630-690 |
| Tetracene | ca 430 | 400-450 |

Ref 22, p 154 & Ref 26, p 13e. Spontaneous initiation during growth of a crystal in soln was observed by Dr J.V.R. Kaufman for α -PbN₆ and by Dr G.D. Rogers for β -PbN₆

& HgN₆. It was noted that such phenomenon is probably due to release of energy in small regions or release of strain by fracture along a cleavage plane. The spontaneous initiation took place during the early stages of crystal growth, soon after addition of seed crystals to supersaturated solns, when the crystals have grown only a few mm. When the crystals, grown sometimes to sizes of 1 cm long, were removed before deton took place, they remained undetonated. Rogers pointed out that possibly small crystals of α -LA grew on the surface of the β -LA, and that spontaneous explns could occur when the two phases were in contact due to interface energetics. Energy stored in an interface would be released in a small volume and might therefore produce a *hot spot*. Both the creation of high-energy interfaces and the triggering mechanism for release of the energy are unpredictable and difficult to control

Ref 22, pp 159-60. In the lecture entitled "Thermal Theory of Initiation", delivered by M.T.W. Stevens at PicArns on 8 Jan, 1958, it was stated that a question that arises in considering the mechanism of initiation is how the mechanical energy of a blow or rubbing is able to produce the chemical excitation which leads to the explosive reaction. One mechanism proposed, the so-called *tribochemical*, is that the combined application of high pressures and rapid shearing either causes a direct rupture of the molecule or produces sufficient deformation of the molecule to bring about rapid chemical reaction. The experiments of Bowden et al provide strong evidence, however for the theory that the ignition is thermal in origin. The mechanical energy is degraded into heat which is concentrated in a small region to form a hot spot of the order of 10⁻⁵ to 10⁻³ cm in diameter. It may also be noted that the initiating effects of high speed particles in detonation may be traced to thermal influences

Effects of friction also, although this is a complex phenomenon, can likewise be correlated by the thermal mechanism. When solid surfaces are rubbed together, contact will occur only at the summits of the highest

irregularities so that the area of contact is actually very small. The heat is concentrated at these spots so that the temperature rise may be quite high. When two dissimilar metals are used, the temp may be measured by using the sliding contact as a thermocouple. The temp of the hot spots should be limited to the mp of the slider. Table VII in Ref 22, p 160 indicates that sliders of mp not lower than 480°C (such as alloys 73/27-Ag/Sn or 70/30-Ag/Sb) are required to form a hot spot sufficient to initiate NG

Ref 22, pp 160-61. Table VIII indicates effects of grit hardness and melting point on formation of hot spots of sufficient "explosion efficiency" for initiation of PETN by friction or impact. Under *explosion efficiency* is understood the percentage of the number of ignitions per the number of trials. Any grit of mp below 400°C, although its hardness might be as high as 2-3 (by Moh's scale), is inefficient. Efficiency of 50% in friction and 6% in impact was achieved with grit of AgBr which melts at 434° and has hardness of 2-3. Better results (60% in friction and 27% in impact) were obtained with PbCl₂ (mp 501° and hardness 2-3). One hundred percent efficiency in friction and impact was obtained with powdered glass (mp 800° and hardness 7). Tests with RDX gave essentially the same results, while for primary expls LA and LSt a higher temp (ca 500°) was required for "explosion efficiency"

Ref 22, pp 161-62. Under the title "Thermal Effect of Impact" is discussed initiation of liquid expls, such as NG, NGc, etc. It differs from initiation of solid expls (discussed on p 153 of Ref 22) in that there is no friction between crystals as in solids, but everything depends on rise of temperature created by adiabatic compression of gas or vapor in minute bubbles.. For example, with NG contg a bubble as small as 0.1 mm in diam 100% explns can be obtained with impact energy of 400 gram-cm, while 10⁵ to 10⁶ g-cm are required when no gas bubble is present. The temp T₂ reached in a bubble due to adiabatic compression of the gas depends, in the case of ideal gas, on the

initial temp and on the pressure ratio as shown by equation:

$$T_2 = T_1 \left(\frac{P_2}{P_1} \right)^{\frac{\gamma-1}{\gamma}}$$

where γ is a value varying with gases. It is given as 1.4 on p 34 of Ref 22

This eq indicates that if the initial pressure P₁ of the gas is raised, the temp T₂ is reduced. In case of NG, while with P₁ of 1 atm and impact energy of 5000 g-cm produced 100% expln efficiency, no explns took place when P₁ was raised to 20-30 atm. Explns can be produced with very low P₁ (such as below 10⁻⁵ mm). In case of NG, the bubbles are filled with NG vapor, since its pressure (10⁻³ mm at RT) is sufficiently high to produce bubbles, but the bubbles might contain air to produce better effects. The minimum temp required for initiation can be determined by compression of a known volume of air surrounding the expl. This type of test described in the book of Bowden & Yoffe (Ref 19, p 60) gives 450-480°C for initiation of NG by adiabatic compression of air. These results are in fairly close agreement with the friction tests Ref 22, p 200. Energy transmitted thermally by conduction or radiation (ignoring lateral losses) would supplement the *Hugoniot energy* [See under DETONATION (AND EXPLOSION), THEORIES OF], which both M.A. Cook and M. Sultanoff considered inadequate for propagation of the detonation front. As Cook pointed out, the compression alone within the deton front could raise the temp in a solid usually to only ca 20 to 40% of temp of deton. On the other hand, "hot spots" formed in the compression may make the Hugoniot energy sufficient for initiation by concentrating the temperature effect within small portions of the just-compressed layer so as to initiate self-heating reaction at these points. Such enhancement of the influence of the Hugoniot energy could decrease the need for thermal energy from sources outside the compressed layer. Hence, the importance of hot spots in maintaining detonation at relatively low energy release, or low rate of detonation

Ref 22, p 280. Taylor (Ref 16, pp 30-1) suggested that the method of decomposition in high- and low-velocity regimes is quite different. The low velocity is explainable by deflagration on the surfaces of the grains or films of the expl, initiated by hot spots produced by the heating of the interstitial gases. The action of such hot spots in supplementing the Hugoniot energy [See under DETONATION (AND EXPLOSION), THEORIES OF] and in stabilizing deton at a relatively low energy release, or propagation rate is discussed on p 200 of Ref 22. The high-velocity regime, by contrast, appears to be produced by a bulk thermal decompn thruout the expl material; this is initiated by the motion of the detonation products at the particle velocity, transmitting an unidirectional component of impact pressure or shock process

The following material is extracted from the book of Cook (Ref 23):

Ref 23, p 39. Impact in drop test creates "hot spots" in the expl, the temp of which may be high enough for the decompn to take place at such a rate that the reaction must remain essentially adiabatic once the hot spot is created. It therefore continues to accelerate until deton or expln occurs. Investigators have modified the drop test in many ways to demonstrate the formation of hot spots, the growth of expln from them, the time lag between the creation of hot spot and the actual expln. It has been shown that the time lag in secondary expls obeys the same equation:

$$\log \tau = A/T + B$$

as was found by Garner et al (Ref 3a) in adiabatic decomposition of primary expls

Collins & Cook (Ref 21), employing methods somewhat similar to those described by Rideal & Robertson (Ref 9), confirmed the hot-spot theory of initiation of expls by impact and obtd initiation time-lag data essentially in agreement with data of British and Australian investigators. Their method is briefly described by Cook (Ref 23, pp 39-40)

Ref 23, pp 179-80. The impact sensitiveness by grit particles was studied by Copp et al (Ref 13), using the British method which gives values known as FI (figure insensitiveness), briefly described in Vol 1 of Encycl, p XII. They used as a standard grit particles of Si carbide passing thru 100 mesh - and retained on 200 mesh screen in various amounts. Results of their tests are listed in Table 8.2, p 179 of Cook together with some results obtd by Bowden & Gurton (Refs 7 & 11). B & G expressed sensitization by grit either by the quantity designated as PSG [=100 (1 - Am/Ae)], where Am is mixture and Ae is pure expl, based on gas evolution, each cap giving a quantity of gas greater than exptl error being called an ignition whether deton occurred or not. They also expressed the sensitiveness by the quantity FIG [=100 (1 - Am/Ae)], where the A's were detd from curves based on complete detonation or failure, a partial expln being called a failure. It was shown by the same investigators that the impact sensitiveness is a melting point effect. Cook explained their findings in the hot-spot concept as follows:

Impact produces hot spots, the temperatures of which are (frequently) determined by melting of the solid, being effectively buffered at the melting point. Hence, the mp frequently determines the hot-spot temperature, T_0 in the adiabatic-decomposition equation 8.8, listed on p 174 of Cook. If T_0 is below a certain critical value, the reaction will not be adiabatic and, owing to heat loss, may not undergo reaction build-up. But above this critical value it becomes effectively adiabatic and expln then always results after a time T. The failure of grit to sensitize an expl may, however, depend simply on the ratio of the mp of the expl to that of the grit particle. If this ratio is greater than 1.0, no sensitization by the grit particle results, but if it is less than 1.0, the grit particle effectively sensitizes the explosive because it allows the formation of hot spots of higher temperature than those created in the pure explosive (Ref 23, p 180)

Bowden & Gurton (Refs 7 & 11) found that RDX, PETN and Tetrazene were sensitized only by grit particles of mp above 400°, but LA required grit particles of mp greater than ca 500° to increase its sensitivity to impact. The corresponding temp for LSt and MF was ca 550°. These results may thus indicate mp's of ca 500° for LA and 550° for LSt and MF. That the hot-spot temp may be effectively the mp in some primary expls is seen also by the fact that, except from quite large impact energies which may create hot spots of temps somewhat higher than the mp, the time lag τ for impact initiation is surprisingly independent of the potential energy mgh of the fall hammer of impact apparatus. This is shown by the data in Table 8.3, p 181 of Ref 23, taken from the report of Collins & Cook (Ref 21)

Under the Russian term "goriachiye tochki", the book of Baum, Stanyukovich & Shekhter (Ref 24) discussed the results of work on hot spots of Bowden & Yoffe on pp 27 & 49. It was stated on p 27 that Rideal & Robertson determined the hot spot temp for Tetryl as being ca 570°C. The works in Russia by Yu.B. Khariton & A.F. Belyaev on hot spots were discussed on p 48 of Ref 21

Andreev & Belyaev (Ref 25, pp 276-86), in the discussion of thermal theory of initiation of explns by means of "hot spots", described briefly, besides Bowden's work, the investigations done in Russia by N.A. Kholevo & K.K. Snitko

Refs: 1) N. Semenov, "Chemical Kinetics and Chain Reactions", Clarendon Press, Oxford (1935) 2) F.P. Bowden & K.E.W. Ridley, PrRoySoc **154A**, 641 (1936) 3) W.E. Garner et al, TRFaradaySoc **34**, 985 (1938); PrRoySoc **172A**, 299 (1939) & Chim & Ind (Paris) **45**, Supplement No 3, 111 (1941) 3a) D. Frank-Kamenetskii, ActaPhysicochim(Russia) **16**, 357 (1942) & **20**, 729 (1945) 4) F.P. Bowden & D. Tabor, Nature **150**, 1970 (1942) 5) A.F. Belyaev, DoklAkadN **50**, 303 (1945) & JPhysChem **20**, 613 (1946) 6) F.P. Bowden, PrRoySoc **188A**, 219, 311, 329 (1947) 7) F.P. Bowden & O.A. Gurton, Nature **161**,

348 (1948) 8) A.J.B. Robertson & A.D. Yoffe, Nature **161**, 806 (1948) 9) E.K. Rideal & A.J.B. Robertson, PrRoySoc **195A**, 135 (1949) 10) G.B. Kistiakowsky, "Initiation of Detonation of Explosives", 3rdSympCombstn (1949), 560-65 11) F.P. Bowden & O.A. Gurton, PrRoySoc & O.A. Gurton, PrRoySoc **198A**, 350 (1949) 12) A. Yoffe, PrRoySoc **198A**, 373 (1949) 13) J.L. Copp et al, PhilTransRoySocLondon **241A**, 197 (1949) 14) O.K. Rice et al, JPhys & ColloidChem **54**, 885 (1950) 15) F.P. Bowden, PrRoySoc **204A**, 20 (1950) 16) J. Taylor, PrRoySoc **204A**, 30 (1950) 17) F.P. Bowden & H.T. William, Research (London), **4**, 339 (1951) 18) A. Yoffe, PrRoySoc **208A**, 188 (1951) 18a) Taylor (1952), pp 172-73 19) F.P. Bowden & A. Yoffe, "The Initiation and Growth of Explosion in Liquids and Solids", CambridgeUnivPress, England (1952) 20) F.P. Bowden et al, Nature **172**, 378-80 (1953) 21) T.K. Collins & M.A. Cook, "The Measurements of Sensitivity Time Lag and Burning Velocity of Explosives by Drop Test", TechRept No **48**, Contract N7-onr-45107, Proj No 357239, ERG, Univ of Utah, Dec 15, 1955 21a) F.P. Bowden et al, Nature **180**, 73-75 (1957) (Discussion on Initiation and Growth of Explosion in Solids) 22) Dunkle's Syllabus (1957-1958), 153-54, 159-60, 161-62, 200 & 280 23) Cook (1958), 39, 41 & 178-83 24) Baum, Stanyukovich & Shekhter (1959), pp 27 & 48-49 25) Andreev & Belyaev (1960), pp 276-86 26) Dunkle's Syllabus (1960-1961), pp 13c, 17e & 23c 27) C.L. Mader, "The Hydrodynamic Hot Spot and Shock Initiation of Homogeneous Explosives", LASL Rept **LA-2703** (1962) 28) T. Bodington, "The Growth and Decay of Hot Spots and the Relation Between Structure and Stability", 9thSympCombstn (1962) (Pub 1963), pp 287-93 & CA **59**, 12586 (1963) 29) M.H. Friedman, "A Correlation of Impact Sensitivities by Means of Hot Spot Model", Ibid, pp 294-302 30) F.P. Bowden, "The Initiation and Growth of Explosion in Condensed Phase", Ibid, pp 499-516 31) C.L. Mader, "Shock and Hot Spot In-

initiation of Homogeneous Explosives", *PhysFluids* **6**, 375-81 (1963) & *CA* **58**, 8844 (1963) 32) G.P. Cachia, "Summary Paper on Initiation, Ignition and Growth of Reaction", 4thONRSympDeton (1965) (Pub 1967), p 512-16 33) Donna Price, "Contrasting Patterns in the Behavior of High Explosives", 11thSympCombustn (Pub 1967), pp 693-702 34) C.G. Dunkle, private communication, Nov 1968

Detonation (and Explosion), Spread of. See under "Detonation (and Explosion), Induction Period in"; "Detonation (and Explosion), Initiation (Birth), and Propagation (Growth and Spread) in Explosive Substances"; "Detonation (and Explosion), Initiation and Shock Processes" and "Detonation (and Explosion), Propagation of"

Detonation (Explosion, Deflagration and Combustion), Stability and Instability of. Belyaev & Belyaeva in the paper (Ref 2), entitled "Influence of the Envelope of the Charge on the stability of the Detonation", stated that the stability (crit point) of detonation of an explosive is approx the same whatever may be the nature of the inert material composing the envelope (casing) of the charge, provided that the masses (weights) of the envelopes are the same; a casing of Fe having the same diam and the same wall thickness as a casing of Pb has the weaker effect on the point of detonation and velocity of the explosion. The foregoing applies only to casings that are easily shattered, and not to massive walls of very strong materials, as steel

Eyring et al in the paper (Ref 3), entitled "The Stability of Detonation", gave a critical résumé of the classical theory of detonation wave, followed by a presentation of the theories developed for deton in finite charges, time-dependent deton, and failure of deton. These theories lead to the conclusions that the chem reaction in a deton starts at load-bearing contact points, proceeds only at the surfaces of grains, and is possibly diffusion-controlled

The problem of the combustion in-

stability of propellants and explosives was first examined by Zel'dovich (Ref 1), who established that steady-state combustion is possible only for $k < 1$, where $k = \beta(T_s - T_o)$, $\beta = (\partial \ln U / \partial T_o)_p$ is the temperature coefficient of the burning rate U ; T_o is the initial temperature, and T_s is the temperature at the gasification surface. That is, steady-state combustion is possible if the temperature gradient at the surface of the condensed phase (k-phase) is not too large; a solid which is not hot enough cannot burn

Zel'dovich noted (Ref 6) that in order for a stationary burning rate of propellant to be recovered after a pressure fluctuation, enough time must elapse to allow a layer of the propellant to heat up. When the pressure varies rapidly, and there is insufficient time for the solid to heat up, the derivative $\partial u / \partial p$ (rate of burning velocity increase for a given pressure rise) and the pressure exponent become larger than during steady burning. Therefore, in a small chamber at low pressure, when the characteristic hydrodynamic time of pressure variation is shorter than the burn-up time of the heated layer, stability can be lost

A stability analysis for Chapman-Jouguet detonations made by Pukhnachev (Ref 6a) to clarify the development of phenomena leading to spinning detonations is discussed under Detonation, Spin (Spinning or Helicoidal Detonation)

Andreev and Gorbunov (Ref 7) found that high-temperature gases generated during combustion of primary and fast-burning explosives, even at low temperatures, can penetrate into pores and accelerate the combustion. While the combustion of secondary explosives is stable at low pressures, the combustion temperatures of some of them at high pressures may be higher than those of fast-burning explosives. Such secondary explosives may be more susceptible than primary expls to combustion instability. Thus, the combustion temperatures for K Picrate and Tetryl at atmospheric pressure are 2800 and 2400°K, respectively, whereas the maximum comb

temperatures, corresponding to full conversion, are 2800 and 3500°K, respectively. At low pressures in a constant-pressure bomb, combustion of the Picrate was normal at 1 atm and accelerated at 2 atm. Tetryl burned normally at 12, 21 and 41 atm; transition to accelerated combustion occurred at pressures above 50 atm. At higher pressure, Tetryl was substantially less stable than the Picrate. Combustion instability could be induced also by other than chemokinetical factors, such as the transition from conductive to convective heat transfer

Novikov and Ryazantsev (Ref 8) noted that Zel'dovich's stability criterion (Ref 1) is not always satisfied. Attributing the discrepancy to neglect of exothermic reaction in the k-phase, they analyzed combustion stability by the method of small perturbations, taking into account the heat release in the k-phase, and assuming that the combustion zone in the gas and the region of chemical reaction in the k-phase adjacent to the gasification surface are without inertia. The stability condition was determined for two possible combustion regimes with reaction in the k-phase, and for two different types of reaction. In one regime a specific rate of heat release was assumed, and in the other the gasification temperature was considered constant. The conclusions differ from those obtained by the method of Zel'dovich and Frank-Kamenetskii to derive a formula for the rate of gasification of the k-phase, along with the assumption that under nonstationary conditions perturbation of the rate of gasification does not depend on perturbation of the heat flux from the gas phase

The study, by Dabora et al (Ref 11), of detonating H₂-O₂ mixtures surrounded by a compressible medium such as an inert gas is mentioned under Detonation, Spin (Spinning or Helicoidal Detonation). In such confinement the detonation proceeds more slowly than if confined by a rigid wall. The velocity decrement depends primarily on the ratio of initial densities of explosive and inert gases, the length of the detona-

tion reaction zone, and the width of the column of explosive gas. In mixtures beyond the limit there is no shock, only a combustion wave

On the basis of a previously found analogy between instability in a rocket motor and in a detonation wave, Aslanov (Ref 12) made an analysis of combustion instability with respect to small perturbations. It was assumed that the combustible mixture is incompressible and that combustion takes place in the induction regime which usually obtains in rocket motors. The thruster was considered to consist of two sections: 1) where the mixture is formed and 2) where combustion takes place and the pressure is generated. The principal mechanism involved in the combustion process was assumed to be successive ignition, but other mechanisms such as turbulent frontal combustion were also considered. The analysis yielded two instability criteria, expressed in terms of the Mach number in zone 1, the velocity ratio in zones 1 and 2, the isentropic exponent in zone 2, the activation energy, the temperature of the cold gas, the pressure upstream of the combustion zone, and the pressure drop due to the combustion

Novozhilov (Ref 9) noted other instances where the instability criterion of Zel'dovich is not satisfied. He also noted Zel'dovich's assertion that the form of the stability criterion may change if the variation in the surface temperature and the inertia of the reaction layer of the condensed phase are taken into account, and stability criteria obtained under the assumption that the chemical reaction zone in the condensed phase and all of the processes in the gas phase are without inertia. Novozhilov used a more general consideration of the problem to show that the stability region is determined by only two parameters: Zel'dovich's k and the partial derivative r of the surface temperature with respect to the initial temperature at constant pressure: $r = (\partial T_1 / \partial T_0)_p$. Combustion is always stable if $k < 1$. If $k > 1$, combustion is stable only when $r > (k-1)^2 / (k+1)$

There is a general impression that a cylindrical, expanding detonation wave cannot be a steady detonation wave and at the same time fulfill the Chapman-Jouguet (C-J) condition, and that a cylindrical diverging detonation is steady only if it is supersonic with respect to its rear. To investigate these problems, Brossard et al (Ref 13) analyzed data on cylindrically diverging detonation waves in various propane/O₂/N₂ mixtures contained in divergent sectors. Detonation was initiated with an exploding wire located in the apex of the sector angle. The wave velocity was measured with ionization probes, and the wave structure was observed by means of streak-schlieren and soot-track techniques

The velocity of propagation did not change notably with distance traveled but could be higher or lower than the C-J velocity. Plots of O₂ or N₂ content vs sector thickness, h, showed that the range of stable self-sustained detonations widened as h decreased. (In tubes, on the other hand, stability increases with increase in tube diameter). Between a region of stable, self-sustained detonation on a graph and the regions of no detonations, there were intermediate regions where detonations were self-sustained but unstable. Detonation velocities fell rapidly very near the limits, and instability phenomena such as striae at very high frequencies, or series of successive waves, were observed in the structure of the detonation front

Despite Eyring's conclusion (Ref 3), Dr Donna Price stated (Ref 14, p 698) that in her "Group 1" (which includes most organic high expls such as RDX, PETN and TNT) the homogeneous processes rather than the heterogeneous ones (such as noted by Eyring) play the major part in the transmission, if not the initiation, of detonation (Ref 23)

A number of papers on stability and instability of detonation, etc were presented at the 12th Symp Combstn in 1968 at Poitiers. They are listed here as Refs 15 to 22, incl. Of these papers the one by Erpenbeck (Ref 22) critically reviews various theoretical

discussions on the stability of steady, one-dimensional finite reaction rate detonations to three-dimensional disturbances. The discussion includes: 1) the general theory and its application to certain idealized detonations 2) the stability of the square-wave model and 3) the application of acoustic-ray tracing to steady detonations and its relation to stability. Erpenbeck concluded that at present only the general theory has been fruitful in differentiating stable from unstable detonations

Refs: 1) Ya.B. Zel'dovich, ZhEkspteor-Fiz **12**, 498 (1942) 2) A.F. Belyaev & A.E. Belyaeva, DoklAkadN **50**, 299-301 (1945) & CA **44**, 10323 (1950) 3) H. Eyring et al, ChemRevs **45**, 69-181 (1949) & CA **43**, 8139 (1949) 4) Cook (1958), 216 (Stability of a shock wave in an inert solid) 5) Baum, Stanyukovich & Shekhter (1959), 259-67 (Predel'nyiia usloviya ustoychivosti detonatsii) (Limiting conditions of detonation stability) 5a) M.W. Evans & C.M. Ablow, ChemRevs **61**, 166-68 (1961) (Stability of waves in which reaction is not complete) [Papers of R. Schall, ZAngewPhys **6**, 470 (1954) and ComptRend-CongrInternationalChimieIndustrielle, Bruxelles, Belgium (1954) are discussed] 6) Ya.B. Zel'dovich, ZhPrinklMekhan i TekhnFiz (**1963**), No 1, 67-76 (Jan-Feb) (Stable combustion of powder in semiconfined space) (English translation is available) 6a) V.V. Pukhnachev, Ibid, No 6, 66 (1963) (Stability of C-J detonation) 7) K.K. Andreev & V.V. Gorbunov, VsesoyuznoyeKhimicheskoyeObshestvo, Zhurnal **8**(5), 592 (1963) (Effect of pressure on combustion stability of explosives) 8) S.S. Novikov & Yu.S. Ryazantsev, ZhPrinkl i TekhnFiz (**1965**) No 1, 56-61 (On the theory of combustion stability of propellants) 9) B.V. Novozhilov, Ibid, (**1965**), No 4, 157-60 (1965) (Stability criterion for steady-state propellant combustion) 10) I.G. Cameron & H.H.M. Pike, "The Instability of an Interface Between Two Fluids under Variable Normal Acceleration", 4thONRSympDeton (1965), pp 305-15 10a) L.A. Elliot, "Calculation of the Growth

of Interface Instabilities by a Lagrangian Mesh Method", *Ibid*, pp 314-20 11) E.K. Dabora et al, "The Influence of a Compressible Boundary on the Propagation of Gaseous Detonations", 10th Symp Combstn (1965), 817-30 12) S.K. Aslanov, IVUZ (IzvVysshikhUchebnZavedenii) AviatsionnayaTekhnika Vol 9(3), 85-88(1966) (Instability criterion for developing deflagration and an analogy of the combustion process in a detonation wave and a rocket motor) 13) J. Brossard et al, "Propagation and Vibratory Phenomena of Cylindrical and Expanding Detonation Waves in Gases", 11th Symp Combstn (1967), 623-33 14) Donna Price, "Contrasting Patterns in the Behavior of High Explosives", *Ibid*, 693-702 15) L. Crocco, "Research on Combustion Instability in Liquid Propellant Rockets", 12th Symp Combstn (1968) (Pub 1969), pp 85-99 16) E.W. Price, "Recent Advances in Solid Propellant Combustion Instability", *Ibid*, pp 101-13 17) G.A. Marxman & C.E. Wooldridge, "Finite-Amplitude Axial Instability in Solid Rocket Combustion", *Ibid*, pp 115-27 18) B.T. Zinn & C.T. Savell, "A Theoretical Study of Three-Dimensional Combustion Instability in Liquid-Propellant Rocket Engines", *Ibid*, pp 139-47 19) R.J. Priem & E.J. Rice, "Combustion Instability with Finite Mach Number Flow and Acoustic Liners", *Ibid*, pp 149-59 20) M. Barrère & F.A. Williams, "Comparison of Combustion Instabilities Found in Various Types of Combustion Chambers", *Ibid*, pp 169-81 21) M.W. Beckstead et al, "Combustion Instability of Solid Propellants", *Ibid*, pp 203-11 22) J.J. Erpenbeck, "Theory of Detonation Stability", *Ibid*, pp 711-21 23) A.G. Istratov et al, "On the Stability of Shock and Detonation Waves in Arbitrary Media", *Ibid*, pp 779-90 24) C.G. Dunkle, private communication, Jan 1969

Detonation (and Explosion), Stability of Explosives. Andreev & Belyaev (Ref 1, p 106) stated that *stability of explosive* (stoykost' vzryvchatogo veshchestva) is determined by the rate of changes in its physical and chemical (and consequently of explosive) properties with duration of time. The smaller the rate, the more stable is explosive and vice versa

There are two types of stabilities: chemical and physical

1) *Chemical Stability* is characterized by the rate of decomposition of expl as a result of chemical changes. The most common is thermal stability which can be detd either at low temps (such as temps encountered in storage) or at higher temp. Results of heat tests can be tabulated and graphically represented by two methods. In the 1st method (See Fig, curves a) the time required for formation of a known quantity, χ_1 , of products of decomposition is determined, while in the 2nd method (See Fig I, curves δ) the amount of products of decomposition χ_2 during fixed time t_2 is detd. Curves I & II deal with two different expls

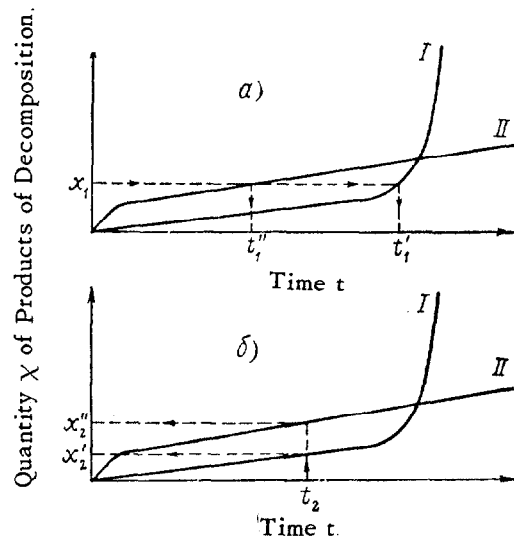

Fig 1 Two Methods of Graphical Presentation of Chemical Decomposition of Explosives

The following *chemical stability tests*, described by Andreev & Belyaev on pp 113-25, are similar to the following tests described in Ref 2 or Ref 3: Ignition or Explosion Temperature Test (Ref 2, p XVI & Ref 3, pp 7-8); German Type Heat Tests at various temperatures (Ref 2, p XV - 132°, 120°, & 134.5° Heat Tests; Ref 3, pp 23-5, 120° and 134.5° Heat Tests; Vlassov recommends conducting the test at 115° for some artillery propellants); Bergmann-Yunk Test (Ref 2, p VII1); Litmus Paper Test (or Vieille Test), described in Ref 1, p 115, mentioned in Ref 2, p XV under Heat Tests); Will's Test, described in Ref 1, pp 110-11 and listed in Ref 2, p XV under Heat Tests); Loss of Weight on Heating to 75° or 95°, described in Ref 1, p 110, corresponds to International 75° Test described on p XVIII of Ref 2 and p 18 of Ref 3. The 100° Heat Test described on p 19 of Ref 3 is also based on determination of loss of weight; Obermüller Method, based on manometric determination, described in Ref 1, pp 117-18 and listed in Ref 2, p XV, under Heat Tests; Vacuum Stability Tests described in Ref 1, p 118 are the same as described in Ref 2, p XXVI and Ref 3, pp 19-22; Taliani Test, described in Ref 1, p 119 is also described in Ref 2, pp XXIV-XXV and in Ref 3, pp 25-27; Hansen Test (or Hydrogen Ion Concentration Test), described in Ref 1, pp 119-20 is not described in Refs 2 and 3; Abel Test or KI-Starch Heat Test, described in Ref 1, pp 120-22 is described in Ref 2, p A2 and in Ref 3, pp 19 & 27; British Test, known as Silvered Vessel or Waltham Abbey Test, described in Ref 1, p 122 and Ref 2, p XXIV but not in Ref 3; Time Required for Complete Melting of Explosive Test, described in Ref 1, pp 122-23 but not described in Refs 2 & 3; *Lambrey Test*, described in Ref 1, pp 123-25 but not described in Refs 2 or 3 was designed to test the material at low temps encountered in storage at various time intervals. This is achieved by determining minute quantities of nitrogen oxides evolved on decomposition, using "optical density" method.

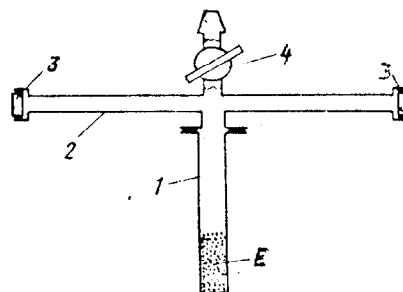

Fig 2 Apparatus of Lambrey for Testing Chemical Stability of Explosives

The apparatus used by Lambrey is shown on Fig 2. It consists of a glass tube, 1, in which is placed 8.5 g expl sample E. To the flat neck of the tube is attached (by means of picein) to the neck of tube, 2, (60 mm long), which is provided with the stopcock, 4, and two quartz windows, 3, for optical observation of nitrogen oxides density. After loading the tube, 1, with expl and assembling it together with tube, 2, the system is connected thru 4 to a vacuum pump in order to remove any gases or volatile materials adhering to the surface of expls or proplnts. After evacuation lasting as long as 120 hrs, the tubes are filled with pure carbon dioxide, the stopcock is closed and the apparatus is placed in a thermostat at a desired temperature. Carbon dioxide is added because it was found that its presence permits the determination of optical density of N oxides even if their pressure is as low as 0.015 mmHg. After one or several hours (or days), the spectra of absorption of N oxides are photographed and results are tabulated and plotted, as pressure of N oxides vs time of storage. *Radiochemical Method*, using a nitroester marked with radioactive carbon C¹⁴, is only briefly outlined in Ref 1, pp 124-25, but not described in Refs 2 or 3

Following tests are described in Ref 2, but not described in Refs 1 & 3: p XXI - Resistance to Heat Test (Épreuve de la résistance à la chaleur) is French "Official" test for detn of stability of NC and smokeless proplnts; pp XXII-XXIII - Sensitivity to Flame, Heat, Sparks, Electro-

static Discharges, etc; and p XXIV - 78°C Surveillance Test

Following tests are described in Refs 2 & 3: 75° International Test (Ref 1, p XVIII & Ref 3, p 18); 65.5° & 80°C Surveillance Tests (Ref 1, p XXIV & Ref 2, pp 22-23)

2) *Physical Stability* is characterized by the tendency of an explosive to physical changes, which might take place either by influence of external forces or by itself (such as a spontaneous decomposition), without noticeable outside influence

The following *physical stability tests* are listed in Ref 1, pp 125-29: Caking in Storage, such as observed in AN based expls (pp 126-27); Hygroscopicity (pp 127-28 and Ref 2, p XVI); and Volatility (p 125 and Ref 2, p XXVI)

In Ref 3 is also described on pp 29-31 the so-called *Reactivity Test*. The purpose of this test is to determine which materials might cause deterioration, or even hazard, when brought in contact (or stored together) with the explosive to test. The test involves the same procedure and apparatus as the vacuum stability test at 100°. A detailed description of the procedure is given on pp 30-31 of Ref 3

Using this test it is possible to determine *compatibility* of expls with other expls or substances, such as described in Ref 4, pp C461-C462

Refs: 1) Andreev & Belyaev (1960), pp 106-29 2) B.T. Fedoroff et al, "Encyclopedia of Explosives and Related Items", PATR 2700, Vol 1 (1960), pp VII to XXVI & A2 (Numerous refs) 3) A. Clear, "Standard Laboratory Procedures for Determining Sensitivity, Brisance and Stability of Explosives", PATR 3278 (1965), pp 17-29 and pp 29-31 (Reactivity Test)

Note: Most of the tests described in Ref 3 are also described in MIL-STD-286A,

Method 406.1.1, published by the US Govt-PtgOff, Washington, DC (1961)

4) B.T. Fedoroff & O.E. Sheffield, "Encyclopedia of Explosives and Related Items", PATR 2700, Vol 3 (1966), pp C461-C462 (Compatibility of Explosives with Other Substances)

Detonation, Stable. Same as Detonation, Stationary or Detonation, Steady

Detonation, Standing Wave. See "Standing Detonation Wave", under DETONATION WAVES

Detonation, Stand-off in Jet Penetration. See under Detonation, Munroe-Neumann Effect and also in Cook (1958), p 258

Detonation (and Explosion) State Properties of Explosives. Accdg to Dunkle (Ref 2), properties (such as pressure and volume) which are defining a thermodynamic state are known as *state properties of explosives*

Accdg to Cook (Ref 1, p 305), it is important when dealing with expln-state, to determine the composition of gases (such as CO/CO₂, NO, HCN, CH₃, NH₃, etc) and the values: T₃ (temp of expln °K x 10⁻³), A (max available energy) & Q (heat of expln, kcal/g), more accurately than when dealing with "detonation-state properties" (see in this section). This is because expln-state props are strongly dependent on the above values. A brief discussion on determination of compn of expln products is given on pp 305 & 306; Table 12.18, pp 307-10 gives expln-state props for various commercial and military expls, including TNT, 50/50-Amatol, 80/20-Amatol, PETN, RDX, NG, Tetrayl, 60% & 40% Straight Dynamites, 100%, 75%, & 40% Straight Gelatins, 75% & 40% Ammonia Gelatins, Semigelatin, Nitrostarch Powder, Extra or AN Dynamite, AN-A1-Water Expls, 94.5/5.5-AN/Fuel Oil, 85/15-AN/DNT & 87.5/12.5-AN/Wood Pulp

The computation of the ideal detonation or Chapman-Jouguet properties is sufficiently insensitive to the products of detonation, such as CO, CO₂, NO₂, etc and that one may, with sufficient accuracy, interpolate and extrapolate to obtain n (mols gas/kg), Q (heat of deton, kcal/g) & C_v (heat capacity at const vol (kcal/kg/°K) over a considerable density range from compns computed at a few selected densities.. Another way is to det compn of products by less accurate computations, e.g., by neglecting gases such as CH₄, NH₃, CH₃, CH₃OH, CH₂O₂ & HCN. Cook, Jones & other investigators have shown that the major deton props, including velocities (D) can be fairly accurately calcd using the simplified methods mentioned above. Table 12.17, p 306 of Ref 1 lists detonation props of Comp B, 70.7/29.3-Comp B/AN, 50/50-TNT/AN, DNT, Blasting Gelatin, 60% Dynamite and 94.5/5.5-AN/Fuel Oil. Appendix II, pp 379-407 gives details of calculations of products of detonation and tables of detonation-state properties

Using $\alpha(v)$ equation of state Cook (Ref 1, p 284, Table 12.1) gives explosion state and other properties for some primary and near primary explosives, which include MF, LA, HNMnt, NG, EGDN, PETN, RDX and Tetryl. The $\alpha(v)$ equation of state is listed on p 37 of Cook and as item e, in Section 3 under "DETONATION (AND) EXPLOSION),

EQUATIONS OF STATE IN

Refs: 1) Cook (1958), 37, 305-21 & 379-407
2) C.G. Dunkle, private communication, Jan 1969

Detonation, Stationary or Stable. Same as Detonation, Steady or Uniform

Detonation, Steady and Nonsteady State in (Steady Flow or Streamline Flow and Nonsteady State in). This is the case when every particle that flows past a fixed point in space will have the same \vec{q} , ρ and P at that point independent of time. In this condition, every point of the fluid continuum has a corresponding fluid velocity vector \vec{q} . The term *streamlines* signifies a family of curves which are everywhere tangent to \vec{q} ; thus, the direction of each streamline is everywhere that of the motion of the fluid

In *unsteady flows*, the streamline pattern changes from instant to instant. In "steady-state" flux the streamlines are constant in time and also represent the *path lines*, the trajectories of the fluid particles (Ref 1, p 18)

Evans & Ablow (Ref 2) defined the *steady-flow* as "a flow in which all partial derivatives with respect to time are equal to zero". The five equations listed in their paper (p 131), together with appropriate initial and boundary conditions, are sufficient to solve for the dependent variables: \vec{q} (material or particle velocity factor), P (pressure), ρ (density), e (specific internal energy) and s (specific entropy) in regions which are free of discontinuities. When dissipative irreversible effects are present, appropriate additional terms are required in the equations

A *steady flow* can be *subsonic*, *sonic* or *supersonic* at a point as the magnitude of flow velocity \vec{q} at that point is less than, equal to, or greater than the sound velocity c at that point, in the particular coordinate system being used

Additional information on "unsteady flow" is given in Refs 3 & 4

Note 1: Dunkle (Ref 1, p 259) remarked that the term "uniform" can be used instead of "steady"

Note 2: Dunkle (Ref 5) remarked that the "ideal or Chapman-Jouguet detonation" is a steady-state process, and that the derivation of the Hugoniot equations is based on the process being steady-state, so that the mass velocity \dot{m} (rate of mass flow per unit area per unit time) is constant thruout the (one-dimensional) process.

(See also "Detonation Waves, Steady and Unsteady")

Refs: 1) Dunkle's Syllabus (1957-1958), 18, 168-69 & 259 2) M.W. Evans & C.M. Ablow, ChemRev 61, 131 (1961) 3) A. Vidart et al, "Calculations of Unsteady 2-D Flows by Various Numerical Methods", 4thONRSympDeton (1965), 527-37 4) P.H. Kydd, "Analysis and Experiments on Unsteady Flow in Gas Turbine Main Combustors", 12thSympCombstm (1968) (Pub 1969), pp 183-92 5) C.G. Dunkle, Private communication, Jan 1969

Detonation, Steady and Nonsteady State of Penetration of Targets by Lined-Cavity Jets.

The hydrodynamic theory of the penetration of targets by lined cavity jets was developed, according to Cook (Ref 7, p 252), independently by Pugh (Birkhoff's et al Ref 2) and by Hill et al (Ref 1). Pack & Evans (Refs 3 & 4) discussed the *steady-state* theory of penetration in which the jet-velocity distribution was ignored and the penetration velocity was assumed constant. Pugh & Eichelberger (Refs 5 & 6) discussed the *nonsteady-state* of jet penetration in which the actual velocity distribution in the jet was taken into account as well as the variation of the velocity of penetration with depth. These theories are discussed by Cook (Ref 7)

Refs: 1) R. Hill, N.F. Mott & D.C. Pack, Unpublished "Ministry of Supply" Report, January 1944 2) G. Birkhoff, D.P. MacDougall & D.P. Pugh, *JApplPhys* **19**, 563 (1948) 3) D.C. Pack & W.M. Evans, *PrPhysSoc* (London) **64B**, 298 (1951) 4) W.M. Evans & D.C. Pack, *PrPhysSoc* **64B**, 303 (1951) 5) E.M. Pugh, R.J. Eichelberger, & N. Rostoker, *JApplPhys* **23**, 532 (1952) 6) R.J. Eichelberger, "Re-examination of Theories of Jet Formation and Target Penetration by Lined Cavity Charges", Carnegie Institute of Technology, Dept of Physics, CEL Rept No. 1, June 1954 & *JApplPhys* **27**, 63 (1956) 7) Cook (1958), 252-55

Detonation, Strain Waves in Rock.

Such waves are described under the title: "Generation and Propagation of Strain Waves in Rock", L. Obert & W.I. Duvall in USBur-

Mines Report of Investigation **TI 4683** (1950)

Note: Since "strain" is defined in dictionaries as "any force or pressure tending to cause a mechanical deformation in a body or structure as result of stress" and since Cook (1958), describes on p 339 the item "Shock-Wave (or Stress-Wave) Fracturing of Rock", we might consider that a strain can be caused by shock similar to that caused by stress

[See also in this Vol: "Detonation, Shock Wave (or Stress Wave) Fracturing of Rock in"]

Detonation, Streamline Flow. See under "Detonation, Steady and Nonsteady Flow in"

Detonation, Strong and Weak. This subject is discussed by Evans & Ablow (Ref 2, pp 141-42), but prior to this it is necessary to discuss the "existence and uniqueness of classes of reaction waves for specific boundary conditions", as given in the book of Courant & Friedrichs (Ref 1, pp 215-22) and in Ref 2

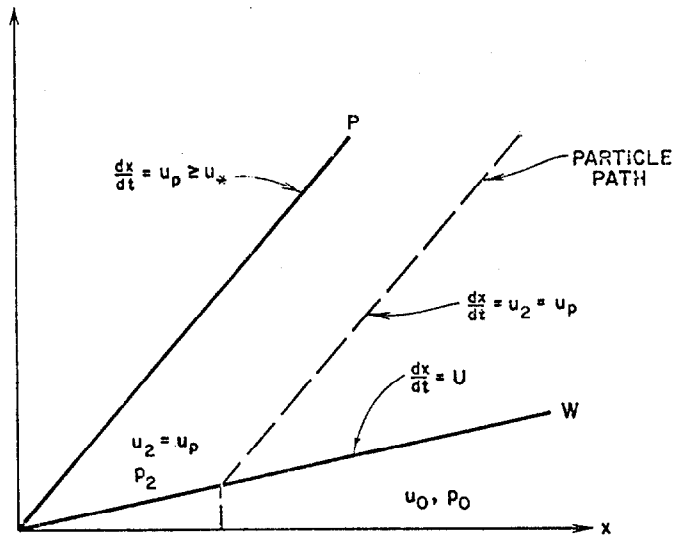

FIG 1 Flow in a strong detonation. Piston path (P), detonation front (W), and particle path (dashed) are shown

Let the rear boundary of reaction wave move with a specific velocity u_p along the line P in the x,t -plane as in Fig 9 of Ref 2 (our Fig 1). Then initial data are prescribed along two lines. One is the x -axis, which is spacelike with respect to the material behind it and carries the quantity $u=0$ (if the material is initially at rest), and $p=p_0$. The other line is P, which is timelike, or subsonic to the gas flow, since it is identical with the path of the adjacent gas particles; it carries velocity u_p . The discontinuity of the reaction wave is represented by the line W. The deductions on uniqueness which can be used for non-reactive flow (See Ref 2, pp 136-37) cannot be applied here directly because of the interference of the unknown discontinuity W.

They can, however, be applied separately to the sectors between the x-axis and W, and betw W and P. There are four cases, according to whether the flow relative to W is supersonic or subsonic before or behind the front. The directions of the characteristics on either side of W relative to the direction of W determines which case applies.

Accdg to Jouguet's rule for detonations, the W is spacelike or subsonic when observed from the region ahead of it. Thus, betw W and the x-axis the flow is uniquely determined by the x-axis and the quantities prescribed on it, so that $u = u_0$ and $p = p_0$ everywhere in that sector. For a *strong detonation* W and P are subsonic, i.e., timelike, with respect to the region behind them and the flow betw W and P is uniform. As there is only one slope of W, the flow for strong detonation is completely detd by the initial conditions and the piston velocity. A strong detonation results when the piston velocity $u_p > (u_2)_*$, where $(u_2)_*$ is that particular value of the gas velocity behind the gas front which satisfies the C-J condition. For $u_p = (u_2)_*$, the strong detonation becomes, as a limit, a C-J detonation. The flow in a strong deton presented in Fig 1 shows the initial data line or piston path P, the reaction front W, and a particle path.

Weak detonations arise when $u_p < (u_2)_*$. Accdg to Jouguet's rule, the flow relative to the reaction front in a weak detonation is supersonic both ahead of and behind the reaction wave. Since one curve, P, is timelike and another, W, is spacelike, the solution for the flow betw the two curves is unique only in one quantity which is prescribed on P and two quantities prescribed on W. It is now possible for the velocity of W to be chosen arbitrarily, subject only to the condition that it be supersonic, and there is one degree of indeterminacy. Figs 2a and 2b show two possible solutions for a flow which the curve P and the initial conditions u_0, p_0 are given. In the sector bound by W and C_+^0 where C_+^0 is the characteristic issuing from the point $x=0$ & $t=0$, the flow is supersonic and constant and is detd by the slope of W, as in Fig 2a. The transition

from constant flow to simple wave takes place across C_+^0 , along which $u = u_2$ & $c = c_2$. This flow must adjust thru the centered simple wave to the piston path P, along which the material velocity u_p is prescribed. In the simple wave $u - c$ is constant thruout, $u - c = u_2 - c_2$, while $u + c$ varies but has a fixed value along each C_+ characteristic.

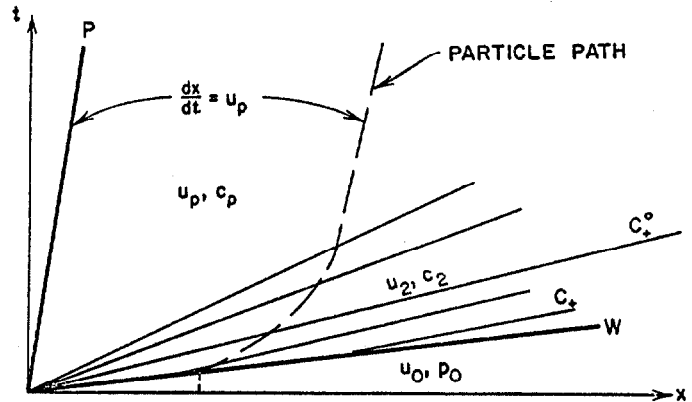

(a)

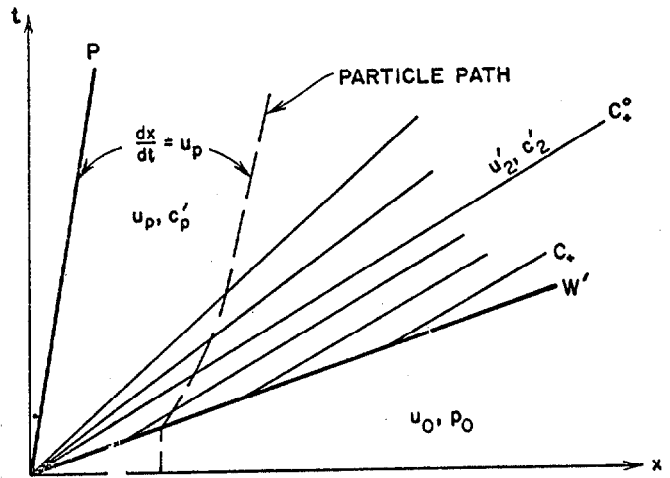

(b)

FIG 2 Two possible weak detonation solutions for given P and u_0, p_0

Thus the sound speed along the piston for this solution of the flow will have the value $c_p = u_p - u_2 + c_2$, and the pressure p_p and density ρ_p will have appropriate values of state, such as detd by eq:

$$\frac{(P_2 - P_0)}{(u_2 - u_0)} = -P_0 v_0 = -P_2 v_2$$

Another possible flow for weak detonation is that of Fig 2b, where a different detonation front curve W gives values u_2^1 and c_2^1 along the characteristics in the sector between W and C_+ . For this flow the value of c_p along P will be $c_p^1 = u_p - u_2^1 + c_2^1$ and the value of p along P will also be different from that of the first solution. One of the possible flows is that for which both the front and the first sound wave move with sonic velocity relative to the gas behind the front. Such values are designated by a subscript *, so that for this flow $u_2 = (u_2)_*$ and $c_2 = (c_2)_*$. The hypothesis that the flow which occurs is the C-J detonation is the *Chapman-Jouguet hypothesis*. For such a detonation, equation 3.2,12 (p 140 of Ref 2) applies and W & C_+ coincide, as is shown in Fig 3.

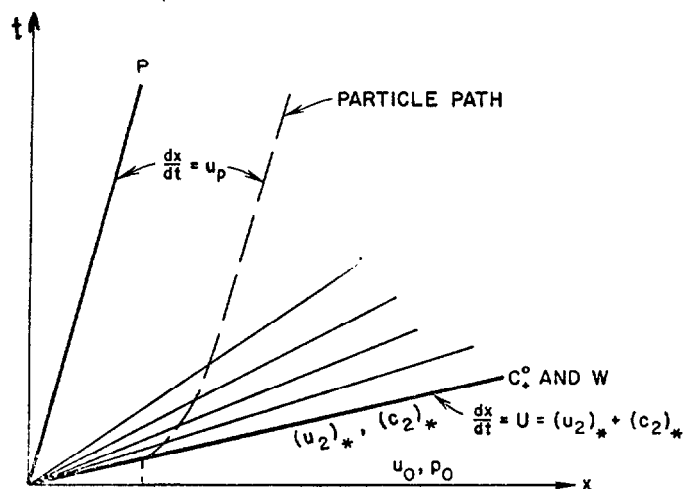

FIG 3 Flow in a Chapman-Jouguet detonation

For the special case where $u_p = (u_2)_*$, the rarefaction wave drops out

Refs: 1) R. Courant & K.O. Friedrichs, "Supersonic Flow and Shock Waves", Interscience, NY (1948), 215-22 2) M.W. Evans & C.M. Ablow, ChemRevs **61**, 141-42 (1961)

Detonation, Structure of Some Liquid Explosives in was discussed by T.P. Cotter in his Thesis, Cornell Univ, Ithaca, NY, Sept 1953

"Detonation Studies in Electric and Magnetic Fields". Title of the paper presented by F.E. Allison at the 3rdONRSympDeton (1960), pp 112-19

Detonation, Supercompressed Developed in Constricted Tubes. Studies in Russia showed that in uniform (nonconstricted) wide or narrow tubes, the velocity of propagation increased, at the moment of transition into detonation, from a relative value of 0.38-0.43 to a relative value of 1. When propagation was initiated at the wide end of a constricted tube 80 cm long, consisting of a 50 cm section 4.5-5.0 cm in diam and a 30 cm section of 0.8-1.0 cm in diam, calculation for reflected and transitional waves indicated that in the narrow section the pressure in the reflection was 2.5 greater than in the wider tube

Ref: B.V. Aivazov & Ya.B. Zel'dovich, ZhEkptlTeoretFiz **17**, 889-900 (1947) & CA **45**, 10587 (1951)

Detonation, Supported Shock Wave in. See under DETONATION (AND EXPLOSION), SHOCK WAVE IN

Detonation, Supercelerity (or Hypervelocity) in. When a detonation propagates at rates above normal it is known as *supercelerity* or *hypervelocity* of detonation. Such a detonation may also be called *overdetonation* or *overdriven detonation*. This shows that velocity can propagate not only at *low velocity* as described under "Detonation, High-, Low-, and Intermediate Order Velocities of", but also at supercelerities

In Dunkle's Syllabus (Ref 7, p 259) it is stated that the *overdriven wave* can be defined as one "moving at higher than normal velocity"

Penney (Ref 1, p 3) stated that in any freely running detonation, the velocity must obey the Chapman-Jouguet condition, but if the explosive products are forced forward by a constraint which moves at a velocity greater than $(D-c)$, where D and c are the

free running detonation velocity and the velocity of sound at the end of the reaction zone in free detonation, the detonation velocity will increase beyond the free-running value. A conceivable method by which the deton wave in an explosive can be *overdriven* is to start the detonation by means of a more powerful expl with a higher deton velocity. The dynamical condition which must be fulfilled if one expl is to be capable of overdriving another is easily formulated, but it is not given by Penney. As an example of a pair of such expls, however, it is remarked that if a stick of RDX/TNT is placed end-on to a similar stick of straight TNT and deton proceeds from the former to the latter, one would expect for a short distance, at least, that the detonation in the TNT would be faster than normal

Dunkle stated (Ref 7, p 281) that a higher rate of detonation is a general result when the deton front is concave forward. Poulter (Ref 5) reported that studies at SRI of the velocity of convergent detonation fronts have indicated a relationship in the following form:

$$V_R = V_\infty e^{C/R}$$

where V_R = velocity of a front which is concave forward with a spherical radius of curvature R , and V_∞ is the velocity for infinite radius of curvature or a plane wave. If R is expressed in mm, C has the value of 4.78 in the case of Comp B

In Dunkle's Syllabus (Ref 17, p 11g) it is stated that *super-detonation velocity regimes* are of two types: In one, the pre-compressed medium simply becomes heated to the point where ignition delay is so short that the flame appears virtually at the shock front. If there is any gap between them, when the temp is reached, the flame jumps it at once. Such a gap is made possible as Cook et al suggest, by a sudden increase in thermal conductivity accompanying a sudden upsurge of ionization as a certain temperature limit is expected. The energy released in such a fast-traveling process might be only that given by the combustion process rather than that corresponding to a shock wave moving at that speed

In the other type of *hypervelocity process*, there is actually a supervelocity detonation front (Ref 10) of greatly enhanced destructiveness (Ref 6). The effect seems greatest if the front is not established until most of the mixture has been precompressed and "processed". The processing under these conditions seems to include considerable chemical reaction and, hence, partial release of energy. This should leave less energy to be evolved in the final chemical reaction. It is interesting, therefore, that the "brisance" of the process is not lower but higher. On the other hand, as soon as the precompressed material is used up so that the deton front begins to propagate directly into previously undisturbed material, the detonation rate and effectiveness drop back to their usual values (Ref 17, p 11g)

Sargent & Gross (Ref 11) reported the performance of a hypersonic ramjet having a detonation wave combustion process. Flight speeds of Mach 2.5 to 10 were examined and compared to those of a conventional ramjet. Performance was better than could be expected, because even with large inlet and wave total pressure losses, at high Mach number the overall cycle pressure ratio was well matched to the temp ratios obt'd by combustion (Ref 17, p 11g)

Majowica & Jacobs (Ref 16) reported a jump (overshoot) from below to normal detonation velocity in a number of cased expls; in other expls the velocity grew continuously from a low value to that of normal deton. Both gradual buildup and overshoot were explained by use of hydrodynamic theory supplemented by reaction kinetics (Ref 17, p 23d)

Holland et al (Ref 4) observed hypervelocity wave phenomena during initiation by direct shocks in single crystals of PETN and liquid NMe. They observed by means of streak camera photography of shock impacted large crystals of PETN that the growth of detonation towards the steady-state apparently proceeded in several stages. First, a relatively low velocity wave front (5.56 mm/ μ sec) appeared which abruptly changed to a very high compressed wave (ca 10.45 mm/ μ sec). Within ca 0.5 μ sec, the high-velocity front

changed to an apparent steady-state detonation (8.28 mm/ μ sec), which consumed the crystal. No explanation was given as to the nature of these events

From similar space-time high-speed camera studies of the shock initiation to detonation of NMe, Cook et al (Ref 9) observed a *flash-across* phenomenon in which an apparent wave of luminescence originated in the explosive behind the initial compression front and propagated at a reported velocity of 35 mm/ μ sec to overtake the initial compression front. This "flash across" phenomenon was interpreted as a heat transfer wave caused by a sudden increase in the thermal conductivity of the shock-compressed NMe. The phenomenon was taken as a direct observation of the "heat pulse", which Cook et al had predicted in 1955 (Ref 2)

Sometime prior to 1959, Chaiken carried out a streak camera study of the shock initiation of NMe (Ref 14). At that time, evidence was found to indicate the existence of a hypervelocity wave moving behind the initiating shock front. It was suggested that the detonation reaction wave originated behind the initial compression front, and traveled at a "super-velocity" in the compressed explosive to overtake the initiating shock front. Chaiken (Ref 15) believed that the hypervelocity wave arising behind the initiating shock front might explain both the "flash-across" phenomenon observed by Cook et al (Ref 9) and at the same time offer an explanation for the velocity steps observed by Holland et al (Ref 4) in detonation of PETN. The velocity, D_s , observed by Chaiken for NMe, agreed with the equation:

$$D_s = 2.78 \times 10^3 \rho_1 + 3110 \text{ m}/\mu\text{sec}$$

where ρ_1 = shock density, estimated as 2.1g/cc. This gave for D_s 8.86 m/ μ sec. Adding on the particle velocity, since the reaction would be propagating in a moving medium, there is obtained $D^i = D_s + 11.5 \text{ m}/\mu\text{sec}$. The formation of such hypervelocity is in accord with the existence of a time lag or apparent induction time. At the end of this period, the molecules of explosive which were first compressed by the initiating shock front suddenly decompose. The

rapid release of energy propagates a high pressure reaction wave which overtakes the initiating shock and passes into the unshocked region. Here it is highly *overboosted*, propagating with a higher than steady-state velocity, but the deton front rapidly decays to its normal steady-state value (Ref 17, p 23e)

Additional evidence for the formation of a hypervelocity reaction wave behind the initiating shock front was given by Hubbard & Johnson (Ref 12). Hydrodynamic motion and the release of chemical energy appeared to be practically independent processes. Calculations were made for typical pressure pulses by the use of the time-dependent one-dimensional hydrodynamic equations with an Arrhenius form of energy release. These suggest, in view of the extreme temperature-sensitivity of the reaction, that the chemical energy release has no effect on the hydrodynamics until burning begins. Thereupon, the burning is so rapid that it is not influenced by the hydrodynamics. A criterion was formulated for the initiation of detonation, in terms of a delay time such that, if any point in the expl remained at a given temp for longer than the corresponding delay time, a detonation wave was initiated (Ref 17, p 23e)

Mathematical background of supervelocity phenomena was given (besides by Chaiken and Hubbard & Johnson) by Campbell et al (Ref 3)

Refs: 1) W.G. Penney, *PrRoySoc* **204A**, 4 (1950) (Overdriven deton) 2) M.A. Cook et al, *TrFaradSoc* **52**, 363 (1955) 3) A.W. Campbell, et al, *JApplPhys* **27**, 963 (1956) 4) T.E. Holland et al, *JApplPhys* **28**, 1212 (1957) 5) T.C. Poulter, "A Report on Recent Basic Studies on Detonation of High Explosives", SRI (Stanford Research Institute), Poulter Laboratories, LabTechRept **010-57** (1957) (Conf) (Unclassified paper on pp 82-92) 6) B.B. Jacobs et al, *ChemEngrg-Progress* **23**, 565-73 (1957) (Destruction of a large refinery unit by gaseous detonation) 7) Dunkle's Syllabus (1957-1958), pp 259 & 281 8) Cook (1958), p 153 (Overdriven shock wave) 9) M.A. Cook et al, *PrRoySoc* **246A**, 281-83 (July 1958) (Deflagration to detonation transition in liquid expls) 10) I. Ginsburgh, *JApplPhys* **29**, 1381-82

(Sept 1958) (Abnormally high deton pressures in a shock tube) 11) W.H. Sargent & R.A. Gross, "A Detonation Wave Supersonic Ramjet", AFOSR 59-589, ASTIA 216811 (June 1959) 12) H.W. Hubbard & M.H. Johnson, JApplPhys 30, 765-69 (May 1959) (Initiation of detonations) 13) M.A. Cook et al, "Deflagration to Detonation Transition", 7thSympCombstn (1959), 820-36 14) R.F. Chaiken, "The Kinetic Theory of Detonation of High Explosives", MS Thesis, Polytech Institute of Brooklyn (1958); submitted to the 8thSympCombstn (1962), pp 759-67 15) R.F. Chaiken, "Comments on Hypervelocity Wave Phenomena in Condensed Explosives", 3rdONRSympDeton (1960), pp 304-08 16) S.J. Jacobs, JAmRocketSoc 30, 151-58 (Feb 1960) (Recent advances in condensed media detonations) 17) Dunkle's Syllabus (1960-1961) pp 11g & 23d-e 18) H. Behrens et al, "Studies of Hypervelocity Firings into Mixtures of Hydrogen with Air or with Oxygen", 10thSympCombstn (1965), pp 245-52 19) N.I. Yushchenkova & S.I. Kosterin, "On the Effect of Kinetics of Elementary Reactions on Ionization in stationary and Nonstationary Supersonic Expansion and Compression of Gases", Ibid, pp 721-30 20) E.A. Fletcher, "Early Supersonic Combustion Studies at NACA and NASA", 11thSympCombstn (1967) pp 729-37 21) F.S. Billig, "Design of Supersonic Combustors Based on Pressure-Area Fields", Ibid, pp 755-69

Detonation, Supression of. T.F. Seamans & H.G. Wolfhard published in ACS, Div Fuel Chem, Preprints 1, 185-214 (1961) & CA 58, 11162 (1963), the paper entitled: "Detonation and Supression of Detonation in Fuel-Air Mixtures at Elevated Temperatures"

Detonation, Surface-Erosion Model of Eyring et al as Applied in. Erosive or surface-burning of explosives and propellants, including *Piombert's Law of 1839* (Das Piombertsche Gesetz von 1839), is described in Vol 2 of Encycl, pp B 343 & B 364, respectively, but unfortunately the reference of Eyring et al (Ref 3) was not included. Erosive burning of proplnts is also de-

scribed on p B 357, where 14 refs, dated from 1907 to 1959, are listed. Cook (Ref 4, p 126) in description of the *geometrical model theory*, developed by him et al, stated that: "Eyring et al formulated the familiar *surface-burning model* for solid explosives, the adoption of which in the geometrical model has been found to give results in substantial agreement with experimental observations of all types of nonideal explosives except fuel-sensitized AN explosives"

Cook also stated that the geometrical model theory was developed without his knowing that a similar theory was formulated, as early as 1928 by Roth & Wöhler and described in Roth's thesis (Ref 1). The same theory was described in 1934 by Wöhler & Roth (Ref 2). Roth referred in his description to the surface erosion in propellant burning as "Das Piombertsche Gesetz von 1839", citing as a reference Vol 2, p 120 of "Lehrbuch der Ballistik" by C. Cranz (1926)

The Eyring surface-burning model (Refs 3 & 4) assumes that the grains of solid explosives (whether loose, pressed, or cast) are exposed to the high-temperatures of detonation for such a short period of time that no appreciable heat conduction takes place into the grains. However, the surface is assumed to be in thermal equilibrium with the gas phase surrounding the grains. Hence reaction is confined to the surface of the grain and proceeds layer by layer radially inward until the grain is essentially consumed

Mathematical formulation of Eyring's surface-burning model is given by Cook on pp 126-28

Refs: 1) J.F. Roth, "Über die Prüfung der Initialwirkung von Sprengkapseln", Dissertation Technische Hochschule Darmstadt (1928) 2) L. Wöhler & J.F. Roth, SS 29, 9(1934) 3) H. Eyring et al, ChemRevs 45, 69(1949) 4) Cook (1958), pp 90, 126-28 & 142

Detonation, Susan Test in. See Refs 61 & 67, under DETONATION (AND EXPLOSION), EXPERIMENTAL PROCEDURES

Detonation, Susceptibility to. Susceptibility of expls and proplnts to detonation can be derived by consulting the following items: "Detonation (and Explosion), Initiation" and "Detonation, Sensitivity of Explosives to". See also "Investigation of Susceptibility to Detonation of Propellants", by C.M. Mason et al, PBRept 152022 (1958), 25 pp, USDept of Commerce, Ofc of Tech Services; CA 58, 12361-62 (1963)

Detonation, Susceptibility to Sympathetic. See under DETONATION (AND EXPLOSION) BY INFLUENCE

Detonation (and Explosion), Sympathetic. See DETONATION (AND EXPLOSION) BY INFLUENCE and also under Detonation (and Explosion), Dist- ant Effect of

Detonation, Taylor Spherical Wave in. See Detonation, Spherical Taylor Wave for the Gaseous Products of Solid Explosives in

Detonation, TDBP Wave (Taylor- Döring- Burkhardt-Pfriem Wave). Accdgd to discussion given by Cook in Chapter 5, under "Theoretical Wave Profiles" (Ref 4, pp 92ff), Taylor (Ref 3) studied theoretically the $\rho(x)$ and $W(x)$ distri- butions behind plane and spherical detonation waves for gaseous expls and TNT, using the hydrodynamic equation:

$$W(x) - W_2 = \int_{\rho_2}^{\rho} C \, d \log_e \rho \quad (5.6)$$

where: $\rho(x)$ = density - distance

$W(x)$ = particle velocity - distance relations

ρ_2 = density &
 W_2 = particle velocity at Chapman- Jouguet plane

ρ = density of original explosive
 C = sound velocity

For gaseous expls in which products of deton obey the ideal-gas law, eq (5.6) may be integrated to give:

$$W = f(\rho, W_2) \quad (5.7)$$

where: W = particle velocity

In condensed expls using the $\alpha(v)$ equation of state, known also as "covolume equation of state" [described under Detonation (and Explosion), Equations of State in], Taylor obtd:

$$W - W_2 = \int_v^{v_2} \frac{(nRT\beta)^{1/2}}{v - \alpha} \, dv = W_2 \beta \int_v^{v_2} \frac{dv}{v - \alpha} \quad (5.8)$$

Here α = covolume; v = specific volume of deton products; v_2 = specific volume at C-J plane; $\beta = (v_2 - \alpha) / (v_1 - v_2)$, where v_1 = sp vol of original expl and T = temperature of detonation, °K

Equation (5.8) is applicable in the range $v_2 < v < v_1$, i.e., between the C-J plane and the stagnation plane $W(x) = 0$. The approximation in eq (5.8) is based on the observation that in this range of densities, temp T decreases during isentropic expansion at about the same rate that β increases and the product $(T\beta)$ is therefore approx constant. The integral $\int_v^{v_2} dv / (v - \alpha)$ is apparently the same for a given initial and final density for at least most condensed expls since $\alpha(v)$ is the same function of v for these expls. Thus it is evident that the condition in eq (5.7) applies to condensed as well as gaseous expls and $W(x)$ and $\rho(x)$ may thus be studied in the general case by observing simply the $\rho(x)$ distribution. That is, $p(x)$, $W(x)$ and $\rho(x)$ should all vary in about the same way, and the measurement of one serves thru the hydrodynamic theory to define the other two

After giving more details on Taylor's calculation, Cook stated on p 93 that similar developments have been given for gases by Doering and Burkhardt (Ref 2) and prior to them by Pfriem (Ref 1). Their equivalent theories did not take into account the influence of lateral expansion and/or heat loss. In condensed expls, edge effects prevent ideal conditions from applying more than ca one chge diam along the axis of a cylindrical chge and even shorter distances off the axis

Refs: 1) H. Pfriem, *ForschGebieteIngenieurw* 12, 143(1941) & CA 37, 6537(1943) 2) W. Doering & G.I. Burkhardt, *TechRept No*

FTS-1227-118 (GDAM 9-T-46) (1946) 3) G.I.
Taylor PrRoySoc. 200A, 235 (1949) 4) Cook
(1958), 92, 93, 94, 96, 97, 122 & 123

Section 9A

Detonation (and Explosion) Temperature and Its Determination, also called *Deflagration Temperature*-, *Flash Point*-, *Ignition Point*- or *Ignition Temperature Test* (Température de déflagration ou Point de déflagration in French; Verpuffungstemperatur in Ger; Temperatura di accensione in Ital; Temperatura de inflamación in Span and Temperatura vspyshki in Rus). It may be defined as the *minimum temperature* to which an explosive, propellant or pyrotechnic composition must be heated in order to cause its detonation (explosion, deflagration or ignition), either during a certain period of time or instantaneously. In US practice this time is usually 5 seconds, but in some cases a time as low as 0.1 sec has been reported

Detonation (and Explosion) Temperature must not be confused with Temperature of Detonation (or Explosion) described in the next item

Knowledge of detonation (or explosion) temperatures is of importance from the point of view of safety - the higher is that temperature, the safer is the explosive in storage or on handling

It might be pointed out that large masses of expls (proplnts or pyrotechnic compns) might ignite at temps lower than those detd in laboratories with small samples and reported in the literature (Ref 24, p 26)

The methods used in the US have been briefly described in Refs 1, 8, 12, 13, 17, 20, 22 & 26

A detailed description of the current US military method is given in Refs 28 & 29 and its apparatus is shown in Fig

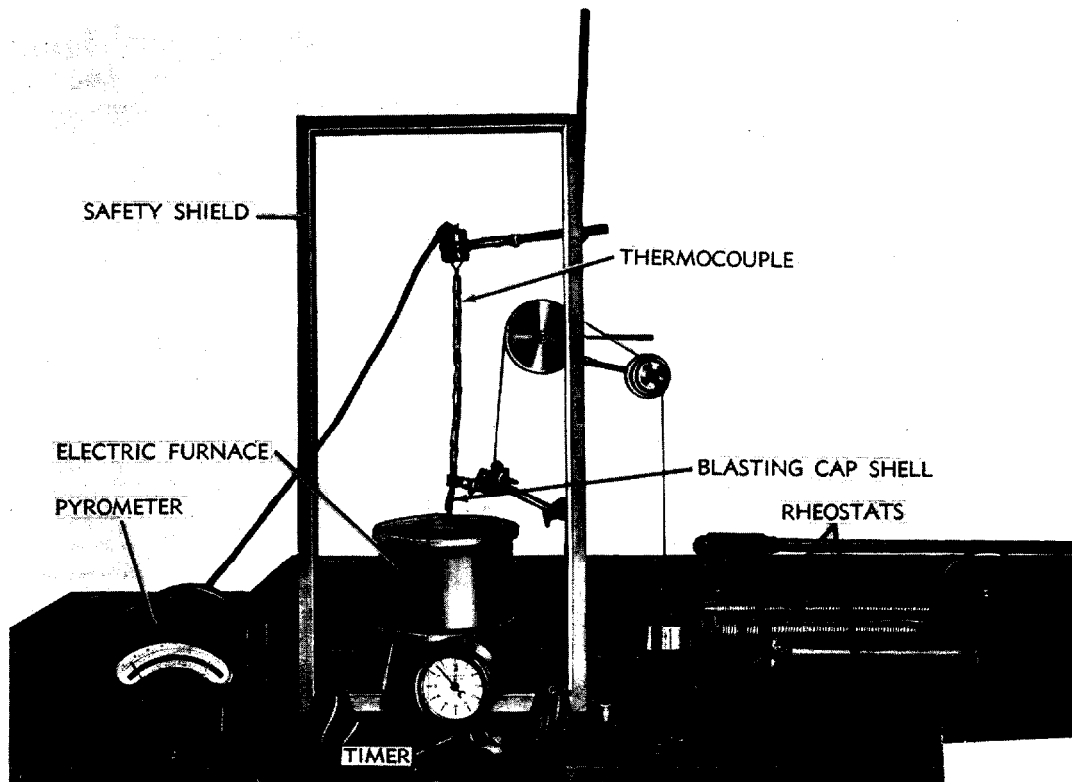

Fig. Explosion Temperature Test Apparatus

The apparatus consists of a multiple unit electric furnace equipped with a rheostat to control the temp. An iron crucible having a capacity of ca 100 cc and contg ca 75 cc of molten Wood's alloy (composed of Bi 50, Pb 25, Sn 12.5 & Cd 12.5%), which melts at 65.5°, is placed in the electric furnace. A calibrated thermocouple, connected to an indicating thermoelectric pyrometer (with a temp range from 0° to 1400°C, graduated at 10° intervals) is immersed in the molten metal in the crucible. The app is equipped with a clamp for holding No 8 commercial blasting caps, each contg ca 0.02 g of the expl that passes thru a No 50 USStd-Sieve. After placing the sample in the cap, it should be tapped to compact the expl. For initiating expls only 0.01 g samples are prescribed. When the metal in the crucible reaches the desired temp, place the shatter-proof-glass barricade in front of the apparatus, and lower (by means of a lever) the clamp to a point corresponding to the fixed depth of immersion of the cap in the molten metal. Wait until the sample puffs off (or flashes, or explodes) and record the bath temp and the time of immersion. Vary the metal temp in the bath betw detons so as to have the 10 flashes or explns occur over a time interval range of 2 to 10-secs. Plot a time-temp curve and select from this curve the temp necessary to cause the expl to flash or explode after immersion for 5 seconds. Record this temp as the expln (ignition, etc) temp

In the table which follows are listed the temps in °C which were detd in the USA by means of apparatus similar to the one described in Ref 28. The values are taken from PATR 1740, Rev (1958) and from the table entitled "Military Explosives" compiled at PicArns. The temps detd in Russia for some expls and reported in Ref 24, p 29 and Ref 25, pp 326-27 are given here for comparison

Most of the apparatuses used in foreign countries employ heated baths either filled with Wood's metal or with some liquid of high bp, such as in apparatus of Kostevitch (Refs 5 & 24). Exceptions are the apparatus of Langhans, briefly described in Ref 4, which employs a metal block and the apparatus of Belgrano (Ref 18) which employs an iron plate and is of very simple construction

In the book of Baum et al (Ref 24, pp 28-9) a description is given of two methods used in Russia. The first method employs a cylindrical vessel filled with molten Wood's metal, provided with a cover thru which passes a thermometer, and a metallic blasting cap contg 0.05 g sample. The bath is heated electrically at the rate of increase in temp of 20° per minute. The temp at which the sound is heard is recorded. Then the temp of the bath is slightly lowered and the cap with a new 0.05 g sample is plunged into molten metal. Then the minimum temp required for the sample to puff off in 5 secs is recorded. This procedure is repeated until the results check within 5 sec

In the 2nd method, using the apparatus of M.M. Kostevitch, a small sample is placed in a glass bulb and, after sealing, it is heated. The temp at which the sample puffs off within 5 secs is taken. Some of the values listed on p 29 are listed here in Table A, p D585

In the book of Baum et al (Ref 24, p 24) is also described the method of N.N. Semenov for calcn of relationship betw temperature of ignition (flash point) and induction period (delay of ignition). The relationship may be expressed by the following formula:

$$\tau = C e^{E/RT}$$

where: τ = induction period (time lag) in secs

C = constant depending on compn of expl

e = base of natural logarithms (2.718)

E = energy of activation of expl, in cal/mole

R = gas constant (1.986 cal/mole °K)

T = temp of flash in °K

The natural logarithm of above expression gives:

$$\ln \tau = \ln C + E/RT$$

which shows there is a straight line relationship betw $\ln \tau$ and $1/T$. This straight-line relationship was confirmed experimentally for most expls. Tangent of angle of straight line is equal to E/R and if T is known (as detd experimentally), E can be calcd. [Compare with Ref 39a under Detonation (and Explosion) Initiation, etc]

Table A
Temperature to Ignition in 5 Seconds (Unless Otherwise Stated)

| Explosive and Its Composition | USA | Remarks | Russia |
|--|-----------------|------------|---------|
| 80/20-Amatol (AN 80 & TNT 20) | 280 | decomp | — |
| 60/40-Amatol (AN 60 & TNT 40) | 270 | decomp | — |
| 50/50-Amatol (AN 50 & TNT 50) | 265 | decomp | — |
| Ammonal (AN 22, TNT 67 & Al 11) | 265 | decomp | — |
| Ammonium Nitrate | 465 | ignites | — |
| Ammonium Perchlorate | 435 | — | — |
| Ammonium Picrate | See Explosive D | — | — |
| Baratol [$Ba(NO_3)_2$ 67 & TNT 33] | 385 | ignites | — |
| BkPdr (KNO_3 74.0, S 10.5 & C 15.6) | 427 | ignites | 290-315 |
| Blasting Gelatin | — | — | 202-208 |
| Boronite A (AN 83, TNT 10 & B 7) | 288 | — | — |
| Boronite B (AN 75, TNT 20 & B 5) | 281 | — | — |
| Boronite C (AN 62, TNT 36 & B 2) | 268 | — | — |
| BTTN (1,2,4-Butanetriol Trinitrate) | 230 | decomp | — |
| CE (British) | See Tetryl | — | — |
| Cheddite | — | — | 258-265 |
| Comp A | 250 | decomp | — |
| Comp B | 278 | decomp | — |
| Comp C | 285 | decomp | — |
| Comp C-2 | 285 | decomp | — |
| Comp C-3 | 280 | decomp | — |
| Comp C-4 | 290 | decomp | — |
| Composition is given in Vol 3 pp C471, C479, C484 & C485, respectively | | | |
| Copper Chlorotetrazole | 305 | — | — |
| Cyanuric Triazide (No cap used) | 252 | in 0.1 sec | — |
| Cyclonite or Hexogen | See RDX | — | — |
| Cyclotetramethylenetetranitramine | See HMX | — | — |
| 70/30-Cyclotol (RDX 70 & TNT 30) | 265 | decomp | — |
| 65/35-Cyclotol (RDX 65 & TNT 35) | 270 | decomp | — |
| 60/40-Cyclotol (RDX 60 & TNT 40) | 280 | decomp | — |
| 30/70-Cyclotol (RDX 30 & TNT 70) | 290 | — | — |
| DADNPh (Diazodinitrophenol) | 195 | explodes | 180 |
| DBX (AN 21, RDX 21, TNT 40, Al 18) | 400 | ignites | — |
| DEGDN (Diethyleneglycoldinitrate) | 237 | — | 237 |
| DNPh (2,4-Dinitrophenol) | 315 | — | — |
| DNT (2,4-Dinitrotoluene) | 310 | decomp | — |
| DPEHN (Dipentaerythritol Hexanitrate) | 255 | explodes | 255 |
| Dunnite (Amm Picrate) | See Explosive D | — | — |
| EC Blank Fire [$NC(13.25\%)$ 80, $Ba(NO_3)_2$ 8, KNO_3 8, Starch 3, DPhA 0.75 & Aurine 0.25] | 200 | decomp | — |
| EDNA or Haleite | 189 | decomp | 190 |
| 55/45-Ednatol (EDNA 55, TNT 45) | 190 | decomp | — |
| EGDN (Ethyleneglycol Dinitrate) | See NGc | — | — |
| Explosive D (Amm Picrate) | 318 | decomp | 318 |

Table A-Cont'd
Temperature to Ignition in 5 Seconds (Unless Otherwise Stated)

| Explosive and Its Composition | USA | Remarks | Russia |
|---|---------|-----------|---------|
| Glycerol Dinitrate (GDN) | 257 | explodes | - |
| Glycerolmonolactate Trinitrate (GLTN) | 223 | - | - |
| Glycerol Trinitrate | | See NG | |
| Haleite (Ethylenedinitramine) | | See EDNA | |
| HMTPDA (Hexamethylenetriperoxidediamine) | - | - | <149 |
| HMX (beta) or Octogen | 327 | - | 335 |
| HNDPhA or Hexil | - | - | 325 |
| HNMnt (Hexanitromannitol) | 232 | 1 second | 205 |
| LDNR (Lead 2,4-Dinitroresorcinate) | 265 | explodes | 265 |
| LDNR, Basic (2,6-Dinitro-) | 295 | explodes | - |
| Lead Azide (LA) | 330-340 | explodes | 315-345 |
| Lead Styphnate (LSt) | 282 | explodes | 265-280 |
| Mannitol Hexanitrate | | See HNMnt | |
| Mélinite or Lyddite | | See P A | |
| Mercuric Fulminate (MF) | 210 | explodes | 175-210 |
| Metriol Trinitrate | 235 | ignites | - |
| Minol-2 (AN 40, TNT 40, Al 20) | 254 | ignites | - |
| NC (Nitrocellulose) (12.0% N) | - | - | 185-200 |
| NC (12.6% N) | 170 | decomp | - |
| NC (13.3% N) | - | - | 222 |
| NC (13.45% N) | 230 | - | - |
| NG (Nitroglycerin) | 222 | explodes | 200-222 |
| NGc (Nitroglycol) or EGDN | - | - | 237 |
| NGu (Nitroguanidine) | 275 | decomp | 270 |
| NIBTN (Nitroisobutylglycerol Trinitrate) | 185 | ignites | - |
| Nitropenta | | See PETN | |
| NSX (Nitrostarch Demolition Expl [NS (12.5% N) 49, Ba(NO ₃) ₂ 40, MNN 7, p-MNA 3 & oil 1]) | 195 | decomp | - |
| PA (Picric Acid) | 320 | decomp | 295-322 |
| Pentolite (PETN 50 & TNT 50) | 220 | decomp | - |
| Pentrite | | See PETN | |
| PETN (Pentaerythritol Tetranitrate (TEN in Rus) | 225 | decomp | 205-225 |
| Picratol (PA 52 & TNT 48) | 285 | decomp | - |
| PIPE (PETN 81 & Gulf Crown E Oil 19) | - | decomp | - |
| Plumbatol [Pb(NO ₃) ₂ 70 & TNT 30] | 238 | decomp | - |
| PLX (Nitromethane 95, ethylenediamine 5) | 430 | - | - |
| Potassium Dinitrobenzuroxan | 250 | - | - |
| PTX-7A (TNT 38.6, RDX 27.5 & Haleite 33.9) | 210 | - | - |
| PVA-4 (Polyvinylacetate 8, RDX 90 & DBuPh 2) | 375 | decomp | - |
| PVN (Polyvinyl Nitrate) | 265 | - | - |
| RDX (Cyclotrimethylenetrinitramine) | 260-270 | decomp | 230-260 |
| RIPE (RDX 85 & Gulf Crown E Oil 15) | - | decomp | - |
| SA (Silver Azide) | 290 | explodes | 310-320 |
| SF (Silver Fulminate) | - | - | 170 |
| Smokeless Propellants | - | - | 180-200 |
| TEN (Rus) | | See PETN | |

Table A -Cont'd
Temperature to Ignition in 5 Seconds (Unless Otherwise Stated)

| Explosive and Its Composition | USA | Remarks | Russia |
|-------------------------------------|-----------------------------|----------|-----------|
| Tetracene | 160 | explodes | 154 |
| Tetranitrocarbazole (TeNCbz) | 470 | decomp | - |
| Tetranitrooxanilide (TeNOx) | 392 | - | - |
| Tetryl (Brit CE) | 257 | ignites | 190-257 |
| 80/20-Tetrytol (Tetryl 80 & TNT 20) | 290 | ignites | - |
| 75/25-Tetrytol (Tetryl 75 & TNT 25) | 310 | ignites | - |
| 70/30-Tetrytol (Tetryl 70 & TNT 30) | 320 | ignites | - |
| 65/35-Tetrytol (Tetryl 65 & TNT 35) | 325 | ignites | - |
| Torpex (RDX 42, TNT 40 & Al 18) | 260 | decomp | - |
| Triazidotrinetrobenzene (TATNB) | 150 | 10 secs | - |
| Triethyleneglycol Dinitrate (TEGDN) | 223 | - | - |
| Trimonite (PA 90 & MNN 10) | 315 | decomp | - |
| Trinitroanisole (TNAns) | - | - | 290-296 |
| Trinitrobenzene (TNB) | - | - | 550 |
| Trinitrocresol (TNCrs) | - | - | 270-276 |
| Trinitrotoluene (TNT) | 475 | decomp | 310 & 475 |
| Trinitrotriazidobenzene | See Triazidotrinetrobenzene | | |
| Trinitroxylene (TNX) | - | - | 315-330 |
| Tritonal (TNT 80 & Al 20) | 470 | decomp | - |

Table B, taken from Ref 24, p 26, gives the lowest temps of ignition (or deflagration) and the time required for this (ignition period) when testing 0.05 g samples of HE's

Table B

| Explosive | Ignition Temp, °C | Induction period, secs |
|-------------------------|-------------------|------------------------|
| TNT | 275 | 423 |
| TNPhenol | 275 | 143 |
| TNXylene | 300 | 240 |
| TNResorcin | 245 | 31 |
| TNPhloroglucin | 200 | 18 |
| TNAniline | 87 | 85 |
| Tetryl | 180 | 40 |
| TNPhenyl-ethylnitramine | 160 | 25 |

A.F. Belyaev (quoted from Ref 24, p 26) has shown that conditions of ignition and of its temp depend to a great extent on the rate of expl reaction and on the volatility. It is difficult, or even impossible, to determine ignition point for very volatile expls if the samples are very small (such as 0.05 g). This is because the samples evaporate before the ignition temp is reached. The temp can be detd, however, if the sample size is increased. For example, ignition of a 0.05 g sample of TNA did not take place even at 600°, since the sample evaporated, but when the amt was increased to 0.1 g, the temp was 500° and $\tau=2.8$ sec.

F. Bowden & A. Yoffe, as described in Ref 24, pp 29-30, used for detn of expln temp the method of rapid adiabatic compression of air above the expl sample. The lowest pressure

at which expln takes place serves for the calcn of expln (or ignition) temp in °K using the following equation:

$$T_1 = T_0 \left(\frac{v_0}{v_1} \right)^{\gamma-1}$$

where: T_1 = expln temp
 T_0 = starting temp
 v_0 = vol of air over the sample before it is compressed
 v_1 = vol of air after compression
 γ = adiabatic exponent (pokazatel' adiabaty in Rus)

Table C gives expln temps in °C for induction period of 5 secs

Table C

| Explosive | °C | Explosive | °C |
|-------------|---------|-------------------|---------|
| MF | 175-180 | Tetryl | 190-200 |
| LA | 315-330 | RDX | 225-235 |
| AgA | 310-320 | PETN | 210-220 |
| L Styphnate | 270-280 | TNX | 315-330 |
| NC (12% N) | 185-195 | Amatol | 220 |
| | | Smokeless Powders | 180-200 |
| NG | 200-205 | Bk Pdr | 290-310 |
| TNT | 300-310 | PA | 295-310 |

Refs: 1) H. Weber, BullUSBurStandards **9**, 119 (1913) [The procedure originated by Weber and modified at PicArns is essentially the same as described in Ref 26, p XVI under Ignition (and Explosion) Temperature] 2) Marshall **2** (1917), 435-37 3) Barnett (1919), 213 4) A. Langhans, SS **15**, 161-63 (1920) & CA **14**, 3530 (1920) [Instead of using a bath of molten materials, such as Wood's metal, which may be scattered by the expln, Langhans proposed to use a metallic block (Pb or Fe) provided with cavities in which the test tubes (10 x 30 mm) contg the samples are inserted. An addnl cavity was provided for a thermometer or thermo-couple. The block was placed on a hot plate heated either by flame or electrically at the desired rate until the sample exploded, ignited or flashed] 5) M.M. Kostevitch, **23**, 156 (1928) [An apparatus consisting of a large diam test tube closed with a two-hole stopper: thru one hole passes a thermometer and thru the other the stem of a glass bulb (ampoule) contg a liquid sample. The test tube is inserted into a larger one in a manner such as

to have an air space between the walls and the bottom. The ensemble is suspended in a transparent high bp liquid placed in a large Pyrex beaker, provided with a hand stirrer and a thermometer. The beaker is heated on a hot plate until ignition or expln of sample takes place: Since the liq in the bath is transparent, the method allows one to observe the behavior of the sample during heating, such as a change in color, volatility, etc. It seems that this app has been used in Russia, because it is described in Rus text books such as that of Baum et al (1959), p 29, listed here as Ref 24] 6) Vennin, Burlot & Lécorché (1932), 211 7) Stettbacher (1933), 373 8) L.V. Clark, IEC **25**, 668 & 1389 (1933) 9) E. Berl & G. Rueff, Cellulosechemi **14**, 43-4 (1933) & CA **27**, 3328 (1933) (Apparatus for detn of expln temps especially of NC & smokeless propnts) 10) R. Wallbaum-Wittenberg, SS **34**, 199 (1934) (Ignition temp test) 11) Pepin Lehalleur (1935), 68 12) H. Henkin, "Determination of Explosion Temperature", OSRD **1986** (1943) 13) Davis (1943), 21 (Detn of ignition temp); 206 (Relation betw ignition temp and bp, as detd in 1940 by Belyaev & Yuzefovich: NG bp ca 245° vs ignition temp 200°; NGe 197° vs 195-200°; TNT 300° vs 295-300°; PA 325° vs 300-310°; and PETN 200° vs 215°) 14) Vivas, Feigenspan & Ladreda, Vol 4 (1944), 251 (Aparato para la prueba de explosión de las nitrocelulosas) 15) Pérez Ara (1945), 72-3 (Temperatura de inflamación o de decipitación) 16) Caprio, Vol 1 (1948) & Vol 2 (1949) - not found 17) PATR **1401**, Rev 1 (1950) 18) Belgrano (1952), 52-3 (Temperatura di accensione was detd by placing a small sample into an indentation of the iron plate, 80 x 150 mm by 15 mm thick, attached above a Bunsen burner. Two thermometers were inserted in cavities drilled thru the plate. Heating was conducted at the rate of 10-15° per min until the expl ignited or exploded. The other app used by Belgrano consisted of a molten paraffin bath in which a lower part of a small test tube contg a 0.1 g sample was plunged) 18a) Stettbacher (1952), 151 (Temperatura de deflagración) 19) P. Tavernier, MP **37**, 225-68 (1955); Engl transln by TechInfo & Library Services, Ministry of Supply, England, Feb 1959

(TIL/T.4837) & CA 51, 1609 (1957) (Expln temps of smokeless proplnts) 20) TM 9-1910 (1955), 36 (Ignition temp, definition); 50-2 (App for detn of explosion temp) 21) Dunkle's Syllabus (1957-1958), 137-48 (Thermal decompn in solids) 22) PATR 1740, Rev 1 (1958) (Expln temp test) 23) Cook (1958), 39 & 41 (Brief descriptions of explosion temperature tests) 24) Baum, Stanyukovich & Shekhter (1959), 24-28 [Temperatura vspyshki (flash temp) and "periód zaderghki" (period of delay) relationships]; 28-29 (Description of closed bath apparatus and of app designed by Kostevitch, Figs 3 & 4); 29-30 (Method of Bowden & Yoffe) 25) Andreev & Belyaev (1960), 325-28 (Detn of expln temp by the methods similar to those described in Ref 24, p 28-30) 26) PATR 2700, Vol 1 (1960), p XVI [Ignition (or Explosion) Temperature Test] 27) Dunkle's Syllabus (1960-1961), pp 12a-d (Thermal decompn in solids) 28) Military Standard MIL-STD-650, 3 Aug 1962, Method 506.1 (Explosion temperature test), USGovtPtgOff, Washington, DC (1962) 29) Anon, "Military Explosives", TM 9-1300-214/TO 11A-1.34 (1967), pp 5-7 & 5-8, Fig 5-6 (Explosion temperature test)

Section 9B

Detonation (and Explosion), Temperature Developed On. It may be defined as the maximum temperatures developed on detonation and explosion and must not be confused with Detonation (and Explosion) Temperature described in previous item

A. Calculation of Temperature of Detonation (or Explosion). The oldest and simplest method is based on the assumption that expln is an adiabatic process taking place at constant volume and that the heat evolved (Q_v), is used exclusively for heating the products of expln. Another assumption is that temp can be calcd by dividing the heat of expln by specific heats of the products of expln:

$$t = Q_v / \bar{C}_v$$

where \bar{C}_v = mean specific heat of products of expln in the interval betw 0°C and $t^\circ\text{C}$ and as it changes with the temp, it can be calcd from the equation:

$$\bar{C}_v = a + bt + ct^2$$

As the 3rd member of equation is small, it can be, for practical purposes, disregarded and the equation written as:

$$\bar{C}_v = a + bt,$$

where a = molecular heat of gas at 0°C and b = increment of mean molecular heat of the gas at 1°C

As Q_v is equal to $\bar{C}_v t$, it is also equal to $(a + bt)t$ or $at + bt^2$ and $bt^2 + at - Q_v = 0$

$$\text{This gives } t = \frac{-a + \sqrt{a^2 + 4bQ_v}}{2b},$$

which equation serves for calcn of temp of expln. It was employed by us to calculate the temp of expln of Coal Mining Explosives, Permissible (See Ref 51, pp C447-L to C449-R and Ref 3)

Bandurin & Rukin (Ref 45, pp 12-19) employed the above equation for calcn of temp of detop of HE's. Previous to this, however, they calcd \bar{C}_v 's for gases of expln and for carbon (which goes in smoke) by formulas of Kast. After this the preliminary temp which we designate as t_1 can be calcd as shown in the following example:

Example for TNT. Let us assume that TNT decomposes on expln according to the following equation:

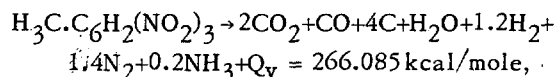

and then let us calc \bar{C}_v 's using equations of Kast:

$$\text{for CO}_2, \bar{C}_v = 2(9.0 + 0.00058t) = 18 + 0.00116t;$$

for CO and other diatomic gases

$$\bar{C}_v = 3.6(4.8 + 0.00045t) = 17.28 + 0.00162t;$$

for carbon, $\bar{C}_v = 4 \times 6 = 24$;

for H_2O , $\bar{C}_v = 4(4 + 0.00215t) = 16 + 0.0086t$;

for NH_3 , $\bar{C}_v = 0.2(10 + 0.00045t) = 2 + 0.00009t$

This gives specific heat for all the products of expln:

$$\bar{C}_v = a + bt = 65.28 + 0.00502t,$$

and the preliminary temp t_1 can be calcd as follows:

$$t_1 = \frac{-65.28 + \sqrt{(65.28)^2 + 4.0 \times 0.00502 \times 266.085 \times 1000}}{2 \times 0.00502} = \frac{-65.28 + \sqrt{9604.46}}{0.01004} = \frac{-65.28 + 98}{0.01004} = \frac{32.72}{0.01004} = 3259^\circ\text{C}$$

This gives absolute temp $T_1 = 3259 + 273 = 3532^\circ\text{K}$

Dunkle's Remark: The above reaction for TNT is not far from what was figured by him in the APL Report, "Energy Relationships in the RDX-TNT Systems", CGD/M-10, July 22, 1964, p5:

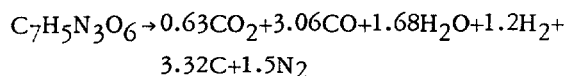

This is not the true detonation reaction, but corresponds to the overall reaction including interaction among the detonation products during cooling of the bomb, and gives heat and gas evolutions fairly close to those found in many determinations

A simpler method of Nernst & Wohl, also described in Ref 45, p 15, may serve as a check. In this method, it is required to make a preliminary assumption of temp of expln, so that C_v 's could be obtd for that temp from tables (See also Table 7, p 43 and Table 8, p 44 of Ref 7)

If the temp of 3600°K is assumed, then \bar{C}_v 's will be:

for CO_2 , $2 \times 11.7 = 23.4$; for CO , $1 \times 6.4 = 6.4$;
for H_2O , $1 \times 9.2 = 9.2$; for H_2 , $1.2 \times 5.9 = 7.08$;
for N_2 , $1.4 \times 6.3 = 8.82$; for NH_3 , $0.2 \times 11.7 = 2.34$
and for C , $4 \times 6 = 24$. This gives $\Sigma C_v = 81.24$ cal and temp can be calcd from the equation:

$$t_2 = Q_v / \Sigma \bar{C}_v = 266085 / 81.24 = 3266^\circ\text{C} \text{ and } T_2 = 3266 + 273 = 3539^\circ\text{K}$$

This temp T_2 appr agrees with temp T_1 and is close to the assumed temp of 3600°K

$$\text{The average } T = (T_1 + T_2) / 2 = (3552 + 3539) / 2 = 3545^\circ\text{K}$$

Using the same methods, Bandurin & Rukin obtd values for T 's which are given in Table A

Note: The temp for NG was detd by Beyling & Drekopf (Ref 7, p 45)

The 3rd method described by Bandurin & Rukin (Ref 45, pp 13-14) is based on the assumption that at constant volume all the energy evolved at the moment of expln is contained in the pro-

Table A

| Explosive | Method of | |
|-------------|-----------|---------------|
| | Kast | Nernst & Wohl |
| Amm Picrate | 2001 | 1940 |
| Tetryl | 3901 | 4070 |
| MF | 4766.3 | - |
| Ammonal | 3739 | - |
| NC (12% N) | 3500 | - |
| HNMnt | 4780 | - |
| PETN + 8 Al | 7659 | - |
| BkPdr | 3178 | - |
| RDX | 4060 | - |
| NG | - | 4320 |

ducts of expln and is equal to the increase of their internal energy. The method is based on the solution of the equation:

$$Q_v = \sum_i n_i (E_i T - E_i T_1) = \sum_i n_i \Delta E_i$$

where: Q_v = heat of expln interpolated to T_1 ($25^\circ\text{C} = 298^\circ\text{K}$); $E_i T$ = internal energy of 1 mole of i th component of products of expln at temp of expln T ; $E_i T_1$ = internal energy of the same component referred to T_1 ; n_i = number of moles of i th component of products of expln at temp of expln T ; $\Delta E_i = E_i T - E_i T_1$ or the change in internal energy of the i th products
Note: Accdg to Dunkle (Ref 52), calcn described in his Syllabus (Ref 40, p 253) is similar to the above method

Bandurin & Rukin (Ref 45, pp 14-19) gave some T values as calculated by different method

Cook (Ref 42, p 307-10, Tables 12.18, 12.18a and pp 315-16, Tables 12.20 & 12.21) lists calcd temps of expln, designated as T_3 , for a number of expls. Our Table B combines Cook's tables and arranges expls alphabetically. The method of calcg temperature of detonation T_2 used by Cook is described in his Appendix II, p 380, equation ii.13

Table B

| Explosive & Its Composition | Loading Density, g/cc | Temp of Explosion T_3 ($^{\circ}\text{K} \times 10^{-3}$) |
|--|-----------------------|---|
| 80/20-Amatol (AN 80 & TNT 20) | 1.0 | 3.06 |
| 50/50-Amatol (AN 50 & TNT 50) | 0.82 | 2.87 |
| 40% Ammonia Gelatin | 1.40 | 3.04 |
| 75% Ammonia Gelatin | 1.35 | 3.30 |
| 81.6/18.4/0-AN/Al/H ₂ O | 1.2 | 3.50 |
| 60/40/0-AN/Al/H ₂ O | 0.6 | 3.50 |
| 40/40/20-AN/Al/H ₂ O | 1.46 | 3.50 |
| 85/15-AN/DNT | 1.0 | 3.10 |
| 94.5/5.5-AN/Fuel Oil | 1.0 | 2.61 |
| 50/50-AN/TNT | 1.0 | 3.05 |
| 40/40/20-AN/TNT/H ₂ O | 1.41 | 2.25 |
| 76.5/23.5-AN/TNT | 1.0 | 3.00 |
| 65/20/15-AN/TNT/H ₂ O | 1.4 | 2.45 |
| 87.5/12.5-AN/Woodpulp | 1.0 | 2.58 |
| Dynamite (Extra or AN) | 0.8-1.2 | 2.87 |
| Dynamite (60%, Straight) | 1.32 | 3.69 |
| Dynamite (40%, Straight) | 1.4 | 3.30 |
| Gelatin (100%, Straight) | 1.5 | 4.65 |
| Gelatin (75%, Straight) | 1.35 | 3.87 |
| Gelatin (40%, Straight) | 1.5 | 3.10 |
| 80/20-LOX [Liquid O ₂ 80 & Activated Charcoal (of density 0.34) 20] | 1.7 | 5.8 |
| 73/27-LOX (Liq O ₂ 73 & charcoal 27) | 1.26 | ~6.6 |
| 70/30-LOX (Liq O ₂ 70 & charcoal 30) | 1.13 | ~6.6 |
| 60/40-LOX (Liq O ₂ 60 & charcoal 40) | 0.85 | 5.3 |
| 50/50-LOX (Liq O ₂ 50 & charcoal 50) | 0.68 | 3.5 |
| Nitroglycerin (NG) | 1.6 | 4.78 |
| Nitrostarch Powder No 1 (NS 25, AN-SN dope 73.5 & Al 1.5) | 1.2 | 3.00 |
| Nitrostarch Powder No 2 (NS 27.5, AN-SN dope 69.5 & Al 3) | 1.2 | 3.25 |
| PETN | 1.6 | 4.54 & 4.77 |
| RDX | 1.0 | 4.37 |
| RDX | 1.6 | 4.50 & 4.53 |
| Semigelatin (Compn not given) | 1.2 | 3.04 |
| Tetryl | 1.4 | 3.80 |
| Tetryl | 1.6 | 3.65 |
| TNT | 1.0 | 3.00 |
| TNT | 1.59 | 3.45 |
| 73/27-TNT/H ₂ O | 1.4 | 2.20 |

Note: These temperatures, T_3 , differ slightly from C-J Temperatures, T_2 , listed in Table under "Detonation, Chapman-Jouguet Parameters or Chapman-Jouguet Variables" Dunkle (Ref 40, pp 359-63) describes

method of calculating both explosion and detonation temperatures and in table on p 176 (See our Table C) he lists temperatures of detonation vs densities for several common HE's

Table C

| Explosive | Density, Δ , g/cc | Temp, T (°K) | Source of Information |
|-----------|--------------------------|--------------|-----------------------|
| Tetryl | 0.95 | 4800 | USBurMines |
| " | 1.5 | 5750 | " |
| " | 1.0 | 4030 | Schmidt |
| " | 1.61 | 4230 | " |
| TNT | 1.5 | 4417 | USBurMines |
| " | 1.0 | 3350 | Schmidt |
| " | 1.59 | 4130 | " |
| NG | 1.60 | 4670 | Roth |
| PETN | 1.0 | 5783 | USBurMines |
| " | 1.48 | 6900 | " |
| " | ? | 5000 | Schmidt |
| " | 1.50 | 5340 | Paterson |
| RDX | ? | 4810 | Roth |
| PA | 1.03 | 3600 | Schmidt |
| " | 1.63 | 4050 | " |

Methods of calculating temperatures of explosion of mining explosives are described in detail in Vol 3 of Encycl (Ref 51)

Accdg to von Stein & Alster (Ref 41), accurate determination of isochoric adiabatic flame temp of an expl often involves a series of tedious calcs of the equilibrium of compn of the expln products at several temps. Calcg the expln product compn at equilibrium is a tedious process for it requires the soln of a number of non-linear simultaneous equations by a laborious iterative procedure. Damkoehler & Edse (Ref 11) developed a graphical procedure and Winternitz (Ref 26a) improved it by transforming it into its algebraic equivalent. Unfortunately both methods proved less useful with heterogeneous equilibria which contain solid carbon

A more general treatment that applies readily to homogeneous and heterogeneous equilibria alike was developed by von Stein (Ref 11a). It was originally formulated to facilitate computations by desk computer of isobaric multicomponent flame product compns, but has been adapted at PicArns to the calcn by electrical analog computer of isochoric expln products

A second, less cumbersome, phase in the detn of temp of expln involves the calcn of both the isochoric heat of expln, $H_e^V(H_2O \text{ gas})$ of the explosive and the internal energies of the expln products at temp T relative to ambient temp θ . It is shown in this rept that the

selection of a new reference level for the internal energies enables one to determine T_e (temp of expln) directly from the isochoric heat of combstn, $H_c^V(H_2O \text{ gas})$, thereby circumventing an often iterative calcn of H_e^V from H_c^V

The description of the method given in Ref 40 is rather long and cannot be included here. The reader is referred to the original work

Following are some temps of expln calcd by this method: HMX (Cyclotetramethylenetetranitramine) 3880°K, Me thyltetryl 3052, Ethyl Nitrate 2572, Diazodinitrophenol 3087 and 1,1-Dinitropropane 2543°K

Note: In the report (as well as in many other papers and reports) these temps are called "explosion temperatures". As this term can be confused with temp to which an expl must be heated to induce expln, we prefer "temperature of explosion" when it concerns "temperature developed on explosion"

B. Experimental Determination of Temperature of Detonation (or Explosion). Accdg to Andreev & Belyaev (Ref 47, p 429), the first attempts to det temp of expls & proplnts were made in England at the end of the 19th century by Sir Noble and then later in France by H. Muraour. Noble at first tried to measure the temp by means of a thermocouple, but this was not successful. Then he exploded chges of compressed NC together with osmium wire in a manometric bomb. This melted the wire (mp of Os = 2500°C) and evaporated it depositing a layer of metal inside the bomb. Noble assumed that the temp of expln of NC is higher than 3200°C. In France temp of expln of mining expls was calcd from 1888 by the method of Mallard & LeChatelier (See Ref 1, p 17 and Ref 51, p C446-L) and it was considered satisfactory until Muraour tried to verify calcd values with experimental values. He exploded in manometric bomb AN/TNT mixts together with a thin Pt wire (mp 1750°). He found that minimum quantity of TNT in such mixts to cause partial melting of Pt wire was 7% and this gave expln temp equal to 1750°C. Then he calcd temp for such mixt and came to the conclusion that sp heat values given by Mallard & LeChatelier are generally too high. This was confirmed later by other investigators

Many other attempts were made in this century, especially before and during WWII,

such as by spectrographic method (Ref 4), by the method of Malpica (Ref 8), methods described in Ref 8a, etc and optical pyrometer method mentioned in Ref 14, p 71

Most of the attempts were unsuccessful mainly due to the following conditions:

a) The shortness of time, on the order of microseconds: b) The extremely high pressures, up to more than 200,000 atm; and c) The extremely high temperatures, on the order of 3000-6000°K or even higher (Ref 40, p 4). Much more successful were determinations of temps of deflagration (or burning) of propolnts, since the flame temps are lower, such as on the order of 2000-3500°K (See Ref 50, pp C34 & C35, Tables)

It might be considered that the first really successful method was developed by J.G. Fox (Ref 13). He obtd spectra of luminosity by means of a rotating drum camera with fixed grating and optical input system. He also obtd the spectrum of a comparison radiator at a known temp, and plotted the logarithm of the ratio of the intensities of two spectra against wave number. Temp was detd from the slope of the line. Color of the expl had a marked effect on the results, thus RDX gave 4090°K but when dyed blue 5200°K. Also end-on shots with NG gave higher readings than those taken sideways (quoted from Ref 43, p 306)

Cotter & Jacobs (Ref 18) improved the method by using velocity synchronization procedure to stop the moving front and gain a large increase in effective aperture. Boyer (Refs 25 & 42a) used four sensitive phototubes to pick up the radiation with a filter in front of each one isolating a region of the spectrum. The output of each tube was fed thru an amplifier to the vertical plates of an oscilloscope. The four oscilloscope screens were then photographed simultaneously, and the temp detd from the ratio of intensities assuming gray body radiation. The time of radiation was obtd by photographing the sweep trace (quoted from Ref 43, p 306)

Mason & Gibson (Ref 26) applied Boyer's four-color optical method in their basic study of the fundamental parameters of the detonating process. A number of progress repts was issued, but no final rept. As results of this important work were not published in the literature and

as the repts are not easily available, the work is described here in detail. Following are the reports:

a) Progress Rept Jan-March, 1948. Preliminary values were detd for PETN powders using a phototube oscilloscope network, with which a time-record of the radiation from the detonated chge was obtd. The pdr of av particle diam 30 microns was packed in plastic tubes of ID 1.93 cm. Av temp at density 0.60 was 4160°K, 4185° at d 0.80 and 3750° at d 1.54

b) Progress Rept April-June, 1948. Measurements of temp of deton of PETN were made by means of a radiation method. Results have been obtd showing two peaks of luminosity in the radiation intensity; the initial peak was due to the deton wave while the second peak was associated with the shock wave and secondary phenomena. The data with greatest time resolution on the cathode ray tube sweep indicated that temp of deton decreased with increase of loading density, and this agreed with theoretical evaluation by Brinkley & Wilson. These results also indicated that the temp of deton wave was only slightly higher than that of the shock wave. The investigation of temp of deton has been continued with the use of four-channel oscilloscope and filter-phototube network to measure the radiation intensities at four different wavelengths for each test chge. Final values of temp of deton could be detd with this equipment for the entire range of loading densities of various expls

Table D gives selected values for PETN chges ca 2 cm diam and 20 cm long detonated in air.

Table D

| Density g/cc | °K of detonation wave | °K of shock wave |
|-----------------|--------------------------|---------------------|
| 0.85 | 4290 | 4100 |
| 1.00 | 4010 | 3632 |
| 1.55 | 3680 | 3560 |

c) Progress Rept July-Sept, 1948. Initial detn of temp of deton of PETN pdr was made using the four-channel oscilloscope coupled with network of four optical filters, multiplier phototubes, and amplifiers. A luminosity-time record of the radiation emitted at each of four wavelengths during the deton interval was obtd by photographing on a single negative the horizontal sweep traces of the four cathode ray

tubes triggered simultaneously by a signal wire in the test expl. Two values of radiation intensity were detd from these four luminosity records and, consequently, two independent temp measurements were estimated for the deton of each test charge

Table E taken from Progr Rept July-Sept 1948 gives calculated temps of detonation of PETN at various densities

Table E

| Density of Charge g/cc | Average °K |
|---------------------------|---------------|
| 0.70 | 3580 |
| 0.75 | 3670 |
| 1.50 | 5910 |
| 1.60 | 6040 |

d) Progress Rept Oct-Dec, 1948. The work on detm of temp of deton was continued and the values listed in Table F were obtd for PETN detonated in air at atm pressure

Table F

| Density of Charge g/cc | Average °K |
|---------------------------|---------------|
| 0.68 | 3750 |
| 0.95 | 4020 |
| 1.55 | 6460 |
| 1.68 | 5840 |

In Table G are listed temps for PETN charges detonated in glass cylinders

Table G

| Density of charge g/cc | Average °K |
|---------------------------|---------------|
| 0.70 | 4980 |
| 0.95 | 4960 |
| 1.60 | 5520 |

In Table H are listed temps for PETN charges detonated within water-filled glass cylinders

Table H

| Density of charge g/cc | Average °K |
|---------------------------|---------------|
| 0.60 | 4080 |
| 0.95 | 3970 |
| 1.55 | 5650 |

e) Progress Rept Jan-March, 1949. Temps of deton by radiation method of PETN charges contained within evacuated glass cylinders are shown in Table I

Table I

| Density of charge g/cc | Average °K |
|---------------------------|---------------|
| 0.82 | 5590 |
| 1.55 | 5230 |
| 1.60 | 5330 |

Temps of detonation by radiation method of PETN charges contained in water-filled glass tubes are given in Table J

Table J

| Density of charge g/cc | Average °K |
|---------------------------|---------------|
| 0.72 | 4020 |
| 0.98 | 3990 |
| 1.44 | 5350 |

f) Progress Rept April-June, 1949. Temps of deton by radiation method for Tetryl powders in air at atm pressure are given in Table K

Table K

| Av particle diam, microns | Density, g/cc | Average °K |
|------------------------------|------------------|---------------|
| 10 | 0.70 | 4120 |
| 10 | 1.60 | 6050 |
| 800 (20-mesh) | 0.95 | 4460 |
| 800 (20-mesh) | 1.62 | 6200 |

Table L gives temps for TNT powders detonated in the same manner as Tetryl

Table L

| Av particle diam, microns | Density, g/cc | Average °K |
|------------------------------|------------------|---------------|
| 5 | 0.75 | 4610 |
| 5 | 1.55 | 4960 |
| 800 (20-mesh) | 1.54 | 5320 |

g) Progress Rept July-Sept, 1949. The work on temp detn from light emission was delayed pending the development of phototube-amplifier networks with higher frequency response

h) Progress Rept, Oct-Dec, 1949. Work on instrumentation necessary for the accurate recording of temp in the deton zone was continued. The four-channel oscilloscope was improved

to permit operation at an accelerating potential of 17.5 kilovolts; large vertical deflections of single transients could then be recorded for sweep durations as short as 7 microsecs. PETN & Tetryl chges of 2.0 cm diam and high loading density were used in evaluating the method. Luminosity-time curves for Tetryl chges recorded by the oscilloscope using the high-frequency response phototube-amplifier networks indicated deton peak widths (at half-maximum intensity) of less than 1 microsec for a radiation slit-aperture width of 1 mm. This peak width was approx equal to that previously observed for PETN. These tests indicated the extremely short reaction zones for these expls

i) Progress Rept, Jan-March 1950. Using an improved app for measuring spectral intensity distribution of the light emitted from deton waves, the temp of 5450°K was detd for un-sheathed PETN powder, d 1.60 g/cc in air and at atm pressure. Radiation slit width 1.5 mm

j) Progress Rept, April-June 1950. Using the same techniques as in previous report but with slit of 1 mm, the values shown in Table M were obtd for un-sheathed expls in air

Table M

| Explosive | Loading Density | Average °K |
|-----------|-----------------|------------|
| PETN | 1.18 | 6000 |
| PETN | 1.64 | 5750 |
| Tetryl | 1.30 | 6000 |
| Tetryl | 1.60 | 4900 |
| TNT | 1.29 | 4850 |
| TNT | 1.56 | 5500 |

k) Progress Rept, July-Sept 1950. Radiation temps observed without slit aperture gave the values listed in Table N for interval after detonation of 18 microseconds

Table N

| Explosive | Loading Density | Average °K |
|-----------|-----------------|------------|
| PETN | 1.64 | 6220 |
| Tetryl | 1.64 | 5335 |
| TNT | 1.56 | 4840 |

l) Progress Rept, Oct-Dec 1950. Temps of deton in air at atm pressures for un-sheathed chges. Radiation slit width 1 mm: PETN 5500°K at d 1.5; Comp C-3 (plastic) 5900; Comp C-4 (plastic) 6050; Tetryl 5180 at d

1.64 and TNT 4280 at d 1.53

Gibson & Mason (Ref 36) continued at the Bur of Mines the work on determination of temps of deton which was described in Ref 26. The results are outlined below:

a) Progress Rept No 1, July-Sept 1953. An apparatus for detn of temp of deton which employs the radiation from an embedded plastic rod placed axially in the chge at the trailing end was analyzed with an electro-optical system. The radiation fell on two photomultipliers each having a high-transmission multi-layer interference-type filter, and a spectral separation giving the optimum light ratio. The electrical signals thus provided were to be logarithmically attenuated and combined to provide a single electrical potential, which was proportional to the ratio of the input potentials, and displayed it, for recording, on a cathode-ray screen. More detailed description of the apparatus was given in the rept, but no new data on temps of deton were given

Application of *image converter camera* (See Vol 1 of Encycl, p C14) to *streak photography* (see Vol 1, p C17-L) was considered

b) Progress Rept No 2, Oct-Dec 1953 - was not at our disposal

c) Progress Rept No 3, Jan-March 1954. Work was continued on the improvement of radiation apparatus described briefly in Rept No 1, with emphasis on calibration. A series of tests was made on Pentolite and Tetryl chges but no values were reported. Additional operating characteristics of the image converter instrument were investigated to be later reported in the *RevSciInstrs* 25, 173-76 (1954)

d) Progress Rept No 4, April-June 1954. Description of difficulties in adjustment and operation of apparatus described in previous repts. Some improvements were required

e) Progress Rept No 5, July-Sept 1954. The apparatus was finally modified and adjusted in an attempt to improve reliability and the tentative values listed in Table O were obtained

Table O

| Explosive | Density g/cc | Temperature, °K | |
|-----------|--------------|-----------------|-------------|
| | | Air | Propane (x) |
| Tetryl | 1.64 | 4700 | 5000 |
| TNT | 1.44 | 5300 | 3900 |

(x) In this test, propane-impregnated chges were fired in ambient propane

e) Progress Rept No 6, Oct-Dec 1954. Resumption on temp work got underway late in the quarter, but results were not reported

f) Progress Rept No 7, Jan-March 1955. A series of tests on PETN & Tetryl at two loading densities and on TNT at a single density. The results were presented at the 2ndONRSympDeton (1955). Table P gives the average temperatures

Table P

| Explosive | Density, g/cc | T, °K |
|-----------|---------------|-------|
| Tetryl | 0.95 | 4800 |
| Tetryl | 1.5 | 5750 |
| PETN | 1.0 | 5783 |
| PETN | 1.48 | 6900 |
| TNT | 1.5 | 4417 |

There are also given curves of relationship betw temps of deton and densities for PETN, Tetryl & TNT, based on the values obt'd by P. Caldirola, JChemPhys 14, 738-40 (1946), as compared with the values obt'd at BurMines (See Fig 1 of the progr rept)

g) Progress Rept No 8, April-June 1955. Temps of deton of PETN, RDX, Tetryl & TNT were det'd by radiation method and plotted vs their corresponding loading densities. The relationship was nearly linear

The work was resumed at the BurMines by Mason, Gibson & Strasser on July 1955 (Ref 37) and results are outlined below:

1) Progress Report No 9, July-Sept 1955. Although the method of temp measurement in deton of solid expls was fairly accurate, the reproducibility needed improvement. A method for detn of temp of deton of NG is described and the values are tabulated. The grand mean is ca 4215°K

2) Progress Rept No 10, Oct-Dec 1955. A new contemplated modification of apparatus for detn of temp of deton, using the 21-foot grating spectrograph, was briefly described and its diagram is given. As the apparatus was not yet constructed, no determinations were made

3) Progress Rept No 11, Jan-March 1956. The apparatus using the 21-foot grating spectrograph and oscillographic recording stations was constructed and installed. A more detailed description was given and its photographic view is shown in Figs 3 & 4. No values for temps were reported

4) Progress Rept No 12, April-June 30, 1956. In this final quarterly progress rept period, it was hoped that comprehensive data could be accumulated and presented on the "probe method" of temp of deton determination for NG, Tetryl and PETN. However, delivery of Textronix oscilloscopes was slow and the condition of two of the four units made them unusable on arrival. As a result, the basic problem - that of spectral distribution of the radiation - could not be attacked with the new equipment. The tests were conducted, however, with an improved apparatus described in Progr Repts No 10 & 11 and the following mean results were obt'd: 4900°K for Tetryl and 4000°K for NG

Lebeau (Ref 27), Weber (Ref 28) and Henning (Ref 29) described various method of measuring temps of deton

Harris (Ref 33) reviewed the following methods described in the literature before 1953 and considered their applicability to the measurement of temp of deton:

a) *Thermocouples*. They are usually good up to about 1750°, however, the couples composed of pure tungsten (W) against 75/25-W/Mo can be used in inert gases up to 3000°C. The best available temp-stable materials (carbides, nitrides and borides) melt below 4000°C. This means that there is no material which will withstand the high temps of most explns if any attempt were made to have a measuring instrument imbedded in the expl itself before its initiation. Furthermore, no thermocouple could stand the shock waves; they are susceptible to a pressure effect and their response time is too slow in comparison with duration of deton, which is on the order of a few microseconds

b) *Resistance thermometers*, such as of Pt (up to 1100°C) and of 90/10-Pt/Rh coated with quartz (up to 1400°C), are subjected to the same limitations of time response as thermocouples

c) *Pyrometric cones*. They can be used to ca 2000°C, but cannot follow the fluctuation of temp as they would be destroyed by the shock wave

d) *Photography*. In view of the foregoing encounter with any kind of object inserted into the deton wave, photographic methods were introduced, such as estimation of temp by measurement of the density of blackening produced on a photographic plate, in particular an infra-red-sensitive material, by a given exposure

e) *X-Rays*, especially with use of electron multipliers, permit calcn of gas temps from gas density measurements.

f) *Pyrometers*, of which several types are known (such as the total radiation-, spectral radiation- and color pyrometers) measure the radiation energy from the source. The following varieties of color pyrometers were considered by Harris to be promising: "photomultiplier-", "image converter-", and "image opticon-" pyrometers

g) *Ionization of a gas* method is used to det electron pressures from ratios of the relative intensities of Ba I and Ba II lines from Ba added to carbon arcs with known excitation temps. High pressures decrease ionization and broaden spectral lines

h) *Electron temperature methods*, which are not clearly described by Harris, are applied to high-pressure arcs. The temp is detd from the continuous emission at the limits of spectral series, the broadening of excited atomic levels caused by near approach of electrons or ions, of the thermal radiation of the electrons in the microwave region. The electron temp decreases with rising pressure

i) *Band spectrum* methods can give temps from the band spectra and the relative intensities of the lines, but the high pressures of deton can spoil the band structures

j) *Line reversal* methods appear difficult to apply to expls

k) *Line profile* method is considered unsuitable for expls on acct of extremely high pressures

l) *Spectral distribution* method takes the radiation from the flame, arc or expln and analyzes it with a spectrograph, using either a photographic plate, a bolometer, a thermocouple, or a photocell. A Kerr cell or other type of shutter could be used to obtain multiple images of the spectrum of a detong expl (quoted from Ref 40, pp 4-5 and Ref 43, pp 305-06)

Hett & Gilstein (Ref 34) reviewed all the foregoing methods, as well as others, and discussed those which Harris (Ref 33) considered most promising:

a) *Photomultiplier color pyrometer*, responsive up to 10^{-8} sec

b) *Image converter pyrometer*, which converts electromagnetic radiation into photoelectrons that are accelerated and focused on a screen which is then photographed

c) *Image opticon spectrograph* which offers

increased light sensitivity, great spectral range of response and time resolution of higher order than a photographic plate (quoted from Ref 43, p 306)

Tyroler (Ref 39) of PicArns devised a portable and easily operated photographic app giving the brightness temp distribution from expln phenomena as a function of time. The app consists of a 35-mm high-speed "fastax" camera, combined with a device for recording only "monochromatic" light and a "calibrator" The function of the latter is to put stripes of various densities along the edge of the film, each stripe simulating a specific brightness temp. For a phenomenon of brightness temp above the range of the stripes, a "neutral filter", of known transmission, at the wavelength utilized, can be placed in front of the camera lens so that the densities registered by the phenomenon are within this range. This takes advantage of the approx linear relationship betw the logarithm of the brightness temp and the density of blackening produced on the film (quoted from Ref 43, p 305)

Gibson et al (Ref 41a) described a method which was devised at the BurMines, Pittsburgh for sampling the optical radiation from the interior of detong solid-expl chge by introducing a transparent plastic rod axially into the chge at the time of fabrication. The radiation was analyzed by a grating spectrograph, using four bands 100Å wide and 600Å apart. The radiation intensities were used to calc the color temps within the detong expl. The app was calibrated by a radio-frequency-excited lamp known to have gray-body radiation. The expl chges were vacuum-impregnated with propane to replace the air in the intergranular voids to eliminate light emission from the air shock

As mentioned above, this work was conducted at the BurMines and its description is scattered in various Progress Repts. Part of this work concerning Density-Temperature of Detonation Relationship is reported in this Volume under Density-Pressure of Detonation and Density-Temperature of Detonation Relationships, where the BurMines Progr Repts are listed as Refs 2 & 3

The theory of the method, as given on p 628 of Ref 41a, is based on the spectral distribution of the energy radiated from the detonation zone. Wien's law gives the energy radiated by

a black body of temperature T at any wavelength λ in a band of width $\Delta\lambda$, as

$$E_{\lambda} = c_1 \lambda^{-5} e^{-c_2/\lambda T} \Delta\lambda \quad (1)$$

Use of two channels, however, makes the measurement of absolute energies unnecessary. Only a ratio need be measured:

$$\ln \frac{E_1}{E_2} = -5 \ln \frac{\lambda_1}{\lambda_2} - \frac{c_2}{T} \left(\frac{1}{\lambda_1} - \frac{1}{\lambda_2} \right) - \ln \frac{\Delta\lambda_1}{\Delta\lambda_2} \quad (2)$$

Conversion to common logarithms gives

$$\log (E_1/E_2) = A + B(1/T) \quad (3)$$

where B is a constant which depends on the wavelengths used and can be found from the constants of the apparatus, while A is also constant and is determined from the ratio E_1/E_2 of a black or gray body at a known temperature

In practice, neither the absolute energies nor their ratio is determined directly. Instead, the radiation of a particular wavelength falls on a multiplier-type phototube, and the voltage developed across its load resistor is measured with a cathode-ray oscillograph. The deflection to the oscillograph is then proportional to E :

$$D = kE \quad (4)$$

substituting D/k for E in equation (3) gives

$$\log (D_1/D_2) = \log (k_1/k_2) + A + B(1/T) \quad (5)$$

Combining constants gives

$$\log (D_1/D_2) = A' + B(1/T) \quad (6)$$

Equation (6) is used to calibrate the apparatus and determine the detonation temperature

Baum et al (Ref 44, p 97) described the spectroscopy method developed in Russia in 1945 by Alentsev, Belyaev, Sobolev & Stepanov, which was applicable only to transparent liquid expls, such as NG, NGc, etc. In order to eliminate luminosity caused by shock wave in the atmosphere, the authors immersed the test tube with sample in water. For a more detailed description of the method, see Ref 16 and pp 98-100 of Ref 44. The values obt'd by this method are considerably lower than the calcd values. For example, for NG the exptl value was only 3150°K vs 4520°K obt'd by calcn and for NGc 3160 vs 4700

Voskoboinikov & Apin devised a "color-optical" method which is not very clearly de-

scribed in the Engl transl available to us listed under Ref 46. A better, although briefer, description is given by Andreev & Belyaev (Ref 47, pp 429-30). We give below a brief description based on both refs

The method of Voskoboinikov & Apin was devised for liquid transparent expls, but it can also be used for semitransparent solid expls, provided they are compressed to the crystal density. In case of liquids, the sample was placed in a cylindrical plexiglas cell with a transparent bottom and in case of a solid, the end of the cylindrical chge was immersed in water to cut out the high luminosity of the air shock wave arising from dispersion of the products from the end. Care was taken in the case of solid expl chges to have them free of cracks and of air bubbles adhering to their end surface. The luminosity produced on deton was registered by means of a FEU-29-M photomultiplier, the current being recorded on a single-sweep OK-17M oscillograph. In front of the photomultiplier was placed an object with an aperture, which permitted use of the luminosity of a limited section of the bottom of the charge opposite to the end initiated. The continuous spectrum of luminosity obt'd by this method could be separated into sections of desired wave lengths, two at a time (usually red and blue spectra), by means of two photofilters so that their intensities could be compared. The data obt'd were used to calculate deton-front temps using the equation listed on p 429 of Ref 47

The following Table Q gives temps of deton-front at certain densities together with deton velocity and pressure of expln values

Table Q

| Explosive | Density g/cc | Temp °K | Velocity m/sec | Pressure, atm |
|-----------|-----------------|------------|-------------------|------------------|
| DINA | 1.70 | 3700 | 8000 | — |
| MeN | 1.21 | 4500 | 6750 | — |
| NG | 1.60 | 4000 | 7650 | 250000 |
| NGc | 1.50 | 4400 | 7400 | — |
| NMe | 1.64 | 3100 | 6400 | 133000 |
| PETN | 1.77 | 4200 | 8500 | 340000 |
| RDX | 1.79 | 3700 | 8800 | 390000 |
| TeNMe | 1.14 | 3700 | 6300 | — |

Voskoboinikov & Sosnova (Ref 49) det'd, using the "color optical" method, described in Refs 46 & 47, temps of deton-front for liquid

mixts of TeNMe with C_6H_{14} , CH_3NO_2 , $C_6H_5NO_2$ & DNT; and of NG with CH_3NO_2 .

Also suspensions of C & TNT in TeNMe and of solid expls Ammonal & Pentolite. They also detd deton velocities for these expls using ionization method

Refs: 1) E. Sarrau, "Théorie des Explosifs", Gauthier-Villars, Paris (1895), 15-18 & 65 (Température théoretique des réactions explosifs) 2) Marshall 2(1917), 142 3) C.A. Taylor & W.H. Rinkenbach, "Explosives, Their Material, Constitution and Analysis", USBurMinesBull 219 (1923), 107-14 (The thermochemistry of expls) 4) I.O. Griffith, PrPhysSocLondon 38, 85-7 (1925) & CA 20, 863(1926) (Application of spectrophotography to the measurement of high temps) 5) Marshall 3(1932), 453 5a) Vennin, Burlot & Lécorché (1932), 36-50 (Calcul des températures d'explosion) 5b) Stettbacher (1933), 85-96 (Die Explosions-temperatur); 95, Table 9 (Expl props of some expls including temperature of detonation) 6) Pepin Lehalleur (1935), 43 (Formule de Mallard et Le Chatelier pour calculer la température d'explosion) 7) Beyling & Drekoop (1936), 41-8 (Die Explosionstemperatur) 8) G. Malpica, GenElecReview 1941, p 439 (Temperature measurement from ratio of energy emitted at two wavelengths) 8a) American Institute of Physics, "Temperature, Its Measurement and Control in Science and Industry", Reinhold, NY (1941) 9) F.W. Brown, "Theoretical Calculations for Explosives.

I. Explosion Temperatures and Gaseous Products and the Effects of Changes in Carbonaceous Material", USBurMinesTechPaper 632 (1941) 9a) J.O. Hirshfelder et al, "Thermochemistry and the Equation of State of the Propellant Gases", OSRD 547(1942)

10) S.R. Brinkley Jr & E.B. Wilson Jr, "Revised Method of Predicting the Detonation Velocities in Solid Explosives", OSRD 905 (1942) (Detd some temps of deton, among them Tetryl $3620^\circ K$ at d 1.0 & 3380° at d 1.6; for TNT $3170^\circ K$ at d 1.0) 11) G. Damköhler & R. Edse, ZElektrochem 49, 178(1943) (Determination of temp of deton by systematic graphical procedure, which in the case of homogeneous gas equilibria, reduced considerably the trial-error work) 11a) M.R. von Stein, ForschGebieteIngenieur 14, 113 (1943) (A general method that applied readily

to both homogeneous and heterogeneous equilibria in determination of temp of expln is described. This method is quoted in Ref 40) 12) Vivas, Feigenspan & Ladreda 4(1944), 26-9 (Cálculo de T de la explosión) 13) J.G. Fox, "Spectrographic Measurement of Detonation Temperature", NavOrdRept 200-45 (1945); PB Rept 36957 (1945) (Detn of spectrographic methods of temp developed on deton of military and other HE's) 14) Pérez Ara (1945), 42-8 (Cálculo de la temperatura de explosión); 70-2 (Determinación de la temperatura de explosión) 15) G. Herzberg & G.R. Walker, "Optical Investigations of Initiation and Detonation", Univ of Saskatchewan, Rept March 1945-August 1946, Project XR-84, NRC (Canada) and Nature 161, 647-48 (1948) 16) M.L. Alentsev & A.F. Belyaev, ZhEksp-TeorFiz 16, 990(1946) (Measurement of temp of deton in liquid expls) 17) P. Caldirola, JChemPhys 14, 738(1946) (Temps of deton for Tetryl $4400^\circ K$ at d 1.0, 4980° at d 1.45 and 5140° at d 1.61; for TNT 3210° at d 1.0, 3860° at d 1.46 and 4020° at d 1.59) 18) T.P. Cotter & S.J. Jacobs, "Studies Pertaining to the Measurement of Temperature in a Detonating Explosive", OSRD 5618(1946); S. J. Jacobs, Ibid, PhysRev 72, 176(1947) & CA 43, 4467 (1949) (Determination of temps in detonating zone by optical methods offered promise in extending the knowledge of the deton process) 19) D. Mitchell & S. Paterson, Nature 160, 438(1947) (Detn of temps of deton) 20) M.A. Cook, JChemPhys 15, 5181(1947) (Temp of deton of Tetryl $4200^\circ K$ at d 1.0 & 4700° at d 1.6 and of TNT 3700° at d 1.0 and 4170° at d 1.6) 21) Muraour (1947), 71-3 (Température d'explosion) 22) S. Paterson, Research 1, 221(1948) (Temps of Tetryl: $4140^\circ K$ at d 0.5, 4450° at d 1.0 & 4750° at d 1.5; and of TNT $3250^\circ K$ at d 0.5, 3870° at 1.0 & 3870° at 1.5) 23) Caprio 1(1948), 27-32 (Calcolo della temperatura di esplosione); 46-7 (Misura della temperatura) 24) Stettbacher (1948), 14-16 [Detonations- (Explosions-) Temperatur] 25) R.L. Boyer, PhysRev 74, 1221(1948) (An exptl method developed to determine temp developed on deton of HE's) 26) C.M. Mason & F.C. Gibson, "The Physics and Chemistry of Explosive Phenomena", USBurMinesProgressRepts from Jan 1, 1948 to Dec 31, 1950, Contract NA onr.29-48; Project

- NR 053 047 26a) P.F. Winternitz, p 623 in the 3rdSympCombstn (1949) (The method of Damkohler & Edse, Ref 11, quoted in Ref 40, was transformed into its algebraic equivalent, thus extending its utility when dealing with homogeneous equilibria 27) P. Lebeau (editeur), "Les Hautes Températures et Leur Utilization en Chimie", Masson, Paris (1950) 28) R.L. Weber, "Heat and Temperature Measurement", Prentice-Hall, NY (1950) 29) I.F. Henning, "Temperaturmessung", Barth, Leipzig (1951) 30) Stettbacher, Pólvoras (1952), 17-19 (Temperatura de detonación) 31) Belgrano (1952), 3-4 (Temperatura di esplosione) 32) Taylor (1952), 43 (Equation for the temp of expln); 59, Table 14 (Approximate relations of temps of expln to heats of expln) 33) F.S. Harris Jr, "The Measurement of Temperature in Explosives", Univ of Utah Tech Mem (Aug 31, 1953) (A literature survey giving a summary of methods of measuring temps developed on deton of expls) 34) J.H. Hett & J.B. Gilstein, "A Study of Techniques for the Measurement of Detonation Spectra and Temperatures", ResDiv of NYUniv, Final Rept May 14, 1953. Contract DA-30-069-ORD-945 35) J.B. Conway et al, JACS **77**, 2026-27 (1955) (The production of a flame temp of 5000°K) 36) F.C. Gibson & C.M. Mason, "Detonation and Explosives Phenomena", USBurMinesProgressRepts July 1, 1953 to June 30, 1955. OrdnProject TB2-0001, ArmyProj 599-01-004 37) C.M. Mason, F.C. Gibson & A. Strasser, "Research Program on Detonation and Explosives Phenomena", US-BurMinesRepts Nos 9 to 12 from July 1955 to June 30, 1956, OrdnCorpsProject TA3-5101, ArmyProject 504-01-015 38) H. Edels & D. Whittaker, PrRoySoc **240A**, 54-66 (1957) (Determination of arc temperatures from shock velocities) 39) J. Tyroler, "A Self-Calibrating High-Speed Photographic Pyrometer", 6thSympCombstn (1957), p 763-65 40) Dunkle's Syllabus (1957-1958), 176 (Temp of detonation vs density for several expls, taken from various sources); 244 (Resumé of PATR listed here as Ref 41); 253 (Equation for calcn of temp developed on detonation); 304-06 (Experimental determination of temperature of detonation); 384-86 (Attainment of extremely high temperatures) 41) M.R. vonStein & Jack Alster, "An Improved Calculation of the Explosion Temperature", PATR **2501** (1958); OrdnProject TA3-5101; Dept of the Army Proj 5A04-01-015 (A resumé of this rept is given in the text at the end of methods of calculation) 41a) F.C. Gibson et al, JApplPhys **29**, 628-32 (1958) (Determination of temperature of detonation, applying the light pipe, weakly luminous filler and electro-optical method) 42) Cook (1958), 37-8 & 63 (Measurements of temperatures of detonation); 307-10, Table 12.18 (Explosive properties of numerous explosives including their temperatures of detonation, designated as T_3 ; a slightly abbreviated version of the table is listed here in the text); 315, Table 12.20 [Temps T_3 & T_2 for LOX (Liquid Oxygen Explosives); 316, Table 12.21 (Temp T_3 for AN-TN-Water slurries) 42a) F.C. Gibson et al, JApplPhys **29**, 630-32 (1958) (Detonation temperatures by four-color pyrometer) 43) S.A. Hoenig, RevSciInstr **29**, 704-05 (1958) (Use of a constant current hot wire for measurement of extreme temperatures) 43a) W. Lochte-Holtgreven, "Progress in Physics", Vol XXI, pp 312-80 (Production and measurement of high temperatures) 44) Baum, Stanyukovich & Shekhter (1959), 96-100 (Temperatures of explosion of some liquid explosives determined by calculation and by the spectroscopic method of Alentsev & Belyaev. Attempts to use the exptl method on solid HE's was unsuccessful. Exptl values for liquid expls like NG or NGc were ca 1500°K below those obtained by calculation) 45) Bandurin & Rukin (1959), 12-19 (Methods of calcn of temps of expls) (See in the text) 46) I.M. Voskoboinikov & A.Ya. Apin, DoklAkadN **130**, 804-06 (1960); CA **56**, 619 (1962) & Explosivstoffe **1963**, 111. Engl transltn "The Measurement of Detonation-Front Temperatures for Explosives", issued as JPRS 5702 and distributed as OTIA 8500, OTS 60-41489 (See abstract in the text) 46a) Zel'dovich & Kompaneets (1960), pp 84-5 (Comparison of temperatures associated with an explosion and a detonation in gases) [Temperature of explosion, T' , in gases may be calcd from the expression $T' = Q/c_v$, where Q is heat evolved on explosion and c_v specific heat of the explosion products. Temperature of detonation, T, may be calcd from the expression: $T = 2kQ/(k+1)c_v$. On dividing the first expression by the second, we obtain:

$T^1/T = 2k/(k+1)$. This gives, on substitution, $k=9/7$ (for diatomic gases), temperature of detonation $T=8/9 T^1$] 47) Andreev & Belyaev (1960), 425-28 (Detn of temp of deton by calcn); 429-30 (Experimental methods for detn of temp of deton) (See in the text) 48) Dunkle's Syllabus (1960-1961), p 15a (Discussion on the paper of Lochte-Holtgreven, listed here as Ref 43a) and 25a-b (Detonation temperature) 49) I.M. Voskovoinikov & G.S. Sosnova, *ZhPriklMekh i TekhFiz* 1961, No 4, 133-35 & CA 56, 3712-13 (1962) (Temps of deton for some expls detd by calcn and by experiment) (See in the text) 50) PATR 2700, Vol 2 (1962), pp C34 & C35, Tables (Isochoric flame temps for various proplnts) 51) PATR 2700, Vol 3 (1966), pp C447-L to C449-R (Calcn of temp of expln for coal mining expls) 52) C.G. Dunkle, private communication, Jan 1968

Section 10

DETONATION (AND EXPLOSION) THEORIES.

Many theories have been proposed since the 1860's, of which only *hydrodynamic and hydrothermodynamic theories* (see at the end of this section) are universally adopted

Following is a list of various theories briefly described in this Encycl and in the References indicated below:

Abel Theory. See Detonation, Abel Theory or Theory of Synchronous Vibrations (Ref 103, p 22) in Section 2 and under History of in this Section

Absolute Reaction Rate Theory of Eyring;

Activated Complex- or Transition State- Theory. See "Absolute Rate Theory" in Vol 1 of Encycl, p A4-R and in Ref 96, p 134

Acoustical Theory of Shock Waves. See Ref 99, pp 206-08

Apin Theory. See Detonation (and Explosion), Penetrating- or Jet-Piercing Theory of Apin

Berthelot Theory. See Vol 2 of Encycl, p B106-L

Birkhoff-MacDougall-Pugh-Taylor Theory of Jet Formation. See next item

BMPT Theory of Jet Formation. See Detonation, BMPT (Birkhoff-MacDougall-Pugh-Taylor) Theory of Jet Formation in Shaped Charges, Section 2

Breaking Theory of Carl. See Vol 2 of Encycl, p B262 and Detonation (and Explosion), Breaking Theory of Carl in Section 2

Chapman-Jouguet Theory. Same as Hydrodynamic Theory, described in Section 2, pD235 and in Refs 5, 6, 7, 8, 39 (p 84), 57 (p 69), 84, 93 (p 169) & 96 (p 66)

Classical Theory of Plane Detonation Wave. See Detonation, Classical Theory of Plane Detonation Wave in Section 2

Conformal Solution (CS) Theories. See under Detonation, Longuet-Higgins (LH) Theory

Cook's Geometrical Model Theory. See Detonation, Geometrical Model Theory of in this Volume

Curved Front Theory. See Detonation, Curved Front Theory of Eyring et al in Section 2 and in Refs 51, 57 (p 150) & 93 (pp 188, 210 & 212)

DNZ Theory. See Detonation NDZ (vonNeumann-Doring-Zel'dovich) Theory

Expanding Jet Theory of Jones. See Detonation, Nozzle Theory of Jones and in Refs 57 (p 148) & 96 (p 123)

Eyring Absolute Reaction Rate Theory. See Absolute Rate Theory in Vol 1 of Encycl, p A4-R

Eyring et al Theory of Detonation. See Detonation, Curved Front Theory of Eyring et al in Section 2

Free Volume Theory for Liquids of Eyring. See Detonation, Free Volume Theory of the Liquid State Developed by Eyring et al in this Volume

Free Volume Theory of Lennard-Jones-Devonshire (LJD). See Detonation, Free-Volume Theory of the Liquid State etc in this Volume

Geometrical Model Theory of Cook. See Detonation, Geometrical Model Theory of in this Volume

Hydrodynamic Theory of Detonation. See further in this Section and in Refs 17, 29b, 44, 48, 52 (p 957), 57 (p 65), 68, 93 & 94

Hydrothermodynamic (or Thermohydrodynamic) Theory of Detonation. See further in this Section and in Refs 32, 39 (pp 87-8), 55a & 93

Jet-Piercing Theory of Apin. See Detonation (and Explosion) Penetrating or Jet-Piercing Theory of Apin and in Ref 38

Jones Detonation Theory. See Detonation, Nozzle Theory or Expanding Jet Theory of Jones

Kirkwood-Wood Detonation Theory. See Detonation, Wood-Kirkwood Theory

Lennard-Jones-Devonshire Theory. See Detonation, Free Volume Theory of the Liquid State by LJD (Lennard-Jones-Devonshire)

Longuet-Higgins (LH) Theory. See Detonation, Longuet-Higgins (LH) Theory

Mathematical Theory of Thermal Explosions of Frank-Kamenetskii. See under Detonation (Explosion, Deflagration and Decomposition), Thermal Theories and Thermochemistry of

Molecular Theory of Detonation. See Detonation, Molecular Theory of and in Refs 62 & 63

NDZ (vonNeumann-Döring-Zel'dovich) Theory. See Detonation, NDZ Theory

Nonlinear Theory of Unstable One-Dimensional Theory of Detonation. See Detonation, Nonlinear Theory of Unstable

Nozzle Theory of Jones. See Detonation, Nozzle Theory or Expanding-Jet Theory of Jones

Penetrating- or Jet-Piercing Theory of Apin. See Detonation (and Explosion), Penetrating or Jet-Piercing Theory of Apin

Perturbation Theories. See Detonation, Perturbation Theories of

Pseudopotential Theories. See Detonation, Pseudopotential Theories of

Qualitative Theory. See Detonation, Qualitative Theory of

Schweikert Theory. See Detonation, Schweikert Theory of

Spike Theory. See under Detonation, Spike Pressure and Spike Theory

Spinning Detonation, Theory of. See Detonation, Spinning Theory of, and in Ref 55b

Thermodynamic Theory of Detonation. See Detonation, Thermodynamic Theory of, and also R.L. Scovah, JChemPhys 3, 425-30(1935)

Thermohydrodynamic Theory of Detonation. Same as Hydrothermodynamic Theory of Detonation

Transition State Theory. See Absolute Rate Theory in Vol 1 of Encycl, p A4-R

Wood-Kirkwood Theory of Detonation. See Detonation, Wood-Kirkwood Theory of

ZND Theory. See Detonation NDZ (vonNeumann-Döring-Zel'dovich) Theory of

History of Detonation Theories Leading to Development of Hydrodynamic and Hydrothermodynamic Theories.

Accdg to Andreev & Belyaev (Ref 103, p 222) one of the first proposed theories of detonation was that of Abel (1869). It was known as the "Theory of Synchronous Vibrations" (Teoriya Sinkhronnykh Kolebanii, in Rus). Abel assumed that molecules of each expl vibrate during deton and thus incite vibrations of the surrounding medium at a frequency characteristic for each expl. The particles of the medium spread in all directions and, if another charge of the same expl is in the neighborhood, its particles start to vibrate in resonance and thus might initiate deton. This was an explanation of the phenomenon known now as "detonation by influence" or "sympathetic detonation". The propagation of deton in condensed expls was assumed to be caused by spread of vibrations in resonance with particles inside the expl. This theory was abandoned in 1883 in favor of the Berthelot Theory of Detonation, which is briefly described in Vol 2 of this Encycl, p B106-L. Berthelot's Theory was further developed by P. Vieille

Accdg to Baum et al (Ref 99, p 226), Berthelot & Vieille and, independently, Mallard & LeChatelier, observed detonation in gases as early as 1881 during their work with combustion of gases in pipes. They

showed that once a stationary regime is established, detonation propagates with a constant velocity reaching, for some gases, 3500-4000 m/sec, which values are much higher than the velocity of sound

The most important development for understanding detonation phenomena was the formulation of the theory now known as *hydrodynamic theory*. Baum et al, stated that Russian physicist V.A. Mikhel'son laid the foundation of the hydrodynamic theory as early as 1889, but his work remained unknown to Western Europe and the USA. The same person developed an equation and constructed a straight line, known in Russia as Priamaya Mikhel'sona ("Mikhel'son Straight Line"). The same line was described at about the same time by Lord Rayleigh and is known outside of Russia as "Rayleigh Line". In our opinion it is fair to call this line the *Rayleigh-Mikhel'son Line* (See eq 9 and Fig A under Detonation (and Explosion) in Gases and in Ref 11a)

Pioneers in development of hydrodynamic theory were Chapman (1899) (See Ref 5), Jouguet (1901 & 1905) (See Ref 6), Curssard (1907) (See Ref 6a) and some others. Among Russian scientists may be mentioned the names of Landau, Stanyukovich and Zel'dovich.

Important work on the theory of detonation process was performed during WWII in the US by Division 8 of NDRC under G.B. Kistiakowsky, by E.B. Wilson Jr and others. Summary of this work was given by S.R. Brinkley Jr in Ref 39, pp 83-88 and we are using this important work in compiling this section of the Encyclopedia

The NDRC review begins with a qualitative discussion of the building up of a "discontinuous shock front". Then the *Riemann formulation of the equation of hydrodynamics* is introduced. This formulation was published in 1860 (Ref 1)

These equations constitute a statement of the motion and continuity and for the plane case with adiabatic flow. They may be written:

$$\begin{aligned} \frac{\partial r}{\partial t} + (u+c) \frac{\partial r}{\partial x} &= 0 \\ \frac{\partial s}{\partial t} + (u-c) \frac{\partial s}{\partial x} &= 0 \end{aligned} \quad (1)$$

$$r = \frac{\omega + u}{2}$$

$$s = \frac{\omega - u}{2} \quad \text{and}$$

$$c^2 = \left(\frac{\partial P}{\partial \rho} \right)_s$$

where r and s are defined above, t =time, x =Euler coordinate of distance; u =particle velocity; ρ =density; P =pressure; c =velocity of small amplitude sound waves; and ω =Riemann function

The *Riemann function* defined by:

$$\omega(P) = \int_{\rho(P_0)}^{\rho} \frac{c}{\rho} d\rho \quad (2)$$

may be increased by an arbitrary constant. Since the pressure and density are connected by the adiabatic law (See Note), the Riemann function may be considered as a function of either the pressure or the density

Note 1: Dunkle (Ref 114) remarked that pressure and density are connected by the "adiabatic law" for only adiabatic transformations

From equations (1) it is concluded that r is constant along lines, called "characteristics", in the $x-t$ such that:

$$\frac{dx}{dt} = u + c \quad (r \text{ lines}) \quad (3)$$

and that s is constant along lines in the $s-t$ plane such that:

$$\frac{dx}{dt} = u - c \quad (s \text{ lines}) \quad (4)$$

Useful purposes of r and s lines are discussed in Ref 39, p 84-6, and the properties enumerated above were employed by the NDRC group in a discussion of the building up of the discontinuous shock or detonation front. A shock wave is produced by the acceleration of some generating surface. A detonation wave is self-maintained thru the energy received from the chemical reaction of the explosive

Additional information on *Riemann equation* is given in Dunkle's Syllabus (Ref 93, p 43). The same page gives definition of the *Riemann invariant*; p 187 gives formula for the *Riemann variant*; and p 260 gives formula for the *Riemann condition at the detonation front*. Evans & Ablow (Ref 108) describe *Riemann invariants* (p 133) and *Riemann equations* (p 144)

In our further discussion on detonation theories will be used [besides the NDRC Rept (Ref 39) and Dunkle's Syllabus (Ref 93)];

the works of Taylor (Ref 57), Morrison (Ref 58), Cook (Ref 99), Kistiakowsky, Wilson & Brinkley (Refs 29a, 29b & 32), vonNeumann (Refs 30 & 32b), and Evans & Ablow (Ref 108), as well as Dunkle's private communication (Ref 114)

Rankine-Hugoniot and Hugoniot Relations.

Analyses of flows involving deflagration and detonation fronts in gas have been made by Rankine (Ref 2), Hugoniot (Ref 2), Dixon (Ref 4), Chapman (Ref 5) and Jouguet (Refs 6 & 7). These analyses based on the laws of conservation of mass, momentum and energy predicted detonation velocities in good agreement with the experimental results obt'd from detonation in flame tubes

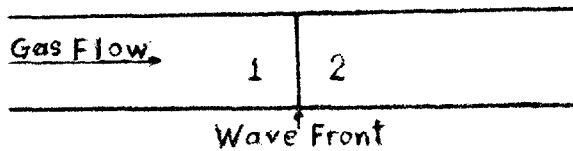

Fig 1. Flame Front in a Constant-Area Duct

Let us consider (as in Fig 1) a standing detonation or deflagration wave where subscript (1) denotes conditions before the front (unburned gases) and subscript (2) conditions after the front (burned gases)

Then: $\rho_1 u_1 = \rho_2 u_2$ is conservation of mass (5)

and $P_1 + \rho_1 u_1^2 = P_2 + \rho_2 u_2^2$ conservation of momentum, (6)

where P=pressure, u = particle velocity and ρ = density

Combining above equations and replacing ρ_1 with $1/v_1$ and ρ_2 with $1/v_2$, where v_1 and v_2 are specific volumes, we obtain:

$$(\rho_1 u_1)^2 = (\rho_2 u_2)^2 = (P_2 - P_1) / (v_1 - v_2) \quad (7)$$

When $(P_2 - P_1)$ is negative and $(v_1 - v_2)$ is negative *deflagration* is indicated and when $(P_2 - P_1)$ is positive and $(v_1 - v_2)$ is positive *detonation* is indicated. This shows that cases of deflgn are characterized by a pressure decrease and specific volume increase, whereas detons are accompanied by a pressure increase and sp vol decrease

Note 2: Morrison uses upsilon v to designate specific volume, but Dunkle advised changing it to v . He also changed the Morrison's expression $(v_2 - v_1)$ to $(v_1 - v_2)$

Note 3: Above eq 6 is the same as eq 92c on p 83 of Dunkle's Syllabus (Ref 93) and is, as noted on p 45 of Ref 93, derived from the constancy of mass velocity in a steady-state process of constant cross-sectional rea:

$$\dot{m} = u_1/v_1 = u_2/v_2 = \rho_1 u_1 = \rho_2 u_2$$

where \dot{m} = mass velocity, u = particle vel and v = sp volume

Despite the constancy of mass velocity, there is a change in the momentum per unit time because of the change in velocity. But time rate of change of momentum per unit area must balance the change of force per unit area, or of pressure:

$$P_2 - P_1 = m(u_1 - u_2) = \rho_1 u_1^2 - \rho_2 u_2^2 \quad (8)$$

whence comes the above eq (6)

This eq can also be written, as in the derivation of eq 92 on p 45 of Ref 93:

$$P_2 - P_1 = \frac{u_1}{v_1} u_1 - \frac{u_2}{v_2} u_2; \text{ but since } u_2 =$$

$\frac{u_1}{v_1} v_2$, we obtain:

$$P_2 - P_1 = u_1^2 \frac{v_1 - v_2}{v_1^2} = u_2^2 \frac{v_1 - v_2}{v_2^2} \quad (9)$$

or

$$\frac{P_2 - P_1}{v_1 - v_2} = (\rho_1 u_1)^2 = (\rho_2 u_2)^2 \quad (10)$$

which is the same as above eq (7)

Note 4: To avoid imaginary value of \dot{m} it is necessary either that both $(P_2 - P_1)$ and $(v_1 - v_2)$ be positive (as is the case of a detonation), or that they both be negative (as in a deflagration)

Note 5: Equation (7) can also be written as:

$$\frac{P_2 - P_1}{v_1 - v_2} = \left(\frac{u_1}{v_1}\right)^2 = \left(\frac{u_2}{v_2}\right)^2 \quad (7a)$$

The equations for the conservation of mass, momentum and total energy have been employed by Rankine (Ref 2) and Hugoniot (Ref 3) in the formulation of three conditions relating to pressure P_2 , specific volume v_2

and particle velocity u_2 of the medium behind the moving discontinuity; also to the velocity D of the discontinuity and the pressure P_1 , specific volume v_1 , and particle velocity u_1 of the undisturbed medium in advance of discontinuity:

$$D = u_1 + u_2 \sqrt{\frac{P_2 - P_1}{v_1 - v_2}} \quad (11)$$

$$u_2 = u_1 + \sqrt{(P_2 - P_1)(v_1 - v_2)} \quad (12)$$

$$e_2 - e_1 = \frac{1}{2}(P_2 + P_1)(v_1 - v_2) \quad (13)$$

where $e_2 - e_1$ is the difference in specific energy content of the material behind the front and undisturbed medium in advance of it.

Equation 13 is called the *Rankine-Hugoniot (R-H) Equation*, and in this form is valid for a detonation or a deflagration as well as for a shock wave

Dunkle remarked (Ref 114) that the energy equation expresses the fact that any decrease in enthalpy in the detonation must be balanced by an increase in kinetic energy and vice versa so that the sum of the two, the *stagnation enthalpy*, is conserved (Compare with eq 43r in Ref 93, p 34). This relationship can be expressed by writing:

$$h_1 + \frac{1}{2}u_1^2 = h_2 + \frac{1}{2}u_2^2 \quad (14)$$

$$= e_1 + P_1 v_1 + \frac{1}{2}u_1^2 = e_2 + P_2 v_2 + \frac{1}{2}u_2^2$$

where h is specific enthalpy.

Rearranging terms we obtain finally:

$e_2 - e_1 = \frac{1}{2}(P_1 + P_2)(v_1 - v_2)$, which is the same as the Rankine-Hugoniot equation listed above as eq 13

The eq in this form is valid for a detonation and a deflagration, as well as for shock wave, if e and h are defined in the usual sense

To apply this eq to explosions, however, some authors add a term Q to represent chemical energy per unit mass, and write:

$$e_2 - e_1 = Q + \frac{1}{2}(P_1 + P_2)(v_1 - v_2) \quad (15)$$

often called the *Hugoniot Equation* to show that the energy per unit mass in the detonation zone is increased not only by the shock compression in the detonation front but also by the release of chemical energy in the reaction zone (Compare with eq 94e of Ref 93, p 169)

Shifting Q in eq 15 to the left side and writing:

$$e_2 - (e_1 + Q) = \frac{1}{2}(P_1 + P_2)(v_1 - v_2) \quad (15a)$$

we obtain an expression which is equivalent to eq (13), if e_1 in eq (15a) is considered, as in normal usage, to include chemical energy

Nevertheless, Q is a convenient term, since its inclusion is a means of distinguishing between the *Hugoniot*s of the undetonated and the detonated mixtures. A separate R-H curve can be drawn for each step of the reaction as n (the fraction of the reaction completed) increases from 0 to 1, if for Q we substitute nQ . Then P , u and v become functions of n . The term Q can alternatively be used to express the internal energy increase from any source other than the shock compression; thus, if the heat is brought in from outside as by radiation, its magnitude must be added to the right side of the R-H equation to give the total increase in internal energy. (Ref 114)

Energy equation can also be expressed as:

$$h_2 - h_1 = \frac{1}{2}(P_2 - P_1)(v_2 + v_1) \quad (16)$$

where h is specific enthalpy

This eq is the same as eq 93a listed in Ref 93, p 45 and called by J.G. Coffin "the complement of the Rankine-Hugoniot equation"

If the term Q is introduced as in Hugoniot equation, we obtain:

$$h_1 - h_2 + Q = \frac{1}{2}(P_1 - P_2)(v_2 + v_1) \quad (17)$$

and there is no reason why it cannot be called (in analogy with the above) "the complement of the Hugoniot equation"

Substituting $e + P_v$ for h in eq (16), we obtain the Rankine-Hugoniot equation (same as eq 13) and, substituting the same term in eq (17), we obtain the Hugoniot equation (same as eq 15)

Accdg to Ref 39, p 84-R, the difference in specific energy content, $e_2 - e_1$, of the material behind the front and the undisturbed medium in advance of it, can be calcd by the following thermodynamic relation:

$$e_2 - e_1 = \frac{Q}{M} + \frac{1}{M} \int_{T_1}^{T_2} C_v^* v dt + \int_{\infty}^{v_2} \left(\frac{\partial e}{\partial v} \right)_{T_2} dv \quad (18)$$

where Q = heat of reaction at constant volume per M grams of reactant at the initial temperature T_1 ; C_v^* = constant volume heat capacity of M grams of products (gaseous products)

being considered in the ideal gas state); T_2 = temperature of the detonation front, which is related to pressure P_2 by an equation of state:

$$P = \int(Tv) \quad (19)$$

In the case of shock waves, where there is no chemical reaction, the above thermodynamic equation can be employed with $Q=0$
Note 6: Dunkle remarked that he does not know any detonative reactions that are endothermic (Ref 114)

Eqs (15) & (17) can be used not only for explosions, but also for detonations and deflagrations. For a fixed value of Q (i.e. a particular chemical reaction) and fixed values of v_1 & P_1 (i.e., particular initial conditions) this becomes an equation in P_2 & v_2 . Graphs of such an equation are called *Hugoniot curves*, or simply *Hugoniot*s. Along such curves lie the solution for deflgrn and deton processes. There are two main branches of these curves - one for deton processes and another for deflgrn processes. A region exists betw these two branches where "imaginary solutions" of the equation are obt'd indicating that states along this portion of the curve cannot exist (See Fig 2, reproduced from Ref 108)

Obviously there will be a Hugoniot curve for each assumed initial condition and each heat release, Q . Point O which does not lie on the H curve is the point corresponding to the initial state P_1 & V_1 (corresponding to P_0 & τ_0 of Fig 2). The curve itself is the locus of points describing all possible final states of the burned gas

Note 7: Point O of Fig 2 does not lie on the Hugoniot curve for any stage of reaction. It does, however, lie on the Hugoniot for the unreacted material (Refs 108, 112a, 113a, & 114)

From eq 13 it is seen that particle velocity u_1 is determined by the values of P_2 & v_2 . This vel is fixed in the case of deton by the slope of the straight line thru point O to point of tangency C on the *Hugoniot* of Fig 2. In the case of a deflagration, the vel is fixed by the slope of the straight line thru point O to the point of tangency D on the Hugoniot. These tangents, known in the US & Western Europe as Rayleigh Lines, are called in this work *Rayleigh-Mikhel'son Lines*. The waves corresponding to these slopes are called *Chapman-Jouquet detonations and deflagrations*, respectively

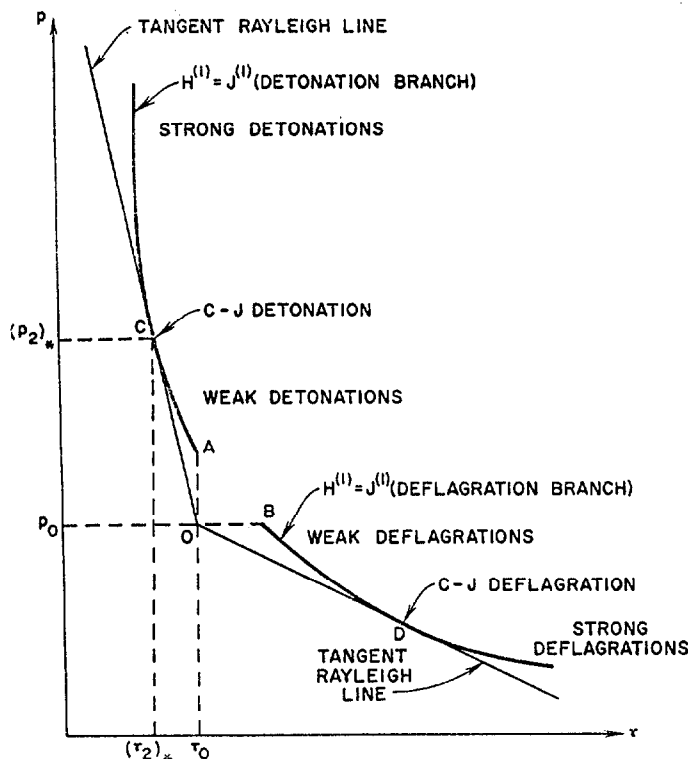

FIG 2 Hugoniot curve $H^{(1)} = J^{(1)}$ of reaction products, with sections corresponding to strong, Chapman-Jouquet, and weak detonations and deflagrations

The other waves are classified as follows: weak detonations, strong detons, weak deflagrations and strong deflagrations (Ref 58, pp 3-4 and Ref 108)

Note 8: Accdg to Dunkle (Ref 93, p 99): the Chapman-Jouquet theory deals with adiabatic transformations in steady, non-viscous, one-dimensional flows in stream tubes or ducts of constant cross-section. Pangborn & Foa (Ref 72a) call these transformations the *Rayleigh transformations*

Note 9: Dunkle also remarked (Ref 93, p 100) that Pangborn & Foa pointed out that in the ideal gas equation:

$$\frac{P_2}{P_1} - 1 = - \gamma M_1^2 \left(\frac{v_2}{v_1} - 1 \right)$$

P_2 & v_2 can represent pressure and specific volume at any station within the transformation region; P_1 & v_1 are pressure and specific volume of the undisturbed medium in advance of shock front; γ is C_p/C_v , the ratio of specific heats at const pressure & vol; and M_1 is

the Mach number of propagation into the undisturbed region

The meaning of the above equation is that for an ideal gas the path of the Rayleigh transformation in the dimensionless v, P plane (*Rayleigh-Mikhel'son line*) is a straight line of negative slope, and that the magnitude of the slope is proportional to the square of the Mach number of the propagation of the transformation into the undisturbed region ahead of it.

Note 10: The so-called *Fanno Line*, briefly described by Dunkle (Ref 93, pp 101-02) was more fully discussed by Shapiro (Ref 63a). It is briefly discussed in this write-up under Detonation, Fanno Line in

Accdg to Evans & Ablow (Ref 108, pp 139-40): Certain general statements can be made regarding the character of flow relative to the reaction front for six classes of reaction waves. The statements known collectively as **Jouguet's Rule**, assert that the flow relative to a steady reaction discontinuity is: a) Supersonic ahead of a detonation; b) Supersonic behind a weak detonation; c) Subsonic behind a strong detonation; d) Sonic behind a C-J detonation; e) Subsonic ahead of a deflagration; f) Subsonic behind a weak deflagration; g) Supersonic behind a strong deflagration; and h) Sonic behind a C-J deflagration. The above statements hold for polytropic materials or materials for which the equation of state (2.1.5) given in Ref 108, p 131, has the properties indicated on p 139. Fig 7 of Ref 108, reproduced here as Fig 3 shows a Hugoniot curve (heavy solid), Rayleigh-Mikhel'son lines (light solid) and adiabats (dashed) for such a system. Jouguet's rule is proved by showing that at a C-J point, the Hugoniot curve and the adiabat are both tangent to the Rayleigh-Mikhel'son line, and that in the regions of strong detonations and weak deflagrations the adiabats rise with increasing pressure more steeply and in the regions of weak detonations and strong deflagrations less steeply with increased pressure than the Rayleigh-Mikhel'son line

A more detailed description of proof of the Jouguet rule is given in Ref 108, pp 139-40 and in the book of Courant & Friedrichs (Ref 50, pp 215-22)

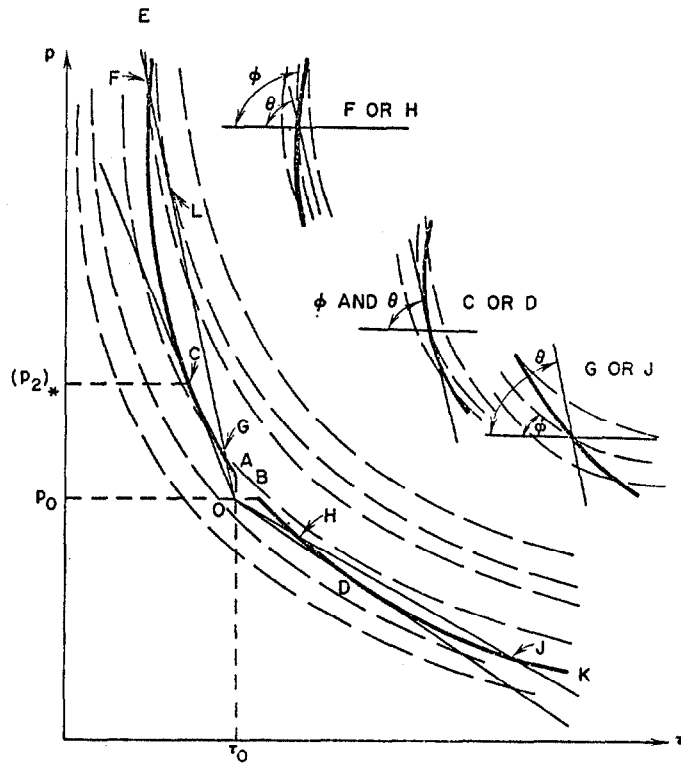

Fig 3 Hugoniot curve $H^{(1)} = J^{(1)}$ (heavy solid), Rayleigh-Mikhel'son lines (light solid), and adiabats (dashed)

Chapman-Jouguet (C-J) Condition and Postulate.

C-J condition is the condition that exists for a detonation or deflagration wave when the gases in the burned portion of the wave move at a velocity relative to the wave just equal to the local sonic velocity in the burned portion of the gas (Ref 58, p 4)

Accdg to S.R. Brinkley Jr (Ref 39, p 84-R), Chapman (Ref 5) and Jouguet (Refs 6 & 7) postulated that the detonation velocity is the minimum velocity compatible with the other conditions and that it can be expressed as:

$$D = u_2 + c_2 \tag{20}$$

$$D = u_2 + v_2 \sqrt{-\left(\frac{\partial P_2}{\partial v_2}\right)_s} \tag{21}$$

$$D = v_1 \sqrt{-\left(\frac{\partial P_2}{\partial v_2}\right)_s} \tag{22}$$

where subscript 2 refers to the conditions at the Chapman-Jouguet plane and subscript 1 to

the condition of the original undetonated explosive; subscript s is a constant along the s - t plane as defined in Equation 1 of this Section. [See also Detonation, Chapman-Jouguet Condition; Detonation, Chapman-Jouguet Hypothesis; Detonation, Chapman-Jouguet Postulate in Section 2 Dunkle's Syllabus (1957-1958), pp 54, 170 & 221-22 and Dunkle's Syllabus (1960-1961), pp 11.b & 14.f]

Arguments in support of Chapman-Jouguet Hypothesis were given by Becker (Ref 8), who extended it to solid expls and then by Scorah (Ref 15). However, no existing demonstration of the validity of this hypothesis is without theoretical objections. The eqs 20, 21 & 22 are employed particularly in the case of gaseous expls where there is less uncertainty as to the form of equation of state. If a suitable form of equation of state, $P = f(T, v)$, exists and if the compn of products of the expln reaction is known or can be determined, simultaneous solution of eqs 11, 12, 13 and 18, 19, 20, 21 & 22 permits the determination of the detonation velocity and of the pressure, as well as of specific volume and temperature of the detonation front (Ref 39, p 84-R)

Lewis & Friauf (Ref 11) have compared experimental values of the deton velocities for the expln of H_2 - O_2 mixts, both with and without the addn of an inert gas, with the predictions of theory, employing the ideal gas eq of state. When account was taken of dissociation equilibria of the product gases, good agreement betw theory and experiment was obtd. A study of deton velocities of solid expls has been made by Schmidt (Ref 17), who employed the Abel eq of state. His work was criticized in Ref 39, p 85-L

Kistiakowsky & Wilson (Ref 29a) calcd deton velocities of some gaseous and condensed expls using a modification of Becker's semiempirical eq of state. The calcd values were, in most cases, in fair agreement with exptl values. In their final rept (Ref 29b) a more general equation of state:

$$P_v M = nRT(1 + \chi e^{\beta\chi}); \quad \chi = \frac{k}{T^{1/4} M_v} \quad (23)$$

was employed, in which the coefficient β was included in the exponential term to secure constancy of the covolume constant k with respect to density of the gases, and in which a

$T^{1/4}$ dependence of the covolume upon temp was adopted. By trial, the value 0.3 was adopted for parameter β . A computational procedure was devised in which "ideal" values of the deton vel and temp were calcd on the assumption that the product gases obeyed the ideal gas law. The correction factors resulting from the introduction of eq 23 for the real gases were then tabulated as functions of the heat capacity of the product gases, considered ideal, and the argument

$$\chi_1 = \frac{\rho_1 k}{T_2^{1/4} M} \quad (24)$$

where ρ_1 = density of the intact explosive, T_2 = temp of detonation front, k = covolume constant and M = grams of products (Ref 39, p 85-R)

OSRD 114 (Ref 29b) contained also a discussion of shock and rarefaction waves based upon the "Riemann formulation of the equation of hydrodynamics". The Rayleigh (Ref 6b) solution of the Riemann equation for a *simple progressive wave* is given. In this case the Riemann's line (See our eq 1) is constant over a region and the r lines are therefore straight. Then

$$u = f[\chi - (u+c)t] \quad (25)$$

where f is an arbitrary function determined by the boundary conditions of the generating surface and the Rankine-Hugoniot conditions (See our eqs 11, 12 & 13), which are supernumerary boundary conditions which must be satisfied at the shock front

Rarefaction waves were also considered by Kistiakowsky & Wilson, and it was shown that in the case of rarefaction no discontinuity can occur and the detonation wave is followed by an advancing rarefaction wave. Tables, constructed by them with the aid of the eqs 11, 12 & 13, of the peak values of the temp, pressure, density, and shock wave velocity as functions of the peak value of the particle velocity for shock waves in air and water are given in Ref 29b

After the discussion of reflection phenomena at boundaries, a method was described for the calcn of the initial shock wave velocity for a shock wave initiated by a plane deton wave. It was also shown that the Riemann r (See our eq

1) must be constant across the boundary between expln products and exterior medium. This constant becomes half of the particle velocity of the expln products immediately behind the detonation front if the Riemann ω function for the exterior is defined as

$$\omega(\rho) = \omega \int_{\rho_2}^{\rho} \frac{c}{\rho} d\rho \quad (26)$$

where ρ_2 = density of the gases behind the deton front (Compare with our eq 2). Then

$$u_3 = -\omega + u_2 \quad (27)$$

where u_3 = initial particle velocity of the exterior medium and u_2 = particle vel behind the deton front

Since ω may be considered a function of ρ only, the initial shock pressure may be determined and the initial shock velocity follows from the R-H eqs 11, 12 & 13 (Ref 39, p 86)

A sample calculation was given in Ref 29b for shock waves in air employing the general equation of state (See eq 23) for the expln products and the ideal gas adiabatic eq of state for air. Employing the method of calculation based on the *hydrodynamic theory*, good agreement was obtained for expls investigated (PETN & Tetryl) between calculated and experimentally determined explosive properties

An extension of the procedure for calculating the deton velocities to include those expls which yield solid carbon as a reaction product has been accomplished by the same investigators (See Ref 32) on the assumption that the volumes of solid and gas are additive, that the gas obeys eq 23 and that the solid has zero coefficients of thermal expansion and basic compression. The composition of the reaction products was assumed to be that of chemical equilibrium at the temp and pressure immediately behind the deton wave, and a numerical procedure, involving successive approximations, was developed for the determination of the composition from a consideration of the simultaneous equilibria involved. This method of calculation was briefly discussed in Ref 39, pp 86-7

As a consequence of the determination of the composition at equilibrium of the products of expln reaction, it has been shown that a good approximation to the composition is afforded by the following conventional scheme:

In listing the products of the reaction, it can be assumed that oxygen reacts first with hydrogen with quantitative formation of water, the remaining oxygen reacts with carbon to form its monoxide, and additional oxygen, if any, reacts with CO to form dioxide. The decomposition scheme suggested by Kistiakowsky & Wilson results from a consideration of the water-gas equilibrium in which the effect of the nonideality of the gases is not included. The effect of gas imperfections is to reverse this equilibrium completely, thus giving rise to the conventional decomposition scheme.

The detonation velocity is insensitive to the composition of the explosion products, and calculations based upon the conventional decomposition scheme differ little from the much more elaborate calculations which include the determination of the equilibrium composition. The covolume constants can be determined from experimental values of deton velocities of selected expls by an extensive series of successive approximations which were outlined in Ref 32. The *hydrothermodynamic theory* described in the same Report was used in calculations. The final values of the constants for the individual gas species were found to be closely proportional to the high temp values of the van der Waals b as evaluated by Hirschfelder et al (Ref 29c)

The computational method for determination of deton velocities, described in Ref 32, was used in determination of velocities, temps, densities and pressures of detonation front for 16 pure organic expls. Comparisons of calculated velocities with experimental values were possible for 12 expls. Agreement was satisfactory for 7 of these, while for remaining 5 expls the calculated values for velocities were lower than the experimental values

About 1943, a simplified method for calculation of deton velocities of solid organic expls was developed at the Explosives Research Laboratory (ERL), Bruceton, Pennsylvania. As there was no report issued at that time but just an unpublished letter of E.M. Boggs & F.J. Martin addressed to Brinkley, a brief description of the method was given by him in Ref 39, p 87

In the ERL method, the general equation of state (See our eq 23), with a single covolume constant per unit mass of gaseous expln product, was used and the decomposition scheme which leads to quantitative formation of water,

was employed to estimate the compn of the products. The covolume constant was evaluated by use of exptl values of the deton velocity of oxygen-rich expls. The specific volume of solid carbon was treated as an adjustable parameter and its value was detd by the use of exptl values of the deton velocity of oxygen-deficient expls. The best agreement betw theory and experiment was obtd with a covolume constant of 12.7 per gram of gaseous product and with a value of 0.340cc (in lieu of previously used 0.3) per gram for the specific volume of carbon. With these parameters the calcd and exptl values of deton velocities agreed within 6%

By 1946, the best exptl values of the deton velocities had become somewhat different from 1943 values employed by Boggs & Martin and this resulted in a somewhat different value of the covolume constant. A small residual variation in the covolume constant with density of expl suggested that the parameter of eq 23 should be re-evaluated. It was felt that the use of a $T^{1/3}$ (in lieu of $T^{1/4}$) dependence of the covolume on temperature (which would necessitate the re-evaluation of both the covolume constant and β) would improve the agreement betw theory and experiment for "cold" expls (expls with low temp of deton, like NGu) without sacrificing the excellent agreement obtd by Boggs & Martin for the expls with higher deton temps (Ref 39, p 87). The hydrothermodynamic theory of detonation described in Ref 32 was used in calculation of expl properties of Amatex, 50/50-Amatol, 60/40-Amatol, TNT & Composition B

Calculations of pressures developed on detonation were made by Brinkley & Wilson for several explosives as described in OSRD Repts 1231 & 1510 (Refs 32b & 33a)

Hydrodynamic- and Hydrothermodynamic-Theories of Detonation.

Hydrodynamic theory, strictly speaking, considers only fluid motion, whereas *hydrothermodynamic* (called *thermo-hydrodynamic* by Cook) *Theory* considers also heat effects. One might say that the *hydrodynamic theory* is based on the laws enumerated in treaties on "fluid mechanics", or "hydrodynamics", such as in the books: 1) R.H. Sabersky & A.J. Acosta,

"Fluid Flow: A First Course in Fluid Mechanics", Macmillan, NY (1964), 393 pp
2) B. Adler, S. Fernbach & M. Rotenberg, "Fundamental Methods in Hydrodynamics, Methods in Computational Physics", Vol 3, Academic Press, NY (1964), 398 pp. The *hydrothermodynamic theory*, however, combines the laws of "hydrodynamics" with the laws concerning relationship between heat and motion as enumerated in treatises on "thermodynamics", such as in: 1) S.R. de Groot, Intern J Heat Mass Transfer 4, 63-70 (1961) & CA 57, 4110 (1962) 2) N.O. Smith, "Chemical Thermodynamics, A Problem Approach", Reinhold, NY (1967), 278 pp

Accdg to Dunkle's Lecture delivered at Picatinny Arsenal on Dec 13, 1955, "Hydrodynamic Theory of Detonation", (Ref 78), utilizes the laws of conservation of mass, energy and momentum to derive certain relationship known as the "Rankine-Hugoniot Equation". There are five basic equations, of which the first three are related to five variables: pressure, specific volume, energy, detonation velocity and particle velocity.

As none of these equations is listed in Dunkle's Lecture, we take them from other sources, mostly from Cook (Ref 96)

The *law of conservation of mass (or matter)* states that total mass of any system remains constant under all transformations. It can be expressed by the equation (as given by Cook in Ref 96, p 61):

$$D^2 = v_1^2 (p_2 - p_1) / (v_1 - v_2) \quad (4.3)$$

The *law of conservation of energy* states that the total energy in a closed system remains constant. It can be expressed by the equation:

$$W^2 = (v_1 - v_2) / (p_2 - p_1) \quad (4.4)$$

The *law of conservation of momentum* states that the quantity of motion of a moving body, equal to the product of its mass and velocity, remains constant in a closed system. It can be expressed by the equation:

$$e_2 - e_1 = \frac{1}{2}(p_2 + p_1) / (v_1 - v_2) \quad (4.5)$$

Equation (4.5) is known as the Rankine-Hugoniot equation. The symbols used in the above three equations, which are applied to

the steady-state (constant velocity) detonation wave are as follows: D = deton velocity; p_1 = original pressure of explosive; p_2 = pressure at Chapman-Jouguet plane; v_1 = original specific volume; v_2 = sp vol at C-J plane; W = particle velocity; and e = specific energy (Cook gives E , usually reserved for total energy)

Further in his lecture Dunkle stated that the fourth expression used in hydrothermodynamic theory of detonation calculation is the equation of state formulated by Sir F. Abel at the end of the 19th century. This simple equation, described in Section 3, DETONATION (AND EXPLOSION), EQUATIONS OF STATE IN, is still frequently used. It gives fairly accurate results for low loading density condensed expls, but for higher densities, Evans & Ablow recommend more complicated equations, as for example, that of Boltzmann (Ref 108, p 131)

Still further in his lecture Dunkle stated that the fifth equation is obtd by assuming that the deton velocity is the sum of the particle vel and the velocity of sound in the deton products at their equilibrium temperature and pressure:

$$D = d + c$$

where D = deton vel, d = vel of products of deton, known as particle vel (designated also as u), and c = sonic vel equal to 331.9 m/sec

All this, incidentally, is consistent with the inability of any rarefaction to overtake the "detonation front" (under conditions of sufficient confinement), for it cannot "cut into" the "detonation zone" any faster than the speed of sound in the products. But if such an expansion would not take place, the length of the column of the products would keep increasing at the rate of $(D-d)=c$. All that the expansion or the rarefaction can do, therefore, is to keep the thickness of the "detonation front" from increasing

The above mentioned five independent relationships are sufficient to give the five values sought: pressure, density, energy (or temperature), detonation velocity and particle velocity

Simultaneous solution of the above five equations gives us an insight into the conditions in the detonation zone and a view of the mechanism of detonation. Also the "detonation

parameters" of any substance which is being considered for use as an explosive can be calculated and correlated with other physical and chemical properties. For these reasons, the above equations are important and useful in the explosives industry.

Cook (Ref 96), continuing his discussion on p 61, stated after equation (4.5) that if one adopts a general equation of state in the forms:

$$pv = nRT + a(T, v)p \quad (4.6)$$

where a is covolume and n = mol gas/kg, then from the C-J conditions [Eqs (4.1) or (4.2)] and the 2nd Law of Thermodynamics for adiabatic conditions, $TdS = C_v dT + [p + (\partial e / \partial v)_T] dv = 0$:

$$-\frac{p_2 - p_1}{v_1 - v_2} = \left(\frac{\partial p_2}{\partial v_2} \right)_{H_1} = \frac{-p_2 \beta}{v_2 - a} \quad (4.7)$$

where:

$$\beta = \frac{C_v + nR}{C_v} - \left(\frac{\partial a}{\partial v_2} \right)_S + \frac{nR}{C_v p_2} \left(\frac{\partial e}{\partial v} \right)_T \quad (4.8)$$

By substituting eq (4.7) in eqs (4.3) to (4.5), one then obtains for condensed expls [where in general $p_2 \gg p_1$ and the variation of n with ρ_1 (or ρ_2) is neglected]:

$$D = v_1 (v_1 - a)^{-1/2} (\beta + 1) \beta^{-1/2} (nRT_2)^{1/2} \quad (4.9)$$

$$W = (nRT_2)^{1/2} \beta^{-1/2} = (e_2 - e_1)^{1/2} 2^{1/2} \quad (4.10)$$

$$T_2 = (Q + T_1 \bar{C}_v) \beta / (\beta \bar{C}_v - 1/2 nR) \quad (4.11)$$

where symbols not explained previously include: H = enthalpy, or heat content; S = entropy; V = specific volume; Q = heat of expln and \bar{C}_v = average heat capacity at const volume

In computing the hydrothermodynamic properties of expls, one requires in addition to eqs (4.6), (4.9), (4.10) and (4.11), the composition of the products of detonation, from which to obtain Q , C_v , and n in eq (4.11) from:

$$n = \sum_i n_i; \quad C_v = \sum_i n_i C_{vi}; \quad \text{and} \quad Q = \sum_i n_i Q_i - \Delta H_f$$

where subscript i refers to the i th component (of the product) mixture and ΔH_f is the heat of formation of the explosive. This problem may be handled thermodynamically by including in the simultaneous solution of eqs (4.6) to (4.11),

the eqs defining the products thru the appropriate equilibrium constants. For the general equation of equilibrium:

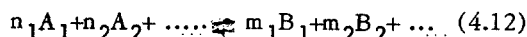

the thermodynamic equilibrium constant is:

$$K_p(T) = \frac{f_1^{n_1} f_2^{n_2} \dots f_{B_1}^{-m_1} f_{B_2}^{-m_2} \dots}{A_1^{n_1} A_2^{n_2} \dots B_1^{m_1} B_2^{m_2} \dots} = \frac{\prod_i f_i^{\nu_i}}{\prod_j f_j^{\nu_j}} \quad (4.13)$$

Using the definitions $a = v^{-1} a$ and $K_i = K_p (1.2181/T)^{\Delta \nu_i}$;

$$\Delta \nu = \sum_i n_i - \sum_j m_j$$

one obtains finally (thru the thermodynamic relations defining fugacity as shown in Appendix II):

$$K = \frac{\prod_i A_i^{\nu_i}}{\prod_j B_j^{\nu_j}} a^{-\Delta \nu} \exp \left[\frac{\Delta \nu}{nRT_2} \int_0^p a \, dp \right] = \frac{\prod_i A_i^{\nu_i}}{\prod_j B_j^{\nu_j}} F^{\Delta \nu} \quad (4.14)$$

Meanings of symbols used in eqs (4.12), (4.13), (4.14) and (4.15) are probably given in Cook's papers listed here as Ref 48. Meanings of symbols are given in Cook's book, pp 376-78

Tables of thermodynamic data necessary to apply equations listed by Cook are given in Appendix II of his book. The complete solution of the thermohydrodynamic theory for condensed explosives may then be effected in principle by a simultaneous solution of eqs (4.6) to (4.15), inclusive, providing all equilibrium constants of eqs (4.12) to (4.15) are known, together with the necessary heat data. However, in actual fact this application of eqs (4.6) to (4.15) requires that $\alpha(T, v)$ be more explicitly defined (Ref 96, p 62)

This can be done by substituting in eq (4.6), $\alpha(T, v)$ by $nRT_2 x e^{bx/p_2}$, as was done by Kistiakowsky & Wilson (Ref 29b) and by Brinkley & Wilson (Ref 33b) in collaboration with Halford. In their eq which is listed by Cook as (4.16), under the name H-K-W-B, $x = k(T+d)^a v^{-1}$, $a = -1/4$ and $b = 0.3$. The covolume constant k was taken as $k = \sum_i x_i k_i$, where x_i is the mol fraction of component i in the products of deton and k_i is a specific covolume constant for each type of molecule. Cook (Ref 93, p 63) adopted the covolume approximation:

$$\alpha(T, v) = \alpha(v) \quad (4.17)$$

and later studied with his associates the eqs of state obtd by taking:

$$\alpha(T, v) = v(1 - e^{-x}); \quad x = K(v)T^c v^{-1} \quad (4.18)$$

employing various values of c and the "inverse method", i.e., by making use of experimental velocity data to evaluate the function $K(v)$. The eq (4.18), by adjusting the const c , can be made as nearly like any of the special forms employed by the various investigators as is desirable and thus is able to bring out the particular characteristics of each of those special forms. Thus, by taking $c = -0.25$, this eq closely resembles the H-K-W-B eq. Further studies of Cook et al, were on the influence of changes in the internal pressure p_i , and corresponding internal energy E_i on the calcd deton properties. The main conclusions of these studies were:

1) Only the temperature of detonation, T_2 , is influenced sufficiently by differences in the form of $\alpha(T, v)$, leading to relatively large differences in p_i , to allow one to determine, from the hydrodynamic theory and experimental measurements, the correct form of $\alpha(T, v)$. In this eq one obtains (in final form):

$$P_1 = P_2 c^x \quad (4.19)$$

2) Perhaps the best possible approach toward finding the true eq of state would therefore be a thorough empirical study of the T_2 versus p_1 relations for different expls. This study is discussed in Cook's Chapter 6

That the approximation eq (4.17) may be the correct one is indicated by close agreement of all computed $\alpha(v)$ curves obtd in solutions of the hydrodynamic theory using this approximation, together with exptl velocity data to derive $\alpha(v)$. Results of Cook's work is illustrated in Fig 4.12, p 64, given here as Fig 5

Further in the Chapter 4 devoted to "Thermodynamic Theory and Mechanism of Detonation", Cook discusses other equations of state (pp 63-66), but more detailed information on this subject is given in Section 3, DETONATION (AND EXPLOSION), EQUATIONS OF STATE IN

Cook also discusses in the same Chapter the Chapman-Jouguet Postulate (pp 66-8), Detonation Reaction Zone in Gases (pp 68-75), Reaction Zone in Nonideal Detonation in

Gases (pp 75-7); Reaction Zone in Condensed Explosives (pp 77-9); Observations Pertaining to Spike Theory (pp 79-87) and Heat Pulse (pp 87-9)

Computer Methods called HEMP, TIGER &

RUBY are described under Computers and Computer Programs in Section I of this Volume

(Compare "Detonation Theories" with "Combustion Theories as Applied to Solid Propellants", described in Vol 3 of Encycl, pp C430 to C433)

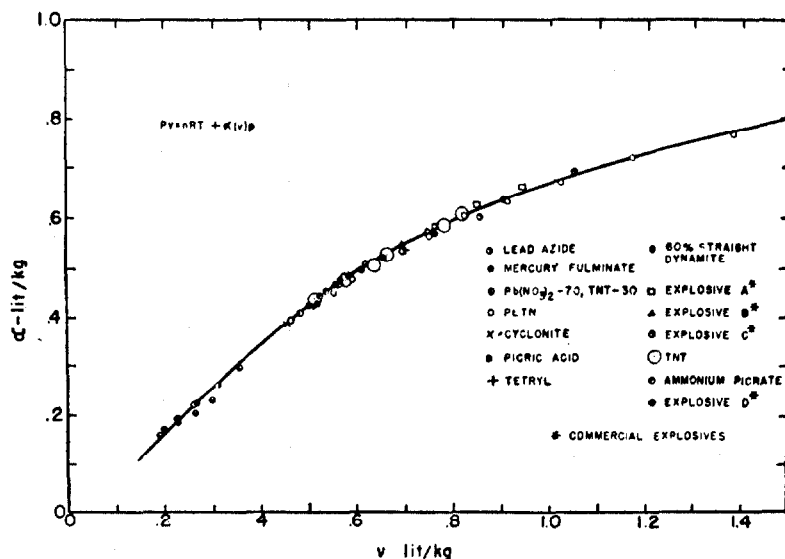

Fig 5. Correlation of explosives by $\alpha(v)$ equation of state

Refs: 1) B. Riemann, *AbhGesWissGöttingen*, **8**, 43 & 156(1860) 2) W.J.M. Rankine, *PhilTransRoySoc(London)* **160A**, 270(1870) 3) J. Hugoniot, *Journal de Mathématique (Paris)* **3**, 477(1887); *Journal de l'École Polytechnique (Paris)* **57**, 3(1887) & **58**, 1(1888) 4) H.B. Dixon, *PhilTransRoySoc*, **184A**, 97(1893) (Studies of detonation of various gaseous mixtures 4a) É. Sarrau, "Théorie des Explosifs," Gautier-Villars, Paris (1895) 5) D.L. Chapman, *PhilMag & J of Science, Ser 5*, **47**, 90-104(1899) & *JCS* **76** II, 591(1899) (On the rate of explns in gases) 6) É. Jouguet, *CR* **132**, 573(1901) & *CA* **1**, 1970(1907); *Ibid*, *Journal de Mathématique* (6) **1**, 347-425(1905) & (6) **2**, 5-86(1906) (On the propagation of chemical reactions in gases) 6a) Crussard, de M, *CR* **144**, 417(1907) 6b) Lord Rayleigh, *PrRoySoc(London)* **84A**, 247(1910) 7) É. Jouguet, "La Mécanique des Explosifs", O. Doin et Fils, Paris (1917)

8) R. Becker, *Zeitschrift für Physik* **8**, 321-62(1922) (Shock waves and detonation; application of Chapman-Jouguet theory to solid expls) 9) G. Schweikert, "Innere Ballistik", Springer, Leipzig(1923), 31 ff (Theory of deton of solid & liq expls) 10) H. Muraour et al, *Bull (Fr)*, (4) **39**, 1711(1926); **41**, 620(1927) & **51**, 1152(1932); *Ibid Chim & Ind (Paris)* **20**, Oct(1927), **29**, March(1933) & **30**, July(1933) (Theories of deton) 11) B. Lewis & J.B. Friauf, *JACS* **52**, 3905-20(1930) (Explns in detonating gas mixtures) 11a) V.A. Mikhel'son, "Collective Works", *IzdatNovyiAgronom*, Moscow, Vol 1(1930) 11b) Vennin, Burlot & Lécorché (1932), 121-58 (Detonation of expls) 12) M. Sukharevskii & F. Pershakov, "Teoriya Vzryvchatykh Veshchestv" (Theory of Explosive Substances), Gosizdat, Moscow (1932) 13) W. Friederich, *SS* **28**, 2, 51, 80, 113, 213 & 244 (1933) (Detonation of expls) 14) K.K. Snitko, "Teoriya

- Vzryvchatykh Veshchestv'' (Theory of Explosive Substances), Izdatel' stvo Artilleriyskoy Akademiiye, Moscow, Vol 1 (1934) & Vol 2 (1936) 15) R.L. Scorah, JChemPhys **3**, 425-30(1935) (On the thermodynamic theory of detonation) 16) H. Muraour, SS **30**, 1-6 (1935) (On the theories of expl reactions) 17) A. Schmidt, SS **30**, 320 & 364(1935); **31**, 63, 92 & 322(1936) (Determination of velocities of deton employing hydrodynamic theory) 18) M. Majrich, MAF **15**, 367-78(1936) (Contribution to theory of explns) 19) N.A. Sokolov, "Teoriya Vzryvchatykh Veshchestv'' (Theory of Explosive Substances), ONTI, Moscow (1937) 20) W.E. Gamer, TrFaradSoc **34**, 985-89(1938) (Deton & Expln arising out of thermal decompn) 21) H. Muraour, TrFaradSoc **34**, 989-92(1938) (Theory of expl reactions) 22) A. Schmidt, SS **33**, 121-25 (1938) (Expln & deton considered from a molecular-kinetic standpoint) 23) Ibid, **33**, 280-83 & 312-15(1938) (The deton of expls and the influence of their mechanical condition) 24) B. Lewis & G. vonElbe, "Combustion, Flames and Explosions of Gases", OxfordUnivPress, London (1938) 25) T. Urbański, SS **34**, 103-05(1939) (Concerning the deton of smokeless proplnts) 26) K.K. Andreev & Yu.B. Khariton, "Teoriya Vzryvchatykh Veshchestv'' (Theory of Explosive Materials), Oborongiz, Moskva (1940) 27) K.K. Andreev, KhimReferatZh. **1940**, No 10-11, p 122 & CA **37**,1604(1943) (The quantitative hydrodynamic theory of decompn of expls regards only the stationary distribution of deton without taking into account the mechanism of kinetics of the reaction. On the basis of kinetics and the chain character of the reactions, Andreev discusses the mechanism of the decompn of primary & secondary expls. The activation energy of primary expls is considerably smaller than that of secondary expls, whereas the energies of the reaction products are approx identical. An explanation is given of the formation of deton by slow thermal decompn of various reaction products) 28) S.B. Ratner, ZhFizKhim **20**, 1377-80(1946) & CA **41**, 3297(1947) (Mechanism of deton of liquid expls) 29a) G.B. Kistiakowsky & E.B. Wilson Jr, OSRD Rept **69** (1941) (Prediction of detonation velocities of solid expls) 29b) Ibid, OSRD **114**(1941) (Hydrodynamic theory of deton and shock waves) 29c) J.O. Hirschfelder et al, OSRD **547**(1942) (Thermochemistry and the equation of state of the propellant gases) 30) J. von Neumann, OSRD **549**(1942) (Theory of deton waves) 31) G.G. Kirkwood & G.M. Richardson, OSRD **813**(1942) (Vel of shock waves in sea water) 32) S.R. Brinkley Jr & E.B. Wilson Jr, "Revised Method of Predicting the Detonation Velocities in Solid Explosives", OSRD **905** (1942) (Included in the report is a discussion on hydrothermodynamic theory) 32a) J. von Neumann, OSRD **1140**(1942) (Discussion on the theory of stationary deton waves) 32b) S.R. Brinkley Jr and E.B. Wilson Jr, OSRD **1231**(1943) (Calculation of detonation pressure of several expls) 33a) Ibid, OSRD **1510** (1943) (Calculation of the detonation properties of some service explosives) 33b) Ibid, OSRD **1707**(1943) (Calculation of detonation velocities of some pure organic explosives) 34) W. Döring, AnnPhysik **43**, 421 (1943) (Contribution to theory of deton) 35a) G.B. Kistiakowsky & H.J. Fischer, "Detonation, Fragmentation and Air Blast", NDRC Interim Rept **DF-20**, period Sept 1943-Aug 1945 35b) S.R. Brinkley Jr et al, "Tables of the Properties of Air along the Hugoniot Curve and the Adiabatics Terminating in the Hugoniot Curve", OSRD Rept **3550** (1944) 36) L.H. Thomas, "Theory of the Explosion of Cased Charges of Simple Shape", BRL **475**(1944) 37) R.W. Lawrence, Geophysics **9**, 1-18(1944) & CA **38**, 3477(1944) (Mechanism of deton in expls) 37a) Vivas, Feigenspan & Ladreda, Vol 1(1945), 55-100 and Vol 4(1945) (Theory of explosions), 38) A.Ya. Apin, DoklAkadN **50**, 285-88(1945) & CA **44**, 1032(1950) (Penetrating or piercing jet theory of deton) 39) S.R. Brinkley Jr, "The Theory of Detonation Process", pp 83-8 in the "Summary Technical Report Division 8, NDRC", Vol I(1946). It includes: Riemann formulation (pp 83-4 & 86); Rankine-Hugoniot condition (84 & 86); Chapman-Jouguet postulate (84); Becker semiempirical equation of state (85); Rayleigh solution of the Riemann equation (86); and Hydro-thermodynamic theory, applications (87-8) 40) W. Loring & H. Schardin, "Detonation of Explosives" (A review), FIAT RevGerSci 1939-1946, Hydro- and Aerodynamics **1948**, 97-125 & CA **46**,

- 3761 (1952) 41) W. Jost, "Explosion and Combustion Processes in Gases", McGraw-Hill, NY (1946) 42) R.J. Finkelstein & G. Gamow, "Theory of Detonation Process", NavOrdRept **90-46** (1947) 43) H. Jones, PrRoySoc **189A**, 415 (1947) (Nozzle theory of deton) 44) G. Morris & H. Thomas, Research (London) **1**, 132-44 (1947) & CA **44**, 10321-22 (1950) (Hydrodynamic theory of deton) 45) Ya. B. Zel'dovich & V. V. Voyevodskii, "Kurs Teorii Goreniya, Detonatsii i Vzryva" (A Course on the Theory of Combustion, Detonation and Explosion), Vol 1 (1947) and Ya. B. Zel'dovich & D. A. Frank-Kamenetskii, Vol 2 (1947), IzdatMoskMekhInst, Moskva. Reviewed in UspekhiKhimii **17**, 277-78 (1948) & CA **43**, 8140 (1949) 45a) Muraour (1947), 41-59 (La détonation des explosifs) 46) N. Manson, "Propagation des Détonations et des Déflagrations dans les Mélanges Gazeux", L'Office Natnl d'Études et des Recherches Aeronautiques; L'Institut Français des Petroles, Paris (1947) 47) H. Jones & R. Miller, PrRoySoc **194A**, 480-507 (1948) (Deton of solid expls) 48) M. A. Cook, JChemPhys **15**, 518-24 (1947); Ibid **16**, 554-55, 1081-86 & 1185 (1948) (An equation of state for gases at extremely high pressures and temps from the hydrodynamic theory of deton) 49) R. H. Cole, "Underwater Explosions", Princeton UnivPress, Princeton, NJ (1948), Chapter 3 50) R. Courant & K. O. Friedrichs, "Supersonic Flow and Shock Waves", Interscience, NY (1948) (Reprinted in 1961) 51) A. Eyring et al, ChemRevs **45**, 69-181 (1949) & CA **43**, 8139 (1949) [A review of work on detonation done during WWII in the US under the auspices of OSRD (Office of Scientific Research and Development) and of the Bureau of Ordnance of the Navy Department. It includes a critical résumé of the classical theory of deton wave, followed by a presentation of the theories developed for deton in finite charges, time-dependent deton, and failure of deton. The curved-front theory of deton in the non-ideal deton wave is discussed on p 99 and the stability of deton on p 101] 52) G. B. Kistiakowsky, "Theory of Detonation of Explosives", pp 948-60 in Kirk & Othmer **5** (1950). It includes: Theory of shock wave (pp 949-52); Rankine-Hugoniot equation (951); Theory of stationary deton wave (952-55); Calcn of deton parameters (955-57); Deviations from hydrodynamic theory (957-59); Initiation and mechanism of deton (951-60) (Theory of detonation is not discussed in the 2nd ed of Kirk & Othmer) 52a) J. von Neumann & R. D. Richtmayer, JApplPhys **21**, 232-37 (1950) (A method for numerical calcns of hydrodynamic shocks) 53) W. G. Penney, PrRoySoc **204A**, 1-8 (1950) & CA **45**, 10587 (1951) (A review of the development of deton theories; subjects treated include: steady & nonsteady deton, deton zone, deton process, and nonplanar deton fronts) 54) H. Jones, PrRoySoc **204A**, 9-12 (1950) & CA **45**, 10585 (1951) (A mathematical procedure for discussing the problem of deton of a cylindrical solid as distinct from gas confined in a tube) 55a) S. Travers, MAF **24**, 441-553 (1950); **25**, 421-624 (1951) (État Actual et Valeur de la Théorie Hydrothermodynamique des Explosions et Chocs) (Present status and value of hydro-thermodynamic theory of explns & shocks) 55b) J. A. Fay, JChemPhys **20**, 942-50 (1951) (Theory of spinning detonation) 56) B. Lewis & G. vonElbe, "Combustion, Flames and Explosions of Gases", Academic Press, NY (1951) 57) Taylor (1952), 1-9 (General introduction and definition of deton, deflgrn & expln); 33-39 (Equation of state of the expln products); 65-69 (Hydrodynamic theory of deton); 69-80 (Rankine-Hugoniot equation and Chapman-Jouguet stability condition); 80-83 (Deton in ideal gases); 83-86 (Deton in real gases and dust clouds); 87-110 (Deton in condensed expls yielding only gaseous products); 111-38 (Deton in expls whose products contain a condensed phase); 148 (Expanding-jet theory of Jones); 150 (Curved front theory of Eyring); 176 (Grain Burning or surface burning theory of deton) 57a) Anon, "Ordnance Explosive Train Designers' Handbook", USGovtPrinting-Office, Washington, DC (1952), pp G1 to G3 58) R. B. Morrison, "Shock Tube Theory as Applied to Detonative Processes", WillowRun-ResearchCenter, Univ of Michigan Rept **UMM-97** (1952) 59) A. Langhans, Sprengtechnik **1952**, 73-7 & CA **46**, 8374 (1952) (Classification of burnings and explns) 60) S. Travers, MAF **27**, 699-856 (1953) & CA **48**, 12409 (1954) (Discussion on deton, deflgrn, etc of condensed expls) 61) T. Hikita, JIndExplsSoc Japan **13**, 3-8 & 77-85 (1952); CA **49**, 2736 (1955)

- (Progress in detonation theory) 62) T. Kihara & T. Hikita, *Ibid*, 106-13 (1952) (Engl summary of molecular theory of detonation), CA **49**, 5841 (1955) 63) T. Kihara & T. Hikita, pp 458-64 in 4thSympCombstn (1953) & CA **49**, 6608 (1955) 63a) A.H. Shapiro, "The Dynamics and Thermodynamics of Compressible Fluid Flow", 2 vols, Ronald Press, NY (1953) 64) E.N. Clark, "Detonation Theory", Lecture, PicArns, Dover, NJ (1953) 65) K.K. Andreev, "Vzryv" (Explosion), Gosizd TekhTeorLit, Moskva (1953) 66) S. Paterson & J. Davidson, *JChemPhys* **22**, 150 (1954) & CA **48**, 4911 (1954) (Equations of state and detonation theory) 67) B.J. Zwolinski, "Some Thoughts and Speculations on Explosives", Stanford ResearchInstitute-IntRept **SRI 014-54** (1954) 68) D. Smolenski, "Teoria Materialów Wybuchowych" (Theory of Explosive Substances), WidMinistOborony-Narodowej, Warczawa (1954) 69) H.E. Watts, "The Law Relating to Explosives", Griffin, London (1954) 70) G.I. Pokrovskii, "Vzryv" (Explosion), VoenizdatMinistObor, Moskva (1954); Engl excerpt by Maj G.K. Kudrávetz, USAF, OTIA 1450 (1958) 71) M.A. Cook et al, *TrFaradSoc* **52**, 369-84 (1954) (Mechanism of deton) 72) K. Flick, *Explosivstoffe* **1954**, 42-44 (Observation on detonation process) 72a) D.F. Pangburn et al, "An Extension of the Chapman-Jouguet Gasdynamics of Combustion", Rensselaer Polytechnic Institute, TechRept **AF 5402**, Feb 1954, ONR Contract Monr 591 (04), NR No 094-264 73) F.C. Gibson & C.M. Mason, "Detonation and Explosives Phenomena", USBurMines, Pittsburgh, ProgressRepts Nos **1 to 8** (July 1953 to June 1955), OrdnProj TB2-0001 74) *Ibid*, "Research Program on Detonation and Explosives Phenomena", ProgrRepts Nos **9 to 12** (July 1955 to Dec 1956), OrdnCorpsProject TA3-5101 75) M.A. Cook, *JChemPhys* **23**, 409-10 (1955) & CA **49**, 6607 (1955) (Mechanism of deton) 76) W.E. Deal Jr, "The Measurement of Chapman-Jouguet Pressure of Explosives" discussed in the 2ndONRSympDeton (1955) 77) Dunkle's Lecture at Picatinny Arsenal, 21 Nov 1955, p 3 (One-dimensional steady-state process and Rankine-Hugoniot equation) 78) *Ibid*, 13 Dec 1955, p 5 (Nature of shock waves); p 8 (Chapman-Jouguet point); pp 8-9 (Basic equations of deton); p 9 (Definition of deton process) 79) Ya.B. Zel'dovich & A.S. Kompaneets, "Teoriya Detonatsii", GosIzdatTekh-TeorLit, Moskva (1955) (Engl translation under the title "Theory of Detonation", published in 1960 by Academic Press, NY) 80) Anon, "Military Explosives", **TM9-1910** (1955), pp 37-40 (Deton theory) 81) G. Schweikert, *Explosivstoffe* **3**, 197-206 (1955); *Ibid* **4**, 10-14 (1956) (Theory of Detonation of Solid Explosives) 82) M.A. Cook et al, *TrFaradSoc* **52**, 369-84 (1956) & CA **50**, 14229 (1956) (Mechanism of deton) 83) K.K. Andreev, "Vzryv i Vzryvchatyiye Veshchestva" (Explosion and Explosive Substances), Voen-Izdat, Moskva (1956) 84) C.V. Bertsch, "Theories of Detonation and Burning", *PATR* **2268** (1956) (OrdProj TAI-5006) [The following topics are discussed: a) General energy equation b) Velocities relative to the deton zone c) Rankine-Hugoniot equation and curves d) Chapman-Jouguet hypothesis e) Solution for the C-J point and f) Covolume] 85) R.D. Cowan & W. Fickert, *JChemPhys* **24**, 932-39 (1956) & CA **50**, 11017 (1956) (Detonation props of solid expls; calcn with Kistia-kowsky-Wilson equation of state) 86) M.P. Murgai, *JChemPhys* **24**, 635 (1956) & CA **50**, 9078 (1956) (Extension of Comer equation of state to the more extreme regions of pressure obtd in the deton of condensed expls) [See also Section 3, DETONATION (AND EXPLOSION), EQUATIONS OF STATE IN] 86a) M.A. Cook, Paper No 25 and Note on Theory of "Free Surface Velocity", Discussion of the Faraday Society, Sept 20-21 (1956) (Informal discussion) (Listed as Refs 11 & 12 in Cook's book, p 89) 87) M.A. Cook et al, *JChemPhys* **24**, 60 (1956) and Cook (1958), Chap 6, p 125 (Geometrical theory) 88) M. Tailandier & G. Touzeau, "Déflagration et Détonation", Paper No 36 presented at the 9th International Conference of Directors of Safety in Mines Research, Bruxelles-Heerlen, Belgium (1956) (Engl translation OTIA No 3058) 88a) G.I. Pokrovskii & G.I. Fedorov, "Deystviye Udara i Vzryva v Deformiruyemykh Sredakh" (Action of Shock and Explosion in Deformable Media", *PromstroyIzdat*, Moskva (1957) 89) Clark & Hawley (1957), 293-94 (Detonation by W.H. Rinkenbach) and 369-72 (Explosives, Pre-explosion reactions, Explosive deflagration, Detonation and Explosion

- hazards by M.A. Cook) 90) K. Hino, *Kôgyô Kagaku Zasshi* **60**, 113-17 (1957) & *CA* **53**, 3693 (1959) (Ignition, combustion and detonation of expls) 91) T.C. Poulter, "A Report on Recent Basic Studies of Detonation of High Explosives", SRI Poulter Lab Rept **010-57** (1957). Presented at PicArns SAC (Scientific Advisory Council) 14th Meeting, Apr 1957, pp 83-92 (Conf) 92) C.F. Curtis & J.O. Hirschfelder, "Theory of Detonations", Univ of Wisconsin Navy Bu Ord Contract **NOrd-15884** (1957) 93) Dunkle's Syllabus (1957-58), 1-36 (Detonation phenomena, mathematical background); 37-60 (Initiation of shock waves; formulas & equations including: Riemann equation, p 43; Hugoniot relations in gases, p 44; Rankine-Hugoniot equation, p 45; Reynolds number, p 46), etc; 61-72 (Shock relationships and formulas); 73-98 (Shock wave interactions; formulas); 99-102 (The Rayleigh and Fanno lines); *Ibid* (1958); 159-61 (Thermal theory of initiation); 168-69 (One-dimensional steady-state process); 169-72 (The Chapman-Jouguet condition); 172-76 (The von Neumann spike); 181-84 (Equations of state and covolume); 184-87 (Polytropic law); 188, 210 & 212 (Curved front theory of Eyring); 191-94 (The Rayleigh transformation in detonation); 210-12 (Nozzle theory of H. Jones); 285-88 (The deton head model); 296 (Non-Chapman-Jouguet detonations); 355-72 (Performance predictions); 373-90 (Comparison of theory and experiment); 391-97 (Nuclear explns); 400-03 (Modifications forced in hydrodynamic theory) 94) N. Manson, *CR* **246**, 2860-62 (1958) & *CA* **52**, 19143 (1958) (A new relationship in the hydrodynamic theory of expl waves) 95) W.W. Wood & J.G. Kirkwood, *JChemPhys* **29**, 956 (1958) (Present status of deton theory) 95a) W. Fickett & W.W. Wood, *Phys of Fluids* **1**(6), 528-34 (Nov-Dec 1958) (A detonation-product equation of state obtained from hydrodynamic data) 96) Cook (1958), 1-4 (Definition of deton, expln & deflgn); 44-8 (Ideal deton); 48-50 (Nonideal deton); 50-7 (Transient and unstable deton waves); 57-60 (The jumping deton); 61-90 (Thermohydrodynamic theory of deton); 61-6 (Equation of state in deton of condensed expls); 66-8 (The Chapman-Jouguet postulate); 68-75 (The deton reaction zone in gases); 75-7 (Reaction zone in nonideal deton in gases); 77-9 (Reaction zone in condensed expls); 79-87 (Observations pertaining to spike theory); 87-9 (Heat pulse); 91-122 (Deton wave shape and density properties); 123-4 (Reaction rates in deton); 123 (Nozzle theory); 124 (Curved-front theory); 125-28 (Geometrical model); 143-71 (Phenomena accompanying deton); 172-205 (Initiation of expl deflagration and deton); 283-321 (Products of deton in expln and deton states); 322-52 (Shock waves in gaseous and condensed media); and 379-407 (Calculation of products of deton) 97) J.F. Roth, *Explosivstoffe* **1958**, 23-31 & 45-54, "Die elementare Ableitung der Strömungsgesetze der Detonation" (The Elemental Derivation of the Flow Laws of Detonation) (The paper includes among other topics: the hydrodynamic theory of deton, p 23; Hugoniot equation, p 46; and Abel equation, p 50) 98) B.P. Mullins & S.S. Penner, "Explosions, Detonations, Flammability, and Ignition", Pergamon Press, NY (1959); Reviewed *JInstPetrol* **48**, 62A (1962) (Part 1 comprises selected analytical studies on explns, detons, flammability limits, and ignition of gases, plus heterogeneous burning. Part 2 comprises experimental and theoretical studies of flammability, ignitability, and expln prevention) 99) F.A. Baum, K.P. Stanyukovich & B.I. Schekhter, "Fizika Vzryva" (Physics of Explosion), Fizmatgiz, Moskva (1959). The book includes among other topics: Definition of expln and classification of expln processes, pp 9-16; Theory of shock waves, which includes "shock adiabat" on p 190 (pp 182-224); Theory of deton waves (pp 225-27); Hugoniot curve for detonation waves (p 228); Hydrodynamic Theory of deton (p 226); Explosion in air (pp 555-663); Theory of point initiation of deton, called in Rus "Teoriya tochechnago vzryva" (pp 598-624); Theory of spherical expln (pp 624-40); Explosion in condensed medium (pp 664-81); Propagation of shock waves in water (pp 681-90); Some problems of theory of deton in liquids (pp 690-98); Propagation of waves in solids (pp 708-18); and Theory of deton in earth (pp 718-44) 100) J. Berger & J. Favier, *MP* **41**, 75-83 (1959) (Deton theories; Chapman-Jouguet characteristics for solid expls) 101) C.F. Curtiss et al, *JChemPhys* **30**, 470-92 (1959) (Theory of deton) 102) W.B. Garn, *JChemPhys* **30**, 819-22 (1959) (Data are reported which determine the unreacted Hugoniot curve for liquid

- TNT at an initial temp of 81°C and over pressure range 45 to 100 kilobars) 103) K.K. Andreev & A.F. Belyaev, "Teoriya Vzryvchatykh Veshchestv (Theory of Explosive Substances), Oborongiz, Moskva (1960) (It includes among other topics: Definition of explosion (pp 20-37); Theory of chain explns (pp 61-80); Burning to deton transition (pp 141-44); Theories of deton of Abel and Berthelot, (pp 222-23); Hydrodynamic theory of deton in gases (pp 223-43); and Hydrodynamic theory of deton in condensed expls, which includes on pp 249-50 description of Cook's theory (pp 244-62) 104) Ya.B. Zel'dovich & A.S. Kompaneets, "Theory of Detonation", Academic Press (1960), p 219. Translated from Russian book "Teoriya Detonatsii", Moskva (1955) (Z & K in reviewing Apin's papers pointed out that jets of the expln products interpenetrate the granules so that these burn in the atm of the products at a rate depending on their pressure. Consideration of the combstn of particles in random distribution, their interaction, and the motion of the gases "reduces to the requirement that the tangency condition in the expln products be satisfied". Thus the deton vel has the classical value which depends only on the initial state of the expl medium and the equation of state of the expln products) 105) F.C. Gibson, C.R. Summers & F.H. Scott, "Studies on Deflagration to Detonation in Propellants and Explosives", USBurMinesProgressReports from Jan 1959 to Sept 1959 and AnnualSummaryRept No 3769 covering the period from Jan 1959 to Dec 1959, Pittsburgh, Pa, ARPA (Advanced Research Projects Agency) Order Nos 44-59 & 44-61 106) Ibid, Progress Repts covering period Jan 1960 to Sept 1961 and Summary Rept No 3863 covering the period Jan 1960 to Dec 1961 107) Dunkle's Syllabus (1960-1961), Sessions 1-8 (Shock waves); Sessions 9-11 (Development of deton from deflagration); Sessions 12-13 (Stability and sensitivity of expls); Sessions 14-15 (Structure of the deton wave); Session 16 - was not published; Sessions 17-19 (Detonation in solid expls); Sessions 20-24 (Thermochemistry and energetics of deton); Session 25 (Measurement of deton pressure and of temp developed on deton); Session 26 was lost during typing 108) M.W. Evans & C.M. Ablow, ChemRevs 61, 129-78 (1961) & CA 55, 10891 (1961) (Detonation theories; a review with 312 refs) 108a) B. Belkovski & G. Dyakov, "Vzrivni Veshchestva: Teoriya, Khimia, Tekhnologia i Upotreba" (Explosive Substances: Theory, Chemistry, Technology and Use), Tekhnika, Sofia, Bulgaria (1962) 109a) EncyclBritannica 8(1963), 975-76 (Detonation and deflagration) 110) J. Herschkowitz, "The Chapman-Jouguet Plane for a Granular Explosive", PATM 1474(1964) (Based on the deton vel of a granular mixt of K perchlorate and powdered Al confined in a Lucite tube and an ideal deton velocity calcd by the Ruby computer, H. found that the C-J plane is ca 0.9 cm behind the plane at which the expln reaction begins) 111) W.H. Rinkenbach, formerly of PicArnsn, Private communication, Oct 1964) 112) F.J. Cheselske, "Investigations of the Mechanisms of Decomposition, Combustion and Detonation of Solids", Aerojet-General Corp, Final Rept 0372-01F, covering the period March 1964 thru Feb 1965, Contract AF 49(638)-851 112a) R.J. Wasley & J.F. O'Brien, "Low-Pressure Hugoniot of Solid Explosives", 4thONRSympDeton (1965), p 239 (Abstract only) 112b) N.L. Coleburn & T.P. Liddiard Jr, "The Unreacted Hugoniot Equations-of-State of Several Explosives", Ibid, p 240 [Abstract of paper, published in JChemPhys 44, 1929(1966) 112c) V.M. Boyle, R.L. Jameson & M. Sultanoff, "Determination of Shock Hugoniot for Several Condensed Explosives", Ibid, pp 241-47 113) T. Urbanski, "Chemistry and Technology of Explosives", Pergamon Press, NY, Vol 1 (1964); Vol 2 (1965) and Vol 3 (1967). Translated from Polish book published in 1953-1954, under the title "Chemia i Technologia Materialow Wybuchowych", Warczawa. Its Czech translation was published in Praha in 1958-1959, but there is no translation into Russian 113a) E.L. Lee & H.C. Hornig, "Equation of State of Detonation Product Gases", 12th-SympCombstn (1968) (Pub 1969), pp 493-99 113b) S.J. Jacobs, "On the Equation of State for Detonation Products of High Density", Ibid, pp 501-10 113c) S.R. Brinkley Jr, "Temperature Explicit Equation of State of the Products of Condensed Explosives", Ibid, Paper 49 (Abstracts only) 113d) R.W. Woolfolk & A.B. Amster, "Low Velocity Detonations: Some Experimental Studies and

Their Interpretation'', Ibid, pp 731-39
114) Dunkle, private communication, March 1969

Detonation (Explosion, Deflagration and Decomposition), Thermal Theories and Thermochemistry of. Cook (Ref 8) discusses both isothermal and adiabatic decompositions

Under *isothermal decomposition*, he states that it is difficult to maintain isothermal conditions in such strongly exothermic reactions as are involved in the thermal decomposition of explosives owing to their tendency for self-heating. One is also concerned with the elimination (or minimization) of temperature transients in bringing the sample to the predetermined temp of the experiment. After a brief description of experiments of A.J.B. Robertson and of A.D. Yoffe, conducted in England, the quartz spring apparatus designed by M.A. Cook & M.T. Abegg, IEC 48, 1090 (1956), is very briefly described and its schematic diagram is shown in Fig 8.1a, p 175. In this method a small sample of expl, suspended on a thin chain attached to a quartz spring is heated in the furnace shown in Fig 8.1b at a predetermined temperature registered by a thermocouple, and its loss of weight vs time is determined. The curves log w vs time are given on pp 176-77 for AN, EDNA & PETN. This method is not applicable to expls in which weight loss is the result solely of decomposition and not merely of vaporization or both vaporization and decomposition. It cannot be used for TNT because at the temperatures at which it could be applied vaporization and decomposition take place simultaneously.

If decomposition proceeds at the same rate over entire range until practically no sample remains (like with AN), it is said that the explosive exhibits (ideal) first-order decomposition, and that no autocatalyzation takes place as in the decompn of PETN, Tetryl or RDX. EDNA followed the first-order decomposition law only until ca 5% of the expl had decomposed. This was followed by *autostabilization*, the term applied here on the supposition that one of the condensed decompn products of EDNA which accumulated in the sample apparently tended to stabilize it, thus slowing down the decompn. After ca 10% of the expl had decomposed, however, autocatalysis developed

The (first-order) isothermal decomposition rate constant of expls can be expressed as:

$$k'(T) = Ae^{-\Delta E/RT}, \quad (8.12)$$

where A and ΔE are the Arrhenius constants.

In the absolute-reaction rate form this is written as:

$$k'(T) = A' Te^{-\Delta H^\ddagger/RT}, \quad (8.13)$$

where: $A' = (k/h)e^{\Delta S^\ddagger/R}$; k = Boltzmann's constant, h = Planck's constant; ΔS^\ddagger = entropy of activation; ΔH^\ddagger = heat of activation

The values of A, A', and ΔH^\ddagger (or ΔE) detd by isothermal decompn method are listed in Table 8.1, of which we give the following examples:

Table
Specific Rate Constants for Assumed
First-Order Isothermal Decomposition

| Explosive | log A | log A' | ΔH^\ddagger kcal/mol | Temp Range, °C |
|----------------|-------|--------|---------------------------------|-------------------|
| AN | 12.3 | 9.6 | 38.3 | 217-267 |
| EDNA (initial) | 11.1 | 8.5 | 30.8 | 144-164 |
| EDNA (autocat) | 31.5 | 28.9 | 71.7 | 144-164 |
| Tetryl | 12.9 | 10.3 | 34.9 | 132-164 |
| PETN (autocat) | 15.2 | 12.6 | 38.6 | 137-157 |
| RDX (autocat) | 18.5 | — | 47.5 | 213-299 |
| NG (autocat) | 19.2 | — | 45.0 | 125-150 |

The isothermal method for such expls as PETN, RDX, NG and Tetryl is complicated by autocatalysis to such an extent that one cannot determine the intrinsic (pure explosive) decompn rate from the $\log w$ vs t curves and their change with temperature. Hence, the results obt'd by the adiabatic (sensitivity) methods may be more reliable from this viewpoint (Ref 8, p 177)

Under *adiabatic decomposition*, Cook (Ref 8, p 178) states that F.P. Bowden et al; E.K. Rideal & A.J.B. Robertson; J.L. Copp, A. Yoffe and their coworkers (See Refs listed on pp 42-3 of Cook's book) have made outstanding contributions to the knowledge of the sensitiveness of explosives. Their preliminary investigation showed that all types of sensitivity measurements may be understood in terms of *thermal decomposition* and laws of adiabatic decomposition. Moreover, they developed A & B data for equation:

$$\log_{10} \tau = A/T_0 + B \quad (8.9)$$

that may be related directly to the A^\ddagger and ΔH^\ddagger data of eq (8.13), listed above. Symbols in eq (8.9) signify: τ =induction period in initiation of expl;

$$A = \Delta H^\ddagger / 4.567 \quad \text{and} \quad (8.10)$$

$$B = \log_{10} \left(C e^{-\Delta S^\ddagger / R} R T_0 / Q k f \Delta H^\ddagger \right) \quad (8.11)$$

where: C=heat capacity; h=Planck's constant, S^\ddagger =entropy of activation; Q=heat of expln; k=Boltzmann's constant, and f=function

In addition, the detailed considerations of the above listed investigators are of great practical importance in understanding and coping with explosion hazards. It seems clear from their studies that the sensitivity problem is contained wholly within the framework of the heat-balance equations:

$$F + Q = H \quad (8.1)$$

where: F=heat loss; G=accumulation of heat in the explosive and H=chemical energy generated by the decompn of the expl

Eq (8.1) is derived by simplification of eq (2.11) listed on p 40 of Ref 8

Cook remarked that the fundamental principles of the thermal explosion (or autoignition) were established earlier than by the above listed investigators. One of them, T.H. van't Hoff, published a paper on this subject as early as 1876, while many (especially Russians) published works in 1930. These earlier scientists in-

cluded: Semenov (Ref 1), Frank-Kamenetskii (Ref 1e), Todes (Ref 1c), Belyaev (Ref 1g), Andreev (Ref 2), Garner, (Ref 1a), Rice (Ref 1b) and others. The quantitative theory of thermal explosion was originally developed for gaseous systems, but its application to condensed explosives was, accordg to Maček, first described by Rideal & Robertson (Ref 3a)

In Appendix II of Cook's book entitled "Calculations of Products of Detonation" is described on pp 386-90 the *thermochemistry of explosions*

A comprehensive description of the thermal decomposition of explosives, including the *thermal explosion theory* is given by Maček (Ref 13). His discussion assumes a homogeneous isotropic solid undergoing a first-order exothermic chemical reaction and exchanging heat with chemically inert surroundings. It is also assumed that diffusion and convection within the fuel is negligible (See Note); that the thermal conductivity and the heat capacity of the explosive are constant; that the amt of reactant consumed prior to thermal expln is negligible; and finally that there is no autocatalysis of chemical reaction

Note: The amt of expl reacting during the thermal induction period is ca 5-10%

The aim of the *thermal explosion theory* is to obtain knowledge of the temperature of the system as a function of both time and location. This can be calcd from the equation:

$$c \rho \frac{\partial T}{\partial t} = \lambda \nabla^2 T + q \quad (1)$$

where c=specific heat (cal/degree/gm); λ =thermal conductivity (cal/cm/sec/degree); ρ =density (g/cc); $\nabla^2 T$ =second partial derivative of temperature with respect to distance; and q=rate of heat evolution (cal/cm/sec)

Eq (1) states that there is a balance of the heat evolved in the chemical reaction, the heat conducted from the site of the reaction and the increase in the temp of the system. It is the term q which both determines the expl props of a reactant and is the source of mathematical obstacles to finding the soln of eq (1). This is so because the peculiar nature of expl reaction requires a mathematical expression for q which will allow a very rapid change of reaction rate within a narrow temp range. The conventional two-constant Arrhenius term satisfies the requirement, providing the exothermicity of the

reaction, Q , is sufficiently high:

$$q = \rho Q Z e^{-E_a/RT} \quad (2)$$

where Q = heat of reaction; Z = frequency factor of a homogeneous first-order reaction and E_a = activation energy

The exponential dependence of the evolution of heat upon temp, besides rendering eq (1) nonlinear and hence difficult to solve, accounts for the existence of concepts such as ignition, ignition temp, induction period, limits of inflammability and, indeed, of the concept of "explosion" itself, which can be defined no more rigorously than by the requirement that the reaction rate become sufficiently high. This fundamental point is implied in every theoretical treatment of thermal expln, but it has been brought out explicitly in Russian scientific literature (Refs 5, 6, 9, 11 & 14). In particular Frank-Kamenetskii has shown (Ref 5) that the quantitative requirement for a homogeneous thermal reaction to be explosive is $E_a \gg RT$. Since eq (1), being nonlinear, cannot be solved in a general manner, the solution consists of a series of approximations, such as described by Frank-Kamenetskii (Ref 5) and later discussed critically by Gray & Harper (Ref 10) (Ref 13, p 45)

Further in his paper, Maček describes on pp 45-7, the "stationary approximation", i.e., the case in which the space distribution of temperature does not vary with time, $\partial T/\partial t = 0$. Here the works of Frank-Kamenetskii (Ref 5), Semenov (Ref 1), Gray & Harper (Ref 10) and others are applied and their implications are discussed

In the "nonstationary approximation" described by Maček on p 47 are discussed the works of Frank-Kamenetskii, Semenov & Gray & Harper

Under the heading "General Case", Maček states (p 47) that in order to solve eq (1) without approximations subject to specific boundary conditions, one has to resort to numerical procedures. G.B. Cook (Refs 6a & 7a) treated two problems by means of calcs with digital computers. First is the case of a slab of solid expl, one face of which was in contact with a constant-temp bath. In the 2nd case the expl was subjected to a time-dependent heat pulse. In both cases the time to ignition and the critical condition for ignition are given as

functions of physical parameters of the system. A calcn similar to the first case has been done by Zinn & Mader (Ref 11a) for a semi-infinite slab, an infinite cylinder, and a sphere, and compared with experimental data for the cylindrical shape. In spite of the fact that the mathematical model neglects fusion (the expln temp is usually above mp of the expl), agreement betw the calcd and the exptl values is reasonably good

Under the heading "Rates of Reactions of Explosives", Maček states (p 47) that despite a fair measure of attention, the "chemical kinetics" of the reactions of expls has defied a unified explanation, perhaps more than any other phase of the sensitivity problem. This is unfortunate because *thermal explosion theory*, described above, which is fundamental to all expl phenomena, can become quantitative only when the necessary experimental parameters are furnished. Some examples of calcd parameters are given on p 48 in review by Maček. They include E_a (activation energy), which for HE's is betw 35 and 50 kcal/mol and Z (frequency factor of a homogeneous first-order reaction), which is betw 10^{13}sec^{-1} to 10^{20}sec^{-1} . Under the headings "Isothermal Kinetics" and "Adiabatic Kinetics" (pp 48-9) are treated the subjects entitled by Cook (Ref 8) as "Isothermal Decomposition" and "Adiabatic Decomposition"

Maček also discusses "Surface Burning" (pp 49-50). This subject was discussed in Vol 2 of Encycl, pp B343 to B356
 Refs: 1) N.N. Semenov, ZPhysik **48**, 571 (1928) and book "Chemical Kinetics and Chain Reactions, Oxford Univ Press, London (1935)
 1a) W.E. Garner & A.S. Gomm, JCS **134**, 223 (1931) 1b) O.K. Rice et al, JACS **57**, 1044 & 2212 (1935) 1c) O.M. Todes, ZhFizKhim **4**, 71 (1933); Ibid **13**, 868 & 1594 (1939); Ibid **14**, 1026 & 1447 (1940) 1d) O.M. Todes, ActaPhysicochim (Russia), **5**, 785 (1936)
 1e) D.A. Frank-Kamenetskii, ActaPhysicochim or ZhFizKhimii (Russia), **10**, 365-70 (1939) (In English); Ibid, **13**, 738-55 (1939); Ibid, **16**, 357-61 (1942); Ibid **20**, 729-36 (1943); Chemical Abstracts **33**, 6049 (1939); **34**, 7607 (1940); **37**, 3273 (1943) & **40**, 4217 (1946) (Mathematical theory of thermal explosion, called the "stationary theory of thermal explosion")
 1f) D.A. Frank-Kamenetskii, ZhFizKhim **20**, 1301 (1945) 1g) A.F. Belyaev, DoklAkadN

50, 303(1945) & JPhysChem **20**, 613(1946)
 2) K.K. Andreev, DoklAkadN **54**, 39-42(1946)
 (Influence of burning velocity on the character
 of the thermal explosion of liquid explosives)
 3) A.D. Little, Inc, "Report on Study of Pure
 Explosive Compounds, II. Correlation of
 Thermal Quantities with Explosive Properties",
 Contract **W-19-020-ORD-6436** (1947) 3a) E.K.
 Rideal & A.J.B. Robertson, PrRoySoc **195A**,
 135(1948) 4) P.L. Chambré, JChemPhys
20, 1795-97(1952) (The solution of the
 Poisson-Boltzmann equation with the appli-
 cation to thermal explosions) 5) D.A. Frank-
 Kamenetskii, "Diffusion and Heat Exchange in
 Chemical Kinetics," pp 202-66, Princeton Univ-
 Press, Princeton, NJ (1955) (Quoted from
 Maček's paper) 6) L.N. Khitrin, "Fizika
 Goreniya i Vzryva" (Physics of Combustion
 and Explosion), IzdMGU, Moscow (1957)
 6a) G.B. Cook, 6thSympCombstn (1957), p
 626 7) Dunkle's Syllabus (1957-1958),
 135-49 (Thermal decomposition in solids);
 231-42 (Thermochemistry and energetics of
 detonation) 7a) G.B. Cook, PrRoySoc **246A**,
 154(1958) 8) Cook (1958), 174-87 (Thermal
 decomposition in solids which includes iso-
 thermal and adiabatic decompositions); 386-91
 (Thermochemistry of detonation and explosion)
 9) Baum, Stanyukovich & Shekhter (1959),
 81-108 (Thermochemistry of explosives)
 10) P. Gray & M.J. Harper, "Thermal Explo-
 sions", Part I - "Induction Periods and Tem-
 perature Changes Before Spontaneous Ignition",
 TrFaradSoc **55**, 581-90(1959) 11) Andreev
 & Belyaev (1960), 49-56 (Thermal explosion
 in gases); 56-61 (Thermal expln in solids)
 11a) J. Zinn & C.L. Mader, JApplPhys **31**, 323
 (1960) 12) Dunkle' Syllabus (1960-1961)
 (Spontaneous detonation thru self-heating)
 13) A. Maček, ChemRevs **62**, 44-47 (1962)
 (Thermal decomposition of explosives includ-
 ing a thermal explosion theory) 14) A.M.
 Grishin & O.M. Todes, DoklAkadN **151**(2),
 366-68 (1963) & CA **59**, 12585 (1963) (Thermal
 explosion with heat transfer by convection and
 conduction) 15) P.G. Ashmore & T.A.B.
 Wesley, "A Test of Thermal-Ignition Theory
 in Autocatalytic Reactions", 10thSympCombstn
 (1965), pp 217-226

*Detonation, Three-Legged Table Sensitivity
 Test.* See under DETONATION (AND EXPLO-
 SION) BY INFLUENCE, Section 6

Detonation, Threshold Ignition Pressure in.

Cook (1958), p 198 ff, reports that the most
 satisfactory index for ignition-nonignition is
 the min or threshold pressure for ignition. The
 threshold pressure, designated p_1^0 , is defined
 as the min initial pressure reqd to produce
 consistent ignitions of a given proplnt by a
 particular detonating gas of given compn. The
 quantity p_1^0 has the advantage of being directly
 observable. A more fundamental index is the
 threshold detonation pressure, p_2^0 , or the
 threshold explosion pressure, p_3^0 . However,
 since p_2^0 & p_3^0 may be computed from p_1^0 thru
 hydrodynamic theory, and since p_2^0 & p_3^0 are not
 directly observable, p_1^0 is considered quite as
 reliable an index as p_2^0 or p_3^0 .

Cook's measurements of p_1^0 , τ =the real time
 lag to start decompn & erode a given thickness
 of proplnt, and τ_p =time lag based on the initial
 appearance of a stable flame were conducted in
 a heavy-walled, steel shot tube 1 inch in diam.
 The shot tube was 90 cm long and contd ioniza-
 tion-gap stages ahead of the proplnt to be cer-
 tain that a constant vel was obtd at least 50 cm
 before contact with the proplnt. The proplnts
 studied were homogeneous double-based rocket
 proplnts contg NC (approx 50%), NG (30-40%),
 and varying percentages of plasticizers, stabi-
 lizers & other additives. Test samples were
 smooth 2.5 cm diam by 3 mm thick wafers mount-
 ed in the tube opposite the point of initiation.
 Ignition of the gas used to initiate the proplnt
 was effected by discharge of a 1 μ f capacitor
 at 4400 volts thru a high-pressure spark plug.
 Detonation & predetonation flame velocities
 were measured by means of the pin-oscillo-
 graph technique

Cook's FIG 8.19 shows p_1^0 vs compn curves
 for proplnts (designated as A, B, C & D) using
 H_2 - O_2 igniters. The curves show large p_1^0
 values for H_2 -rich igniters and small p_1^0 values
 for O_2 -rich igniters. It was also found that
 deton was produced only in igniter compn range
 H_2/O_2 from 0.4-5.0 and the failure of p_1^0 to
 increase sharply with H_2/O_2 from 5-7 indicates
 that the deflagration flame, although cooler &

less intense than the detonation flame, was as effective as the detonating gases in igniting the propellants

See also Detonation (and Explosion), Development (Transition) from Burning (Combustion)

tion) or Deflagration, Section 2; and Detonation (and Explosion) Initiation (Birth), and Propagation (Growth or Spread) in Explosive Substances Section 7

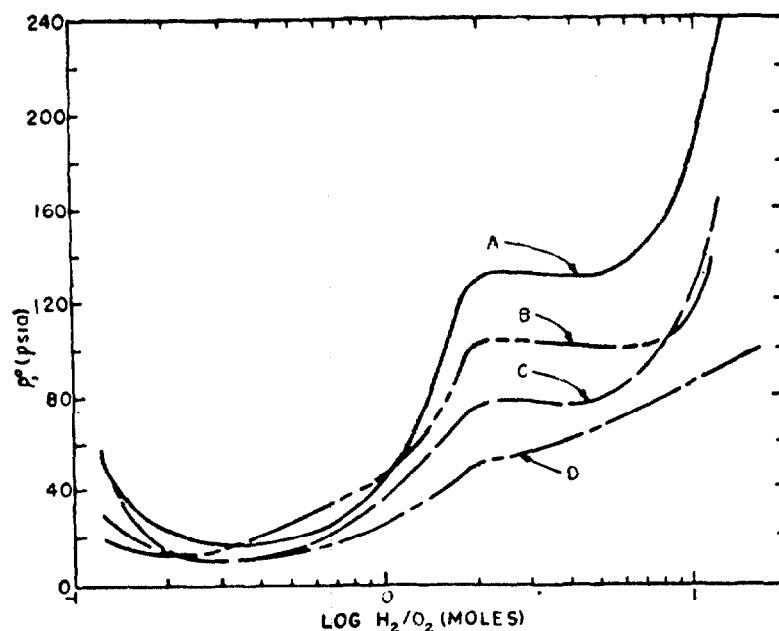

Figure 8.19. Threshold ignition pressure p_i^0 versus H_2/O_2 ratio for ignition of propellants A, B, C, and D

Detonation, Threshold Velocities V_c (Theoretical) for Impact Explosions of Massive Targets in.

The critical striking velocity (V_c) for impact explosions of the target is that vel at which the heat developed by inelastic collision is equal to the heat of vaporization. For single-particle impact, the equation:

$$V/U = 1 + (\rho/\lambda\rho_j)^{1/2}$$

where V = velocity of jet, U = velocity of penetration of target, ρ = density of target, ρ_j = density of jet material, and λ = a factor related to the nature of the jet is 1 when it is completely fluid, should apply since the flow in the target and projectile will be essentially nonviscous

The impact-explosion velocity threshold (V_{ct}) may be obtained by the equation:

$$V_{ct} = (8h_c)^{1/4} (\rho^{1/2} + \rho_j^{1/2}) / (\beta\rho_j^2\rho)^{1/4}$$

where h_c = specific heat of vaporization of the

target, and β = compressibility factor. When target & projectile are of the same compn, the above equation reduces to:

$$V_{ct} = 2(8h_c/\beta\rho)^{1/4}$$

Data computed from this theory of target impact explns for metals show that only Pb & Zn should be exploded by jets from 50/50 Pentolite & similar shaped chgs. Pb & "Zamak" alloy (largely Zn) show definite target mass losses due to impact explns which provides evidence for some validity to the above theory of target impact expln

Ref: Cook (1958), pp 260-61

Detonation, Transducers' Application in Phenomena of. See Refs 74 & 77 under DETONATION (AND EXPLOSION), EXPERIMENTAL PROCEDURES IN

Detonation (and Explosion), Transfer. The term "detonation transfer", used by R.H.F. Stresau in the paper entitled: "Size Factors in Detonation Transfer", presented at the 4th ONRSympDeton (1965), pp 442-48, means the same phenomenon as described here under DETONATION (AND EXPLOSION), BY INFLUENCE OR SYMPATHETIC DETONATION, Section 6

Detonation Transients and Unstable Detonation Processes. Allen et al (Ref 1) made detonation velocity vs chge length measurements on RDX (-65+100 mesh), fine grained TNT (-35-150); coarse, low-density TNT (-8+10); 50/50 fine-coarse TNT, cast TNT, low-density mixts of 80/20 TNT/AN, and mixts of 90/10 AN/RDX. Deton velocities were measured by a rotating mirror streak camera and by the pin oscillograph technique, in most cases simultaneously

Their exptl data showed six different types of velocity transients:

- 1) *Single sharp or discontinuous transition from an initial low, but constant, velocity regime to the normal high velocity regime.* This was illustrated by Tetryl & EDNA, previously observed by other investigators, and similar to the dual vel observed in Gelatin Dynamite, Straight Dynamite & pure NG
- 2) *Dual discontinuous transitions from constant or nearly constant velocity regimes.* This type of transient was observed in cast TNT, fine grained TNT, and in coarse grained TNT (not previously observed)
- 3) *Decaying velocity.* A commonly observed type of transient associated with overboosting and/or with fading deton, but seldom over such a long distance as observed in this study with coarse TNT
- 4) *Smoothly accelerating velocity-transient stabilizing at $L_D/d = 3(+1)$.* L_D = end of vel transient and beginning of stable vel, d = diameter in cm. This type of transient, predicted by the deton head model and characteristic of non-ideal deton in point initiated chges, was observed in low density 80/20 AN/TNT, 90/10 AN/RDX mixts, and in 50/50 cast Amatol
- 5) *Combination of type 2) and type 4).* This type of transient was observed in low density 50/50 fine-coarse TNT and in low density 80/20 AN/TNT in the smaller diam chge

6) *Smoothly accelerating velocity transient stabilizing in less than 3 charge diameters.* This type, predicted by the deton head model, was observed in pure RDX. It should apply to expls in chge diameters immediately above the min chge diam for ideal deton

The study of transients should add considerably to the understanding of the mechanism of initiation & propagation of deton. Since certain theories predict particular types of transients, their existence or absence should be of value in evaluating these theories. Velocity transients should also be related to the rate of chem reaction in deton. Perhaps of most significance is the influence of vel transients on the performance of expls in applications where the ratio of length (L) to diam (d) of chge is of great importance, such as in shaped charge & other applications of end impulse

See also Refs 2 to 5 for addnl info

Refs: H.J. Allen, M.A. Cook & D.H. Pack, "Transients in Detonation", Univ of Utah, Inst of Study of Rate Processes, TechRept No L, April 1956 2) Dunkle's Syllabus (1957-1958), pp 284-85 (A brief discussion on detonation transients) 3) Cook (1958), 50-9 (Transient and unstable detonation waves); 59 (Recapitulation of observed transient phenomena); 128, Fig. 6.2 (Influence of reaction zone length on transient and steady-state velocities); 140-41 (Transient and anomalous wave propagation); 318 (It is stated that the AN-coarse TNT-water slurries all detonate in the *transient detonation region* by the *jumping detonation reaction*) 4) J. Brossard, CRCongrNatlSocSavantes, SectSci 87, 339-51 (1962) & CA 61, 14456 (1964) (A theory for the double discontinuity of unstable detons in which it is assumed that the combustion wave closely follows the shock wave) 5) L.N. Gal'perin & K.K. Shvedov, ZhFizKhim 37(5), 1182-86 (1963) & CA 59, 3711 (1963) (Method and apparatus for investigating transient detonation processes); Engl translation in RussJPhysChem 37, 631-34 (1963)

Detonation (and Explosion), Transition from Deflagration (or Combustion) to. See Detonation (and Explosion), Development (Transition) from Burning (Combustion) or Deflagration, Section 2 and A. Maček, ChemRevs 62, 50-52 (1962) (Transition from deflagration to detonation)

Detonation, Transition from Shock to. At the beginning of the report (Ref 1) Jacobs et al give a list of refs and also a résumé of work performed after WWII on the *transition from shock to detonation*. They state that in the majority of these refs the build-up of detonation has been attributed to an initiation of chem reaction by either a uniform or a localized temp rise associated with adiabatic compression followed by growth determined by the continued speed-up of the reaction once it has begun. An alternate hypothesis which postulates the development of high thermal conductivity behind the shock leading to a heat pulse has been proposed. The latter hypothesis makes no clear distinction between the behavior of liquids and polycrystalline solids. The former, more prevalent, viewpoint supplies a framework for explaining differences in behavior: a) betw solids and liquids; b) betw solids formed by different techniques (such as by casting or pressing); c) due to geometric configurations of the medium under study; and d) due to spatial and temporal distribution of pressure and flow

The transition to detonation in a liquid expl, when a plane step shock is induced in it, appears to be the simplest to explain in its physical aspect. Here the temp rise in a homogeneous compression seems sufficient to account for the build-up to detonation. The meager evidence from the experiments on single crystals, carried out in such a way that rarefaction effects may be considered negligible, are in accord with this model. The response of polycrystalline solid expls to the entering shock is not as clear as in the case of liq expls. Solid expls are formed into a mass which contains numerous crystal entities, and both macroscopic and microscopic voids. When initiated by plane shocks of low shock amplitude, the dependence of build-up time on crystal size and void content makes it fairly evident that the low temp rise calcd for a homogeneous compression cannot account for the observed transition. Thus a hot-spot mechanism of the type suggested by F.P. Bowden et al is required. The confirmation of early work by C. Winning and W.R. Marlow, who reported that induced shocks, with pressures as low as 20 kilobars, would cause transition-to-detonation, has established important support of a mechanism centered around a relatively small number of initiation states. Studies to

show how a deton develops when both the physical state of the expl and the shock amplitude are varied are beginning to lead to a better understanding of the nature, magnitude and behavior of the initiation sites

The shock-to-detonation transition has been studied at the Naval Ordnance Laboratory by the use of the plane-wave system arranged in such a way as to make it possible to follow continuously the wave front within the shocked sample. The experiments made it possible to simultaneously establish the initial pressure in the shock and to observe the growth-to-detonation as it develops. The observations were made on a wedge-shaped test sample, the wedge permitting observations without grossly affecting the one-dimensional flow of the region of interest. This is equivalent to the observation of growth within an explosive charge of much larger dimensions. Thus, the results appear to agree reasonably well with shock-initiation work on long cylinders of cross-sectional area comparable to the area of the face of the test wedge, provided: a) the observations in the cylinder are made in the region of its axis (not on the exterior surface) and b) the pressure-time histories of the entering shock are similar. The results of these experiments were in accord with the explanation that growth-to-detonation in polycrystalline solids is the result of pressure build-up from temperature-triggered chem reaction spreading from localized sites

Experimental Procedure of NOL. A schematic view of set-up for generating 20 to 180 kilobar plane shocks in the test sample is shown in FIG 1. Here the 11-cm diam plane wave generator developed a wave that was flat to 0.3 mm over a diam of 9 cm. A slab of expl, 12.5 x 12.5 x 2.5 cm, was placed betw the generator and a 20-cm diam disc of inert barrier, or shock attenuator. A sample of expl in the form of a 25° wedge (apex angle 90°) was then placed on the opposite face of the attenuator. A thin film of silicone grease was placed betw the attenuator and the test wedge to minimize the possibility of accidentally causing a hot-spot by a small amt of entrapped gas in the region. In general, the test wedges had faces 3.2 x 3.2 cm and were 1.4 cm high, but for the less sensitive expls, or where very low amplitudes were to be used, larger wedges, such as 5 x 5 cm at an angle of 30°, were employed

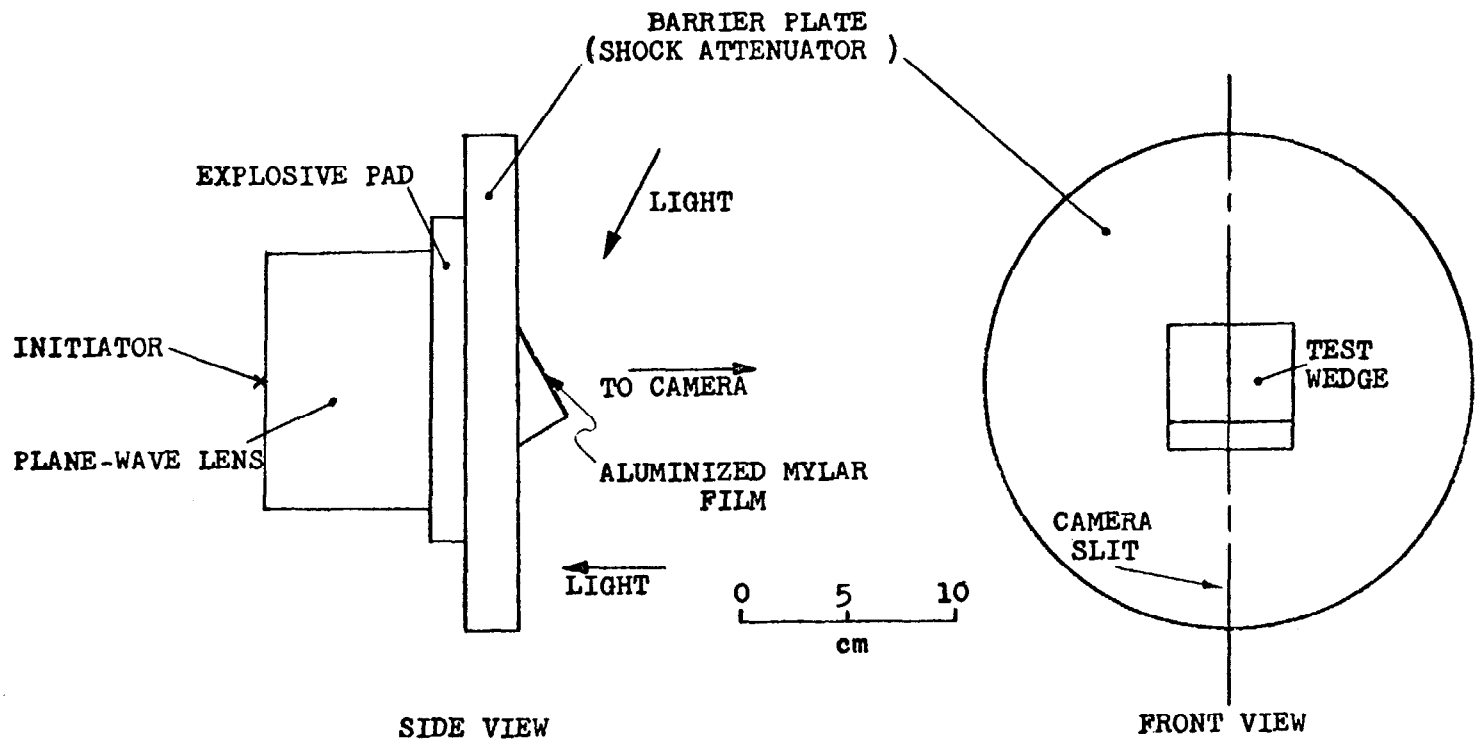

FIG 1 WEDGE-TEST ARRANGEMENT

The phase vel of shock arrival along the wedge free surface was detd with a smear camera having a writing speed of 3.8mm/ μ sec. The arrival of the wave was recorded by the camera by using an aluminized Mylar film on the surface of the specimen and reflecting light from an electrically-exploded wire confined in a glass capillary

Experiments on the initiation of deton in cast and pressed expl (TNT and various Cyclotols) were conducted by subjecting expls to plane mechanical shock introduced at a plane surface. Shock amplitudes ranging from 30 to 120 kilobars in the expl were generated by using plane wave lenses with various combinations of donor expls and barrier compns (such as Plexiglas, Naval brass or Lucite) and geometry. The shock velocity was obtd in each sample as a function of distance of travel into the wedge-shaped specimen from distance-time records obtd with a smear camera. The resultant curves for cast expls were found to be quite different from those for pressed expls. Furthermore, cast TNT exhibited a result anomalous to other cast expls. In the cast chges the initial wave in the shocked sample had the character of a *non-reactive shock*. The initial wave velocities in these chges have been used to compute the peak pressures behind these initial shocks. The build-up to deton has been found to be sensitive to the particle size in two 75/25-Cyclotols (RDX 75 & TNT 25%) of the same density, but with different particle size of RDX crysts. The build-up to deton has further been found to occur more rapidly in pressed than in cast chges of the same compn and density. These observations lead to the conclusion that in the range of initial shock pressures, the initiation takes place at localized centers from which the reaction spreads. These centers, named by Bowden "hot spots" must be present behind the shock to explain the rapidity with which the deton is established

Further work on shock-to detonation is required, but the results obtd so far at the lower shock amplitudes when compared to the results by NOL Gap Test [See Refs 47a & 58 under Detonation (and Explosion), Experimental Procedures, Section 4] lend support to the idea that peak pressure and pressure history in the shocked elements of expls are far more important than wave shape in determining the

time for transition to detonation (Ref 1) (See also Refs 3, 4 & 5)

Kendrew & Whitbread (Ref 2) detd the transition from shock wave to detonation in 60/40-RDX/TNT

Refs: 1) S.J. Jacobs et al, "The Shock-to-Detonation Transition in Solid Explosives", NOLTR **62-197**(1960) (32 refs) 2) E.R. Kendrew & E.G. Whitbread, 3rdONRSympDeton (1960), 574-83 3) M.W. Evans & C.M. Ablow, "Theories of Detonation", ChemRevs **61**, 167ff (1960) 4) A. Maček, "Sensitivity of Explosives" ChemRevs **62**, 53ff (1961) 5) S.J. Jacobs & T.P. Liddiard Jr, "The Shock-to-Detonation Transition in Solid Explosives", 9thSympCombstn (1963), 517-26

Detonation, Transition of. The term "transition of detonation" has been used by Evans to describe the transfer of detonation from one expl to another, in particular when the expls differed widely in deton velocities. In experiments described, two cylindrical sticks were placed end to end in good contact. These experiments differ from sympathetic detonation where two expls are placed at a distance (gap) from each other and not in contact as in transition

When an expl of deton velocity ca 8000m/sec was detonated in contact with an expl of 5000 m/sec, the velocity of the first expl was "carried over" into the second expl for a distance of less than a few mm from the boundary. The same effect was shown when the transition was from the low component to the high. This result was, however, not obtd if, for example, the second component was loosely packed and therefore of low density. In this case the transition in velocity was gradual and took several centimeters to reach a characteristic steady velocity

The distance at which transition takes place is called "carry-over distance". Its method of determination by means of the rapid photographic camera developed in 1944 by RRL (Road Research Lab) is described in Ref and the results of tests are shown in Figs 7 to 13 of paper. See previous item

Ref: W.M. Evans, "Some Characteristics of Detonation", PrRoySoc **204A**, pp 15-17 (1950) (Transition of detonation)

Detonation (and Explosion), Transmission of. Same as Detonation (and Explosion), Propagation of

Detonation, Triple Point, Transmission of. See Vol 2, p B182-L and Fig on p B183

Detonation and Two-Phase Flow is discussed at ARS Propellants, Combustion and Liquid Rocket Conference in 1961. Published by Academic Press, NY (1962)

Detonation, Type 1- and Type 2-Impact Tests in. See Ref 67 under DETONATION (AND EXPLOSION), EXPERIMENTAL PROCEDURES, Section 4

Detonation (and Explosion), Underwater. The formation & propagation of underwater shock waves generated by HE's are discussed in detail by Cole (Ref 3). Underwater expl effects

are more complicated than those occurring in air, underground, and other media. For a given expl, the underwater effects vary directly with the wt of chge and presumably with the total energy. Cole (Ref 3) gives as the relationship between shockwave energy & chge wt

$$E_s = kW^{1/3} \left(\frac{W^{1/3}}{R} \right)^\delta$$

where E_s = energy flux density, W = wt of chge in lbs, R = distance from chge in ft, and k & δ are constants which are specific for each expl. The equation shows direct proportionality between shockwave energy & wt of the expl. It also indicates that the fraction of the total energy in the shockwave at a given point is constant as the chge wt varies

Donna Price (Ref 10) tabulated the underwater performance data, as well as the estimated energies of deton for various expls

Underwater Performance Data for Various Explosives

| Explosive | Equivalent Weight Relative To Pentolite | | Indices of Overall Performance | | Calcd Heat of Detonation cal/g |
|----------------|---|--------|--------------------------------|-------------------|--------------------------------|
| | Shockwave | Bubble | Product | Sum | |
| | E_s | E_b | $I_p = E_s \cdot E_b$ | $I_s = E_s + E_b$ | |
| TNETB | 1.18 | 1.16 | 1.37 | 2.34 | 1446 |
| PETN | 1.15 | 1.13 | 1.30 | 2.28 | 1416 |
| RDX | 1.10 | 1.02 | 1.12 | 2.12 | 1228 |
| HMX | 1.11 | 1.06 | 1.18 | 2.17 | 1222 |
| Tetryl | 1.00 | 0.98 | 0.98 | 1.98 | 1047 |
| TNT | 0.87 | 0.96 | 0.84 | 1.83 | 984 |
| Expl D | 0.80 | 0.87 | 0.70 | 1.67 | 761 |
| 75/25 Cyclotol | 1.04 | 1.01 | 1.05 | 2.05 | 1167 |
| 60/40 Cyclotol | 1.02 | 1.00 | 1.02 | 2.02 | 1130 |

Comparison of the measured shockwave energy with the deton energy shows a rough linear relationship, but the curves do not extrapolate to the origin, i.e., direct proportionality does not exist. This indicates that the fraction of the total energy going into the shock wave varies from expl to expl. The dependence of the relative bubble energy on the total energy is very similar to the shockwave relation; roughly linear but not a direct proportionality. The two arbitrary indices of overall performance correlate with the deton energy and both have been used successfully for empirical predictions

Methods of measuring underwater shock waves by crusher gauges, diaphragm gauges & piezoelectric gauges are thoroughly described by Cole (Ref 3) in Chapter 7. Cook (Ref 7) describes the use of a 16- to 64-frame/sec camera to measure the free surface vel produced by a shock wave at the surface, and the determination of the underwater pressure-distance curve for TNT

[See also the Refs listed below and Blast Effects in Water (Underwater Blast) in Vol 2 of Encycl, p B183]

Refs: 1) J.G. Kirkwood & E.W. Montroll, "The Pressure Wave Produced by an Underwater Explosion", OSRD Rept 676(1942); PB32183
 2) Division 2 NDRC, Interim Report on Underwater Explosives and Explosions", UE-32 OSRD 4874, March-April (1945) 3) R.H. Cole, "Underwater Explosions", Princeton Univ Press, Princeton, NJ (1948) 4) H.G. Snay & J.H. Rosenbaum, "Shock Wave Parameters in Fresh Water for Pressures up to 95 Kilobars", NOL Rept NavOrd 2383 (1952)
 5) M.H. Rice & J.M. Walsh, "Equation of State of Water to 250 Kilobars", JChemPhys 256, 824(1957) 6) H. Snay, "Unterwasser Explosionen, Hydromechanische Vorgänge und Wirkungen", Jahrbuch der Schiffbautechnischen Gesellschaft, 51 Band (1957) 7) Cook (1958), 327-29 (Underwater explosions and shock waves); 328 (Underwater strength methods); 331-35 (Underwater sensitivity) 8) L.V. Al'tshuler et al, "Phase Transformations of Water Compressed by Strong Shock Waves", Soviet Physics-Doklady 3, 761(1958) 9) C.H. Winning, "The Underwater Shock Wave Initiation of Cast Pentolite," PrRoySoc 246A, 288-97(1958) 10) D. Price, ChemRevs 59, 819-23(1959) & CA 54, 897(1960) 11) M.A. Thiel, "Revised Similitude Equations for the Underwater Shockwave Performance of Pentolite and HBX-1", NOL, NavWepsRept 7380(1961) 12) S.A. Berger & M. Holt, "Implosive Phase of a Spherical Explosion in Sea Water", PhysFluids 5, 426(1962) 13) N.L. Coleburn & B.E. Drimmer, "Spherical Shock Waves in Water", APSBull, Ser II, Vol 7, p 20 (1962) 14) W.A. Walker & H.M. Sternberg, "The Chapman-Jouguet Isentrope and the Underwater Shockwave Performance of Pentolite", 4thONRSympDeton (1965), pp 27-38 (26 refs) 15) T.P. Liddiard Jr, "Initiation of Burning of High Explosives by Shock Waves", Ibid, p 488-90 (Underwater testing of HE's)

Detonation (and Explosion), Unstable. See Detonation (and Explosion), Steady and Non-steady State in and also Detonation (and Explosion), Transients and Unstable Detonation Processes

Section 11 DETONATION (EXPLOSION AND DEFLAGRATION) VELOCITY

Rate of Detonation or Velocity of Detonation. (Vitesse de détonation in Fr; Detonationsgeschwindigkeit, in Ger; Velocità di detonazione, in Ital; Velocidad de detonación, in Span; and Skorost' detonatsii, in Rus). Detonation velocity is the rate at which a detonation wave propagates thru an explosive charge, and it depends mostly on the heat of explosion. The rate is usually expressed in meters per second, but in the US industrial and military practice, the feet per second evaluation is sometimes used. The highest velocity ever registered for explosives of high brisance is ca 9000m/sec. In order to reach such maximum velocity for a solid HE, it must be compressed to the highest density (or be cast), be confined in a thick-walled container and be initiated with strong detonator combined with a booster. The diameter of the charge must not be smaller than a certain minimum diam at which deton is still high-order and steady. This diam is characteristic for each expl and each density. It is known as *critical diameter*, because below its value the detonation proceeds at a lower velocity and not thru all the length of the expl chge. The rate of deton might be still lower if the column of small diam is not confined or confined only slightly, as by a glass or cardboard tube instead of a steel one. For a large diam column, the degree of confinement is not of such importance and full rate of deton may be reached without any confinement if diam of charge is very large. This is because the outer portion of large diam column serves as a confining medium for the inside of the charge, thus preventing the loss of energy in directions at right angles to the axis of the column. For HE compds of chge diams above critical and at constant density, the deton proceeds at ever increasing vel with an increase in diam until a certain maximum vel is reached. The diameter at which this takes place is known as the *limiting diameter*, because above it there is no practical increase in vel. If an expl is a mixture contg some insensitive ingredients, such as AN, the max vel reached at limiting diameter starts to decrease at values

above limiting diam. Particle size is practically of no importance for pure HE or their mixts, provided their densities are above critical. The effect is noticeable for expl mixts contg either inert or insensitive ingredients, such as Guhrdynamite, Cheddites or Amatols. Effect of brisance was discussed in Vol 2, pp B297 to B299, listed here as Ref 73

If an expl is improperly initiated or has become desensitized in storage, a deton wave can, in some cases, progress thru the expl column at lower than the normal (high-order) rate. This happens especially with liquid and gelatinous expls. For example, NG, which usually detonates at the rate of ca 8000 m/sec, can also propagate at ca 1500 m/sec if improperly initiated. Some Gelatin Dynamites desensitized in storage can propagate at about half the original rate (Ref 54, p 41)

Dunkle (Ref 61, p 205) made a list of factors affecting the deton velocity. We added to them a few more and made the following list:

- 1) Chemical nature of explosive
- 2) Heat of explosion
- 3) Brisance or shattering effect
- 4) Charge density
- 5) Charge diameter
- 6) Degree of confinement
- 7) External pressure
- 8) Homogeneity of the explosive, especially important for mixtures
- 9) Inert additives and components
- 10) Initial temperature of charge
- 11) Initiation method
- 12) Magnetic and electrical fields
- 13) Oxygen balance of explosive
- 14) Particle size

The strong influence exerted by many of these factors, especially degree of confinement and charge diameter, shows that the energy release which is initiated in the deton front does not occur instantaneously. Hence, any theory (such as "curved-front" or "nozzle") must take into consideration the lateral expansion (See Ref 61, pp 188-201). This expansion (if at all appreciable during time t , where reaction zone thickness is $a=Dt$) will modify the deton process because: a) part of the energy released is used in the expansion (See Ref 61, p 201), hence does not contribute to propagation of the wave front, and b) peak temp and pressure are lower than when lateral expansion

can be neglected (Ref 61, p 205)

Detonation velocity can be either calculated or determined experimentally

A. Calculation of Detonation Velocity. Various calcn methods are described in Refs 24, 26, 27, 32, 33, 36, 46, 48, 61, 62, 64, 66, 69, 70, 72, 74, 75

Following discussion is based on the write-up of Cook (Ref 62, pp 44-50)

So-called *ideal detonation velocity* D^* corresponds to the theoretical maximum, which can be calcd by hydrodynamic theory equations, or it can be determined experimentally. It is the steady value attained at a sufficiently long distance from the initiator in a charge of diameter sufficiently large that further increase in either length or diam will not cause an increase in velocity. A higher than D^* velocity in a given expl may be observed in case of *overboosting*, but this occurs only in the immediate vicinity of the booster and is always accompanied by velocity decay until, at sufficiently long distance from the initiator, the velocity will have settled down to D^* , if the conditions are ideal, or to a lower velocity $D < D^*$ if they are nonideal. Expls detonating at vels higher than D^* are said to be *overdriven*

Nonideal detonation velocity, D , refers to steady-state (long chge length, L) wave propagating at lower than the D^* value, although it is initiated to high-order detonation. Vel D is lower than D^* because it is associated with the rate of conversion of the explosive to its products of detonation and lateral heat and pressure losses. Still lower deton vels can be obtd if an expl is *underboosted*. Velocities, greater or smaller than D^* , associated with over or underboosting and with other effects are described by Cook under the heading "Transient and Unstable Detonation Waves", pp 50-7

The velocity of ideal deton is completely determined by the thermohydrodynamics of the explosive, with the independent variables being the original density ρ_1 of the expl and its chem compn, all quantities being calculable, at least in principle, thru the thermohydrodynamic theory and an appropriate equation of state. For each given ideal explosive, velocity is a function only of the original density, i.e., $D=D(\rho_1)$, but three fundamentally different types of $D(\rho_1)$ relations have been found in ideal deton. The most common is the linear $D(\rho_1)$ relation characteristic of solid C-H-N-O expls at densities

betw ca 0.5 and the cryst density of the expl. This relationship may be expressed by the eq:

$$D^* = D_{\rho_1^0}^* + M^*(\rho_1 - \rho_1^0) \quad (3.1)$$

where $D_{\rho_1^0}^*$ is the deton vel at the density ρ_1^0 and M^* is the slope of the velocity-density curve or line, the asterisk designating the ideal detonation

A similar equation is given in the book of Andreev & Belyaev (Ref 66, p 193)

For direct comparison of explosives, it is frequently convenient to select $\rho_1^0 = 1.0 \text{ g/cc}$. While the actual vel of a given chge may be measured with present methods with an accuracy of ca 0.1%, the $D(\rho_1)$ curve is seldom known this accurately, owing to fluctuations in density of the chge and exptl error in the evaluation of ρ_1 . In cast, pressed and liquid expls, it is possible to determine density very accurately, but in loose, granular chges an accuracy better than 2.0% is seldom attained. For this reason the literature frequently shows discrepancies of this magnitude in $D_{\rho_1^0}^*$ and M^* factor of eq 3.1. Table 3.1 of Cook, shown here in abbreviated form as Table O, lists parameters of some Amer expls:

Table O

| Explosive | Density (ρ_1), g/cc | Velocity $D_{\rho_1^0}$, m/sec | Factor, M^* |
|-----------------|-------------------------------|------------------------------------|------------------|
| TNT | 1.0 | 5010 | 3225 |
| PETN | 1.0 | 5550 | 3950 |
| 50/50-Pentolite | 1.0 | 5480 | 3100 |
| RDX | 1.0 | 6080 | 3590 |
| Comp A | 1.6 | 8180 | 4000 |
| Comp B | 1.6 | 7540 | 3080 |
| Tetryl | 1.0 | 5600 | 3225 |
| PA | 1.0 | 5255 | 3045 |
| Haleite (EDNA) | 1.0 | 5910 | 3275 |
| Amm Picrate | 1.0 | 4990 | 3435 |
| NGu | 1.0 | 5460 | 4015 |
| 50/50-Amatol | 1.0 | 5100 | 4150 |
| DINA | 1.0 | 5950 | 2930 |
| LA | 4.0 | 5100 | 560 |
| MF | 4.0 | 5050 | 890 |

Since velocities in the ideal deton of gases obey closely the ideal-gas law (as shown by the fact that the measured vel agrees with that computed from the thermohydrodynamic theory), a common assumption was that D^* for ideal gases is independent of ρ_1 . Owing, however, to the influence of density on the dissociation of the products of deton at the high temps of deton and the influence of molecular wt on particle velocities, the vel turns out actually to be a slowly varying function of density. Cook's discussion on studies of mixts of $\text{H}_2\text{-O}_2\text{-N}_2$, $\text{H}_2\text{-O}_2\text{-A}$, $\text{C}_2\text{H}_2\text{-O}_2$, and others is given here under Detonation (and Explosion) Velocity in Gases. Equation 3.2 of Cook is given there and also Table 1, reproduced from the constants of eq 3.2 for several gaseous explosives. In Fig 3.1 of Cook are given curves (or rather straight lines) of velocity D versus $\log p_1$ (psia) for those gaseous expls. This Fig is not reproduced here

Returning to the discussion on condensed expls, Cook states on p 45 that interesting examples of nonlinear $D^*(\rho_1)$ curves in solid expls are those observed with the aluminized expls 80/20-Tritonal and 75/25-Comp B-Al (HBX). Fig 3.2, p 47 gives velocity versus density of the above expls, while Fig 3.3 deals with velocity vs diameter for the same expls. Both of these Figs are reproduced here as Figs 1 & 2 under DETONATION VELOCITY-CHARGE DIAMETER AND DENSITY RELATIONSHIPS. These curves were obt'd at large enough diameters to ensure ideal deton

If a diameter of charge is not sufficiently large, an explosive initiated to produce a steady-state propagation wave will act as a nonideal expl. The $D(\rho_1)$ curves for nonideal expls normally have an even greater slope at a given density than for ideal expls, owing to the effect of density on the reaction rate. Figs 3.4 & 3.5 of Cook (p 48) deal with nonideal deton of various expls. These Figs are reproduced here as Figs 3 & 4 under DETONATION VELOCITY-CHARGE DIAMETER AND DENSITY RELATIONSHIPS and the whole subject of nonideal detonation velocities is described more comprehensively than here

Computer methods called HEMP, TIGER & RUBY, used to calculate deton vel and other parameters of solid & liq expls are described

under Computers and Computer Programs in Section 1 of this Volume

B. Experimental Determination of Detonation Velocity. Historical background for development of methods for exptl determination of deton velocities is already given in Vol 3 of this Encycl (Ref 75), pp C310-R and C311-L, under Chronographs and Other Devices Used for Measuring Detonation Velocities of Explosives. Of the earliest methods the methods of Mettegang (Ref 1) and of Dautriche (Ref 2) are still in use, mostly in Europe and South America. Both of these methods are described in Vol 3 of Encycl, pp C311-R to C313-R (Ref 75)

The current methods of exptl detn of deton velocities may be roughly subdivided into: 1) optical and 2) chronographic

The *optical* methods are described in Vol 2 of Encycl (Ref 73), p C13 to C19 under CAMERAS HIGH-SPEED PHOTOGRAPHIC, while the *chronographic* methods are in Vol 3 (Ref 75), p C304 to C319, under CHRONOGRAPHS

Mason et al (Ref 38) detd experimentally at the BurMines, deton vels and some other parameters of HE's. A résumé of their work is given below in the following progress reports:

a) Progress Rept, Jan-March 1948. PETN powder of av particle diam 11.6 and 8.3 microns packed in plastic tubes of ID 1.91 - 1.93 cm at densities 0.70 and 1.00 g/cc: When using cathode ray oscilloscope the av vel was 4680 m/sec for d 0.70 & 5604 for d 1.00; the corresponding values with modified electronic oscilloscope were 4315 & 5536 m/sec

b) Progress Rept, July-Sept 1948. Deton vel of PETN of loading d 1.50 g/cc, using the same method as in a), was 7600 m/sec

c) Progress Rept, Oct-Dec 1948. Deton vel of PETN of particle diam 10 microns, chge diam 1.92 cm, gave the following av value for station distance 10 cm (See Table 1)

Table 1

| Density, g/cc | Velocity, m/sec |
|---------------|-----------------|
| 0.60 | 4120 |
| 0.68 | 4310 |
| 0.95 | 5240 |
| 1.21 | 6510 |
| 1.55 | 7560 |

d) Progress Rept, Apr-June 1949. Deton vels have been obtd for micron-size and coarse-grain Tetryl and TNT at several loading densities. The results were evaluated by comparing the interval recorded on the sweep-trace of a cathode-ray tube by electrical signals from the two stations in the test chge with an adjacent trace record of a one-mega-cycle crystal oscillator. The separation of the signal stations was 10 cm with station No 1 located 5 cm from the detonator

Velocities for Tetryl, chge diam 1.92 cm are in Table 2

Table 2

| Av particle diam, microns | Density, g/cc | Velocity, m/sec |
|---------------------------|---------------|-----------------|
| 10 | 0.70 | 4310 |
| 10 | 1.60 | 7200 |
| 800 (20 mesh) | 0.95 | 4940 |
| 800 | 1.62 | 7470 |

Velocities for TNT, chge diam 1.92 cm are in Table 3

Table 3

| Av particle diam, microns | Density, g/cc | Velocity, m/sec |
|---------------------------|---------------|-----------------------|
| 5 | 0.75 | 3660 |
| 5 | 1.55 | 6630 |
| 800 (20 mesh) | 0.97 | Incomplete Detonation |
| 800 | 1.54 | 6700 |

e) Progress Rept, July-Sept 1949. Deton vels of PETN pdr, chge diam 1.90 cm, station distance ca 10 cm:

| | | | | | |
|----------|------|------|------|------|------|
| Density | 0.68 | 0.80 | 1.10 | 1.40 | 1.56 |
| Velocity | 4160 | 4730 | 5990 | 7270 | 7445 |

f) Progress Rept, Oct-Dec 1949. Deton vel of Tetryl of 10 microns size propagated at a distance of ca 10 cm:

| | | | | |
|----------|------|------|------|------|
| Density | 0.85 | 1.04 | 1.26 | 1.57 |
| Velocity | 5040 | 5750 | 6415 | 7405 |

g) Progress Rept, Jan-March 1950. Deton vel of Primacord by cathode-ray tube method using the multichannel input with 6 stations gave an

av vel of 6245 m/sec. Deton vel for 65/35- N_2O_4/C_6H_6 mixt in thick-walled plastic tubes and station distance of 10 cm was 6875, while for 75/25 mixt it was 7110 m/sec

h) Progress Rept, Apr-June 1950. Deton vel of coarse Tetryl of d 1.59 was 7395, while micron-size TNT gave 6540 m/sec at d 1.46

Axial shock-wave velocities in air were detd by placing the chges with the axis toward the radiation slit aperture, using a circular opening of 3 mm and obtg luminosity records. These records were used to det the axial vels of the shock wave for short distances from the end of chge. Knowing the distance from the end of the expl to the slit aperture, the av shock-wave velocity was calcd from the time interval betw the appearance of detonation peak and the shock-wave peak on the luminosity record. The data in Table 4 show the high axial shock-wave vels observed adjacent to the ends of the expl chges for interval of 3 cm from the end of chges

Table 4

| Explosive | Density | Shock-wave Velocity, m/sec | Shock-wave to Deton Velocity |
|-----------|---------|----------------------------|------------------------------|
| PETN | 1.64 | 6680 | 0.85 |
| Tetryl | 1.64 | 6180 | 0.82 |
| TNT | 1.54 | 6000 | 0.89 |

i) Progress Rept, July-Sept 1950. Investigation of the effect of particle size on deton vel of TNT did not give conclusive results

j) Progress Rept, Oct-Dec 1950. No work was reported

k) Progress Rept, Jan-March 1951. Deton vels for TNT chges, each consisting of pellets of three diameters (1, 1½ & 1-5/8 inches), of either 500 or 1000 microns particle size with corresponding densities 1.18 & 1.21 g/cc. The results showed that the chges (which were initiated with .25 g Tetryl boosters) did not deton at a stable uniform vel. A high vel carry-over from the Tetryl booster was greatest in the 1000-micron sized chges when initiated at the small diam end; however, in both tests the deton faded before reaching the end pellet and a quantity of unexploded TNT was recovered after the test. The chges of 500-micron size propagated with greater uniformity and, considering the average, the vel was independent of the size at the initiated end

l) Progress Rept, Apr-June 1951. Testing with hollow Tetryl pellets of loading d 1.52 having cylindrical cavity 7 mm in diam and 3.9 cm in length showed that cavity increased the apparent deton vel to 8000 m/sec as compared with a steady-state vel of 7200 in solid pellets

m) Progress Rept, July-Dec 1951. Studies of the velocity behavior of the flame front in traversing the boundaries from higher to lower d of Tetryl (1.6 to 1.2) and from lower to higher d showed that there was some decay to the established velocity

n) Progress Rept, Jan-March 1952. Studies of deton vel behavior in traversing the boundaries betw pellets of Tetryl of the same d (1.6) in lengths of 1.0 & 2.5 cm and diam 20 mm, showed only a slight decay when the pellets were joined with Duco cement. The decay in vel was higher when thin paper (0.25 mm) rings were introduced at pellet boundaries

o) Progress Rept, Apr-June 1952 - no work on deton vel reported. Ibid, Progress Repts, July 1, 1952 to June 30, 1953, OrdnProject TA3-5001

p) Progress Rept, July-Sept 1952. Summary of work done up to Sept 1952

q) Progress Rept, Oct-Dec 1952 and Jan-March 1953 - no new data reported

r) Progress Rept, Apr-June 1953. Deton velocities for pelleted Tetryl charges of two loading densities in air and propane were detd, including a comparison of vels for cemented vs noncemented chges at the high d. Station distance was 8.8 cm for d 1.62 chges and 7.1 for d 1.22

Table 5

| Density g/cc | Pellet Boundary | Surround and Impregnant | Velocity m/sec |
|--------------|-----------------|-------------------------|----------------|
| 1.62 | Cemented | Air | 7341 |
| 1.62 | Noncemtd | Air | 7364 |
| 1.62 | Cemented | Propane | 7449 |
| 1.22 | Noncemtd | Air | 6502 |
| 1.22 | Noncemtd | Propane | 6525 |

Gibson & Mason (Ref 49) continued the work on expl detn of deton vels and following is the resumé of their progress reports:

a) Progress Report No 1, July-Sept 1953. The apparatus used for detn of temperature of deton

was tried for detn of velocity. Several experiments were conducted utilizing its electro-optical system to display the transit time of the luminous wave at the charge exterior between predetermined points on an expl chge. A lucite rod, slightly greater in length than the chge, was prepd by filing notches in the rod at 1-cm intervals and then attaching it to a bare expl chge with the openings toward the chge. As the luminous zone passed these notches, a burst of light was transmitted thru the rod and sensed by the receiver unit. Each burst appeared as a pip superimposed on the background radiation but clearly discernible. Other methods for measuring deton vels were contemplated

In measuring deton vels of expl gases, one or several methods were used, such as: a) Direct photography with drum or rotating mirror cameras; b) Schlieren photography with drum cameras; and c) Spark shadow photography. These methods are described in Vol 2 of this Encycl, pp C13 ff, under CAMERAS, HIGH-SPEED PHOTOGRAPHIC. For mixts H_2/O_2 , the highest value, averaging 3100 m/sec, was obtained for % H_2 =71.2 and the lowest, 2540 m/sec for H_2 =61.9%

b) Progress Rept No 2, Oct-Dec 1953 - was not at our disposal

c) Progress Rept No 3, Jan-March 1954. No values for liquid or solid expls were reported, but only for gaseous mixts of $CO/O_2/H_2$. The highest value, 1900 m/sec, was obtained for mixts CO/O_2 ratio=1.99 contg 27.7% H_2 ; the mixts of CO/O_2 ratio=2.04 contg 1.6% H_2 gave 1660 m/sec.

d) Progress Rept No 4, April-June 1954 - no work was reported

e) Progress Rept No 5, July-Sept 1954 - no work on liquid or solid expls was reported, but the values for gaseous expls such as $CO/O_2/H_2$ mixts agreed closely with those of No 3 rept

f) Progress Repts Nos 6, 7 & 8 covering the period from Oct 1954 to June 30, 1955. No work on deton vels reported

In TM9-1910 (Ref 54) are given the following values (See Table 6) for deton vels of some military expls at different densities

Table 6

| Explosive | Velocities, m/sec | | | |
|---------------|-------------------|----------------|------|------|
| RDX | 7650 at d 1.50 | 8400 at d 1.71 | | |
| PETN | 7525 | 1.50 | 8300 | 1.70 |
| Haleite | 7570 | 1.50 | 7750 | 1.55 |
| Tetryl | 7125 | 1.50 | 7850 | 1.71 |
| NGu | 7450 | 1.50 | 7650 | 1.55 |
| PA | 6775 | 1.50 | 7350 | 1.70 |
| PA, cast | | | 7750 | 1.71 |
| Explosive "D" | 6710 at d 1.50 | 7150 | | 1.63 |
| TNT | 6620 " " 1.50 | 6970 | | 1.60 |
| TNT, cast | | | 6675 | 1.57 |

Mason et al (Ref 53) described in Progress Rept No 10, Oct-Dec 1955 exptl detn of deton vels for Tetryl chges at the explosives-rod probe interface and gave the following maximum values 7750 m/sec at d 1.66 and 7209 at d 1.52

McGarry & Stevens (Ref 58) detd deton vels of several military expls after storing them at various temps for 16 hrs. TNT was also stored for 24 and 72 hrs. The charges consisted of sticks of 1-1/8 inches in diam & 18 inches long. The apparatus used was the drum camera previously described in PATR 1465 (1945) (See Table 7)

Their conclusion was that 16 hr storage at -65° & $70^\circ F$ of the above HE's did not affect their deton rates, but 72-hr storage of TNT at $140^\circ F$ caused appreciable lowering of its rate of detonation

Table 8 lists some military and commercial explosives in diminishing order of their detonation velocities, together with other properties, such as heats of formation, combustion and detonation (or explosion), as well as explosion (or ignition) temperature and temperature of detonation (or explosion). Comparing these properties with corresponding detonation velocity values shows that there is no relationship similar to that shown in Table II, p B298 of Vol 2 of Encycl between detonation velocity and brisance

The values given in Table 8 are taken from Cook (1958), pp 45 & 404-05; Andreev & Belyaev (1960), pp 538-65; and PATR 1740, published in 1967 as AMC Pamphlet AMCP 706-177

Table 7

| Explosive | Storage, °F | Density, g/cc | Detonation Rate, m/sec |
|-----------------------|-------------|---------------|------------------------|
| Cast 50/50 Pentolite | 16hr at -65 | 1.67 | 7470±176 |
| | 16hr at 70 | 1.66 | 7440±122 |
| Cast Composition B | 16hr at -65 | 1.69 | 7720 ± 62 |
| | 16hr at 70 | 1.69 | 7660 ± 43 |
| Tetryl Pellets | 16hr at -65 | 1.52 | 7150 ± 46 |
| | 16hr at 70 | 1.53 | 7170±111 |
| Comp A-3, Pellets | 16hr at -65 | 1.51 | 7600±145 |
| | 16hr at 70 | 1.51 | 7620 ± 53 |
| Comp C-4, hand tamped | 16hr at -65 | 1.36 | 7020 ± 87 |
| | 16hr at 70 | 1.35 | 7040±130 |
| RDX Pellets | 16hr at -65 | 1.61 | 8100 ± 92 |
| | 16hr at 70 | 1.62 | 8050±124 |
| Cast TNT | 16hr at -65 | 1.63 | 6700 ± 65 |
| | 16hr at 70 | 1.62 | 6820 ± 69 |
| | 24hr at 140 | 1.64 | 6770 ± 52 |
| | 72hr at 140 | 1.64 | 6510 ± 62 |

Detonation velocities & power values of various expls are given in Table 1, Vol 2 of Encycl, p B266 ff under Brisance or Shattering Effect

If more detailed information is required on the methods for detn of velocities already described in Vols 2 & 3 of Encycl and for the methods not described but just mentioned here, the following references may be consulted: 9,11, 12, 13, 14, 15, 17, 18a, 20, 21, 22, 23, 24a, 25, 28, 30, 32, 34, 35, 37, 38, 40, 41, 44, 45, 46, 47, 49, 51, 52, 53, 55, 56, 57, 58, 60, 61, 62, 63, 64, 65, 66, 67, 68, 69, 70, 71, 73, 74, 75, 76, 77, 81, 82, 83 & 84. [See also Detonation Velocity, Fauquignon et al Method of Determination; Detonation Velocity, Free Surface Imparted to Metallic Plates Method; Detonation Velocity by Metallic Transition of Sulfur Method and Detonation, Water or Plexiglas Induced Shock Wave Velocity Method]

Refs: 1) H. Mettegang, 5th Intl Congr of Applied Chemistry **2**, 322(1903) 2) H. Dautriche, CR **143**, 641(1906) 3) C.E. Bichel, SS **3**, 403-05(1908) 4) H. Kast, SS **8**, 88-93(1913) 5) R. Förg, SS **11**, 17-22 & 37-44(1916) 6) Marshall **2** (1917), 477 7) Barnett (1919), 185 8) P. Lafitte, CR **178**, 1277-79(1924) 9) J. Wagstaff, PrRoySoc **105A**, 282-98(1924) & CA **18**, 1910(1924) (Determination of deton velocity based on the measurement of discharge of an electrical condenser required for the deton of a column of expl which is so arranged that the leading wire from one pole of the charging battery passes thru the initiating end of the expl column to one of the faces of the condenser, while the wire from the other pole of the battery goes thru the final end of the cartridge to the other face of condenser) 10) W. Friederich & P. Vervoorst, SS **21**, 52 (1926) (Determination of deton velocity)

Table 8
Comparison of Detonation Velocities with Other Properties of Explosives

| Explosive | Loading Density, g/cc | Detonation Velocity m/sec | Heat of Formation kcal/kg | Heat of Combustion kcal/kg | Heat of Detonation kcal/kg | Explosion (or Ignition) Temperature, 5 sec | Temperature of Detonation °C | Oxygen Balance, % | |
|--|-----------------------|---------------------------|---------------------------|----------------------------|----------------------------|--|------------------------------|--------------------|-------|
| | | | | | | | | To CO ₂ | To CO |
| 86.5/13.5-TeNME/Toluene | 1.46 | 9300 | - | - | 1759 | - | 5640 | - | - |
| Pentaerythritol Tetranitrate (PETN) | 1.70 | 8300 | 383 | 1960 | 1385 | 225(dec) | 4540 | -10 | +15 |
| Cyclonite (RDX) | 1.65 | 8180 | -93 | 2285 | 1280 | 260(dec) | 4110 | -22 | 0 |
| 70/30-N ₂ O ₂ /NB ₂ | 1.39 | 8100 | - | - | 1842 | - | 5670 | - | - |
| 81.8/18.2-N ₂ O ₄ /Toluene | 1.36 | 8100 | - | - | 1485 | - | 4540 | - | - |
| Composition A-3 | 1.59 | 8100 | - | - | 1210 | 250(dec) | - | -48 | -23 |
| Composition C | 1.5 | 8100 | - | - | - | 285(dec) | - | - | - |
| Tetryl | 1.71 | 7850 | -14 | 2925 | 1130 | 257(ign) | 3500 | -47 | -8 |
| Composition B | 1.68 | 7840 | - | 2790 | 1240 | 278(dec) | - | -43 | -10 |
| 92/8-Blasting Gelatin | 1.55 | 7800 | - | - | 1630 | - | 4970 | - | - |
| Nitroglycerin (NG) | 1.61 | 7800 | 400 | 1616 | 1486 | 222(expl) | 4830 | +3.5 | +24.5 |
| Composition C-2 | 1.57 | 7660 | - | - | - | 285(dec) | - | - | - |
| Nitroguanidine (NGu) | 1.55 | 7650 | 227 | 1995 | 721 | 275(dec) | - | -31 | -15.4 |
| Haleite (EDNA) | 1.49 | 7570 | 134 | 2477 | 1277 | 189(dec) | - | -32 | -10.5 |
| 50/50-Pentolite | 1.66 | 7465 | - | 1549 | 1220 | 220(dec) | 4750 | -42 | -5 |
| 65/35-Tetrytol | 1.60 | 7310 | - | - | - | 325(ign) | - | -56 | -14 |
| Nitroglycol (NGc) | 1.49 | 7300 | 366 | 1764 | 1674 | 257(expl) | 4990 | 0 | +21 |
| Guncotton (13.4% N) | 1.2 | 7300 | - | - | 1060 | 230(dec) | 3040 | -29 | +4.7 |
| Picric Acid (PA) | 1.7 | 7200 | 248 | 2672 | 1000 | 320(dec) | 3230 | -45 | -3.5 |
| Trinitrotoluene (TNT) | 1.63 | 6900 | 78.5 | 3620 | 1080 | 475(dec) | 2800 | -74 | -25 |
| Ammonium Picrate (AP) | 1.55 | 6850 | 395 | 2890 | 800 | 318(dec) | - | -52 | -13 |
| 65%-Gelatin dynamite | 1.55 | 6500 | - | - | 1330 | - | 4100 | - | - |
| 50/50-Amatol | 1.55 | 6330 | - | 1990 | 703 | 265(dec) | - | -27 | -3 |
| Lead Azide (LA) | 4.0 | 5180 | -346 | 630 | 367 | 340(expl) | 3400 | -5.5 | -5.5 |
| Mercuric Fulminate (MF) | 4.0 | 5000 | -226 | 938 | 427 | 210(expl) | 4400 | -17 | -5.5 |
| Lead Styphnate (LSt) | 2.9 | 5200 | -92 | 1251 | 457 | 282(expl) | 2700 | -19 | +2 |
| BkPdr (KNO ₃ 74.0, S 10.4 & C 15.6%) | 1.6 | 400 | - | - | 684 | 427(ign) | 2400 | -22 | -2 |

- 11) G. St.J. Perrott & D.B. Gawthrop, *JFrankl-Inst* **203**, 103-10(1927) (Photographic determination of deton vel) 12) I.A. Luke, *ArmyOrdn* **7**, 366-71 (1927) (Review of methods employed for measuring deton vel including the description of the *Queen Gray Recorder* installed at PicArns) 13) *BurMinesBull* **346** (1931), 60-4 (Detn of deton velocity by Mettegang & Dautriche methods) 13a) F. Olsen & C.J. Bain, *USP* 1801449 (1931) & *CA* **25**, 3487(1931) (Apparatus for detg detonation rate of expls) 14) Vennin, *Burlot & Lécorché* (1932), 121-22 (Detn of vel of propagation of shock waves in gases by Berthelot & Vieille using LeBoulengé chronograph); 158 (Detn by Schultz chronograph); 159-61 (Detn by Dautriche method); 255-60 (Detailed description of LeBoulengé chronograph) 15) Stettbacher (1933), 53-4 (Discussion on deton vel); 54-7 (Mettegang method); 57-9 (Dautriche method); 61-4 (Tables 3 & 4 giving values of deton vels for various expls) 16) W. Friederich, *SS* **28**, 2-6, 51-3, 80-3 & 113-16 (1933) (Deton vels were detd by method of Dautriche for several expls at different densities. A definite relationship was shown betw loading densities and deton vels, especially at higher densities) 17) J.F. Roth, *SS* **28**, 42-6(1933) (Lab detn of vels of some HE's) 18) L.V. Clark, *IEC* **25**, 1389(1933) (Detn of vels of some HE's using Mettegang method) 18a) Pepin Lehalleur (1935), 71-4 (Detn of deton vel by Dautriche method) 19) W. Friederich, *SS* **31**, 253(1936) (Supervelocity of detonation) 20) H. Selle, *SS* **32**, 179-83 (1937) (Exptl detn of velocities by methods of Pouillet, Condenser, Sparkchronograph of Siemens, Optical Chronograph and Dautriche). Fr transln in *MAF* **17**, 173-85(1938) 21) W. Payman et al, "Safety in Mines Research Board No 99 (1937) (Photographic detn of deton vel of solid expls); Ger transln in *SS* **33**, 78 (1938) 22) T. Urban ski, *RozcnikiChemii* **18**, 852-55(1938) & *SS* **34**, 215(1939) (Photographic investigation of detonation phenomena) 23) A. Parisot, *MAF* **18**, 499-598(1939) & *CA* **34**, 4907(1940) (Study of deton vel and initial vel of luminous phenomena in pulverulent expls loaded in glass tubes) 24) G.B. Kistiakowsky & E.B. Wilson Jr, "The Prediction of Detonation Velocities of Solid Explosives", *OSRD* **69**(1941) (PBL Rept 19784) 24a) G.H. Messerly, "A Rotating Drum Camera for the Optical Studies of Detonations", *OSRD* **682** (1942) 25) G.H. Messerly, *OSRD* **803**(1942) & **804**(1942) (Detn of deton vel employing optical method developed at labs of Hercules Powder Co, Wilmington, Del) 26) S.R. Brinkley Jr & E.B. Wilson Jr, "A Revised Method of Predicting the Detonation Velocities of Solid Explosives", *OSRD* **905** (1942) (PBL 31088) 26a) Yu.B. Khariton & S.B. Ratner, *DoklAkadN (ComptRendAcadSci)*, **41**, 293-95 (1943) (in Engl) & *CA* **38**, 6097(1944) (On the velocities of detonation of NG and NGc) 27) S.R. Brinkley Jr & E.B. Wilson Jr, "Calculation of the Detonation Velocities of Some Pure Explosives", *OSRD* **1707** (1943) (PBL 18858) 28) Davis (1943), 14-18 (Detn of deton vels by LeBoulengé and Dautriche methods) 29) F.J. Martin & G.H. Messerly, "The Detonation Velocity of Explosive Mixtures Containing Ammonium Picrate", *OSRD* **3411** (1944) 30) Vivas, Feigenspan & Lardreda **4** (1944), 29-33 (Velocity of propagation of detonation wave); 62-72 (Exptl detn of deton by Mettegang and Dautriche methods) 31) H.A. Strecker, "Rate Studies on Primacord Detonating Fuse", *OSRD* **5610** (1945) 32) Pérez Ara (1945), 53-5 (Calculation of deton vel by the formula of Berthelot); 92-6 (Exptl detn of deton vel by chronographs of LeBoulengé and Mettegang); 97-8 (Detn by accelograph of Duprez); 98-100 (Detn by Dautriche method) 33) D.P. MacDougall et al, "The Rate of Detonation of Various Explosive Compounds and Mixtures", *OSRD* **5611** (1946) 34) C.R. Niesewanger & F.W. Brown, "Electronic Chronoscope for Measuring Velocities of Detonation of Explosives", *USBurMinesReptInvest* **RI 3879** (1946)

- 35) D.P. MacDougall, *PhysRev* **72**, 176(1947) (Exptl studies of deton vels in HE's) 36) M.A. Cook, *JChemPhys* **15**, 523-24 (1947) (Calcn of deton vel) 36a) J.L. Copp & H.R. Ubbelohde, *TrFaradSoc* **44**, 658(1948) (Detn of deton velocities) 37) Stettbacher (1948), 10-12 (Detn of deton vel by spark chronograph and rotating drum camera) 37a) Caprio, Vol 1 (1948), 55-62 (Detn by Dautriche method); 62 (Table of deton vels of some HE's); 63 (Table listing some methods of exptl detn) 38) C.M. Mason et al, "The Physics and Chemistry of Explosive Phenomena", *USBurMines, ProgrRepts*, Jan 1948 to June 1952, Contract NA onr 29-48, Project NR 053 047 39) W.B. Cybulski et al, *PrRoySoc* **197A**, 51-72 (1949) & *CA* **44**, 1707 (1950) (Vel of deton of cast TNT) 40) W.M. Evans, *PrRoySoc* **204A**, 12-17 (1950) (Deton vels measurements) 41) C.H. Johansson & U. Langefors, Iva (Stockholm) **22**, 1-9 (in English); *CA* **45**, 9269(1951) (Description of modifications in Dautriche method, designed to increase the accuracy of measurements) 42) E.A. Christian & H.D. Snay, "Analysis of Experimental Data on Detonation Velocities", *NavOrdRept* **1508** (1951) 43) L. Médard, *MP* **33**, 352(1951) (Deton vels) 44) Belgrano (1952), 30-6 (Deton vel by Dautriche method); 36-8 (Ditto by Mettegang method) 45) Stettbacher (1952), 12-15 (Detn of deton vel by rotating drum camera); 132-33 (Table giving deton vels and other parameters of liq & solid expls) 46) Taylor (1952), 24-29 (Measurement of deton vel); 118-27 (Calcd and observed values for various expls) 47) T. Hikita & K. Yoneda, *JIndExplsSocJapan* **14**, 30-3 (1953) & *CA* **49**, 5841 (1955) (A method for measuring deton vels of short charges) 48) T. Sakurai, *JIndExplsSocJapan* **14**, 257-64 (1953) (Propagation velocity of shock waves in solids) 49) F.C. Gibson & C.M. Mason, "Detonation and Explosives Phenomena", *USBurMinesProgressRepts*-Nos 1 to 8, from July 1, 1953 to June 30, 1955, *OrdnProject* TB2-0001, *ArmyProject* 599-01-004 50) Dr. H. Elsner & Dynamit AG DRP 876821, described in *Explosivstoffe* **1954**, 20 (Method for raising deton vel of phlegmatized expls consists of incorporation of heavy inorg salts, preferably those of density 3, such as Ba sulfate, Ba chromate, Pb sulfate, Pb chromate, etc. The salts must be fairly divided, such as in powder, filings, shavings, small crystals, etc and incorporation can be made either by mixing with phlegmatizer alone or by mixing with already phlegmatized expl) 51) S. Yamamoto et al, *JIndExplsSocJapan* **15**, 304-06(1954) & *CA* **49**, 11282(1955) (A counter-chronograph method for detg deton vel) 52) M.A. Cook et al, *JApplPhys* **26**, 426-28 (1955) & *CA* **49**, 9277(1955) (Measurement of deton vel by Döppler effect at 3-cm wave length) 53) C.M. Mason, F.C. Gibson & A. Strasser, "Research Program on Detonation and Explosives Phenomena", *USBurMinesProgressRepts* Nos 9 to 12 from July 1955 to June 30, 1956, *OrdnCorpsProject* TA3-5101, *ArmyProject* 504-01-015 54) Anon, "Military Explosives", **TM9-1910** (1955), 41-2 (Rate of deton) 55) E.F. Pound & M.A. Cook, "The Measurement of Detonation Velocity by Microwave Resonator Techniques", *Univ of Utah, TechRept* **44**(1955), Contract N7-onr-45107 56) H.T. Knight & R.E. Duff, *JSciInstr* **26**, 256-60(1955) (Precision measurement of deton and strong shock vel in gases) 57) R.T. Keyes, "Framing Camera Studies of Phenomena Associated with the Detonation of High Explosives", *Univ of Utah, Inst for Study of Rate Processes*, Contract

- N7-onr-45107, TechRept IL, May, 1956
- 58) W.F. McGarry & T.W. Stevens, "Detonation Rates of the More Important Military Explosives at Several Different Temperatures", PATR **2383**(1956) (OrdProj TA3-5002)
- 59) M.A. Cook et al, JChemPhys **24**, 60-7 (1956) (Velocity-diameter and wave shape measurements and determinations of reaction rates in TNT)
- 60) A.W. Campbell et al, RevSciInst **27**, 567-74(1956) (Precision measurement of deton vels in liquid and solid expls using raster-type oscilloscope which has a sweep linearity of 1% and time coverage of 300 microsecs) (17 refs)
- 61) Dunkle's Syllabus (1957-1958), 205 (Deton vel, various factors affecting it); 206 (Action of confining medium); 209 (Effects of chge geometry); 210 (Evaluation of combined influence of chge diam and confinement); 210-12 (Curved-front and nozzle theory); 212-14 (Effects of chge density, porosity and granulation on deton velocity); 284 (Deton vel transients)
- 62) Cook (1958), 22-32 (High-speed photograph employed in deton studies); 41-2 (Miniature-chge techniques for determination of deton vel); 44-60 (Velocity of propagation of ideal and nonideal detonation waves which included on p 51, low-velocity of deton, called by Cook *metastable*); 111-16 (Free-surface velocity); 211- (Influence of inert additives on deton vel of ideal expls)
- 62a) R.P. Fraser, "Detonation Velocities in Liquid Fuel Vapors with Air or Oxygen at 100°C and Atmospheric Pressure", 7thSymp-Combstn (1959), 783-88
- 62b) L.N. Stesik & L.N. Akimova, ZhFizKhim **33**, 1762(1959) (Width of reaction zone in a deton wave)
- 62c) F.C. Gibson et al, RevSciInstr **30**, 916-19 (Oct 1959) (Method for the Study of Deflagration to Detonation Transition)
- 63) A.C. Gray & S. Thomas, JSciInstr **36**, 304-06(1959) (Photoelectric app for measuring deton vel)
- 64) A.B. Amster et al, "Continuous Oscillograph Method for the Determination of Detonation Velocities in Solid Cast Explosives", NAVORD Rept **6280**(1959)
- 63a) A.B. Amster, RevSciInstr **31**(2), 219-20(1960) (Method for the study of deflagration to deton transition)
- 64) Baum, Stanyukovich & Shekhter (1959), 225-27 (Velocity of deton wave); 303-17 (Exptl detn of deton velocity by the methods of Dautriche, impulse oscillograph, rotating drum camera, rotating mirror camera and electro-optical app)
- 65) PATR **2700**, Vol 1(1960), pX (List of various methods used for exptl detn of deton velocities)
- 66) Andreev & Belyaev (1960), 193-210 (Deton in condensed expls; theoretical part); 210-222 (Experimental methods for determination of deton velocities, which include Dautriche-, photographic-, and oscillographic-methods)
- 67) Spencer Chemical Co, "Ammonium Nitrate Explosives for Underwater Applications", Jan 18, 1960 (Pamphlet, Courtesy of S.J. Porter) [Detn of deton vels of AN expls (such as 94/6-Spencer N-IV AN/Fuel Oil No 2, manufd by Spencer Chem Co)using the Beckman-Whitley High-Speed Framing-Camera. Tests were conducted,using various booster chges, to establish relationship betw vel of deton and density, as well as betw vel and particle size. The values of velocities were betw 1650 & 2460m/sec for prills as received, 4200 for granular and betw 2890 & 3230 for various other particle sizes]
- 67a) M.J. Urizar et al, "Velocity of Pressed TNT", 3rdONRSymp-Deton (1960), 327-56
- 68) V.M. Zaitsev et al, DoklAkadN **132**, 1339-40(1960) & CA **55**, 17007(1961) (An electromagnetic method for the measurement of the velocity of the products of an expln)
- 69) Dunkle's Syllabus (1960-1961), p 11g (Super-detonation velocity); 13b (Supervelocity wave); 18b (Investigation by Allison & Schriempf of velocities in a thin-walled Cu cylinder by means of a high-speed oscillographic pin technique)
- 69a) D.P. Urizar et al, Physics of Fluids **4**(2), 262(1961) (Velocity of pressed TNT)
- 70) I.M. Voskoboynikov & G.S. Sosnova, ZhPriklMekh i TekhnFiz **1961**, No 4, 133-35 & CA **56**, 3712-13 (1962) (Calcd deton velocities and temps of deton were compared with exptl values for mixts of TeNM with C₆H₁₄, CH₃NO₂, C₆H₅NO₂ & DNT; of NG with MeOH & MeNO₂; of carbon suspensions with TNT & TeNMe; and of solid expls, such as Ammonal & Pentolite. Velocities were detd by the ionization method and temperature by optical method)
- 71) J. Sinabell, Explosivst **1961**, 121-31 (Detn of deton vels in thin expl layers)
- 72) H.L. Selberg & T. Sjoln, Explosivst **1961**, 150-54 (in Engl); 154-57 (in Ger) (Deton vel, low- and high-order in metal tubes)
- 73) PATR **2700**, Vol 2(1962),

pp C13 to C19 under CAMERAS (Photographic methods for detn deton vels) 74) L.G. Bolkhovitinov, DoklAkadNauk **130**, 1044-46 (1960) & CA **56**, 2625 (1962) (Deton vel of liquid expls at low rate) 75) W. Pagowski, BullAcadPolonSciSerSciChim **10**, 475-7 (1962) (in Engl) ; CA **58**, 7780 (1963) (Rate of detonation and effective oxygen balance of explosives) 75a) G.S. Sosnova et al, DoklAkadN **149**, 642-43 (1963) & CA **59**, 375-76 (1963) (Light emission by a low-velocity deton front in NG) 76) K. Tanaka, KôgyôKayakuKyôkaishi **26**(3), 145-53 (1964) & CA **61**, 10526 (1964) (Measurements of detonation rates by ion gaps). (The ion gap method is presented as a practical method for the detn of the detonation rate of the explosive charges. This method involves the use of double probes prep'd from a pair of insulated wires having bared tips and is used as a detector for the ionized detonation front. The ion gaps were inserted in the explosive charge at known intervals. As the charge was fired, a pulse train derived from the signal-forming circuits connected to the gaps was recorded by a cathode-ray oscilloscope and a high-speed camera. The change in the elec cond between the gap probes during the passage of the detonation wave was measured prior to the tests. The gap became completely elec conductive just when the wave front arrived, and in a few microsec it became nonconductive again. The breakdown time lags of the wires inserted in the charges were measured. The time required for cutting off the wire by the arrival of the detonation front was <10 microsec when a thin wire of <1 mm diam was inserted into the com charges. The recovery of noncond of the ion gap can be attributed to the breakdown of the leads. Results of the measurements of the detonation rate with various com charges are presented. The method allows an easy multipoint measurement and gives accurate results owing to the minuteness of the wave-front detector) 77) Anon, PATM **1599** (1965) (Experimental data on the deton rates of several mixed expls) (Transln from Russian prep'd for PicArns by USJoint-Publication Research Service) 78) Le Roy G. Green & E. James Jr, "Radius of Curvature Effect on Detonation Velocity", 4thONRSymp-Deton (1965), 86-91 79) M.L. Pandow et al, "Studies of the Diameter-Dependence of De-

tonation Velocity in Solid Composite Propellants I. Attempts to Calculate Reaction Zone Thickness", Ibid, pp 96-101 80) Ibid, "II. Prediction of Failure Diameters", Ibid, 102-06 81) L.D. Pitts, "Electrical Probe Technique for Measuring Detonation and Deflagration Velocities", Ibid, 616-26 82) M.B. Caid, Bull(Fr), **1965**(10), 2908-15 & CA **64**, 3274 (1966) (Experimental investigation of the limits and of the velocity of the detonation in pure or diluted chlorine dioxide) 83) PATR **2700**, Vol 3 (1966), pp C304 to C319, (Chronographs and other methods for determination of detonation velocities) 84) R.W. Woolfolk & A.B. Amster, "Low-Velocity Detonations: Some Experimental Studies and Their Interpretation", 12thSympCombstn (1968) (Pub 1969), pp 731-39 85) M.F. Zimmer, "Similarity Between Wave Structures of Gaseous and Liquid Low Velocity Detonations", Ibid, p 740 (Paper No 73 in Abstracts, pp 133-34). This material is published in Combustion & Flame **12**, 1-4 (1968)

Detonation Velocity, Anomalous High. Accdg to Dunkle (Ref 1), coarsely granulated charges with air between the particles, may develop deton velocities 200-300 m/sec higher than normal for their loading densities. Such anomalous behavior could be attributed to development of heat due to adiabatic compression of entrapped gases. A different explanation is given by Russian investigators, as explained in Ref 2

Accdg to Baum et al (Ref 2), it was observed that if PETN compressed at 3000 kg/cm² (in the form of a cylinder having a density of ca 1.5 g/cc) was broken into lumps of 4-5-mm size and then loaded in such condition into a Cu tube of 15-mm, the resulting density of chge was only 0.753. When this chge was detond, it developed a velocity of 7940 m/sec, which was much higher than vel corresponding to density 0.753, but practically the same as developed on deton of an unbroken compressed cylinder of PETN (density ca 1.5). The same phenomenon of anomalous deton vel was observed for RDX, LA & MF, but not for TNT

The reason for such anomalous behavior was explained by Bobolev & Khariton in the following manner: If the lumps of an HE are of a size larger than the critical diameter, the detonation propagates inside the tube not in the

shape of a solid front but jumps from one lump to another, each lump detonating at a velocity of ca 7940, corresponding to density of each individual lump (which is ca 1.5). If the size of lumps is below critical diameter (such as in the case of TNT), no anomalous behavior takes place

Re/s: 1) Dunkle's Syllabus (1958), 213
2) Baum, Stanyukovich & Shekhter (1959), 286-87

Detonation Velocity-Brisance Relationship.

See Brisance-Detonation Velocity Relationship in Vol 2 of Encycl, pp B297-L to B299-L, including Table II

Detonation Velocity-Charge Diameter Relationship. Accdg to Taylor (Ref 6), Abel showed in 1874 that the diam of a tube contg a detonating expl influenced the transmission of deton; and in 1891 Berthelot & Vieille found that for a number of expls, the vel of deton increased with the density of charge, with the cartridge diam, and with the strength of envelope. Similar results were later obt'd by Bichel, Mettégang, Dautriche, Kast & others, but nearly all of their investigations were confined to military expls. It was W.G. Hiscock who was the first to examine (ca 1926) commercial expls, such as *Roburite No 4* (TNT 16, AN 60 & NaCl 24%). Table 1, top line, gives some of his results with commercial cartridges without extra confinement, while the bottom line gives velocities of cartridges buried under 2 ft of sand

Table 1

| Diam, in | 7/8 | 1.0 | 1.25 | 1.5 | 1.75 | 2.0 |
|------------|------|------|------|------|------|------|
| Vel, m/sec | 2890 | — | 3680 | 3830 | — | 3880 |
| Vel, m/sec | 3620 | 3660 | 4080 | 4160 | 4380 | 4610 |

Accdg to Burlot (Ref 1) and Parisot & Lafitte (Ref 2), vel of deton generally increases with the diam of cartridge up to a maximum value, above which the vel remains constant. This is true for PA, RDX and for AN/Tetryl mixts contg more than 10% Tetryl, but for some other expls, such as PETN and Tetryl, the curve of deton vel vs cartridge diam increases at first, passes thru a maximum, then decreases and, after passing thru a minimum, rises again

Jones (Ref 4) has proven that vel of deton wave in a cylindrical chge is dependent on its

diam. He calcd the relationship and has shown that this effect depends upon the rate of the chem reaction occurring in the front portions of the deton wave, and that it is possible, therefore, to det this rate of reaction by measuring the vel of deton in bare chges of different diams. The effect of a metal case surrounding the chge was also briefly discussed. He studied deton of compressed charges of TNT at three densities and at three diam sizes. Some of his results are listed in Table 2:

Table 2

| Density, g/cc | Deton Vel, m/sec at diams | | |
|---------------|---------------------------|------|------|
| | 0.75 | 1.0 | 1.75 |
| 1.53 | 6830 | 6920 | 7000 |
| 1.40 | 6350 | 6450 | 6510 |
| 1.34 | 6150 | 6180 | 6210 |

Jones also det'd deton vels for various AN/TNT mixts of ca 1.6 density and found that vel decreased with diam of chge and TNT content. For mixt contg only 30% TNT, no deton took place at 0.75 in diam of chge (quoted from Ref 5, pp 140-41)

Summarizing the work done to ca 1950, Taylor (Ref 5, p 142) stated that the results show that the max or hydrodynamic vel of deton is approached as the diam is increased, but as the diam is reduced the vel fails. Eventually the vel becomes so low that the deton wave is not strong enough to maintain its own propagation. There is, therefore, a critical minimum diam for any expl below which a self-sustained deton wave will not propagate. The critical vel and critical diam bear no direct relation to the hydrodynamics of deton. They are dependent on an ill-defined prop of the expl which is called "sensitiveness". This prop is not completely det'd by the chem nature of the expl but is closely related to its physical state. In some solid expls the critical diam depends on the fineness of the particles, the finest or most finely aerated materials giving the lowest critical diams. On the other hand, some gelatins are capable of self-sustained detons in smaller and smaller diams as the density of the expl is increased by the removal of air bubbles (Ref 5, p 141-42)

Although the general features of the dependence of deton vel on cartridge diam and

on the nature of the environment of the expl had been studied experimentally at intervals over a period of 70 years, little attempt had been made to explain the effects in terms of the hydrodynamics and thermodynamics of the explosive systems. During WWII several approximate theories were developed in Gt Britain and in the USA to account for experimental deviations from the theoretical velocities. These theories are described in this volume as:

- a) Detonation, Curved Front Theory of Eyring et al
- b) Detonation, Geometrical Model Theory of Cook
- c) Detonation, Nozzle Theory or Expanding-Jet Theory of Jones
- d) Detonation, Qualitative Theory

Theories a), c) & d) are described by Taylor (Ref 3, pp 145-52), and theories a), b) & c) are described by Cook (Ref 10, pp 124-28)

Besides description of three approx detonation theories, Cook discussed the relationships between velocities and diameters for several HE's and plotted them on curves shown on pp 47, 48, 49, 50, 129, 130, 131 & 132

Accdg to Baum et al (Ref 11, p 283), investigation of influence of chge diam on deton vel was conducted by Dautriche, Bichel, Kast, etc, but it was done more systematically in the US by Cook and in Russia by Belyaev & Bobolev. It may be considered established now that for an expl compd the velocity increases with chge diam until a maximum is reached at a certain diameter, called "predel'ny" in Rus (which can be translated as "limiting") which is characteristic for each expl. After this there is practically no increase in velocity

Accdg to Andreev & Belyaev (Ref 12, pp 201-02), deton vel increases with diam of chge (if it is above critical) in the manner of an asymptotic curve which approaches the maximum value. Fig 4.38, p 202 of Ref 12, presents a curve of deton vel vs diameter for RDX of density 1.0 and Fig 4.39 for TNT of density 0.85 in fine and large crystals (not shown here)

Relative value of deton vel D/D_{\max} may be approx calcd from relationship d/d_{\lim} , where d is diam as determined and d_{\lim} is "limiting" diameter. For expl having small critical diam, vel increases rapidly with a small increase in diam. For example, Blasting Gelatin of high

density has a critical diam ca 3mm and at this diam the vel is 7600mm, while at 2mm no deton takes place. If diam is increased to 4mm, the vel is 7800 and is the same at diam 5mm. Investigations of Bobolev have shown that RDX of density 1.0 has a very small critical diam (ca 1mm) and its vel is ca 2000m/sec, at diam 1.5mm the vel is ca 5000 and reaches a max (ca 5200) at diam of 2mm. After this there is practically no increase in vel with an increase of diam. For fine-crystalline TNT of density 0.85, critical diam is ca 5mm at which deton vel is ca 2500mm and it is necessary to increase the diam to 15mm in order to obtain the max vel ca 4200. For large grain TNT of density 0.85, the critical diam is ca 10mm with velocity ca 2500m/sec; increase to 15mm brings the vel to ca 3500 and then it is required to increase the diam to 30mm in order to obtain the max vel ca 4200m/sec.

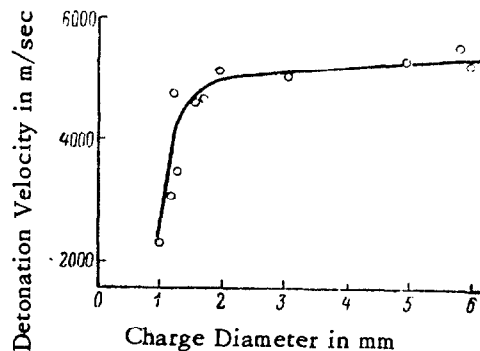

Fig 4.38 Charge Diameter vs Detonation Velocity of RDX of Density ca 1.0g/cc

Refs: 1) E. Burlot, Compt Rend 18^e Congr Internl Chim Ind (Nancy, France), Sept-Oct 1938, 930-36 & 1146-59; CA 33, 6049 (1939) (Study of the effects of charge diam, crystal dimensions & nature of the gas present on the velocity of deton of crystd expls, such as PETN) 2) A. Parisot & P. Lafitte, Compt Rend 18^e Congr Internl Chim Ind (Nancy, France), Sept-Oct 1938, 930-36 & CA 33, 6049 (1939) (Influence of cartridge diam on the vel of deton of expls) 3) Anon, La Chimica e l'Industria 21, 546 (1939) & SS 35, 83 (1940) (Influence of charge diam on the deton velocity) 4) H. Jones, Pr Roy Soc 189A, 415-26 (1947) (A theory of the dependence of the rate of deton of solid expls on the diam of the chge)

4a) H. Eyring et al, ChemRev **45**, 69(1949) (Curved-front theory) 5) R.B. Parlin & D.W. Robinson, "Effect of Charge Radius on Detonation Velocity", Univ of Utah Inst for Study of Rate Processes, Contract N7-onr-45107, TechRept VII, Oct 3, 1952 5a) H. Guénoche & N. Manson, CR **235**, 1617-19 (1952) & CA **49**, 6607(1955) (Variation of velocity of propagation with tube diameter) 6) Taylor (1952), 139-55 (Deton vel-charge diam relationship) 7) M.A. Cook et al, "Velocity-Diameter and Wave Shape Measurements and the Determinations of Reaction Rates in Metal Nitrate-TNT Mixtures", Univ of Utah Inst for Study of Rate Processes, TechRept **XXVI**, Jan 4, 1954, Contract N7-onr-45107 8) M.A. Cook et al, "Velocity Diameter and Wave Shape Studies in Low Density 50/50-TNT/Sodium Nitrate Mixtures", Univ of Utah Tech Rept **XXXVI**, 30 July, 1954, Contract N7-onr-45107 9) M.A. Cook & R.T. Keyes, "Velocity-Diameter and Wave Shape Measurements in the Determination of Reaction Rates of TNT", JChemPhys **24**, 191-201 (1956) 9a) M.A. Cook, "Velocity-Diameter Measurements and Reaction Rates in PETN, RDX and EDNA", Univ of Utah TechRept **37**(4 Aug, 1954), Contract, as in Ref 8 10) Cook (1958), 47-50, 124-28, 129-32 11) Baum, Stanykovich & Shekhter (1959), 283 12) Andreev & Belyaev (1960), 201-03 13) M.L. Pandow et al, "Diameter-Dependence of Detonation Velocities of Explosives-Loaded Formulations" (U), Rohm & Haas Co Special Rept No **S-67**, 20 Aug 1965, Contract DA-01-506-ORD-785 (Z)(Conf) (Not used as a source of info)

Detonation Velocity-Charge Density Relationship.

Accdg to Taylor (Ref 4), p 139), Berthelot & Vieille found in 1891 that vel of deton increased with the density of chge, its diam and strength of confining envelope

Accdg to Schmidt (Ref 1, as quoted from résumé in CA): "That the detonation velocity (D) of explosives increases regularly with the density (d) follows directly from hydrodynamic relations when the thermodynamic behavior of very dense gases is considered. D increases in proportion as the gas vol (v) is decreased by the covol (a):

$$D = v/(v-a) \cdot \mu \cdot \sqrt{k_2 \frac{8310}{M_2} \cdot T_2}$$

where M_2 = mean mol wt, T_2 = temp of detonation, $k_2 = c_p/c_v$ and $\mu = (k_2+1)/k_2$. Calcns from this equation gave results which agreed closely with results of actual tests. Values for a calcd from exptl values for D agreed with those calcd from measurements of the pressures from the combustion of powder. The detonation velocity of the gaseous products of detonation being independent of the influence of a , the detonation pressure can be calcd accurately from d , D , v and T_2 by the equation:

$$P = \Delta \cdot D \cdot w = \Delta \cdot D \cdot \sqrt{\frac{1}{k_2} \cdot \frac{8310}{M_2} \cdot T_2}$$

without regard to a . The results of mol kinetic consideration of the propagation of detonation and the equations which express the dependence of D on the mean mol velocity of the detonation gases are in complete agreement with the hydrodynamic theory of detonation"

Baum et al (Ref 8, p 244) stated that Taffanel & Dautriche and later Schmidt attempted to apply the equation:

$$D = v_0 / (v_0 - a) \sqrt{2(k^2 - 1)Q_v} = 1 / (1 - a \rho_0) \sqrt{2(k^2 - 1)Q}$$

where D = deton vel; a = covolume; ρ_0 = density of loading in g/cc; v_0 = volume of gas; Q = heat of detonation and $k = c_p/c_v$ to calcn of parameters of condensed expls. Their attempts were, however, unsuccessful because the covolumes of solid and liquid expls were unknown

Baum et al (Ref 8, pp 242-44) showed how the above equation is derived from Abel equation of state, thermodynamic laws & Hugoniot equation for ideal gases. They also presented a curve of density-deton velocity relationship for firedamp gas. The curve is nearly a straight line

Baum et al also stated on p 245 that Schmidt calcd deton velocities and other parameters for Tetryl using his equation and obtd the values given in Table 1

Table 1

| Density ρ_0 , kg/l | Covolume α , l/kg | Velocity D, m/sec | Pressure p, atm | Temp, T, °K |
|----------------------------|-----------------------------|----------------------|--------------------|----------------|
| 1.0 | 0.58 | 4700 | 41600 | 3250 |
| 1.29 | 0.52 | 5900 | 67600 | 3530 |
| 1.46 | 0.48 | 6500 | 84000 | 3550 |
| 1.59 | 0.45 | 6900 | 96500 | 3630 |

Schmidt also calcd parameters for other condensed expls, but not in all cases were the agreements betw calcd and exptl values good (Ref 8, pp 244-45)

Baum et al (Ref 8, pp 289) stated that with increase of density, detn vel increases at first rapidly and then slowly, but the increase of vel never stops even at very high densities

Accdg to investigation of Shekhter (Ref 8, p 290) the detn vels of TNT and RDX phlegmatized with 5% wax obey the equation

$$D = B\rho_0^a$$

where ρ_0 is density; $B=5060$ m/sec for TNT & 5720 for RDX; and $a=0.67$ for TNT & 0.71, and for other brisant expls it is ca 0.7

Following table gives relation betw density and detn vel, detd by rotating mirror camera, for TNT & phlegmatized RDX:

Table 2

| Density, ρ , g/cc | Deton Velocity, m/sec for: | |
|---------------------------|----------------------------|--------------|
| | TNT | RDX + 5% Wax |
| 1.25 | — | 6660 |
| 1.30 | 6025 | 6875 |
| 1.35 | 6200 | 7125 |
| 1.40 | 6315 | 7315 |
| 1.45 | 6480 | 7470 |
| 1.50 | 6610 | 7640 |
| 1.55 | 6735 | 7820 |
| 1.60 | 6960 | 7995 |
| 1.61 | 7000 | — |

The above Shekhter equation is not applicable to expl mixts such as Cheddites, Guhr-dynamite and some AN expls. Here detn vel increases with density until it reaches a certain maximum and then it gradually decreases. The max shifts towards higher density with the increase in diam of chge. For example, for chge diam of Cheddite 20mm, the max velocity (ca 2550) is reached at density ca 1.12, while chge diam of 40mm, the max (ca

2900) is reached at density of 1.18 g/cc Messerly (Ref 2) detd detn vels of 12 pure org expl compds using a rotating drum camera. When the data were plotted, all gave straight lines having approx the same slope:

$$D_{d_2} = D_{d_1} + 3770(d_2 - d_1)$$

where D_{d_1} & D_{d_2} are rates of detn at densities d_1 & d_2 , respectively

Caldirola (Ref 3) calcd, using some equations of hydrothermodynamic theory, relation betw density and some detn parameters. The data are given in Table 3

Table 3

| Explosive | Density of chge, g/cc | Velocity of detn, m/sec | Pressure, kg/cm ² | Temp of deton T, °K |
|----------------|-----------------------------|-------------------------------|---------------------------------|---------------------------|
| PETN | 0.8 | 4900 | 65000 | 5050 |
| | 1.00 | 5500 | 95300 | 5320 |
| | 1.20 | 6300 | 140500 | 5720 |
| | 1.40 | 7100 | 195500 | 6170 |
| | 1.60 | 7900 | 262800 | 6670 |
| Tetryl | 1.00 | 5480 | 91800 | 4400 |
| | 1.28 | 6510 | 160400 | 4740 |
| | 1.45 | 7220 | 218100 | 4980 |
| | 1.54 | 7375 | 242500 | 5100 |
| | 1.61 | 7470 | 259100 | 5140 |
| Picric Acid | 1.03 | 5150 | 83000 | 3880 |
| | 1.28 | 5820 | 120700 | 4070 |
| | 1.39 | 6450 | 164600 | 4280 |
| | 1.63 | 7210 | 239400 | 4660 |
| TNT | 1.00 | 4700 | 68700 | 3210 |
| | 1.29 | 5900 | 132800 | 3610 |
| | 1.46 | 6500 | 178000 | 3860 |
| | 1.59 | 6900 | 216200 | 4020 |

Mason & Gibson (Ref 5) detd relationship betw density & detn velocity for two adjacent 5 mm segments (A & B) of a stepped rod of Tetryl at the explosives-rod probe interface. The results are listed in Table 4

Table 4

| Test No 1 | Segment | Deton vel, m/sec | Density g/cc |
|-----------|---------|---------------------|-----------------|
| 1 | A | 7750 | 1.66 |
| | B | 7171 | 1.51 |
| 2 | A | 7611 | 1.63 |
| | B | 7209 | 1.52 |

Cook (Ref 6) gave curves of deton vel vs density for HBX & Tritonal (p 47, Fig 3.2) and for 90/10-AN/DNT and 90/10-AN/Al mixtures (p 49, Fig 3.6) and in Chap 5, pp 91-122 he discussed "Detonation Wave Shape and Density Properties"

Dunkle (Ref 7, p 212) stated that data on deton vels over a wide range of density are usually expressed as a linear function of the density, especially at higher values. He gave the equation of M.A. Cook (Ref 6, p 44), which we prefer to write the way it is given by Andreev & Belyaev (Ref 9, p 193):

$$D_{\rho_1} = D_{\rho_0} + M(\rho_1 - \rho_0)$$

where D_{ρ_1} = unknown velocity at density ρ_1 ;

D_{ρ_0} = known velocity at ρ_0 ; and M = slope of the line, expressed in (m/sec):(kg/liter).

The above equation was derived by Cook for ideal detonations, but it is supposed also to hold for solid organic HE's consisting of CH, N & O at densities betw 0.5 and cryst density of expl. Values of M for various expls were detd by Cook and listed in Table 3.1, p 45 of Ref 6. Some of the values were listed by Dunkle (Ref 7, p 213), but a more complete list was given in Ref 9, p 194, which is shown in Table 5 in a slightly modified form:

Table 5

| Explosive | Density ρ , g/cc | Deton vel, D_{ρ_0} , m/sec | Slope M , (m/sec):(g/cc) |
|-----------------|--------------------------|------------------------------------|-------------------------------|
| TNT | 1.0 | 5010 | 3225 |
| PETN | 1.0 | 5550 | 3950 |
| 50/50-Pentolite | 1.0 | 5480 | 3100 |
| RDX | 1.0 | 6080 | 3590 |
| Tetryl | 1.0 | 5600 | 3225 |
| PA | 1.0 | 5255 | 3045 |
| EDNA | 1.0 | 5910 | 3275 |
| Expl "D" | 1.0 | 4990 | 3435 |
| NGu | 1.0 | 5460 | 4015 |
| DINA | 1.0 | 5950 | 2930 |
| NENO | 1.0 | 5530 | 3680 |
| 50/50-Amatol | 1.0 | 5100 | 4150 |
| Comp A | 1.6 | 8180 | 4000 |
| Comp B | 1.6 | 7540 | 3080 |
| 55/35-Tetrytol | 1.6 | 7300 | 3400 |
| 50/40-Ednatol | 1.6 | 7510 | 3325 |
| Fivonite | 1.0 | 5215 | 3410 |
| Sixonite | 1.0 | 5670 | 3360 |
| LA | 4.0 | 5100 | 560 |
| 4F | 4.0 | 5050 | 890 |

Dunkle also stated (Ref 7, pp 212-13) that there are some exceptions to the rule that the deton vel increases regularly with density. In most of these cases a maximum in deton rate is observed. Two examples of this behavior are given in Table 6

Table 6

| Dynamite No 1 (NG 75 & Guhr 25%) | | Cheddite: 80/13/2/5- KClO ₃ /MNN/DNN/ Castor Oil | |
|-------------------------------------|----------|---|----------|
| Density | D(m/sec) | Density | D(m/sec) |
| 0.63 | 1900 | 0.70 | 2283 |
| 0.85 | 2560 | 0.80 | 2385 |
| 1.34 | 3670 | 1.01 | 2769 |
| 1.54 | 5230 | 1.17 | 2901 |
| 1.62 | 6800 | 1.29 | 2846 |
| 1.69 | 4200 | 1.35 | 2777 |
| 1.71 | 2460 | 1.40 | 2451 |
| 1.74 | Failed | 1.50 | Failed |

At very low densities irregularities are observed, which are presumed to be related to granulation and to the inhomogeneity which can easily occur on settling of the chge which contains air. For similar reasons porosity is important

Andreev & Belyaev (Ref 9) give on p 204, Fig 4.40 curves (which are practically straight lines) for relationship velocity vs relative density (density of chge divided by specific gravity of expl). They also stated (p 205), that for expl mixts, such as Cheddites, consisting of components which either do not detonate by themselves or deton with great difficulty, the velocity increases in the region of moderate densities (such as from 0.7 to 1.1), reaches a maximum and then decreases. A similar occurrence takes place for 90/10-AN/DNT and 90/10-AN/Al mixts (See Figs 4.41 and 4.42, p 205 of Ref 9)

Accdg to Blinov (as quoted from Ref 9, p 205), the location of maximum deton vel point depends not only on density but also on the charge diameter, the larger the diam, the higher is the density required for reaching the maximum velocity. A similar influence is exerted by thick-walled confining containers. When using large diam chges and thick confining vessels the maximum for expl mixtures can be shifted to as far as their specific gravity. Under these conditions the type of curve $D = f(\rho)$ will be similar to those obtained for HE's not contg inert or insensitive substances. For small diam charges of expl mixtures, an increase in density might lead to a decrease in vel and also in sensitivity to initiation

Refs: 1) A. Schmidt, SS 364-69(1935); **31**, 8-13, 37-42, 80-4, 114-18, 149-53, 183-87, 218-22, 248-52, 284-88 & 322-27 (1936); CA **31**, 257-58(1937) (Deton of expls and the relation betw density & deton vel) 2) G.H. Messerly, "The Rate of Detonation of Various Explosive Compounds", OSRD **1219** (1943) 3) P. Caldirola, JChemPhys, **14**, 740(1946) (Tables giving relationships betw densities, velocity of deton, pressures- and temps- of deton for several expls 4) Taylor (1952), 88-97, 101-10, 115-28, 139-48 & 161 (Effect of densities on deton velocities) 5) C.M. Mason & F.C. Gibson, "Research Program on Detonation and Explosives Phenomena", USBurMinesProgrRept **No 10**, Oct-Dec (1955), ArmyProj 504-01-015, OrdnCorpsProj TA3-5101 6) Cook (1958), 44-5 (Equation for detm of vel vs density and Table L.1); 47 & 49 (Curves giving relationships betw densities and deton velocities of some expls) and Chap 5, pp 91-122 entitled "Detonation Wave Shape and Density Properties" 7) Dunkle's Syllabus (1957-1958), 205 & 212-15 8) Baum, Stanyukovich & Shekhter (1959), 242-45 & 289-95 (Influence of density on deton velocity) 9) Andreev & Belyaev (1960), 193-94 (Formula and table for calcg vel in relation to density); 204-06 (Influence of densities on deton velocities for some expls)

DETONATION VELOCITY-CHARGE DIAMETER AND DENSITY RELATIONSHIPS

Accd to Price (Ref 15), in studying shock-to-detonation transitions a frequent question is whether a certain expl is extremely insensitive to shock or is, in fact, nondetonable under the test conditions. To answer it, some investigation must be made of the critical diam (d_c) of cylindrical chges, i.e., that diam above which deton propagates and below which deton fails. The loading density rather than the diam can be varied; in that case, the critical density (ρ_c) is detd. Pairs of such values form the *detonability limit curve* which divides the d -vs- ρ plane into one region where deton can occur and another where it must fail. Failure of deton just below the critical diam is attributed specifically to rarefactions entering the reaction zone and quenching the reaction. Therefore, there is a close dependence

betwn the reaction-zone length and the critical diam of a given expl. Relatively less thought seems to have been given to the critical d. Its basic variable:

$$\Delta = \text{loading density/voidless density}$$

is the important one in defining the two expl groupings described by Dr Price (Ref 15)

Prior to publication of papers by Price (Ref 15) and by Gordon (Refs 13 & 14), considerable work on relationship between density, diameter and detonation velocity was done in the US by Cook's group as described in his book (Ref 6) and also in Russia by many investigators (Refs 1, 2, 3, 4, 7, 8 & 9). Some work was done in Germany by Bichel & Kast and in France by Dautriche & others. Some work done in France after WWII is described in Ref 5. More recent Rus work is described in Refs 10, 11 & 12.

Cook et al (Ref 6, pp 44-57) found that velocities in the ideal detonation of gases are much less sensitive to the initial density (designated by him as ρ_1) than in condensed explosives. Curves given in Fig 2.2 and Fig 3.3, p 47 (our figs 1 & 2) show relationships D vs ρ for HBX & Tritonal are nonlinear and D vs d (diameter) have some anomalous depressions. This was observed in 1954, but was withheld from publication until 1957, when Berger et al (Ref 5) observed in France the same phenomenon in their D vs ρ curves for mixtures of PETN and Al, $\rho_1 = 0.92$ & $\rho_1 = 0.75$

On p 48 of his book, Cook stated that from the usage of the terms *ideal* and *nonideal*, as applied to the steady-state propagation of deton waves, all expls will exhibit both types; it is necessary only to select the chge diam either as very large to observe ideal, or sufficiently small to observe nonideal deton. Transient and the (low-high) dual-velocity wave propagation are associated with nonsteady and/or unstable phenomena. Nonideal deton is, however, steady and stable under the particular conditions (chge diam and confinement) where it is observed

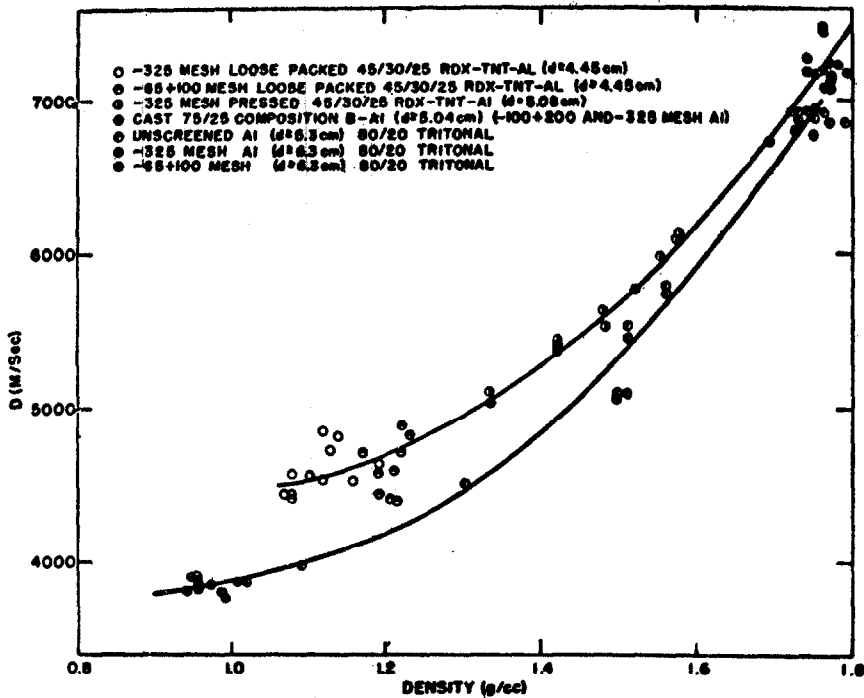

Figure 1 Velocity (D) versus density (ρ_i) curves for HBX and Tritonal

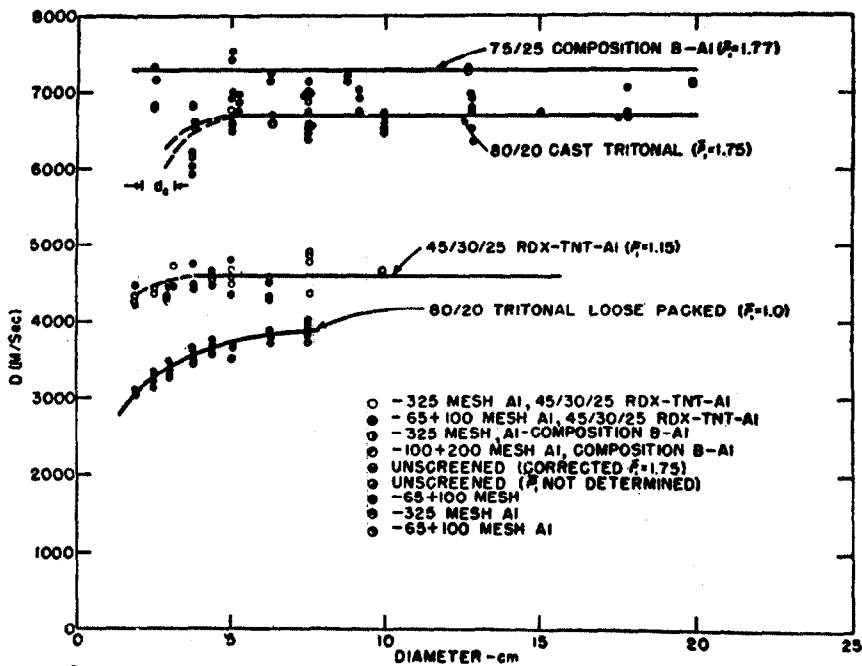

Figure 2 Velocity (D) versus diameter (d) or $D(d)$ curves for HBX and Tritonal

In cylindrical chges betw the *critical* diam d_c , below which steady deton will not propagate, and the *minimum* diam d_m^* for ideal deton, one observes in general D - d curves (See Figs 3 and 4), which increase steadily with diameter from the minimum steady vel D at d_c to maximum or hydrodynamic vel D^* at d_m^* . The ideal regime then corresponds to $d > d_m^*$. The extent of the regime of nonideal deton

$d_c < d < d_m^*$ depends on the degree of confinement and the rate of the reaction of the expls. The reaction rate depends on the physical state of the expl, primarily its density and particle size. Increased particle size in general increases both d_c and d_m^* . Increased confinement at const diam invariably increases vel in the nonideal regime and moreover lowers both d_c & d_m^*

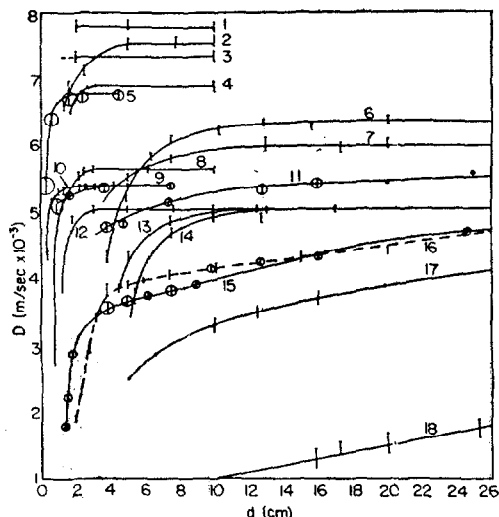

Figure 3 Velocity-diameter curves (1. Composition B ($\rho_1 = 1.70$); 2. 70.7/29.3 Composition B-AN ($\rho_1 = 1.59$); 3. 50/50 Pentolite ($\rho_1 = 1.62$); 4. TNT ("creamed", $\rho_1 = 1.6$); 5. RDX (-65 +100 mesh, $\rho_1 = 1.20$); 6. 50/50 amatol ($\rho_1 = 1.53$); 7. 50/50 sodatol ($\rho_1 = 1.83$); 8. EDNA (-35 +48 mesh, $\rho_1 = 1.0$); 9. PETN (-35 +48 mesh, $\rho_1 = 0.95$); 10. tetryl (-35 +48 mesh, $\rho_1 = 0.95$); 11. 65/35 baratol ($\rho_1 = 2.35$); 12. TNT (-65 +100 mesh, $\rho_1 = 1.0$); 13. TNT (-6 +8 mesh, $\rho_1 = 1.0$); 14. TNT (-4 +6 mesh, $\rho_1 = 1.0$); 15. 50/50 TNT-AN (-20 +30 mesh AN, $\rho_1 = 1.0$); 16. 50/50 TNT-SN (-28 +48 mesh, $\rho_1 = 1.15$); 17. 2,4 DNT (-65 +100 mesh, $\rho_1 = 0.95$); 18. AN (-65 mesh, $\rho_1 = 1.04$)

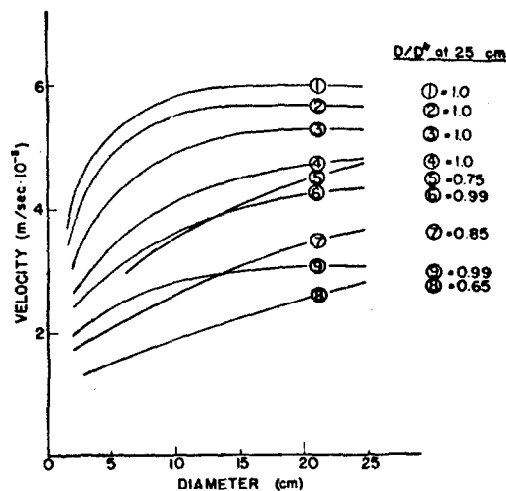

Figure 4 Velocity-diameter curves for some commercial explosives (1. 60 per cent ammonia gelatin; 2. 40 per cent ammonia gelatin; 3. 60 per cent AN-SN dynamite; 4. per cent AN-SN dynamite; 5. fuel sensitized coarse-fine AN explosive ($\rho_1 = 1.3$); 6. fine grained AN permissible ($\rho_1 = 0.8$, NG 7 per cent); 7. intermediate grained AN permissible ($\rho_1 = 0.8$, NG 7 per cent); 8. coarse grained AN permissible ($\rho_1 = 0.8$, NG 7 per cent); 9. fine grained AN permissible ($\rho_1 = 0.6$)

As was already mentioned, considerable work on relationship between charge densities, diameters and detonation velocities was done by Russian scientists. Besides investigating *critical* (kriticheskii in Rus) densities (ρ_c) & and diameters (d_c), they also determined values which they named *limiting* (predel'nyi, in Rus) density (ρ_l) and diameter (d). The names of Rus scientists who worked on these subjects until about 1960 are: Belyaev, Khariton, Bobolev, Petrovskii, Shekhter, etc, and of Polish scientist Urbański are listed in Ref 8, pp 261-67 & 283-95 and Ref 9, pp 196-210, 244-49 & 257-62

Accdg to our translation from the Russian, the *critical density* (ρ_c) may be defined as the lowest value of loading density, ρ , at which a detonation wave will propagate thru full length of expl column at steady rate. Smallest further decrease in ρ will cause *failure* of detonation. The lowest deton velocity at this point, as registered by high-speed photography, may be considered as *critical velocity* D_c and the density as *critical* ρ_c (Ref 8, pp 292-93)

The *limiting density*, ρ_l , may be defined as the lowest ρ at which deton velocity will reach its maximum value, called *limiting velocity*, D_l . For HE's like TNT, PETN, RDX, PA, etc, ρ_l corresponds to the highest density obtainable, which is usually crystal density or specific gravity. This means that relationship of density of chge, ρ , to specific gravity, designated as Δ must be ca 1.0 to achieve D_l . Relation between D & Δ for this type of expl is given in Ref 9, p 204, Fig 40.4, reproduced here as Fig 5. The curves given in this fig for PETN (TEN in Rus) & PA show that until Δ reaches ca 0.3 the increase in D is rather slow and then the curves become steeper and approach straight lines. Both curves refer to chge diameters above d_c . These are ca 1.5 mm for PETN and ca 6mm for PA

Fig 86 of Ref 8, p 290 (shown here as Fig 6) gives relation between $\log D$ and $\log \rho$ for TNT (Trotil in Rus) and RDX (Gheksoghen in Rus), phlegmatized with 5% paraffin. The work was done by Shekhter. D was detd by rotating drum camera and compared with values calcd from the formula:

$$D = B\rho_0^a$$

where $B=5060$ m/sec for TNT & 5720 for RDX; $a=0.67$ for TNT & 0.71 for RDX. Both methods gave fairly good agreement in results. Tables 65 & 66, pp 290-91 of Ref 8, give values of D 's at various initial densities, ρ_0

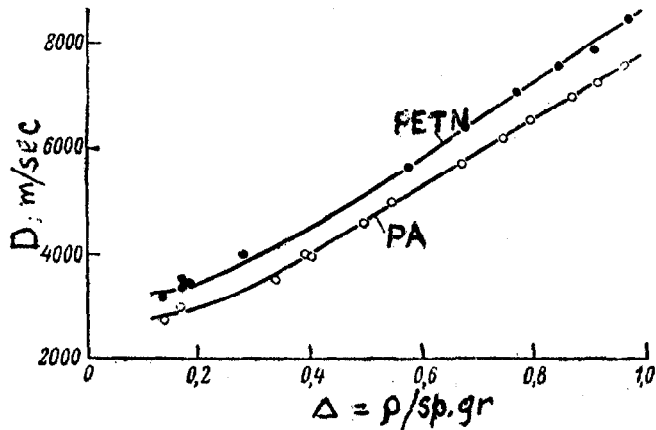

Fig 5 Relationship: Detonation Velocity (D) vs "Relative Density" A

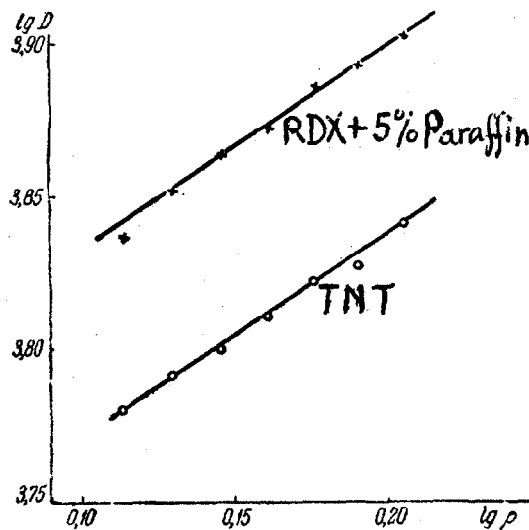

Fig 6 Relationship: Detonation Velocity vs Density of Charge

Table I

| | | | | | | | |
|-----------------------|-----------------------|------|------|------|------|------|------|
| TNT | $\rho_0, \text{g/cc}$ | 1.30 | 1.40 | 1.50 | 1.55 | 1.60 | 1.61 |
| | D, m/sec | 6025 | 6315 | 6610 | 6735 | 6960 | 7000 |
| RDX (+5% Paraffin) | ρ_0 | 1.25 | 1.35 | 1.40 | 1.50 | 1.55 | 1.60 |
| | D | 6660 | 7125 | 7315 | 7640 | 7820 | 7995 |
| PETN | ρ_0 | 1.03 | 1.22 | 1.37 | 1.50 | 1.62 | 1.73 |
| | D | 5615 | 6357 | 6970 | 7415 | 7913 | 8350 |
| Tetryl | ρ_0 | 0.52 | 0.69 | 0.96 | 1.22 | 1.42 | 1.68 |
| | D | 3940 | 4444 | 5387 | 6291 | 7373 | 7740 |
| PA | ρ_0 | 0.7 | 0.97 | 1.32 | 1.41 | 1.62 | 1.70 |
| | D | 4020 | 4963 | 6190 | 6510 | 7200 | 7483 |
| LA | ρ_0 | 1.06 | 1.18 | 2.56 | 3.51 | 3.96 | 4.05 |
| | D | 2664 | 3322 | 4478 | 4745 | 5123 | 5276 |

Investigations by Bobolev & others have shown that for single HE's increase of loading density causes decrease in d_0 and d_c and also decrease of difference between them. These values are also influenced by the particle size of chge. For example, Fig 88, p 292 of Ref 8 (our Fig 7) gives relationship betw critical diameter, d_c , and loading density, ρ_0 , for two chges of pressed TNT. Curve 1 refers to chges with particle sizes 0.2 to 0.7 mm, while curve 2 refers to sizes 0.05 to 0.01 mm. It can be seen that increase of ρ_0 from 0.85 g/cc to 1.5 causes decrease of d_c from ca 10.9 mm to ca 2.5 and decrease from 0.85 g/cc to 1.4 causes decrease from ca 4.9 to ca 1.1 mm. The same investigators found that for cast, large crystals TNT and for liquid TNT ($\rho_0 = 1.46 \text{ g/cc}$ to 100°), critical diams are of the same order (ca 31 mm). Such a high value of d_c for cast and liq TNT are due to their lower sensitivity to initiation in comparison with pressed charges

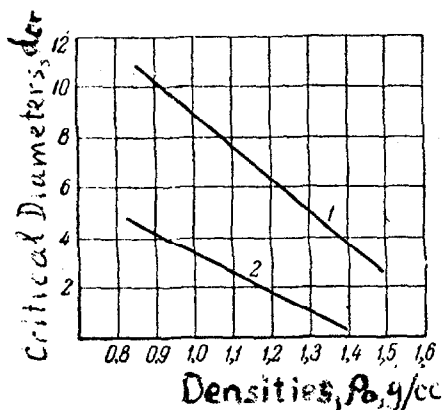

Fig 7. Relationship of Critical Diameter vs Density of Pressed TNT

Relationship for HE's (such as TNT, RDX, Amatol, etc) betw chge diameter d and detonation velocity D gives a curve which shows that in the section betw critical diam and limiting diam of d_0 , there is a steady gradual increase in D until its highest (limiting) value D_l is reached. This takes place at diameter called in Rus literature limiting, d_l . After this D does not change with the increase of diameter and the curve $d-D$ becomes a straight line parallel to abscissa as shown in Fig 8 reproduced from Ref 9, p 195. A similar curve is given on p 283 of Ref 8 and several curves shown on pp 47-9 of Cook's book (Ref 6) are velocity-diameter curves

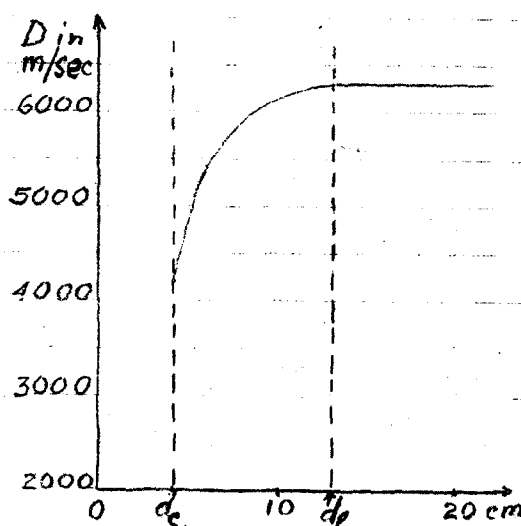

Fig 8 Relationship of Detonation Velocity and Diameter of Charge for 50/50 Amatol of Density 1.53 g/cc

If diameter of chge is larger than limiting value, the deton velocity, D_d , can be influenced only by density or by heat of explosion (Ref 8, p 289)

Sizes of critical and limiting diameters of solid expls are influenced also by particle size and by method of prepn of charge (pressing or casting). The smaller the crystals, the smaller are d_c & d_l . Fig 85 of Ref 8 gives results of experiments of Bobolev in the form of d - D curves. Curve 1 (our Fig 9) refers to TNT of particle sizes 0.2-0.07 mm and $\rho_o = 0.85$; curve 2 for TNT of particle sizes 0.05-0.01 and $\rho_o = 0.85$; curve 3 for PA of particle sizes 0.75-0.1 and $\rho_o = 0.95$; and curve 4 for PA of particle sizes much smaller

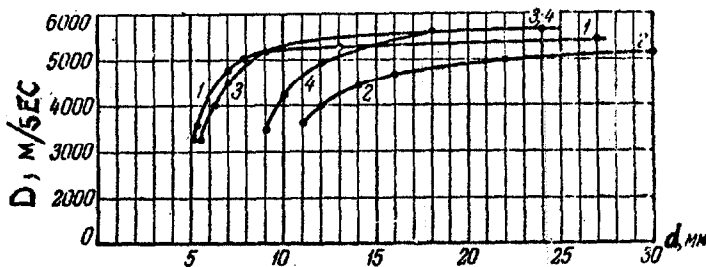

Fig 9 Influence of Diameter and Particle Size of a Charge on its Detonation Velocity

The values d_c and d_l for these expls as well as for some other expls are given in Table II which is a compilation of values given in Refs 8 & 9. Detonation velocities are not given because they are already listed in Table I. Baum et al (Ref 8, p 285) stated that critical velocities for HE's are between 2200 and 3000 m/sec

Values in Table II show that the lowest d_c and d_l are for expls of very high sensitivity (such as LA & TeNMe+NB), while the highest d_c & d_l are for very insensitive expls like AmatoIs and AN. Both d_c and d_l decrease with decrease of particle size and the difference between them becomes smaller

In detonation of weak explosives like mixtures contg large amounts of nonexplosive ingredients (such as AN, K chlorate, carbonaceous material, etc), there also are critical and limiting densities, diameters and detonation velocities, but curves of their relationships have different shapes than those for HE's

Table II

| Explosive | Density ρ_o , g/cc | Particle Size, mm | d_c , mm | d_l , mm |
|---------------|-------------------------|-------------------|------------|------------|
| TNT | 0.85 | 0.2 - 0.07 | 11.0 | 30.0 |
| TNT | 0.85 | 0.05 - 0.01 | 5.5 | 9.0 |
| TNT (Pressed) | 1.60 | ? | - | 10.0 |
| PA | 0.95 | 0.75 - 0.1 | 9.0 | 17.0 |
| PA | 0.95 | Very fine | 5.5 | 9.0 |
| NG (crysts) | 1.00 | 0.4 | 2.0 | 3-4 |
| RDX | 1.00 | 0.15 - 0.025 | 1.2 | 3-4 |
| PETN | 1.00 | 0.1 - 0.025 | 0.9 | - |
| 50/50-Amatol | 0.85 | Cast | 10.0 | 120 |
| AN | 0.75 | - | 80-100 | - |
| LA | ca 4.0 | - | 0.02 | 0.4 |
| TeNMe+NB | - | - | 0.05 | - |

In examining relationship between ρ and D for expls like Cheddite, Dinamon, some AmatoIs, etc, it was observed that D increased with ρ_o until it reached a certain maximum and then it started to decrease. The max value of D is influenced by the diam of chge - the larger the diam, the higher the density at which maximum is reached. Confinement of chge has a similar effect on D_d . Dautriche determined this relationship for Cheddite of chge diams 20 & 40 mm, and his curves are given in Fig 87, p 291 of Ref 8 and Fig 4.41, p 205 of Ref 9 (Our Fig 10)

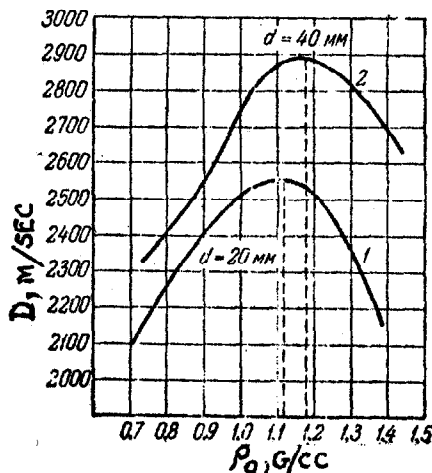

Fig 10 Detonation Velocity vs Density of Cheddite

The same type of relationship was independently observed by Cook for 90/10-AN/DNT and 90/10-AN/Al mixts. His Fig 3.6 given on p 49 of Ref 6 is also shown here as Fig 11

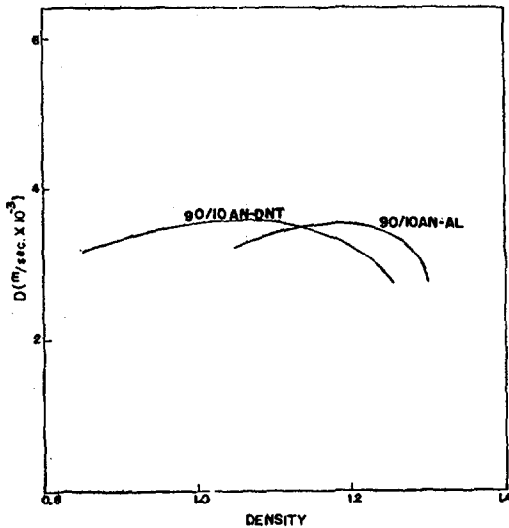

Figure 11. Typical velocity-density curves for AN-combustible mixtures in small diameter (-65 + 100 mesh AN; $d = 10$ cm)

Belyaev observed (Ref 8, p 293) that for weaker expls, such as mixts contg AN, the relationship betw critical diameter d_c and loading density ρ_0 does not resemble that given for TNT in Fig 88 (Our Fig 7). In most of these expls critical diameter increases with increase of density, as can be seen from Fig 89, p 294 of Ref 8 (Our Fig 12), where curve 1 is for Dinamon (AN 88 & peat 12%)

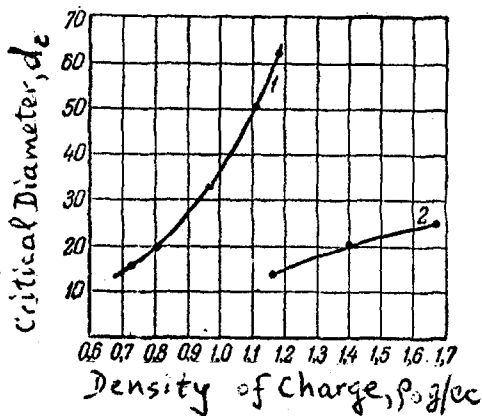

Fig 12. Critical Diameter vs Density of Charge

and curve 2 for 80/20-AN/TNT. Expls of intermediate strength, such as 50/50-Amatol (shown in Fig 90, p 294 of Ref 8 (Our Fig 13)), behave at low densities like weak expls (d_c increases with ρ_0), while at high densities they act like HE's (d_c decreases with ρ_0). The dotted line indicates the region of failure of detonation

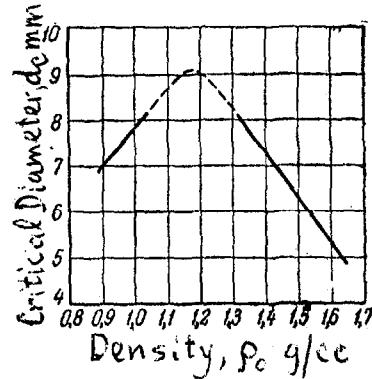

Fig 13. Critical Diameter vs Density of 50/50 Amatol

If a $D-\rho_0$ curve for an expl mixture exhibits a peak for D at charge diameters, say 20mm, it might give at higher diams a curve which levels off when $D_{\bar{c}}$ is reached. This was shown by Petrovskii for 90/10-AN/TNT mixture, whose curves are given in Fig 92, p 295 of Ref 8 (Our Fig 14). Here the curve for chge diam 23 mm is similar to those given by Dautriche for Cheddites, while the curve for chge diam 40 mm is different

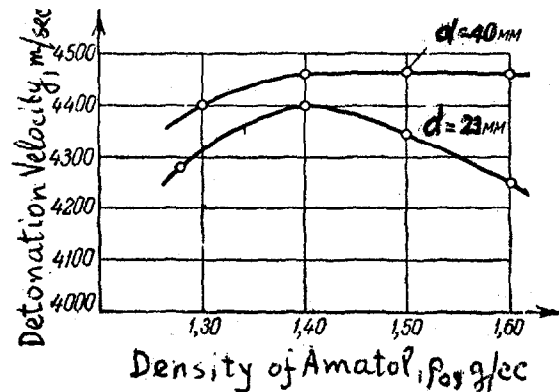

Fig 14. Detonation Velocity vs Density of Charge for 50/50 Amatol

In the book of Andreyev & Belyayev (Ref 9, p 197-98) are given critical diameters of some explosives. See Tables III & IV

Table III

Critical Diameters of Some Powdery Explosives
(Confined in glass tubes at densities 0.9–1.0 and particle sizes 0.05–0.2mm. Initiation was by means of No 8 detonator and booster)

| Explosive | Critical diam, mm |
|--------------|-------------------|
| Lead Azide | 0.01–0.02 |
| PETN | 1.0 –1.5 |
| RDX | 1.0 –1.5 |
| Lead Picrate | 2–3 |
| Picric Acid | 6 |
| TNT | 8–10 |
| 79/21-AN/TNT | 10–12 |
| 80/20-AN/Al | 12 |
| 90/10-AN/TNT | 15 |
| AN | 100 |

Table IV

Critical Diameters of Some Liquid Explosives

| Explosive | Critical diam, mm |
|--|-------------------|
| 87.5/12.5-TeNMe/NBz | <0.1 |
| 72/28-HNO ₃ /NBz | 0.5 |
| NG | 2.0 |
| 70/30-HNO ₃ /CH ₃ OH (HNO ₃ is 70% strength) | >10 |
| Liquid TNT at 80° | 62 |
| Liquid TNT at 240° | 6.0 |

Results of work of Russian investigators have also shown the following:

- Particle sizes do not affect the limiting value of D at given ρ_0 but only influence the time which is required for reaching the limiting D_q with increase of d_q .
- Critical detonation velocity, D_c , at given density is not influenced by particle size
- The above rules are valid not only for single HE's, but also for mixtures contg insensitive ingredients such as AN. For these expls, critical (and especially limiting) diameters are very high. In many cases diameters of charges used in boreholes are smaller than d_q , which means that their deton vel might be below its maximum value. For example, Belyaev found

that thoroughly pulverized Dinamon contg 88% AN & 12% peat of chge diam 80mm still did not reach d_q and its D was below the maximum value (Ref 8, p 286). It was also found by Belyayev & Belyayeva (Ref 2) that increasing the diam of the AN/Peat flour chge from 11 to 62.5mm increased the critical density from 0.7 to 1.22mm, depending on the fineness of grinding

d) Accdg to Baum et al (Ref 8, p 287), influence of confining wall on deton velocity consists of limiting the penetration of lateral rarefaction waves into zone of transformation, thus promoting more complete utilization of chemical reaction energy in detonation wave. This means that the influence on propagation of detonation is greater in expls of slower-proceeding reactions (such as in mixts contg AN) than in brisant expls (such as TNT, PETN & RDX). The smallest influence of confinement is for initiating expls and for brisant expls of high density and large diameter of chge

Investigations of Belyaev, Bobolev and others have also shown the following:

- Confining wall of greatest possible strength is not capable of increasing deton vel if diameter of chge is larger than limiting diam, $d > d_q$.
- Confining wall of any strength has practically no influence on the critical deton velocity of a charge at fixed density
- Confined chges have smaller critical and limiting diameters than corresponding unconfined chges and the stronger the inertial resistance of confining wall, the smaller are the diameters

Most of this section on relationships between charge densities, charge diameters and detonation velocities was compiled using the reports and papers listed in CA up to 1961. Mr C.G. Dunkle reviewed the manuscript and provided the comments (Ref 16) which we are giving below:

"I am not familiar with the distinction noted between critical and limiting densities. It would appear from the article by Donna Price (Ref 15), however, that some explosives have a 'critical loading density' (her term) *below* which detonation will fail, while another class of explosives has a 'critical loading density' *above* which detonation fails

For the first class (Group 1) the critical diameter decreases with increasing charge ρ .

For the second class (Group 2) the critical diameter *increases* with increasing ρ

Group 1 explosives seem to have no maximum value above which detonation fails. Group 2 explosives, which have to be below a certain critical density in order to detonate, do not, on the other hand, seem to detonate below about 50% of the theoretical maximum density. Detonation velocity vs density curves for two explosives of this type are given in Fig 3.6 on p 49 of Cook's (Ref 6). The data of both Price (her Fig 4) and Cook (his p 49) agree that as charge diameter increases, such curves approach more closely the ideal curve

The lowest charge densities at which detonation velocities are measured are 0.5–0.6 g/cc. As noted by Stesik and Shvedova (Ref 12), specific difficulties are encountered with the majority of explosives when the detonation velocity is determined at lower densities"

Mr. Dunkle also stated that he is not familiar with the term "limiting diameter", but "There is a critical minimum value d_c which the diameter of a cylindrical charge must at least equal if a steady-state detonation is to be maintained along the axis. There is also a larger critical minimum value d_m which the diameter of the charge must at least equal if the detonation is to proceed at the ideal rate. In a charge of this diameter the detonation velocity thruout is controlled by that of the *ideal* process, which occurs along the charge axis under the confining influence of the detonation in the outer layers. Once the ideal process has been achieved, further increases in diameter and confinement have no effect on the detonation velocity. It can therefore be considered to correspond to 'infinite confinement'

In diameters within the range between d_c and d_m , the velocity is highly sensitive to diameter at lower densities and/or coarser granulations. The latter increase d_m but, unlike lower densities, do not lower the ideal detonation velocity. Decrease in particle size, increase in confinement, and rise in charge density, decrease both d_m and d_c ; for TNT of high density and fine granulation, d_m can be as small as 3.0 cm and d_c as small as 0.7 cm (See Fig 3.4 on p 48 of Cook's book")

He also stated that on critical diameters of liquid expls he has just a fragment of information, namely

"The critical diameter in Nitromethane (NMe)-acetone mixtures (confined by a cylinder of thin cellophane) depends strongly on the concentration of acetone; for pure NMe, d_c is 18mm, for 92/8-NMe/acetone it is 25 mm; for 84/16-NMe/acetone it is 90mm. Extrapolation of these data gives, for 75/25-NMe/acetone, $d_c > 250$ mm

In photographs of these detonations observed from the end of the charge, heterogeneities of the glow were observed. The size of these heterogeneities decreased asymptotically to a constant value as the charge diameter increased. For this reason, and because the detonation velocity does not depend on the diameter, the detonation parameters reach values at d_c corresponding as closely as desired to infinite diameter. Thus the method of determining d_c by its transition from a narrow tube to a wide one has the advantage that by this means d_c is a parameter of the substance and does not depend on the confinement (Ref 10)"

(See also Critical Diameters of Liquid Explosives and Critical Diameter of Solid Explosives in Section 1)

Experimental Procedures. For determination of critical and limiting densities and diameters, the method described in Ref 8, pp 277-79 & Ref 9, pp 196-97 can be used. As the method is practically identical with that used for determination of "Critical Length of Propagation of Detonation" given in Section 1, it is not necessary to repeat its description

For determination of critical and limiting detonation velocities, use one of the methods described in Vo. 3 of Encycl under "CHRONOGRAPHS (Dautriche Method, pp C311-12; Mettegang Method, pp C312-13; Pin Chronograph or Pin Machine, pp C313-15; and Chronographic Method Employing Microwave Technique, pp C315-16) or one of the methods described in Vol 2 under "CAMERAS, HIGH-SPEED, PHOTOGRAPHIC" [Drum Cameras, such as rotating drum camera with moving film", "rotating (or spinning) mirror camera" and "rotating prism camera", p C14]. An oscillographic method is described in Ref 9, p 218-22

Critical diameter-critical density relationship for composite explosives given by Gordon in Ref 13, pp 837-38 is abstracted in this Vol under "Detonation Limits in Composite Explosives", Critical diameter-critical density relationship in condensed explosives, given by Gordon in Ref 14, pp 180-85 & 193-96 is abstracted in this Vol under "Detonation Limits in Condensed Explosives". The résumé of paper by Price (Ref 15) is given in this Vol under the title "Contrasting Patterns in the Behavior of High Explosives"

Refs: 1) V. Rosing & Yu.B. Khariton, Dokl AkadN **26**, 360 (1939) (The detonation cutoff of explosives when the charge diameters are small) 2) A.F. Belyaev & A.E. Belyaeva, Dokl Akad, Dokl AkadN **50**, 295-97 (1945) & CA **44**, 10321 (1950) [On the connection between limiting (maximum) density of explosive and size of charge diameter] [Engl transl JPRS-7524 (1961), distributed by Office of Technical Services, Washington 25, DC] 3) V.K. Bobolev, Dokl AkadN **57**, 789 (1947) (On the limiting diameters of chemically uniform expl chges) 4) R.Kh. Kurbangalina, ZhFizKhim **22**, 49 (1948) (The limiting diameters for stable detonation of hydrogen-peroxide-methyl alcohol and perchloric acid-ethyl alcohol mixtures) 5) J. Berger, A. Cachin & J. Viard, CR **245**, 139-41 (1957) ("Mécanique des Explosifs-Vitesse de Détonation dans un Explosif Renfermant de la Poudre d'Aluminium") 6) Cook (1958), pp 48 & 129 (Critical diameter, d_c); 48 (Minimum diameter for ideal detonation, d_m^*); 91 & 98 (Effective diameter d^* , which is equal to chge diam, d , minus 0.6 cm, where 0.6 cm represents an edge effect for unconfined charge) 7) L.N. Stesik & L.N. Akimova, ZhFizKhim **33**(8) 148 (1959) (Determination of detonation limits for TNT, PETN and Ammonium Perchlorate and Nitrate mixtures with organic fuels) 8) Baum, Stanyukovich & Shekhter (1959), 264-67 (Definition of critical and limiting diameters and critical and limiting detonation velocities); 283-84 (Relationships between detonation velocity and critical & limiting diameters); 284-85 (Relationships between critical & limiting diameters and composition of expl mixtures); 285-86 (Relationships between diameters and particle size); 287-89 (Influence of confining medium on limiting detonation velocity and limiting & critical diameters); 289-95 (Influence

of critical & limiting densities on velocity and limits of stability of detonation); 300 (Calculation of critical and limiting diameters in the process of birth and propagation of chemical reaction on the front of detonation wave) 9) Andreev & Belyaev (1960), p 195 (Definition of limiting and critical diameters); 196-201 (Dependence of critical diameter on various factors, such as chemical composition, state of aggregation, density of charge, particle size and degree of confinement); 201-10 (Dependence of detonation velocity on charge diameter particle size, degree of confinement, admixture of inert substances and initial temperature); 244-49 (Dependence of detonation pressure of condensed expls on density of charge); 257-62 [Influence of various factors (including charge diameter, etc) on birth and propagation of detonation] 10) A.N. Dremine et al, ZhPrikl i TekhnFiz **No 1**, 130-32 (1963) (Detonation mechanism in liquid expls) (English translation by US Air Force Systems Command: DDC-AD434956) 11) A.N. Dremine & K.K. Shvedov, ZhPrikl i TekhnFiz **No 2**, 154 (1964) (Expls like RDX exhibited the trend of decreasing critical diameter, d_c with increasing Δ , where Δ = loading density voidless density) 12) L.N. Stesik & N.S. Shvedova, ZhPrikl i TekhnFiz **No 4**, 124-26 (1964) (Detonation of condensed expls at low chge densities) 13) W.E. Gordon, "Detonation Limits in Composite Explosives", 10th Symp Combstn (1964), 833-38 13a) Mary L. Pandow et al, "Studies of the Diameter Dependence of Detonation Velocity in Solid Composite Propellants - I. Attempts to Calculate Reaction-Zone Thickness", 4th ONRSymp Deton (1965), 96-101 13b) Ibid, "II. Prediction of Failure Diameters", pp 102-06 14) W.E. Gordon, "Detonation Limits in Condensed Explosives", 4th ONRSymp Deton (1965), 179-97 15) Donna Price, "Contrasting Patterns in the Behavior of High Explosives", 11th Symp Combstn (1967), p 693 (Definition of critical, loading and voidless densities); 694-97 (Densities, diameters and other variables affecting detonability); 698 & 700-01 (Discussion of previous work done by various investigators listed in 20 refs); 702 (Comments by Drs J.H. Wiegand, D. Price & L.B. Seely) 15a) D. Price et al, "Explosive Behavior of Ammonium Perchlorate", Combustion & Flame **11**, 415-25 (Oct 1967) 16) C.G. Dunkle, private communication, Dec 1967

Detonation Velocity-Charge Length Relationship.
See under Critical Length of Propagation of Detonation, Section 1, and in Cook (1958), pp 52, 54-9 & 128

Detonation Velocity and Chemical Composition and Detonation Velocity as a Function of Oxygen Balance and Heat of Formation.

Under this title, Martin & Yallop describe (Ref 1) their investigation of this relationship. They established a simple, semi-empirical relation between detonation velocity of organic expls in their liquid, cast or compressed condition with their oxygen balance and density of charge. Their experiments have shown that, at given densities, deton velocities of organic HE's with negative oxygen balances, depend linearly on them, if OB is considered to be at optimum value when it is equal to zero. This is not surprising, because energy evolved on detonation and composition of products of deton are dependent on the value of oxygen balance

Martin & Yallop consider that the usual method of calcn of OB (See Vol 1 of Encycl, p A515-L) is not satisfactory because it does not take into consideration that oxygen atoms of nitrogroups in molecules of organic expls are not equivalent from the point of view of energetics to O atoms of CO and COH groups. This defect is claimed as being eliminated if the following equation for oxygen balance, Ω , is used:

$$\Omega = \frac{(z - 2x - 0.5y) \times 100}{n} + \frac{100w}{n} \quad (\text{Eq 1})$$

where z, x, y are numbers of oxygen, carbon and hydrogen atoms, respectively, in the molecule; n = total number of atoms in molecule; and w is a correction factor. This factor is calculated by summing the oxygen atoms according to their linkages: 1) Zero for oxygen atoms in $-N=O$; 2) 1.0 for oxygen in $\geq C-O-N$; 3) 2.0 for oxygen in $\geq C=O$; and 4) 2.0 for oxygen in $\geq C-OH$

The sign in front of $100w/n$ must be the same as for that of first term in equation 1

If OB is calcd by this method, deton vel may be calcd for expls of ρ ca 1.6 g/cc, using the equation:

$$D = 8578 + 33.74\Omega \quad (\text{Eq 2})$$

For other than 1.6 density the following eq was proposed:

$$D = 2509 + 13.25\Omega + 3793\rho + 12.81\Omega\rho \quad (\text{Eq 3})$$

More exact results are obt'd when *heat of formation*, H, is taken into consideration, as shown in the eq:

$$D = 2590 + 11.97\Omega_1 - 0.706H + 3764\rho + 13.67\rho\Omega_1 + 0.108\rho H \quad (\text{Eq 4})$$

In this eq oxygen balance Ω_1 is calcd using the following coefficients for oxygen atoms: Zero for O in $-N=O$ group, 0.5 for O in $\geq C-O-N$ and 1 for $\geq C-O-H$ group

If heat of formation H, is not known, it can be calcd from heat of explosion and composition of products of explosion if they are known. [See also Table 8 under DETONATION (EXPLOSION AND DEFLAGRATION) VELOCITY]

Dr Donna Price (Ref 2) prepd a critical review of the paper by Martin & Yallop and showed that available data for six or more expls contradicted the predictions of deton velocities within 2%, and that the working assumption's used were theoretically unsound. Accordg to Price, a general consideration of the concept of oxygen balance for an org expl pointed out that, while the quantity is, by definition, directly proportional to the amt of addnl oxygen reqd to burn the deton products completely, it yields no info about deton energy. In the special case in which the deton products contain only one fuel, the addnl energy from post-deton oxidation of the products is directly proportional to OB. In general, however, OB yields no quantitative info about this addnl energy which is the diff between the heats of combstn and of deton

Oxygen balance can be defined and computed exactly for a material, $C_aH_bN_cO_d$ by:

$$OB (CO_2), \% = \frac{(d - 2a - \frac{1}{2}b) 1600}{MW} \quad (\text{Eq 5})$$

$$\text{and } OB (CO), \% = \frac{(d - a - \frac{1}{2}b) 1600}{MW} \quad (\text{Eq 6})$$

$$= OB \text{ to } CO_2 + \frac{a}{MW} (1600)$$

In Part II of their study, Martin & Yallop introduced the heat of formation of the expl as a third parameter, and assumed the deton vel linearly dependent on Ω & H_f (heat of formation),

and ρ_0 (loading density in g/cc). The resulting general equation (Eq 4 above) was tested by Price with available data and found to be neither better nor worse than the agreement found with Eq 2 & Eq 3, above. Price found the fundamental objections to the first part of the paper to be equally applicable to the second part

Refs: 1) A.R. Martin & H.J. Yallop, "Some Aspects of Detonation: Part 1. Detonation Velocity and Chemical Composition. Part 2. Detonation Velocity as a Function of Oxygen Balance and Heat of Formation", *TrFaradSoc* **54**, 257-67 (1958) 2) D. Price, "A Review of a Paper by Martin & Yallop and a General Discussion of Oxygen Balance of Explosives", NAVORD Rept **6651** (20 May 1959) 3) Andreev & Belyaev (1960), pp 193-95 (Résumé of paper by Martin & Yallop)

Detonation Velocity-Confinement and Obturation Relationship. Accdg to W.G. Penney (as quoted by Dunkle, Ref 8, p 209), deton rate of condensed phase expls is related to charge diam in the same way as confinement. The two relationships are equivalent, because the outer portions of a detonating chge give effective confinement to the central region

Accdg to Dunkle (Ref 8, p 206), confinement and obturation of expls in rigid tubes leads to an increase in deton velocity and this has been explained by various investigators on the basis of the hydrodynamic theory of detonation

Accdg to Penney (Ref 3, p 15, as quoted in Ref 8, p 208), the strength of confining tube has little or no influence, the main factors being the density (or its inertial effect) for a thin wall and compressibility for a thick wall. Thus, accdg to Deffet & Boucart (Ref 7, p 642, as quoted in Ref 8, p 208), a 1-mm thick lead tube increases the deton vel more than a steel one of the same thickness, whereas the opposite is true if the thickness of the tubes exceeds a few mm. The lead in thick confinement is the less effective metal despite its high sp gr, for its higher compressibility allows more expansion in the region of the reaction zone and thus leads to an effective lowering of the pressure in that region. The lowering is reflected in a reduction of the velocity of propagation. Confinement is considered "thick" if the time

required for the shock wave to traverse the wall is no longer than the reaction time

Kistiakowsky (Ref 1, p 563, as quoted in Ref 8, p 208) concluded from experiments of S.J. Jacobs that when deflagration is uniform thruout a mass of expl filling all the available space, confinement itself is not conducive to deton, but confinement definitely favors the change-over into deton in cases when deflagration is non-uniform. The confinement encourages transition to detonation because the more rapidly rising pressures accelerate deflgrn and favor the formation of shock waves. The reflection of the waves by the confining vessel with attendant pressure amplification, may be an important factor, just as it is a contributing cause for "combustion knock" (qv)

Kistiakowsky & Zinman (Ref 4, p 87, as quoted in Ref 8, p 209) found that velocities of plane deton waves in gaseous mixts confined in straight tubes fall off with decrease in tube diam. The same effect was observed by Edwards & Williams (Ref 5, as quoted in Ref 8, p 209) who offered evidence that it is due to rarefaction waves which form at the tube wall and travel inward at sonic velocity, lowering the temp, the chemical reaction and, in some cases, the deton pressure

Deton vel of condensed-phase expls is related to chge diam in the same way as to confinement (Ref 3, p 15, as quoted in Ref 8, p 209). The two relationships are equivalent, because the outer portions of a detonating chge give effective confinement to the central region. There is a "critical minimum diameter" (Ref 6, as quoted in Ref 8, p 209) which must be at least equalled if an unconfined cylindrical chge is to detonate completely when initiated at one end. The other critical minimum diam, which must be at least equalled to give deton at theoretical maximum or "ideal" rate, may be still larger

Combined influence of charge diameter and confinement were evaluated by H. Eyring et al (Ref 2, as quoted in Ref 8, p 210) in an extensive comparison of their "curved front" theory of deton zone structure with the "nozzle" theory of H. Jones

Cook (Ref 9, p 99) stated that influence of confinement on the total end effect has been investigated only over limited ranges of chge

diam. In the range of diams betw 1.5 & 2.0 inches, exptl results indicate that the maximum effective confinement obtainable with steel is reached with a tube of ca 0.5 inch in thickness. Also, it was found that with max confinement the effective chge length L_m in this range of diameters increased only ca one chge diam above that with unconfined chges, while the total end effect about doubled. This means that the steady-state, effective detonation-head mass increased by a factor of about two, while its axial length increased only 1/3 in this range of diams by increasing from 0 to maximum effective confinement

Accdg to Baum et al (Ref 10), the walls of confining container restrict the penetration of side waves of rarefaction into zone of transformation and this helps to utilize more fully the energy of chemical reaction in the deton wave. This leads to increase in deton vel and the influence of confinement is greater for expls of low velocity (such as AN expls) than for brisant expls like RDX, PETN, etc. The influence is the lowest for initiating expls, such as MF or LA. For brisant expls the influence of confinement is noticeable only at small diams and low densities of charges

Accdg to investigations of Belyaev, Bobolev and other investigators (quoted from Ref 10, p 288) in Russia, the following conclusions were reached:

- 1) Confining vessel, even with the walls of highest strength cannot increase the deton vel of an expl if the diam of charge is larger than *limiting* (predel'nyi, in Rus)
- 2) If an expl is properly initiated, its *critical* deton vel at a certain density is not noticeably influenced by confinement
- 3) Confined charges have smaller *critical* and *limiting* diameters than unconfined chges and the stronger the inertial resistance of confining walls, the smaller are these diameters
- 4) The higher the sp gr of material of the wall, the greater is the influence of confinement
- 5) For expls of low brisance the strength of confining wall is of importance
- 6) The confinement acts for low brisance expl chges in the same manner as the increase of chge diam and if diam of an unconfined chge is sufficiently large, the velocity is as high as that for a confined chge of smaller diam. For

example, when an 88/12-AN/TNT expl chge of density 0.85 and of diam 5 mm was detonated under water confinement the velocity of 1650 m/sec was developed. The same expl, when unconfined, did not develop this vel until its chge diam was increased to 16-17 mm

Table 1 gives critical diameters of various AN/TNT expl mixts for unconfined and confined chges in water

Table 1

| Compn of Mixture | | Critical Diameter, mm | |
|------------------|-------|-----------------------|------------|
| % AN | % TNT | Confined | Unconfined |
| 0 | 100 | -- | 9 |
| 72 | 22 | 4 | 12 |
| 88 | 12 | 5 | 15 |
| 94 | 6 | 8 | 21 |
| 97 | 3 | 14 | 30 |
| 100 | 0 | 40 | 100 |

The thickness of water confinement was 3-4 diams of charge and density of chge 0.8-0.85g/cc

Belyaev et al also found that if a steel tube with wall thickness of 2 mm was used for confining the chge of straight AN at d 0.7-0.8, its critical diam could be reduced from 80-100 mm to 7 mm and there would still be obtd a steady deton at velocity of ca 1500 m/sec. Expls of very high sensitivity have usually very small critical diams as, for example, the mixt of TeNMe & NBz, which has, accdg to Gol'binder $d_{cr} = 0.05$ mm. LA has, accdg to Bowden, (at density near max) the critical diam of crystals d_{cr} , ca 20 microns, while its limiting diam, d_{lim} is ca 400 microns. The corresponding deton vels are 2000 & 5000 m/sec. At diam smaller than critical LA does not deton but only decomposes

Critical diams of brisant HE's are considerably smaller than of expl mixts contg insensitive components, such as AN (See Table 1)

Table 2 compiled from data of Bobolev, on pp 285 & 286 of Ref 10, gives critical and some limiting diams for pure HE's

Table 2

| Explosive | Density g/cc | Particle sizes, mm | Diameter critical, mm | Diameter limiting, mm |
|-----------|-----------------|--------------------------|-----------------------------|-----------------------------|
| TNT | 0.85 | 0.2-0.07 | 11.0 | 30.0 |
| " | 0.85 | 0.05-0.01 | 5.5 | 9.0 |
| PA | 0.95 | 0.75-0.1 | 9.0 | 17.0 |
| " | 0.95 | Fine crysts | 5.5 | 11.0 |
| NG(solid) | 1.00 | 0.4 | 2.0 | ? |
| RDX | 1.00 | 0.15-0.025 | 1.2 | ? |
| PETN | 1.00 | 0.1-0.025 | 0.9 | ? |

Andreev & Belyaev (Ref 11) presented data which confirms essentially the information given in Ref 10. They also stated that influence of confinement is the

greatest at intermediate densities of charges, it is smaller at lower densities and is practically absent at high densities. In regard to materials of confining vessels, they think that the stronger the walls and the higher their sp gravity, the more influence they exert on chges of pure brisant HE's, provided diams of chges are below the limiting valves. For diams above limiting ones, the kind of confinement has no influence

Table 3, taken from data on pp 203-04 of Ref 11, gives relationship betw deton velocity, material of confining vessel, thickness of wall and chge density for some pure HE's

Table 3

| Explosive | Material of wall | Diameter of chge, mm | Thickness of wall, mm | Charge density g/cc | Deton vel, m/sec |
|-------------------|------------------------|----------------------------|-----------------------------|---------------------------|------------------------|
| TNT(pdr) | Glass | 25 | 1 | 0.250 | 2363 |
| " | Steel | 27 | 4 | 0.250 | 2478 |
| " | Glass | 16 | 0.8 | 0.832 | 3308 |
| " | Copper | 15 | 1 | 0.832 | 4100 |
| Tetryl | Paper | 5 | 0.08 | 0.240 | 2605 |
| " | Glass | 5 | 1 | 0.240 | 2900 |
| PETN | Glass | 16 | 0.8 | 0.300 | 3419 |
| " | Copper | 15 | 1 | 0.300 | 3548 |
| Methyl Nitrate | Glass | 3 | 1 | - | 1900 |
| " | " | 3 | 2 | - | 2200 |
| " | " | 3 | 4.5 | - | 2480 |
| TNT(cast) | Steel | 21 | 3 | 1.6 | 6650 |
| " | " | 29 | 10 | 1.6 | 6700 |
| " | " | 160 | 25 | 1.6 | 6690 |
| " | " | 300 | 50 | 1.6 | 6710 |
| Tetryl | Copper | 7 | 0.23 | 1.69 | 7622 |
| " | " | 21 | 2 | 1.69 | 7625 |

Refs: 1) G. B. Kistiakowsky, p 563 in the 3rd Symp Combstn (1949)
 2) H. Eyring et al, Chem Revs 45, 156-59 (1949) 3) W.G. Penney et al, Pr Roy Soc 204A 15 (1950)
 3a) Taylor (1952), 131-40 & 144-48 (Effect of confinement on deton velocity)

4) G.B. Kistiakowsky & W.G.Zinman, p87 in the 2nd ONR Symp Deton (1955)
 5) D.H.Edwards & G.T. Williams, Nature 180, 1117 (1957) 6) G.J. Horvat & E.G. Murray, Pic Arsn SFAL-Tech Rept 2389 (1957) 6a) J.E. Bubser, "Investigation of the Effects of Confinement on

Stab-Type Detonators", Atlas Powder Co, Final Rept Apr 1957, Contract DAI-28 017-ORD-(P)-1207 (Conf) (Not used as a source of info) 7) L. Deffet & J. Boucart, p 642 in the 6th Symp Combstn (1957) (Influence of confinement on deton velocity) 8) Dunkle's Syllabus (1958), 206-10 (See in the text) 9) Cook (1958), (See in the text) 10) Baum, Stanyukovich & Shekhter (1959), 287-89 (Influence of materials of confining vessel on deton velocity) 11) Andreev & Belyaev (1960), 203-04 (Influence of material of confining vessel on deton velocity)

Detonation Velocity-Critical and Limiting Diameter Relationships

Critical diameter is the minimum diameter at which a steady regime of detonation is possible for an explosive-charge properly initiated. This diameter is influenced by density of charge, its degree of confinement, particle size distribution, and some other factors

A steady high-order velocity of detonation reaches its lowest value at critical diam and is known as *critical detonation velocity*. Below the critical diam value of charge there is either failure or so-called "low-regime of detonation" which usually does not proceed at steady state

With an increase of charge diameter, velocity increases until it reaches a certain limiting value and either remains steady or starts to decrease. This diameter is known as *limiting diameter* (predel'nyi in Rus) and the corresponding velocity is called *limiting (or maximum velocity of detonation)*

For determination of critical diameters, the tests described under Detonation Velocity-Charge Diameter and Density Relationships, Experimental Procedures can be used

Refs: 1) Baum, Stanyukovich & Shekhter (1959), pp 283-98 2) Andreev & Belyaev (1960), pp 193-210

Detonation Velocity, Critical and Limiting. Their definitions are given under Detonation Velocity-Critical and Limiting Diameter Relationships

Detonation Velocity-Crystal Size Relationship. See under Detonation Velocity - Particle Size Distribution Relationship

Detonation Velocity-Density of Charge Relationship. See Detonation Velocity-Charge Density Relationship

Detonation Velocity-Diameter of charge Relationship. See Detonation Velocity; Charge Diameter Relationship

Detonation Velocity by Direct Visualization of the Explosive Flow.

Fauquignon et al stated in "Introduction (Ref 12, p39), that most of the experimental methods concern velocity measurements in an inert medium close to the explosive, eg: a) Free-surface velocity imparted to metallic plates of increasing thicknesses (Refs 2, 5, 6, 10, & 11); b) Water or Plexiglas induced shock wave velocity (Refs 8 & 9) (See Detonation, Water or Plexiglas Induced Shock Wave Velocity Method) c) Method based on the metallic transition of sulfur (Ref 7 (See Detonation Velocity by Metallic Transition of Sulfur Method

One of the interesting features of these methods is that they give an enlarged picture of the reaction zone; however distortions, particularly those due to expl reflected waves may be expected

The method described by Fauquignon et al uses a *direct visualization of the explosive flow*, similar to that

described by Clark (Ref 1) and by Viard (Ref 3). It consisted in following the displacement of several gold foils, 0.01mm thick, glued betw cylindrical sections 20 or 30 mm diam and 6mm thick. The 1st long section was used to establish a permanent

flow. These sections comprised part of a long cast cylindrical charge of 85/15 - RDX/TNT [which was called by Berger et al (Ref 8a) *Explosif D*] of density 1.62 g/cc. Experimental arrangement is shown in Fig 1

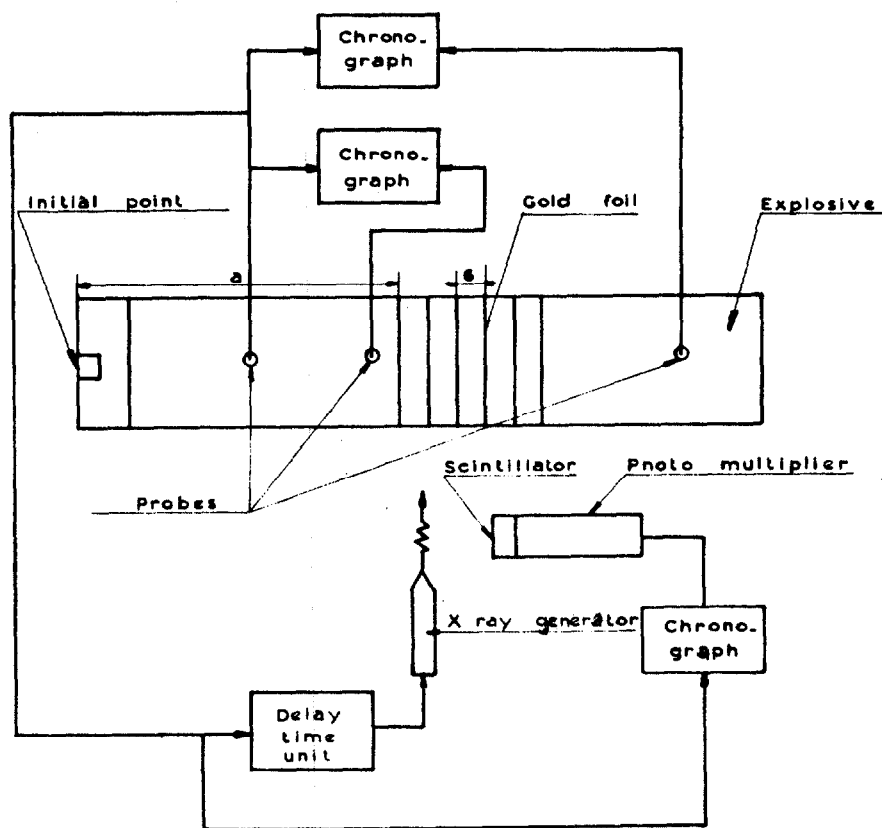

Fig 1 - Experimental arrangement

During the passage of the shock front, the foils were carried along by the products of detonation. The radiographic observation of their position at different known instants allowed the construction of their path versus time diagram

A 300-Kvolt X-ray FEXITRON unit was used, the flash duration being $0.12\mu\text{sec}$ and the optical magnification 1.1. Ionization probes placed on the axis of the chge were

used for time measurements and X-ray flash synchronization. The 1st probe located betw the initiation point and the observation area was used as a time origin; it triggered three ROCHAR chronographs, and, thru a delay unit, the X-ray flash. Two of the chronographs were used for deton velocity measurements; the 3rd one was stopped by the impulse coming from the scintillator-photo-multiplier and established

correlation betw the picture time and the instant of passage of the shock front at the 1st ionization probe. The displacement of the foils was referred either to their initial positions or to a position of another foil which has not yet been reached by the shock at the time of radiography. Fig 2 of Ref 12, which is not reproduced here, gives a typical record of radiography. Fig 3, which is reproduced here as Fig 2, gives the path vs time diagram (x,t) for points along the axis in the case of 30 mm diam chge. The (x,t) curves were graphically derived to give the material (particle) velocity vs time (u,t), the time origin being the same for different foils. The variation of the material velocity with respect to the distance to the shock front was then established by using the x(t) and u(t) curves, at different initiation point-to-shock front distances; u was given for different foils, for given t and for given space coordinate

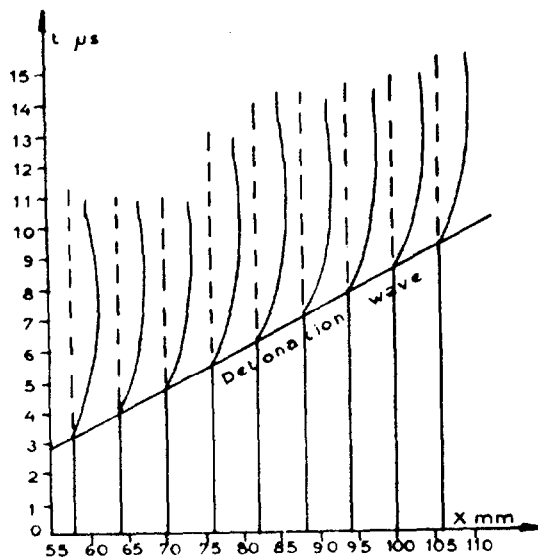

Fig 2 (x,t) diagram -- cylindrical charge 30-mm diameter

$Z=X_D-X$, where X_D is the position of the shock front at that instant and X the position at initial point. By varying t within the regions of densest beam of the curves $u(t)$ in order to obtain the maximum number of points $u(Z)$ was calcd. Figs 4, 5 & 6 of Ref 12 which are not reproduced here give various $u(Z)$ diagrams. Theory and calculations given on pp 42-5 are not described here, but we are giving Fauquignon's conclusions, as outlined in Abstract on p 39. The deton of a cylindrical chge may be considered as a steady phenomenon if the ratio length/diam is large enough. The radiographic observation of the motion of very thin gold foils, carried along by the burned gases, allowed verification of the above statement. The experiments permitted the measurement of the particle velocity of the gases along the axis and the measurement of zero-velocity points given as a function of their distance to the shock front

- Refs:1) J.C. Clark, JApplPhys **20**, 363 (1949)
 2) R.F. Duff & E. Houston, JChem Phys **23**, 1268 (1955) 3) J. Viard, CR **244**,1619 (1957) 4) P. Carrière, 'Publications Scientifiques et Techniques de Ministère de l'Air,' n°339 (1957) 5) W.E. Deal, JChem Phys **27**, 796 (1957)
 6) A.N. Dremin & P.F. Pokhil, DoklAkad N **128**, 889 (1959)
 7) C.E. Hauver, 3rd ONRSymp Deton (1960), p 120 8) C. Fauquignon, C.R. **251**, 38 (1960) 8a) J. Berger et al, Annales dePhysique **5** (13), 1144-77 (1960) & CA **55**, 10890 (1961)
 9) M.A. Cook et al, JAppl Phys **33**, 3413 (1962) 10) M.L. Wilkins et al, UCRL (Univ Calif Radiation Lab) Rept **7797** (1964) 11) B.G. Craig, 10th Symp. Combstn (1965), p 863-67
 12) C. Fauquignon et al, 4th ONRSymp Deton (1965), pp 39-46

Detonation Velocity, Dual. See Detonation High-, Low-, and Intermediate Order Velocities of

Detonation Velocity, Effect of Replacement of Air in Explosive Charges by Non-explosive Liquids. Accdg to Urbanski et al, (Refs 1 & 2), detonation velocities of expls, such as RDX or PETN are appreciably increased when the air contained in them is replaced by a non-expl liquid such as glycerin, acetone, etc

Cook (Ref 3) discusses the effect of water on an AN/Al mixt contg ca 12 % water which results in a mixt capable of large-diam blasting strength (underwater) of unprecedented magnitude. The high expl potential of such a mixt is illustrated by heat of expln of 50/30/20 AN/Al/ Water which gives a value of 1600 cal/g vs that of 40/40/20 AN/Al Water which is 2100 cal/g, the probable practical limit of such mixts

Refs: 1) T. Urbanski, Compt Rend 18^e Congr Chim Ind, Nancy, France, Sept-Oct 1938, 429-32 & CA 33, 6047 (1939) 2) T. Urbanski & T. Galas, CR 209, 558-60 (1939); CA 34, 265 (1940) 3) Cook (1958), 304 & 320

Detonation Velocity vs Explosion (or Ignition) Temperature

See Table 8 under DETONATION (EXPLOSION AND DEFLAGRATION) VELOCITY

Detonation Velocity, External Pressure Influence on. See Detonation Velocity-Pressure Over Explosive Relationship

Detonation and Explosion Velocity in Gases. That gases can burn (like in Bunsen burner) has been known for a long time, but their property to detonate under certain conditions was discovered only in the last quarter of the

19th century by French scientists M. Berthelot & P. Vieille and by E. Mallard & H. Le Chatelier. They started investigations with stoichiometric mixture of hydrogen and oxygen. In their experiments, gas contained in a 5mm rubber tubing, 40m long, was initiated at one end of the tube by means of an electric MF detonator. The tube could be open or closed. Two strips of tinfoil were included on the electrical circuit of a chronograph and the time between their breaks served to aid in the calcn of detonation velocity. This was found equal to ca 2810m/sec and there was no difference which material was used as the tube (rubber, lead, glass), provided its diameter was not below a certain value (2mm). For example, deton vel in a glass tube of 1.5mm diam was found to be for oxyhydrogen ca 2341 m/sec (Ref 5, p 144-45)

Dixon (Ref 1) repeated experiments of French scientists, but he used lead tubes 9mm in diam and 100m long. The results were 2821m/sec for oxyhydrogen, 2322 for methane & oxygen and 2321 for cyan gas & oxygen. Berthelot's values were 2310, 2287 and 2195 m/sec, respectively. Dixon extended the investigations and found that initial temperature and pressure influence the velocity only to a small degree, while inert additives or excess of one of the components beyond the stoichiometric compn diminished appreciably the velocity. In some cases the effect of addn of inert substances was to increase velocity, as for example of water vapor to mixts of CO with oxygen

Cook's discussion (Ref 2, pp 45-6) is translated into Russian in abbreviated form in the book of Andreev & Belyaev (Ref 5, pp 146-48). Studies of mixtures of H₂-O₂-N₂, H₂-O₂-A, C₂H₂-O₂ and others covering the range of initial pressure from below atmospheric to 50-100atm showed that velocity frequently followed

closely the (constant temperature) relation:

$$D^* = D^* \rho_1^{\circ} + \beta^* \log(\rho_1 / \rho_1^{\circ}) = D^* \rho_1^{\circ} + \beta^* \log(p_1 / p_1^{\circ}), \quad (3.2)$$

Where ρ_1° and p_1° are reference values for initial density and initial pressure, respectively usually set = 1.0; ρ_1 and p_1 are arbitrary initial density & pressure of gaseous mixt; $D^* \rho_1^{\circ}$ and $D p_1^{\circ}$ are ideal deton vel at ρ_1° and p_1° , respectively and β^* a factor corresponding to the increase in velocity for a tenfold increase in density or pressure

Cook's Table 3.2 is reproduced here as Table 1. Besides giving pressures in psia as in Cook's, we are including values in kg/cm^2 , taken from Ref 6

Table 1

| Gaseous Mixture | P_1° (kg/cm ²) | P_1° (psia) | $D^* \rho_1^{\circ}$ (m/sec) | β^* (m/sec) |
|---|-------------------------------------|----------------------|------------------------------|-------------------|
| 4H ₂ +1O ₂ | 0.7 | 10 | 3220 | 325 |
| 3H ₂ +1O ₂ | 0.7 | 10 | 3100 | 250 |
| 2H ₂ +1O ₂ | 0.7 | 10 | 2850 | 160 |
| 1H ₂ +1O ₂ | 0.7 | 10 | 2300 | 100 |
| 1H ₂ +2O ₂ | 0.7 | 10 | 1920 | 10 |
| 1H ₂ +3O ₂ | 0.7 | 10 | 1890 | -240 |
| 2H ₂ +1O ₂ +½A | 0.7 | 10 | 2460 | 130 |
| 2H ₂ +1O ₂ +1N ₂ | 0.7 | 10 | 2420 | 60 |
| 2H ₂ +1O ₂ +2N ₂ | 0.7 | 10 | 2220 | 50 |
| 3C ₂ H ₂ +1O ₂ | 1.05 | 15 | 2520 | 0 |
| 2C ₂ H ₂ +1O ₂ | 1.05 | 15 | 2660 | 45 |
| 1C ₂ H ₂ +1O ₂ | 1.05 | 15 | 2920 | 160 |
| 2C ₂ H ₂ +3O ₂ | 1.05 | 15 | 2720 | 150 |
| 2C ₂ H ₂ +9O ₂ | 1.05 | 15 | 2200 | 120 |

Results of Cook's Table 3.2 are plotted in the form of detonation velocity D, versus log p, in Fig 3.1 (which is not reproduced here) but shown in Ref 5 as Fig 4.15 on p 147)

Deton vel depends strongly on the proportion of a combustible and an oxidizer in a gaseous mixture - the closer the proportion to stoichiometric mixture, the higher is the velocity. Fig 4.14 on p 145 of Ref 5, gives velocity vs composition for propane-oxygen mixtures. As can be seen from this Fig 1, detonation stops if percentage of C₃H₈ drops below 3.1 or exceeds 37

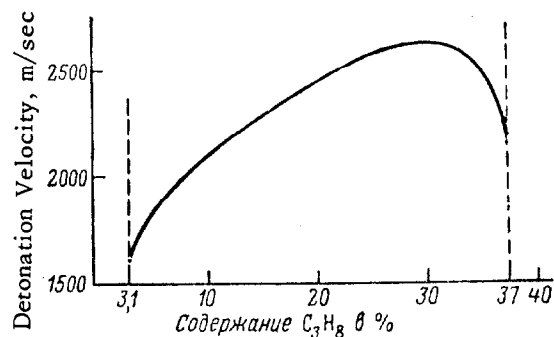
Fig 1 %C₃H₈ in Mixture with Oxygen

Addn of inert gases diminishes, as a rule, deton vel, except in cases when at wt of inert gas is so low that its presence diminishes the mol wt of original mixture. For example, gases having similar sp heats, such as Ar, N₂, He, and H₂, influence the deton vel in a different manner, when added not in great excess. Ar (at wt 39) and N₂ (mol wt 28), being the heaviest, diminish the deton vel, while He (at wt 4) and H₂ (mol wt 2), being the lightest increases it. Table 2 shows results of addn of Ar, He or N₂ to mixts of 2H₂+O₂. As can be seen from this table, the presence of inert gas, He increases considerably the deton vel of 2H₂+O₂ mixt if it is added in quantities up to 5He. Higher quantities, however, will have an adverse effect which is not shown in Fig. A similar table is given in Ref 3, p 241

Table 2

| Composition of Mixture | Detonation Velocity, m/sec |
|--|----------------------------|
| 2H ₂ + O ₂ | 2819 |
| 2H ₂ + O ₂ + 1.5Ar | 1950 |
| 2H ₂ + O ₂ + 3Ar | 1800 |
| 2H ₂ + O ₂ + 5Ar | 1700 |
| 2H ₂ + O ₂ + N ₂ | 2407 |
| 2H ₂ + O ₂ + 3N ₂ | 2055 |
| 2H ₂ + O ₂ + 5N ₂ | 1822 |
| 2H ₂ + O ₂ + 1.5He | 3010 |
| 2H ₂ + O ₂ + 3He | 3130 |
| 2H ₂ + O ₂ + 5He | 3160 |

Introduction of small amts of water vapor into dry mixts of 2CO+O₂ increases their deton vels, provided the percentage by vol of H₂O in mixt is not higher than 38.4. Table 3, taken from p 146 of Ref 5, gives some values. The addition of some hydrogen contg gases, such as hydrogen sulfide, ammonia and ethylene, has the same effect as H₂O vapor

Table 3

| % Compn of Mixt by Volume | Detonation Vel, m/sec |
|---|-----------------------|
| 2CO+O ₂ , dried over P ₂ O ₅ | 1264 |
| Diritto with 1.2%H ₂ O | 1676 |
| " " 2.3 " | 1703 |
| " " 3.7 " | 1713 |
| " " 5.6 " | 1738 |
| " " 9.5 " | 1693 |
| " " 15.6 " | 1666 |
| " " 24.9 " | 1526 |
| " " 38.4 " | 1266 |

Increase of initial pressure of mixtures increases slightly their deton velocities. This is probably due to the diminution of dissociation of products of expln since the overall pressure is increased

Increase of initial temp at constant initial pressure diminishes slightly the deton velocity as can be seen from Table 4, reproduced from Ref 5, p 148

Table 4

| Initial Temp °C | Compn of Mixture | Detonation Velocity, m/sec |
|-----------------|--|----------------------------|
| 10 | 2H ₂ + O ₂ | 2821 |
| 100 | 2H ₂ + O ₂ | 2790 |
| 10 | C ₂ H ₂ +3O ₂ | 2581 |
| 100 | C ₂ H ₂ +3O ₂ | 2538 |

Baum et al (Ref 3), besides giving on p 241 Table 52 which deals with influence of inert gases Ar & N₂ on deton vel of 2H₂+O₂ mixts, discuss on p 242 the results of Dixon's work on increase of deton vel of 2H₂+O₂ from 282/m/sec to 2872 when the initial pressure was increased from 760 mm to 1500mm Hg. They also state that a much greater increase in vel can be achieved if pressures are increased much higher. For example, LeChatelier determined that increase of pressure of acetylene-oxygen mixtures from 5 to 30 atm, increased deton vel from 1000 to 1600 m/sec

Influence of density on deton vel of gases, discussed on p 244, includes a statement that deton vel of 2H₂ + O₂ mixts increase from 3000 to 4400 m/sec, when density is increased from 0.1 & 0.5 g/cc. Fig 68, reproduced here as Fig 2 shows the curve of deton vel vs density for 2H₂+O₂ mixtures

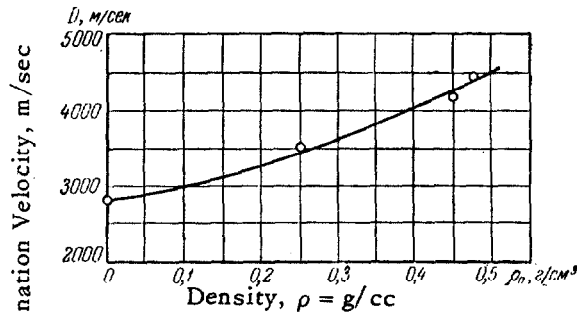

Fig 2. Density vs Detonation Velocity of 2H₂+O₂

Zel'dovich & Kompaneets (Ref 4, p72-83) give calculation of detonation velocity for stationary motion of gas. The expression for diatomic gas is:

$$D = \sqrt{2(k^2 - 1)Q}$$

where k = 9/7 and Q is the chemical energy

Refs: 1) H.B. Dixon, *TrRoySoc (London)* **1893**, p 97 and *Ber* **26**, *Band IV* (1893)
 2) Cook (1958), 45 - 8
 3) Baum, Stanyukovich & Shekhter (1959), 240-43
 4) Zel'dovich & Kompaneets (1960), 72-83
 5) Andreev & Belyaev (1960) 144-148

Detonation Velocity vs Heat of Combustion and Heat of Detonation (or Explosion). See Table 8, under DETONATION (EXPLOSION AND DEFLAGRATION) VELOCITY

Detonation Velocity vs Heat of Formation. See Table 8, under DETONATION (EXPLOSION AND DEFLAGRATION) VELOCITY and also under Detonation Velocity and Chemical Composition and Detonation Velocity as a Function of Oxygen Balance and Heat of Formation

Detonation Velocity, High-Low-, and Intermediate Order. See Detonation; High-, Low-, and Intermediate Order Velocities of

Detonation Velocity-Homogeneity of Charge Relationship. See under Detonation Velocity Particle Size Distribution Relationship

Detonation Velocity, Influence of Ageing of Gelatin Explosives on. Ageing of dynamites and its influence on their sensitivity to detonation by influence was described in Vol 1 of *Encycl*, pp A110 to A112, but its influence on deton velocity was not discussed. Ageing of propellants was described on p A112

In the book of Cook (1958), pp 50-51 it is stated under "Transient and Unstable Detonation Waves", that one of the first types of unstable or metastable detonation phenomena observed was the low-velocity detonation of liquid NG, Blasting Gelatin and Gelatin Dynamites. In these expls, low velocity is obtd in small diameter chges by use of cap initiation, and sometimes occurs even under heavy boosting and in large diameters, especially in *aged gelatins*. Photographic studies have shown that it is associated with very incomplete reaction of the explosive.

For example, following passage of the low-velocity deton wave, there is sometimes observed a 2nd and even a 3rd deton wave initiated by high-temp reaction following expansion of the unreacted mass of expl by the gases produced by partial reaction in the initial low-velocity wave. The explanation of this phenomenon lies in the fact that the covolume of the products of deton may be even greater than the volume of free space available to these products when the pressure is low. This causes reactions initiated by relatively low-intensity shocks to be quenched as soon as the available free volume in the expl is filled. Since the covolume decreases with increasing pressure strong shocks initiate high-order deton, and weak shocks, low-vel deton. This phenomenon, termed *space catalysis*, allows one to predict that the low vel will decrease with increasing density since the free space will be reduced as density is increased. On the other hand the normal high-vel deton increases with density. These effects have been observed in systematic studies of gelatin expls. However, they are complicated by the air-bubble-size effect. In a fresh gelatin expl, microscopic size, air bubbles are uniformly distributed thruout the mass, but upon aging the air bubbles coalesce, thus growing in size but decreasing in numbers. This results in a decrease in velocity of the low-velocity wave and an increase in velocity of high-velocity wave. Fig 3.9 in Cook's, p 51 (reproduced here) shows influence of aging on high and low velocity of a gelatin. These changes in velocities are taking place without a change in the average overall density. This can be explained by the fact that if the bubbles grow larger than the reaction-zone length, the wave propagates at the velocity corresponding to the microscopic density instead of macroscopic density of gelatin [See also Detonation; High-, Low-, and Intermediate Order Velocities of]

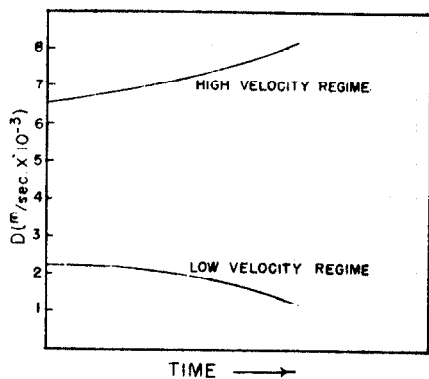

Figure 3.9 Influence of aging on high and low velocity of a gelatin

Detonation Velocity, Influence of Brisance on. See Brisance-Detonation Velocity Relationship, in Vol 2 of Encycl, pp B 297 to B 299, including Table 1.

Detonation Velocity, Influence of Charge Density on. See Detonation Velocity-Charge Density Relationship

Detonation Velocity, Influence of Charge Diameter on. See Detonation Velocity, Charge Diameter and Density Relationships

Detonation Velocity, Influence of Charge Temperature on. See Detonation Velocity-Temperature of Charge Relationship

Detonation Velocity, Influence of Confinement on. See Detonation Velocity - Confinement and Obturation Relationship

Detonation Velocity, Influence of Electrical and Magnetic Fields on. See Detonation Velocity, Influence of Magnetic, Electromagnetic and Electrical Fields as well as of Electrons on

Detonation Velocity, Influence of External Pressure on. See Detonation Velocity - Pressure Over Explosive Relationship

Detonation Velocity, Influence of Inert Components and Inert Additives. Cook (Ref 1, p 211), under the heading "Influence of Inert Additives on the Detonation Velocity of Ideal Explosives", gives a formula for determination of detonation velocity of an explosive contg an inert additive if velocity of pure expl is known. He also gives formulas for determination of temperature and pressure of detonation of such mixtures

On p 212 he states that a chemically inactive solid may be made to behave effectively as an inert not only chemically but also thermally by careful selection of its particle size. For example, while only a small percentage of powdered NaCl is capable of quenching detonation in the most sensitive explosives, coarse NaCl (eg - 10+30 mesh) can be added in amounts as much as 90 to 95% in the most sensitive expls, such as fine-grained RDX, without quenching detonation. This is because if the inert additive is very coarse deton will propagate betw grains at nearly the vel of the pure expl. This also shows that with the coarse granulation, heat loss due to vaporization of the NaCl is negligible, and the salt thus acts as a chemically and thermally inert additive (Ref 1, p 212)

Cook's discussion about use of NaCl as additive, reminds us that during WW11 Germans used it, in amounts as high as 50-60%, in mixtures with TNT. These expls were known as "Kochsalzsprengstoffe" and they belonged to the group of "substitute explosives" (*Ersatzsprengstoffe*) developed by Germans due to the shortage of conventional expls, such as organic nitro- and nitrate- compds, inorganic nitrates, chlorates, perchlorates etc. These expls are described in Ref 2, pp Ger 43 & 44. Previous to use of NaCl, the expl contg TNT 45 & Na nitrate 55% known as *Sodatol*, was used (Ref 2, p Ger 186). Instead of NaCl, KCl and the substance known as *Scheide mehl* (a powdered mixture of Ca & Mg silicates) (p Ger 43) was used. Instead of Na nitrate, K or Ca nitrates were used in some of the *Ersatzsprengstoffe* (See Table 15 on p Ger 44). An interesting inexpensive expl, known as *Bikarbit*

was developed by the Ger firm WASAG before WWII. This expl could be initiated by an ordinary blasting cap, although it contained as high as 95% of inert material (powdered NaHCO_3) and as little as 5% NG. Another expl, developed by WASAG, contd NG 15, NaHCO_3 50 & NaCl 35%. Its deton vel was 2500 m/sec (at density 1.35) and it could be initiated by a No 2 blasting cap. If a more powerful and brisant expl was desired, the amt of NG was increased to 15% and part of NaCl was replaced by fuel and Na nitrate (Ref 2, pp Ger 11 & Ger 12)

Baum, Stanyukovich & Shekhter (Ref 3) stated that incorporation of inert inorganic and organic compounds, decreases deton velocity, generally, but there are, however, exceptions. For example incorporation of 5% paraffin or wax in RDX of d 1.50 g/cc decreases its velocity from 7900 m/sec to 7640, whereas, incorporation of 3-5% of paraffin or wax in MF, increases its velocity, but not much. Addn of some inert components to TNT decreases its vel but not to a great extent, as can be seen from the following table:

Table

| Explosive | Density g/cc | Velocity m/sec |
|----------------------------|-----------------|-------------------|
| TNT | 1.61 | 6850 |
| 50/50-TNT/NaCl | 1.85 | 6010 |
| 75/25-TNT/ BaSO_4 | 2.02 | 6540 |
| 85/15-TNT/ BaSO_4 | 1.82 | 6690 |
| 74/26-TNT/Al | 1.80 | 6530 |

It should be noted that Al, which increases power of expls, lowers the deton velocity. Baum explains it by the fact that Al reacts with products of deton only in the rarefaction wave zone and this excludes the transfer of energy evolved by Al into deton wave so that vel could be increased

Andreev & Belyaev (Ref 3) also stated that inert additives generally decrease the velocity, but there are exceptions, as for example in cases of MF and NC. Increase of MF vel on phlegmatization with paraffin was mentioned by Baum

et al (See above). In case of NC, the incorporation of some water prior to compressing the chge increased the vel from 5300m/sec (for dry product) to 6100m/sec (for wet product). On the other hand incorporation of 25% kieselguhr into NG lowered its vel from 7430 m/sec to 6630 m/sec

Refs: 1) Cook (1958), 211-13
2) Fedoroff et al, PATR 2510 (1958), pp Ger 12-13, Ger 43-44 & Ger 186
3) Baum, Stanyukovich & Shekhter (1959) 296-97 4) Andreev & Belyaev (1960), 208

Detonation Velocity, Influence of Initial Temperature of Charge. See Detonation Velocity-Temperature of Charge Relationship

Detonation Velocity, Influence of Magnetic, Electro Magnetic and Electrical Fields as well as of Electrons on.

In order to determine the influence of magnetic fields on detonation velocity of expls, Marino (Ref 5) conducted determination of detonation velocities by means of "ionization probing" using as the explosive standard Primacord. As shown in experimental arrangement in Fig 1, two pins were inserted into the Primacord opposite each other and just thru the polyethylene cover. Another similar set was inserted exactly 5 inches from the 1st set. An eight megacycle Potter counter chronograph measured the time it took for the detonation wave to travel the distance between the two sets of ionization probes. The electronic circuitry, applying magnetic field of field strength 400 Π oersteds, is shown in Fig 2. The field applied was along the length of the Primacord and in the direction of detonation. It was shown by experiments that this field exerted no influence on the counter chronograph. An average of 16 tests without vs 11 tests with the application of magnetic field showed that there is no significant difference (probably no more than 5%) in detonation velocities with or without the field. Experiments repeated, using distances betw pins other than 5 inches

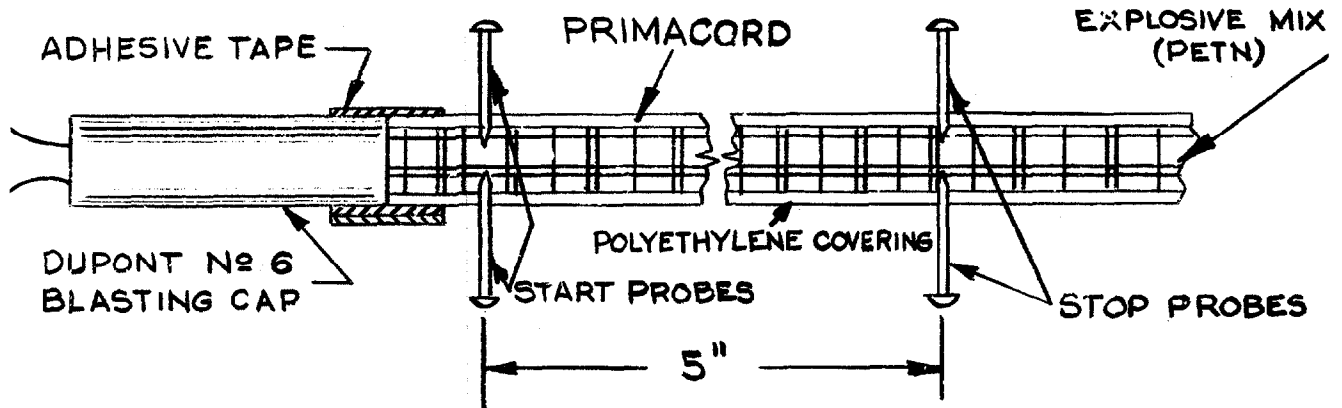

PROBING DIAGRAM

FIG 1

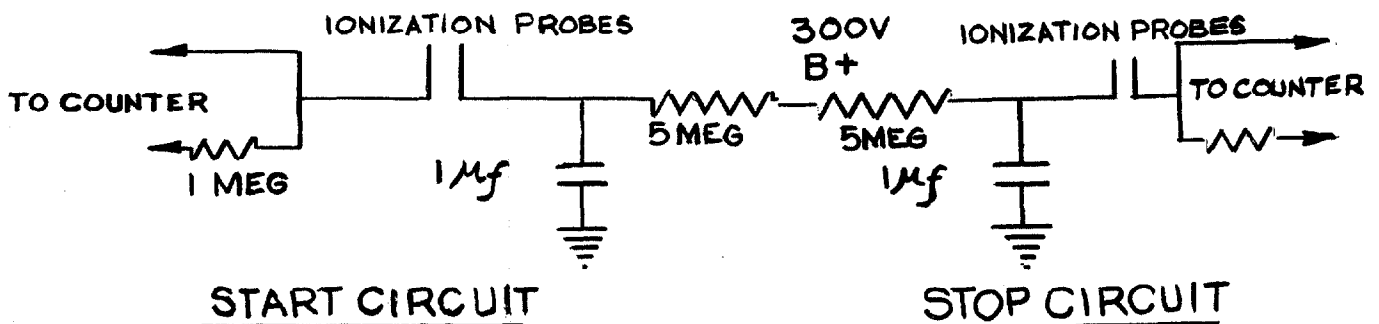

CIRCUIT DIAGRAM

FIG 2

(such as 4, 6 & 7, gave the same detonation velocities as with pins 5 inches apart)

It has been suggested that with more accurate experimental arrangement, it would be possible to detect some influence of magnetic field, as was detected with electromagnetic fields described by Cook

According to Cook (Ref 7), J.J. Thomson suggested the possibility of influencing the propagation of detonation waves by means of external magnetic and electrical fields. This suggestion was investigated in 1914 by H.B. Dixon et al in various gaseous explosion mixtures with negative

results. However, in 1924, Malinovskii et al (Ref 1) succeeded in observing the effect predicted by Thomson in benzene-air mixtures and later (Ref 2) in methane-ethylene, and acetylene-air mixtures. In some cases they were able to quench detonation completely by an applied magnetic field, and in one experiment they determined the temperature coefficient of voltage required to quench detonation in 20 mol % acetylene and 80% air to be positive. Malinovskii & Lavrov stated that negative charges actively propagate the detonation wave in 25/75 mol % acetylene-

air mixt. Bone et al (Ref 4) confirmed Malinovskii's results in the spinning detonation of a moist $2\text{CO} + \text{O}_2$ mixts. They showed that when the deton wave in this mixt traversed a longitudinal (or axial) magnetic field the velocity was reduced by an average of 40 m/sec in an 8-cm long, 17-mm diam coil carrying current sufficient to produce a 35000-gauss field; and an average of 60 m/sec in a 58-cm long, 19-mm diam coil at a 22000-gauss field. A transverse field, however, had no influence on the propagation of detonation wave. In this regard, it is necessary to remark that in spinning deton the path of the particle motion is around the tube with a small forward pitch rather than axial. Hence, the important component of the electron motion would be perpendicular to the field if the field were axial rather than transverse. Bone et al showed also that in passing from positive to negative in an electrical field of 500 to 5750 volts/cm, the pitch of the spinning detonation was slightly increased, and the velocity D , increased an average of 50 m/sec but never exceeded 100 m/sec. They also succeeded, when passing thru the field from negative to positive, in completely interrupting the spin and causing the wave vel to drop abruptly from 1740 m/sec to sometimes below 900 m/sec with the wave usually (but not always) picking up again beyond the positive terminal of the electrical field

Note: The observation of an increase in D by as much as 100 m/sec does not imply an increase in particle velocity, W , by a proportional amount; the observed slight increase in pitch of the spinning deton could cause a large increase in D with a smaller increase in W

Bone et al found also that upon drying of the $2\text{CO} + \text{O}_2$ mixt or upon addn of ca 0.3% hydrogen, the deton wave was stabilized against interruption or retardation by transverse electrical fields up to 5000 volts/cm

Bone et al attributed their positive results to the critical or detonation threshold nature of moist $2\text{CO} + \text{O}_2$ mixts. Presumably the expected interactions of

external fields always exist, but when the detonating gas system is not a threshold one, the influence of the applied fields is too small to influence D measurably. Apparently, therefore, Malinovskii's observations of positive effects in their methane, ethylene-, and acetylene-air mixts are also to be attributed to observations at the threshold of deton (Ref 7, pp 143-44)

An important result bearing on the influence of applied fields on gaseous systems detonating at their threshold conditions is the observation that a flame in a uniform electrical field is always bent toward the negative electrode, as was first observed by Lewis (Ref 3). An applied field would therefore tend to accelerate W in the direction of the negative electrode and away from the positive one. At detonation - threshold condition it is probably the W which becomes critical; ie a slight change in W at the deton-threshold would have a marked influence on propagation. One may easily understand the tendency of the threshold deton flames to be accelerated in traversing the field from positive to negative and to be quenched in traversing the field from negative to positive if the negative particle in the flame are electrons and the positives are ions

Although the existence of charged particles in the deton waves of solid expls has been known for some time, it was Lewis and then Bone et al who indirectly demonstrated the existence of electrons as well as positive ions in condensed and gaseous deton flames. However, it was not until 1956 that measurements of electron densities in the detonation waves of solids were carried out by Cook et al (Ref 6). They found free-electron densities in excess of $10^{17}/\text{cc}$ in the deton reaction zone dropping sharply outside the reaction zone (Ref 7, p144)

The work conducted by Cook et al and reported in Ref 6 is also described in Ref 7, pp 144-50, under the title "Measurements of Electron Densities in the Detonation Reaction Zone of Solid Explosives"

Andreev & Belyaev (Ref 8) describe action on various explosives of ions, electrons, U^{235} fragments, alpha particles, X-rays and of supersonic waves, but it is not stated how this action affects the deton velocity

[See also Detonation (Explosion and Deflagration) Velocity]

Refs: 1) A.E. Malinovskii et al, Zh KhimFiz 21, 469 (1924)

2) F. A. Lavrov & A. E. Malinovskii, ZPhysik 59, 690 (1930) & ZhFizKhim 4, 104 (1933)

3) B. Lewis, JACS 54, 1304 (1931) 4) W.A. Bone et al, TrRoy Soc 235A, 29 (1935)

5) L.F. Marino, "Influence of Magnetic Fields on Detonation Rates", PicArnsPhysResSecn, Research Memorandum No 5, Jan 1955, Dover, N. J.

6) M.A. Cook et al, "Measurement of Ionization and Electron Densities in the Detonation Waves of Solid Explosives", Tech Rept No 1, Contract AF-18 (603)-100, ERG, Univ of Utah, Sept 1956 7) Cook (1958), 143-44 8) Andreev & Belyaev (1960), 293-96

Detonation Velocity, Influence of Method of Initiation, called Influence of Starting Impulse by Andreev & Belyaev. Dunkle (Ref 1, p 205) stated that detonation velocity which a solid explosive may reach under given conditions, is dependent on many factors. One of these factors being the *nature of initiation*.

It is described fairly comprehensively in the book of Andreev & Belyaev (Ref 3, pp 206-08), under the title: "Vliyanie sil'nykh nachal'nogo impul'sa na skorost' detonatsii", which means "Influence of starting force of impulse on the detonation velocity". It is stated there, that Dautriche reported that when a charge of PA of density ca 1.73 g/cc in a paper cartridge, 20 mm diam, was initiated by means of 0.5g MF and 15g of dynamite (serving as a booster), deton velocity was 7280m/sec. If, however, the wt of dynamite booster was increased to 80g, the deton vel of PA in the region adjoining the dynamite increased to 7650m/sec and then further dropped to normal, which was

ca 7280 m/sec. This phenomenon, known now as *overdetonation* or *overdriven detonation* is always observed when a weak explosive is initiated by a very strong booster. This is also known as *overboosting*. In all the cases of solid expls which can be initiated only to high-order regime, the overdriven initial detonation velocity, gradually drops to normal if the charge of expl is sufficiently long. A different phenomenon is observed with some liquid expls, such as with NG or NG-contg expls, Dynamites. Such expls possess two velocities low and high. If initiator for NG chge is weak (such as a cap contg 0.4 to 2g MF), only low velocity such as of 900 to 2500 m/sec can be produced, but with a No 8 cap contg LA-Tetryl, the same NG could be initiated to detonate at velocity as high as ca 8000 m/sec, and this velocity did not diminish throughout the change. Some NG contg expls, such as Blasting Gelatin, initiated by weak cap to produce a low velocity, can change suddenly, with a jump, to a high velocity. This was observed when the diameter of charge was large and the chge was long. A similar phenomenon was observed with Dynamites contg small amounts of small particles of heavy materials, such as $BaSO_4$, $BaCO_3$, SiC, etc

Some solid expls, not contg NG, may also be initiated to low and high velocities. For example, flaked TNT (passing thru sieve with 8 openings/cm and retained on sieve with 12 openings/cm), of $\rho = 1.0g/cc$ in a cartridge of 21mm diam, detonated at a vel of 1120m/sec, when initiated with No 6 - LA - Tetryl without booster. The vel increased, however, to 3660 m/sec, when 12.5g Tetryl booster was inserted. Apin & Bobolev observed that for PETN (Rus TEN) initiated to deton at 4100 m/sec, the vel suddenly dropped to 2500 m/sec (Ref 4), p 208. See also Detonation (and Explosion), Initiation (Birth) and Propagation etc, Section 7

Refs: 1) Dunkle's Syllabus (1957-1958), 151-62, 205

- 2) Cook (1958), 154 (Thermal initiation)
 3) Baum, Stanyukovich & Shekhter (1959),
 not found 4) Andreev & Belyaev (1960)k
 206-08

Detonation Velocity, Influence of Oxygen Balance of Explosives on. See under Detonation Velocity and Chemical Composition and Detonation Velocity as a function of Oxygen Balance and Heat of Formation. See also Table 8, under DETONATION (EXPLOSION AND DEFLAGRATION) VELOCITY

Detonation Velocity, Influence of Particle Size Distribution of Explosive on. See Detonation Velocity-Particle Size Distribution Relationship

Detonation Velocity, Influence of Pressure Over Explosive on. See Detonation Velocity - Pressure over Explosive Relationship

Detonation Velocity, Influence of Starting Impulse on. See Detonation Velocity, Influence of Method of Initiation

Detonation Velocity, Influence of Temperature (Initial) of Charge on. See Detonation Velocity-Temperature (Initial) of Charge Relationship

Detonation Velocity; Low-, High-, and Intermediate Order. See Detonation; High-, Low-, and Intermediate Order Velocities of

Detonation Velocity by Metallic Transition of Sulfur. Joigneau & Thouvenin (Ref 1) reported a large increase in the elec conductivity of cryst sulfur when it was subjected to high transient pressure, but detected no sudden or discontinous transition to metallic condition. It was inferred from their results that a modified system should permit the use of sulfur as an active element of a pressure transducer for measurements in the kilobar range

Hauver (Ref 2) prepd a modified system using a thin disc of sulfur, 0.0050 inch thick and 9/32 inch in diam, insulated in Teflon. A number of tests were performed

in which the sulfur transducer was placed against the end of a 67/33 Baratol cylinder, 2 inches in diam x 3 inches long with a 2 x 3 inch Pentolite booster. The pressure-time curve obtd indicated the von Neumann spike followed by the Taylor wave. The spike width was judged to be 0.2 microsecond, indicating a reaction zone width of one millimeter

Hauver concluded that pressure-time measurements with a sulfur transducer in contact with detonating Baratol gave clear evidence of an initial pressure spike, and lends addnl confirmation to the hydrodynamic theory of deton proposed by von Neumann and others. The sulfur transducer appeared capable of good resolution over that portion of the pressure-time curve corresponding to the reaction zone, and may offer a method for investigating the reaction process

Refs: 1) S. Joigneau & J. Thouvenin, "Electrical Conductivity of Sulfur Under the Action of a Shock Wave", CR 246, 3422-25 (1958) 2) G.E. Hauver, "Pressure Profiles in Detonating Solid Explosives", 3rd ONRSympDeton (1960), pp 241-52 3) C. Fauquignon et al, 4th ONR SympDeton (1965), p 39 (Listed as "method based on the metallic transition of sulfur", without giving its description)

Detonation Velocity-Particle Size Distribution Relationship.

It may be stated, in general, that velocities of expl mixts contg fine grained AN are higher than those with intermediate and coarse grains. And this to a certain extent applies to Al particles

The effect of particle size was investigated in France by Burlot (Ref 1) and in US by Martin et al (Ref 2), Malin et al (Ref 3), Cook (Refs 4 & 5) and others

Accdg to Cook (Ref 5, p 49), the particle size effects of Al are relatively unimportant for sizes smaller than 35 mesh (such as in Tritonal & HBX). They are more important in AN-AL mixts. Particle size effects of AN are also very pronounced in these as well as all other

AN expls in diams appreciably less than d^*m (minimum diam for ideal deton). If particles of AN in expl mixts are not coated they might grow in size in storage and cause a decrease in velocity of deton. The curve, Fig 3.5, p 49 shows that velocity of fine-grained AN permissible contg 7% is higher than those of intermediate and coarse-grained AN

Accdg to Baum et al (Ref 6, p 285), investigations of Bobolev have shown that with diminution of crystal size of expls, the "critical" and "limiting" chge diams become smaller and the gap between them becomes narrower. The following table presents influence of particle size distribution on deton vel of PA & TNT

Table

| Explosive | Crystal size, mm | Density, g/cc | Critical diam, mm | Limiting diam, mm |
|-----------|------------------|---------------|-------------------|-------------------|
| PA | 0.75-0.1 | 0.95 | 9.0 | 17.0 |
| " | Fine-cryst | 0.95 | 5.5 | 11.0 |
| TNT | 0.2-0.07 | 0.85 | 11.0 | 30.0 |
| " | 0.05-0.01 | 0.85 | 5.5 | 9.0 |

Baum et al also stated on p 286, that particle size distribution has no influence on value of *maximum* deton velocity of pure HE's at given density, but it either delays or speeds up the reaching of such velocity. Particle size also has no influence on *critical* deton vel of a pure HE at a given density

The above statements apply also to expl mixtures, but for them the influence of particle size distribution on deton velocity extends to much larger critical and limiting diams. For example, Belyaev found (as quoted from Ref 6, p 286), that in finely ground Dynamon (AN 88 & peat 12%), the influence of particle size on deton vel extends to diams as high as 80mm

Accdg to Andreev & Belyaev (Ref 7, p 202), influence of particle size is noticeable only at diam of chge lower than the "limiting". In this case expls contg fine particles develop usually higher deton vels than those

with coarser particles. For chges of larger than limiting diameter the particle size has practically no influence on deton vel. The curve, Fig 4.39, p 202 of Ref 7 shows that deton vels of fine particle size-TNT are higher than those of coarse particles if chge diams are small (such as 5 to 15 mm), but for larger diams (such as 15 mm and higher) there is practically no difference in velocities

Refs: 1) E. Burlot, ComptRend18^e Congr-InternlChimInd(Nancy, France), Sept-Oct 1938, 930-36 & 1146-59; CA 33, 6049 (1939) (Study of the effects of crystal dimensions, nature of the gas present and diam of the cartridge on the deton vel of crystd expls, such as PETN) 2) F.J. Martin et al, "The Effect of Particle Size on the Detonation Velocity of Ammonium Picrate", OSRD 1755 (1943) 3) M.E. Malin et al, JApplPhys 28, 63-9 (1957) (Particle size effect in expls at finite and infinite diams) 4) M.A. Cook et al, JPhysChem 61, 189(1957) (Particle size effect in aluminized expls) 5) Cook (1958), 49, 102 & 128-30 6) Baum, Stanyukovich & Shekhter (1959), 285-86 7) Andreev & Belyaev (1960), 202-03

Detonation Velocity-Pressure Over Explosive Relationship. In Dunkle's Syllabus (Ref 4), the effects of temp & pressure on the initiation of expln and on its progress are discussed. For example, when hydrocarbon mixts are subjected to high temps & pressures, non-flammable gas mixts become expl, mild reactions become violent, and stable gas mixts become spontaneously reactive

High temp & pressure may facilitate initiation of detonation in a material which ordinarily decomposes quietly. The influence of pressure on the decompn rate of various expls was reported by Ryabinin (Ref 3). His data showed that high pressure increases the rate of decomp of Lead Styphnate thruout; it accelerates the initial stage but decelerates the final stage in the case of

Mercury Fulminate. Ryabinin suggests that these cases, which appear to be exceptions, may be due to greater ease of developing high temp in expl on initiation at high pressure, and to higher thermal conductivity

Muraour & Basset (Ref 1) made the observation that expls such as NH_3HI_3 , LA, Silver & Gold Fulminates, and AuNHCl , under pressures of 5000 kg/cm², can be initiated by an igniting wire to complete decompn. Secondary expls were found to undergo combustion w/o mechanical effect even at 10,000 kg/cm²

Accd to Ryabinin (Ref 2, it has been reported that high pressures favor (for some expls) the rate of deton. This might be due to the fact that at high pressure it is easier to develop high temp in the expl on initiation and also because the thermal conductivity is greater. A contrary effect was observed with some expls contg air bubbles

Accd to Andreev & Belyaev (Ref 7), an increase of air (or gas) pressure over liquid-or gelatinous expls contg gas bubbles or powdery expls with adsorbed air bubbles decreases detonation velocity, as well as lowers the sensitivity of the expl

For example, when a layer of powdered PETN was detonated at 30 atm pressure its vel was considerably lower than at atm pressure, but if the pressure were increased to 50 atm the deton stopped shortly after initiation. At pressures above 50 atm the chges could not be initiated. Similar influence of pressure was observed for Tetryl, TNT and NGu

If one admits that heat evolved on adiabatic compression of gas bubbles inside expls serves to increase their detonability, it is advantageous not to have them partly compressed at initial stage by high atm pressure. This is because such decrease in volume of gases will not evolve much heat on their adiabatic compression

Refs: 1) D.H. Muraour & M. Basset, "Study of the Influence of High Pressures on the Propagation of React-

ions in Explosives, Particularly the Initiating Explosives", *Chim et Ind* **45**, Suppl to No 3, 218-24 (1941)
 2) Yu.N. Ryabinin, *ZhFizKhim* **20**, 11 (1946) 3) Yu. N. Ryabinin, "The Influence of Pressure on the Thermal Decomposition of Explosives", *DoklAkadNauk* **58**, 245-48 (1947)
 4) Dunkle's Syllabus (1957-58), 143-44 5) Cook (1958)-not found listed in alphabetical index
 6) Baum, Stanuykovich & Shekhter (1959)-not found 7) Andreev & Belyaev (1960), 209-10

Detonation Velocity, Super-or Hyper-.
 See Detonation, Supercelerity (or Hypervelocity)

Detonation Velocity-Temperature (Initial) of Charge Relationship. Accd to Calvet (Ref 1), tests conducted at Univ of Marseille with some HE's, have shown that deton vels detd by Dautriche method, increased with an increase in initial temps. Following table presents the results:

Table

| Explosive | Deton Velocity, m/sec at | | |
|-----------|--------------------------|----------|----------|
| | 15° C | 173° | 183° |
| TNT | 7000 | 7450 | No deton |
| PA | 7080 | 7270 | 7850 |
| TNN | 5135 | No deton | 8500 |
| DNN | No deton | 5140 | 5240 |

Note: PA primers were used in each test. A specially constructed device was used for measuring vels of molten samples, such as at temps of 173 & 183° all the above expls, except PA. Extremely high vel for TNN at 183° was due to decompn of chge prior to initiation

McGarry & Stevens (Ref 2) detd by drum camera method the rates of deton of Tetryl, RDX & Comp A-3 (all in pelleted form); 50/50 Pentolite, TNT & Comp B (all cast); and hand-tamped Comp C-4. The rates of these sticks 1-1/8 inch in diam by 18 inches long were measured after exposure to initial low, ambient and high temps. It was found that the deton rates of these expls,

except TNT, at -70°F , RT & 140°F were not significantly affected by temp. TNT showed an av rate of 6820 m/sec after 16 hrs at 70°F as compared to 6510 m/sec after 72 hrs at 140°F

Andreev & Belyaev (Ref 5) conducted similar studies in Russia by detonating powdery expls in thin-walled lead tubes 12.5mm in diam at temps of $+25^{\circ}$, -80° & -183°C . Their results are given in the following Table:

Table

| Explosive | Density, g/cc | Velocity, m/sec at | | |
|------------------|---------------|---------------------|---------------|----------------|
| | | Deton $+25^{\circ}$ | -80° | -180° |
| MF | 1.69 | 3320 | 3060 | 3150 |
| | | 3200 | 2960 | 3170 |
| | | 3260 | 3270 | - |
| PA | 0.98 | Average 3260 | 3100 | 3160 |
| | | 4750 | 4390 | 4750 |
| | | 5000 | 4600 | 4840 |
| | | 5150 | 4130 | - |
| Ammonium Picrate | 0.86 | Average 4970 | 4370 | 4800 |
| | | 4110 | 4240 | 3920 |
| TNT | 0.90 | 4100 | 3960 | 4110 |
| | | 3850 | 3980 | - |
| | | Average 4020 | 4060 | 4020 |
| | | 4310 | 4800 | 4550 |
| TNT | 0.90 | 4460 | 4230 | 4570 |
| | | 4580 | 4250 | 4800 |
| | | Average 4450 | 4430 | 4640 |

This table shows that fluctuations in velocities are greater at lower temps, but averages are practically the same at low and at room temp. The fact that vel of Amm Pictate at low temp is higher than at RT is probably due to an increase in density on freezing (the densities shown in the table were detd at RT and they must be higher at -80° & -180°)

Tests with some cast expls have shown that velocities increased slightly with lowering of temp. This was shown to be due to increase in density. In case of liquids increases in velocities at low temps were more noticeable because their densities increased considerably with lowering of temp.

For example, vel of NMe was 6100 m/sec at $+60^{\circ}$ but it increased to 6400 at -20° . Tests of Belyaev and Kurban-galina showed that vels of other liquid expls, such as NG, also increased with lowering of temps

Refs: 1) E. Calvet, Ann Faculté de Science, Marseille, France **15**, 3-10 (1941) & CA **40**, 7632 (1946) (Deton vel-temp of chge relationship)

2) W.F. McGarry & T.W. Stevens, "Detonation Rates of the More Important Military Explosives at Several Different Temperatures", PATR **2383** (Nov 1956) 3) Dunkle's Syllabus (1957-58), pp 143-44
4) Cook (1958) - not found in Index
5) Andreev & Belyaev (1960), 208-09

Detonation Velocity vs Temperature of Detonation (or Explosion). See Table 8, under DETONATION (EXPLOSION AND DEFLAGRATION) VELOCITY, Section 11

Detonation Velocity Tests. See under DETONATION (EXPLOSION AND DEFLAGRATION) VELOCITY, Experimental Determination of Detonation Velocity and also under CHRONOGRAPHS in Vol 3 of Eneycl, pp C304-R to C319-L

Detonation Vibratory Phenomena and Instability of Self-Sustained Gaseous are discussed by N. Manson et al, in the 9th Symp Combstn (1963), pp 461-69

Detonation, Von Neumann's Spike Pressure and Spike Theory. See under Detonation, NDZ Theory of

Detonation, Vulnerable Radii of Demolition. See Vol. 2, p B182-R under Blast Effect Due to Reflected Shock Waves

Detonation, Water & Plexiglas Induced Shock Wave Velocity in. Cook et al (Ref 2) applied the "aquarium technique" in the exptl detn of the equation of state for water & Lucite. The results for water are compared with similar results by other methods. Measurements of the peak pressures in the deton wave are presented for RDX, RDX/salt, TNT & HBX-1. Peak pressures were found to be the CJ or deton pressures of the thermohydrodynamic theory. There was no evidence whatever for the "spike" of the Zel'dovich-von Neumann model even though conditions were such that this spike would have been detected by the method employed if it were present, at least in the large diam, nonideal expls of max reaction zone length
Refs: 1) C. Fauquignon, CR **251**, 38 (1960) 2) M.A. Cook et al, J Appl Phys **33**, 3413-21 (1962)
 3) C. Fauquignon et al, 4th ONRSymp Deton (1965), p 39 (Listed as "Water or plexiglas induced shock wave velocity", without giving its description)

Section 12

DETONATION (AND EXPLOSION) WAVES (Their Relation to Detonation Front, Detonation Zone, and Reaction Zone)

The shortest definition of the term *detonation wave* was given by Döring (Ref 8 & Ref 26, p 74). He regarded it as "a shock associated with chemical reaction". A longer definition, such as based on that given by Dunkle (Ref 51, p 2) is:

A *detonation wave* is a combination of two processes: a shock wave and a chemical reaction; each helps the other. The pressure shock initiates the chemical reaction and the latter, by evolving energy at the required rate, prevents the dying out of the shock. Such a chemical reaction has to meet two requirements: increase in volume of products over

that of the original explosive, and energy release. In addition, the system must provide confinement. Under these conditions the resulting pressure shock advances into the undetonated explosive, carrying the chemical reaction along with it. A true detonation, once conditions bring it about, continues at a constant rate as long as the conditions remain unchanged. For such period of time we can consider it a *steady-state process*. To an observer moving along with a detonation wave, it would not change with time but would appear fixed in space with fresh explosive being "fed" into it at a speed equal to the rate of detonation; the products of detonation (mostly gases, at high temperature and pressure) would be moving out, but at a lower rate

NOLR Handbook 1111 (Ref 30, p 7-15) defined the *detonation wave* as an intense shock or compressive wave of forward moving material that is supported by the very rapid exothermic decomposition of the explosive immediately behind the shock front. The pressure profile of a detonation wave occurring in a charge of finite extent has the appearance shown in Fig 1. At the shock front the pressure rises abruptly to a very high value of the order of 400000 atm. The resulting rapid compression of the solid expl raises its temp to ca 2000° and the expl decomposes rapidly with the evolution of energy. This decompn requires something less than 1 microsecond for completion, and in this time the shock front will have proceeded on a further distance "a". This is called the *reaction zone length* and the point at which the reaction is complete is known as the *Chapman-Jouguet (C-J) Point*. Distance into solid expl is the *Chapman-Jouguet (C-J) Plane*. Immediately behind the C-J plane the product gases, which have been compressed to a density even higher than that of the original solid expl, are moving forward (that is in the same direction as the detonation wave) with a velocity of some 1800 m/sec, about 1/4th as great as the velocity of the deton wave. At a still greater distance from the shock front, the product gases expand into the surrounding medium.

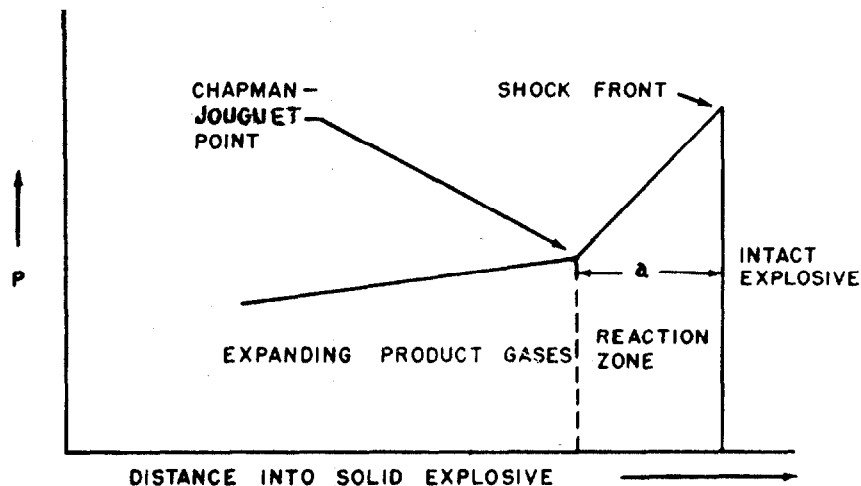

Figure 1 Pressure Profile of a Detonation Wave Occurring in a Charge of Finite Extent

At the C-J point, the pressure (p) and temp (T) are of the order of 200000 atm and 4000°C, respectively. For a *plane detonation wave* of infinite extent, p , T , "a" and D (deton velocity) have definite values for a given expl and depend principally on the physical and chemical properties of the unreacted expl and its deton products, as well as on the density of loading, ρ

The *reaction-zone length* "a" (See Fig 1) is the important parameter when considering boosting of main explosive charges. It largely determines how easily and how rapidly stable deton may be established in the main chge. The shorter the reaction zone length, the more rapidly and the more easily stable conditions are reached in the initiated expl.

Although the sizes of "a" for various expls are not exactly known, it is probably a correct assumption that the less sensitive an expl, the longer its "a". Thus primary expl have "a" probably of the order of 0.1mm or less, expls commonly used as boosters have it probably equal to 1-2mm, and insensitive HE's such as Amatols have it probably as high as 5mm

Evans & Ablow (Ref 66, p 147) stated that Zel'dovich, von Neumann & Doering defined the *detonation wave* as a reaction initiated by a shock. Evans & Ablow consider a deton wave as com-

posed of an initiating shock followed by a deflagration in which the pressure and density decrease from p_1, ρ_1 to p_2, ρ_2 .

They also stated that the earlier definition that a detonation wave is a shock followed by a reaction zone is not correct

The following discussion on *detonation front, detonation wave, shock wave, shock zone, detonation zone* and their interrelations is a combination of information taken from Ref 24, pp 952-55; Ref 24a, p 31; Ref 40, p 2 and Ref 51, p 167

It was probably D.L. Chapman, PhilMag [5], 47, 90 (1899) who first made the suggestion that a *detonation front* is a *shock wave*, self-sustaining by the energy released in the chemical reaction and therefore not involving "piston" (as described here under "shock tube") for *steady state propagation*. This means that the *material velocity*, u , in the detonation wave is not known a priori and so the three basic laws of conservation of *mass, momentum, and energy*, such as given under DETONATION (AND EXPLOSION) THEORIES (and repeated here for cohesion of this description) do not suffice to calculate the velocity of detonation

The *detonation zone*, proper, is considered to include: (1) a very narrow *shock zone* (also called *shock front*) and (2) a *chemical reaction zone* (See Fig 2). In the

The kinetic energy change is given by $\frac{1}{2} [(D-u)^2 - D^2]$. Hence, substituting the specific volumes, which are reciprocals of densities:

$$P_0 V_0 - pV = \frac{1}{2} [(D-u)^2 - D^2] + (e - e_0 - Q), \quad (3)$$

where the internal energy of the undetonated expl is divided into the term Q , representing the chemical energy to be evolved subsequently as heat and the remainder energy e_0 .

Note: In all above equations, as well as in eqs listed below, Dunkle uses symbol D for velocity, but Kistiakowsky uses U which accdg to definition given by him on p 950 of Ref 24 is the "velocity of propagation of plane shock front", while D designates stable velocity of detonation, accdg to Chapman (Ref 24, p 951)

Equations 1, 2 & 3 are known as the conservation equations

From equations 1 & 2 we can derive:

$$P - P_0 = \rho_0 D [D - (D-u)] = \rho_0 D u \quad (4)$$

$$\text{Also: } p - P_0 = \rho_0 D \left[\frac{D - \rho_0 D}{\rho} \right] = \frac{D}{v_0} \left[\frac{D - vD}{v_0} \right] = \frac{D^2 (v_0 - v)}{v_0} \quad (5)$$

$$\text{Hence: } D^2 = \frac{v_0^2 (p - P_0)}{(v_0 - v)} \quad (6)$$

Further from eqs 1 & 2:

$$(D-u)^2 = \frac{\rho_0^2 D^2}{\rho^2} = \frac{v^2 (p - P_0)}{(v_0 - v)} \quad (7)$$

Substituting the values of D^2 and $(D-u)^2$ from eqs 6 & 7 in eq 3 we obtain:

$$e - e_0 - Q = \frac{\frac{1}{2} (v_0^2 - v^2) (p - P_0)}{(v_0 - v)} + P_0 v_0 = \frac{\frac{1}{2} (v_0 - v) (p - P_0) + P_0 v_0 - p v}{(v_0 - v)} \quad (8)$$

and $e - e_0 = Q + \frac{1}{2} (p + P_0) (v_0 - v)$ Hugoniot Equation (9)

Eqs 6 & 7 along with 9 are sometimes called the Rankine-Hugoniot (R-H) Equations. The term Q is zero for the nonreaction R-H curve. These eqs are important in explosives theory. They permit correlation of the explosive characteristics of substances with other physical and chemical properties, and allow determination of the temperature and pressure conditions within the detonation zone

The R-H eqs express the $(v-p)$ relationship corresponding to any stage of reaction from start to finish inclusive. The energy e calcd by R-H eqs is the specific internal energy released not as heat but as work. This work is performed on the layer of explosive immediately ahead of the deton front, thus compressing it. The transmission of detonation itself depends on release of energy as work and not as heat (Refs 40 & 51) (See pp D726-27)

It must be noted that division of deton zone, illustrated in Fig 2, into two regions called the shock zone and the reaction zone is helpful in visualizing the deton process, but it is somewhat artificial. It is realistic for a dust explosion because here the shock does heat up the gas molecules and the gas is roughly in thermal equilibrium before any appreciable burning of the dust particles occurs. Similarly the division may be considered satisfactory for military HE's, partly because the reaction zone is very much wider than the shock zone and partly because conditions are in any case too complicated to permit more than a qualitative description. The division into two zones is not, however, entirely satisfactory for gaseous explosion, as was shown by experiments of various investigators cited by Penney (Ref 24a, p 5) (See p D725)

The above eqs 1, 2, 3 define any three of the four variables p , ρ , D & u in terms of the 4th, if it is assumed that eq of state of the medium, $f(p, \rho, T) = 0$ (where T is temperature), as well as the dependence of internal energy on any pair of these variables is known (Ref 24, p 950-51) (See p D725)

Chapman proposed that the deton velocity is the minimum velocity consistent with the Rankine-Hugoniot conditions. Equivalent with this is the postulate of Jouguet that the detonation velocity, is equal to the material velocity u , plus the acoustic velocity c , of the medium in the wave. This equivalence becomes evident on consideration of Fig 3, taken from Ref 24, where point a represents the initial state of the explosive, and the curve bc is the R-H curve of the products of its reaction, which will normally lie above point a if the reaction is exothermic. Inspection of reaction (7) given on p 951 of Kistiakowsky (Ref 24)

shows that if point e of Fig 3 represents the state of the products of detonation in the wave, the equation can be written as:

$$U = v_0 (\tan \alpha)^{1/2} \quad (10)$$

where U = vel of propagation of plane shock
 $v_0 = 1/\rho_0$ and α = the angle formed by the line ae joining the initial and the final state of the substance with the (negative) volume axis of the diagram. Thus, the tangent (at point d) to the R-H curve must represent the lowest possible detonation velocity and is the stable velocity D , accdg to Chapman.

Now if accdg to Jouguet: $D = c + u$, (11)
 then follows from eqs (7) & (8) given on p 951 of Kistiakowsky that:

$$c = v (p - p_0) / (v_0 - v)^{1/2}$$

but accdg to the theory of sound:

$$c = (\partial p / \partial v)_S^{1/2}$$

where $v = 1/\rho$ and S is entropy

If the Jouguet assumption is:

$$(p - p_0) / (v_0 - v) = -(\partial p / \partial v)_S$$

then the tangent, ad , to the R-H curve is also tangent to the adiabatic curve of the products passing thru point d of Fig 3

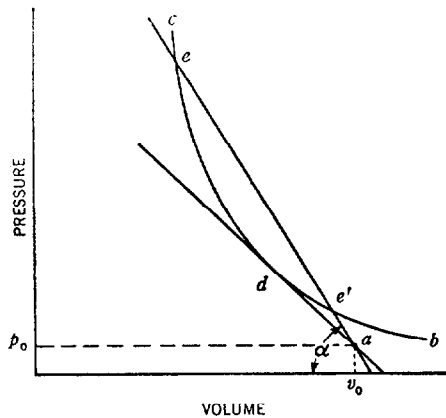

Fig 3 Chapman-Jouguet velocity of detonation waves

One is reminded by Kistiakowsky that the R-H curve represents states of changing entropy and, therefore, in general, intersects the adiabats, but it may be tangential to them at some points (Ref 24, p 953)

It is also stated by Kistiakowsky, that the theoretical justification of the minimal value for the stable detonation velocity

is not simple and is not discussed in detail in his work, but a clearer summary was presented by Cole (Ref 20a, Chapter 3, pp 67-109). In brief, the elimination of final states (such as e in Fig 3) above point d is justified on the ground that for these states the deton vel is less than $c + u$ (although greater than D), so that the rarefaction wave is able to overtake the deton front, and the pressure is reduced until the state described by point d is realized. The best argument against states below d (for instance, e) has been presented by von Neumann (Ref 6) whose reasoning can be made plausible with the aid of Fig 4. He started with the assumption that the chemical reactions in the detonation wave require a finite time for completion, or in other words that there exists a zone of finite thickness, within which the extent of the primary explosive reaction changes from 0 to 1. The stationary state of the wave requires that the "shape" of this zone does not vary with time, meaning that states of various extent of reaction all move with the same detonation velocity D .

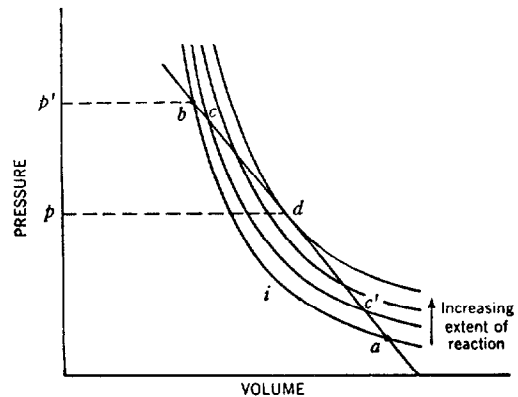

Fig 4 Derivation of the Chapman-Jouguet detonation velocity

Accdg to Kistiakowsky's eq (10) (listed above), therefore, they all lie on the same straight line, ab , drawn from the original (unreacted) state of the explosive. Suppose that the R-H curves relating to various extents of the reaction of the explosive are as represented in Fig 4. This is certainly true for gaseous expls and has been shown also by Brinkley & Wilson (Ref 7a) to be true for ordinary solid granular explosives. Let

aib represent the R-H curve of the expl, which has undergone chemical reaction, only to an infinitesimal extent. Of the two possible states, a and b, the first is ruled out because it is identical with that of the unreacted explosive ahead of the deton front. In this state, the explosive could not be reacting with the extremely high velocity involved in detonation process. The state must therefore be represented by point b. Upon a slight reaction of the matter in the wave the state would exist and propagate with a supersonic velocity D , which is impossible. The successive states of the reacting expl slide, therefore, along bca line until the reaction is completed and point d (the C-J point), is reached. This discussion of von Neumann is important because it presents a definite picture of the *structure* of deton wave. The intact expl is initially subjected to a mechanical shock with a pressure p' , which may be considerably in excess of pressure p , calcd for the C-J plane. The impact of the shock starts a chem reaction, which is completed at the C-J plane; only secondary shifts of equilibria caused by the subsequent expansion and cooling of the products take place thereafter. The initial mechanical shock does, of course, dissipate energy as all shocks do; it requires steady supply of work to be propagated with a stationary velocity. Von Neumann showed, however, that the stationary deton vel, D , in the layer of incomplete reaction is less than the sum of the local acoustic velocity, c , and local material vel, u , because, considered for this layer, the phenomenon taking place is a mechanical shock wave of velocity D . Thus the energy released by the chem reaction within this layer can be transmitted forward to the shock front as an acoustic signal traveling thru the (moving) medium with the acoustic vel, c . What happens chemically back of the C-J plane is immaterial for the propagation of the wave, because at this plane the deton vel equals the sum of material and acoustic velocities; thus no signals from behind, including possible rarefaction waves, can pass thru C-J plane. (Ref 24, pp 953-54)

A similar presentation of von Neumann theory is given by Penney in Ref 24a, pp 6-7, where his Fig 2 is similar to Fig 4 shown here

It is further stated by Kistiakowsky (Ref 24, pp 954-55) that a restatement of above reasoning from a slightly different point of view may be helpful for a correct perspective on the situation existing in a detonation wave. Such wave, from a chem standpoint, starts in the intact explosive; certain fast reactions take place in it which may eventually progress to a state of complete hydrodynamic equilibrium, controlled by the local pressure and temp in the wave. Whether or not equilibrium has been attained, the composition continues changing as pressure and temp of the wave undergo further changes. The propagation vel of the wave, from the hydrodynamic point of view, is less than the sum of the local acoustic and material vels in the first layer of the wave. This relation gradually changes, the conditions in the latter layer of the wave being such that the deton vel is greater than the sum of local material and acoustic vels; in between there exists a unique plane in which these vels are equal. The C-J hypothesis asserts that in this plane, the expl reaction has already reached the state of complete thermodynamic equilibrium and that the released (maximum possible) chem energy is quantitatively converted into: (1) thermal, (2) compressional, and (3) kinetic energy of forward motion of the reaction products; the apportionment is controlled by the conservation equations, 5, 6, 7, 8 & 9 listed on p 951 of Ref 24; and consequently, a uniquely defined deton wave results, which has the stationary velocity defined by:

$$D = v_0 \sqrt{-\partial p / \partial v}_s, \quad (14)$$

where the expression under the square root should be calcd by the thermodynamic state of the C-J plane

Investigation at the USBurMines (Ref 27) of *one dimensional detonation waves* involving finite reaction velocity gave the following results: 1) Unless the reaction proceeds with a physically unrealizable

high velocity, transport effects such as thermal conduction and diffusions are completely negligible except, of course, in a shock front where their effects are adequately described by the conservation laws. It follows that the reaction must be regarded as initiated at a shock front, in conformity with the picture of J. von Neumann (such as described briefly above and more fully in Ref 6 and in Ref 24a, p 6) 2) The front of the rarefaction wave, in a region of non-vanishing reaction velocity, moves with respect to the medium at a velocity equal to the local sound velocity computed under adiabatic - and frozen - reaction conditions 3) If a reaction occurs in the rarefaction wave, a positive pressure wave eventually develops downstream and subsequently overtakes the front of the rarefaction wave 4) In the region upstream from the rarefaction wave (before the front of the latter is overtaken by a pressure pulse, if this occurs), a steady-state region may exist involving a shock front. The distance between the shock front and the rarefaction front will be a function of the shock strength or, alternately of the detonation velocity. The separation distance will be infinite for the theoretically ideal normal Chapman-Jouguet wave. As the detonation velocity decreases, the separation distance decreases and passes thru a minimum value

The above considerations, although obtd from the one-dimensional case, may be correlated with the charge-diameter effect and limits of detonability in the three-dimensional explosions

Following items related to detonation waves, detonation zone, etc are either described in the previous sections on DETONATION or listed in Refs under DETONATION (AND EXPLOSION) WAVES

Annular Detonation Wave. See Annular Detonation Wave in Section 1

Anomalous Detonation Wave. See under Detonation Waves, Transients in Propagation of

Billiard Ball Mechanism of $V_f(t)$. See under Detonation Wave Shape and Density Properties

Characteristics of Detonation Waves. Same as Parameters of Detonation Waves

Chemical Reaction in a Detonation Wave. See Refs 9 & 83 and under Detonation, Reaction Rate in p D 504

Chemical Reaction Zone. See Ref 30, p 7-15 and our description at the beginning of DETONATION (AND EXPLOSION) WAVES

Cissoidal Detonation Wave. See Detonation Wave, Cissoidal

Confinement Effect on the Detonation Waves in Solid Explosives. See Ref 47, listed on p D726

Course of Reactions in the Detonation Waves of Explosive Mixtures. This problem was investigated in Russia by Apin, Voskoboynikov & Sosnova and their paper was translated into English by Backman. It is listed here as Ref 83, listed on p D729

Some info on the progress of the reaction under the conditions of a deton wave can be obtd by studying the dependence of the deton vel D on the diam of chge d of mixed HE's consisting of components of different reaction properties (Deton vels were detd by ionization and optical methods). As a consequence of the difference in times of reaction of the decompn of these components, the growth of the vel with increases in the diam of the chge will not proceed continuously but by the attainment of the fixed value for some quantities corresponding to the completion of intermediate states of reaction. Analogous dependence of D on d may take place also for mixtures of the oxidizer-fuel type expls, if the "subreaction" after the decomposition of the expl components demands for its completion a significant interval of time because of the difficulty of diffusion under the pressure of the deton of the condensed HE's. Following are results of some experiments

The increase in the deton vel of TNT-combustible metal (such as colloidal boron) mixtures at chge diams greater than 40mm showed that metals (in particular boron) can burn-up in the deton wave of condensed expls with the liberation of an additional amt of heat which leads to the growth of

deton vel. This fact is often neglected in considering deton of powerful metallized HE's

It is assumed that in such expls the reaction of the wave proceeds in the following way: at first the expl components are completely decomposed in the specific volume and then after the elapse of some interval of time there begins an effective reaction of the subreaction betw the products of their decompn. The agreement of the results of the calcn of the deton vel D_3 (corresponding to the completion of the first stage of the reaction) with the exptl values of *pseudoideal* deton vel D_2 for a series of expl mixtures serve well to verify such a scheme of the course of the reaction

In the investigation of liquid expl mixtures, there was observed a strong dependence of the velocity on the diam of the chge, although it practically completely disappeared for individual liquids and monocrystalline expls

The fundamental cause of the "pseudo-ideal" deton vels that are observed in the progress by stages of the reaction at the deton wave front of mixed HE's is due to the kinetics of the decompn of the expl components. A whole series of factors have an influence on the rate of liberation of energy in the wave

Ideal deton velocities correspond to a composition of the products of deton which depend only on the contents C - H - N - O and the temp & pressure of deton; all the parameters of the ideal deton wave of a mixed HE can be calcd exactly the same way as is done for individual HE's. It should only account for the peculiarity of the progress of the reaction in a deton wave of mixed HE's, associated with the fact that at the start the expl components are decompd in a specific volume and then a prereaction takes place in the deton products. In the case when the decomposition of the deton products in the first stage is energetically more favorable than after the subreaction, the first stage of the reaction is responsible for the ideal velocity. This applies to mixtures of the type such as Pentolite

Accdg to CA 60,7861 (1964), the following mixts were investigated: 90/10 - TeNMe/Graphite, 90/10 - NH_4ClO_4 , Paraffin, 58/42 - RDX/AN; 90/10 - TNT/B; 30/70 - RDX/TNT; 20/80 - RDX/TeNMe; 76/24 - $\text{CH}_3\text{CH}(\text{NO}_2)_2$ / TeNMe; 24/76 - NMe/TeMe; 12/88 - Kerosine/TeNMe, and RDX 30 & 70 of 2% soln of polymethylacrylate in TeNMe. The deton vel of a mixt does not increase uniformly with an increase in charge diam. For most of the mixts studied, it was less than the ideal velocity. The measured velocity, called the "pseudo-ideal velocity", results from an intermediate reaction state in the wave front of the detonation. The intermediate state is caused by the differences in the decompn rates of the components. The pseudoideal rate for most of the mixts is determined by the decompn rate of the oxidizer. For B and TNT mixts, the pseudo-rate is greater than the ideal rate, indicating that metals can burn in the deton wave of condensed expls with an evolution of additional energy

Dark Detonation Wave. See under Detonation (and Explosion), Luminosity etc and in Ref 51, p 202, listed on p D727

Decaying Detonation Wave. See under Detonation; Attenuation, Break, Cessation, etc and Ref 52, pp 57-9, listed on p D727

Delayed Detonation Wave and Its Shaping. See ref 49, listed on p D726

Density Properties of Detonation Wave. See Refs 51 & 52 and under "Detonation Wave Shape and Density Properties"

Detonation Wave Behavior in Permissible Explosives. See Ref 46, listed on p D726

Detonation Wave Cissoidal. Under this term is known a wave in the form of a curve having a cusp at the origin and point of inflection at infinity. Such waves were investigated in France by Touvenin & Argus. Following is an abstract of their papers (Ref 90)

A creation of a vertex point in a deton wave was obtd by mismatching the constituents of a plane wave expl lens, that is, by causing a delay, Δt_0 on the axis of the lens in relation to its edge. The deton wave

transmitted by such a lens to the main expl chge had the form of a cissoid, and for a suitable value of Δt_0 , the Mach phenomenon appeared. This phenomenon was observed for chges having diam of 100mm, beginning with $\Delta t_0 = 3\mu \text{ sec}$

Detonation Waves, Cylindrically Symmetric Flow Within the Steady Zone in. See under Detonation Waves: Steady-State, Three-Dimensional, Axially Symmetric with Finite Reaction Rate

Detonation Waves, Densities in. See under Detonation Wave Shape and Density Properties and in Refs 44 & 52

Detonation Wave, Elastic. An elastic wave is one which temporarily disturbs the medium thru which it traverses; ie, after passage of the wave, the medium returns to its original state. Properties of elastic waves and of plastic waves were determined by Minshall (Ref 39) using pin contactors and crystals. Nawa (Ref 85) carried out theoretical and exptl studies on the transition of the energy generated by expls and the wave shapes of the generated elastic waves. The amplitude of an elastic wave was theoretically detd and experimentally correlated with sp energy and/or brisance of expls (See also Ref 92a) (Compare with Detonation Wave, Plastic)

Detonation Wave in Electromagnetic Field. See Ref 96b, listed on p D729

Detonation Wave, End Effect in. See under Detonation Wave Shape and Density Properties and in Ref 52, pp 91 & 98 (See p D727)

Detonation Wave, Energy Exchange in. See Ref 80, listed on p D728

Detonation Waves; Experimental Procedures for Determination of their Properties. See Refs 3, 32, 35, 44, 57, 67, 68, 69, 75, 94, 95a & 96

Detonation Wave with Fluctuating Velocity. See Ref 66, listed on p D728

Detonation Wave Front. See under Detonation Wave Shape and Density Properties and also in Refs 38, 44a, 51, 52 and 96

Following is an abstract of Ref 96:

Reaction fronts occurring in detonations in solid explosives or explosive gas mixts. cause measurable absorption and reflection effects in microwaves which meet the reaction zone either perpendicular to the front or transverse to its direction of spreading, just as do much produced shock-wave fronts in dil gases, as a result of their temp-dependent conductivity. In this way it is possible to follow the velocities of such processes, in general with good accuracy and with a spatial resolution of the order of magnitude of half the wave length of the radiation used, without having to interfere with the exptl region which could have an effect on the process under certain circumstances. From the magnitude of the microwave absorption and its change with time, information can be obtained about the ionization mechanisms (including the electron shock frequencies) and also about the equilibrium with the kinetic gas temps either known or measured in some other way. Results of a few typical examples of these measurements are discussed and directions are given for possible application of the method for the investigation of shock-wave processes in nonconducting solids

Detonation Waves in Gaseous Explosions. See Refs 10, 33a, 45, 54, 56, 60, 81, 84, 96a, 100, 104, 106 & 107

Detonation Waves, General Description. See Refs 2, 8, 19, 22, 24a, 30, 36b, 41, 42, 43, 49, 51, 52, 60, 62, 72, 73, 77, 87, 89 & 98

Detonation Wave, Hypervelocity (Supervelocity). See Ref 61 and Under Detonation, Supervelocity or (Hypervelocity) in, p D578

Detonation Wave, Ideal and Nonideal. See Detonation, Ideal and Nonideal and Ref 52, pp 48-50, listed on p D727

Detonation Waves, Interaction in Condensed Explosives. See Refs 91 & 92, listed on p D729

Detonation Waves, Ionization in the. See Refs 44 & 53, listed on p D727

Detonation Wave, Jumping. See p D421 and in Ref 52, pp 57-9, listed on p D727

Detonation Wave, Laminar. Under this term is known a wave consisting of several thin layers located one over another. This is an ideal model of detonation in which the stream lines divide the entire region of flow into an orderly series of fluid laminae conforming to the boundary configuration (See also Refs 75 & 97a)

Detonation Wave, Langweiler Model. See under Detonation Wave Shape and Density Properties and in Ref 52, Chapter 5

Detonation Wave, Lateral Expansion and Lateral Rarefaction in. See p D421 and under Detonation Wave Shape and Density Properties and in Ref 52, p 91

Detonation Wave in Liquids. See Ref 100

Detonation Waves of Low Velocity. See Refs 99 & 100, listed on p D729

Detonation Wave, Metastable. See Ref 52, p 51 and under Detonation Wave, Transients in Propagation; Transient, Anomalous, and Metastable (Unstable) Detonation Waves

Detonation Wave, Nonideal. See under Detonation, Ideal and Nonideal and in Ref 52, pp 48-50

Detonation Wave, Nonsteady and Steady. See under Detonation Wave, Steady and Nonsteady

Detonation Wave, Nuclear is briefly discussed in Ref 21, listed on p D725

Detonation Waves, Oblique. Under this term are known waves formed on the initiation of an explosive charge by the oblique impact of a metal plate

Sanyukovich (Ref 14) obtained oblique waves and investigated flow of detonation products in the case of such waves. Sternberg & Piacesi (Ref 91a) investigated interaction of such waves with iron

David et al (Ref 93) investigated formation of oblique and overdriven detonation waves

by an oblique impact of a layer of explosive by a metal plate. When the metal plate came in contact with the layer of explosive, not all at once but gradually, an oblique detonation wave was initiated. The possible configuration of flow was studied in the neighborhood of the point of impact in two-dimensional plane geometry. Under certain conditions it was shown theoretically, that the compatibility at the interface could be achieved only by taking into account an *overdetonation* wave of given characteristics

An experimental arrangement is illustrated in Fig 1. on p 381 of Ref 93. A metal plate thickness ϵ , is bent through an angle ϕ , by means of a detonation wave, velocity D_0 travelling through a layer of explosive. When the plate was deflected, it hit at an angle of incidence i a block of explosive, density ρ_0 . The thicknesses were sufficiently small compared to the other quantities so that the flow could be considered as plane two-dimensional and stationary. The reference system R had its origin at the point of impact I and was under uniform linear motion. Theoretical and experimental studies of the flow were carried out in the vicinity of the point of impact

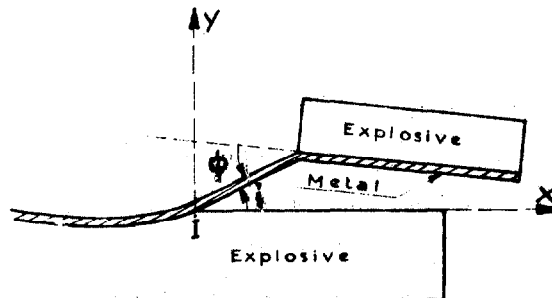

Fig 4 - Experimental arrangement

Two theoretical methods were used. The 1st one assumed that detonation occurs at the instant of impact (simplified method), while the 2nd took into account the time for the detonation to build up (method of prestressing shock). Results of calculation are given on pp 382-83. Figs 2 & 3 show pressure-deflection curves and flow diagrams for simplified method, while Fig 4 gives pressure-deflection curve and flow diagram for method of prestressing shock (Figs 2,3 & 4 are not shown here)

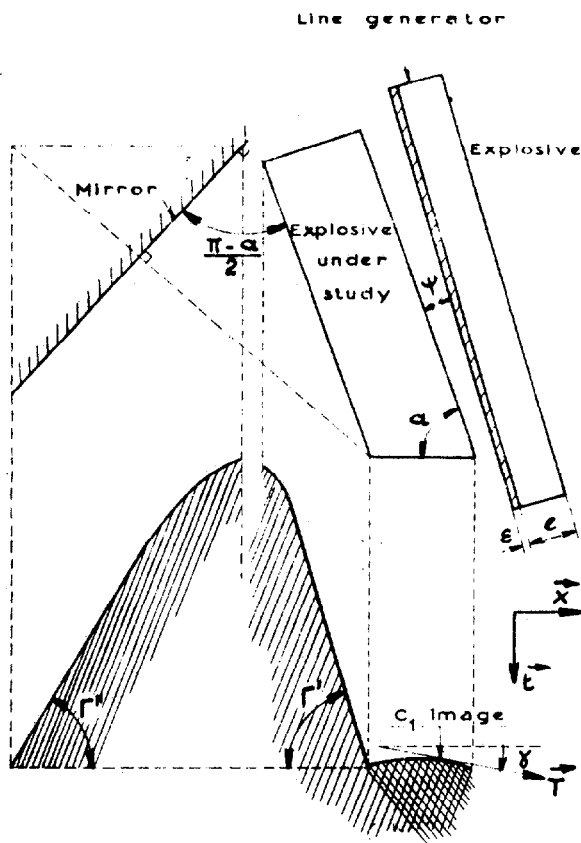

Fig 5 - Photographic arrangement

Fig 5 (shown here) shows experimental layout and the type of recording made on photographic plates. In the experiments, copper was projected by means of an explosive of detonation velocity D , of initial density ρ_0 which varied from experiment to experiment. Photographs of luminosity produced when using simplified method are given in Plates 1 & 2 of p 385 (These plates are not reproduced here)

The experiments of David et al showed that overdetonation took place at impact. The simplified method seemed to give a reasonable account of observation within experimental error, in so far as a solution was possible. When this method offered no solution, experiments showed that the overdetonation shock was very strong and it seemed that the shock suffered a large discontinuity as investigators went from the determinate to the indeterminate case. No observation could be made of the pre-stressing shock in the photographs and this was probably due to the smallness of the induction region

The following refs were listed in paper of David et al: 1) T. Camion, MAF 2, p 357 (1962), and 2) J. Berger et al, AnnPhys [13] 5(1960)

Detonation and Reaction-Waves, One-Dimensional .

These are ideal models of detonation waves in which all the physical props vary with only one coordinate which is normal to the wave front

Evans & Ablow (Ref 66) described the following one-dimensional waves: "One-dimensional Steady-State Reaction Waves with Instantaneous Reaction" (pp 137-45); "One-Dimensional Steady-State Reaction Waves with Finite Reaction Rate" (pp 146-55); and "One-Dimensional, Transient Reaction Waves" (pp 167-71)

A brief description is given at the beginning of this section under DETONATION (AND EXPLOSION) WAVES, where Fig 2 is shown; and under Detonation Wave, Steady-State, One-Dimensional, Plane"

See also under "DETONATION WAVES: STEADY-STATE, ONE-DIMENSIONAL, REACTION WAVES WITH INSTANTANEOUS REACTION", and under "Detonation Waves, Transient, One Dimensional"

One dimensional deton waves are also described in Refs 51, 52, 59, 77a & 93a

Detonation Wave One-Dimensional Approx-

imation. This subject was discussed by Lewis & Friauf (Ref 1a) and also in the book of Lewis & vonElbe (Ref 66a, p 512-24)

Detonation Wave, Overboosted. See Detonation (Overboosting in, p D462 and in Ref 30

Detonation Waves, Overcompressed and Under-

compressed. Zel'dovich and Kompaneets stated (Ref 60, pp 97-100), that Aivazov & Zel'dovich. (Ref 16), obt'd an "overcompressed" detonation wave by forcing a gaseous detonation wave to pass from a wide pipe into a narrow one. Such a wave is formed in the narrow pipe as a result of elevated pressure formed in the wide pipe upon reflection from the transition point.

The calculation of parameters of overcompressed wave formed on detonation of $2H_2+O_2$ mixture, has shown that upon transition from the wide pipe to the narrow one, an overcompressed wave should arise in the narrow pipe for which the pressure is 1.36 times greater than the pressure in the normal detonation wave. In this case the velocity of overcompressed wave was equal to 1.04 times the vel of normal deton wave, but

the difference in vels was too small to be reliably established experimentally. For the proof of the fact that the wave passing from the wide pipe to the narrow one was actually overcompressed, experiments were performed in which the collision of an overcompressed wave with the normal one was recorded. The pressure difference between the two waves gave rise to a marked assymetry in the reflection and this became clearly evident when recorded. From the ratios of the reflected wave velocities, it was not difficult to determine the pressure of the overcompressed wave

Overcompressed detonation waves were also observed by Troshin (Ref 55, p 789). He observed it not only in transfer of deton from the broad to narrow tube, but also immediately after transition of combustion to detonation. In his Fig 1 of the Hugoniot curve, shown on p 789, the JM branch corresponds to overcompressed detonation waves

The possibility of the existence of *under-compressed waves* is discussed by Zel'dovich & Kompaneets (Ref 60, pp 1.01-02). They connect the under compressed waves with an external artificial ignition, since in this case there is no igniting shock wave, and the molecular thermal conductivity of the combstn products from a raw mixt does not guarantee a sufficient vel of propagation of the regime. In principle, it is possible to represent the propagation of a reaction by a mechanism connected with the transmission of electrons or of light quanta. Such a mechanism could lead to a propagation vel larger than D in which case an undercompressed detonation wave would be realized. However, the fraction of the reaction energy which is converted into radiation energy is very small in all chem reactions at atmospheric pressure. Besides, expl mixts under initial conditions are so chem inert that a large concentration of energy is reqd for chem reaction to be initiated; therefore, in practice such a mechanism can never be realized accdg to Z & K

Detonation Wave, Overdriven - or Supported, Overdetonation Wave. These terms mean that the velocity and pressure of detonation are higher than calculated values for normal waves, known as Chapman-Jouguet waves. An over-

driven wave can be produced by several methods, such as:

- 1) When two cylindrical charges of expls of different brisance and power (such as HMX and Tetryl) are placed end to end and HMX is detonated, the detonation wave in Tetryl will be, for a certain length, at a higher velocity and pressure than is normal for Tetryl. Such a wave will be known as "overdriven" or "supported" by HMX (Ref 108)
- 2) A detonation may be driven to a rate higher than normal by "overboosting". The action is like a piston (in a shock tube), which would act on the products as constraint forcing them forward at a velocity higher than the C-J particle velocity. If the constraint were suddenly removed, the "overdriven" detonation would be expected to return to the normal rate. In some cases, it may remain above normal for a long time (Ref 51, p 284). In experiments conducted by Deffet et al (Ref 28a), two expl compns were used in 22-mm diam columns. In this diam, one compn detonated at 3250 m/sec, while the other at 1970. A 10-cm column of the 1st was used to booster a 25-cm column of the 2nd. In this case the deton vel averaged 2234 m/sec at 5-15 cm, and the normal vel of 1970 was not reached even after 25 cm. Persistence of higher than normal vel over such a distance in this expl was attributed to its consisting of a non-gelatinous mixture of NG & Na bicarbonate (Ref 28a). When a slower expl was used as a sheath around an 18-mm-diam core of the fast expl, so that the overall diam was 36mm, deton in the core proceeded 30mm before the sheath took any part whatever in the deton process. It was simply dispersed in the same manner as an inactive sheath, though the NG in it seemed to be in the state of low-velocity deton at 400 m/sec. Following this initial period, ca 10 microseconds, the NG in the sheath detonated suddenly in the usual way but at higher than normal deton vel (Ref 28a, and Ref 51, p 284)
- 3) In the experiments of Holland et al (Ref 46a), as cited by Dunkle (Ref 51, pp 202 & 284), a large single crystal of PETN was initiated by a plane deton wave generated

in a 2-inch thick piece of Comp B and attenuated by passage thru a 1-inch steel plate before using it for initiation. After a period of low-order deton at 5560m/sec the deton rate changed abruptly ("jumped") to 10450 m/sec accompanied by observable radiation in the interior of the crystal. Then a final apparently steady, deton was established at 8280 m/sec

4) Skidmore & Hart (Ref. 88) produced overdriven detonation waves in Comp B carrying increased velocities and pressures up to twice the C-J pressure by an explosive driven plate impact technique. The basis of the technique is to explosively propel a metal driver plate at a similar target plate on which rests a sample layer of expl backed by a further layer of inert solid. When the driver plate vel is sufficiently high this process generates a steady overdriven deton wave in the expl unless (or until) it is overtaken by the rarefaction wave from the rear of the driver plate.

The shock transit times thru each layer of the system are measured to determine the transmitted shock or detonation velocities. The measured driver plate impact vel or the shock vel in the target plate, whose shock properties are known defines the incident shock strength. An impedance match at the target plate - explosive interface using the measured overdriven detonation vel then defines the corresponding detonation pressure and particle velocity. The properties of the reflected waves in the deton products are determined by a similar impedance match at the explosive-backing plate interface using the measured transmitted shock velocity in the backing plate when the Hugoniot curve is known

In the 1st series of tests deton vel was detd as a function of particle vel at three deton pressures of ca 350, 420 & 520. kb. These pressures were generated by using a plane wave initiated 5-inch diam 5-inch

long cylindrical chge of 75/25-HMX/TNT to propel driver plates of mild steel 4.8-mm thick, brass 3.2-mm thick and mild steel 1.6-mm thick against a target plate of the same material. The target plate supported three 30-mm diam cylindrical expl samples (60/40-Comp B, $\rho = 1.65\text{g/cc}$, $D_{C-J} = 7740$ m/sec $P_{C-J} = 257\text{kb}$ and $U_{C-J} = 2010$ m/sec in a four-fold symmetric array with centers on a 25-mm radius circle. The target plate free surface vel was measured in the 4th location. Pin probes were used to record various transit times giving the driver plate impact vel, together with the target plate shock and free surface velocity as a consistency check and the deton vel in the expl sample, 3.2 and 6.4-mm thick. These samples served to detect possible shock attenuation effects which could invalidate the analysis. No such effects were observed. The mean results for each pressure are given in Table 1

Table 1

Mean Results for Overdriven Detonation Waves in Comp B

| Detonation Velocity, D m/sec | Detonation Pressure, P k/bar | Particle Velocity, U m/sec |
|---------------------------------|---------------------------------|-------------------------------|
| (C-J) 7740 | (C-J) 257 | (C-J) 2010 |
| 8000 | 346 | 2620 |
| 8280 | 412 | 3020 |
| 8930 | 520 | 3530 |

In the 2nd series of tests shock compressions and adiabatic transitions from a deton pressure of 420kb were examined using the brass driver plate and measuring the transmitted shock vel in 3.2-mm thick expl samples. The matching materials were tungsten alloy, Ni, brass, Ti, Dural, Mg, Perspex and air at 1 atm. In some of the later experiments the geometry was changed from discs to quadrants to obtain an improved probe coverage over a larger surface area. The mean results of these tests are given in Table 2

Table 2

Mean Results for Reflected Waves in
Overdriven Composition B

| Matching Material | Density, g/cc | Shock Velocity, m/sec | Pressure, k/bar | Particle Velocity, m/sec |
|-------------------|-----------------------|-----------------------|-----------------|--------------------------|
| W-alloy | 16.8 | 5020 | 818 | 970 |
| Ni | 8.86 | 6460 | 716 | 1250 |
| Brass | 8.44 | 5790 | 689 | 1410 |
| Ti | 4.51 | 6870 | 604 | 1950 |
| Dural | 2.65 | 8520 | 522 | 2310 |
| Mg | 1.74 | 8120 | 407 | 2880 |
| Perspex | 1.18 | 7770 | 332 | 3620 |
| Air | 1.29×10^{-3} | 1027 | 1.26 | 9500 |
| Comp B | 1.65 | 8400 | 420 | 3030 |

Some of these values are plotted in Figs. In Fig 1, p 50 of Ref 88, the overdriven deton velocities are plotted as a function of deton pressure and compared with the predictions of theory; while in Fig 2, p 51, the corresponding comparison is made in the pressure-particle velocity plane. Also in Fig 2 the reflected wave data are compared with those obtd by theory

5) David et al (Ref 93) obtained overdetonation when investigating oblique detonation waves (See under Detonation Waves, Oblique)

Detonation Waves, Parameters (Characteristics)

of. Under the heading "Calculation of Detonation Parameters," Kistiakowsky Ref 24, pp 955-57 discussed briefly calculation by the hydrodynamic theory of the following parameters: density - initial ρ_0 , and peak ρ ; peak pressure p ; temperature T (calculated), $^{\circ}K$; detonation velocity D , c - sound velocity, and u - particle velocity. As an example, he gave parameters of the detonation wave in TNT, as calcd by S.R. Brinkley & E.B. Wilson, Jr and by H. Jones

Table 3

Parameters of Detonation
Waves in TNT

| Parameters | Wilson & Brinkley | Jones |
|---------------------------|-------------------|--------|
| ρ_0 , g/cc | 1.46 | 1.50 |
| ρ , g/cc | 1.86 | 1.94 |
| Temp, $^{\circ}K$ (calcd) | 3200 | 3460 |
| p , kg/cm ² | 140000 | 205000 |
| D , m/sec (calcd) | 6640 | 6470 |
| D , m/sec (observed) | 7720 | 6620 |
| c , m/sec | 5210 | 5970 |
| u , m/sec | 1430 | 1750 |

Dremin & Pokhil (Ref 58) detd deton wave parameters in TNT, RDX, NG and NMe. Zubarev & Telegin (Ref 76) detd parameters in some condensed expls and Hazal & Comburini (Ref 78) calculated characteristics of explosion waves in pure and diluted Hydrazoic Acid

Detonation Wave, Plane. This is a detonation wave in which the front is flat. See under Detonation, Spherical-and Plane-Fronts, p D708

(See also under "Detonation Wave, Steady-State, Plane" and the following Refs 1a, 77a, 90, 91 & 93c)

Detonation Wave, Plastic. These waves are complicated by the fact that there is no longer a linear relation between stress and strain. A plastic wave does not maintain its form as it progresses but rather the front of increasing stress tends to become longer and longer, at least in normal cases. The reflection at a discontinuity resembles generally the reflection of an elastic wave. Reflection of stress wave at a fixed end in an elastic member gives rise to stresses & strains that are exactly double those in the incident wave

Properties of plastic wave, as well as of elastic wave were determined by Minshall (Ref 39) using pin contactors and crystals (See also Refs 85b and 92a) (Compare with Detonation Wave, Elastic)

Detonation Wave, Plate Velocities in Impulse Loading by. This subject was discussed in the paper entitled "Plate Velocities in Impulse Loading by Detonation Waves", presented by R.B. Clay et al of Univ of Utah at the Symposium on Shock Waves in Process Equipment Annual Meeting of American Institute of Chemical Engineers, Chicago, Ill (1957)

Detonation Wave, Predetonation Period in. Under the term of "predetonation period" is known the period immediately preceding the formation of detonation wave. This is also called "induction period" in which the expl transforms from deflagration into detonation

Shepherd (Ref 18) gave a discussion on "predetonation period" in powdered Tetryl of density 1.10 g/cc.
(See also under Detonation, Predetonation Phase p D482)

Detonation Wave, Pressure of. This subject was discussed in Refs 3, 7, 20, 32, 50 & 52 pp 32-5 and 265-70

Detonation Wave Pressure Influence on the Velocity of Deflagration of Smokeless Propellants was discussed by Apin & Bolkhovitinov in Ref 57

Detonation Wave, Profile of. See under Detonation Wave Shape and Density Properties and in Ref 52, p 91

Detonation Wave, Progress of. Following is the résumé of discussion given by Dunkle in Ref 51, pp 196-98:

In a sound wave, the material merely vibrates and passes its energy on to the next layer. The *detonation wave velocity* is distinguished from the variable *particle velocity* involved in the to-and-fro vibration. The latter, in turn, is differentiated from the physical movement of material with its resulting finite displacement, in the direction of advance of the pulse, at velocity u . This movement is in response to a finite pressure differentiation, with consequent irreversibility and increase in entropy.

In solids a *shock wave* transmits a stress of such intensity as to exceed the elastic limit

and cause permanent deformation. This may involve slippage of crystal planes, evidenced by such phenomena as twinning, or rupture and restoration of primary valence bonds. The "fro" part of the "to-and-fro" motion characteristic of acoustic vibration is prevented, in shock waves, by the "break-down" of the material", ie, change in structure with accompanying degradation of energy. In inert solids, such waves attenuate rapidly (25% per inch in steel and 15% in Al). In an explosive, on the other hand, the energy imparted usually suffices to "trigger-off" a rearrangement of atoms resulting in release of far more energy than was applied. The "breaking stress" is thus passed on to other molecules susceptible to such rearrangement. Behind the disturbance there is, instead of rarefaction, a strong pressure pulse due to the chemical change. Detonation gives, hence, a continuous compression as against the alternate compression and rarefaction in an elastic wave. Carl (Ref 4a, p 359) attributed this effect to the greater increase of detonation rate with density in an insensitive than in a sensitive explosive. The less sensitive explosive must be distorted and moved forward to a greater extent, to induce rearrangement

In the words of T.C. Poulter & D.B. Moore of Stanford Research Institute (as quoted from Ref 51, p 197); "A normal shock wave traveling in an inert medium is continually doing work on the medium through which it is traveling and hence is continually being attenuated and therefore decelerated. A detonation is a true shock pulse but one in which the energy lost in attenuation is being replaced by the energy released by the chemical reaction associated with the detonation process. The detonation velocity is therefore the velocity of a plane shock in the explosive through which it is traveling and in which the attenuation is just compensated for by the energy received from the chemical reaction. Consequently anything which tends to increase the attenuation will tend to decrease the detonation rate, and anything which tends to increase the energy received will increase the detonation rate"

A spherically expanding detonation wave,

initiated on the axis of a cylindrical charge, decreases in curvature until the front reaches the cylindrical surface. The curvature then, instead of decreasing indefinitely, soon reaches a constant value of *steady-state wave* form which thereafter propagates unchanged along the remainder of column. Behind the front, axial expansion produces *rarefaction* or *release waves* which cut into the products from the charge boundary and finally converge at the axis. By the time the front has moved ca 3 charge diameters the region of hot compressed gases has assumed the form of a cone of density: $\rho = \rho_0 D / (D - u)$, called by C. O. Davis, M.A. Cook and some others the *detonation head*

Detonation Wave, Propagation of was discussed in Refs 4, 7, 13, 26, 33, 37, 51, 52 & 89

Following discussion is taken in abbreviated form from Taylor (Ref 26, pp 4-9)

The theory of the propagation of the detonation wave was worked out first of all to account for observations made on the speed of gas explns and it is on the applications of physical and thermodynamical principles made then that are relied on to develop the theory of condensed expls. The earlier investigators attempted to account for deton in gases by identifying the velocities of propagation either with the mean molecular velocity [as did M. Berthelot, CR **94**, 149 (1882)], or with the velocity of sound in the reaction products [as did H.B. Dixon, Phil Trans **184A**, 97 (1893)]. Although these approx theories are now superseded, they have one important point in common with the modern hydrodynamic theory [which is described in our work under DETONATION (AND EXPLOSION) THEORIES] In each of the above earlier theories, the propagation of the wave was explained in terms of the physical properties of the products, rather than those of the undetonated expl. The true significance of this approach could not become apparent until A. Schuster [Phil Trans **184A**, 152 (1893)], suggested an analogy betw detonation waves and the "non-reactive shock waves", which

had been discussed by H. Riemann as early as 1860

In order to appreciate Schuster's conjecture, Taylor stated (Ref 26, p 5), that compressional or dilatational waves of small intensity are propagated in gases at the velocity of sound, which increases with rising temperature. Suppose that a column of gas is set in motion by accelerating a piston smoothly into it such as described here under 'Detonation, Shock Tube Technique Studies in'. We may approximate to the continuous movement of the piston by a discontinuous movement in which, over each element of time, the piston velocity remains constant with the value appropriate to the center of that time-element. The velocity is then a "staircase-function" of time, the length and height of the steps being small. Each step transmits a small compressional wave which advances through the gas already set in forward motion and heated by its predecessors, and therefore tends to overtake them. As a consequence, the velocity, pressure and temperature gradients in the front of the wave grow continually steeper with time, and in the absence of dissipative processes, such as heat diffusion and viscous transfer, must end by becoming infinitely steep. When such dissipative processes are present, they prevent the development of absolute discontinuities; but the relevant transfer-coefficients are normally so small that equilibrium in the *wave front* is reached only at extremely steep gradients. Such a wave, in which a finite effective discontinuity has developed, is known as the *shock wave* and the region of rapid (in the non-dissipative case, infinitely rapid) pressure-rise is called the *shock-front*. Once formed, the front advances with supersonic speed, the level of which depends on conditions behind. If the piston continues to accelerate, so also does the front. If the piston settles down to a steady velocity, the shock-front in the end does likewise. If, however, the piston decelerates, a wave of rarefaction is formed ahead of it. The front of this wave moves with the local vel of sound

relative to the gas at each point, and must therefore pass through the compression wave and overtake and weaken the shock-front, which accordingly loses speed. If deceleration of piston persists, this process of erosion of the shock-front will also continue, until the velocity in the end has fallen to the sonic level

From the above discussion it follows that the velocity of the front is determined not by conditions ahead, but rather by conditions behind. It also follows that the wave is unstable and cannot maintain itself, but depends upon support from a piston, in the absence of which it must degenerate into a sound wave. Stable deton waves, however, do regularly arise without supporting piston, if released chemical energy provides the necessary support, and this in some way prevents rarefactions which arise in the products from overtaking the shock-front

In spite of the fact that the above briefly outlined theory, was being applied with marked success to gaseous expls in a quantitative way, a rather vague non-quantitative conception of the corresponding process in condensed expls remained prevalent during the first decades of present century. During the First World War it seems to have become apparent that the hydrodynamic theory must apply to condensed expls as well as to gases, the difficulty in application being the formulation of an equation of state to describe the reaction products at very high pressures (many tens of thousands of atmospheres) and high temperatures (several thousands of degrees). It is also necessary to make corrections as far as possible for the effect of the complex chemical equilibria under the conditions of the explosion. From this point on, once these problems had been taken up and possible solutions found, the basis of the hydrodynamic theory for condensed expls was rapidly established.

Accdg to Taylor(Ref 26), the hydrodynamic theory is purely mechanical, and, like thermodynamics, "it has no curiosity". This is at once its strength and its weakness. It requires no hypothesis in

regard to the nature of the decomposition or reaction of the molecules present in the explosive but merely assumes that "explosion" does begin, and that the chemical energy liberated is sufficient to maintain the progress of the detonation wave. Then from the conservation of mass, the equations of motion and of the conservation of energy, it proceeds to derive the velocity of detonation waves and the other physical quantities defining the deton process such as the pressure & temperature of detonation, the specific volume of the products and their "streaming" velocity (particle velocity). From the physical point of view it is in most respects a satisfying theory; from the chemical point of view it is less satisfactory, for not only does it throw no light on the chemical reactions involved, but it ignores their existence so long as the requisite energy is forthcoming. It is thus to be considered as only the first stage in a long process of investigation. Nevertheless, it is evident that if the conditions in the deton wave can be calcd, a very considerable advance has been made and one which will assist considerably in the design of new expls and in their application

[See also under DETONATION (AND EXPLOSION) THEORIES]

Detonation Wave, Radius of Curvature of Its Front versus Velocity. The relationship between the velocity with which a detonation wave propagates axially along a cylindrical charge and the finite radius of the charge has been studied theoretically by Eyring et al (Ref 22a) and by Jones (Ref 18a). The objective of the work of Wood & Kirkwood described in Ref 36a is somewhat different, namely, to give an account of the *relation between velocity and radius of curvature of the wave front*, rather than the charge radius. The work of W. & K is closely related to the "Curved Front Theory" of Eyring et al, although the basic model, as well as the objective, is considerably different.

Some of the results of the paper, entitled "Structure of a Steady-State Plane Detonation Wave with Finite Reaction Rate," listed here as Ref 36 were used in that work (See p D726)

The model used in Ref 36a is a compressible, non-dissipative, adiabatic, reactive medium into which a detonation wave is propagated in steady state. The medium is a cylinder of indefinite length. A system of cylindrical coordinates is used with z-axis along the charge axis in the direction of propagation, and with r denoting the radial distance from this axis. The origin of z is taken as the position of the intersection of the wave front and z-axis at time $t = 0$. The cylindrical symmetry is assumed throughout the detonation, so that none of the variables depends on azimuthal angle, and all velocities lie in planes containing the z-axis. Under these conditions the equations of hydrodynamics, including the first law and the reaction rate law, become as given in equations 1a to 1f inclusive. Then follow eqs 2a to 2c incl, for calculating the Rankine-Hugoniot conditions and many other equations which finally lead to equation 35 giving *velocity deficit*;

$$(D^{(0)} - D)/D^{(0)} = 3.5 \xi^*/S,$$

where D = detonation velocity along the charge axis in the direction of wave propagation; $D^{(0)}$ = one-dimensional, steady-state, Chapman-Jouquet detonation velocity ξ^* = Chapman-Jouquet point and S = radius of curvature of the shock front

The authors stated that the above value should be regarded as only approximate and they hope in the near future to apply this theory to specific explosives

In the abstract of the paper (Ref 36a, p 1920) it is stated: The limiting slope of the detonation velocity-wave front curvature locus for small velocity deficits is obtained under an assumption concerning the "reaction zone length" as related to the charge diameter and the radius of curvature of the wave front. The model is an extension to two dimensions of von Neumann's classical theory of the plane wave detonation

Detonation Wave Shape and Density

Properties: This is the title of Chapter 5 in Cook's book (Ref 52 pp 91-122). On p 91, under the title "Theoretical Wave Profiles," Cook stated that the shape of the deton wave and the density-distance $\rho(X)$ as well as the particle velocity-distance $W(x)$ relations behind the wave front are of considerable importance. Langweiler (Ref 3a, quoted in Ref 52, p 91) assumed for the plane-wave case a simplified constant $\rho(x)$ and $W(x)$ contour followed by a sharp (presumably discontinuous) rarefaction. He gave as the velocity of the rarefaction front the value $(D + W)/2$, where D = detonation velocity and W = particle velocity. He also stated that in an explosion of infinite lateral extent, the compressional region or *detonation head* of wave should grow in thickness according to the equation:

$$s = [1 - (D + W)/2D] Dt = 3Dt/8 \quad (\text{Eq 5.1})$$

where s = thickness of ideal (perfectly confined) detonation head and t = time

In the Langweiler concept, no influence on velocity would be felt by any finite reaction zone of length less than $3Dt/8$, since $W'(x) = W_2$ (particle velocity at C-J plane) = constant, the C-J plane could arbitrarily be placed at the front of the rarefaction or at any other plane between this and the wave front without any influence on the velocity. Moreover, for any value of reaction zone length $a_0 < s < 3Dt/8$, the velocity at the distance Dt from the point of initiation would be ideal ($D = D^*$). Only for $a_0 > s$ would detonation become nonideal in the Langweiler model, but in this case the effective reaction-zone length would be just $3Dt/8$, and $D(t)$ would thus be transient until $a_0 \leq 3Dt/8$

Cook considered the influence of finite charges on a simplified model by postulating the existence of *lateral rarefaction waves* (called *release wave* by E.M. Pugh) from the sides of the charge. He also assumed that they converged on the central axis with a sharp or discontinuous front of the same velocity as in Langweiler

rarefaction from the rear. This simplified model predicted the development of a steady-state detonation head after propagation of the wave front in unconfined cylindrical chges a distance of ca 3.5 chge diameters ($L_m/d = 3.5$, where L_m is maximum effective chge length) from the point of initiation. The deton head would develop thru stages of successive truncated cones of base to apex height ca $3Dt/8$, reaching a fully developed cone of ca one chge diam height. In confined chges the steady-state deton head should, in this model, be somewhat larger because confinement would lower at least the initial velocity of the release waves from the side. The detonation-head development and its steady-state form in confined and unconfined chges are illustrated in Fig 5.1 of Ref 52, p 92 (which is also reproduced here) taking into account the spherical shape of wave front

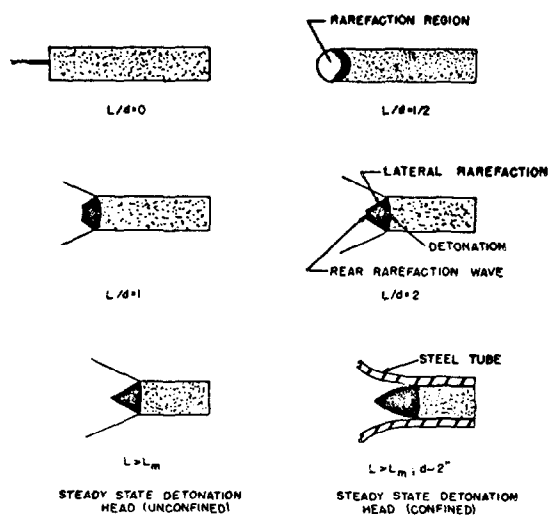

Figure 5.1. Development of detonation head.

The Langweiler model was attacked by Kistiakowsky & Kydd (Ref 45) on the basis that the rarefaction wave cannot remain abrupt but must spread out in time. In all classical treatments it is assumed that rarefaction begins immediately behind the deton front. For later considerations the quantitative impulse I , the kinetic energy T relations and total mass M of the deton head for this model are given in Ref 52, p 91 as equations 5.2, 5.3 & 5.5. The equation 5.4 gives $F(L)$ which

is the function defining the growth of deton head. These equations must be modified to take into account confinement

Taylor (Ref 23, as quoted in Ref 52, p 92) studied theoretically the $\rho(x)$ and $W(x)$ distributions behind plane and spherical deton waves for gaseous expls and TNT, using the hydrodynamic relation (Eq 5.6, p 92 of Ref 52), which may be integrated to give for gaseous expls;

$$W = f(\rho W_2), \quad (\text{Eq 5.7})$$

where W = particle velocity; W_2 = particle vel at C-J plane, f = function and ρ = density of expl

For condensed expls equation 5.8 is given which may be written as:

$$W - W_2 = \int_v^{v_2} \frac{(nRT\beta)^{1/2}}{v-a} dv = W_2 \beta \int_v^{v_2} \frac{dv}{v-a} \quad (\text{Eq 5.8})$$

where a = covolume; $\beta = (v-a)/(v-v_0)$; v = specific volume of original expl, and v_2 = sp vol at C-J plane

Eq 5.8 is applicable in the range $v_2 < v < v_1$, ie between the C-J plane and the stagnation plane $W(x) = 0$. The approximation in Eq 5.8 is based on the observation that in this range of densities, ρ , the T decreases during isentropic expansion at about the same rate that β increases and the product $(T\beta)$ is therefore approximately constant. The integral $\int_v^{v_2} dv/(v-a)$ is apparently the same for a given initial and final density for at least most condensed expls since $a(v)$ is the same function of v for these expls. Thus it is evident that the condition in Eq 5.7 applies to condensed as well as gaseous expls. $W(x)$ and $p(x)$ may thus be studied in the general case by observing simply the $\rho(x)$ distribution. That is $p(x)$, $W(x)$, and $\rho(x)$ should all vary in about the same way, and the measurement of one serves thru the hydrodynamic theory to define the other two

Further work of Taylor is described by Cook on pp 92 & 93 who also lists Eqs 5.9 & 5.10 derived by Taylor for the ideal isentropic gas

The works of W. Doering & G. Burkhardt (listed as Ref 5 in Cook, p 122) and of H. Pfriem are briefly discussed by Cook on p 93. Doering & Burkhardt developed the following relation for the $\rho(x)$ in gaseous explosions:

$$\rho(x)/\rho_2 = \left(\frac{\gamma-1}{\gamma} \cdot \frac{x}{Dt} + \frac{1}{\gamma} \right)^{2/(\gamma-1)} \quad (\text{Eq 11})$$

for $\rho_2 > \rho(x) > \rho_f$ where ρ_f is the density in the stagnation region ($0.5 < x/x_0 < 1.0$).

Hence ρ_f is given in this model by:

$$\rho_f = \rho_2 \left[\frac{\gamma+1}{\gamma} \right]^{2/(\gamma-1)} \quad (\text{Eq 11a})$$

In Eqs 11 & 11a, γ is equal to 1/3

The above mentioned theories of Langweiler, Taylor, Doering & Burkhardt and Pfriem did not take into account the influence of lateral expansion and/or heat loss. In condensed expls, edge effects prevent ideal conditions from applying more than about one charge diameter along the axis of a cylindrical charge and shorter distances

off the axis. Even under the maximum available confinement, these idealized conditions cannot apply in condensed expls appreciably more than one diameter behind the wave front even on the charge axis. Fig 5.2 given on p 94 of Ref 52 illustrates diagrammatically the influence of lateral rarefaction (or release waves), in a more general case than the Langweiler one, ie, one with at least some variation in $\rho(x)$ for $W(x)$ positive. Here the dotted lines represent constant $\rho(x,y,z)$, $W(x,y,z)$ and/or $p(x,y,z)$ contours, the rate of change betw successive contours being indicated by the density of spacing of the contours. The heavy line outlining the triangular region observed in flash radiography corresponds to the region of the sharpest rarefaction. Fig 5.2 is based on what Cook considers the best experimental evidence for the $\rho(x,y,z)$ relations in the detonation head

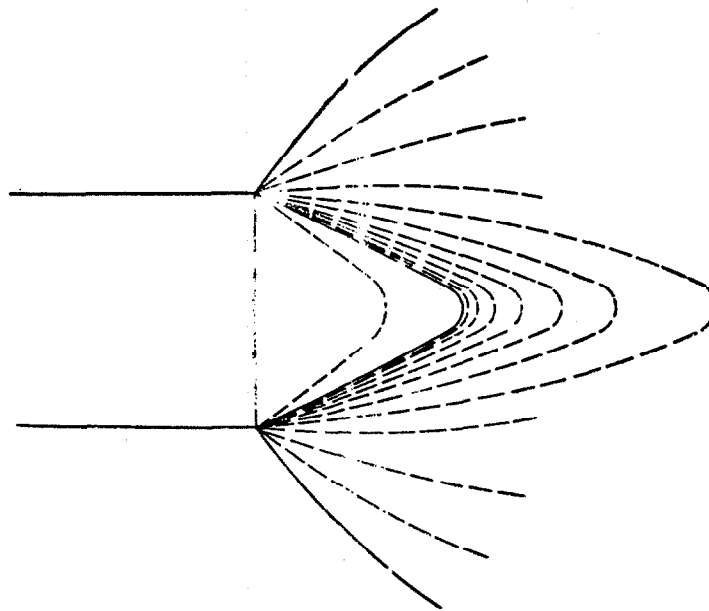

Figure 5.2 The phenomenological model of the detonation head in an unconfined cylindrical charge

The $\rho(x)$ curve for gases was investigated by Kistiakowsky & Kydd (Ref 45), using the time-resolved (continuous) radiographic method. The observed $\rho(x)$ curves were superficially in agreement with Eq 5.11 (given on p 94 of Cook's book (listed here as Eq 11) and the condition $\rho(x) = \text{constant}$ for $x > 0.5 x_0$ (where x_0 is the total distance from the wave front to the point of origin and x is the distance measured from the wave front to a particular characteristic behind the wave front). However, their results showed significant deviations from the theoretical predictions and this is explained by Cook on p 94

On p 97, Cook stated that in summary of the observations in gases the following conclusions seem justified:

- 1) There is an anomalous (approx flat) region observed in $\rho(x)$ and $p(x)$ measurements immediately following the detonation front which (over a limited range of propagation) seems to grow in time (or with distance) from the point of initiation
- 2) Eventually a steady-state head is developed after which the Taylor-Doering-Burkhardt-Pfriem conditions no longer apply, but instead the $\rho(x)$, $p(x)$, and $W(x)$ contours seem to become steady and
- 3) The Taylor-Doering-Burkhardt-Pfriem conditions seem to apply approximately in sufficiently early stages of propagation of detonation wave only behind the anomalous region

Under the title "Experimental Detonation Head in Condensed Explosives", Cook (Ref 52, pp 97-9) stated that the triangular region illustrated in Fig 5.2 for unconfined cylindrical charges has been observed in flash radiography at BRL, Aberdeen PG, Md and also in Germany. These radiographs showed clearly the importance of *release waves* in unconfined charges and, moreover, demonstrated that these waves have a fairly sharp front of velocity very close to the value $(D + W)/2$ of the Langweiler theory. However, only qualitative measurements of $\rho(x)$ have been possible from flash radiographs owing to blurring and nonuniformity of the X-ray burst. It has also been shown by a number of experiments involving *end*

effect (eg the impulse loading of a target at the end of a cylindrical charge) that a steady-state detonation head is developed in all condensed expls, whether confined or unconfined. It has also been shown that the steady-state condition depends primarily only on the geometry of the charge and is nearly independent of density and composition

Under the heading "Wave Front", Cook (Ref 52, p 99), reported that in many discussions of stable detonation waves, plane wave fronts are assumed to exist.

Actually, stable, plane wave fronts do not exist, at least in condensed explosives, as was shown by Cook et al (Ref 44a)

Below are summarized some of the important results of their studies (Ref 52, p 99):

- a) The wave front emerging from the unconfined cylindrical charge, was in general a spherical segment, both in ideal and nonideal expls, except at the very edge of the charge where slight edge effects were sometimes observed. Fig 5.6e shows sphericity of wave front for Amatol, Ammonium Nitrate and TNT charges of various diameters
- b) The radius of curvature R of the spherical wave front for *point initiation* of a cylindrical charge increased at first geometrically ($R = L$) but quickly settled down to a constant or steady-state value R_m significantly at $L \leq L_m$

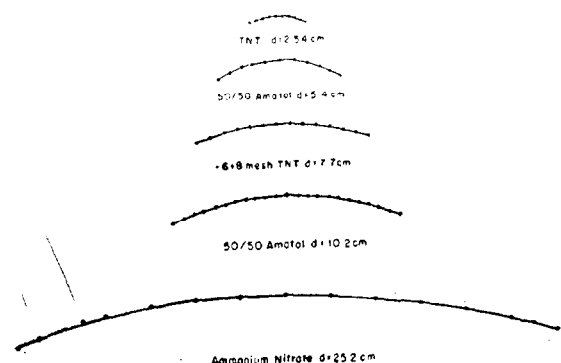

Figure 5.6e
Representative plots of reduced data showing sphericity of wave front

c) The steady-state curvature-diameter ratio R_m/d varied from ca 0.5 at the critical diameter d_c to a maximum of 3 to 4 at $d \gg d_c$. The max values of R/d in ideal deton were observed only at diams well above d_m^* (which are minimum diams). The unconfined critical diam for propagation of the deton wave varied from about the edge effect value 0.6 cm (for ideal expls of very high reaction rate) to very large values, 10 to 15 cm (for nonideal expls of low reaction rate, such as AN)

d) The wave shape observed at large L/d was independent of the type of initiator used or the initial wave shape. While one may, by the use of appropriate wave-shaping boosters, initiate a chge to propagate initially with almost any desired wave shape, as L increases, the shape of the wave front quickly reverts to the steady-state spherical one of $R = R_m$ characteristic of the expl

In ideal expls R_m/d generally fell betw 2.0 and 3.5. Hence one makes no appreciable error in discussions of ideal expls to treat the wave front as plane. However, the assumption of plane wave fronts may entail difficulty in ideal expls of small charge length or in nonideal expls, particularly in discussions concerning the region of the critical diam where R_m/d approaches 0.5

The above facts permitted Cook et al to write the following equations pertaining to wave shape:

$$R_i(y_i) = \text{constant}; \quad y < y^l, \quad (\text{Eq 5.19})$$

where R_i = radius of curvature of the wave at a particular charge length and at a point on the wave front a distance y_i perpendicular to the charge axis; y^l is the effective radius of the charge (radius excluding the slight edge effect which did not exceed 2mm in any case). Eq 5.19 simply expresses the experimental fact that the wave front is, in general, spherical in shape. There is no question about the validity of this result, especially in large diam charges, eg where $d \geq 7.5$ cm, where the resolution is especially good

$$\begin{aligned} R &\cong L; & L < R_m; \\ R = R_m = \text{const}; & & L > R_m \end{aligned} \quad (\text{Eq 5.20})$$

Equation 5.20 expresses the facts shown in Figs 5.7a and 5.7b that the spherical wave front expands geometrically for a length nearly up to R_m and then settles down surprisingly rapidly at $L \sim R_m$ in at least some cases to the steady-state value R_m . For theoretical purposes the assumption of a sharp, discontinuous change from spherical expansion ($R = L$) to the steady state wave front ($R = R_m$) is reliable almost within experimental error, as indicated by the dotted horizontal lines in Figs 5.7a and 5.7b. The situation was particularly definite in the nonideal expls, coarse TNT and 50/50 - TNT/SN (where SN stands for sodium nitrate), in 5 - and 10-cm diams. In the cases of low density, fine-grained TNT and EDNA, where deton was well into the ideal region, the results indicated a more gradual change from geometrical expansion to steady-state wave shape. In RDX, 50/50-Pentolite and 40/60-RDX/Salt the change from geometrical to steady-state propagation was also quite abrupt. The steady-state wave shape may perhaps be described by the equation:

$$\begin{aligned} R_m/d &= 3.5; & a_0/d &\ll 1 \quad (\text{Eq 5.21}) \\ R_m/d &= f(a_0/d, X); & a_0/d &\text{finite,} \end{aligned}$$

that is, if one assumes the density effects to be associated with finite a_0/d . Here X represents yet unknown factors determining wave shape in the region of finite a_0 , possibly involving besides a_0/d , the density ρ_1 , and the detonation pressure p_2 . Eq 5.21 expresses the extensive R_m/d versus d results obt'd in the studies in Cook's lab. The problem in the interpretation of wave-shape results involves: 1) the elucidation of the factors included in X and 2) the determination of the function f . These functions had not been formulated at the time of publication of Cook's book (year 1958), but the nature of the unknown variable X and function, f , may perhaps be understood from the consideration outlined on pp 103-04 of Cook's book, but not included here

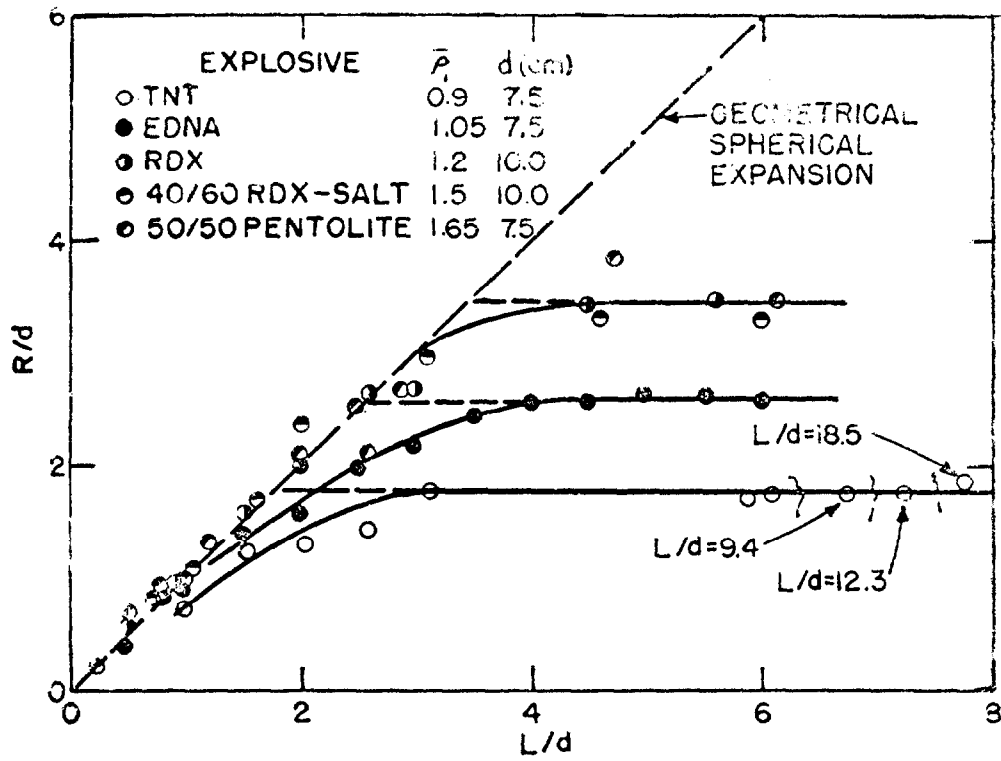

Figure 5.7a Variation of wave shape with charge length in ideal detonation

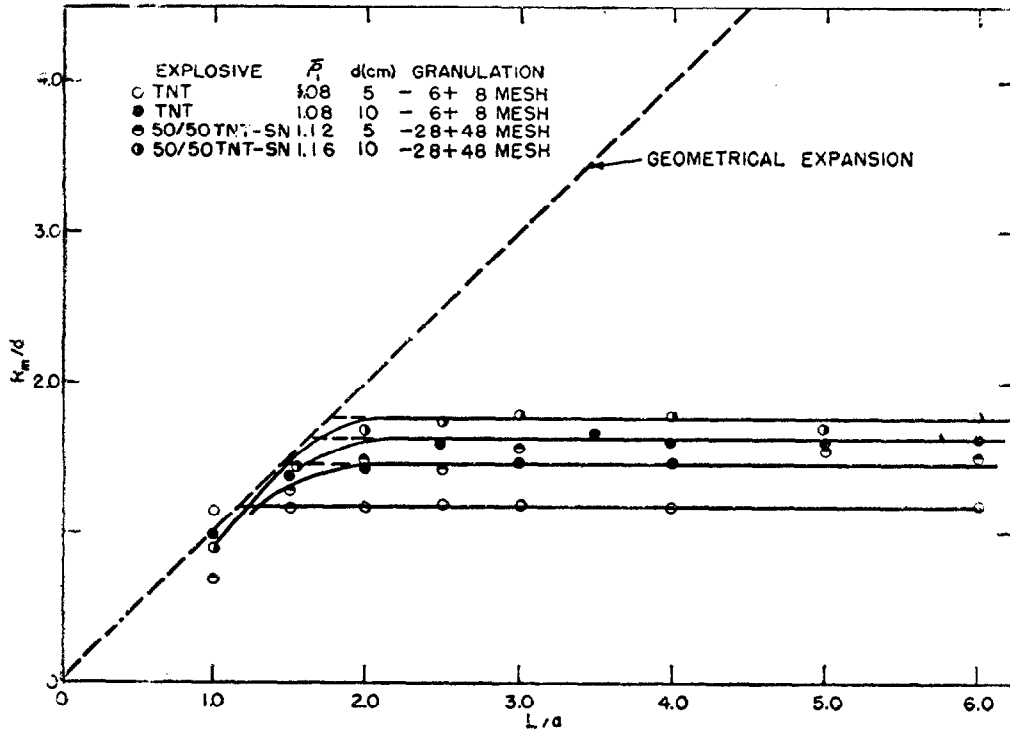

Figure 5.7b Variation of wave shape with charge length in nonideal detonation

The *detonation-head model* summarized by Cook on pp 105-06 & pp 120-22 is described here under Detonation (and Explosion), Initiation & Shock Processes. Detonation Head and Detonation Edge, p D417

In the same Chapter 5 of Cook are discussed: *Blast Contours* (pp 106-11), *Free Surface Velocity* (pp 111-16) [See our description under Detonation (and Explosion), Pressures of and Their Measurements, p 487]; and *Billard Ball Mechanism of $V_f(t)$* , (pp 116-20), where V_f is free-surface velocity and t is time. It was first described in Ref 48. Here the following treatment assumes a simple perfectly elastic collision mechanism of the detonation head, described by Eqs 5.2 to 5.5 (p 91 of Ref 52), (which are not listed here), with the plates in interpreting the $V_f(t)$ curves. Since the gases in this detonation head are at a density about 1/3rd greater than in the original expl, it is assumed that they are relatively incompressible and act in collision much like a solid. Therefore, the problem of hurling an inert object, such as a metal plate, may be treated in first approximation as a perfectly elastic (*billiard-ball type*) collision of the detonation head of mass M with a plate of mass M_p . A more refined analysis would take into consideration the compressibility, density and particle velocity variations in the detonation head. However, the simplified model of the *billiard-ball mechanism* seems to be adequate in handling not only the $V_f(t)$ problem but also end effects in general

In further discussion on the subject, Cook derived equations (5.28) (5.29) & (5.30). He also included the following Figs: Fig 5.18 Plate velocity, V_p versus plate mass relationships for 2-inch cylindrical charges of 70/30-Lead Nitrate/TNT & Tetryl at $L > L_m$; Fig 5.19 Plate velocity, V_p , versus M_p relations 2-inch cylindrical charge of Amatol and TNT at $L > L_m$; Fig 5.20 V_p versus M_p for Tetryl in 1-, 2- and 3-inch diameters at $L > L_m$; Fig 5.21 Kinetic energy versus M_p for 2-inch cylindrical charges at $L > L_m$; Fig 5.22 Comparison of theory with $V_p(M_p)$ unpublished results of M.L. Kempton & L.E. Gourley

for Composition C-4 block charges at $L > L_m$; Fig 5.23 Correlation of theoretical $V_p(M_p)$ curves with data of other investigators; and Fig 5.24 Plate velocity versus plate mass plotted in reduced units in terms of *Billiard-ball model*

Detonation Wave, Shaped. It deals with waves investigated by Jacobs & Grabenstetter, as described in Ref 12, listed on p D725

Detonation Wave, Spherical. Under this term are known detonation waves whose surface (front) is at all points equidistant from the center. The detonation wave front is in the form of a sphere and propagates outwardly in all directions

This subject has been described in the following Refs: 7, 32a, 59, 64, 71, 106 & 107

Taylor (Ref 23) stated that ignition of TNT chge at some point inside the expl, results in a very rapid drop in pressure & velocity behind the deton front. A fixed proportion of the whole vol of burnt gas is at rest and the radial rate of change of the variables: velocity, pressure & density become finite at the deton front. The fact that the velocity drops to zero at some point between the deton surface & the center shows that a spherical deton wave can maintain itself in the case of TNT. It is not known whether this is true in all cases

Lutzky (Ref 86) determined the "Flow" Field Behind a Spherical Detonation in TNT Using the Landau-Stanyukovich Equation of State for Detonation Products" [See also under Detonation (and Explosion), Spherical and under Detonation, Spherical Wave for the Gaseous Products of Solid Explosives in]

Detonation Waves, Spherically Symmetric Flow in the Steady Zone of. See under Detonation Waves; Steady-State, Three-Dimensional, Axially Symmetric

Detonation Wave, Spinning. See under Detonation (and Explosion), Spinning and in Ref 105, listed on p D730

Detonation Wave, Spread Around Its Initiating Point in High Explosives. See Refs 17 & 18, listed on p D725

Detonation Wave, Stability of was discussed in Refs 27, 70, 74 & 102

Detonation Waves, Stabilized- or Standing. See under Detonation Waves, Stationary-, Standing-, or Stabilized

Detonation Waves, Stationary-, Standing-, or Stabilized. Under these terms are known waves which remain stationary relative to laboratory coordinates

According to Nicholls et al (Refs 63, 69, 79 & 82) such waves can be attained when a gaseous combustible mixture in a flame tube or in a shock tube is accelerated to the appropriate velocity, pressure, and temperature conditions and then subjected to a shock wave. The ensuing complicated phenomenon can vary somewhat between different experimental environments or from similar results obtained in shock tubes. In order to understand the reasons for these differences so that the shock-combustion wave could be better comprehended, Nicholls et al, examined results previously reported in the literature and compared them with results obtained in their laboratory from shock tubes and ballistic range

Theory of stationary detonation waves was discussed by Kistiakowsky in Kirk & Othmer's Encyclopedia, Vol 5, pp 952-55 (Ref 24). Theory of structure and stability of deton waves was examined before 1952 at the USBurMines (Ref 27). Stability of detonation waves at low pressure was examined by Fay (Ref 74). In Russia stability of deton waves was examined by Zaidel (Ref 70) and by Istratov et al (Ref 102)

Detonation Wave, Steady Flow in .

Evan s & Ablow in Section II of their paper (Ref 66, p 131), entitled the *Nonreactive Flow*, defined the *steady flow as a flow in which all partial derivatives with respect to time are equal to zero*

Section II of the paper is subdivided into the following subsections:

A. Flow Equations; Equations of State; Sound Speed.

The differential equations of fluid dynamics express conservation of mass, conservation of momentum, conservation of energy and an equation of state. For an adiabatic reversible process, viscosity and heat conduction processes are absent and the equations are 2.1.1 to 2.1.13, inclusive

A steady flow is called *subsonic, sonic, or supersonic* at a point as the magnitude of flow velocity \vec{v} at that point is less than, equal to, or greater than the sound velocity at that point, in the particular coordinate system being used (Ref 66, p 131)

B. Hyperbolic Flow; Characteristic Equations.

The behavior of a reactive wave depends on the flow of its reacting and product-gases. The conservation laws lead to systems of partial differential equations of the first order which are quasilinear, ie, equations in which partial derivatives appear linearly. In practical cases special symmetry of boundary and initial conditions is often invoked to reduce the number of independent variables. The number of dependent variables is reduced by various assumptions on the form of solution. If the adiabatic flow equations 2.1.1 to 2.1.4 on p 131 are simplified to a pair of eqs in two dependent and two independent variables by assuming one-dimensional, homogeneous (uniformly isentropic) flow, eqs 2.2.1 to 2.2.7

Some linear combination of the two equations may permit a relation between derivatives of u and v , (which are components of material velocity factor \vec{v}) in the same direction, a so-called *characteristic direction*. A *characteristic curve* (or *characteristic*) is a curve which is tangent at every point to a characteristic direction

It is also shown that the one-dimensional, unsteady flow eqs 2.2.1 and 2.2.2 form a hyperbolic system with two characteristic directions, while the steady plane flow eqs 2.2.4 & 2.2.5 have the roots for

characteristic directions expressed by eq 2.2.9. The plane flow is hyperbolic where the flow is supersonic and elliptic where the flow is subsonic. Extended regions of sonic flow are not generally encountered. Detonations involve *transonic flows*, ie, flows that change type (Ref 66, p 132)

Identification of the characteristic curves is advantageous for the following reasons: (1) Weak discontinuities introduced at the boundaries are propagated into the flow along characteristic curves so that the characteristics are wave-front path (A weak discontinuity is a sharp change in a derivative of a function without any change in the function itself); (2) The boundary values influencing the flow at a given point are just those between the backwards characteristics thru the point. Thus the regions which a change in the boundary will and will not affect are defined by the characteristic curves; (3) The eqs in characteristic form are readily solved by finite difference methods

C. Hyperbolic Flow; Initial Value Problems

In many cases a flow is known as it crosses a certain initial line, 1, and the subsequent behavior of the flow is to be determined. Such an initial line may be the path of a piston along which velocity of material u is known, or the path of a shock wave along which p_1 , r_1 , and u , are known. From the given data, the *characteristic directions* along 1 may be computed using eq 2.2.7 (given on p 132 of Ref 66) and, in particular for *one-dimensional, unsteady flow*, eq 2.2.8. Different cases arise accordg to the relative directions of 1 and the characteristics thru 1. In general, the characteristic curves are not perpendicular to the flow direction so that there is a downstream or forward direction on the characteristic (Ref 66, p 133)

Evans & Ablow (Ref 66, p 134) show in a plot of space coordinates, x , and time coordinates, t , that there exists a *domain of dependence* which describes the flow

in the angular space between a spacelike initial curve on which both dependent variables are prescribed and an intersecting timelike curve on which one dependent variable is known. The flow is uniquely detd in two parts: 1) in the domain of dependence of the spacelike curve and 2) in the domain of dependence between the timelike initial curve and the last characteristic of the first flow. These curves are not reproduced here

D. Hyperbolic Flow: Simple Waves

In this subsection (Ref 66, p 134) a *continuous flow* is considered. This is a flow in which dependent variables vary continuously with position. In such a flow the characteristic curves in either the physical or the hodograph (the curve formed by the ends of vel vectors of a moving particle, when all vectors are drawn from a common point) planes (Ref 66, p 133) are also continuous, connected curves. The region in which the dependent variables have constant values, that is a region of uniform flow, is necessarily represented by just one point in the hodograph plane since, for example, in *one-dimensional flow*, u and ρ are everywhere the same. Thus those characteristics in the x, y -plane that cross from the uniform flow to an adjacent region of non-uniform flow are all represented by the single characteristic in the hodograph plane passing in the proper direction thru the point corresponding to the uniform flow. Such a flow represented by a single characteristic curve in the hodograph plane is called a *simple wave* (Ref 66, pp 134-35)

Evans & Ablow (Ref 66, p 135) show in Fig 4 an example of uniform & simple wave regions in the flow caused in a gas initially at rest when the confining piston accelerates to a constant receding speed. Region I is the initial undisturbed region of uniform density and zero flow speed. Region II is the simple wave covered by straight characteristics, and Region III is the final state of uniform density & flow speed accomodated to the piston motion

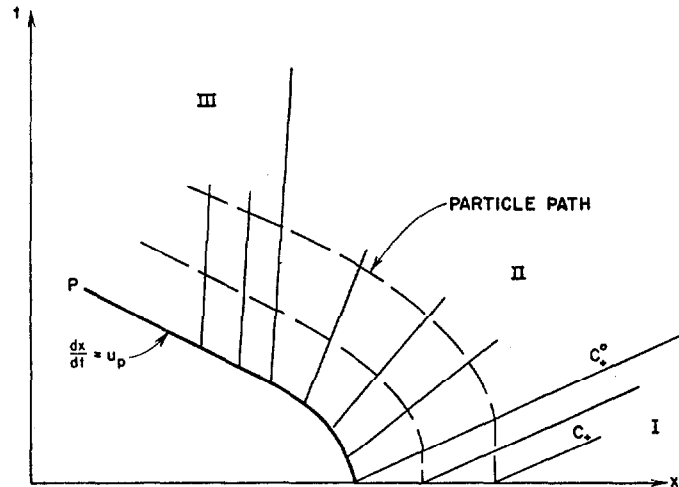

FIG 4. Straight characteristics and particle paths in a simple wave. Piston path (P), straight characteristics (solid), and particle paths (dashed) are shown.

E. Shocks

Accdg to Ref 66, p 135, the usual way of treating shocks is to idealize them to jump discontinuities, in this way taking into account the effect of the irreversible process caused by friction and heat conditions. It is assumed that the flow involving such a discontinuous process is completely determined by the three laws of conservation of mass, momentum and energy and the condition that the entropy does not decrease in the discontinuous process. Outside of the transition zone the flow is determined by the differential eqs 2.1.1, 2.2.2 & 2.2.3 listed on p 132 of Ref 66

There are two types of discontinuity surfaces: contact surfaces and shock fronts. There is no flow between regions separated by a contact surface, while shock fronts are crossed by the flow. A contact surface moves with the fluid and separates two zones of different density and temperature, but the same pressure. The normal component of the flow velocity is the same on both sides of a contact discontinuity

If subscripts 0 and 1 refer to conditions on each side of discontinuity, the jump conditions can be expressed by equations listed on p 136 of Ref 66

It should be noted that the flow velocity relative to a shock is supersonic ahead and

subsonic behind the shock. Thus, upstream characteristics behind the shock overtake it, while the shock itself overtakes the upstream characteristics ahead of it. This is sketched in Fig 5 on p 136 of Ref 66

The fractional increase in pressure across a shock $(p_1 - p_0) / p_0$ is the *strength of the shock*. The entropy change thru a shock increases with shock strength (Ref 66, p 137)

F. Interactions

Accdg to Ref 66, p 137, actually occurring one-dimensional flows often contain uniform and simple wave flow regions, shocks and contact discontinuities which move toward or thru one another. The interference of one type of flow with another leads to complex patterns requiring the general solutions of the conservation equations

Certain facts about interactions can be reached in an elementary way. Thus, two initially separate simple rarefactions have regions moving in the same direction, remain separate, because they are bounded by characteristics of the same kind which cannot intersect. If two simple waves moving toward each other separate three regions of uniform flow, as would happen if two pistons at rest at either end of a tube started away from each other with constant speeds, the waves will intersect each other in a

general flow region and pass on as simple waves, leaving a uniform-flow region of growing size betw them. This follows from the fact that only a simple wave can be adjacent to a uniform-flow region and that cross characteristics in a simple wave all lie on a single characteristic curve in the hodograph plane. Thus cross characteristics from two such waves can only intersect in a region of uniform flow, a single point of the hodograph plane

Since shock discontinuities move at supersonic speed into the fluid ahead, shocks overtake contact discontinuities and rarefaction waves. Since shocks move subsonically with respect to the fluid behind them, a shock will be overtaken by a shock or rarefaction behind it. When two shocks moving toward each other collide, two shocks moving away from each other are produced together with two regions of different entropy separated by a contact discontinuity thru the point of collision. If a shock collides with a contact discontinuity between two fluids, a shock is sent ahead into the 2nd fluid and a shock or rarefaction wave is reflected back into the 1st fluid. The kind of reflection depends on relative fluid densities and sound speeds and on the initiating shock strength. (Ref 66, p 137)

Detonation Wave, Steady-(Steady- State) and Nonsteady (Unsteady). Under the term *steady (or uniform or steady-state)* detonation wave is understood a wave propagating at constant parameters: velocity, pressure, specific volume, temperature and internal energy per unit mass. The nonsteady deton wave propagates at variable velocity, pressure, temperature, specific volume and energy per unit mass (See also Detonation Wave, Steady, One-Dimensional; Detonation Wave, Steady, Plane and Detonation Wave, Transient and Unsteady)

Detonation Wave, Steady, One-Dimensional
See Detonation Wave, Steady-State, One-Dimensional

Detonation Wave, Steady, Plane. See Detonation Wave; Steady-State, Plane.

DETONATION WAVES: STEADY- STATE, ONE- DIMENSIONAL REACTION WAVES WITH FINITE REACTION RATE

This subject is discussed by Evans & Ablow (Ref 66, pp 146- 57) in Section IV entitled: "One Dimensional, Steady-State Reaction Waves with Finite Reaction Rate". The section is subdivided into the following subsections:

IV,A. Existence, Uniqueness, and Mechanism of Propagation of Deflagration Waves. It is discussed on pp 146- 47, where equations 4.1.1 to 4.1.8 inclusive are listed, and Fig 16 and Fig 17 are presented. Fig 16 shows "Notation used in describing reaction wave of finite width", while Fig 17 gives "Family of Hugoniot curves $H(\epsilon) = J(\epsilon)$ with a Rayleigh - Mikhel'son line for a weak and for a strong deflagration"

IV,B. The Detonation Wave as a Discontinuous shock Followed by a Deflagration

This subsection is subdivided into:

1. *The Zel'dovich- von Neumann- Doering Model; The Chapman- Jouguet Hypothesis and Pathological Weak Detonations*

Accdg to Ref 66, p 147, it was postulated independently by Zel'dovich (our Ref 4), von Neumann (our Ref 6) and Döring (Doering) (our Ref 8), that a detonation is a reaction initiated by a shock. This contrasts with the gradual change of state guided by the reaction rate in deflagrations. They neglected transport effects within the detonation wave and came to the conclusion that a detonation wave is composed of an initiating shock followed by a deflagration in which the pressure and density decrease from $p_1; \rho_1$ to P_2, ρ_2 , where the subscript 1 indicates state behind shock (with fraction of reaction completed $\epsilon = 0$), and the subscript 2 indicates state with fraction of reaction completed $\epsilon = 1$

The Zel'dovich- vonNeumann- Doering theory is described here under Detonation, NDZ Theory, p D454

Chapman- Jouguet pathological detonation is briefly discussed on p 156 of Ref 66, where Fig 29 shows "Constant pressure, Chapman- Jouguet pathological detonation [See also under Detonation, Neumann's Pathological, p D457]

2. *Explicit Solutions of Equations for Chapman-Jouguet Detonations with Invariant Product Composition*

In this subsection Evans & Ablow (Ref 66, pp 148-50) describe the work of Eyring et al (Refs 9 & 22a) which includes equations 4.2.2 to 4.2.5 for a homogeneous explosive which relate p , t , u , and T within the wave to ϵ without reference to reaction kinetics. The variation of p , t , u , and T is shown diagrammatically in Fig 20 of Ref 66. Similar eqs were developed by Doering (our Ref 8). Paterson (our Ref 37a) developed eq 4.2.6 for a bimolecular reaction in an ideal gaseous explosive, which permits one to obtain the dependence of the variables on space or time. For nonhomogeneous expls, Eyring et al developed eqs 4.2.7, 4.2.8 and for 4.2.9, Paterson gave a detailed analysis of the behavior of the variables in a heterogeneous expl and developed eqs 4.2.10 to 4.2.18 incl

3. *Chapman-Jouguet Detonation with Varying Product Composition; Frozen Sound Speed*

These subjects are discussed by Evans & Ablow in Ref 66, pp 150-52 and in this Volume under Detonation, Sound Speed Frozen in, p D547

IV, C. **Steady Detonation Waves in Real Fluids.**

In Section IV, B (Ref 66, pp 147ff) it was postulated that a steady zone exists which consists of two parts which can be treated separately, the first a shock, the second a deflagration wave with the shock pressure and density as initial conditions. A more sophisticated approach is to avoid the postulate of a shock and instead to state the differential equations of conservation of mass, momentum, and energy to include more properties of a real fluid. Including the effects of viscosity, heat conditions, and diffusion along with chem reaction gives eqs with a unique solution for given boundary conditions and so solves the determinacy problem. The boundary conditions are restricted by the assumption that the reaction begins and is completed with the region considered. This implies that the space derivatives

are zero at both ends of the zone. The prescribed p , τ , and v are thus seen to satisfy the Rankine-Hugoniot conditions. The differential eqs in the interior of the wave express the same conservation laws, but take into account chem reaction and transport processes

Then follows the mathematical treatment which includes eqs 4.4.1 to 4.4.22 incl (Ref 66, pp 152-55)

This section is based also on the works of Friedrichs (our Ref 12a), Hirschfelder et al (our Ref 35a, p 797 & Ref 51b), Wood & Kirkwood (our Ref 45a) and Cook (our Ref 52, p 79 and Ref 43a)

DETONATION WAVES: STEADY-STATE, ONE-DIMENSIONAL REACTION WAVES WITH INSTANTANEOUS REACTION

Evans & Ablow gave in Ref 66, pp 137-46, Section III entitled: "One-Dimensional, Steady-State Reaction Waves with Instantaneous Reaction" a comprehensive description divided into the following subsections:

III, A. **Discontinuity Equations (pp 137-38)**

The restriction that no chem reaction occurs in the flow field is removed but consideration is limited to exothermic reactions. It is assumed that the chem reaction occurs instantaneously, so that the reaction zone is of zero width. Under this assumption the jump forms of the equations of conservation of mass, momentum, and energy are again justified

The mathematical treatment given by eqs 3.1.1 to 3.1.18 incl, is the same as is discussed under Rankine-Hugoniot Relations, p D 604 and Fig 6, showing "Hugoniot Curve $H^{(1)} = J^{(1)}$ of Reaction Products" (Ref 66, p 138) is given under History of Detonation Theories, p D606

III, B. **The Six Classes of Reaction Waves. Jouguet's Rule**

It was stated in Ref 66, p 139 that for a given set of initial and boundary conditions a steady-state reaction wave, if it exists, experimentally is usually found to have unique values of U (velocity of wave with respect to observer), u_2 (material velocity in x direction),

p_2 (pressure), τ_2 (specific volume) and T_2 (temperature in $^{\circ}\text{K}$); subscript 2 indicates state where $\epsilon = 1$ ($\epsilon =$ fraction of the reaction completed). (Certain exceptions are discussed in Ref 66, Sections III, E and V, B, 3)

Since the equations of continuity, momentum, energy, and state do not suffice to determine the five unknowns, it is necessary to inquire into the conditions under which solutions exist and whether solns are unique. The information which has thus far been omitted is a specification of the flow field of the reaction products, that is to say, since this section is restricted to one-dimensional flow, of the rear boundary condition. Before discussing the question of determinacy it is necessary to deduce from the equations of Section II of Ref 66, the general properties of flow ahead and behind reaction waves. To do this the Hugoniot curve for the products $H^{(1)}(\tau, p) = J^{(1)}$, (shown in Fig 6 of Ref 66) is divided into sections by considering the intersections with the Hugoniot curve of

a family of straight lines (known as *Rayleigh-Mikhel'son lines*) thru the point (v_0, p_0) . Here H is Hugoniot function, $J^{(1)} =$ heat of reaction $\tau =$ specific volume and $p =$ pressure; superscript (1) indicates state where reaction is completed, $\epsilon = 1$ and subscript 0 indicates state where $\epsilon = 0$. As the slope of the Rayleigh-Mikhel'son line intersecting the detonation branch becomes less negative, the two intersection points eventually coalesce at point C, which specifies a particular solution called the *Chapman-Jouquet detonation*. Solutions lying above the point C on the detonation branch are called *strong detonations*, while solns lying betw C and A are known as *weak detonations*. Similarly, the point of coalescence of the two intersections on the deflagration branch, point D, called the *Chapman-Jouquet deflagration*, separates a region represented by 1st intersections, the *weak deflagrations*, from a region represented by 2nd intersections, the *strong deflagrations*.

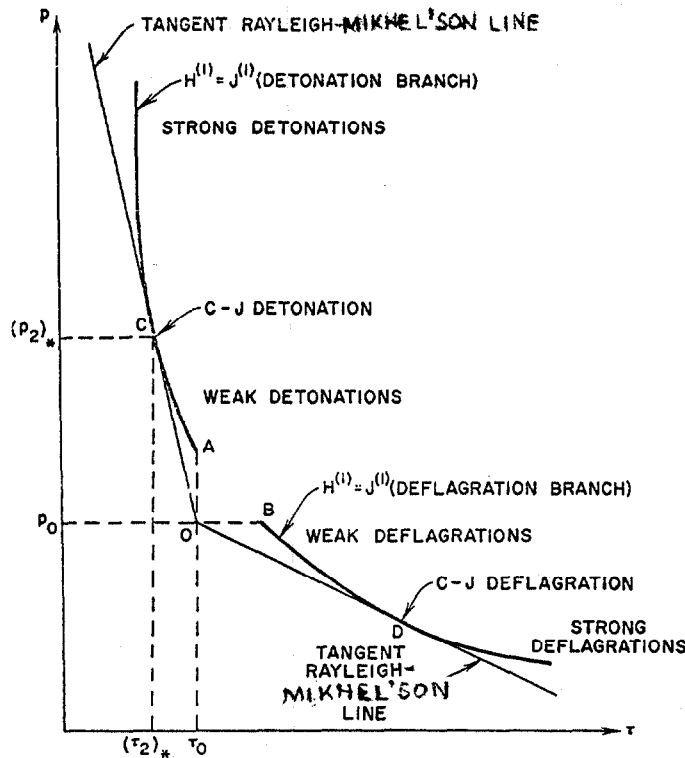

FIG 6 Hugoniot curve $H^{(1)} = J^{(1)}$ of reaction products, with sections corresponding to strong, Chapman-Jouquet, and weak detonations and deflagrations

Certain general statements can be made regarding the character of flow relative to the reaction front for the six classes of reaction waves, shown in Fig 6. The statements known collectively as *Jouguet's rule* are listed on p 139 of Ref 66 as (a), (b), (c), (d), (e), (f), (g) & (h); and also in this Volume under History of Detonation Theories, p D607

The above statements (a) to (h) are most readily proved for polytropic materials for which the equation of state has the properties enumerated on p 139 of Ref 66. Fig 7 shows a Hugoniot curve, Rayleigh-Mikhel'son (R-M) lines, and adiabats for such a system. Jouguet's rule is proved by showing that at a Chapman-Jouguet point the Hugoniot curve and the adiabat are both tangent to the Rayleigh-Mikhel'son (R-M) line and that at the regions of strong detonations and weak deflagrations the adiabats rise with increasing pressure more steeply, while in the regions of weak detonations and strong deflagrations less steeply with increasing pressure than the R-M line. On any R-M line any value of specific entropy s , where $(ds)_R = 0$ is a

maximum along that R-M line, so that there is at most along a R-M line one such stationary value of s , and, by equation 3.2.7 of H⁽¹⁾. This eq is:

$$(dH)^{(1)}_R = T(ds)_R$$

where the subscript R means differential along a R-M line

For the R-M line OF in Fig 7 this point of stationary and maximum s is indicated by point L. Thus s must increase along the R-M line at points of intersection betw A & C or B & D, and must decrease at points of intersection beyond C or D so that:

$$\left(\frac{ds}{dr}\right)_R < 0 \text{ at G \& J and } \quad (\text{eq 3.2.8})$$

$$\left(\frac{ds}{dr}\right)_R > 0 \text{ at F \& H } \quad (\text{eq 3.2.9})$$

Since at points C & D $(dH)^{(1)}_H = 0$, where the subscript H means differentiation along a Hugoniot curve, we obtain from eq 3.2.7:

$$(ds)_H = (ds)_R = 0 \text{ at C \& D (eq 3.2.11)}$$

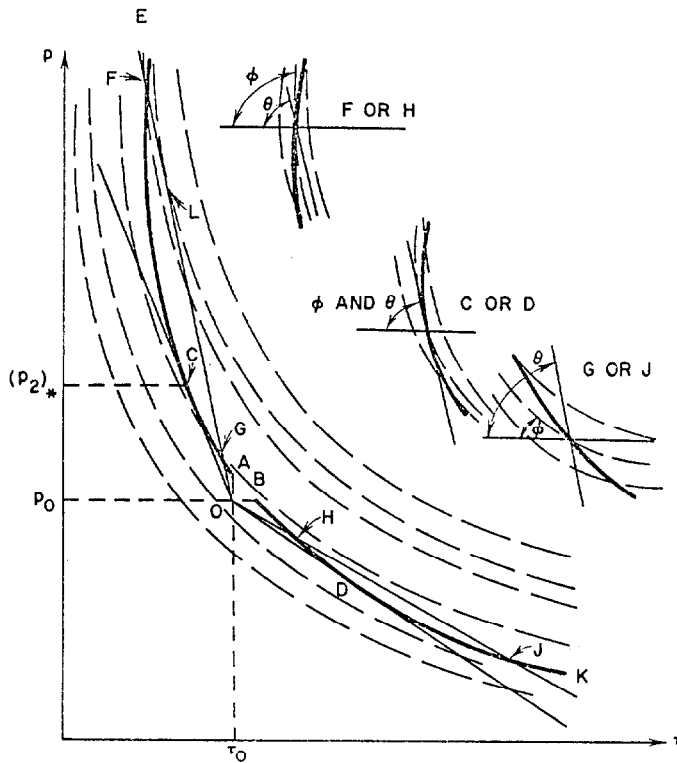

FIG 7 Hugoniot curve $H^{(1)} = J^{(1)}$ (heavy solid), Rayleigh-Mikhel'son lines (light solid), and adiabats (dashed)

This means that at the Chapman- Jouguet points the Hugoniot curve and the adiabat are both tangent to the Rayleigh- Mikhel'son line

Further on p 140 of Ref 66, Evans & Ablow gave proof to parts b, c, d, f, g & h of Jouguet's rule, listed on p 139, by introducing equations 3.2.12 to 3.2.17 incl. In order to prove parts a & e of Jouguet's rule, the state behind the discontinuity was fixed, while the state ahead of the front was varied. Applying relation $\theta > \phi$ at G & J of Fig 7 (where θ = angle betw the negative τ -axis and the R-M line and ϕ = angle betw the negative τ -axis and the tangent to the adiabat passing thru point on H ⁽¹⁾ = J ⁽¹⁾) and considering τ_0, p_0 as variable, with fixed τ_2, p_2 , the curve of Fig 8 was obt'd. The branch $QO'S$ is the locus of initial deflagration states, while the branch NOU that of initial detonation states from which the final state at G can be reached, where G represents any of the classes of final states shown in Figs 6 & 7. Along any R-M line such as GO or GO' of Fig 8, it remains true that the Hugoniot function and entropy have at most one stationary value each, and these values are maxima. The point of maximum entropy along $O'GO$ (point T) is shown in Fig 8 along with the adiabat thru T. A Rayleigh- Mikhel'son line can intersect a given branch of the Hugoniot curve of Fig 8 only once. Therefore at a point of intersection of the deton branch, $(ds/d\tau)_R < 0$, which is equivalent to $v^2 > c^2$, and at points of intersection along the deflagration branch QS , $v^2 < c^2$. This proved parts a & e of Jouguet's rule (Here v^2 = square of quantity (material vel - vel of wave) and c^2 = square of sound speed)

III, C. Existence and Uniqueness of Classes of Reaction Waves

This subject was discussed by Evans & Ablow in Ref 66. They subdivided this section into the following subsections:

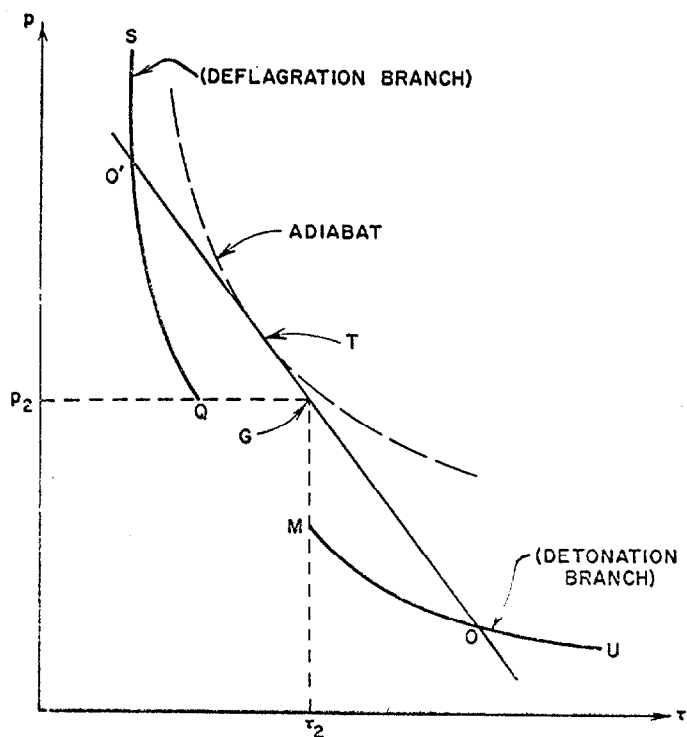

FIG 8 Hugoniot curve for given final condition p_2, τ_2 (point G)

1. Strong Detonations (p 141) and
2. Weak Detonations (pp 141-42)

Strong and weak detonation waves are described in our writeup under "Detonation, Strong and Weak", p D576

Possibility of weak detonation waves is described in Ref 29

3a) Chapman-Jouguet Hypothesis (Ref 66, pp 142-43). This subject is also described in our writeup under Detonation, Chapman-Jouguet Postulate, p D231-R

3b) Flow Behind a Chapman- Jouguet Wave (Ref 66, pp 143-44). This subject is also described in our writeup under Detonation, Chapman- Jouguet Wave and Flow Behind It, p D236-L

4) Deflagrations (Ref 66, pp 144-45). This subject is also described in our writeup on p D207ff

III, D. Explicit Solutions of Equations for Chapman - Jouguet Steady Detonations (Ref 66, p 145). Solutions for the Chapman-Jouguet steady detonation wave are obtained from the equations of conservation of mass, the conservation of momentum, the conservation of energy, an equation of state and the C- J condition. Explicit solutions are reported by Eyring et al (Refs 9 & 22a) and by Taylor (Ref 26, pp 87-89)

Detonation Wave, Steady-State, Plane, One-Dimensional .

Definition of a plane detonation wave is given in this writeup under "Detonation Wave, Plane" while the definition of a steady-state detonation wave is given under Detonation Wave, Steady (Steady- State) and Nonsteady (Unsteady). These waves are discussed in Refs 15, 23, 24, 28, 36, 51, 52 & 66

Taylor (Ref 26, pp 65ff), under the heading "Elementary Theory of the Steady Plane Detonation Wave" gives a comprehensive description which we follow here in a slightly abbreviated form

Setting aside for the moment consideration of the mechanism by which stability is realized, Taylor assumes a plane deton wave to have been established in any expl medium. The medium is supposed to be of infinite extent parallel to the plane of the wave, or, alternatively, to be confined in a perfectly rigid tube, so that no lateral motion can occur, and the flow is everywhere *one-dimensional*. Following suggestion of A. Shuster (who proposed in 1893 that there is an analogy between detonation waves and the nonreactive shock waves), the detonation wave is regarded as headed by a shock-front which advances with constant velocity D into the unconsumed explosive, and is followed by a zone of chemical reaction. From the standpoint of an observer accompanying it, the wave will then appear as in Fig 5 from Ref 26, p 65. Undetonated expl flows from the right with constant velocity $u_0 = -D$ into the shock-front X_s . Its pressure, temperature, specific volume, and internal energy per unit mass are p_0, T_0, v_0, e_0 at all points to the right of X_s . At X_s these variables change

abruptly to values p_s, T_s, v_s, e_s , and thereafter continuously as reaction proceeds. However, if the velocity of the shock-front is to remain constant, it is necessary to assume that the wave is steady betw X_s and some later and parallel section X_1 . In other words, conditions to the right of X_1 remain constant in time from the standpoint of a moving observer. Beyond X_1 the wave is not considered to be steady, but is *unsteady*

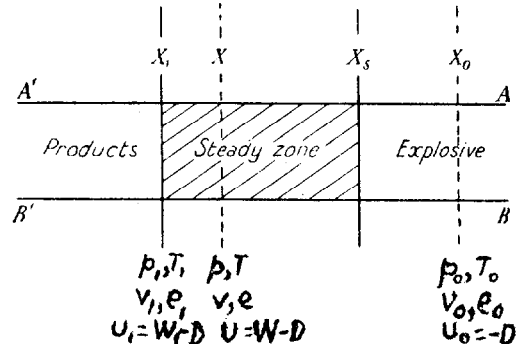

FIG 5 Sectional diagram of the steady detonation wave from the standpoint of an observer accompanying the wave

For the region of the flow bounded by a stream-tube of unit sectional area, and two planes X_0, X , (the former lying in the undetonated expl and the latter within the steady zone), conservation of mass, momentum, and energy within the control surface requires:

$$u/v = u_0/v_0 \tag{VI.1}$$

$$u^2/v + p = u_0^2/v_0 + P_0 \tag{VI.2}$$

$$e + 1/2 u^2 + pv = e_0 + 1/2 u_0^2 + P_0 v_0 \tag{VI.3}$$

Eqs (VI.2 & 3) assume that viscous and thermal transfer across X can be neglected. Such transfer need not be negligible thruout the space betw X_0 and X_1 so that the dissipative processes which must occur at X_s in particular do not invalidate (VI. 2 & 3). It is necessary only that the gradients of temp and velocity should be small at X itself This is probably true thruout the steady zone, except within the shock-front X_s itself, and it will be shown to be undoubtedly true at

X_1 . Eq (VI.1) holds unconditionally, since it expresses only the conservation of mass

In terms p, v as independent variables, eqs (VI. 1, 2 & 3) become:

$$u_0 = -v_0 \sqrt{(p-p_0)/(v_0-v)} \quad (\text{VI.4})$$

$$u = -v \sqrt{(p-p_0)/(v_0-v)} \quad (\text{VI.5})$$

$$e - e_0 = 1/2(p + p_0)(v_0 - v) \quad (\text{VI.6})$$

Eq (VI.6) is invariable

From (VI.4 & 5) we have

$$1/2(u^2 - u_0^2) = 1/2(p - p_0)(v_0 + v) \quad (\text{VI.7})$$

which expresses the change in kinetic energy up to section X

Eq (VI.6), associated with the names of Rankine and Hugoniot, replaces the relation:

$$dE = -p dv \quad (\text{VI.8})$$

which would apply to an isentropic change. Although Hugoniot called eq (VI.6) a "dynamic adiabatic", in the belief that no heat transfer occurred, it is known now that thermal and viscous diffusion play a certain role in the shock-front, and a relation of the form (VI.6) depends in fact on the presence of such dissipative processes. This was shown by Lord Rayleigh in *PrRoySoc* **84A**, 247 (1910)

With reference to a coordinate system at rest in the unconsumed explosive, eqs (VI.4) and (VI.5) become:

$$D = v_0 \sqrt{(p-p_0)/(v_0-v)} \quad (\text{VI.9})$$

$$W = (v_0 - v) \sqrt{(p-p_0)/(v_0-v)}, \quad (\text{VI.10})$$

where W is the *velocity of flow or streaming velocity* in the new reference system, and the positive sense of W is taken in the direction of advance of the wave

From (VI.6) and (VI.10) it is deduced, by eliminating v :

$$DW = (p - p_0) v_0 \quad (\text{VI.11})$$

and by eliminating p :

$$D/W = 1 - v/v_0 \quad (\text{VI.12})$$

Eqs (VI. 6, 9 & 10) apply to any section X within the steady zone $X_S X_1$. The state-variables p, v, e together with the material velocity W , vary from section to section, while D has the same value thruout

Taylor then assumed that reaction, commencing X_S is complete at some section Y (not shown in Fig 5). It is not implied that the chemical composition is constant behind Y, but merely that thermodynamic equilibrium reached at that section is maintained thereafter. However, in the most important field of application of the theory—that of solid and liquid expls — expl evidence suggests that the reaction is frequently (if not always) of a heterogeneous nature, so that the material occupying any section X betw X_S and Y will consist partly of reaction products in relative equilibrium, and partly of unreacted fragments of the original expl. In such a case, Y may be regarded as the section where the last of the expl is consumed (Ref 26pp.65-8)

In further discussion given by Taylor it is shown that for one-dimensional steady plane waves X_1 can coincide with Y, so that the reaction and steady zones also coincide. This does not hold for variable waves or when the motion ceases to be one-dimensional; here X_1 will, in general, lie within $X_S Y$, so that the latter part of the reaction takes place outside of the steady zone. Eqs (VI.6,9 & 10) apply thruout the steady zone and in particular at the section X_1 in which chemical equilibrium is attained. Since D and W_1 appear only in (VI.9&10), they are set aside, leaving (VI.6) which involves $p_1, v_1, & e_1$. If the chem compn were independent of the state variables, e_1 could be defined immediately as a function of p_1, v_1 by means of an appropriate equation of state. As it is, this can still be done, even in the general case where the compn varies, (since the compn is itself expressible), thru the equilibrium conditions, in terms of state variables. Eq (VI.6) therefore defines a relation betw p_1 and v_1 which must be satisfied if the wave is to be steady; but this relation alone is insufficient to determine a unique wave-velocity, such as experiment shows to exist. The selection of a particular end-state (v_1, p_1) characteristic of a stable wave from the manifold presented by eq (VI.6) must depend on considerations other than these implied by conservation laws. These considerations are discussed in Chapter 1, Sect 2 of Taylor's book

If the deton wave is a shock wave initiating chem reaction and continuously supported by energy thus set free, then it must be protected against the *rarefaction* which will always follow. This is impossible, if the velocity of small disturbances behind the wave is greater than that of the wave itself. In other words, if (a_1) is the velocity of sound at X_1 relative to the fluid there, (which itself moves with velocity W_1), and if $a_1 + W_1$ exceeds D , the wave cannot be steady but must lose velocity. If $a_1 + W_1$ is less than D , the wave can apparently remain steady. However, the condition $a + W < D$ must, by reason of continuity, persist some little way into X_1 , X_S , say up to a section X' (not shown in Fig 5). Then the chem energy released within $X' X_1$, can have no influence on what happens ahead of X' and is therefore ineffective from the point of view of supporting the wave front. In practice, this is equivalent to a reduction in the heat of reaction with consequent drop in wave velocity. From such considerations it would appear that the *highest steady-wave velocity will be realized only if the sum of sound and fluid velocities at the end of the steady-zone is equal to the wave-speed itself*. This condition, postulated by D. L. Chapman in 1899 and by E. Jouguet in 1904, is known as the Chapman-Jouguet (C-J) condition. In further discussion, Taylor (pp 69ff), following the approach developed by E. Jouguet in 1917 and by R. Becker in 1922, showed that the C-J condition does hold at one point (p_1, v_1), of all those defined by eq (VI.6) (Ref 26, pp 68-9)

Note: The above discussion on "Steady-State, Plane Detonation Wave" taken from the book of Taylor contains some equations which are listed under DETONATION (AND EXPLOSION) THEORIES and also at the beginning of this Section entitled DETONATION (AND EXPLOSION) WAVES. Although it is realized that these equations are repetitions, they are not eliminated but just referred in order to preserve the cohesion of the description

DETONATION WAVES: STEADY-STATE, THREE-DIMENSIONAL, AXIALLY SYMMETRIC, WITH FINITE REACTION RATE

Evans & Ablow (Ref 66, p 157) in Section V, entitled: "Three Dimensional, Axially Symmetric, Steady-State Detonation Waves With Finite Reaction Rate" stated the following:

The pressures developed in the detonation zone in condensed expls are of the order of 10^3 to 10^5 atm. Material at such pressures cannot in general be contained, so that the flow behind the front has a component radially outward. Gases, which develop much lower deton pressures (of the order of 10 atm), can be confined in a tube, and for them the *one-dimensional approximation* is good. The diverging flow is expected and is found experimentally to result in lower pressures and densities within the *steady wave*, and consequently in lower detonation velocities. Expls which cannot be contained exhibit a diameter effect on deton velocity and on the other deton characteristics, with values tending toward the limit calcd from the *one-dimensional model* as the diam of a cylindrical charge is increased. It is therefore of interest to state the deton equations in a mathematical form in which mass velocity, pressure, and density are dependent on a radial as well as a longitudinal coordinate and to find a relationship betw diam and deton characteristics. In these equations, the superscript \circ will designate deton properties for a *one-dimensional C-J detonation wave*, which is often referred to as an *ideal wave* or as a *plane detonation wave*. The models upon which the *three-dimensional detonation waves* are used embody two arbitrary decisions made to avoid solving a completely stated problem including boundary conditions. The first is the choice of flow pattern between the *shock front* and the C-J or sonic surface. A common assumption is that the flow with respect to the shock front diverges in this region. This assumption is supported by the exptl observation that the *detonation front* is curved, ie, it is oblique to the oncoming flow, and the knowledge that flow crossing such shocks turns toward the shock. The region betw the shock and

the C-J surface is called the *steady zone*, since weak disturbances downstream of the zone cannot propagate into it across the sonic bounding surface. The 2nd decision has to do with the completeness of reaction within the steady zone. In one-dimensional model there is no difficulty in allowing the C-J surface to be at infinity. When the flow diverges, however, the C-J surface is at a finite distance from the shock. It then becomes necessary to decide whether the reaction is completed in the steady-zone, and if not, to determine the consequences of partial reaction outside the steady-state region

In Section V,A (Ref 66, p 157) theories are discussed which assume diverging flow in the steady-state zone, while in Section V,B those that assume parallel flow within the steady zone

V,A. Diverging Flow Within the Steady Zone
 1. *Cylindrically Symmetric Flow in a Detonation Wave*

Wood & Kirkwood (Ref 36a) assumed a curved shock front leading a zone which is cylindrically symmetric. Their coordinates were x , coincident with the axis of the cylindrical charge, and r , the radial distance from the axis. The vector mass velocity \vec{v} has an axial component u and a radial component ω . Fig 30 of Ref 66, p 157 is a sketch of the flow in a coordinate system which moves with the detonation wave. Here ξ = space coordinate within reaction wave; ξ^* = state at C-J surface; U = velocity of wave with respect to observer; $v = u - U$; and r = radial distance from axis

Mathematical treatment of this problem is given in Ref 66, pp 157-59, equations: 5.1.1 to 5.1.27 inclusive

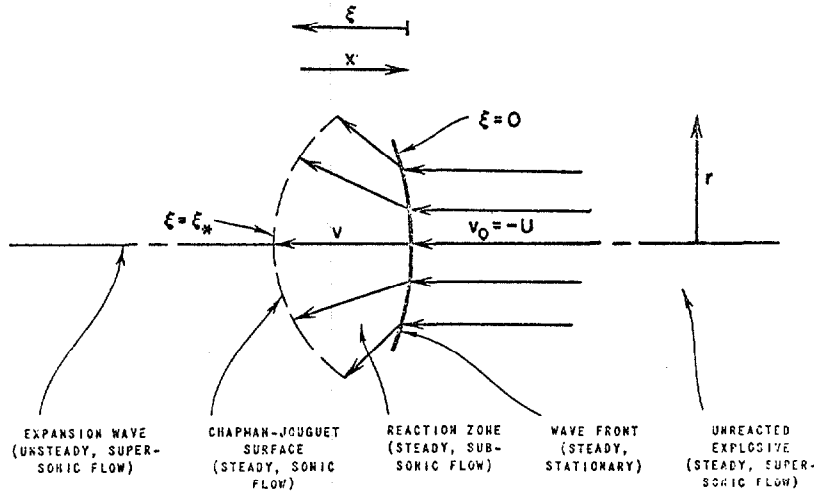

FIG 30 Schematic diagram of cylindrically symmetric flow in a detonation wave, with coordinate system at rest in the detonation front

V,A. Diverging Flow Within the Steady Zone
 2. *Spherically Symmetric Flow in a Detonation Wave*

Eyring et al (Refs 9 & 22a) postulated that the curved shock front is made up of spherical segments and that behind each segment is the radially divergent flow which occurs behind a spherical deton wave initiated at a point inside an explosive (Taylor, Ref

23). The flow lines in a coordinate system at rest in the unreacted expl are shown in Fig 32a. A spherical deton is not steady, since the radius of curvature increases with time. For an instantaneously steady spherical segment of shock front moving in the direction of axis of a cylindrical charge, the flow lines betw the front and the C-J plane in a coordinate system at rest in the shock front will diverge, as shown in Fig 32b

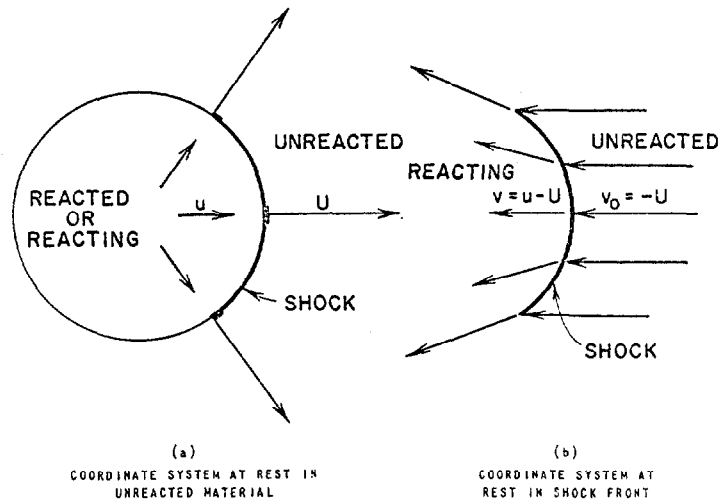

FIG 32 Schematic diagram of spherically symmetric flow in the steady zone of a detonation wave

Eyring et al obtd: (a) relationships allowing them to calculate the deton vel of a solid expl for a given ratio of radius of curvature of a spherical front to reaction zone width, assuming that reaction is complete at the C-J surface; also (b) they extended their calcs for this relationship to waves in which the reaction is not complete in the steady wave, making use of the generalized C-J condition; and finally (c) using the results of (a) and (b) they performed computations which gave for a typical solid expl a relation connecting the deton velocity, the width of the reaction zone, the radius of the chge, and the downstream boundary condition. The results were correlated in empirical equations

Mathematical treatment of the problem is given in Ref 66, pp 160-62, equations 5.2.1 to 5.2.34 inclusive

V.A. Diverging Flow Within the Steady Zone

3. Prandtl-Meyer Flow

It was stated by Evans & Ablow (Ref 66, p 162): "Although, as has been observed in previous sections, the shock is curved when the flow diverges, near the axis it is plane." Jones (our Ref 18a) approximated the divergence of the flow near the axis by that in the Prandtl-Meyer expansion around a corner a distance half a diameter ($d/2$), from the axis. He assumed the Abel equation of state, complete reaction, and the plane form of the C-J condition

Mathematical formulation of Prandtl-Meyer flow is given in Ref 66, pp 162-64, equations 5.3.1 to 5.3.25 inclusive. In Fig 34 is shown the Prandtl-Meyer flow within a steady-deton zone; characteristics are solid lines and stream lines are dashed; line AB is the shock front, r = ratio of radius of axial stream tube to its initial radius and c = sound speed

V.A. Diverging Flow Within the Steady Zone

4. Divergence Due to Boundary Layer

It was stated in Ref 66, p 164 that Fay (our Ref 53a) proposed that the small effect of diam on deton vel which is exhibited by contained gaseous deton can be attributed to divergence of flow betw the shock front and the C-J plane. Since the effect exists even when the tube walls remain intact, the flow divergence cannot be due to imperfect confinement. Fay ascribed it to the effect of a turbulent boundary layer adjacent to the wall of the confining tube. The equations were written in a coördinate system at rest in the wave, so that the tube wall had a vel $v_0 = -U$. A schematic diagram of the flow is shown in Fig 35 from Ref 66. In this coördinate system the wall has a vel higher than the bulk of the gas, and thru boundary layer of thickness $\delta(\xi)$ the vel of the gas decreases continuously from v_0 to $v_e(\xi)$ at $y = \delta$ and is constant at $v_e(\xi)$ for all values of $\delta \leq y \leq d/2$, where $d/2$

is the radius of the tube and y is a coordinate coincident with a radius of the tube and measured from the wall toward the axis. The subscript e denotes values of the flow variables outside the boundary layer. The gas in the boundary layer not only has a vel greater than that of the main stream but is cooler as well because of the conduction of heat to the wall; it therefore has a higher density than the gas in the main stream. The simplifying assumption is made that pressure, which decreases with increasing ξ is independent of y . The fluid

in the boundary layer, because of its higher vel and density, has a larger mass flow per unit area than the rest of the gas stream, and since δ increases with ξ the effect is to cause the flow to diverge. This divergence is expressed in terms of a fictional increase in tube area by increasing the radius an amt $\delta'(\xi)$, such as at given value of ξ shown in equation 5.4.1 of Ref 66, p 164. Further mathematical treatment is given in equations 5.4.3 to 5.4.20 inclusive

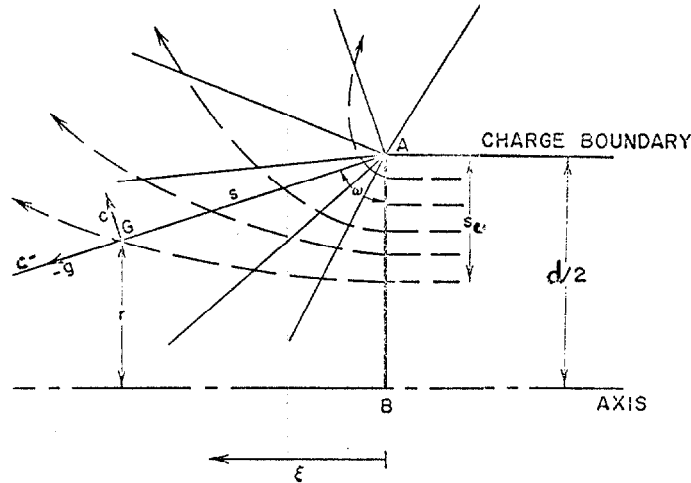

FIG 34 Prandtl-Meyer flow within a steady detonation zone

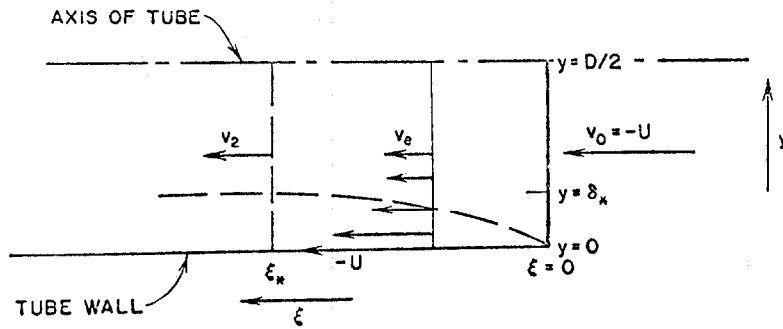

FIG 35 Flow in a steady detonation zone with turbulent boundary layer, with coordinate system at rest in the shock front

Using relaxation distances inferred from the experiments of Kistiakowsky & Kydd (Ref 45) and from his own work, Fay computed ξ_* from eqs 5.4.19 & 5.4.20 (given on p 165 of Ref 66) for several gaseous mixts at 1 atm, initial pressure in tubes 2 cm in diam. The gases were a mixt of 53% acetylene + 47% oxygen and stoichiometric mixts of hydrogen & oxygen, with added helium, argon and ni-

trogen. He then computed δ_* and $(U^0 - U)/U^0$ from eqs 5.4.2 and 5.4.13, respectively. Exptl results indicated a reaction zone thickness varying inversely with initial pressure for hydrogen-oxygen mixtures. This was in agreement with the data for U versus d if Fay's theory is accepted as correct

V.B. Parallel Flow Within the Steady Zone

1. Interposition of Side Rarefaction Wave

Accdg to Ref 66, p 165, Cook (Ref 52, pp 125-28 & 165) and also Hino made the following assumptions:

(a) The flow does not diverge betw the shock front and the C- J plane. Pressure, density, and velocity are constant from the shock front to the C- J plane and the C- J values, as in his one-dimensional model described in Ref 66, p 147;

(b) The C- J position occurs at the intersection with the charge axis of the rarefaction wave moving in from the side so that eq 5.5.1 of Ref 66 will be satisfied and

(c) Any reaction which occurs at $\xi > \xi_*$ does not influence the steady zone

Accdg to these assumptions, the reduction of deton vel with diam is due not to diverging flow but to the circumstance that $\xi_* < \xi_1$

Mathematical treatment is given by equations 5.5.1 to 5.5.14 incl on pp 165-66 of Ref 66

V.B. Parallel Flow Within the Steady Zone

2. Inhibition of Chemical Reaction at Side Boundary

Accdg to Ref 66, p 166, Manson & Guénoche proposed (Ref 46b) that the decrease of deton vel with diam exhibited by gases is due to the inhibition of the chem reaction in the neighborhood of the wall over a layer of thickness δ . Then they made four assumptions (expressed by equations 5.6.1 to 5.6.4 incl of Ref 66) and came to the conclusion that the wave vel at a given diam is determined by the ideal C- J velocity and the failure diameter

V.B. Parallel Flow Within the Steady Zone

3. Stability of Waves in Which Reaction is Not Complete

Accdg to Ref 66, p 166, Schall studied (Ref 34) the stability of steady detonation waves for which reaction is not complete in the steady zone. He assumed that the position of the C- J plane, ξ_* , does not change with velocity of wave U. On the other hand, he assumed that the length, ξ_1 , of the reaction zone varies with U accdg to the eq 5.7.1 listed on p 167 of Ref 66, where also are given eqs 5.7.2 to 5.7.8 incl

Schall's conclusion was that for all values of the parameters of the rate equations there is a narrow stable region near ideal Chapman-Jouguet or complete reaction, $\xi_*/\xi_1 = 1$. For certain values of the parameters there is a second broader stable region extending from $\xi_*/\xi_1 = 0$ to some fraction $\xi_*/\xi_1 > 0$. Schall suggested that the two regions of stability are related to the two steady deton vels, one near the C- J value and the other of low vel of ca 2000 m/sec; such vels are usually observed for liquid and gelatinous expls, as well as for some solid expls. His theoretical results also correspond with the exptl observations that a range of low velocities rather than a single low value can occur (Ref 66, p 167)

The "three dimensional wave system in spinning detonation" was examined by Mac Pherson (Ref 105)

Detonation Wave, Strong and Weak. See Ref 29 & Ref 66, pp 144-45 and also this Volume under Detonation, Strong and Weak p D576

Detonation Wave Structure.

This subject is discussed at the beginning of this section entitled DETONATION (AND EXPLOSION) WAVES and in the following Refs: 27, 40, 51, 65, 103 & 104

Gilkerson & Davidson (Ref 38) studied detonation wave front in gases using the following method: Detonations in a 1-1 mixt of H & O were initiated at 0.035 atm in the presence of 1% iodine by shock waves in a shock tube. Because of ignition delays and the short length of tube available, the detonations did not settle down to a steady state and were of unexpectedly high velocity. The iodine served as a colorimetric indicator for the shock front. The light output of the deton was a step function of time with a front coincident with the shock front within 2-3 microsecs. The reaction zone is thus less than 10^{-4} collisions thick

(See also Detonation Wave Structure Measurements in Condensed Explosives; Detonation Wave Study by a Missile Technique and Detonation Wave Study by Spectrophotometric Analysis)

Detonation Wave Structure Measurements in Condensed Explosives. Measurements of the detonation-wave structure at the axis of long cylindrical charges of NMe and TNT were conducted by Craig (Ref 95a). He determined initial *free-surface velocities* of plates of various thicknesses driven by the explosives. The plates were either of *Dural* (an aluminum alloy contg 4% Cu, 0.5% Mg, 0.25–1.0% Mn and small amounts of Fe & Si), or of *Sierracin* (a thermosetting plastic which is not attacked by NMe as are most plastics). The plate velocities are accdg to Duff & Houston (Ref 38a), related to the pressure in the explosive at a distance back in the explosive approximately proportional to the plate thickness. The free surface velocities were measured using a smear camera technique, described by Davis & Craig (Ref 67a). Here the apparent position of the image of an object reflected in the free surface was recorded as a function of time. The measurements showed that a real detonation wave consists at the charge axis of three zones: (1) a *reaction zone*, (2) an intermediate zone, called the *decay zone*, and (3) a region of relatively slowly decreasing pressure

The reaction zone of NMe is too thin to be observed by the plate-velocity technique, but its presence can be inferred from other experiments. Its length was estimated to be ca 1000 Å from an extrapolation of the unreacted equation of state discussed by Ilyukhin et al (Ref 64b) and the adiabatic thermal explosion theory discussed by Zinn & Mader (Ref 64a). The pressure, P_{c_j} , at the end of reaction zone which corresponds to the head of decay zone, was estimated to be 141 kbar, when free-surface velocity was determined using *Dural* plates and 135 kbar when using *Sierracin* plate

The reaction zone of TNT could be resolved with the plate technique. The pressure at the end of the reaction zone, which is called by Craig "C-J pressure" was found to be not constant (as in the case of NMe), but it changed with the charge size, its diameter, length, boosting, or confinement. For example, the pressure for pressed TNT chge of density 1.63 g/cc at 23° and diam 42 mm was 200 kbar after the run of 8 diameters; corresponding pressure for larger chge (77 mm diam) was

213 kbar. For very large TNT chges pressures as high as 225 kbars were reported. These pressures may be considered as those of the head of decay zone

The decay zone, characterized by a rate of fall in pressure intermediate between those of two zones, is not predicted by any extrapolation of one-dimensional theory. In the liquid explosive NMe, the pressure at the head of the decay zone is essentially independent of the charge size, but the extent of the zone is very strongly dependent on the charge diameter and length. The decay zone increases in length as the detonation runs. In a 38 mm diameter charge, the decay zone is, after a run of 16 diameters, approx 0.6mm long and the pressure falls from 141 to 115 which makes 28 kbar in the zone. For a large diameter NMe chge (such as 76mm) the pressure decrease was from 141 to 127 kbar

In pressed TNT the decay zone behavior is similar to that of NMe, but the pressures at the head and the end of the decay zone are not constant. The pressures at the head of decay zone are the same "C-J pressures" 200 to 225 kbar listed above, while the pressures at the end of decay zone vary between 174 & 193 kbar

Some other expls, such as PETN, CompB plastic-bonded HMX & RDX showed the same kind of behavior as TNT

A phenomenon in gas detonation which is qualitatively similar to the decay zone observed above is described by White (Ref 67b). It was concluded that turbulent flow following the reaction was responsible for the phenomenon in gas. There is no convincing evidence to show that there is or is not turbulence in the flow following the reaction in condensed-phase expls. The decay zone in such expls has been observed only when the deton front has been allowed to become divergent

Detonation Waves, Studying Its Interruption and Reformation by the Shock-Pass-Heat-Filter Method. See Shock-Pass-Heat-Filter (SPHF) Sensitivity Test under Detonation (and Explosion) by Influence or Sympathetic Detonation, p D399

Detonation Wave Study by a Missile Technique was conducted by Ruegg & Dorsey and described in Ref 67. For this study the problems and effects of stabilizing combustion and detonation against hypersonic flow were investigated by observation of a 20-mm spherical missile in a stoichiometric mixt of H and air at rest. Combustion produced detectable effects on the shape and position of the shock wave at Mach Nos betw 4 and 6.5 and at pressures > 0.1 atm. Chem equilibrium probably was not reached in the time the gas spent near the front of the sphere. One of the factors in the delayed equil was delayed ignition behind the shock wave, which was observed betw 1 and 10 microsecs. The ignition delay was explained in terms of chem kinetic theory and was compared with results of experiments in shock tubes. Strong combustion-driven oscillations originated in front of the sphere, with frequencies up to ca 0.1 Mc/sec. These were observed when the Mach No was < 6 and at a pressure of 0.5 atm and at Mach No < 5 and at 1/25 atm. A large reduction of the drag coeff of the missile was noted in one case of intermittent combustion

Detonation Wave Study by Spectrophotometric Analysis. This study was conducted by Richmond and discussed in Refs 68 & 75. For this study mixts of C_6H_6 & O and H & O were detonated in a tube either by a shock wave or by a spark. The arrival of the pressure step was detd by a thin-film, heat-transfer probe with a rise time of 0.5 microsecs. The spectrograph viewed the passing deton wave thru a window slit and lens arrangement. Recording was accomplished by photomultiplier tubes. The deton waves observed consisted of a shock front followed by a combustion front and were classed as "strong", which is equiv to "unsteady" or "decelerating" detonation. Detailed structure of the detonations could not be resolved

Detonation Wave, Temperature Influence on Its Formation. This problem was investigated by P. Laffitte (Ref 1, listed on p D724)

Detonation Wave, Theories of. An elementary theory of the steady plane detonation wave

was described by Taylor (Ref 26, pp 65ff) and in this writeup in abbreviated form under "Detonation Wave, Steady-State Plane, One-Dimensional" and at the beginning of the section entitled "DETONATION (AND EXPLOSION) WAVES". Hydrodynamic and hydrothermodynamic theories are described under "DETONATION (AND EXPLOSION) THEORIES", and in Refs 5, 6, 24, 25 & 62. Detonation wave theories were also described in the following Refs: 10, 43, 51, 52, 59, 60 & 66, listed on p D724ff

Detonation and Shock Waves, Theory of Point Detonation. This subject is described by Baum et al (Ref 59, pp 598-624), under the title "Teoriya Tochechnago Vzryva". See in this Volume under Detonation, Spherical, p D549

Detonation Wave, Three-Dimensional

Under this term are known waves which are generated by condensed expls developing such high pressures (10^3 to 10^5 atm) in the detonation reaction that the flow behind the front has a component radially outward

Evans & Ablow (Ref 66) described three-dimensional waves under the titles: "Three-Dimensional, Axially Symmetric, Steady-State Detonation Waves With Finite Reaction Rate" (pp 157-67), and Three-Dimensional, Transient Detonation Waves" (pp 173-75)

See also this writeup under "DETONATION WAVES: STEADY-STATE, THREE-DIMENSIONAL, AXIALLY SYMMETRIC, WITH FINITE REACTION RATE"

Three-dimensional detonation waves are also described in Refs 31, 51, 59 & 60

Detonation Wave: Transient, One-Dimensional.

In the discussion entitled: One-Dimensional Transient Reaction Waves" by Evans & Ablow (Ref 66, Section VI, pp 167-68), a model is assumed according to which a detonation wave is a shock followed by a deflagration wave. In a steady wave the reaction at a given layer of unreacted material is initiated by the leading shock. It follows that a shock from an external source initiates a detonation wave as was first proposed by Cachia & Whitbread (Ref 51c) and by Majowicz & Jacobs

(Ref 49a). A deton wave in a charge of finite diam can, in general, be initiated by a shock of velocity and pressure less than the leading shock of a steady detonation. The minimum initiating shock for a given chge is experimentally determined by creating shocks of known pressure-time profile within the chge and observing whether the shock develops into a steady detonation wave. There is evidence (accdg to unpublished work of M.W. Evans) that this minimum shock is that which creates in the shocked material a temperature-time history which causes the material to react completely before the temp drops and halts the reaction. This minimum initiating shock, which is a measure of detonation sensitivity, is therefore to be defined in terms of shock strength and duration. Those materials are more sensitive which react faster at shock temps. The sensitivity is dependent not only upon the chemical kinetics but upon the structure of the chge, whether it is a homogeneous solid or liquid, or a mixt of solid grains & air or liquid and air bubbles. A steady deton wave in a typical solid expl in the form of grains mixed with air can be initiated by a pressure pulse with a peak value of the order of 1 to 3 kilobars. The same expl when cast or packed solidly so that little air is present has a pressure sensitivity two orders of magnitude greater. This is because the temp reached in a shocked material depends upon the equation of state, and 2-kbar shock will raise the temp of typical solid only a few degrees. This is not sufficient to allow reaction to approach completion within the usual few microseconds before the reduction of the temp by a rarefaction wave. On the other hand, a 2-kbar shock will raise the temp of the air in a granular chge several hundred degrees. The surfaces of the grains in contact with the air achieve a high temp by heat conduction, a temp which is insufficient, for the applicable reaction kinetics, to permit the material to react completely. The pressure sensitivity of a chge can be predicted, for given grain size and ratio

of solid material to air, by combining calcns of the heat conduction from air to solid grain with the rate of reaction. It was shown in section V of Ref 66 that the pressure of the steady zone of a detonation wave decreases as the chge diam decreases. For every cylindrical chge there is a *failure diameter*, below which the material will not support a steady deton wave. It seems likely that the failure diam is that for which the pressure profile of the steady zone is lower than the pressure sensitivity profile of the material, so that the wave is unable to propagate itself

The theories of *transient processes* leading to steady detonation waves have been concerned on the one hand with the prediction of the shape of pressure waves which will initiate, described in Section VI, A of Ref 66, and on the other hand with the pressure leading to the formation of such an initiating pulse, described in Section VI, B. In Section V it was shown that the time-independent side boundary conditions are important in determining the characteristics of steady, three-dimensional waves. It now becomes necessary to take into consideration time-dependent rear boundary conditions. For one-dimensional waves, the side boundary conditions are not involved

In the same Section VI, Evans & Ablow (Ref 66) described the following subjects:
VI. *A Shock Sensitivity of Homogeneous Solids; Rectangular Pressure Pulse at Solid Boundary*

Ref: H.W. Hubbard & M.H. Johnson, JAppl Phys **30**, 765 (1959) and Ref 66, pp 168-69

VI. B. *Formation of Initiating Shocks in the Interior of the Reactants*

1. *Continually Increasing Pressure at Rear Boundary*

Ref: A. Maček, JChemPhys **31**, 162 (1959) and Ref 66, pp 169-70

2. *Continually Increasing Material Velocity at Rear Boundary*

Ref: U.A. Popov, 7th Symp Combstn (1959) (Pub 1960), pp 799-806 & Ref 66, p 170

3. Successive Formation of Shocks of Increasing Strength

Ref: A.K. Oppenheim, 4th Symp Combustn (1952)(Pub 1953), pp 471-80; Ibid, JAppl Mechanics **20**, 115(1953) and Ref 66, pp 171-73 [See also Detonation Waves; Transients in Propagation of; Transient, Anomalous and Metastable (Unstable) Detonation Waves"; and "Detonation Wave: Transient, Three-Dimensional"]

Detonation Waves: Transients in Propagation of; Transient, Anomalous, and Metastable (Unstable) Detonation Waves. One of the first types of unstable (or metastable) detonation phenomena observed was the low-velocity deton liquid NG, Blasting Gelatin, and Gelatin Dynamites. In these expls low vels are observed in small diam charges by use of cap initiation, and sometimes even under heavy boosting and in large diams, especially in *aged* Gelatin Dynamite (See Detonation; High-Low-, and Intermediate-Order Velocities of and also "Ageing of Dynamites in Vol 1 of Encyl, p A110- R)

The low-velocity propagation in the above expls is called unstable or metastable, because once such velocity is achieved it is unlikely to change to high vel or vice versa. It is distinct from the low-order detonation encountered in some military expls. The latter is not metastable, but purely *transient*; it may result in partial failure or in normal high-order detonation, and is largely unpredictable. Low-metastable velocity of deton is practically unknown in any expls except liquid NG or explosives gelatinized by it, probably because only in the most sensitive types is a low-velocity wave sufficiently intense to support the necessary chemical reaction. It seems very significant therefore that Stresau (Ref 25a) has observed a metastable velocity wave propagation (1200 to 1700 m/sec) in MF compressed at 60000 psi (practically to the crystal density) in a 0.4-cm charge

Transient detonation phenomena are numerous and varied. Jones & Mitchell (Ref 21a) observed such deton in low density

and pressed Tetryl and they showed that the wave that started initially at low vel, suddenly changed after a certain distance from the initiator to the normal high-order deton vel. They showed also that the distance of the low vel regime fell off progressively as the size of the booster was increased.

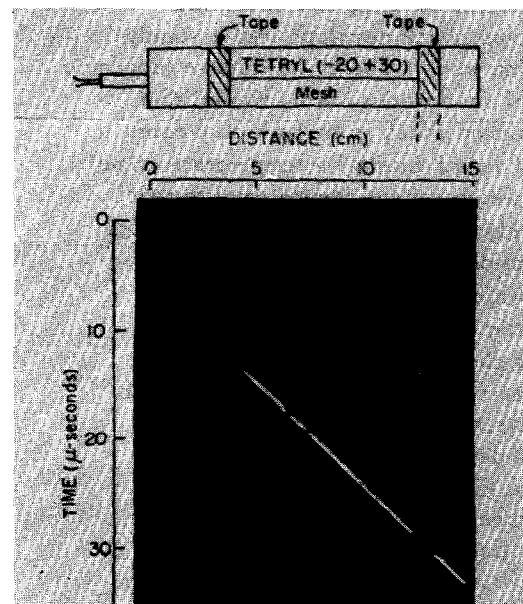

Figure 3.10a

Figure 3.10 Typical dual-velocity traces for cap initiated, loose tetryl and EDNA

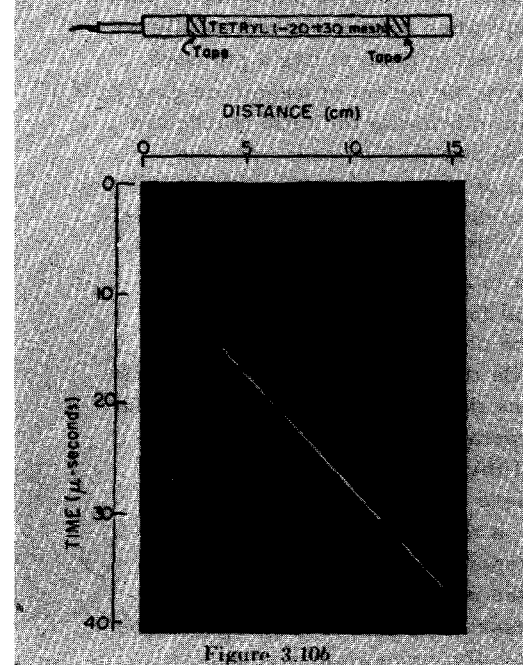

Figure 3.10b

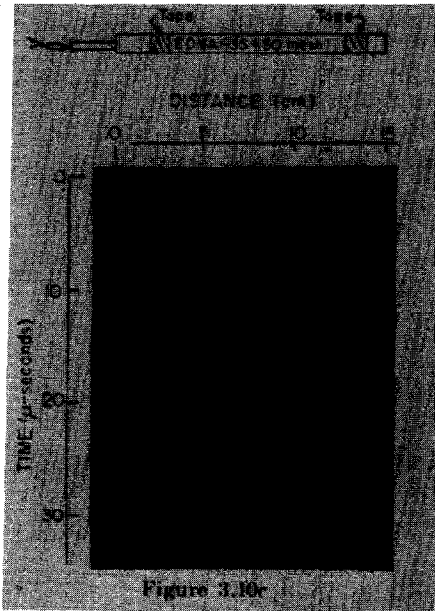

Figure 3.10c

ed and finally the low vel disappeared altogether. Cook et al (Quoted in Ref 52, p 51) have studied this phenomenon in loose, granular Tetryl and EDNA as a function of particle size and diam using only cap initiation. Typical photographic traces with streak camera are shown in Fig 3.10 a,b,c of Ref 52, reproduced here. The distance from the point of initiation to the point of sudden transition to high-order deton appeared quite reproducible and depended on the particle size and diameter, as can be seen in Table 3.3 of Ref 52

TABLE 3.3. DISTANCE OF LOW-VELOCITY REGIME FROM POINT OF INITIATION (#6 CAP) TO STABLE DETONATION

| d(cm) | Tetryl ($\rho_1 = 1.05$) | | EDNA ($\rho_1 = .95$) 35-48 mesh† |
|-------|----------------------------|--------------|--|
| | 20-28 mesh | 35-48 mesh | |
| 0.95 | † | 4.6 cm | 2.5 cm |
| 1.27 | † | 3.0 | 2.3 |
| 1.59 | 4.5 cm | 3.4 | 2.3 |
| 1.90 | 4.4 | 2.1 | 2.1 |
| 2.22 | 4.4 | 1.7 | 2.2 |
| 2.54 | 4.5 | 2.2 | 2.0 |
| 4.39 | 4.3 | 2.2 | No transient |
| 5.04 | 4.0 | No transient | No transient |

† Nonideal velocity merged into transient owing to incomplete reaction.

‡ No transients observable with 65-100 mesh EDNA.

The transient phenomena occurred not only in the nonideal region but extended also well into the ideal detonation region in Tetryl, but disappeared in EDNA when deton became ideal. This can be observed in Fig 3.11 and 3.12 of Ref 52, p 53

Similar but somewhat complicated transient phenomena have been observed by Allen, Cook and Pack (Ref 44b) in fine-grained, loose TNT; mixture of fine and coarse loose TNT; and in cast TNT. Accdg to their data summarized in Table 3.4 (Ref 52, p 54), three separate regimes were evident in the low-density charges of diameters 2.5 to 7.6 cm. In the 1st regime the vel was lowest, (in some cases as low as half of stable vel); in the 2nd regime it was intermediate; and in all but one case it eventually stabilized at the normal vel D_s running from 4200 to 5150m/sec depending on the diam of chge. Conditions were very reproducible except in the 50% fine, 50% coarse TNT mixts. Cast TNT required a much stronger initiator and the observed transient depended critically on the booster. With sufficiently heavy boosting no transient, except possibly a small initial decaying transient from a higher velocity to the normal one was observed (Ref 52, p 53)

Accdg to Cook (Ref 52, p 54), while an intermediate regime has apparently been observed only in TNT, the low-order one with very little chem reaction occurring in it, was observed in other expls, including cast Comp B. For this so-called *threshold boosting* was employed (See in Section 7). The resulting low wave sometimes decayed and disappeared, although at appropriate conditions it could undergo sudden transition to normal high-order deton. T.C. Poulter has made use of this phenomenon to improve the performance of shaped charges (It is not explained by Cook, "how"?)

The irregular curves of Fig 3.14, p 56 of Ref 52, illustrate another type of velocity transient observed in loose, mechanical 80/20-AN/TNT mixts also by Allen, Cook & Pack (Ref 44b). The transient shown in Fig 3.14 appears to be a combination of two types: 1) That encountered in TNT,

EDNA, and Tetryl consisting of velocity discontinuities, and 2) A smooth velocity-distance acceleration usually lasting ca 3 to 4 chge diams and associated directly with nonideal deton. The transient in 50/50-coarse/fine TNT mixt was much like that in the 80/20- AN/TNT mixt, except that transitions were more pronounced and the smoothly accelerating region less pronounced than in the latter case (Ref 52, p 54)

The same investigators studied the mixt of 90/10- AN/RDX. It exhibited a smooth, slowly increasing vel transient from the point of initiation until the final constant vel was reached. There was no tendency for sudden transition as in the case of TNT and the AN/TNT mixt (Ref 52, pp 54-5)

Another transient which, except as masked by other more important transients, probably exists in all ideal expls initiated by *threshold* detonators or boosters was obtd also by Allen, Cook & Pack (Ref 44a) for granular RDX of - 65 + 100 mesh particle size. In 2.5-cm diam chges they observed a transient lasting from 1 to 3 cm and ranging in vel from 5525 m/sec at the beginning to 6180 m/sec at the end of transient. In 4.8-cm diam chges there was observed a transient lasting from 2 to 6 cm with a vel increasing from 5840 to 6235 m/sec. In these experiments a 3/8-inch diam, 1/4-in thick C-4 booster separated from the chge by 0.0005-inch saran sheet was used.

The same investigators obtd a streak-camera trace (See Fig 3.15) from -8+10 mesh TNT shot in 7.6-cm diam chge at $\rho_1 = 1.01$ g/cc, initiated with 114g of loose Tetryl ($\rho_1 = 1.05$) in a 7.61-cm diam by 2.7-cm long chge. The unusual hook at the beginning of the trace is associated with a small radius of curvature of the wave front and initiation on the chge axis. Velocities which follow the hook are shown in Fig 3.15. When a 50/50 cast Pentolite booster 2-in diam and 3-in long was used, no transient vel was observed, probably because the

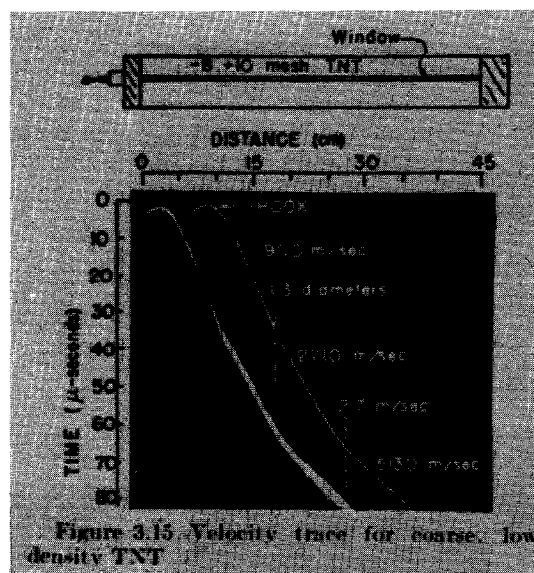

Figure 3.15 Velocity trace for coarse, low-density TNT

normal transient was eliminated by over-boosting (Ref 52, p 56)

Another type of transient detonation phenomena occurs in relatively insensitive expls detonating at a velocity below sound velocity of the charge itself. In the Tritonal example the 5-cm-diam chge was photographed at $2.08 \mu\text{sec}/\text{frame}$ in its own light using a pressed Tetryl booster, 5-cm diam by 2.5-cm length. It propagated ca $10 \mu\text{sec}$ at low velocity and then suddenly developed high-order deton ca one chge diam ahead of the low-velocity wave. The high-order deton then propagated both forward and backward, the reverse wave colliding on frame 10 with the low-order wave, the collision region being evident on all later traces. This type of detonation, called *jumping* by Cook, is shown in Fig 3.17a, p 58

Another transient "jumping" deton phenomenon is described by Cook for classified expls called "Explosive δ " on p 57 and "Explosive β " on p 59. We are not including the description of these transients (Figs 3.17b and 3.18a) since their compns are not known

In Fig 3.18b (not reproduced here) the 94/6-AN/Fuel Oil mixture may be seen to propagate the entire length (90cm) in a quasi-steady, but actually pulsating manner. The av vel was 2540 m/sec, and the trace superficially straight. However, careful

examination showed the velocity to follow ca a sine wave form in which it fluctuated nearly sinusoidally ca 30% from the mean, with a wave length of ca 45 cm. It is possible that the (apparent) pulsation in velocity may really have been merely the wave rotating around the axis of the chge. Further investigation is required (Ref 52, pp 57-8)

The conditions responsible for the jumping detonation are evidently those for propagation of deton thru inert media such as glass and steel in which the shock wave first outruns the reaction and is then suddenly overtaken after the chemical reaction has finally built to a critical stage in which a *heat pulse* is able to propagate (Ref 52, p 59)

Under the title "Recapitulation of Observed Transient Phenomena", Cook summarizes on p 59 the following types of metastable and transient wave propagations observed before 1958:

- 1) Low-order (metastable) deton observed in NG and Gelatin Dynamites
- 2) Constant low-order wave propagation suddenly undergoing a sharp or discontinuous transition to normal, high-order deton, as observed in Tetryl and EDNA (definite transition distance) and sometimes in NG and Gelatin Dynamites (irregular transition distance)
- 3) Successive sharp transitions from low- or constant- (or nearly constant) velocity regimes to regimes of higher- constant or nearly constant) velocity propagation. Observations of this type have so far been limited to TNT
- 4) Smoothly accelerated velocity transient which finally stabilizes at $L/d = 3 \pm 1.0$ (where L is length and d is diam of chge). This type is associated with nonideal deton in *point-initiated charges*. It is illustrated by 90/10-AN/RDX
- 5) Combination of type 2 or 3 and type 4. This transient has been observed in 50/50- coarse/fine TNT and in 80/20-AN/TNT, the former with type 2 or 3 predominating and the latter with type 4 predominating
- 6) Smoothly accelerating velocity transient stabilizing in less than three charge-diameters.

This type is associated with point initiation in ideal expls. It is illustrated by fine, granular RDX

7) Decaying velocity sometimes resulting eventually in failure. This occurs in expls strongly boosted below the critical diam, or similarly by *overboosting* of a low-velocity expl

8) The *jumping* detonation

In addn to the above described transient wave propagations there are so-called *anomalous wave propagations*. The most important of these is illustrated by the

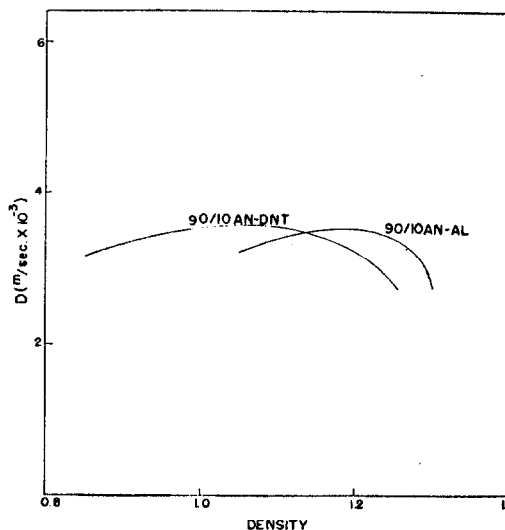

Figure 3.6 Typical velocity-density curves for AN-combustible mixtures in small diameter (-65 + 100 mesh AN; $d = 10$ cm)

anomalous $D(\rho_1)$ curves, such as in Fig 3.6 of Cook's p 49, which is characteristic of nonideal, coarse high-AN expls, sensitized with nonexplosive fuels (such as oil, liquid DNT powdered Al, wax, etc) or with small percentages of expls such as TNT or even NG. These conditions are of particular importance in commercial expls, as they are involved in nearly all expls with high percentage of AN. In the nonideal expls with relatively large percentages of expls other than AN (such as TNT, PETN, RDX, etc) the surface burning (two-thirds-order) (See Ref 52, p 127) rate law was found to apply quite generally. These mixts are of a type in which the amt of heat generated by

the reaction of at least one of the ingredients alone without mixing with those of any of the other components would raise the temp in the products to or above the final equilibrium temp T_2 . In an AN-fuel mixt, on the other hand, the temp attained by reaction of AN alone cannot exceed ca 1720°K, whereas that for complete mixt goes much higher. Hence, mass transfer and possibly heat transfer are much more important in these mixts (Ref 52, p 140)

The fact that the rate of propagation of AN expls decreases rapidly with density above the density corresponding to the maximum of the $D(\rho_1)$ curve of the Fig 3.6 indicates that the limiting factor is the mass transfer; diffusion falls rapidly with increasing density or pressure in the vapor phase, but thermal conductivity does not. This situation corresponds approximately to that occurring in granular low expls such as BkPdr, in which the burning rate decreases with increasing density (Ref 52, p 141)

Accdg to Cook, while it has been shown that the Eyring surface-erosion model does not apply, the geometrical model does apply in the case of expls with anomalous $D(\rho_1)$ behavior (Ref 52, p 141)

Expls with anomalous behavior are suitable to control the effective pressure time ($p-t$) curve of blasting expls, such as for their *heaving action*. In some types of blasting operations, for example, one desires a low rate-of-pressure development, but a sustained pressure, eg, in coal mining, trap rock and monumental stone quarrying, etc. This is achieved by the use of expls contg coarse AN, SN, and fuels, together with a minimum of NG. In coal mining, permissibles of vastly different heaving action may be obtd with a single expl compn but with ingredients of different particle size. For example in three expl compns consisting of AN 80, NG 7 & standard dopes 13%, AN in Dynamite A is of 150 mesh, in Dynamite B -65 mesh and in C -20 mesh. When shot in $p-t$ cannon A will develop a high peak (blasting) pressure similar to that for fine PETN (as shown in Fig 6.10, p 135 of Ref 52), followed by rapid decay, B has an intermediate blasting action, while C develops

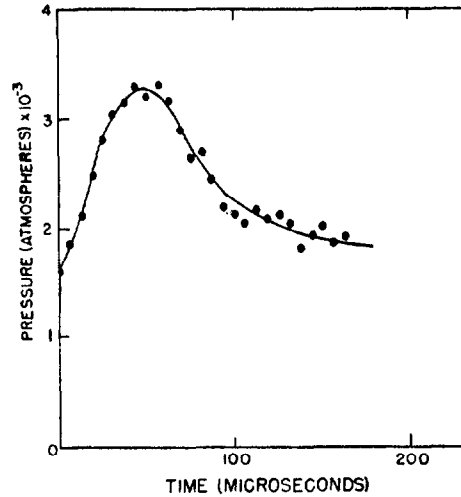

Figure 6.10. Cannon pressure-time curve for fine PETN (25-g charge)

a low but sustained pressure and a superior heaving action of long duration. The application of the geometrical model to the observed velocity-diameter curves of expls resembling very closely these expls, gave reaction time τ_2 of 80 μ sec for A, 190 μ sec for B and 460 μ sec for C. The τ_3 values were ca 5 times longer

Note: Subscript 2 indicates the conditions at C-J plane, while subscript 3 indicates the expl state corresponding to products of deton in *static equilibrium* within the volume of original expl (Ref 52, p 376)

Now in blasting with these expls a normal burden begins to move appreciably only ca 400 to 600 μ sec after deton and does not acquire its maximum vel until more than a millisecond later. Hence, one requires reaction times longer than 400-600 μ sec before it will be possible to observe the differences in blasting action betw the above three expls. Since great differences are actually observed and well recognized in commercial blasting, it must be concluded that the reaction times of the expl with the longest reaction time must be of the order of milliseconds (and not microseconds). The differences are easily seen even between A & B. This is in agreement with Cook's geometrical model but not with the Jones' nozzle theory or Eyring's curved-front theory, since in the latter theories

even C (which has one of the longest reaction times of any of the commercial Dynamites), would have τ_2 of less than 50msec (curved-front theory) or less than 150msec (nozzle theory). It seems clear, therefore, that the reaction times of the geometrical model correctly apply to these and similar commercial expls. Moreover, it seems justifiable to conclude that the p-t curves measured by the cannon method provide a direct experimental measure of the *heaving action* of such expls (Ref 52, pp 141-42)

Detonation Waves, Transient, Three-Dimensional.

Accdg to Evans & Ablow (Ref 66, Section VII, p 173), two aspects of three dimensional transient detonation waves have received attention: (1) the initiation of detonation by a point or localized source; (2) oscillating detonation.

VII, A. *Initiation of Detonation at a Point*
Ref: G.I. Taylor, PrRoySoc **200A**, 235-47 (1950) & Ref 66, pp 173-74

The question considered is a description of the conditions which must be met by a localized initiator if a spherical detonation wave is to be formed. The first problem is a determination of the possibility of the existence of such a wave. Taylor analyzed the dynamics of spherical deton from a point, assuming a wave of zero-reaction zone thickness at which the Chapman-Jouguet condition applies. He inquired into the hydrodynamic conditions which permit the existence of a flow for which $u_2 + c_2 = U$ at a sphere which expands with radial velocity U (Here U = vel of wave with respect to observer; u_2 = material velocity in X direction; and c = sound vel; subscript 2 signifies state where fraction of reaction completed $\epsilon = 1$). Taylor demonstrated theoretically the existence of a spherical deton wave with constant U and pressure p_2 equal to the values for the plane wave, but with radial distribution of material velocity and pressure behind the wave different from plane wave

Following this discussion is the mathematical treatment (which includes equations 7.1.1 to 7.1.4 incl), demonstrating that three-

dimensional, transient detonation waves exist (pp 173-74)

On p 174 are examined requirements upon the initiator for such waves. An initiating shock must be of sufficient pressure and duration to permit complete reaction before a terminating rarefaction wave intervenes. The quantitative requirements as in the one-dimensional case, are determined by the reaction kinetics, the physical state, and the equations of state of the material or of its components if the chge is heterogeneous. The shock-terminating rarefaction is here provided by the three-dimensional geometry and does not need a pressure-relieving rear boundary condition as in the one-dimensional case. If the shock wave is inadequate for detonation initiation, a deflagration frequently occurs instead. In Section VI, B of Ref 66, it was shown that for the correct boundary conditions a deflgm can create a shock wave which can initiate a deton

VII, B. *Detonation Waves with Fluctuating Velocity*

Many expls and detonable gases of near stoichiometric compn have a constant deton vel after the wave has progressed some distance from the initiator. There are, however, detonable materials which support a deton wave of *fluctuating velocity*, usually an oscillation about an average vel. Such behavior is observed in granular expls which characteristically have low values of U/U^0 and thus are assumed to have a long reaction zone (Here U = velocity of wave with respect to observer and the superscript 0 indicates that fraction of the reaction completed ϵ is equal to 0). Examples are mixts of K perchlorate, Amm perchlorate, Amm nitrate with small amts of Al (or other combustible metal), PETN (or other HE) (Evans, unpublished work). A fluctuating velocity was also observed in gases where the phenomenon is usually referred to as *spinning detonation*. The gases which support such fluctuating waves have compositions near the deton limits; this suggests that their reaction rates are probably slow and the reaction zones long

The experimental observations for gases have been summarized by Fay (Ref b), who also investigated longitudinal oscillations.

Manson (Ref a) showed that transverse acoustic oscillations of the burned gas of the lowest permitted frequencies with none or one or two (fixed) nodal meridional planes agreed reasonably well with the observed frequencies. Chu (Ref c) attempted, but did not succeed, to solve the problem of the origin of oscillations. Shchelkin (Ref d) postulated that instability of a deton wave occurs if the induction time is doubled by the drop in temperature of unburned gas. An alternative theory of *spinning detonation* has been proposed by Predvoditelev (Ref e), according to which *helical flow* is assumed to occur in the tube. By helical flow P means a central core rotating almost like a rigid body as it moves axially forward, the core being surrounded by a turbulent transition to zero flow velocity at the wall. He described spinning deton in terms of the rotation of a nearly plane surface tilted to the axis and rotating about it. Such a flow is not possible however, (Ref 66, p 176), because angular momentum is not conserved. The incoming uniform flow has zero angular momentum, while Predvoditelev's outgoing flow has zero angular momentum, though only opposing torques are applied

Refs: a) N. Manson, CR **222**, 46 (1946) and ONERA, Institute Français du Petrole (1947); Engl transl ASTIA **AD-132808**
 b) J.A. Fay, J Chem Phys **20**, 942 (1952)
 c) B.T. Chu, Proc Gas Dynamics Symp on Aerothermochemistry, Northwestern Univ, Aug 22-24 (1955), pp 95-111
 d) K.I. Shchelkin, ZhEksp i TeoretFiz **36**, 600 (1959); Soviet Phys JETP **9**, 416 (1959);
 e) A.S. Predvoditelev, 7th SympCombstn (1959) (Pub 1960), pp 760-65
 f) Our Ref 66

Detonation Wave, Two-Dimensional. Under this term is known a wave generated by the lateral dispersion of a detonating substance, in other words, the two-dimensional motion of the detonation products. Two-dimensional deton waves may be either stationary or unsteady. Various numerical methods have been applied to the solution of a stationary wave and of the distribution of the fluid properties behind a steadily expanding cylindrical detonation wave as described in Refs 56a, 60, 63a, 74, 93a & 93b

Detonation Waves, Undercompressed. See under Detonation Waves, Overcompressed and Undercompressed

Detonation Wave, Unstable. See under "Detonation Waves: Transients in Propagation of; Transient, Anomalous and Metastable" (Unstable)

Detonation Wave, Vibratory. See Ref 81

Refs (for Detonation Waves); 1) P. Laffitte, CR **186**, 951 (1928) (L'influence de la température sur la formation de l'onde explosive)
 1a) B. Lewis & J.B. Friauf, JACS **52**, 3905 (1930) (One-dimensional approximation)
 2) Wm. Payman et al, PrRoySoc **132A**, 200-13 (1931); **148A**, 604-22 (1935); **158A**, 348-67 (1937) and **163A**, 575-92 (1937) (Explosion waves and shock waves)
 3) C. Campbell et al, PrRoySoc **137A**, 380 (1932) (Measurement of pressure developed in explosion waves)
 3a) H. Langweiler, ZTechnPhysik **19**, 271 (1938) (Langweiler wave) (Engl transl NACA TechMem (1950)
 4) Ya.B. Zel'dovich, ZhEksp i TeoretFiz **10**, 542 (1940) (On the theory of propagation of detonation in gaseous mixtures)
 4a) L.R. Carl, "The Breaking Theory of Detonation", J FranklInst **230**, 207-27 & 325-74 (1940)
 5) G.B. Kistiakowsky & E.B. Wilson, Jr. "Final Report on the Hydrodynamic Theory of Detonation and Shock Waves" OSRD **114** (1941)
 6) J. von Neumann "Theory of Detonation Waves. Application of Chapman-Jouguet Theory, OSRD **549** (1942) and OSRD **1140** (1942)
 7) Ya. B. Zel'dovich, ZhEksp i Teoret Fiz **12** 389 (1942) (Pressure and velocity distribution in detonation products of an explosion specifically for spherical propagation of detonation wave)
 7a) S.R. Brinkley, Jr & E.B. Wilson, Jr, "Determination of Pressure of Several Explosives, OSRD **1231** (1943); PB-18859
 8) W. Döring, AnnPhysik **43**, 421 (1943) (Deton wave and his theory, developed independently from Zel'dovich and von Neumann)
 8a) S.R. Brinkley & E.B. Wilson, Jr, OSRD Rept **1231** (1943) (PB-18859)
 9) H. Eyring et al, The Chemical Reaction in a Detonation Wave", OSRD Rept **3796** (1944), ATI 31086
 10) Ya.B. Zel'dovich, "Teoriya Goreniya i Detonatsii Gazov"

- (Theory of Combustion and Detonation of Gases), TipogrAkadNauk, Moscow (1944)
- 11) A. Grib, *Prikladnaya Matematika i Mekhanika* **8**, 169 (1944) (On the propagation of a plane wave for an ordinary explosion near a plane wall) 12) S.J. Jacobs & R.S. Grabenstetter, "Shaped Detonation Waves," OSRD **5603** (1946) 12a) K.O. Friedrichs, NAVORD Rept **79-46** (1946) (Quoted from Ref 66, pp 153 & 176) 13) G.N. Abramovich & L.A. Vulis, *DoklAkadN***55**, 111 (1947) (On the mechanics of propagation of detonation and combustion) 14) K.P. Stanyukovich, *Ibid* **55**, 315 (1947) (Flow of detonation products in the case of oblique deton waves) 15) Ya. B. Zel'dovich & K.P. Stanyukovich, *Ibid* **55**, 591 (1947) (On the reflection of a plane deton wave) 16) B.V. Aivazov & Ya.B. Zel'dovich, *ZhEksp i TeoretFiz* **17**, 889 (1947) (Formation of an over-compressed wave in a constricted pipe) 17) W. Weibull, *Nature* **159**, 402 (1947) (Spread around the initiating point of the detonating wave in High Explosives) 18) W.C.F. Shepherd, *Nature* **160**, 92-3 (1947) (Spread around the initiation point of the detonation wave in HE's (Discussion on *predetonation period* in powdered Tetryl of 1.10 g/cc density) 18a) H. Jones, *PrRoySoc* **189A**, 415 (1947) (See in the text under "Radius of the Curvature of the Detonation Wave Front" and also under Prandtl-Meyer Flow) 19) Muraour (1947) (Booklet), pp 44-8 (Detonation and shock waves) 20) E. Dubois, *MAF* **21**, 369-93 (1947) (Investigation by means of a piezoelectric apparatus the forces of instantaneous pressures produced when explosion waves meet an obstacle) 20a) R.H. Cole, "Underwater Explosions", Princeton UnivPress, Princeton, NJ (1948), Chapter 3 21) P. Caldirola, *JChemPhys* **16**, 846-47 (1948) (Detonation wave in nuclear explosions) 21a) A. Jones & D. Mitchell, *Nature* **161**, 98 (1948) (Quoted in Ref 52, pp 51 & 60) 22) W.B. Cybulsky et al, *PrRoySoc* **197A**, 51-72 (1949) (Explosion waves and shock waves) 22a) H. Eyring et al, *Chem Revs* **45**, 69 (1949) (See in the text under "Radius of the Curvature of the Detonation Wave Front" 23) G.I. Taylor, *PrRoySoc* **200A**, 235-47 (1949) & *CA* **45**, 10585 (1951) (Dynamics of combustion products behind plane and spherical detonation wave fronts in explosives) 24) G.B. Kistiakowsky, "Theory of Stationary Detonation Waves", pp 952-55 and "Calculation of Detonation Parameters, pp 955-59 in Kirk & Othmer **5** (1950) (Not found in 2nd edition of Kirk & Othmer) 24a) W.G. Penney and collaborators, "Discussion on Detonation", *PrRoySoc* **204A**, 1-33 (1950) 25) S. Travers, *MAF* **24**, 443-50 (1950) & *CA* **45**, 8772 (1951) (Present state and value of hydrothermodynamic theory of explosions and shocks) 25a) R.H. Stresau NAVORD Report **2460** (May 1952) (Quoted in Ref 52, pp 51 & 60) 26) Taylor (1952), pp 4-9 (The propagation of the detonation wave); 65-9 (Elementary theory of the steady plane deton wave); 74 (Döring's treatment of the Chapman-Jouguet condition) 27) C.M. Mason, "The Physics and Chemistry of the Explosives Phenomena", *USBurMines ProgrRept* Jan-March 1952, p 6 (Theory of the structure and stability of detonation waves) 27a) J.O. Hirschfelder, et al, "The Theory of Flames and Detonations", *4thSympCombstn* (1953), p 190-211 28) S.R. Brinkley, Jr & J.M. Richardson, "Plane-Detonation Waves with Finite Reaction Velocity", *4th SympCombstn* (1953), pp 450-57 28a) L. Deffet, et al, *4th SympCombstn* (1953), pp 481-85 29) A.R. Ubbelohde, "Possibility of Weak Detonation Waves". *Ibid*, pp 464-67 30) Anon, "Ordnance Explosive Train Designers' Handbook", *NOLR* **1111** (1952), page 7-15 (Detonation Waves); p 7-16 (Overboosting) 31) C.G. Dunkle, "The Detonation Wave in Three Dimensions", Lecture delivered at Picatinny Arsenal, Dover, NJ on 17 April, 1953 32) T. Sakurai, *JIndExplsSoc Japan* **14**, 220-25 (1953) & *CA* **49**, 11284 (1955) (Experimental determination of pressure in detonation wave) 33) H. Fukuda & S. Maruyama, *Ibid* **15**, 264-69 (1954) & *CA* **49**, 11285-86 (1955) (Detonation wave propagation in cartridges of small diameter) 33a) N. Manson, "Formation and Velocity of Spherical

- Explosion Waves in Gaseous Mixtures", *Revue I.F.P.*, **IX**, No 4, April 1954
- 33b) H.M. Pike & R.E. Weir, "The Passage of Detonation Wave Across the Interface between Two Explosives", British Theoretical Research Report **No 7/50**. Armament Research Establishment Rept **No 22/50** (1954) (Conf) (Not used)
- 34) R. Schall, *Z AngewPhys* **6**, 479 (1954); *Ibid*, CR CongrInternChimInd 27^e Congr, Bruxelles, 1954 (Quoted from Ref 66, p 166)
- 35) G. van Roy, et al, *Explosifs (Liege)* **7**, 21-6 (1954) (Study of detonation waves by the method of X-ray sparks) 35a) J.O. Hirschfelder et al, "Molecular Theory of Gases and Liquids," Wiley, NY (1954)
- 36) J.G. Kirkwood & W.W. Wood, *JChemPhys* **22**, 1915-19 (1954) & *CA* **49**, 2073 (1955) (Structure of a steady-state plane detonation wave with finite reaction rate) 36a) W.W. Wood & J.G. Kirkwood, *JChemPhys* **22**, 1920-24 (1954) & *CA* **49**, 2073 (1954) (Relation between velocity and radius of curvature of the deton wave) 36b) Anon, "Military Explosives", **TM 9-1910** (1955) pp 37-9 (Detonation wave) [Superseded by TM 9-1300-214/TO 11A-1-34 (1967) listed here as Ref 98] 37) P. Lieber & A. Farmer, "Studies of Wave Propagation in Granular Media", RPI (Rensselaer Polytechnic Inst, Troy, NY), Report **00R**, Contract No DA-30-115-ORD-459 (1955) 37a) S. Paterson, 5th SympCombstn (1955) (Quoted from Ref 66 pp 149 & 177) 38) W.R. Gilkerson & N. Davidson, *JChem Phys* **23**, 687-92 (1955) & *CA* **49**, 10625 (1955) (Structure of detonation wave front of gases was studied by method of shock tube) (See its abstract under Detonation Wave Structure) 38a) R.E. Duff & E. Houston, 2nd ONRSympDeton (1955), p 225 (See under Detonation Wave Structure Measurements in Condensed Explosives) 39) S. Minshall, *JApplPhys* **26**, 463-69 (1955) (Properties of elastic and plastic waves determined by pin contactors and crystals) 40) C.G. Dunkle, "Introduction to Theory of Detonation of Explosives," Syllabus of 21 Nov 1955 and Lecture Delivered at Picatinny Arsenal on 13 Dec, 1955 (Structure of the deton wave)
- 41) Ya. B. Zel'dovich & A.S. Kompaneets, *Teoria Detonatsii*, GosTekhIzdat, Moscow (1955). Engl transl published in 1960 is listed here as Ref 60
- 42) G.H. Duffey, *JChemPhys* **23**, 401 (1955) & *CA* **49**, 5934 (1955) (Detonation waves and the principle of minimum entropy products)
- 43) K.P. Stanukovich, "Teoriya Detonatsionnykh Voln; Neustanovivshiesya Dvizheniya Sploshnoi Sredy "(Theory of Detonation Waves. The Unsteady Motions of a Continuous Medium), GosIzdatTekhn-Teor Liter, Moscow (1955), Chapter 7, pp 309-63. Engl transl entitled K.P. Stanyukovich, "The Theory of Detonation Waves," Technical Information and Library Services Translation **TIL/T.4896a**. Ministry of Aviation, GtBritain (Feb 1960) 43 a) M.A. Cook et al, *TrFaradSoc* **52**, 369 (1956) (Quoted from Ref 52, pp 83 & 89) 44) M.A. Cook et al, Measurements of Ionization and Electron Densities in the Detonation Waves in Solid Explosives," ERG (Explosives Research Group). Univ of Utah, TechRept No 1, Contract AF-18 (603)-100 (1956) 44a) M.A. Cook et al, *JApplPhys* **27**, 269-77 (1956) (Deton wave fronts in ideal and nonideal expls) 44b) H.J. Allen, M.A. Cook & D.H. Pack, "Transients in Detonation," ERG, Univ of Utah, Tech Rept No **50**, Contract N7-onr-45107, Proj No 357 (1956) 45) G.B. Kistiakowsky & P.H. Kydd "The Measurement of Density Charges in Gaseous Detonations", 2nd ONRSympDeton (1955) and *JChemPhys* **25**, 824 (1956) 45a) W.W. Wood & J.G. Kirkwood, *JChem Phys* **25**, 1276 (1956) (Quoted from Ref 66, pp154 & 178) 46) H. Ahrens, *Explosivstoffe* **4**, 102-09 (1956) (The significance of the selective behavior of the deton wave in the field of permissible expls) 46a) T.E. Holland et al, *JApplPhys* **28**, 1217 (1957) (Phenomena associated with large crystals) 46b) N. Manson & H. Gueneche, 6th SympCombstn (1957) (Quoted from Ref 66, p 166) 47) L. Deffet & J. Boucart, "The Effect of Slight Confinement on the Detonation Waves in Solid Explosives", 6th SympCombstn (1957), 642-48 48) R.B. Clay, M.A. Cook et al, "Plate Velocities in Impulse Loading by Detonation Wave," Paper presented at Symposium on Shock Waves in Process Equipment, Annual Meeting AmerInst ChemEngrs, Chicago, Ill (1957) 49) M. Sultanoff "Explosive Wave Shaping by Delayed Detonation," *BRL* **1022** (1957) 49a) J.M. Majowicz & S.J. Jacobs, "Tenth Annual Meeting of

- Division of Fluid Dynamics of AmPhysSoc," Nov 1957 (Quoted from Ref 66, p 167)
- 50) D.H. Edwards & G.T. Williams, *Nature* **180**, 1117 (1957) (Effect of tube diameter on the pressures in gaseous detonation waves)
- 51) Dunkle's Syllabus (1957-1958); Session 2, p 2 (Definition of detonation wave); Session 14, *Structure of the Detonation Wave*, which includes: Distinction Between Shock and Detonation Fronts (pp 163-66); Application to Solid Explosives (166-68); One-dimensional Steady-state Process (168-69). Session 17, *Detonation in Solid Explosives* which includes: Definition of Detonation Wave (p 193); Progress of the Detonation Wave (196-98); Transmission of Energy (198-200); and Dark Waves (p 202). Nonsteady and Steady Detonation Waves (258-64). Detonation Head Model (285-90) 51a) K. Hino, *IndExplsSoc, Japan* **19**, 169 (1958) (Quoted from Ref 66, pp 165 & 177) 51b) J.O. Hirschfelder & C.F. Curtiss, *JChemPhys* **28**, 1130 (1958) (Quoted from Ref 66, pp 153 & 1.77) 51c) G.P. Cachia & E.G. Whitbread, *PrRoySoc* **246A**, 268 (1958), (Quoted from Ref 66, p 167) 52) Cook (1958), Chapter 3 *Velocity of Propagation of Ideal and Nonideal Detonation Waves*, which includes: Ideal Detonation (pp 44-8); Nonideal Detonation (48-50); Transient, Metastable and Unstable Detonation Waves (50-57); Jumping and Decaying Detonation (57-9); and Recapitulation of Observed Transient Phenomena (59-60). Chapter 5, *Detonation Wave Shape and Density Properties*, which includes: Theoretical Wave Profiles (91-3); Langweiler Wave (91); Experimental Detonation Head in Gases (93-7); Experimental Detonation Head in Condensed Explosives (97-9); Wave Front (99-106); Blast Contours (106-11); Free Surface Velocity (111-16); Billiard-Ball Mechanism of $V_f(t)$ (116-20); and Detonation-Head Model (120-22). Transient and Anomalous Wave Propagation (140-41). Commercial Application of Nonideal Detonation (141-42) Note: End effect is defined by Cook as "the impulse loading of a target at the end of a cylindrical charge" 53) S. Basu & J.A. Fay, "Ionization in Detonation Waves," 7th Symp Combstn (1959), 277-86 53a) J.A. Fay *Phys Fluids* **2**, 283 (1959) (Quoted from Ref 66, p 164) 54) J.A. Nicholls et al "Studies in Stabilized Gaseous Detonation Waves," 7th SympCombstn (1959), 662-72 55) Ya. K. Troshin, "The Generalized Hugoniot Adiabatic Curve," *Ibid*, p 789 (Overcompressed detonation waves) 56) F.J. Martin & D.R. White; "Formation and Structure of Gaseous Detonation Waves," *Ibid*, 856-65 56a) F.H. Harlow "Two-Dimensional Hydrodynamic Calculations", *LARept* **2301** (1959) 57) A.Ya. Apin & L.G. Bolkhovitinov, *Dokl-AkadN* **124**, 338-39 (1959) & *CA* **55**, 6865 (1961) (Measurement of the rate of combstn of smokeless proplnt grains directly in detonation wave by using the ionizing probe method. The combstn rate was directly proportional to pressure and at 60000kg/sq cm, the rate for NB proplnt was 200-300m/sec) 58) A.N. Dremine & P.F. Pokhil, *DokAkadN (PhysChem Section)* **128**, 839-41 and 989-91 (1959) (Detonation wave parameters of TNT, RDX, NG and Nitromethane) 59) Baum, Stanyukovich & Shekhter (1959), 225-71 (Theory of detonation wave); 598-624 (Theory of "point" explosion); 624-40 (Spherical explosion) 60) Zel'dovich & Kompaneets (1960) (Engl transl of Ref 41); 68-85 (Detonation waves); 85-95 (Flow of chem reaction in the detonation wave); 97 (Formation of overcompressed deton wave by forcing the deton of gaseous mixture to pass from a wide pipe to a narrow one); 97-104 (Discussion on overcompressed and undercompressed deton waves); 247-61 (Discussion on some problems on the motion of deton products of condensed expls following the deton wave); 261-63 (Impact of a deton wave on a rigid wall is similar to collision of two waves); 268-78 (Stationary two-dimensional problems on the scattering of deton products); 279-84 (A diverging spherical deton wave) 61) R.F. Chaiken, *JChemPhys* **33**, 760 (1960) (Comments on hypervelocity wave in condensed expls) 62) Andreev & Belyaev (1960), pp 230-43 (Hydrodynamic theory of detonation waves); 250-52 and Fig 4.61 (Interruption and reformation of detonation wave thru inert solid plates) 63) J.A. Nicholls & E.K. Dabora, "Standing Detonation Waves, USDept Commerce, OfcTechServ PBRept **148528**, 30pp (1960) & *CA* **57**, 14044 (1962) 63a) W.B. Goad, "A Numerical Method for

- Two-Dimensional Unsteady Fluid Flow," LAMS Rept **2365**, (1960) 64) L. Rudlin, "An Approximate Solution of the Flow Within the Reaction Zone Behind a Spherical Detonation Wave in TNT, NavWepsRept **7364** (1960) 64a) J. Zinn & C.L. Mader, JAppl-Phys **31**, 323 (1960) (See under Detonation Wave Structure Measurement in condensed Explosives) 64b) V.S. Ilyukhin, Dokl-AkadN **131**, 793 (1960) (See under Detonation Wave Structure Measurements) 65) Dunkle's Syllabus (1960-1961), pp 14a to 14g and pp 15a to 15f (Structure of detonation wave); pp 17a to 17f, 18a to 18f and 19a to 19e (Detonation in solid expls) 66) M.W. Evans & C.M. Ablow, Chem Revs **61** (1961), p 147 (Definition of term detonation wave); p 152 (Steady detonation waves in real fluids); p 157 (Cylindrically symmetric flow in the steady zone of detonation wave); p 159 (Spherically symmetric flow in the steady zone of detonation wave); p 166 (Stability of detonation waves in which reaction is not complete); p 167 (One-dimensional transient reaction waves); 172, Fig 38 (Instantaneous pre-detonation process in unsteady double-discontinuity system); p 173 (Three-dimensional transient detonation waves, which includes: A) Initiation of detonation waves at a point and B) Detonation waves with fluctuating velocity) 66a) B. Lewis and G. von Elbe, "Combustion Flames and Explosions of Gases", Academic Press, NY (1961) 67) F.W. Ruegg & W.W. Dorsey, "A Missile Technique for the Study of Detonation Waves," JResNatlBur Stds **66C** (51), 8 pp (1961) and CA **59**, 15114 (1963) 67a) W.C. Davis & B.G. Craig, RevSciInstruments **131**, 793 (1961) (See under Detonation Wave Structure Measurements in Condensed Explosives) 67b) D.R. White, PhysFluids **4**, 465 (1961) (See under Detonation Wave Structure Measurements in Condensed Explosives) 68) J.K. Richmond, "Spectrophotometric Analysis of Detonation Wave Structure", Western State College, Combustion Institute, Paper **WSC/CI 61-4**, 32 pp (1961) & CA **58**, 405 (1963) 69) J.A. Nicholls et al. "Experimental and Theoretical Study of Stationary Gaseous Detonation Waves," USDept Commerce Office Technical Services **AD 268927**, 80 pp (1961) & CA **58**, 5444 (1963) 70) R.M. Zaidel, DoklAkadN **136**, 1142-45 (1961) & CA **56**, 5011 (1962) "Stability of Detonation Waves in Gas Mixtures" 71) M. Lutzky, "Spherical Taylor Wave for the Gaseous Products of Solid Explosives," NavWepsRept **6848** (1961) 72) J.R. Travis et al, "Les Ondes de Détonation", Colloques Internationaux du CNRS (Centre National de la Recherche Scientifique), 28 Aug to 2 Sept 1961, Gif sur Yvette, France, pp 41, 45, 59 & 69; published in 1962 by CNRS, 15 Quai Anatole France, Paris 7^e 73) R.J. Eichelberger, "Les Ondes de Détonation", Ibid, p 363 74) J.A. Fay, "Stability of Detonation Waves at Low Pressure s", pp 3-16 (8 refs), in the book of S.S. Penner & F.A. Williams, Eds, "Detonation and Two-Phase Flow," Academic Press, NY (1962) 75) J.K. Richmond, "Spectrophotometric Analysis of Detonation Wave Structure," pp 17-46 of the book of Penner & Williams 76) V.N. Zubarev & G.S. Telegin, DoklAkad N **147**, 1122-25 (1962) & CA **58**, 7779 (1963) (Calculation of Parameters of Detonation Waves of Condensed Explosives) 77) H. Freiwald & R. Schall, Explosivst **10**, 1-5 (1962) (Detonation Waves) 77a) N.E. Hoskin & B.W. Pearson, "Finite Difference Methods for One-Dimensional Unsteady Flow" Chapt 27 of "Numerical Solution of Ordinary and Partial Differential Equations," edited by L. Fox, Pergamon Press, NY (1962) 78) I. Hazal & J. Comburini, CR **255**, 509-11 (1962) & CA **57**, 14043 (1962) (Calculation of characteristics of explosion waves in pure or diluted Hydrazoic Acid) 79) J.A. Nicholls & E.K. Dabora, "Recent Results on Standing Detonation Waves," 8th Symp Combstn (1962), 644-55 80) D.F. Hornig, "Energy Exchange in Shock and Detonation Waves", InstIntern-SolvayConseilChim **12**, 311-33, discussion 334-39 (1962) (In English) (A review with 30 refs) (CA **61**, 8905 (1964) 81) N. Manson et al, "Vibratory Phenomena and Instability of Self-Sustained Detonations in Gases," 9th Symp Combstn (1963), p 461-69 82) J.A. Nicholls, "Standing Detonation Waves," Ibid, pp 488-98 82a) A.H. Taub, "John von

- Neumann Collected Works", Macmillan Co, NY (1963), Vol 6, p 203 (Laminar detonation wave) 83) A. Ya. Apin et al, ZhPriklMekhan i TekhnFiz 1963 (5), 115-17 & CA 60, 7861 (1964) "The Course of Reactions in the Detonation Waves of Explosive Mixtures." Engl transl by M.E. Bachman, NavWepsRept 9045, NOTS TP 4050, China Lake, Calif (1966) (See description in the text) 84) R.I. Soloukhin, UspFizNauk 80 (4), 525-51 (1963) & CA 60, 360 (1964), "Detonation Waves in Gases" (A review with 125 refs) 85) K. Nawa, KôgyôKayakuKyôkaishi 25 (6), 322-23 (1964) & CA 62, 12966 (1965) "Mechanism of Generation of Elastic Waves by Explosives" 85a) H.H. Calvit, "Motion of the Detonation Products Behind Plane and Spherical Detonation Waves in Solid Explosives", Penn State Univ, Dept of Engrg-Mechanics TechRept 3 (Nov 1964) (Dept of Army Contract DA-36-034-ORD-3576RD) 85b) J. Lubliner, JMech & Phys-Solids 12, 59-65 (1964) "A Generalized Theory of Strain-Rate-Dependent Plastic Wave Propagation in Bars" 86) M. Lutzky, "The Flow Field Behind a Spherical Detonation in TNT, Using the Landau-Stanyukovich Equation," USNOL-White Oak, NOLTR 64-40 (Dec 1964) 87) D.S. Abernathy, Science 146, 1635 (Dec 1964), "Detonation-Wave Phenomena" 88) I.C. Skidmore & S. Hart, "The Equation of State of Detonation Products Behind Overdriven Detonation Waves in Composition B," 4th ONRSympDeton (1965) pp 47-51 (8 refs) 89) R. Chéret, "Theoretical Considerations on the Propagation of Shock and Detonation Waves", Ibid, pp 78-83 90) J.P. Argous et al, "Observation and Study of the Conditions for Formation of Mach Detonation Waves," Ibid, pp 135-41 (*Cisoidal Detonation Wave*, pp 135-38 and *Plane Detonation Wave*, pp 138-40). See also J. Touvenin & J.P. Argous, CR 258, 1725 (1964) 91) B.D. Lambourn & P.W. Wright, "Max Interaction of Two Plane Detonation Waves," 4th ONRSympDeton (1965), pp 142-52 91a) H.M. Sternberg & D. Piacesi, "Interaction of Oblique Detonation Waves in Iron," Ibid, p 153 (Abstract) Complete paper published in the PhysFluids 9, 1307 (1966) 92) S.D. Gardner & J. Wackerle, "Interaction of Detonation Waves in Condensed Explosives", 4th ONRSymp Deton (1965), pp 154-55 (Abstract and comments) 92a) B.M. Butcher & D.E. Munson, "The Influence of Mechanical Properties on Wave Propagation in Elastic-Plastic Materials," Ibid, pp 295-304 93) F. David et al, "Oblique Impact of a Layer of Explosive by a Metal Plate", Ibid, pp 381-85 (Formation of oblique deton wave and of over-detonation wave by such impact) 93a) M.L. Wilkins "The Use of One- and Two-Dimensional Hydrodynamic Machine Calculations in High Explosive Research", Ibid, pp 519-26 93b) A. Vidart et al, "Calculation of Unsteady 2-D Flows by Various Numerical Methods" Ibid, pp 527-37 93c) B.D. Lambourn & J.E. Hartley "The Calculation of the Hydrodynamic Behavior of Plane One-Dimensional Explosive Metal Systems", Ibid, pp 538-52 94) D. Venable & T.J. Boyd, Jr, "Phermex Applications to Study of Detonation Waves and Shock Waves," Ibid, pp 639-47 95) J.H. Lee et al, "Two-Dimensional Unconfined Gaseous Detonation Waves," 10th Symp Combstn (1965)(Pub 1966), pp 805-15 95a) B.G. Craig, "Measurements of the Detonation-Front Structure in Condensed-Phase Explosives," Ibid, pp 863-67 96) B. Koch, BerBunsenges-PhysChem 70(9-10), 1064-68 (1966) & CA 66, 1995 (1966), "Studies of Detonation and Shock Wave Fronts by Using Microwaves" 96a) J. Brossard, et al, "Propagation and Vibratory Phenomena of Cylindrical and Expanding Detonation Waves in Gases", 11th SympCombstn (1966) (Pub 1967), pp 623-33 96b) J.R. Kelly & T.O. Toong, "Detonation Wave in Electromagnetic Field", Ibid, pp 657-64 97) R.A. Strelow et al, "Transverse Wave Structure in Detonations", Ibid, pp 677-82 97a) J.R. Bowen, Phys Fluids 10(2), 290-96 (1967) & CA 66, 8180-R (1967), "Approximations to the Structure of a Laminar Detonation Wave by the Method of Matched Asymptotic Expansions" 98) Anon, "Military Explosives", TM9-1300/TO-11A-1-34 (1967), pp 4-8 to 4-11 (Detonation Wave) 99) R.W. Watson, "The Structure of Low-Velocity Detonation Waves," 12th Symp Combstn, Poitiers, France, July 14-20 1968, (Pub 1969), 723-29 100) M.F. Zimmer, "Similarity Between Wave

Structures of Gaseous and Liquid Low Velocity Detonations," Ibid, 740; and Combustion & Flame 12, 1-4 (1968) 101) M. Cowperthwaite, "Explicit Solutions for the Buildup of an Accelerating Reactive Shock to a Steady-State Detonation Wave", Ibid, 753-59 102) A.G. Istratov et al, "On the Stability of Shock and Detonation Waves in Arbitrary Media", Ibid 779-90 103) D.H. Edwards, "A Survey of Recent Work on the Structure of Detonation Waves," Ibid, 819-28 104) B.V. Voitsekhovskii et al, "Investigation of the Structure of Detonation Waves in Gases," Ibid, 829-37 105) A.K. MacPherson, "The Three-Dimensional Wave System of Spinning Detonation," Ibid, 839-50 106) R. Chéret & J. Brossard, "Cylindrical and Spherical Detonations in Gases," Ibid, Abstracts of Papers, p 149 107) G.G. Bach et al, "Direct Initiation of Spherical Detonations in Gaseous Explosives," Ibid, 853-64 108) Jack Alster of Picatinny Arsenal, private communications, Jan-Dec 1969 109) Dr Pai-LenLu of Picatinny Arsenal, April 1970

Detonation, Wax-Gap Test in. See Vol 1 of Encycl p VIII, under "Booster Sensitivity Test" and also on p A 354, Footnote c, entitled "Wax Gap Test"

Detonation, Weak. See under Detonation, Strong and Weak and Also Ref 29

Detonation Whole Cartridge Sensitivity Test. See under DETONATION (AND EXPLOSION) BY INFLUENCE

Defonation (and Explosion), Work Capacity in.

The theoretical work capacity of an explosive can be expressed as the total energy liberated per unit weight during detonation and subsequent cooling of the products to the initial temperature. However, this is not true from a practical viewpoint. The effective work is determined by the energy liberated prior to attainment of maximum pressure by the detonation products. Any additional energy liberated by subsequent reactions of these during expansion and cooling (shifting of equilibrium) does no effective work

This means that if it is desired to calculate the effective work potential of an explosive, it is necessary to calculate or assume the water-gas reaction constant of the detonation products behind the reaction zone, calculate the heat liberated by the decomposition reaction at this equilibrium (Q_c) and calculate the pressure developed on the basis of the gaseous products. A simple approximation of this value can be arrived at by multiplying the heat value Q_c by the volume of gas formed at the maximum temperature but expressed as volume at standard temperature and pressure (V_s)

It is to be noted that the total effective work capacity of an explosive usually has two resultants - (1) fragmentation and (2) blast effect or the movement of matter. These can be measured separately. As there is no shattering effect in the ballistic pendulum test, this test may be considered to measure total effective work capacity

Ref: W.H. Rinckenbach, Private communication, Allentown, Pa, Feb 20, 1964

Detonation, ZND (Zel'dovich-von Neumann-Doering) Model. See Detonation NDZ (Neumann-Döring-Zel'dovich) Theory, pD454

Detonation of a Zebra Charge. Accdg to Taylor (Ref 2), Paterson (Ref 1) has shown that intense illumination is emitted from granular common salt when it is placed in alternate

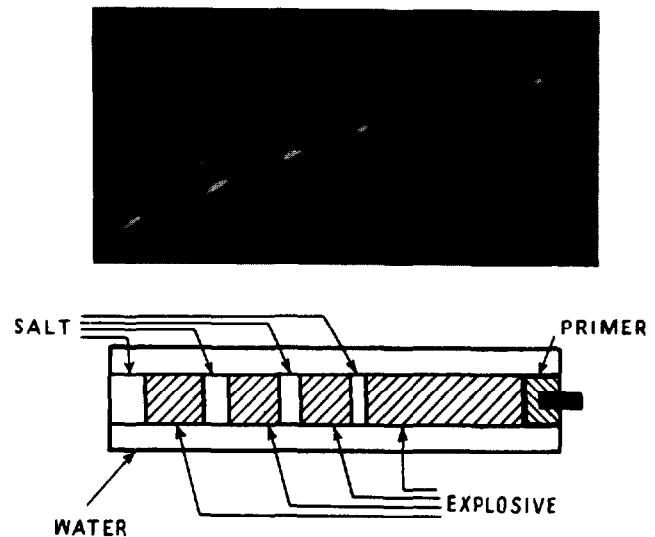

PLATE IX Photograph of a 'zebra' charge, showing intense luminosity in salt zones

layers with a very dense plastic expl and the resulting *zebra charge* is fired in water. The explosive which is almost completely devoid of air, emits very little light and makes only a very faint trace on the film (See plate IX reproduced from Ref 2)

Refs: 1) S. Paterson, *Nature*, **167**, 479 (1941)
2) Taylor (1952), p 174

Detonation Zone. See under DETONATION (AND EXPLOSION) WAVES (Their Relation to Detonation Front, Detonation Zone, and Reaction Zone) See also W.G. Penney, *PrRoySoc* **204A**, pp 5-6 (1950) and C.G. Dunkle, Lectures at Picatinny Arsenal May 1952 & Dec 1955. Also his Syllabus (1957-58), pp 2 & 189-90

Detonative (and Explosive) Combustion or Explosive Deflagration. The normal combustion of homogeneous gas mixts usually occurs at a rate which is governed by the multiple diffusion processes within and in the neighborhood of the flame front. These processes are leisurely, and the propagation rates or "flame speeds" associated with such combstn are of the order of a few meters per second. In the latter part of the 19th century, however, the French scientists Berthelot & Vieille (Ref 1), Mallard & LeChatelier (Ref 2), and Hugoniot (Ref 3) noted in the course of their investigations with combustible mixts, that under certain conditions combstn waves were developed which possessed the velocities of thousands m/sec. Slightly later Chapman (Ref 4) and Jouguet (Ref 5) independently advanced the explanation that such phenomena could be accounted for if this "detonation wave" was treated as a shock wave followed by combustion - the combstn, in turn, being initiated by the high temps accompanying the shock rather than by the diffusion processes mentioned above. This phenomenon is called "explosive combustion" in Ref 6, "detonative combustion" in Refs 7 & 8 and "explosive deflagration" in Refs 9 & 10

With the exception of minor alterations and elaborations, this theory remains unchanged up to the present

Most of the theoretical investigations of detonation which are to be found in the

literature treat the thermodynamic aspects of the process, with attention being focused on state changes across the wave. The dynamic aspects of the wave are, however, emphasized with the elimination of velocity terms in the conservation equations. By the exclusive use of such analysis, many concepts concerning the dynamics of detonation are rendered indistinct. One purpose of investigation by Morrison, (Ref 7), was to find the functional relationship that exists betw the thermodynamic properties and the dynamic props of a detonating mixture. Detonations for experimental observation are usually produced in the so-called "flame tube," which is a long, one-dimensional duct. This tube is filled with a combustible mixt and ignited at one end.

The ensuing flame propagation, being unstable, continually accelerates along the tube, and with sufficient tube length, produces a detonation. Such an exptl procedure affords few controls, and the flexibility of such a system is quite limited. However the so-called "shock tube" possesses all the desirable qualities that are needed for a detailed study of detonative processes (Ref 8, pp 1 & 2)

A detailed description of shock tube techniques is given in Ref 7, pp 74-97; the experimental results are listed on pp 98-111; and discussion is given on pp 112-18. A brief description of shock tube techniques is given in Section 8, p D522

Refs: 1) M. Berthelot & P. Vieille, *CR* **93**, 18 (1881) & **94**, 149 (1882) 2) E. Mallard & H. LeChâtelier, *CR* **93**, 145 (1881)
3) J. Hugoniot, *Journal de Mathématique (Paris)* **3**, 477 (1887) and *Journal de l'École Polytechnique (Paris)* **57**, 3 (1887) & **58**, 1 (1889) 3a) P. Vieille, *MP* **4**, 20 (1891)
4) D.L. Chapman, *PhilMag* **47**, 90 (1899) & *JCS* **76** II, 591 (1899) 5) E. Jouguet, *Journal de Mathématique* **1905**, 347 & **1906**, 6; "La Mécanique des Explosifs", O.Doin, Paris (1917) and "La Théorie Thermodynamique de la Propagation des Explosions", pp 12-22 in the *Proceedings of the 2nd International Congress of Applied Mechanics*, Zürich, Sept 1926 5a) H. Kast, *SS* **15**, 195 (1920) 5b) A. Schmidt, *SS* **33**, 312 (1938)
6) A. Ya. Apin, *DoklAkadN* **50**, 285-88 (1945);

CA 44, 10322 (1950) & 47, 865 (1953) (Detonation and combustion of expls) 7) R.B. Morrison, "A Shock Tube Investigation of Detonative Combustion", UnivMichEngrg-Research Inst Report UMM-97, Ann Arbor, Mich (1952) 8) J.A. Nicholls et al, "Detonative Combustion", UnivMichResearchInst, Final Rept Project M898 (1953) [Contract No AF33(038)-12657] 9) M.A. Cook, p 370 in Clark & Hawley (1957) 10) Cook (1958), pp 172-74 11) Baum, Stanyukovich & Shekhter (1959), p 299 12) Zel'dovich & Kompaneets (1960), 218-22 13) Yu. N. Denisov & Ya. K. Troshin, "On the Mechanism of Detonative Combustion", 8th SympCombstn (1962), pp 600-10

Detonative Ignition in Gases. It was shown by Soloukhine (Ref 1) that in some shock-compressed gaseous systems at constant pressure, one could observe a distinct change in the ignition and detonation processes at a given temperature. In the paper of Voevodskii (Voyevodskii) & Soloukhine (Ref 2) are shown typical schlieren streak photographs and oscillograms characterizing various ignition mechanisms in reflected shock waves

Understanding of the gaseous detonation processes has been significantly enhanced by the use of the stroboscopically operating light source for schlieren photography and a rotating mirror camera. Such a system was developed at the Laboratory of the College of Engineering, Division of Aeronautical Sciences, University of California, Berkeley, Calif and described in Ref 3. Among the experiments conducted at that laboratory on transition to detonation in hydrogen-oxygen mixtures (Ref 4), the most interesting and most appropriate for critical analysis proved to be detonative ignition induced by the shock merging process that sometimes takes place ahead of the accelerating flame (Ref 5). The reason for it is the fact that the results in this case lend themselves to the determination of kinetic induction times without the obscuring effects brought about by the turbulent flame

The paper presented by Urtiew & Oppenheim at 11th SympCombstn (Ref 5) describes an experiment in which a mixture $4\text{H}_2 + 3\text{O}_2$ initiating

at 0.1 atm and 300°K is ignited in a 1x1.5 in ch cross section, 15 ft long tube, by a glow coil at a closed end, 10 ft away from the test section where the process is viewed over a length 1.5 ft by a schlieren-system described in Ref 3. It was claimed, in conclusion, that the detonative ignition induced by shock merging in the above mixture is the transition produced by a chemico-kinetic branched-chain explosion

Refs: 1) R.I. Soloukhine, DoklAkadN 122, 1033 (1958) and the book in Rus "Shock Waves and Detonation in Gases", FM, Moscow (1963) 2) V.V. Voevodskii & R.I. Soloukhine, 10th SympCombstn (1965), 279-83 3) A.K. Oppenheim et al, PrRoySoc 291A, 279 (1966) 4) P.A. Urtiew & A.K. Oppenheim, Ibid 295A, 13 (1966) 5) P.A. Urtiew & A.K. Oppenheim, "Detonative Ignition Induced by Shock Merging", 11th SympCombstn (1967), 665-70

DETONATORS, IGNITERS, PRIMERS, AND OTHER INITIATING DEVICES USED FOR NONMILITARY AND MILITARY PURPOSES

Preface

In the pages which follow, this subject is treated separately for items used for non-military and military purposes. As the subject is very extensive, it is separated into several sections. The references and additional references given at the end of this compilation apply to all sections

The items used for military purposes include those used for small arms ammunition, artillery ammunition, rocket ammunition, aircraft bombs, land & sea mines, grenades, demolition devices and pyrotechnic devices. As some items (such as detonators, primers, etc) can be used in several kinds of ammunition our write-up might contain some repetitions

Section 1

DETONATORS, IGNITERS AND PRIMERS USED FOR NONMILITARY PURPOSES

Part A

Nonmilitary Igniters

Igniters, which include devices called *squibs*, *lighters* and *firing devices*, etc are used for initiating expl or pyrotechnic compns whose nature is such that it is desirable to use flame or flash for their initiation and not a shock as produced by primers or detonators. Explosives of this kind are known as deflagrating or low explosives. BkPdr and smokeless propellants are examples. The simplest device for ignition is *Bickford or Miner's safety fuse*, described in Ref 44, p B112-L. In Ref 50, pp 96-101 is described the safety fuse and the following devices for igniting it: ordinary matches, lead spitter fuse lighter, *ignitacord* and *quarrycord*. The *lead spitter fuse lighter* consists of a thin lead tubing filled with BkPdr and wound on a reel. After cutting with a knife a piece of tubing, the powder is ignited with a match and lighted end approached to the open end of safety fuse. The continuous spit of flame of intense heat will ignite the fuse, making the slitting of

fuse unnecessary. The *pull wire fuse lighter* consists of a paper tube closed at one end and contg an igniting device consisting of a striker compd on a wire which protrudes thru the closed end. In use, the safety fuse is inserted into the open end of the lighter until it slightly touches the wire. It is held in place by means of metal gripper teeth on the inside of the tube. Then the protruding wire is pulled and this ignites the striker compd and the fuse. The *hot wire fuse lighter* consists of a wire covered with an ignition composition that burns slowly with intense heat, and at a fairly steady rate. The device is lighted by a match and the flame is held against the freshly cut end of safety fuse. *Ignitacord* is a device cord-like in appearance which burns progressively along its length. The flame is short and hot and offers a means of lighting a series of safety fuses in the desired rotation. Two types, A & B, are manufd by the DuPont Co. The use of "ignitacord" is described in Ref 50, pp 130-33. *Quarrycord* is another cord-type burning igniter designed mainly for firing a large number of quarry charges in secondary blasting. The use of "quarrycord" is described in Ref 50, pp 133-34. "Secondary blasting" follows quarry blasting operations in order to break up large rock chunks and boulders into pieces sufficiently small to feed into crushers (Ref 50, p 347)

The DuPont Co makes also electric igniting devices, called *electric squibs* (Ref 50, pp 94-5). Three types of US electric squibs patented by Burrows et al, are described in Ref 44, pp B212 to B214

No description of British devices corresponding to US electric squibs is found in Brit books on explosives in our possession, such as Refs 36, 38 & 51. In Ref 38, p 59 is, however, a description of an electric device which probably serves the same purpose. It is an *electric powder fuse*, which consists of a thick paper tube contg a small chge of Blasting Powder (Brit for Black Powder or Gunpowder), with an ordinary low-tension fusehead fixed at one end. On passing electric current thru the fusehead it flashes and sets off the BkPdr in the tube, which can

NOTE: All References are listed in Section 7, pp D1023 to D1055

then ignite the main chge of BkPdr in the shot hole. This device was created so that electrical shot-firing methods could be used for initiating deflagrating expls like BkPdr

In the DuPont's Hdb (Ref 50, p 187), the device consisting of a paper cartridge of BkPdr in which a safety fuse is inserted is called *black powder primer with safety fuse*, and the device combining a BkPdr cartridge with an electric squib or cap is called *black powder primer with electric squib or cap*. As these devices are used for igniting and not for detonating low expls like BkPdr, their correct names should be "igniters"

Section 1, Part B Nonmilitary Primers

Primers used for nonmilitary (commercial or industrial) purposes are devices which initiate high explosive charges (such as Dynamites) by shock produced on detonation of primary charges and not by a flash or flame as in the case of igniters

One of the simplest primers is a combination of "nonelectric cap" (Brit "plain detonator") with safety fuse (Bickford fuse) and a cartridge of Dynamite, as shown in Fig 1. This combination is called in US

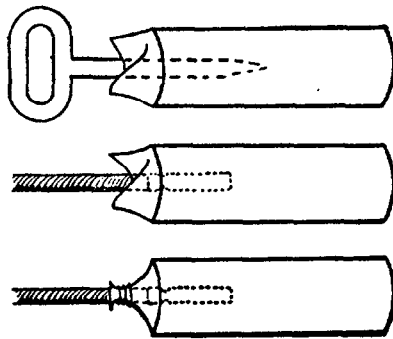

Fig 1 DYNAMITE PRIMER

"Dynamite primer" and in Gt Britain "primer cartridge". For its preparation, one cuts across a safety fuse with a clean sharp knife (or fuse-cutter) a required length and inserts freshly cut end into open end of blasting cap. Using a proper crimping tool, the cap is crimped near its open end to hold the fuse securely in position. This combination is

known in Gt Brit as "capped fuse". The next step is to open the Dynamite cartridge at one end and to make a hole with an Al, Cu, brass or wooden pricker, then to insert the cap into the hole and to tie the cartridge paper tightly around the fuse above the cap (Ref 38, p 71). Other methods of prepn of "Dynamite cartridge" are given in Ref 50, pp 191-94

Electric blasting caps can be used in lieu of nonelectric ones for prepn of primer cartridges. For this, the hole is made in a cartridge of Dynamite as described above and, after inserting the cap, the electric wires of the cap are tied around the cartridge to prevent the cap being withdrawn accidentally during loading or handling (See Fig 2) (Ref 3, p 72 and Ref 50, p 193)

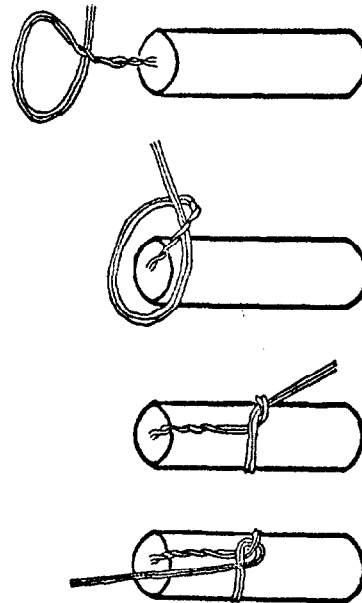

Fig 2 DYNAMITE ELECTRIC PRIMER

Dynamite primers with LEDC (low energy detonating cord) delay assemblies made by the DuPont Co are described in Ref 50, pp 106-09 & 192-93. They are essentially "nonelectric MS (microsecond) delay caps". The LEDC produces very little noise on detonation and for this reason can be used in highly populated areas. It is usually recommended for operations where bottom-hole initiation is desired and electric blasting caps cannot be used for fear of premature detona-

tions from stray current or other extraneous electricity. These primers are assembled the same way as the "capped fuse" (See Fig 1)

"EL-primers" are listed in Ref 50, p 194 as "special non-nitrolycerin primers" designed specifically for priming blasting agents in small diameter boreholes. Their physical appearance is much the same as small diameter Dynamite and the recommended methods of primer assembly are exactly the same as for Dynamite. Their compn is not given in Ref 50

"Sheathed primers" consist of Dynamite cartridge primers inserted in cylindrical paper or cardboard containers of slightly larger ID than OD of cartridges. The caps may be either nonelectric combined with safety fuse, or electric. The sheath prevents the cap from coming out of the cartridge, adds rigidity, and minimizes abuse during loading. These primers have particular merit when boreholes are rough (Ref 50, pp 194-95)

Dynamites and some other mining explosives may be initiated by means of a *detonating fuse*, which acts by producing shock (instead of flash produced by safety fuse). This type of fuse is described in Vol 3 of Encycl under the name of "Cord, Detonating" (Ref 48, p C529) and under "Detonating Cord" (Ref 48, p D103-R). A variety manufd by DuPont Co and known as "Detacord" is described in Ref 48, p D97-L, but not listed in DuPont's Hdb (Ref 50). The "detonating fuse" manufd by the Ensign Bickford Co of Simsbury, Connecticut known as "Primacord" or "Primacord Bickford" is described in Ref 48, p D103 and in Ref 50, pp 101-02. "Primacords" are also manufd by the DuPont Co. Four types of "Primacords": "Reinforced", "Plastic Reinforced", "Plastic Wire Countered", and "E-Cord" are described in Ref 50, pp 103-06.

Detonating cords (fuses) are also used for military purposes. US military requirements and testing are described in Ref 48, pp D104-R to D107

The method of priming dynamite with "Primacord" ("detonating fuse") is described in Ref 38, pp 72-3 and in Ref 50, pp 195-96. When this method is used it is

desirable that the Primacord extend to the bottom of the borehole and therefore it should be attached to the first cartridge loaded into the hole. The cord will initiate every dynamite cartridge in contact with it. Primacord itself can be initiated by means of a blasting cap attached to outer end of the cord. Two methods of prepn of primer cartridges with detonating fuse are shown on Fig 3

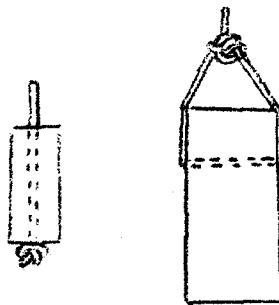

Fig 3 PRIMACORD PRIMER FOR DYNAMITE

Priming with "Nitramon" and "Nitramex 3" primers is described in Ref 50, p 196-98. Since they are packed in metal containers, there is a potential hazard in loading them into a borehole following dynamite or other conventional expls. They are intended only for charges of "blasting agents" under most conditions. They are waterproof

A commercial *blasting agent* is a cap insensitive chemical compn or mixture, which contains no NG and can be detonated only when initiated with a high strength explosive primer. DuPont offers two groups of cap insensitive compns. The 1st group is classified as "oxidizing materials" because they contain no HE's, and are known as "Nitrocarbo-nitrates". Examples of this group are "Nitramon", "Nitramite", and "Nilite". The 2nd group which includes "Nitramex" 2H, HD & 3, as well as "Tovex" and "Pelletol" contain non-NG HE ingredients and for this reason are not true "blasting agents", but are similar to them because they are cap-insensitive (Ref 50, p 47). No compns of the above expls are given in Ref 50

Recommended methods of priming Dynamite charges in boreholes are described in

Ref 50, pp 200-206. They are shown here diagrammatically on Figs 4, 5 & 6

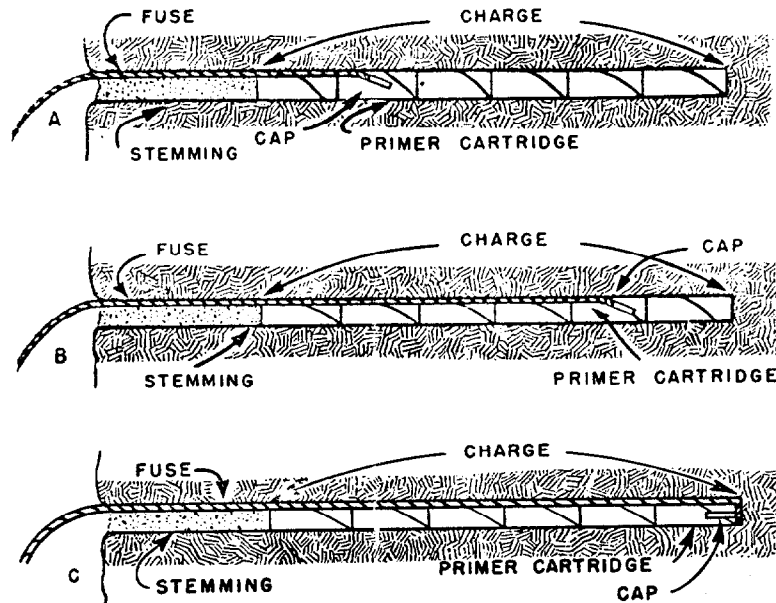

Fig 4 PRIMING OF DYNAMITE CHARGES FIRED WITH CAPS AND SAFETY FUSES

In Fig 4, Method A is for single shots; Method B is for multiple shots or rotation firing in wet holes; and Method C for multiple shots or rotation firing in dry holes or for wet holes providing plastic covered fuse is used

In Fig 5, Method A is for firing with instantaneous electric blasting caps; and Method B is for instantaneous firing and for all rotation firing with delay electric blasting caps

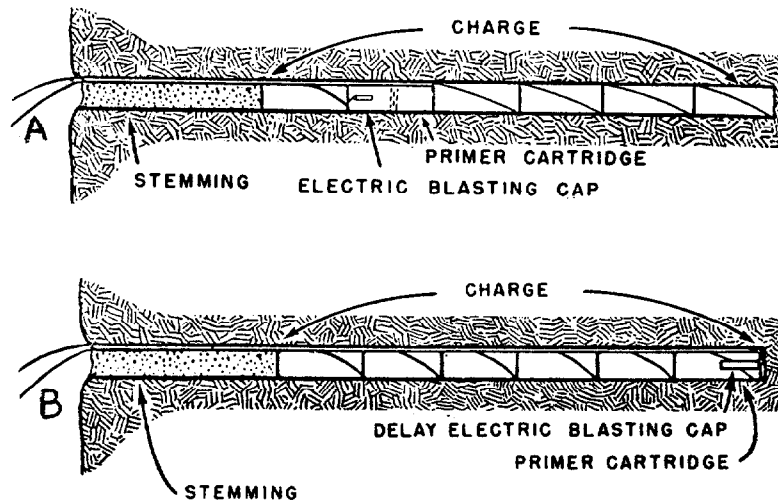

Fig 5 PRIMING OF DYNAMITE CHARGES FIRED WITH ELECTRIC BLASTING CAPS

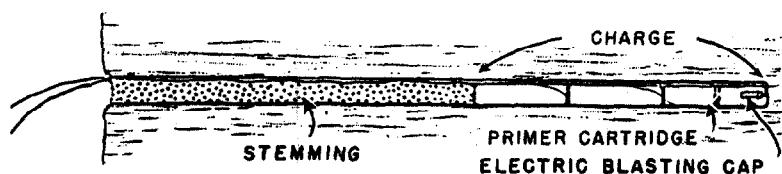

Fig 6 INDIRECT PRIMING OF
PERMISSIBLE EXPLOSIVES

In Fig 6 is shown indirect priming method recommended in blasting permissible dynamite

Indirect priming of the charge means the placement of the cap in the 1st cartridge going into the borehole with the business end pointing toward the collar. In contrast to this, *direct priming* is where the cap is placed in the last cartridge going into the hole and pointed toward the bottom. Indirect priming is safer than direct priming for the reasons listed in Ref 50, p 204

Section 1, Part C Nonmilitary Detonators

Detonators, used for nonmilitary purposes are commonly known in US as *blasting caps* and they are described in Ref 44, pp B185 to B201, where also numerous references are given. In some US Bureau of Mines publications they are called "detonators". For example, Grant & Coates (Ref 7a, p 2) stated that "Detonators are used to explode permissible explosives, dynamites, or other high explosives. This explosion or detonation is brought about by the energy which is liberated as a combination of concussion and heat when the detonator is fired"

The *blasting caps* are subdivided into *nonelectric caps*, which can be *single-component* and *compound caps*, also called "two-part detonators" (Ref 44, pp B185 to B186-R); *electric caps*, which can be *high tension*, *low tension* and *match-head type* (Ref 44, pp B186-R to B188-L); and *delay electric cap* (p B188-L) There are also a *special blasting cap*, suitable for seismographic explorations and *US Army special blasting caps*, nonelectric and electric (Ref 44, p B188-R). "Western Big Inch Blasting Caps" are briefly described in Ref 44, p B186-R

In Gt Britain devices corresponding to US

blasting caps are called *commercial detonators*. Originally devices corresponding to US *non-electric caps*, known in Gt Britain as *plain detonators*, contained a single expl chge consisting of a mixture of 80% MF & 20% K chlorate. There was a series of ten detonators and the wt of MF mixt in the No 6 detonator was 1g. Later a switch was made to the (Azide-Styphnate-Aluminum) *ASA/Tetryl detonator* (Ref 43, p A493-R) and only No 6 & No 8 detonators continued to be manufd. For example the No 8, manufd by the Nobel Society, contained 0.35g of LA-LSt mixture and 0.55g of Tetryl (Ref 29a, p 77). The most recent change has been the substitution of PETN for Tetryl, which gave *ASA/PETN detonator* (Ref 43, p A493-R) (See also Ref 36, p 54 and Ref 38, p 52-3). Although each of these detonators contain two charges: priming or upper (ASA) and secondary or base (Tetryl or PETN), they are still called in Gt Brit the "plain detonators". Corresponding devices are known in US as *compound blasting caps* (See Ref 44, p 186-L and Fig), but the ASA detonators have no "reinforcing cup", as do the US caps

German detonators known at the time of WWII are described in Ref 35, pp Ger 34 & Ger 35. The *Briska* detonator which originated in Germany before WWII is described by Stettbacher (Ref 3, p 348) and in Ref 35, p Ger 23. In the *Briska* version of detonator manufd in Gt Britain, the priming charge is LA/LSt mixture, while the secondary (base) charge is loaded in two stages: the 1st at a very high pressure (28400psi) and the 2nd or "intermediate" chge at the lower pressure of 400psi. The highly compressed portion is difficult to initiate and the low compressed portion acts as a booster to ensure detonation. The No 6 *Briska* is more powerful than No 8 ASA detonator (Ref 22a, p 11). Simi-

lar description is given in Ref 38, p 35

In the book of Fordham (Ref 51, p 108-09) are described Brit "plain detonators", such as No 6, which contains as a base chge 0.24g PETN and No 8 *Star*, which contains 0.8g PETN. As a priming charge, in both cases, a 2/1 mixt of dextrinated LA/LSt is used with ca 3% Al powder and, sometimes, 3% Tetryl added

Electric blasting caps (or electric blasting initiators) are described in Ref 44, pp B186-R to B186-L. Such caps are called "electric detonators" in Gt Britain. The type known as the "neoprene plug assembly"; is described in Ref 36, pp 56-8 and Ref 38, pp 53-6 and is shown here in Fig 7. It consists

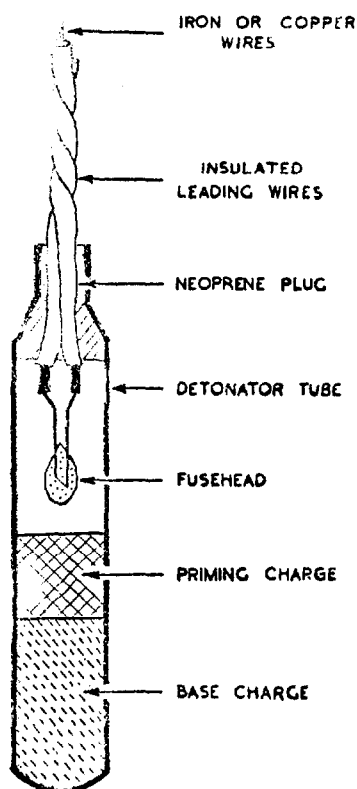

Fig 7 NEOPRENE PLUG ASSEMBLY
(ELECTRIC DETONATOR)

of an Al or Cu tube contg base & priming charges, fusehead (also known as match-head), leading wires and neoprene plug. The function of the plug is to provide a completely water-proof seal at the open end of detonator

When used in permitted expls Cu tube must be used because Al might ignite and its flame will cause firedamp explosion

Low tension fusehead, described in Ref 36, p 58 and Ref 38, pp 54-5 is shown here in Fig 8.

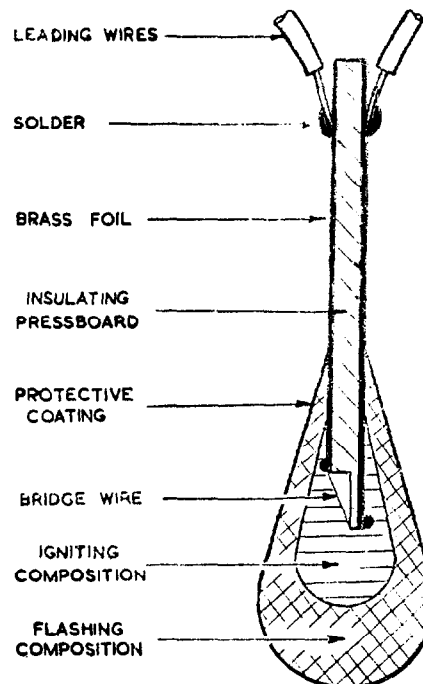

Fig 8 LOW-TENSION FUSEHEAD FOR
ELECTRIC DETONATOR

It consists of two brass foils, separated by a layer of insulating pressboard. At one end the two leading wires are soldered, one to each foil, and at the other end the two foils are connected by a very fine high resistance bridge wire. A bead of ignition composition is formed around the bridge. The bead is made of several layers and the innermost consists of a readily ignitable mixt of K chlorate & Pb mononitroresorcinate, with a little NC. This is then surrounded by a flashing compn, such as mixt of K chlorate & charcoal (which produces a hot and vigorous flash) and finally the bead is dipped into a protective coating of NC soln. After drying, the fusehead and neoprene plug are inserted thru the open end of tube and the tube is crimped as shown on Fig 7

Fordham (Ref 51, pp 116-19), calls the fusehead of Fig 8 the *Sandwich type fusehead* and states that it was invented by Krannichfeld in Germany. Judging by the description of its method of manuf, it is similar to German fuseheads described in Ref 35, pp Ger 53 & Ger 54

Fordham describes four types of Brit commercial electric detonators (Ref 51, p 116, Fig 10.1). The first three types are "low tension bridge detonators" and correspond to US electric blasting initiators shown in Fig, p B188 of Ref 44. The 4th Brit type is high-tension, requiring at least 36 volts for its initiation. There is no bridge wire but electric conductivity is achieved by incorporating graphite in the flashing compn of fusehead. The use of this type seems to be discontinued in Gt Britain (Ref 51, pp 117-21)

British commercial electric delay detonators are described in Ref 36, pp 69-74; Ref 38, pp 56-9 and Ref 51, pp 125-30. The earliest type introduced in Gt Britain in 1910 had various lengths of Bickford fuse between the fusehead and the detonator proper (Fig 11.1 p 126 of Ref 51). An important feature was a small hole (vent) in the detonator tube, located betw the fusehead and the fuse. The hole initially covered with a tape (which broke on firing) served as a way of escape for gases formed on burning of fuse. This design was necessary to prevent an increase in pressure which could cause too rapid burning of safety fuse. As this might cause irregularity in delay time and premature ignition or expln of main chge, this type of detonator was in many cases replaced by the type of detonator invented by Eschbach. In this new detonator the delay compn (such as a mixt of K permanganate 55-70 & Sb 45-30%), which is used in lieu of safety fuse, evolves so little gas that there is no necessity for a vent. This detonator eliminates the risk of premature expln and makes it possible to provide fully waterproofed assemblies which give delay times much more regular. Such "gasless" delay detonators are usually manuf in series to fire at prearranged delay times with intervals of time 1 or 0.5 secs betw the numbers. The so-called *millisecond*

or *short delay* detonators are manufd with intervals betw each number of the series varying betw 25 and 50 milliseconds (Ref 51, pp 125-27)

Two types of British "electric delay detonators": the "early vented type" and the "modern unvented type" are shown in Fig 9 (Ref 51, p 126)

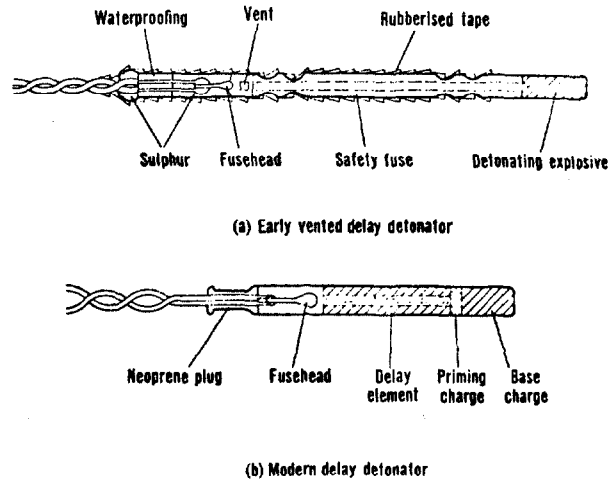

Fig 9 TWO TYPES OF BRITISH ELECTRIC DELAY DETONATORS

A type of British "electric delay detonator with an intermediate charge" is described in Ref 36, p 70 and is shown here as Fig 10.

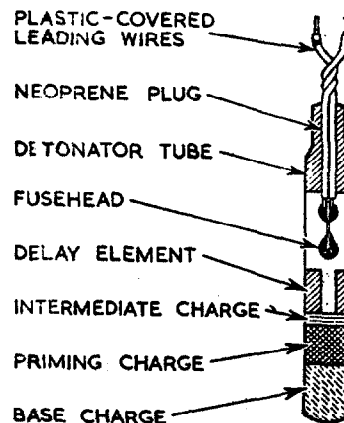

Fig 10 BRITISH ELECTRIC DELAY DETONATOR WITH AN INTERMEDIATE CHARGE

It consists of a thin-walled metal tube closed at one end and loaded with base chge, priming chge, intermediate chge, a delay element (which consists of a thick metal tube loaded by compression with a slow-burning compn), a fusehead and neoprene plug. When the fusehead is fired by electrical current, it ignites the delay compn and this initiates the intermediate, priming and base chges. Both the fusehead and the delay compn are practically "gasless". This is achieved by using mixts which produce on combustion no gases but solid metallic oxides. The fusehead consists of a mixt of rare-earth metals & metallic peroxide, while delay compn is a mist of Sb powder & K permanganate (Ref 36, p 70)

Another type of British nonmilitary electric detonator, called "short type delay detonator" is described in Ref 36, pp 72-3 and is shown here in Fig 11. This detonator con-

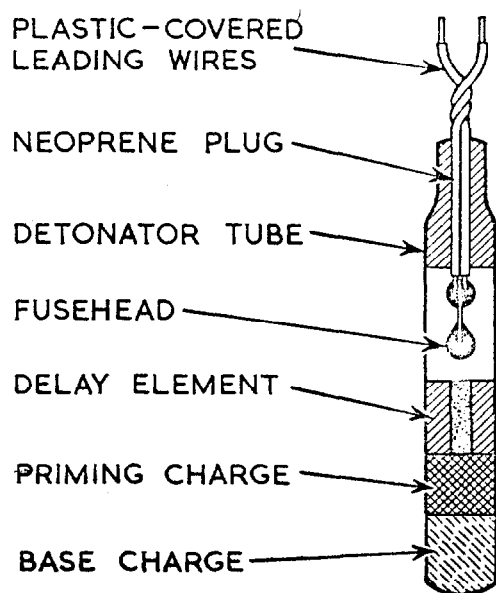

Fig 11 BRITISH ELECTRIC SHORT DELAY DETONATOR

sists of a copper tube closed at one end and filled with charge for No 6 strength mixture. Its base chge comprised of Tetryl or PETN and the priming chge is a mixt of LSt/LA/Al powder & binding agent consolidated together by pressure. Above these comes the delay element consisting of a thick brass tube loaded in pressed increments with a granulated mixt of red lead and silicon (or with some other mixt). Ignition is achieved by a

"gasless" type of low-tension fusehead (such as a mixt of rare earth metals and metallic peroxide). The closure is effected by the neoprene plug seal which has been found very satisfactory for the standard gasless delay detonators. With this type of closure it is practically impossible to pull out the leading wires or disturb the internal part of the detonator by any pull which can be brought to bear on the wires (Ref 36, pp 71-3)

Ordinary delay detonators in Gt Britain are issued in series numbered from 0 to 10, the interval betw any two consecutive delay numbers being 0.5 sec. Thus the No 0 fires instantaneously, No 1 fires 0.5 sec later, etc (Ref 36, p 71)

Short delay detonators standardized in Gt Brit in 1956 number 15 and their periods run from 0 for No 0 to 700 milliseconds for No 15. For No 1 it is 25 msec, for No 2 - 50, for No 4 - 100, for No 10 - 345, etc (Ref 36, p 73 and Table 2, p 74)

Firing characteristics of Brit electrical detonators are given in Ref 51, p 121

Devices similar to above electric delay detonators are described in Ref 44, p B188-L, under BLASTING CAPS and in Ref 48, pp D49-R & D50-L, under Delay Blasting Cap. The description includes two types of electric delay caps of DuPont Co and a *nonelectric delay blasting cap* (pB50-L). Composition of various *delay elements* are given on p B52

Fordham (Ref 51, p 127) states that a common mixture for US delay elements consists of Ba peroxide 85 & Se 15% and that for the manuf of millisecond delay detonators, faster burning compns are required such as Si 30-50 & red lead (or lead dioxide) 50-70%. Manuf of delay compns is described on pp 128-29, assembly on p 129 and design on pp 129-30 of Ref 51. Ger delay compositions (Verzögerungsverbindungen) and delay elements (Verzögerungskörper) are described in Ref 35, pp Ger 33 & Ger 34

Taylor & Gay (Ref 36, pp 62-4), discuss "principles of series "shotfiring"; where they explain why the current needed to fire a series should be greater than that required to fire a single electric detonator. If a uniform direct

current is applied to a series of electric detonators, before any one detonator can fire, the fusehead must be traversed by the current for a certain period of time (usually of the order of milliseconds) during which time the bridgewire heats up to a temperature at which the sensitive compn of the fusehead ignites and fires the detonator. The minimum time is called the "excitation time" and this is shown in Ref 36, p 63, as Fig 10, which is given here as Fig 12. After the fusehead receives the minimum amt of current there will normally be a further small time lapse before the ignition spreads thru the fusehead and communicates to the priming charge of detonator. This is the moment at which it is considered that the electric circuit of detonator is broken. The time from the first application of current to the rupture of the circuit is referred to as the "lag time" and the time between the first application of the current and the detonator firing, is called the "bursting time". The difference betw the lag time and the bursting time is referred to as the "induction time"

For firing successfully a series of detonators it is required that the shortest "lag time" of any of them must exceed the longest "excitation time" of any of them. In other words, every one of the detonators must receive the full quota of electric energy to cause its ignition before any single one of them has completed its "lag time"

The firing characteristics of commercial electric detonators are shown in Ref 36, p 64, Fig 11, given here as Fig 13. The curve APB of Fig shows the relation between current i and "minimum lag time" for the most rapid detonator in the series, while the curve CPD shows the corresponding relation between current and "maximum excitation time" for the least sensitive detonator of the series. From the curve it can be seen that with current i_1 , the most rapid detonator will break the circuit in T_4 milliseconds, whereas the least sensitive detonator requires at least T_5 millisecs of current flow to enable it to fire. At a higher current i_2 , however, the excitation time T , is less than time T_2 which is allowed by the most rapid detonator, and hence the least

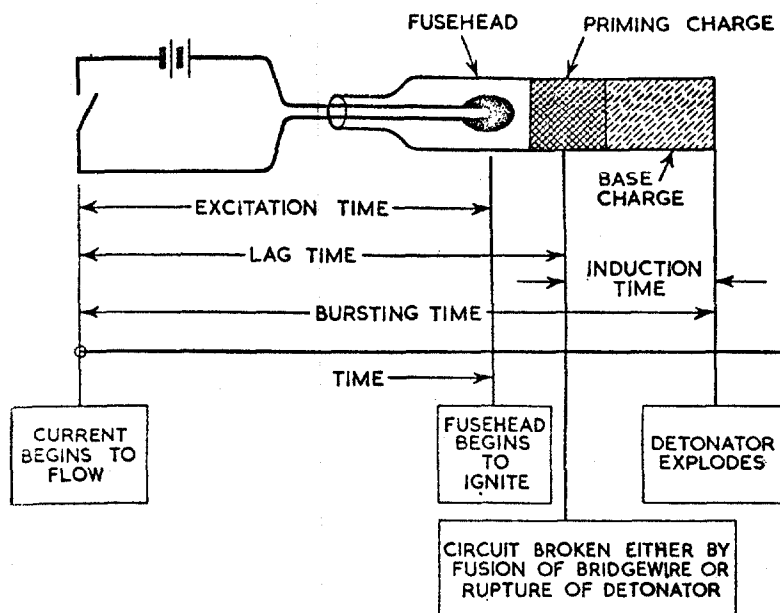

Fig 12 THE SEQUENCE OF EVENTS IN FIRING ELECTRIC DETONATORS

sensitive detonator in the circuit will have ample time to receive its full quota of current before the circuit is broken at T_2 . Somewhere between the two current values i_1 and i_2 , corresponding to the crossover point P, there must be value i_0 which will be minimum firing current of a single electric detonator of the same type, and this is the reason why series firing requires a higher current than simple firing

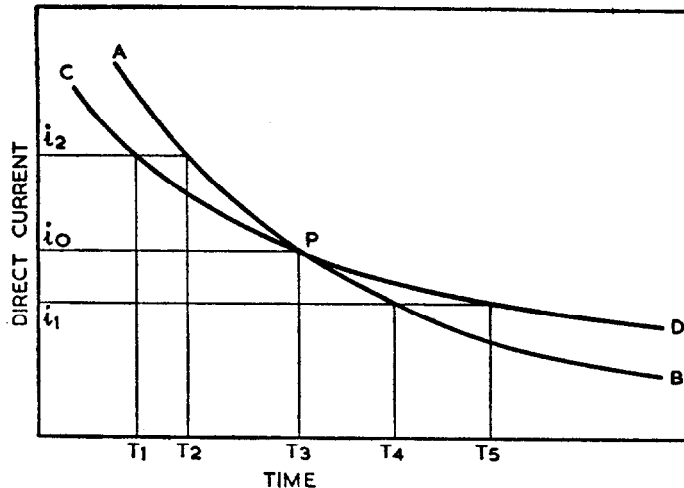

Fig 13 THEORY OF SERIES FIRING WITH TWO TYPES OF ELECTRIC DETONATORS

Section 2 DETONATORS, IGNITERS, PRIMERS AND OTHER INITIATING DEVICES USED FOR MILITARY PURPOSES

Preface

Before proceeding with the description of these devices, there is given a Glossary of Ordnance and other terms which will be used in the text of this section. It is done in order to make the subject of initiating devices more comprehensive. If an item mentioned in the Glossary is already described in one of the volumes of this Encyclopedia (listed here as Ref 43 for Vol 1, Ref 44 for Vol 2 and Ref 48 for Vol 3), only its cross-reference is given

At the end of Glossary is given as Part B, the Nomenclature Used by US Armed Forces and in Part C the History of Development of Initiating Devices

Section 2, Part A Glossary of Ordnance and Other Terms Used in This Description of Ordnance Items

Activator (of a Land Mine). It was defined in Vol 1, p A101-L of Encycl (Ref 42) as a fuze, but actually it is a detonator-booster, which acts in conjunction with a firing device, as a *secondary fuze* which provides some A/T mines with antilifting or boobytrapping capabilities. In TM 9-1940 (1956), "Land Mines", pp 110-11 is described Activator M1 which is used in A/T mines M6 & M15 series. The device is ca 2 inches long and is made of a black plastic material. It contains a detonator, has a cylindrical unthreaded cup cemented to the opposite end of the body and contains a Tetryl booster chge (See Fig 14). There is also Activator HE, M2 (RDX-loaded) (Compare with Fuze, Auxiliary, under Fuzes in Section 5, Part A).

Activator, Antitank Mine. It is defined in MIL-STD-444 (Ref 40a, p 2) as "a nonmetallic item designed to adapt a firing device to an antitank mine. It may be empty, inert filled or explosive filled"

Actuator. See Explosive Actuator in this Glossary

Aircraft Ammunition. See Ref 43, p A384-R

Ammunition. See Ref 43, p A383-L & Ref 40a, p 8

AP. Abbr for Armor-piercing

A/P Abbr for Antipersonnel

AT or A/T. Abbrs for Antitank

Auxiliary Detonator, See Detonator, Auxiliary

NOTE: All References are listed in Section 7, pp D1023 to D1055

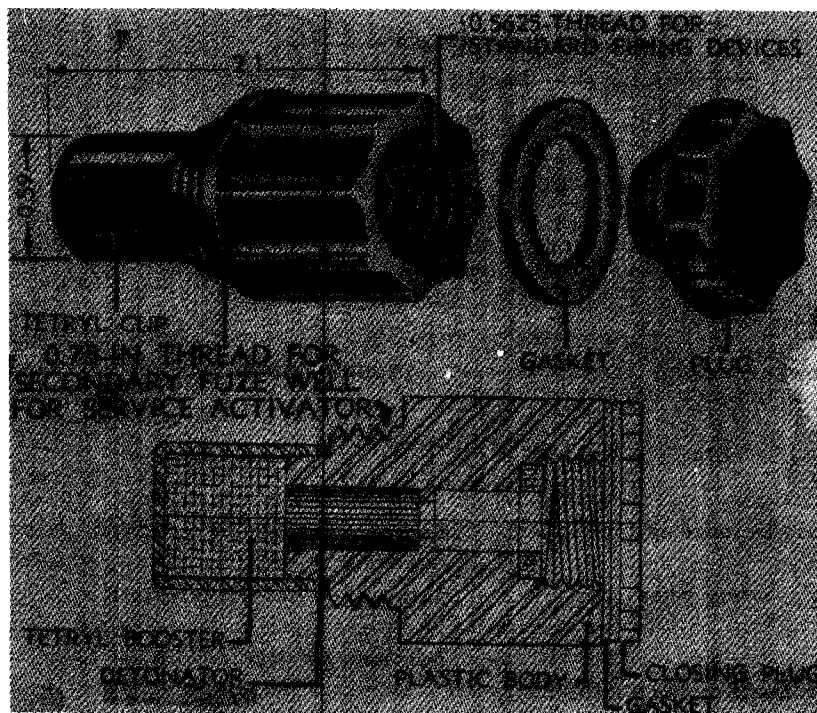

Fig 14 ACTIVATOR M1

Baffle (Used in Delay Elements). When a primer of a delay element is initiated, a high velocity jet (hot gases, slag particles, and fragments of the closure disk or cup) is projected toward the BkPdr pellet. The inertia of these blast components is such as to cause undue penetration of the pellet's surface thereby disrupting a portion of it and affecting the delay time. Such condition is exceptionally serious with obturated delays of small time magnitude, say 0.01 sec, where the impingement of these combustion products will completely disrupt the very small pellet, giving no significant delay. To combat this disruptive force, a *baffle* is employed. Baffles have many forms, but all serve to absorb the energy of slag particles and sealing device fragments by deflecting them. An additional function is to reduce the velocity of the hot primer gases and "ease" them across the surface of the pellet. Baffles are made of the same material as delay element body in order to reduce the possibility of electrolytic corrosion. Brass or Al alloys are usually employed, and occasionally stainless steel. The

size of the baffle is usually dictated by space limitations, but it must be large enough to provide channels of sufficient size to prevent excessive back pressure on the primer cup, which may cause rupture. Channels may be large enough to prevent primer cup failure, but small enough to provide proper ignition of the pellet (Ref 23, pp 5-29 & 5-30). Two types of baffles are shown in Fig 5-26 (See also Section 4, Part F, Delays, Relays and Leads, etc)

In the event that a short delay is desired but space limitations preclude the incorporation of any baffle, the BkPdr pellet should be pressed very strongly to offer resistance to penetration by the high velocity particles

Ballistic Missile. See Ref 44, p B6-L & Ref 40a, p 8

Ballistite. See Ref 44, p B8-L

Base Charge in Detonators, also known as *main charge*, is defined in the text under Detonators, etc

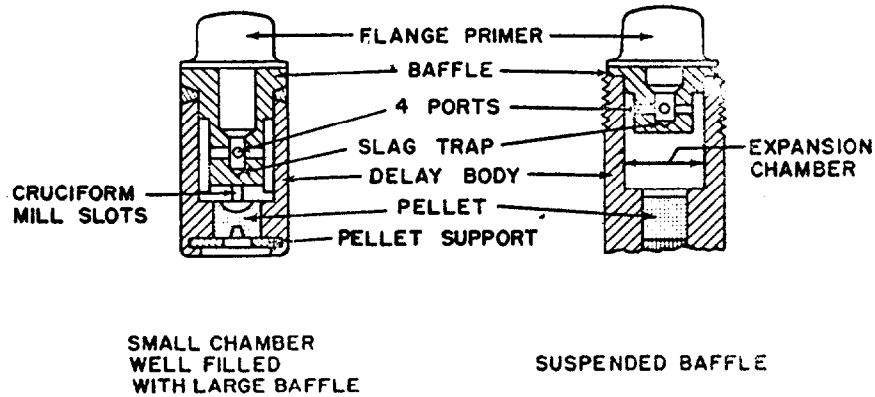

Fig 15 TWO TYPES OF BAFFLES

BD Fuze, Abbr for Base-Detonating Fuze

Bickford Fuse or Miner's Safety Fuse. See Ref 44, p B112-L

BkPdr (Black Powder). See Ref 44, p B165-R

Blasting Cap. See Ref 44, p B185-L & Ref 40a, p 24

Blasting Machine (Exploder). See Ref 44, p B212-L

Blend. Nitrocellulose (NC) contg 13.15 to 13.25% N. See Ref 44, p C103-L

Bomb. See Vol 2 of Encycl (Ref 44), p B225-Rff

Booby Trap. See Ref 44, p B225-R

Boom. An extension of an Ordnance item

Boom Igniter. Such igniters are shown on cutaway illustrations of 90mm HEAT Cartridge M348A1 and 105mm HEAT Cartridge M341 described in Section 3, Subsection D, under Primers and also in Ref 52, p 3-26. The Figs show that percussion primers of these cartridges are threaded into the fin assembly of the *tail boom*. A recess holds the 1st ignition cartridge. Then comes a vent for the transmission of the cartridge gas to the "boom ignition cartridge". This extra cartridge is needed for proper deflagration of propellant charge (Ref 55)

Booster. See Ref 44, p B243

Bullet. See Ref 44, p B324-R

Burster. See Ref 44, p B364-L

Bursting Charge or Main Charge. See Ref 44, p B364

Cannon. See Ref 44, p C26-L and Ref 40a, p 23. The following slightly different definition is given in Ref 45f, p 2-1: "A cannon (general) is a weapon conforming to the general gun definition, that is provided with structure (mount) for mechanical support during firing, and that has a bore diameter exceeding the limit assigned to small arms. (The small arms bore limit is presently administratively set at 30mm). The general category of cannon is further divided, in accordance with ballistic characteristics and use, into guns, howitzers, mortars, and recoilless weapons". A "cannon" (specific), is defined in Ref 45f, p 2-5, as the term used to denote the shooting part of a complete weapon (gun, howitzer, mortar or recoilless weapon) comprising only the tube and breech structures and such mechanism as is supported thereon for opening and closing the breech and firing the propelling charge

Cannon Propellant. See Ref 44, p C29-R

Carbine. See Ref 44, p C51-L & Ref 43, p 4-6

Cartridge. See Ref 44, p C70

Charge (Explosive Charge). See Ref 44, p C150

Cluster. See Vol 3 of Encycl, p C351-L

Collodion Cotton (abbr CC). See Ref 44, p C103, under CELLULOSE NITRATES. Also known as Pyroxylin

Complete Round of Ammunition. See Ammunition, Complete Round in Ref 43, p A385-L

Composite Propellants. See Ref 48, p C464-L

Cord, Detonating or Cordeau. See Ref 44, p C529-R

Cordite. See Ref 48, p C531-R

Cyclonite. See RDX in this Glossary

DADNPh. Our abbr for Diazodinitrophenol

DDNP. Abbr given in TM's for Diazodinitrophenol

Deflagrating Explosives. See Ref 48, pp D38-R and D107-L. Known also as Low Explosives (See in this Glossary)

Deflagration. See Ref 48, p D38-R

DEGDN. Our abbr for Diethyleneglycol Dinitrate

Delay. See Ref 48, p D49 and in this Vol, Section 4, Part F

Delay Blasting Cap. See Ref 48, p D49-R

Delay Charges; Delay Compositions or Delay Powders. See Ref 48, p D50-Lff and Section 4, Part F in this Vol

Delay Detonators. See in this Vol, Section 4, Part F

Delay Explosive Train. See in Ref 48, p D53-L and in this Vol, Section 4, Part F

Demolition Bangalore Torpedoes. See Ref 44, p B16-R

Demolition Explosives. See Ref 48, p D56-R & Ref 53

Demolition Kit or Unit. See Ref 48, p D61-L

Demolition Snakes. See Ref 44, p B17

Destructor. See Ref 48, p D92-R

Detonating Cap. Same as Blasting Cap

Detonating Cord. See Cord, Detonating in Ref 48, p C529-R and Detonating Cord or Fuse in Ref 48, p D103

Detonating Explosive. See Ref 48, p D107-L and also High-Explosive in this Glossary

Detonation. See in this Vol under DETONATION (AND EXPLOSION)

Detonator (Commercial or Nonmilitary); See Section 1, Part C in this Vol

Detonator (Military). See Section 3, Part E and Section 4, Part D

Detonator, Auxiliary. The following explanation is given by Odierno in Ref 45d, p II: "In the development of some items in the past, prior to the use of electrical fuzes for PIBD (point initiated base detonated) fuzes, an explosive component known as an auxiliary detonator was used. This detonator resembled flanged lead cup in outward appearance, however, it was longer, larger in diameter and incorporated a shape charge on the output end. The auxiliary detonator was used to jump the gap from the base of the fuze down through a hollow tube in the shell to a Tetryl or RDX pellet in the bottom of the shell. This was acceptable, however, it was not as efficient as the electrical PIBD Fuze, because of alignment problems, time of functioning, etc"

Detonator, Delay. See in this Vol, Section 4, Part F

Detonator, Electric. See Section 3, Part E and Section 4, Part D

Detonator, Flash. See Section 3, Part E and Section 4, Part D

Detonator-Primer. See Section 3, Parts D & E and in Section 4, Parts D & E

Detonator, Relay. See Ref 48, p D54-L and Section 4, Part F in this Vol

Detonator, Stab. See Section 3, Part E and Section 4, Part D

Double-Base Cannon Propellant
Double-Base Canno

Double-Base Cannon Propellant
Double-Base Propellant } See Ref 44,
p C33-L and in this Vol under Double Base Pro-
pellant

Dud. An explosive-loaded item that fails to explode when subjected to treatment that should cause it to function

Electric Detonator. See under Section 3, Part E and Section 4, Part D

Exploder. See Blasting Machine in Vol 2 of Encycl (Ref 44), p B212-L

Explosive Actuator, Linear. A self-contained power transmitting device designed to convert chemical energy into controlled mechanical force in the form of linear mechanical movement. It is comprised essentially of a piston, propellant chge, electrical bridge wire and contacts enclosed in a housing (Ref 38b, pp 3-4, Actuator, Explosive, Linear)

In MIL-STD-444 (Ref 40a, p 2), it is defined as a Cartridge, Initiator and this seems to be the same as Cartridge-Actuated Devices (CAD's) described in Vol 2, p C70-R of Encycl (Ref 44)

Explosive Train or High-Explosive Train. See in this Vol, Section 3, Part C and Figs 1-20 and 1-21

Firing Devices. See Section 3, Part C and Figs 22, 23, 24, 25, 26, 27 & 28

Fuse, Detonating. See Card, Detonating in Ref 48, p C529-R and Detonating Cord in Ref 48, p D103

Fuse, Electric Powder. See "electric powder fuse" in this Vol under Detonators used for commercial purposes

Fusee (pronounced fuzee). An igniter squib for a rocket motor (Ref 40a, p 75)

Fusehead. A flashing (igniting) element used in electric detonators. See under Detonators in Section 1, Part C; Section 3, Part E and Section 4, Part D

Fuse, Miner's or Safety Fuse. Same as Bickford Fuse

Fuze. A list of various fuzes and description of some of them are given in Sections 5 & 6 in this Volume

Gasless Delays. See under Delays

Grenade. A small explosive or chemical missile which can be either thrown by hand (Hand Grenade), or be projected from the muzzle of a rifle or carbine (Rifle Grenade). Many varieties exist, such as antipersonnel, antitank, chemical, concussion (offensive), defensive, fragmentation, frangible, gas, illuminating, incendiary, practice, riot, smoke and training (Ref 40a, pp 84-51)

Grommet. A device made of rope, plastic, rubber, or metal to protect the rotating band of the projectile (Ref 40a, p 85-R)

Guided Missile (GM). An unmanned self-propelled vehicle, with or without warhead, designed to move in a trajectory or flight path all or partially above the earth's surface and whose trajectory or course, while in flight, is capable of being controlled remotely, or by homing systems, or by inertial and/or programmed guidance from within. Guided missiles may be air-to-air (AAM), air-to-surface (ASM), air-to-underwater (AUM), surface-to-air (SAM), surface-to-surface (SSM), surface-

to-underwater (SUM), underwater-to-air (UAM), underwater-to-surface (USM), and underwater-to-underwater (UUM). Excludes drones, torpedos and rockets and other vehicles whose trajectory or course cannot be controlled while in flight (Ref 40a, p 85). (Compare with Ballistic Missile)

Gun. See Ref 44, p C26-R and the following two characteristics given in Ref 45f, p 2-1:

1) Gun (General) is a projectile-throwing device, consisting essentially of a projectile-guiding tube with an incorporate or connected reaction chamber, in which the chemical energy of a propellant is rapidly converted into heat and the hot gases expand to expel the projectile at a high velocity (kinetic energy). Guns in this general sense are separated, according to size and use, into the general categories of cannon and small arms. Launchers for rockets and missiles are not guns

2) Gun (Specific). In the specific sense used in ordnance supply, a gun is a complete weapon conforming to the general cannon definition; including the attached or closely related units necessary for operation as intended (recoil mechanism, mount, sighting system, accessories, but not ammunition), and designed for performance characterized primarily by relatively long range, high velocity, and relatively little curvature of the projectile trajectory within the intended range. Accordg to Ref 40a, pp 85-6 a gun is a weapon with barrel longer than 30 calibers, and a relatively high muzzle velocity

Guncotton (Nitrocellulose). Nitrocellulose of high nitration (13.35 to 13.4% nitrogen. Used as an ingredient of smokeless propellants (Ref 40a, p 86 and Ref 44, p C103-L

High-Explosive (HE). An explosive which when used in normal manner detonates rather than deflagrates or burns; that is, the rate of advance of the reaction zone into the unreacted material exceeds the velocity of sound in the unreacted material. Whether an explosive reacts as a HE or as a LE (low explosive) depends on the manner in which it is initiated and confined. For example, a double base

propellant when initiated in the usual manner is a LE. However, this material can be made to detonate if it is initiated by shock. Conversely, an HE like TNT, under certain conditions, can be ignited by flame and will burn without detonating. HE's are divided into primary and secondary, according to their sensitivity to heat and shock. This division is not accepted by some authorities who maintain that HE's and primary explosives are entirely separate "entities" (Ref 40a, p 88) (See also Detonating Explosives in Ref 48, p D107-L

High-Explosive Train . See Explosive Train in this Glossary

Howitzer (How). See Ref 44, p B27-L, under CANNON and Ref 40a, p 89. In Ref 45f, pp 2-1 & 2-3 it is defined as a complete weapon conforming to the general cannon definition; including the attached or closely related units necessary for operation as intended (recoil mechanism, mount, sighting system, accessories, etc, but not ammunition), and designed for performance characterized by velocity, range, and trajectory curvature intermediate between those of a gun and a mortar

Igniter (Commercial or Nonmilitary). See Section 1, Part A in this Vol

Igniter (Military). See Section 3, Part C in this Vol

Igniter for Rocket Motor. An explosive item designated to ignite the propelling charge in a rocket motor (Ref 40a, p 90). See also Igniter, Ram-Jet Engine in Section 3, Part C, Fig 29

Impact Force . See Set Forward Force

Initiating Agent. An explosive material which has the necessary sensitivity to heat, friction, or percussion to make it suitable for use as an initial element in an explosive train (Ref 40a, p 92)

Input Characteristics. The characteristics of an explosive component which determine its sensitivity to initiation by externally applied energy (Compare with Output Characteristics)

JATO (Jet-Assisted Take-Off) Unit. See in this Glossary under Rocket Motor and in Ref 43, p A384

LA. Abbr for Lead Azide. See under AZIDES in Ref 43, p A545-L

Land Mine. See Mine in this Glossary and in Ref 43, p A384-R

Lead or Explosive Lead. See in this Vol, Section 4, Part F

Low-Explosive (LE). An explosive which when used in its normal manner deflagrates or burns rather than detonates; that is the rate of advance of the reaction zone into the unreacted material is less than the velocity of sound in the unreacted material. LE's include propellants, certain primer mixtures, BkPdr, blasting explosives (See Ref 44, p B202-L), pyrotechnic compositions and delay compositions. Whether an explosive reacts as a high explosive or a low explosive depends on the manner in which it is initiated and confined. For example, a double base propellant when initiated in the usual manner acts as a LE. However, this material can be made to detonate if it is initiated by an intense shock. Conversely, a HE like TNT, can, under certain conditions be ignited by flame and will burn without detonation (Ref 40a, p 97)

See also Deflagrating Explosives

Low-Explosive Train. Same as Propellant Train

LSt. Abbr for Lead Styphnate

Machine Gun. A weapon that fires small arms ammunition of caliber .60 or 15.24mm or under automatically and is capable of sustained rapid fire. It can be belt- or link-fed, air- or water-cooled, recoil or gas operated, and usually fired

from a mount. Cannons & Rifles are excluded from this definition [Ref: OrdTechTerm (1962), p 184 and Ref 45b, p 2-6]

Main Charge of a Detonator. Same as Base Charge

Main Charge of a Projectile. Same as Bursting Charge

MF. Abbr for Mercury Fulminate

Mine. An enclosed explosive or chemical charge designed to be placed in position so that it detonates when its target touches or moves near it, or when touched by remote control. General types are Land Mine and Underwater Mine. The term mine may also mean an explosive charge placed in a subterranean tunnel under a fortification (Ref 40a, pp 99 & 142)

Missile. Any object that is, or designed to be thrown, dropped, projected or propelled, for the purpose of making it strike a target (Ref 40a, p 102). See also Ballistic Missile and Guided Missile

Mortar. See Ref 44, p C27-R, under CANNON, and Ref 40a, p 102. In Ref 45f, p 2-1 it is defined as "a complete weapon conforming to the general cannon definition; including the attached or closely related units necessary for operation as intended (recoil mechanism, mount, sighting system, accessories, but not ammunition), and designed for performance characterized primarily by relatively long range, high velocity, and relatively little curvature of the projectile trajectory within the intended range"

MT. Mechanical Time Fuze

NC. Abbr for Nitrocellulose

NG. Abbr for Nitroglycerine

NGc. Abbr for Nitroglycol

NGu. Abbr for Nitroguanidine

Nitrocellulose (NC). See Cellulose Nitrate in Ref 44, p C100-L

NS. Abbr for Nitrostarch

Output Characteristics. The characteristics of an explosive component which determine the form and magnitude of the energy released when the component functions (Compare with Input Characteristics)

Payload. Generally that part of the load which is expandable, deliverable, or ready for use in direct accomplishment of the mission. In a projectile the explosive or other filler. In a guided missile or rocket, the warhead compartment and that which is carried in it (Ref 40a, p 108-L)

PD Fuze. Point-Detonating Fuze

PETN. Abbr for Pentaerythritol Tetranitrate

PI Fuze. Point-Initiated Fuze

Pistol. A short-barreled weapon held and fired with one hand, designed as an easily carried weapon for individual use. Current designs provide for rapid firing of 6 or more shots before reloading (Ref 45f, p 2-5)

Pistol (British). A mechanical device used since WWI, which is designed to initiate an explosive train by either freeing or functioning a striker but which contains no explosive itself. It is comparable in its mechanical function with US fuzes

Many types of pistols are described in conf TM 9-1985-1 (1952), which is available at Pic Arsn, but was not used as a source of information. More recent description is given in Air Ministry Pamphlet Nr 1667, classified "conf" in US and "restricted" in Gt Britain. A copy of pamphlet is in the Library of FSTC, 21st & Constitution Ave, Washington, DC (Refs 55 & 56)

Primacord. Trade name for Detonating Cord

Primary Explosive, also known as **Primary High Explosive.** An explosive which is extremely sensitive to heat and shock and is normally used to initiate a secondary high explosive. A primary explosive is capable of building up from a deflagration to detonation in an extremely short distance and time; it can also propagate a detonation wave in an extremely small diameter column. The term is generally used in referring to a pure compound and not to an explosive mixture. It has been suggested (Bowden & Yoffe) that primary explosives can be defined on the basis that upon slow heating they will decompose explosively while still in the solid state, while secondary HE's will melt before undergoing an explosive reaction. This characteristic is true for MF, LA, LSt & Tetracene, however, data are not available for all primary explosives. Some authorities claim that primary explosives do not belong to the class of high explosives but are an entirely separate entity (Ref 40a, p 111)

Primer (Commercial or Nonmilitary). See Section 1, Part B of this Vol

Primer (Military). See Section 3, Part D and Section 4, Part E

Primer Cap or Primer Cup A small metallic container, into which the primer mixture is loaded (Ref 40a, p 112)

Primer-Detonator. A unit in a metal housing which consists of a combination of a primer, a detonator, and, when indicated, an intervening delay charge (Ref 40a, p 112)

Primer-Igniter Mine Fuze. An item consisting of priming and initiating devices designed to initiate an antipersonnel mine (Ref 40a, p 112)

Primer Mixture. An explosive mixture containing a sensitive explosive and other ingredients used in primers (Ref 40a, p 112)

Priming Composition. A physical mixture of materials that is very sensitive to impact or percussion and, when so exploded, undergoes very rapid autocombustion. The products of such an explosion are hot gases and incandescent solid particles. Priming compositions are used for the ignition of primary explosives, BkPdr, igniter charges and propellants in small arms ammunition (Ref 40a, p 112) (See also in Section 3, Part D and Section 4, Part E)

Projectile. A missile for use in any type of gun. In a general sense the term is sometimes applied to rockets and guided missiles, although they may not fall within the stated definition. The term projectile is preferred over "shell", "shot", and the like, in official nomenclature (Ref 40a, p 113). Principal parts of projectiles and their types are described in Section 4, Part B of this Vol)

Propellant. A low explosive substance or mixture of substances, which thru burning can be made to produce gases at controlled rates and to provide the energy necessary to propel a projectile or missile. Propellants may be classified as liquid and solid propellants according to physical state. Liquid propellants, used primarily in rocket engines, may be classified as monopropellants, bipropellants, and sometimes multipropellants, according to the number of unmixed chemicals fed to the combustion chamber. Solid propellants, used primarily in gun type weapons and rocket motors, may be classified according to the number of basic explosives which they contain. A *single base* propellant contains only one explosive ingredient, such as NC. A common example of this is *pyro-propellant*. A *double-base propellant* (qv) contains two expl ingredients, commonly NC and NG. *Ballistite* (qv), the std proplnt used in US mortars is of this type. Cordite (qv), standard British proplnt is also double-base. There are also double-base proplnts contg NC & DEGDN or NC & TEGDN. These proplnts, known in US as "G" *Propellants*, were developed in Germany before WWII under the direction of Ger U. Gallwitz [See "G" Pulver in PATR 2510(1958), p Ger 70-R (Ref 35)]. There

are also *composite propellants* (qv) and *triple-base propellants*. The latter proplnts were first prepd in Germany in 1937 at the Dynamit AG by incorporating NGu in "G" Pulver, which means that these proplnts consisted of NC, DEGDN (or TEGDN) and NGu. The latter ingredient served as a cooling agent [See *Gudol-pulver* in PATR 2510, p Ger 81-L (Ref 35)]. The triple-base proplnts manufd in US consist of NC, NG & NGu as can be seen under CANNON PROPELLANT in Ref 44, Table V, p C34, Propellants M15, M17, T20, T29, M30 & M31

Propellent (or Low-Explosive) Train. Combination of primer, igniter and propellant used for propelling artillery ammunition. See Section 3, Part D

Proximity or VT (Variable Time) Fuze. See Section 5 of this Vol

Pyro, Pyrocellulose or Pyrocotton. A NC of ca 12.6% nitrogen content (Ref 44, p C103-L, under CELLULOSE NITRATE)

Pyrotechnic Devices. Items used for both military and nonmilitary purposes, such as producing bright lights for illumination, colored lights, or smoke for signalling purposes. These items are consumed in the process (Ref 40a, p 118 & Ref 43, p A384-R)

Pyroxylin or Collodion Cotton. Nitrocellulose of ca 12% N (Ref 44, p C103)

Quickmatch. Fast burning fuse made by impregnating cotton wick with mealed (finely powdered) or unmealed BkPdr. Gum arabic or dextrin is used as a binder. Quickmatch is highly sensitive to moisture and must be kept dry for proper functioning. It burns almost instantaneously when confined (Ref 23, pp 2-21 to 2-22 & USSpec JAN-Q-378)

RDX. Code name for Cyclonite, described as CYCLOTRIMETHYLENETRINITRAMINE (Ref 48, p C611-L)

Recoilless Gun or Recoilless Rifle. See Ref 44, p C28-R and Ref 23, p 2-5. Its ammunition is described in Section 4, Part B of this Vol

Relay. A component of a high-explosive train that provides the required energy to reliably initiate the next element in the train. Specifically applied to small charges that are initiated by a delay element and, in turn cause the functioning of a detonator (Ref 40a, p 120) (See also in this Volume, Section 4, Part F (Compare with Lead)

Relay Detonator. See Ref 23, pp 5-30 to 5-33 and also in this Volume, Section 4, Part F

Rifle. A shoulder-fired gun having a relatively long barrel with the bore helically grooved to impart a spinning motion to the projectile about its longitudinal axis, for improved stability in flight. The rifle is designed to obtain relatively high velocity, long range, and a high order of accuracy with projectiles of small diameter (Ref 45f, p 2-5) (See also Ref 40a, p 121)

Rocket. An unmanned self-propelled vehicle, with or without warhead, designed to travel above the surface of the earth and whose trajectory or course, while in flight, cannot be controlled. Excludes Guided Missiles and other vehicles whose trajectory or course, while in flight, can be controlled remotely (Ref 40a, p 122)

Rocket Engine. A non-airbreathing reaction propulsion device that consists essentially of an injector, thrust chamber(s) and exhaust nozzle(s), and utilizes liquid fuels and oxidizers at controlled rates from which hot gases are generated by combustion and expanded thru a nozzle(s) (Ref 40a, p 125)

Rocket Motor. A non-airbreathing reaction propulsion device that consists essentially of a thrust chamber(s) and exhaust nozzle(s) and carries its own solid oxidizer-fuel combination from which hot gases are generated by combustion and expanded thru a nozzle(s) (Ref 40a, p 125)

It is stated in Ref 40a, p 93, that the terms "JATO" and "JATO Unit" are discontinued as official names in favor of Rocket Motor or Rocket Engine. JATO is defined as a device, consisting of one or more continuous type combustion units closed at one end, with a nozzle type opening(s) at the other end containing a propelling charge which, when ignited, creates a gas pressure that is expelled thru the nozzle(s), exerting a propulsion action. The item is normally used to assist the initial action of the main propulsion unit(s)

Secondary High Explosive. A HE which is relatively insensitive to heat and shock and is usually initiated by a primary (high) explosive. It requires a relatively long distance and time to build up from deflagration to detonation and will not propagate in extremely small diameter columns. Secondary HE's are used for boosters and bursting charges. Sometimes called "noninitiating high explosives"

The terms "secondary high explosives" and "noninitiating high explosives" are not accepted by some authorities (Ref 40a, p 127)

Sensitivity. The characteristic of an explosive component which expresses its susceptibility to initiation by externally applied energy

Separated Ammunition. See Section 4, Part B in this Vol

Separate Loading Ammunition. See Vol 1 of Encycl p A385-L, under AMMUNITIONS AND WEAPONS

Service Ammunition. Ammunition intended for combat rather than for training purposes

Setback Force. The rearward force of inertia which is created by a forward acceleration of a projectile or missile during its launching phase. This force causes arming and eventual functioning of fuzes

Set Forward Force or Impact Force. The forward force of inertia which is created by the deceleration of a projectile, missile or bomb in flight or when impact occurs. It causes relative forward movement of some parts of am-

munition items and, in case of fuzes, its effect can be used to drive firing pins into primers or to drive primers against stationary firing pins

Shaped Charge (**Brit Hollow Charge**), also called **Cavity Charge**. An explosive charge with a shaped cavity to make possible the concentration of the explosive force in the desired direction. The localized explosive damage obtained by the shaped charge is known in US as Munroe Effect (Ref 23, pp 8-33 & G4)

It would be more appropriate to call it *Munroe-Neumann Effect*, because Neumann discovered it independently of Munroe and even proposed to apply the invention for military purposes (See Ref 51, pp 170-71)

Shell. 1) A hollow metal projectile designed to be projected from a gun. It can contain an explosive, chemical, atomic or other charge. The term projectile is preferred for that kind of shell 2) A cartridge for artillery or small arms or a shotgun shell. The term cartridge is preferred for this kind of shell (Ref 40a, p 129)

Shell Filler. See Bursting Charge

Shot. 1) A solid projectile for cannon, without a bursting charge 2) A mass or load of numerous, relatively small lead pellets used in a shotgun, as birdshot or buckshot (Ref 40a, p 130)

Shotgun. A short-range, shoulder fired gun, having a smooth bore suitable for expelling a group of pellets from a special cartridge (Ref 45b, p 2-5). Shotgun cartridge is described in Ref 44, p C73-L

Single Base Propellant. See under Propellants and in Ref 44, p C31-R under CANNON PROPELLANTS

Small Arms. They include guns with bore diameter not exceeding an arbitrary assigned limit which is, at present, 30mm (Ref 45f, p 2-5)

At the time of publication of Vol 1 of this Encycl (1960), the upper limit for small arms was 0.60 inch (Ref 43, p A383-R)

Smokeless Propellant. Term used to distinguish the relatively smokeless single-base, double-base and triple-base propellants from BkPdr which produces heavy smoke (Ref 40a, p 133) (See also CANNON PROPELLANTS in Ref 44, p C29-R)

Squib. 1) (General). Any of various small size pyrotechnic or explosive devices 2) (Specific). A small explosive device similar in appearance to a detonator, but loaded with low explosive, so that its output is primarily heat (flash). Usually electrically initiated, and provided to initiate action of burning type munitions, pyrotechnic devices and rocket propellants. An electrical squib consists essentially of a tube containing a flammable material, and a small charge of powder compressed around a fine resistance wire connected to electrical leads or terminals (Ref 40a, p 135)

Submachine Gun. A short-barreled, automatic gun using a larger, heavier bullet than the shoulder-fired rifle, but producing a relatively low projectile velocity effective only at short ranges. It employs a magazine of several times the capacity of the standard shoulder-fired rifle, and is used for rapid firing of a large number of projectiles against personnel at short ranges where high accuracy of fire is not essential (Ref 45f, p 2-6)

TEGDN. Abbr for Triethyleneglycol Dinitrate

Torpedo. A missile designed to contain an explosive charge and to be launched into water, where it is self-propelling and usually directable. Used against ships or other targets in the water. When designed for launching from aircraft, it is called *aerial torpedo*. There is also a *railroad signalling torpedo* which consists of an explosive device which can be attached to a railroad rail. When run over by a locomotive or car wheel, the resul-

ting explosion serves as a signal to alert the train crew (Ref 40a, pp 140-41)

Trench Mortar. See Ref 44, p C28-L

Triple-Base Propellant. See under Propellant in this Glossary

VT (Variable Time) Fuze. Same as Proximity Fuze

Warhead. That portion of a rocket, guided missile or torpedo designated to contain the load which the vehicle is to deliver. The load may consist of HE's, atomic bomb, chemicals, instruments or inert materials, as well as booster, fuze(s), adaption kits, and/or burster. Excludes items which contain atomic weapon components (Ref 40a, p 143)

Weapon. An instrument of combat, either offensive or defensive, used to destroy, injure, defeat or threaten an enemy, e.g.: a gun, a bayonet, a bomb, or missile [Glossary of Ordn (1959), 317]

Section 2, Part B Nomenclature Used by US Armed Forces for Ordnance Items

- A** suffix, denotes a standardized variation of a standard item, usually in design other than material (not applied to T numbers)
- AN** prefix, denotes a standardized item for use by both Army & Navy
- B** suffix, denotes a standardized variation of a standard item, denoting usually method of manuf or material
- E** suffix, denotes an experimental variation of either exptl or standardized item
- M** suffix, followed by number (such as M1, M2, etc), denotes an item standardized by Ordnance Dept
- MK or Mk** suffix, followed by number, denotes a standardized Navy item or old Army item
- Mod** suffix followed by number, denotes modification of a Navy item
- T** suffix, followed by number, denotes an

exptl item in process of development, and not standardized.

For example Fuze M52 can be modified to M52A1, M52B1, M52E1, M52A1B1, M52B1E1, etc, as explained by Chart (Ref 17, pp 11-12). See X

X like in XM, designates an experimental item. When the item is standardized, the X is dropped. The use of X & M together supercedes previous Ordnance Corps practice of designating experimental or test models by a single T

Section 2, Part C History of Development of Military Detonators, Igniters, Primers and of Other Initiating Devices

The first firearms (13th and 14th centuries) were heavy and could not be used as small arms. They were actually the predecessors of present cannons and their historical development was described in Ref 44, p C26, under CANNON. The first weapon which could be carried and fired by one soldier did not appear until about the 14th century. It was a short metallic tube of large diameter closed at one end and provided with a hole, called *touchhole*, drilled on the side of the tube near the closed end. The tube was mounted on a stick or rod which was held horizontally by a soldier under one of his arms, while the other arm was used for igniting thru the touchhole the PkPdr charge (serving as propellant) in the tube. As mentioned in Vol 2 of Encycl, p C73, in the early weapons loose BkPdr was poured from a container into the barrel thru the muzzle and this was followed by a wad and a lead ball serving as a bullet. For igniting the powder thru the touchhole, a match or a wick of cotton (or hemp) impregnated with saltpeter or lees of wine was used (See Fig). In order to make the ignition more effective, a shallow pan, called "priming pan", provided with a hole, was fitted over the touchhole and filled with a very finely ground BkPdr, called "pulverin". The pan could be covered to protect the powder from rain. When the match was later mounted on an S-shaped lever, called "cock", the device became known as *match-lock*. And when the

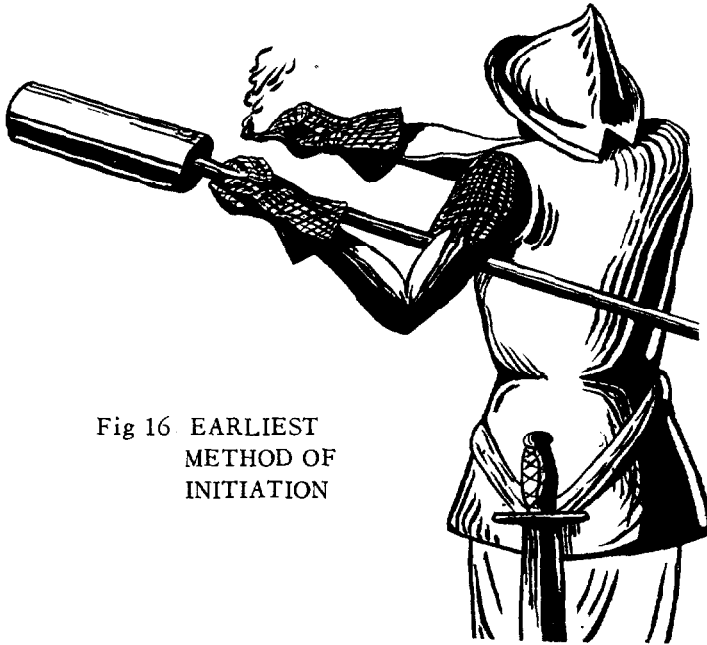

Fig 16 EARLIEST
METHOD OF
INITIATION

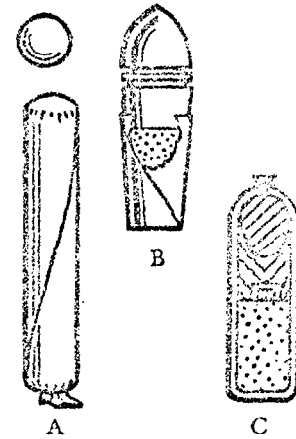

Fig 17 EARLIER TYPES OF
PAPER CARTRIDGES

stick was developed into a stock permitting to fire from shoulder, the firearm became known as *musket*, and the soldiers carrying it "musketeers"

The first mechanical action initiating device was the *wheel-lock*, which was a gunlock consisting of a serrated steel wheel (provided with a tension spring), a sear which fitted into a small hole in the side of the wheel, and a cock with a piece of pyrites attached. For firing the weapon, the spring was wound by a large key and the sear inserted in the hole to hold the wheel under tension. After loading the weapon thru the muzzle with loose BkPdr and bullet, as mentioned above, a small amount of pulverin was placed into the priming pan and the cock of wheel-lock was let down to allow the pyrites to touch the wheel. When the sear was withdrawn from the wheel by pressing a trigger, the wheel rotated rapidly and, because it rubbed against the pyrites, a shower of sparks was produced. This ignited the pulverin which communicated the fire to the BkPdr chge in the barrel. This type of lock was very heavy and as it was not always reliable, its use was rather limited

Although the development and use of wheel-lock continued until the middle of the 17th century, there was great need for a weapon

which would be lighter and more reliable in action. This need led to the development of a "gunlock" in which the fire was produced by striking two substances together, rather than by rubbing them. This type of lock was commonly known as *flintlock* or *firelock*

It should be noted that loose BkPdr charges were used until about the middle of the 16th century. Then the BkPdr was placed in a paper bag, as shown in Fig A, while the bullet remained to be loaded separately. The next step (ca 1590) was incorporation in the paper bag (cartridge) a wad or plug and a round bullet as shown in Fig C. Still later the bullet was elongated and pointed at the nose as shown on Fig B

A rather detailed view of the paper cartridge similar to that introduced in his Army by Gustavus Adolphus of Sweden (1594-1632) is shown in Fig 18

As mentioned in Vol 2, p C73 (Ref 44), none of the paper cartridges contained primers, as we know them now. Paper cartridges were not replaced by metallic cartridges until the beginning of the middle of 19th century. An ingenious proplnt chge, known as "Mammoth", was invented before Amer Civil War by General Rodman. In some cannons, it consisted of a single cylindrical piece of compressed BkPdr

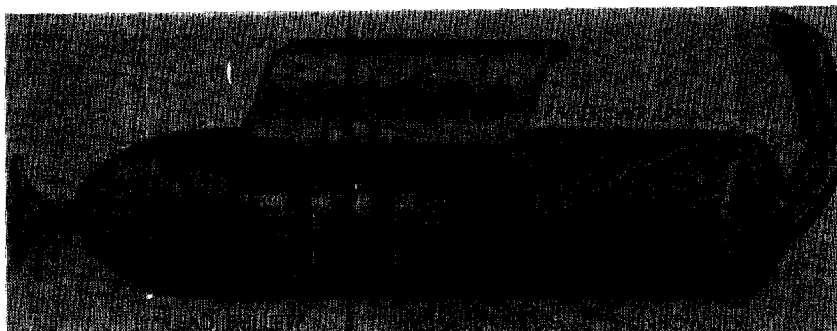

Fig 18 PAPER CARTRIDGE OF GUSTAVUS
ADOLPHUS OF SWEDEN

of nearly the same diam as the bore. In the center of cylinder was a perforation parallel to the axis. This proplnt was more or less progressive-burning. For some guns several cakes were arranged end to end with perforation forming a single channel (See Vol 2 of Encycl, p B167-L). A charge thus arranged is called a *stacked charge* in Ref 45f, p 5-6. It is one of the *noncased charges*

In the early type of flintlock, known as *snapshance*, the mechanism was constructed so that when the trigger was pulled, the flint struck against a sloping piece of iron, known as the "frizzen", causing a shower of sparks to strike the "pulverin" in the priming pan. With this type of gunlock, it was necessary to open the pan cover (thus exposing the powder to rain or fog) and to cock the hammer by hand before each firing

At some time near the 18th century the lock of "snapshance" was modified by combining the "frizzen" with pan cover into an assembly known as a "battery". This protected the powder from rain or fog and required only one motion, that of cocking the hammer, to make the piece ready to fire. When the trigger of the flintlock was pulled, the striking action of the flint against the "battery" opened it and at the same time directed the shower of sparks into the priming powder. The improved types of flintlock were used by the British until about 1850 and by the Americans as late as the end of the Civil War

The most important improvement in the initiation of BkPdr was, however, the development of the *percussion principle*, which was

made by the Scottish clergyman Alexander Forsyth. His patent, obt'd in 1807 in England, claimed the use of a loose, sensitive-to-percussion composition called "fulminating mixture". This mixt was placed into a small pan with a hole leading thru the touchhole to the BkPdr chge in the gun barrel. When struck with a falling hammer pressing the trigger of the gunlock, the fulminating mixt exploded, producing a flash which ignited BkPdr charge. As the handling of loose, sensitive fulminating material was inconvenient and dangerous, some later inventors tried to use that mixture in the form of pellets. Although this was an improvement, it was not as successful as when the fulminating powder was enclosed in a metal cap and then its open end was sealed to make the cap waterproof. The last invention was the prototype of present *percussion cap*. Accdg to Johnson, a recognized American authority on small arms and ammunition, the most probable inventors of the percussion cap were Joshua Shaw of Philadelphia and Joseph Manton of London. Although the cap was invented ca 1816, it did not come into nonmilitary use until 1825 and for military purposes until 1840-1842.

At first the cap was placed on a nipple, which was pierced with a hole communicating directly with the propelling charge of BkPdr, and the cap was struck with a hammer mounted above and behind it. Such cap was used at the time when no metallic cartridges were known

The historical development of cartridges from paper to metallic ones was briefly discussed in Vol 2 of Encycl, p C73-R (Ref 44)

under CARTRIDGE, AMMUNITION. To that description may be added that prior to invention of *center-fire* ammunition, the *rim-fire* cartridge appeared ca 1840 in the so-called *Flobert* ammunition. This cartridge was also used in early *Smith & Wesson* revolvers and in the Swiss repeating rifles of *Vetterli*. Rim-fire cartridges are still used in cal .22 ammunition. The French gunsmith Houiller, living at the time of Napoleon III, improved rim-fire cartridges and was one of the principal developers of center-fire cartridges. Although invented in the 1850's, the center-fire ammo remained practically unused until the time of the Amer Civil War. One of the 1st successful Amer center-fire cartridges was the so-called *Moore-Tit Cartridge*, invented in 1860's. It was loaded from the muzzle end of a revolver and fired by impact of the hammer on a "tit", filled with a fulminate, which protruded from the back of the round-based copper case. Other types invented in 1860's included *Thuer-* and *Folded-head cartridges*. The latter achieved some popularity in US and was used for about 20 years before being replaced in 1880's by a system which used primer cartridges representing refinements of *Boxer* and *Berdan* systems. These inventions were briefly discussed in Vol 2 of Encycl, p C73-R (Ref 44) (See also Refs 10, 10a & 46a)

It should be mentioned also that American General Berdan was an inventor (ca 1870) of a rifle which was not accepted by US Army, but was accepted by the Russian Govt. In its modified and simplified form it was used under the name of *Berdanka* as a service weapon until about 1891 and then for militia and training purposes (See Vol 2, p B101-R, Ref 44) (Also Ref 31, pp Rus 22 & 23)

Primers used in small arms and field artillery weapons were of the nonelectric type, but in stationary cannons, such as in coastal artillery or in Naval cannons, electric primers could be used

More extensive use of electric primers began in this century with the appearance of guns used in AC (aircraft), such as of cal 20mm. As firing by electric primers is much quicker than with mechanical primers (almost instan-

taneous), the weapons equipped with electric primers are "rapid-firing" [See TM 9-2205 (1952), p 29.

Accdg to P.B. Tweed, formerly of PicArnsn, Dover, NJ, (Ref 42b, p 653), who quotes from the article of Eichberg, published in July-Aug 1957 issue of Ordn (See Ref 33a), the earliest type of electric detonator for use in fuzes was devised in 1845-1846 by Lieut H. Moor, US Navy. He conducted experiments at Governors Island and Sandy Hook and as he could not obtain any funds from the Navy, a letter was sent to President Polk on Dec 31, 1845 with a description of the invention and request for funds. The letter apparently went unanswered and the funds were not provided. Nevertheless, Lieut Moor continued to work on his invention and conducted further experiments in April 1846. Being unable to obtain shells for his experiments, he employed a solid shot which was fired from a mortar using one ounce of BkPdr as propelling chge. The cartridge, contg a small expl chge and an electric detonator, was secured to the forward end of the shot. Two conducting insulated wires of 1500 ft each were connected to the detonator and made fast to the ring bolt of the shot. The wires were laid on the ground so as to run freely in order to maintain metallic communication between the shot and the point from which it was fired during the whole flight of the shot. The first shot that was fired fell at a distance of 674 ft, and just previous to its fall (when it had reached ca 500 ft from the mortar), the cartridge was exploded by an observer on the ground, by closing the electric circuit between the galvanic battery and wires. The flash and smoke produced on expln of the cartridge were distinctly visible from the ground. Subsequent examination of the fallen shot showed that expl contents of the cartridge were entirely consumed. Four more shots were fired with equal results before the insulation on the wire became defective. One additional shot was launched with a 2-ounce chge of BkPdr proplnt. It travelled 1050 ft and was exploded in the air at a distance, not specified. The wire used by Lieut Moor was No 26 copper, total wt of 1500 ft being 4 lbs. He wanted to continue experiments using lighter wires, such

as No 36 or No 40 steel wire, but abandoned the work altogether on being unable to secure funds from the Govt

Not only the above "air-burst", but "proximity-fuze" too, were envisioned by Lieut Moor. He proposed to equip shells and underwater mines (called in his time "torpedoes") with such fuzes. His proximity fuze was not described in the article of Eichberg (Ref 33a), but probably was in one of the official reports addressed to the Navy

Nearly a hundred years elapsed, after the invention of Lieut Moor, before interest in electric detonators was revived in USA. This was done during WWII when US Armed Forces began to fly electrical systems to perform fuzing and firing tasks. The first Army Ordnance Corps electric detonator, for use in fuzes, was the M36. It is described here in Section 5. It was used in proximity fuzes (VT fuzes) (Ref 42b, p 653)

It should be noted that electric firing devices for initiating propelling charges were used in "seacoast" and "railway" artillery before and during WWI (Ref 6, pp 227 & 314), but it does not seem that seacoast and railway artillery are used now by the US Armed Forces. The latest description of a seacoast primer was given in 1946 in the book by Ohart (Ref 17, p 53). The primer is M30

Electric firing devices have been used extensively in AA (antiaircraft) artillery since WWI, and even before

Section 3 DETONATORS, IGNITERS AND PRIMERS USED FOR INITIATING LOW EXPLOSIVES (INCLUDING PROPELLANTS) IN MILITARY AMMUNITION (EXCEPT IN FUZES)

Part A

Introduction

Initiation of a military explosive (or propellant) to deflagration, explosion or detonation can be achieved either by *ignition* or by *detonation*. *Ignition method* is used for producing *deflagration* (See Vol 3, p D38-R) (Ref 48), such as in case of propellants and some low demolition explosives, while *detonation method* (See in this Vol, p D137ff) is used for

initiating high-explosives, such in boosters, shells, mines, torpedoes, grenades, etc.

This section (3) confines to the description of devices used for initiating propellants in small arms and artillery ammunition, together with cutaway views of cartridges housing propellants. Cutaway views of typical mortar projectiles are also included, because their propellants are housed inside the projs and not separately as in other artillery ammunition. Other items for initiating low explosives such as firing devices for demolition explosives and land mines are also briefly described

Section 3, Part B

a) Definition of Ignition

The overall process of *ignition* involves heating a portion of a combustible such as an explosive, a propellant or a pyrotechnic composition, to its *ignition temperature*, which is the minimum temperature required for the initiation of a self-sustaining reaction. An ignition stimulus, which can be reduced to the effect of heat absorption, starts a sequence of preignition reactions, involving crystalline transitions, changes to liquid and gaseous phases, or thermal decomposition of one or more of the ingredients. The preignition period ends with the start of self-sustaining combustion. As the temperature rises, the rate of heat producing reactions will increase as predicted by the Arrhenius equation, which is written in Ref 54, p 32 as:

$$k = S \exp \left[\frac{-E_a}{RT} \right],$$

where k is specific rate constant; S - a constant; E_a - activation energy; R - gas constant and T - absolute temperature. The rate of heat loss will also increase with the temp, but because of exponential form of the Arrhenius equation, a temp may be attained at which the rate of heat generation is greater than the rate of heat loss and ignition will result

The *time to ignition* can be expressed by an equation similar in form to the Arrhenius equation. It is written in Ref 54, p 3-28 as:

$$t = A \exp \frac{E_a}{RT},$$

NOTE: All References are listed in Section 7, pp D1023 to D1055

where t is time to ignition and A - a constant, depending upon the material. Time to ignition is often measured by quickly immersing a small sample into a liquid, such as molten lead in a constant temp bath, and observing the temperature and the time from immersion to ignition. The calculated value E_a for the ignition process can be considered as a measure of the sensitivity of a substance to heat (Ref 54, p 3-28). See also "Burning and Combustion" in Vol 2 of Encycl, p B343-L (Ref 44) and "Combustion" in Vol 3, p C425-L (Ref 48)

Section 3, Part B

b) Prime Ignition

Accdg to AMCP 706-185 (1967) (Ref 54, p 5-45), prime ignition means starting of a fire without the use of another fire and includes methods based on friction, stab, percussion, concentration of the sun's rays by mirrors or lenses, and an electric impulse. Some materials or mixtures of materials can produce heat and burst into flame on exposure to air, as for example, white phosphorous or some metals which become pyrophoric when finely ground. Other materials burst into flame on contact with water or acid. Still other substances require only a small amount of energy to be ignited. The last group includes matches SAW ("strike-anywhere") and "safety". They are of importance as igniters of safety fuses and some pyrotechnic items. The SAW match has a small, easily ignitable (on any hard surface) *tip* composed of tetraphosphorus trisulfide (phosphorus sesquisulfide), P_4S_3 10, K chlorate 32, animal glue 11, rosin 4, neutralizer (ZnO) 6, powdered glass 33 & extender (starch, dextrin) 4%, affixed to a larger bulb serving as a base which is loaded with combustibles for strong billowing flame. The compn of SAW's base is: K chlorate 37, sulfur 6, rosin 6, dammar gum 3, phosphorus sesquisulfide 3, animal glue 12, extender 5, paraffin 2, infusorial earth 3, powdered glass 21.5, K dichromate (soluble burning rate catalyst) 1.5 & ZnO 1% (Compn adds to 101% as given in Ref 54, p 5-47). Ignition of the bulb causes ignition of paraffin impregnated wood splint to which it is affixed

A safety match requires for its ignition a rubbing on a "striking strip" which is covered with mixture such as consisting of red phosphorus 53, Sb sulfide 42 & charcoal 5% in a binder such as NC lacquer, animal glue, dextrin, casein, plus hardener. Sb sulfide and charcoal serve as extenders to the phosphorus. Sb sulfide also seems to fulfil the role of a neutralizer and preservative for phosphorus. The head of a safety match consists of K chlorate 45-55, animal (hide) glue (as a binder) 9-11, sulfur or rosin 3-5, extender (starch, dextrin) 2-3, neutralizer (ZnO or Ca carbonate) 45-55, infusorial earth 5-6 & other siliceous filler 15-32%. Fractional percentages of a soluble burning rate catalyst, such as K dichromate, also soluble dye stuffs, etc

The following match mixts used in friction primers for artillery are listed in Ref 54, p 5-48: 1) K chlorate 56.2, Sb sulfide 24.6, sulfur 9.0 & ground glass 10.2%; 2) K chlorate 44.6, Sb sulfide 44.6, sulfur 3.6, meal powder 3.6 & ground glass 3.6%. Ignition is effected by pulling thru pellets of above compns a loop of braided wire coated with red phosphorus in shellac (Ref 54, p 5-46) (See also Ref 37, p 6-R)

A friction primer compn for an airplane flare contains 14 parts K chlorate & 1.6 parts charcoal in 0.3 parts of binder (dextrin). Modified scratch sensitive mixts contg thermite produce very high temps and can ignite some smoke mixts without an intermediate starter (Ref 54, p 5-46)

In addition to matches and other scratch sensitive materials, prime ignition of pyrotechnic and other ordnance items can be achieved by stab, percussion or electrically ignited primer (or squib)

Certain chemical reactions can be used for prime ignition. For example, white phosphorus (which "self-ignites" when exposed to air) has been used in bursters for jelled gasoline incendiaries. Diethyl zinc or triethyl aluminum, contained in glass vial, has been used to ignite a match mix in a silent igniter. An alkali metal, Na, was proposed for a device designed to ignite oil slicks on water. This can be done because contact of Na with water results in evolution of hydrogen and enormous

heat sufficient to ignite hydrogen. The vigorous chem reaction resulting from bringing iron powder, K permanganate and sulfuric acid together is another example of prime ignition (Ref 54, p 5-46)

The compns used to ignite any burning type pyrotechnic should have the following characteristics: a) Be ignited by the primer, fuze, or match employed in the munition b) Ignite the main pyrotechnic compn c) Be sufficiently insensitive for safe handling in manufg and loading operations and d) Be resistant to the effects of moisture. The specific nature of the ignition compn is primarily detd by the particular ignition problem since it involves the nature of the filling to be ignited and the method by which the ignition compn is ignited. The wide variety of fillings used in burning-type munitions makes it impossible to develop one compn for all purposes

In general, ignition mixts may be classified as slag-producing or as gas-producing. As some compns produce both slag and gas, the type of filling to be ignited appears to be the most practical basis for differentiation of the various compns and they may be classified as follows:

- 1) Ignition compns for munitions contg thermite-type fillings or illumination compns, must produce high temp and not much gas
- 2) For munitions contg HC (hexachloroethane) smoke fillings, the reaction should be hot and preferably produce some slag, but only little gas
- 3) For munitions contg colored smoke mixts and toxic smoke mixts, the reaction product may vary from gaseous with slag to highly gaseous without slag

Ignition compns used as rocket motor igniters were usually ignited by the output of BkPdr, but now compn composed of a powdered metal and inorganic oxidizer is used (Ref 54, p 5-48)

The following definitions are given in Ref 37, pp 6-7:

- 1) *Friction Igniter* consists of a primer cup contg a mixt of K chlorate, charcoal and dextrin binder. A loop of wire coated with red phosphorus in shellac extends thru this cup
- 2) *Quickmatch*, which is used as an initiator to transmit flame to pyrotechnic chges, con-

sists of strands of cotton soaked in a mixt of BkPdr & gum arabic and coated over with mealed powder

3) *Priming Charge* is a dried paste of BkPdr in an intimate contact with *first fire composition*, which is generally a mechanical mixture of illuminating composition and BkPdr. Current new pyrotechnic items use a priming paste composed of a nonhygroscopic compn contg Ba nitrate, Zr hydride, silicon tetranitrocarbazole, and a plastic binder (Ref 37, pp 6 & 7)

4) *First-Fire Composition*. It is usually a mechanical mixture of an illuminating compn with BkPdr, as was defined under item 3. However, for certain items, it may be a special composition which is nonhygroscopic, easily ignitable mixture with high-burning temperature (Ref 37, p 6)

5) *Illuminating Composition* (Illuminant Charge) is defined in Ref 54, p 6-27 as a mixture of an oxidizing agent (such as Ba, K, Na or Sr nitrate) and a metallic fuel (such as Mg or Al). Other materials might include binders, waterproofing agents, burning rate modifiers, color intensifiers, etc. Compositions of several illuminant chges are given in Ref 54, Table 6-5, p 6-36, of which the following are examples:

- 1) Mg 26.9, Ba nitrate 38.3, K nitrate 25.2, linseed or castor oil 2.9 & wax paraffin 6.7% (White)
- 2) Mg 28.5, Al 6.5, Ba nitrate 57.0 & wax paraffin 8.0% (White)
- 3) Mg 36, Al 4, Ba nitrate 43, Na oxalate 12.5, oil 1 & wax paraffin 1.5% (White)
- 4) Mg 52, Na nitrate 35 & Thiocol 13% (Yellow)
- 5) Mg 58, Na nitrate 37 & Laminac 5%(Yellow)

Section 3, Part B

c) Ignition Train Used in Pyrotechnics

Since some pyrotechnic compositions are relatively difficult to ignite, an "ignition train" similar to that used for igniting BkPdr or smokeless propellants is used to initiate the main pyrotechnic charge

Accdg to Ref 37, pp 3 & 6, the ignition train for pyrotechnics begins with an initiator, usually a primer which may be of the percussion, friction, or electric type. The flame produced on initiation is transmitted successive-

ly to a propelling charge, delay element, expelling charge, and finally to the main charge of pyrotechnic composition (sometimes referred to as a "candle"). One or more intermediate elements between initiator and main charge may be absent depending upon the requirements of the pyrotechnic

Some delay charges are described in Vol 3 of Encycl (Ref 48), p D 50-L

Accdg to the description given in Ref 54, pp 5-45 to 5-49, the initiation of combustion of a pyrotechnic composition requires that a portion of composition be raised to its ignition temperature. Since some compns are relatively difficult to ignite, an explosive train similar to that used in other explosively loaded items is used to produce the ignition stimulus required to initiate the main pyrotechnic compn. Such a train can be considered as divided into three parts. The 1st part contains a sensitive initiating compn that can be initiated by a relatively small mechanical, electrical, or chemical stimulus. (See previous item, entitled "Prime Ignition"). This initiating compn produces on burning sufficient heat to initiate intermediate explosive or pyrotechnic compn(s) in the 2nd part of the explosive train. The output of this part will initiate the main charge in the 3rd part of the explosive train. In many cases a "delay train" (See Section 4, Part F, of this write-up) can be included in the 2nd part of an explosive train

Section 3, Part B

d) Primary Initiation, First Fires, Igniters and Starters Used in Pyrotechnics.

Accdg to Ellern (Ref 57, p 189), the terms "first fire" and "starter" refer in pyrotechnics not to the "prime ignition", but to the "intermediate ignition" source which is located between "primary initiation" and the "main pyrotechnic item", such as flares, signals, etc. The terms "starter mixture" and "ignition mixture" are sometimes used in the same sense. For ignition of intermediate mixtures, the so-called "primary initiation" methods are used. The simplest of these is to use the flame produced on striking either a "safety match" or "SAW" (strike-anywhere) match. Formulations

of these matches are given in Ref 44a, pp 270-72 and in Ref 57, pp 355-57. We are listing here in Table A only those safety matches which are recommended for special or military purposes, and in Table B are given compns of SAW matches. Table C gives compns of safety match strikers and Table D, a compn of waterproof coating of SAW matches

Table A
Safety Matches Suitable
for Military Purposes

| Components | Formulas: | | | |
|-----------------|-----------|----|----|-------|
| | % | 19 | 20 | 21 22 |
| K Chlorate | 60 | 50 | 88 | 45 |
| Sb Sulfide | - | 30 | - | - |
| Fe Oxide(red) | - | - | - | 5 |
| Charcoal | 6 | - | 10 | 3 |
| Wood Flour | - | - | - | 8 |
| Glass(powdered) | 22.5 | - | - | 39 |
| Dextrin | - | 20 | 2 | - |
| Gum Arabic | 11.5 | - | - | - |
| NC Solution | - | - | - | * |

* 100 parts of 22 mixed with 6.75 parts of NC (dry basis) in 25% soln

Table B
SAW Match Tip and Base
Compositions

| Components | Formulas: | |
|------------------|-----------|------|
| | 25 | 26 |
| K Chlorate | 32 | 37 |
| P Sesquisulfide | 10 | 3 |
| Zn Oxide | 6 | 1 |
| K Dichromate | - | 0.5 |
| Sulfur | - | 6 |
| Rosin | 4 | 6 |
| Dammar Gum | - | 3 |
| Animal Glue | 11 | 12 |
| Extender(Starch) | 4 | 5 |
| Paraffin | - | 2 |
| Infusorial Earth | - | 3 |
| Glass(powdered) | 33 | 21.5 |

Formula 25 is used for tip
Formula 26 is its base. It is loaded with combustibles for strong flame but is of low friction sensitivity

Table C
Safety Match Strikers

| Components | % | 27 | 28 | 29* |
|--------------------------------|----|------|------|-----|
| Red Phosphorus | 50 | 50 | 37.2 | |
| Sb Sulfide | - | - | 33.5 | |
| Fe ₃ O ₄ | - | - | 7.0 | |
| Mn Dioxide | - | - | 3.4 | |
| Ca Carbon ate | - | 5 | 2.0 | |
| Animal Glue | - | 16** | 9.3 | |
| Dextrin | 20 | - | 7.0 | |
| C Black | - | 4 | . | |
| Glass(powd) | - | 25 | 0.6 | |
| Sand(sharp) | 30 | - | - | |

* Taken from Shidlovskii's book

** Animal glue mixed with casein and hardener as given in USP 2722484 (1955) by I. Kowarsky

Table D
Waterproof Coating of
SAW Matches

| Components, % | Formula |
|---|------------|
| | <u>130</u> |
| NC(½ sec RS), as 25% soln ethyl acetate/butyl acetate(plus ethanol) | 70.0 |
| Cellulose acetate-butyrate, as 19% soln in acetone | 13.7 |
| Dibutyl Phthalate | 16.3 |
| Dye(soluble in organic solvents) | Optional |

Toluene/Isopropanol, added in 2:1 ratio to achieve ca 1000±200 cP viscosity in 20% solution

The flame produced on striking matches is used to ignite intermediate or "transfer" items of which *Safety Fuses*, also called *Bickford Fuses* (See Vol 1 of Encycl, p B112-L) are most frequently used. Blasters' Hdb (Ref 50, p 97) describes fuses with BT (burning time) 120 and 90 sec/yd. Requirements for safety fuses used for US military purposes are covered in Specification MIL-F-20412

Another simple device suitable to be ignited by ordinary matches is the *Quickmatch*, which consists of several cotton strands impregnated with BkPdr (See Vol 2 of Encycl, pp B165ff) in starch paste. It has a more-or-less well-defined burning time and thus acts as a delaying element, similar to safety fuse (Ref 57, p 191). Its military requirements are covered in MIL-Q-378B.

Quickmatch becomes a nearly instantaneous transfer line if enclosed in a narrow paper tube and is thus used under the name of *Piped Match* in fireworks for simultaneous initiation of several items (Ref 57, p 191)

The ignition with safety or SAW matches is inconvenient and not reliable when it must be done in the open, especially in windy or rainy weather. A high content of gas forming fuels and especially the added effect of phosphorus sesquisulfide (P₄S₃) make matches wind-resistant, and a match with a sizable amt of powdered charcoal will burn without flame but with strong glow. Such matches can be used for igniting safety fuses (Ref 57, p 72) but there are more reliable ignition devices, some of which will be listed here

Electric Matches, such as described in "Data Sheets" of Atlas Chemical Co, Wilmington, Del (1957) and in Ref 57, p 59, are small, resin-impregnated paper strips on which conductive brass strips are laminated with a wire loop affixed over one end. Two layers of "priming mixture" (Formula 12 of Ref 57, p 354: K chlorate 8.5, Pb Mononitroresorcinate 76.5 & NC (½-sec, dry base) are followed on the wire-loop by a chlorate/charcoal/lacquer mixt for flame and fire transfer. After applying a protective coating of clear lacquer, a bulb resembling a match tip results. Ignition is achieved by a current of 500mA for a minimum of 50msec. This is only one example of electric matches. There are others which use different currents and different match compns *M59 Electric Igniter* is a plastic molded button-shaped item used for igniting the propant expulsion chge in the M112 and M123 Photoflash Cartridges. A pyrotechnic mixture (Formula 13 of Ref 57, p 354: K chlorate 55 & Pb Thiocyanate 45%) is used in igniter. With the current 1.9A it fires in 50msecs (Ref 57, p 59)

M1A1 Squib, Mk/Mod O Squib and Mk3 Actuator discussed in Ref 57, p 59 are not included here, because they do not seem to be pyrotechnic items

Pull-Wire Fuse Lighter, which has the military designation:

M1 Friction Type Fuse Lighter, consists of a length of stiff paper tubing in which is inserted a metallic cup with a match compn, a length of fuse and a length of corrugated wire covered near one of its ends with a "striking" mixture and attached to a handle at the other end. The wire is threaded through a hole in the cup and on pulling the wire quickly by the handle, the contents of cup will be ignited and the fire transferred to the fuse train (Ref 57, pp 72-3). More complete description is given in Ref 31b

Portable Flame Thrower consists of small cup filled with "special purpose safety match composition": K chlorate 60, wood charcoal 6, gum arabic 11.5 & powdered glass 22.5% (listed as Formula 19 in Ref 57, p 355) and blunt pin coated with phosphorus mixt, such as P (red) 50, animal glue 16, powdered glass 25, Ca carbonate 5 & C black 4% (listed as Formula 28 in Ref 57, p 357). The pin is attached to a lever which makes the pin strike the inside of the cup. The resulting flame ignites a fuse, quickmatch, etc (Ref 57, p 73)

M1 Fire Starter, listed in Ref 57, p 73, is described in Ref 31b. Its match compn is formulated accdg to MIL-STD-585 (Formula 20 of Ref 57, p 361: K chlorate 50, Sb sulfide 30 & dextrin 20%) and the striker accdg to MIL-STD-537 (Formula 27 of Ref 57, p 356: Red P 50, dextrin 20 & sand with sharp edges 30%. A hot and relatively slow flame, affording transfer of the fire to the substratum into which the match button is embedded, can be obtd with formulation contg small amts of nonhydrophilic binders such as Formula 22 of Ref 57, p 355: K chlorate 45, wood flour 8, charcoal 3, Fe_2O_3 5 & powdered glass 39%, mixed with 25% NC soln in proportion 6.75 pts of dry NC per 100 pts of Formula 22. Formula 21: K chlorate 88, charcoal 10 & dextrin 2% is used if it is desired to obtain in M1 Fire Starter a series of sparks instead of solid flame after being hit by a phosphorus-coated striking pin

Self-Igniting Cigarette is a lighter based on the idea incorporated in the device "loco-foco" or "self-lighting segars" invented in 1835. Since then many improvements of this device were proposed, of which a recent one is that of F. DeCapitani, USP 3262456(1966) & CA 65, 13452(1966). These devices are briefly discussed in Ref 57, pp 71-2

Other devices for igniting fuse trains of pyrotechnic items are listed in Ref 44a, p 146, and described in Ref 50, pp 99-101 & Ref 57, pp 191-92 & 207-08. Some of the devices, besides the previously mentioned "safety fuse" and "quickmatch", include delay elements. *Lead Spitter Fuse Lighter* is a coil of thin lead tubing filled with BkPdr and wound on a reel. A desired length can be cut with a knife. It develops, on burning, a sharp tongue of flame and burns at the rate of 36ft/sec. The intense heat of the flame will ignite the end of safety fuse, making the slitting of fuse unnecessary (Ref 50, p 99)

Hot Wire Fuse Lighter consists of a wire covered with an ignition composition that burns slowly at a fairly steady rate with an intense heat. It is lighted with a match and then can be used to ignite safety fuse merely by holding the burning portion of the lighter against the freshly cut end of fuse (Ref 50, pp 99-100)

Safety Fuse Match Lighter is prepd by inserting one end of safety fuse into a short tube coated on the open end with a match mixture (Ref 44a, p 146)

Thermalite Ignitacord. It is mentioned in Ref 57, p 207 but not described. The cord burns with an external, short, very hot flame and comes in two types: 0.75 & 1.5 sec/in BT. It seems that it is the same as "Ignitacord", a cordlike device that burns progressively along its length with a very hot and short external flame, suitable for lighting a series of safety fuses in the desired rotation (Ref 50, p 100)

Pyrofuze consists of an Al wire or its braided strands clad with a layer of Pd metal. On heating to 660°C the two metals combine in very hot exothermic reaction, which progresses at 0.8-1.8 sec/ft depending on the type of wire. By winding the wire on a core

of low heat-conductive support, longer delay action can be effected, and lower time tolerances than for ordinary delays are claimed. It is described by Ellern (Ref 57, p 207) and in Pamphlets of Pyrofuze Corp, Mt Vernon, NY, 10553, manufacturers of device (Ref 49a). Pyrofuze is advertized in Ordnance 53, 248 (Nov-Dec 1968)

A new and different fire transfer and ignition is accomplished by means of line charges which contain relatively small amounts of expl chges. An example of such items is:

Pyrocore, manufd by DuPont Co. It consists of metal tubing 1/8 inch or less in diam filled with combined explosive and ignition mixture, 4-40 grains per foot. It is claimed that even coarse commercial Thermitite can be initiated from Pyrocore if Alclo Pellets (Al 35, K perchlorate 64 & vegetable oil 1%) are used as a starter or as a first fire (Ref 57, p 191 and "Explosives Specialty Manual"; E.I. duPont de Nemours, Wilmington, Delaware. (Not listed in alphabetical Index of Ref 50)

The oldest and still widely used in pyrotechnics and fireworks "first fire" and "starter" mixture is BkPdr. It belongs to mixts without metallic ingredients. Metallic mixts contain combustible powdered metals, such as Mg, Al, Zr etc. Metalloids B and Si are considered metallic fuels because of their similarity in pyrochemical behavior to metals. Although BkPdrs are described in Vol 2 of Encycl, pp B165ff, we are giving here as Table E compns of three formulations used in pyrotechnics, as described by Ellern (Ref 57, p 375)

Table E
Black Powders Used
in Pyrotechnics

| Components, % | Formulas | | |
|----------------------|----------|-----|-----|
| | 146 | 147 | 148 |
| K Nitrate | 74.0 | 70 | - |
| Na Nitrate | - | - | 72 |
| Charcoal | 15.6 | - | 16 |
| Coal(semibituminous) | - | 14 | - |
| Sulfur | 10.4 | 16 | 12 |

For glazing a small quantity of finely powdered graphite is added during finishing process

Bk Pdrs are safe to handle and are easily ignited over a wide range of temperatures, and at atm pressures as low as 0.1 atm. They also can serve as combined ejection and ignition materials (Ref 57, p 192)

Intermediate items, such as "first fires", "igniters", and "starters" are required because most of the "main" items (fuel-oxidizer combinations) are the least sensitive of all items. This is desirable from the point of safety in manuf and handling of larger quantities of expls as used in main items. The first fire, starter and especially prime igniter are, on the other hand, more hazardous and for this reason it is desirable to have them rather small. While it may seem advantageous to keep the number of components of a pyrotechnic system as small as possible, great discretion must be displayed when it is a question of omitting an intermediate charge in a chain of ignition. A prime igniter should not be increased in size in order to eliminate intermediate charges. The rule should be to keep the more hazardous mixts at minimum size. Transfer lines (such as fuses, quickmatch, etc) between prime ignition and first fire are regarded as a part of the secondary ignition system

When used with highly compacted main pyrotechnic items, such as "flare candles", the "first fire" is either pressed (in dry form), or painted (in paste or slurry form) on top of item. For initiation of solid proplnts, a "first fire" mixt can be ignited if confined in a tube or capsule so that the hot gases will be spread over a larger surface area (Ref 57, pp 189-91)

Table F lists various formulations for "starter mixtures"; Table G for "ignition mixtures" and Table H for "first fire mixtures". These formulations are given in Ref 57, pp 377-83. Some mixtures are taken from Ref 44a, pp 280-82

Formulas 161, 162 & 163 of Table F are of the same type as BkPdr. They are employed in a variety of items where extreme heat is neither needed nor desirable

It may be mentioned that the same mixtures that are employed as "first fires" (See Table H), may also have certain applications in "heat-producing cartridges" or "delay trains". Conversely, a "delay" or a "heat powder" mixture

can also be used as "ignition" or "first fire" mixtures. Furthermore, hazardous mixtures used in primers may be needed in special cases for fire transfer purposes (Ref 57, p 192)

soln in acetone. Both 166 & 167 develop high heat on burning and are suitable for HC smokes which are rather hard to ignite

Formulas 171 & 172, designated as "Ignition

Table F
Starter Mixtures

| Components, % | Formulas | | | | | | | |
|--|----------|------|------|------|------|------|--------|------|
| | 72 | 161 | 162 | 163 | 166 | 167 | 171 | 172 |
| Aluminum(powd) | - | - | - | - | - | 13.0 | - | - |
| Antimony(powd) | 35.0 | - | - | - | - | - | - | - |
| Ca Silicide | 35.0 | - | - | - | - | - | - | - |
| Charcoal | - | - | 6.0 | 29.5 | 6.0 | 4.0 | - | - |
| Cornstarch | - | 10.0 | - | - | - | - | - | - |
| CuO | - | - | - | - | - | - | - | 30.0 |
| Cu ₂ O | - | - | - | - | - | - | 33-1/3 | - |
| Fe ₂ O ₃ (Red) | - | - | 7.0 | - | - | - | - | - |
| Fe ₃ O ₄ (Black) | - | - | - | - | - | 22.0 | - | - |
| Glass(powd) | - | - | 31.0 | - | - | - | - | - |
| K Chlorate | - | 43.2 | - | - | - | - | - | - |
| K Nitrate | - | - | - | 70.5 | 54.0 | 35.0 | - | - |
| K Perchlorate | 30.0 | - | 49.0 | - | - | - | - | - |
| Na Bicarbonate | - | 30.0 | - | - | - | - | - | - |
| NC(added)(dry) | 5.0 | - | - | - | - | - | - | - |
| Pb Dioxide | - | - | - | - | - | - | 33-1/3 | 20.0 |
| Silicon | - | - | - | - | 40.0 | 26.0 | 33-1/3 | 50.0 |
| Sulfur | - | 16.8 | - | - | - | - | - | - |
| Wood Flour | - | - | 7.0 | - | - | - | - | - |

Remarks to Table F:

- Formula 72 is taken from Ref 44a, p 282. NC is added in soln as binder
- Formula 161 and other formulas are taken from Ref 57, pp 377ff. It is designated as "Starter Mixture VI" and its 60 parts are mixed with 40 parts of 4% NC soln in acetone
- Formula 162 "Starter Mixture" used by mixing 100pts with 37pts of 25% of 1/2-sec NC in ethyl acetate
- Formula 163 "Starter Mixture XII", used by mixing 50pts with 50pts of 4% NC soln in acetone
- Formula 166 "Starter Mixture V for Smokes", used by mixing 70pts with 30pts of 4% NC soln in acetone
- Formula 167 "Starter Mixture XXV for HC Smokes", used by mixing 83.3 parts with 16.7pts of 6% NC

Powder and Starter Compositions, are of "gasless" type. Of these 171, nicknamed by the Navy "six-six-six" is of unusual compn because it contains cuprous oxide as one of the oxidizers. It is used for igniting phosphorus candles in "Drift and Float Signals" contg: Red P 51, MnO₂ 35, Mg 8, ZnO 3 & linseed oil 3% (Formula 41 of Ref 57). Formula 172, which contains cupric oxide, is claimed to exceed the "six-six-six" in calorific output. It has been used by the Navy in the "Mk25Mod2 Starter Composition". Formula 172 was developed by W. Ripley at NAD (Naval Ammunition Depot), Crane, Indiana

[Reports AD 288746 (1963) and AD 439599 (1964)] (Quoted in Ref 57, pp 193 & 444)

In connection with the above formulas Dr Ellern (Ref 57, pp 193-94), remarks that an extremely potent, but seemingly very little known mixture, is the one consisting of flaked Al and powdered S in approx stoichiometric ratio of about one to two parts. It can be ignited with an ordinary match and reacts slowly producing a brilliant white glow and forming beads of Al sulfide. The glow is hot enough to initiate comps that are quite difficult to start, such as Thermite

Remarks to Table G:

Formulas 60, 68 & 69 are taken from Ref 44a, pp 280-81, where 60 is designated as "Gasless Ignition Mixture" and 68 & 69 as "Highly Sensitive Ignition Mixtures" which can also be initiated by electricity

Formulas 164, 165 etc are taken from Ref 57, pp 378-83

Formula 164, designated as "Ignition Mixture" is an unusual compn contg sugar. As a loose powder it is sealed in a plastic bag together with one end of a length of safety fuse. Some adhering, easily ignitable mixt is placed at the other end. The bag is placed among documents intended for destruction. Some nitrate is added to facilitate burning

Formula 165, developed by Dr Ellern as FIC-2 for the "Flare Ignition and Ejection Disk" is used with a binder of NC dissolved in butyl-acetate and methanol

Formulas 171 & 172, which are used as "Ignition and Starter Compositions", are listed on Table F

Formulas 173-176, designated as "Artillery Tracer Igniters"; also have Ordnance Corps designations, as indicated in Ref 57, p 381

Formulas 177 & 178 are used for "Thermitic Ignition"

Formula 179 is "Ignition Mixture III"; also known as Chemical Corps B2-50, or "Boom Powder". It is mixed with NC/Camphor soln and the slurry granulated

Formula 180 is a "Gasless Ignition Mixture" which can burn at very low pressure. Used with NC binder and powdered glass, it adheres to the item and its ash continues to adhere for efficient fire transfer

Formula 181, designated as "Ignition Mixture A1A"; is a rather violently burning, hazardous pdr of very high static sensitivity. Its ingredient "Superfloss" is a trade name for a finely ground calcined diatomaceous earth

Formula 182, known as "Ignition Pellet OS 9833a (Alclo) and Powder OS 9878" is used in pellet form. It was patented in Germany in 1963

Formula 183 is designated "Trichloral Rocket Ignition Mixture"

Formula 184, designated as "Rocket Igniter Pellet", contains "Lupersol" catalyst - 2% incorporated in Laminac

Remarks to Table H:

Formulas 64, 65, 66 & 67, designated as "Miscellaneous First Fires"; are taken from Ref 44a, p 280, while other formulas are from Ref 57, pp 379-80

Formula 168, designated as "First Fire for Illuminating Flares", contains binder Laminac 4110 or 4116 with 1.4% catalyst Lupersol DDM. Used in pressed-on form as the final igniting mixt in many illuminating flares and illuminating candles

Formula 169, designated as "First Fire X". Its component Celluloid (NC/Camphor) is used as 8-10% acetic soln to form a paste. Used in pressed-on form for igniting delay trains and also for Ther-

Table G
Ignition Mixtures

| Components, % | Formulas | | | | | | | | | | | | | | | | |
|--|----------|----|----|------|------|------|------|------|------|------|------|------|------|------|------|------|------|
| | 60 | 68 | 69 | 164 | 165 | 173 | 174 | 175 | 176 | 177 | 178 | 179 | 180 | 181 | 182 | 183 | 184 |
| Aluminum(powd) | - | - | - | - | - | - | - | - | - | 40.0 | - | - | - | - | 35.0 | 20.0 | - |
| Amn Dichromate | - | - | - | - | 10.5 | - | - | - | - | - | - | - | - | - | - | - | - |
| Asphal tum | - | - | - | - | - | 2.0 | - | - | - | - | - | - | - | - | - | - | - |
| Ba Chromate | - | - | - | - | - | - | - | - | - | - | - | - | 90.0 | - | - | - | - |
| Ba Peroxide | - | - | - | - | - | 78.0 | 80.5 | 4.0 | 79.0 | 31.0 | 91.0 | - | - | - | - | - | 23.7 |
| Boron(amorphous) | - | - | - | - | - | - | - | - | - | - | - | - | - | - | - | - | - |
| Ca Resinate | - | - | - | - | - | - | 2.0 | - | - | - | - | - | - | - | - | - | - |
| Charcoal | - | - | - | 6.0 | - | - | - | - | - | - | - | - | - | - | - | - | - |
| Diatomaceous Earth | 10 | - | - | - | - | - | - | - | - | - | - | - | - | - | - | - | - |
| (See also Superfloss) | | | | | | | | | | | | | | | | | |
| Fe ₂ O ₃ (Red) | 49 | - | - | - | 5.0 | - | - | - | - | - | - | 50.0 | - | 25.0 | - | - | - |
| Fe ₃ O ₄ (Black) | - | - | - | - | - | - | - | - | - | 29.0 | - | - | - | - | - | - | 70.7 |
| K Nitrate | - | - | - | - | - | - | - | - | - | - | - | - | - | - | - | - | - |
| K Perchlorate | - | - | - | - | 74.0 | - | - | - | - | - | - | - | - | - | 64.0 | 63.0 | 5.6 |
| Laminac | - | - | - | - | - | - | - | - | - | - | - | - | - | - | - | - | - |
| Magnesium(powd) | - | - | - | - | - | - | - | - | - | - | 9.0 | - | - | - | - | - | - |
| Na Nitrate | - | - | - | 47.0 | - | - | - | - | - | - | - | - | - | - | - | - | - |
| NC | - | - | - | - | 10.5 | - | - | - | - | - | - | - | - | - | - | - | - |
| Parlon(Chlorinated Rubber) | - | - | - | - | - | - | - | - | 5.6 | - | - | - | - | - | - | - | - |
| PbO ₂ | - | 80 | 60 | - | - | - | - | - | - | - | - | - | - | - | - | - | - |
| Pb ₃ O ₄ | - | - | - | - | - | 20.0 | 17.5 | 25.0 | 14.0 | - | - | - | - | - | - | - | - |
| Sr Peroxide | - | - | - | - | - | - | - | 70.0 | - | - | - | - | - | - | - | - | - |
| Sugar | - | - | - | 47.0 | - | - | - | - | - | - | - | - | - | - | - | - | - |
| Superfloss | - | - | - | - | - | - | - | - | - | - | - | 32.5 | - | 10.0 | - | - | - |
| Titanium | - | - | - | - | - | - | - | - | - | - | - | - | - | - | - | 13.0 | - |
| Toluidine Red Toner | - | - | - | - | - | - | - | - | 0.5 | - | - | - | - | - | - | - | - |
| Vegetable Oil | - | - | - | - | - | - | - | - | - | - | - | - | - | - | 1.0 | - | - |
| Vistanex (Polyiso-butylene) | - | - | - | - | - | - | - | - | - | - | - | - | - | - | - | 4.0 | - |
| Zinc Stearate | - | - | - | - | - | - | - | 1.0 | 0.9 | - | - | - | - | - | - | - | - |
| Zirconium | 41 | 20 | 40 | - | - | - | - | - | - | - | - | 17.5 | - | 65.0 | - | - | - |

Table H
First Fire Mixtures

| Components, % | Formulas | | | | | | |
|--------------------------------------|----------|------|------|------|------|----------------|------|
| | 64 | 65 | 66 | 67 | 168 | 169 | 170 |
| Ba Nitrate | - | - | - | - | 50.0 | - | - |
| Binder | - | - | - | - | 5.0 | - | - |
| Celluloid | - | - | - | - | - | 1.8 (added) | - |
| Fe ₂ O ₃ (Red) | - | - | - | 50.0 | - | 0.6 (added) | 25.0 |
| Pb ₃ O ₄ (Red) | 55.0 | 85.0 | 80.0 | - | - | 50.0 | 25.0 |
| Silicon | 33.0 | 15.0 | 20.0 | - | 20.0 | 25.0 | 25.0 |
| Tetranitrocarbazole | - | - | - | - | 10.0 | - | - |
| Titanium | 12.0 | - | - | 32.5 | - | 25.0 | 25.0 |
| Zirconium | - | - | - | 17.5 | - | - | - |
| Zr Hydride | - | - | - | - | 15.0 | - | - |

mates, for example, Formula 196 in Ref 57, p 386: Al (granulated) 16, Al (grained) 9, Fe₃O₄ 44, Ba Nitrate 29 & Sulfur 2%. In Formula 197, sulfur is replaced with 5% Laminac 4116, with catalyst added

The compositions of typical igniter, first fire, and starter mixtures are also given in Table 5-29, p 5-48 of Ref 54. This Table is reproduced here as Table I

Table I
First Fire, Starter, and Igniter Compositions

| Composition, % | A | B | C | D | E | F |
|-----------------------------------|----|----|----|----|----|----|
| Aluminum | — | — | — | — | — | 13 |
| Boron | — | — | — | 10 | — | — |
| Charcoal | — | — | — | — | — | 4 |
| Magnesium | — | — | — | — | 25 | — |
| Silicon | 20 | 25 | — | — | — | 26 |
| Titanium | — | 25 | — | — | — | — |
| Zirconium | — | — | 20 | — | — | — |
| Zr Hydride | 15 | — | — | — | — | — |
| Ba(NO ₃) ₂ | 50 | — | — | 90 | 75 | — |
| Fe ₃ O ₄ | — | 25 | — | — | — | — |
| Fe ₂ O ₃ | — | 25 | — | — | — | — |
| FeO | — | — | — | — | — | 22 |
| PbO | — | — | 80 | — | — | — |
| Pb ₃ O ₄ | — | — | — | — | — | 35 |
| Tetranitrocarbazole | 10 | — | — | — | — | — |
| Binder | 5* | ** | ** | ** | ** | ** |

* Laminac Binder (Laminac 99 & Lupersol 1%)

** NC lacquer or celluloid binder; can also be used as a loose powder

**Section 3, Part C
Military Igniters, Lighters
and Firing Devices**

An *igniter* can be defined as: 1) Any device, chemical, electrical, or mechanical used to ignite 2) Specially arranged charge of a ready-burning composition, usually BkPdr, used to assist in the initiation of a propelling charge and 3) Device containing a ready-burning composition used to amplify the initiation of a primer in the functioning of a fuze (Ref 40a, p 90). Description of groups 1 & 2 is given in this Section, while description of group 3 will be given in Section 4

Section 3, Part C

a) Igniters for Fuses Used in Ordnance Items

These igniters, known also as *lighters*, are used for igniting "safety fuses". Some are known in the US as "Bickford Fuses" (See Vol 3 of Encycl, p B112-L) and serve to initiate certain demolition explosives (See Vol 3 of Encycl, p D56-R)

- Following are examples of fuse igniters:
- 1) *Time Blasting Fuse Igniter M1 (Friction Type)* (Fig 19), consists of a paper tube which contains a wire coated with red phosphorus and a friction composition (such as consisting of K chlorate, charcoal and dextrin). The fuse (to be ignited) is inserted thru the open end of the tube and is held in place by an insert with inclined prongs (fuse retainer). A pull on the wire at the closed end ignites the friction pdr which in turn fires the fuse
 - 2) *Time Blasting Fuse Igniter M2 (Weatherproof)* (Fig 20) consists of a tube that holds at one end the firing mechanism, while at the other end (base) is placed a percussion primer and a pronged fuse retainer. When the release pin is pulled, the striker hits the primer and this will cause the ignition of its contents and the ignition of fuse
 - 3) *Time Blasting Fuse Igniter M60 (T2), (Weatherproof)* (Fig 21), consists of cylindrical housing with a threaded top cap at one end and a striking mechanism. At the other end

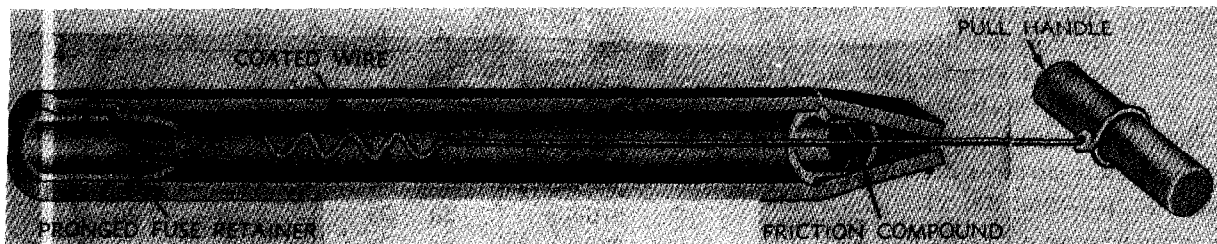

Fig 19 TIME BLASTING FUSE IGNITER M1 (Friction Type)

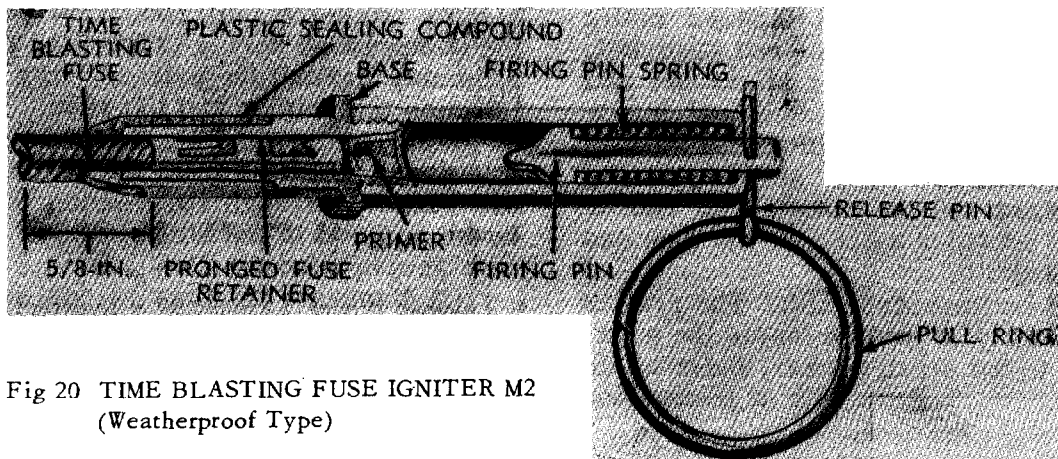

Fig 20 TIME BLASTING FUSE IGNITER M2 (Weatherproof Type)

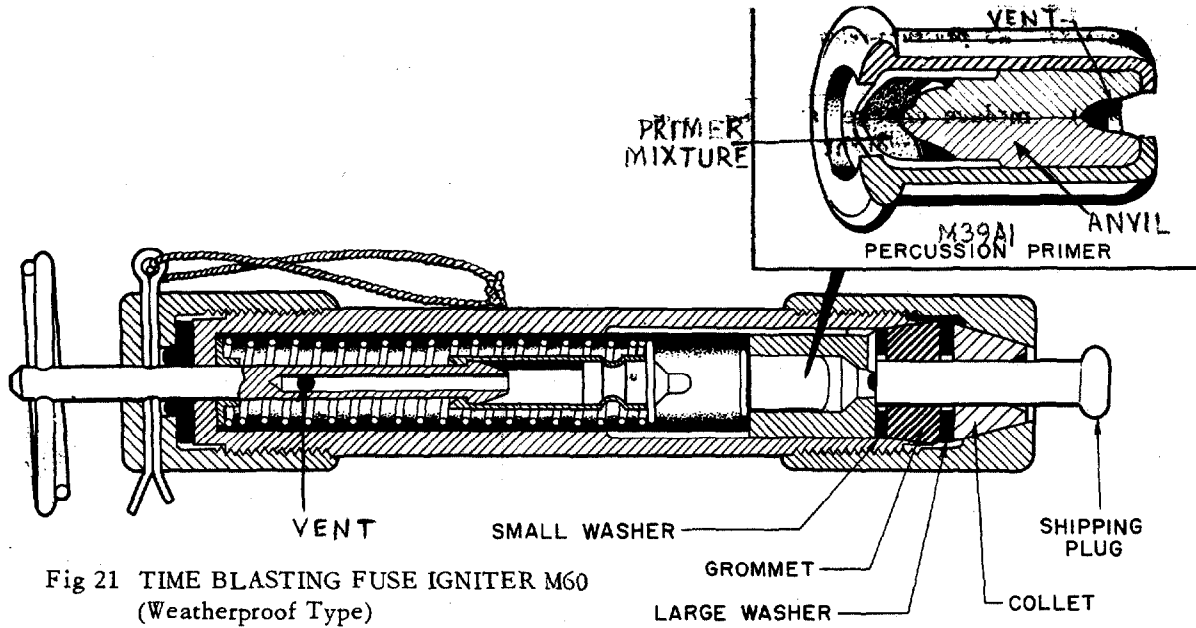

Fig 21 TIME BLASTING FUSE IGNITER M60 (Weatherproof Type)

of the housing is located the percussion primer M39A1 and time blasting fuse M700. The fuse is inserted after removing the shipping plug. The pull rod of striking mechanism has a vent which allows the fuse gases to be released to the atmosphere after firing. The vent is opened to the atm only when the rod is in the "firing" position and therefore does not affect the weatherproof feature of the igniter (Ref 30a, pp 54-5; Ref 46, pp 45-50 and Ref 53, p 45)

Section 3, Part C

b) Firing Devices

A firing device is designed to initiate a train of fire or detonation in demolition charges, boobytraps, or mines, principally by action on

a nonelectric blasting cap or activator (See in Glossary). They are of two general types, the tubular - and the box type. The *tubular type* devices, consisting of head, case, and coupling base, are arranged for actuation by pressure, pull, or release of pull. The *box-type* devices, consisting of a rectangular steel body and coupling base, are arranged for release of pressure. The coupling base, fitted to all types, contains a percussion primer

Following are examples of "firing devices":

1) *Delay Type Firing Device M1 (Demolition)* (Fig 22) consists of a two-part cylindrical case, joined near the center by a coupling. The half of the case which contains firing mechanism is brass, while the other half contg glass am-

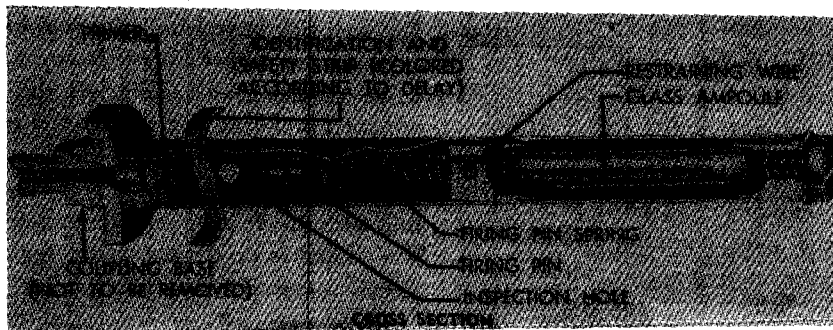

Fig 22 DELAY TYPE FIRING DEVICE M1

poule with corrosive liquid, is thin copper capable of being crushed between thumb and finger (See Fig 22). When the ampoule is broken, the released corrosive liquid eats thru the restraining wire, thus allowing the firing pin to strike the primer in the coupling base

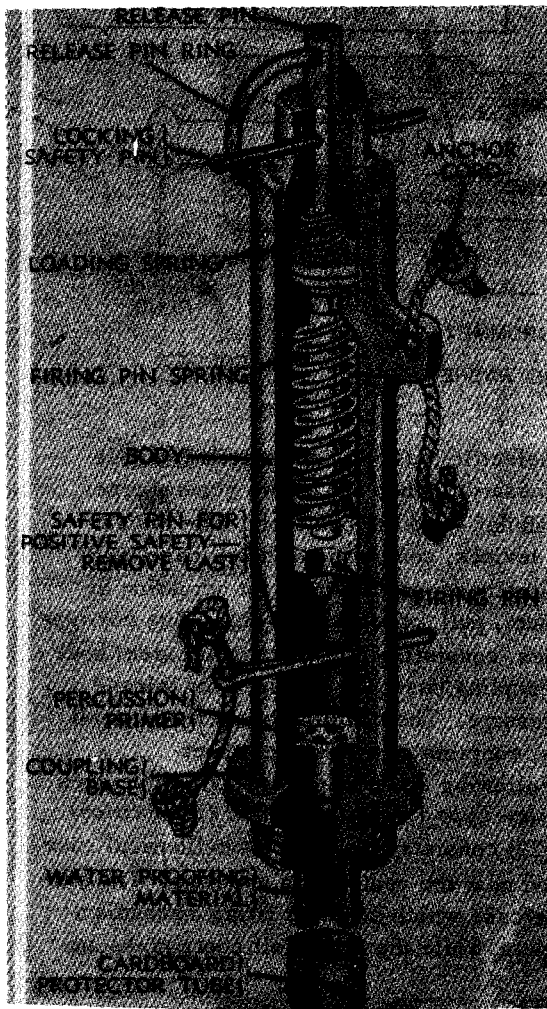

Fig 23 PULL TYPE FIRING DEVICE M1

2) *Pull Type Firing Device M1 (Demolition)*, (Fig 23), consists of a cylindrical case, head and coupling base. The head, which is permanently joined to the case, contains a release pin, release pin ring, a loading spring, and a safety pin. The case, which contains the firing mechanism, consisting of a firing and compression spring, also contains a positive

safety pin which is removed last. The coupling base, which screws into the case, contains the primer. The outer end of the coupling base is threaded to fit activators and firing device wells (cap wells). It has a nipple to which a blasting cap may be assembled. A direct pull of 3 to 5 lbs on the trip wire of an antipersonnel mine or a boobytrapping antitank mine, causes the release pin to be pulled outward, overcoming the resistance of the loaded release pin spring. The slotted end of the firing pin, being no longer restrained by the cylindrical opening, passes thru the opening. The released firing pin, driven by the compression spring then fires the percussion cap

3) *Release Type Firing Device M1 (Demolition)*, (Fig 24), is designed to be actuated when a restraining weight, (usually greater than 3 lbs), is removed from it and is intended for use in setting boobytraps. The firing mechanism is cube-shaped, ca 2 inches square and 3 inches long. It is fitted with a cover at one end and a threaded hole to receive a primed coupling base at the opposite end. Upon removal of restraining weight from the latch, the spring lever is released and is driven thru an arc of ca 75 degrees to strike the firing pin, which explodes the primer in the coupling base

4) *Pressure Type Firing Device M1A1 (Demolition)*(Fig 25), is intended for use in mines and boobytraps. The device consists of a trigger head, a case, and coupling base. Its head contains the firing pin release pin mechanism which terminates in a pressure cap. The case contains the firing mechanism, consisting of a spring-loaded firing pin held in the "cocked" position by a firing pin release pin, which is attached to the pressure cap. The coupling base which screws into the case contains the primer. A pressure of 20 pounds on the trigger head compresses the firing pin, release pin spring and pushes the release pin inward. When the enlarged portion of the key-hole-shaped opening in the release pin is in line with the spindle, the firing pin is released and is driven by spring against the percussion primer thus firing it

5) *Pull-Friction Type Firing Device M2 (Demolition)* (Fig 26) is designed for actuation by a pull wire and intended for use in setting

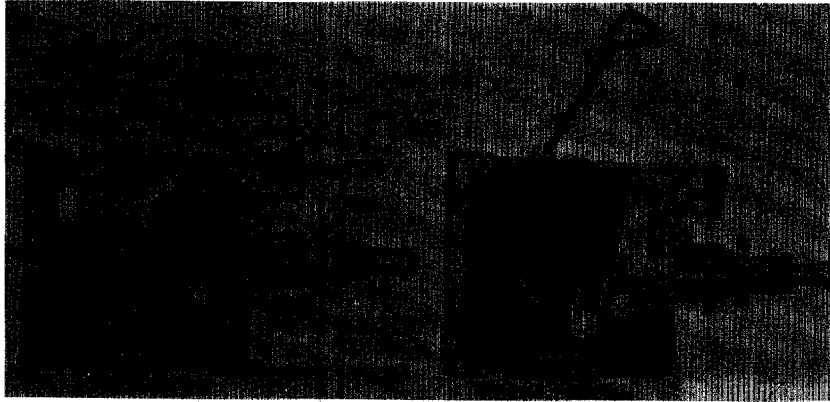

Fig 24 RELEASE TYPE FIRING DEVICE M1

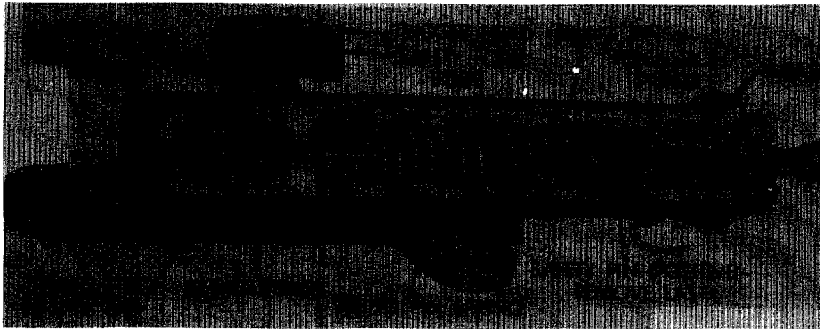

Fig 25 PRESSURE TYPE FIRING DEVICE M1A1

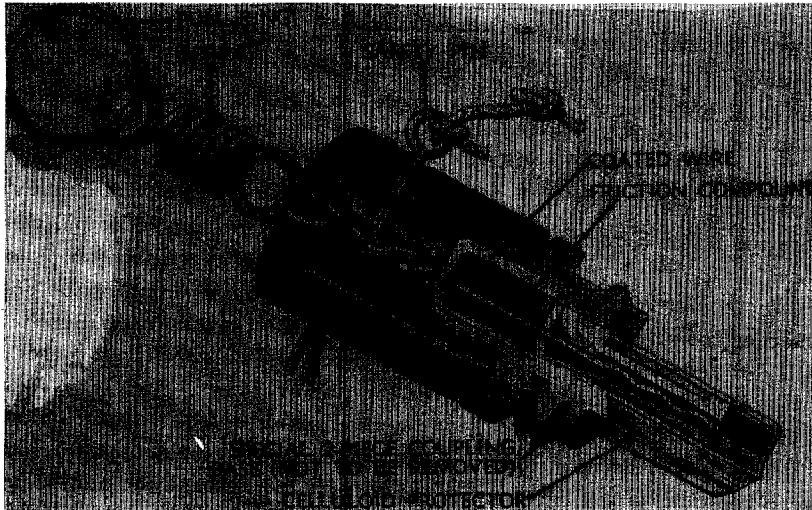

Fig 26 PULL-FRICTION TYPE FIRING
DEVICE M2

up boobytraps. The device consists of a body, a nonremovable base, and an assembly consisting of a pull ring, a spring, and a coated wire secured by a safety pin. The

nipple on the base is fitted with a celluloid protector, which contains a dessicant to keep the friction compd dry. The outer end of the base is threaded to fit activators and

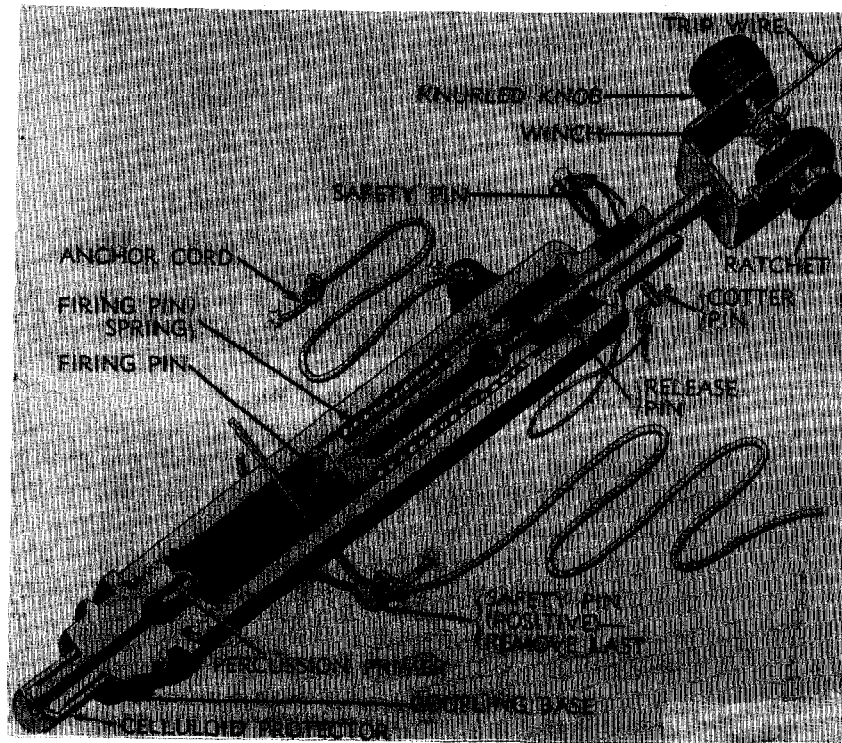

Fig 27 PULL-RELEASE TYPE FIRING
DEVICE M3

firing device wells (cap wells). The coated wire, to which the spring and pull ring is attached, passes thru the axial hole in the body, then thru the friction compd, and into the nipple. A direct pull of 3 to 9 pounds on the trip (pull) wire stretches the spring and draws the coated wire thru the friction compd, thereby igniting it

6) *Pull-Release Type Firing Device M3 (Demolition)* (Fig 27), is designed for actuation by either an increase (pull) or decrease (release) of the tension in the taut trip wire and is intended for use with antipersonnel mine M3, improvised antitank mines and in setting up boobytraps. The device consists of a head, body, coupling base, firing pin, release pin, safety pin and winch assembly. The head, which is crimped to the body, acts as a guide for the release pin. The body contains a spring-loaded firing pin in which the knob end of the release pin is installed. The coupling base which screws into the body, contains the primer. The outer end of the

coupling base is threaded to fit activators and firing device wells (cap wells) and has a nipple, to which a blasting cap may be assembled

In the *pull operation*, a direct pull of 6 to 10 pounds on the trip wire causes the release pin and firing pin to be pulled outward until the jaw end of the firing pin passes beyond the constricted opening of the body. In this position, the jaws spread, thereby releasing the firing pin which, driven by its spring, fires the primer

In the *tension-release operation*, release of tension, such as cutting or detaching trip wire, permits the release pin and spring-loaded firing pin to move inward. When the end of the firing pin clears the constricted opening in the body, the jaws spread, thereby freeing the firing pin (from the release pin) to strike the primer

7) *Pressure-Release Type Firing Device M5 (Demolition)* (Fig 28) has been used to activate antitank mines equipped with supplement-

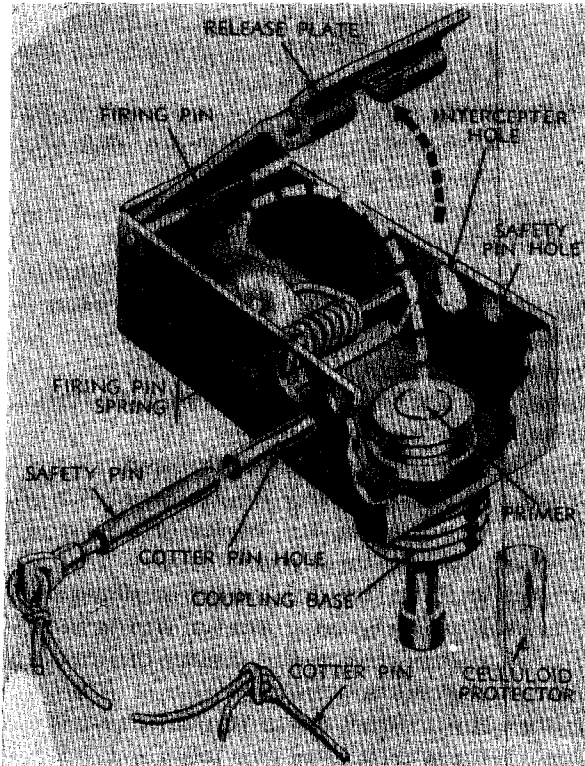

Fig 28 PRESSURE-RELEASE TYPE
FIRING DEVICE M5

tary fuze wells (cap wells) and for boobytrap installations with charges having threaded wells. The device consists of a rectangular pressed steel case contg a spring-loaded striker. The striker is restrained by a release plate, which is held in place by a safety pin. A coupling base fits into the threaded hole in the bottom of the case. When restraining load of at least 5 pounds is displaced more than $\frac{5}{8}$ of an inch, the release plate frees the firing pin which, being under the strain of the spring, strikes the primer (Ref 30a, pp 58-81; Ref 46, pp 54-70; and Ref 53, pp 40-5)

Section 3, Part C

c) Ram-Jet Engine Igniter

The Igniter, M114, 45-Second, formerly known as Igniting Flare, M114, 45-Second, is used to ignite the fuel-air mixture in a ram-jet engine. The igniter contains a pyrotechnic compn which, when ignited, generates sufficient heat to maintain burning of the fuel-air mixt for 45 secs, after which the engine becomes self-igniting. The device consists of a boxboard tube 8.25 in long by 2 in diam which encloses in addn to engine igniting charge, a first-fire chge, a priming chge, a quickmatch and two electric squibs. Leading wires extend thru a boxboard cover at the initiating end of the case. The cover is secured in place by adhesive tape. The other end of the case is closed by a chipboard disk cemented in place. The two squibs are wired in parallel, so that a failure of one would not prevent proper functioning of the item. As issued, the two ends of the leading wires which protrude thru one end of the case are twisted together to short the electric circuit. This prevents accidental functioning due to any stray electrical currents during storage or shipment. When the igniter is installed in a ram-jet engine, the two leading wires are untwisted and connected to leads from the electrical source. When the circuit is closed, the squib ignites the quickmatch igniter. The closing cover is blown off as the fire is transmitted, in turn, thru priming chge and first-fire chge to the main pyrotechnic chge which ignites and maintains ignition of the fuel-air mixt in the ram-jet engine for 45 secs (Ref 37, pp 121-22, Fig 60) (Our Fig 29)

A similar device, the Ram-Jet Engine Igniter M132 (T123) (90 sec) (formerly FLARE, Igniting M132), is described on pp 122-23, Fig 61 of Ref 37

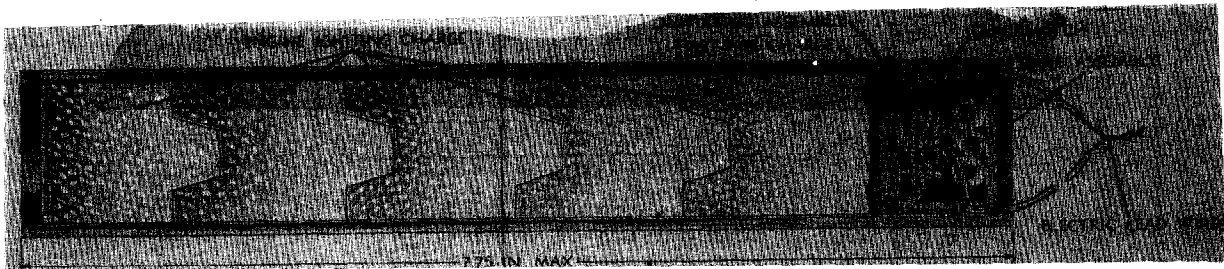

Fig 29 RAM-JET ENGINE IGNITER M114
(45-Second)

Section 3, Part C

d) Igniter Compositions for Tracers (ICT)

Igniter compns used in conjunction with tracer compns (TC) are designed to have much lower ignition temps and produce very little gas. This latter feature makes them much less luminous than the TC's. If practically no luminosity is developed the compn is known as a "dim igniter composition"

Following are some ICT's used in US for igniting Standard Red Tracer M2, which consists of Mg (coated with 1.5% linseed oil) 22.7, Sr nitrate 45.5 & asphaltum 9.1%:

1) ICT "K" - Mg 20, Ba oxide 78 & asphaltum 2% 2) ICT I-181-Mg 12, Ba oxide 86, Zn stearate & Red toner 1%

The compn of a "dim igniter" is Mn 32.5, Pb chromate 50 & sulfur 17.5% (Ref 30, p 293)

Fig 30 shows the location of igniter compn in relation to tracer compn in APT shell as described in Ref 54, p 6-3

Section 3, Part C

e) Igniter Compositions for Pyrotechnic Items

are described in Section 3, Part B under item c

Section 3, Part D

Military Primers

(Except in Fuzes)

a) Definition of Term Primer

A *primer*, in general can be defined as an explosive item which occupies the initial position in the explosive or propellant train. It contains a relatively small amount of one or several compounds which are very sensitive to impact, heat, or friction. These substances are known as *primary compounds* or *priming compositions* and might include MF (usually in mixtures with K chlorate and a powdered abrasive), LA, LSt, Tetracene, etc. These substances undergo on initiation very rapid decomposition producing very hot gases and incandescent solid particles. Primers can be used for initiating by flame *igniter compositions* (such as BkPdr igniters) and also small-grain smokeless propellants (such as used in small arms). Primer, by itself, cannot initiate HE charges, but can do it with the help of a *detonator* and *booster* as it will be further explained. Primers exist in various forms and types and are generally classified in accordance with the method of initiation as percussion, stab, electric, friction and combination electric-percussion. Primers which are used for initiating propellants may be sub-

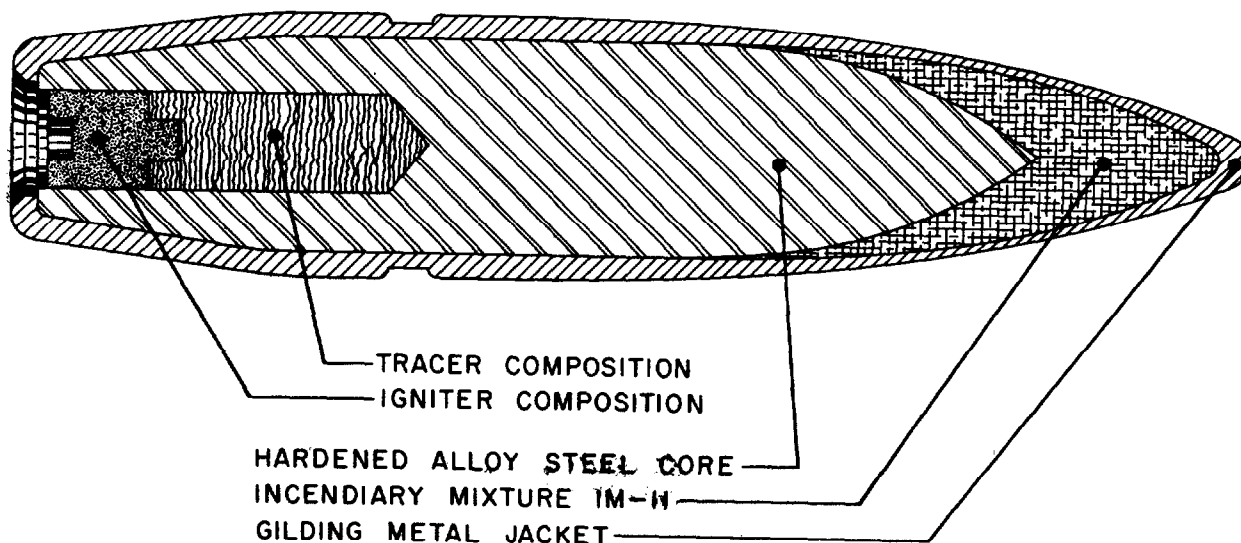

Fig 30 IGNITER COMPOSITION IN ARMOR-PIERCING-TRACER SHELL

divided into "simple primers" and "combination primers"; known as "primer-igniters"

Simple Primers consist of a housing (brass or copper cup) containing a primary mixture and parts, such as an anvil, or electrical bridge. They are used for igniting small arms projectiles by flash. For their description and cutaway views see next item (b)

Combination Primers, known as *primer-igniters*, combine a "simple primer" with an "igniter"; known as "propellant igniter". Igniters are required not only because the artillery projectile charges are large, but also because these projectiles are harder to ignite since they are of larger granulation than projectiles used in small arms. The requirement to employ primer-igniters applies only to ammunition 37-mm or larger but is not required for cannons of 20-mm or smaller. Such weapons can use percussion-primer M36A1 alone (See Fig 50 in this Section) The function of a "propellant igniter" may be compared to that of a "booster" (See Ref 44, p B243-R) used in HE trains of projectiles or bombs

Description of primer-igniters is given under item (c) in Section 3, Part D

Section 3, Part D

b) Small Arms Primers or Simple Primers

These primers can be used not only in small arms but also in some pyrotechnic devices and fuzes. All simple primers are small in size, 0.21 to 0.31 inch in diam and 0.12 to 0.23 inches long for rifle ammunition and slightly smaller for carbines. They contain only one small charge of primary expl or a mixture which must have sufficient sensitivity to be initiated either by the crushing or stab action of a firing pin

Percussion primers used in current *center-fire cartridges* (See Ref 44, p C74-L) in US and NATO small arms are shown on Fig 31 is taken from TM 9-1305-200 (1961), p 25 (Ref 42). Each of these primers consists of a small brass or gilding metal cup that contains a primer compound pellet. Present compounds are mostly noncorrosive type, such as consisting of LSt-LA. The older types contained usually MF, $KClO_3$ & Sb_2S_3 , with or w/o ground glass and a binder. A paper disk (foil), which serves

to hold the pellet in place and to protect it from moisture and electrolytic action, is inserted next. This is followed with insertion of a brass anvil. A blow from the firing pin of a gun on the center of the primer cup compresses the primer pellet violently between the cup and the anvil, thus causing an explosion with evolution of hot flame. The vents in the anvil allow the flame to pass from the cup into cartridge case, thereby igniting the projectile. A small-arms primer will not initiate, by itself, an explosion (Ref 42, p 24)

Since in the anvil-type of primer the cup is not pierced, obturation (sealing) is obtained after the primer is fired, because the entire cup is pressed into cartridge cavity. Such primers are also known as *obturated type*, to distinguish them from the *unobturated type*, which is usually employed as an "explosive-train element" in fuzes. This type and some obturated types employed in fuzes are described in Ref 4, Part F

The complete round (cartridge) of small arms ammunition (except for the shotgun), employing one of the center-fire obturated type primers is represented in Fig 32

In the *rimfire ammunition*, such as caliber .22 cartridge there is no primer assembly as described above, but the primer compound is spun into the rim of the cartridge case and the projectile is in intimate contact with the compound. In firing, the firing pin strikes the rim of the case and thus compresses the primer compound and initiates its explosion [See top left Fig on p C74-L of Vol 2 of Encycl (Ref 44) and Ref 42, pp 24-5 & Ref 45f, p 5-6]

Section 3, Part D

c.) Artillery Propellant Primers or Primer-Igniter.

(Brief Description)

To the definition given under item (a), may be added that propellant igniters consist of a charge of quick-burning BkPdr (See BLACK POWDER in Ref 44, p B171), which can be either in the form of a compressed disc attached to a "simple" primer or in the form of small grains contained in a perforated tube. In a 3rd method, loose BkPdr is contained in a small cloth bag which is placed, during

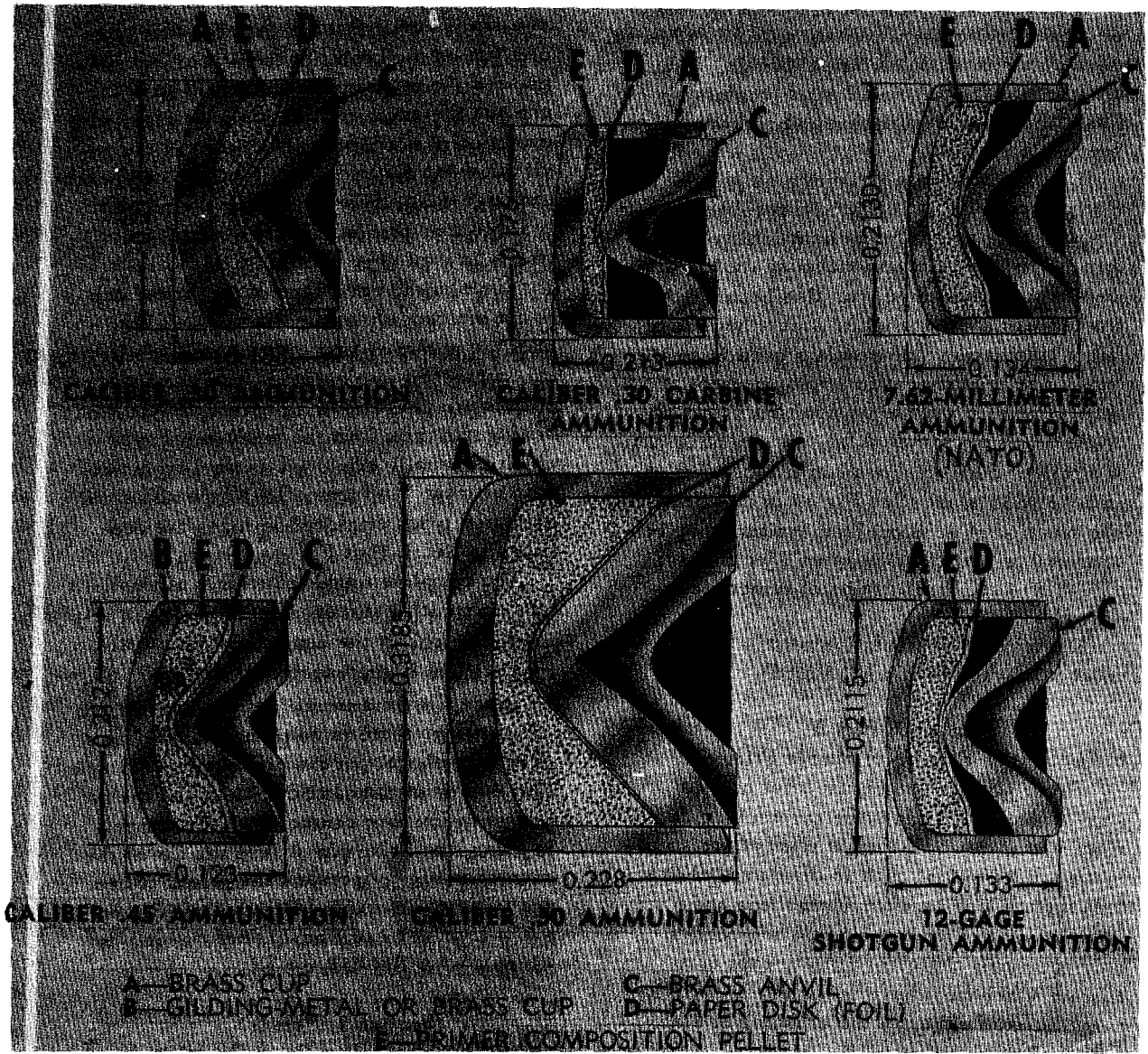

Fig 31 PERCUSSION PRIMERS FOR SMALL ARMS AMMUNITION

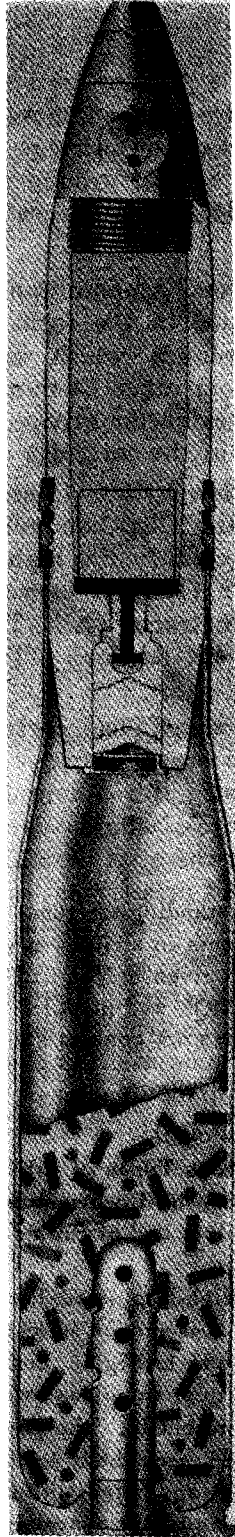

Fig 33 37-mm HE-T, SD FIXED AMMUNITION
M54A1 FOR AUTOMATIC GUNS

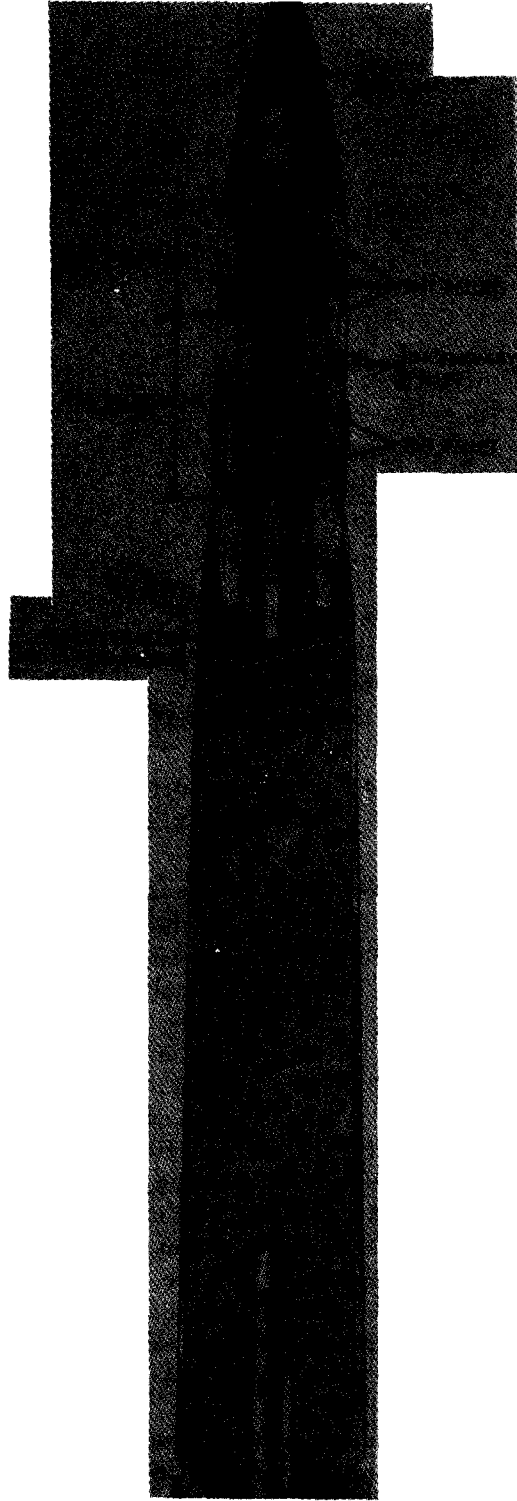

Fig 34 40-mm HEI-T, SD FIXED AMMUNITION
MK 2 & MK 11 FOR AUTOMATIC GUNS.

the proplnt. The resulting flame is communicated to igniter of tracer and to the tracer. Near the end of tracer burning (ca 8 secs), the relay igniting chge is initiated. The bursting chge of proj may be detonated either by flame of the relay igniting chge or by PD fuze function, whichever occurs first. Total length of round is 12.81 inches, length of fuzed projectile 5.89 in, muzzle velocity 2600m/sec and max actual horizontal range 3500 yds. It is used in aircraft guns (Ref 40b, p 19 & Ref 52, pp 2-7 to 2-9)

40-mm HEI-T, SD MK2 and MK11 Fixed Ammunition for AUTOMATIC GUNS, shown in Fig 34, consists of a steel cartridge case crimped to the high-explosive-incendiary, tracer, shell-destroying, thin-walled, steel projectile, which is loaded with 63g of bursting charge (pressed TNT) and 36g of incendiary charge (Mg 23, Al 23, paraffin 3, Ba nitrate 48.5 & graphite 2.5%). The nose of the proj is threaded internally to receive the PD fuze MK27 and the "boat-tailed" base is threaded internally to receive the SD tracer assembly MK11 (Navy origin). This assembly consists of an igniting chge, a red tracer compn (burning for 8-10 seconds), and a relay igniting chge of BkPdr. The function of round is similar to that shown in Fig 33, except that its incendiary charge provides the possibility of setting target on fire. Total length of round is 17.60 inches, length of fuzed projectile 7.68 in, muzzle velocity 2870fps and max available horizontal range 5200 yds (Ref 40a, p 27 & Ref 52, p 2-19)

75-mm HEP-T, M349 (High-Explosive Plastic-Tracer) Fixed Artillery Ammunition, listed in Ref 40b, p 37, is classified. Its description is given in conf TM 9-1300-203-1(1967)

75-mm AP-T Fixed Ammunition M338A1 for Gun Cannons shown in Fig 35, consists of hardened steel monoblock body (called "shot" or "slug") with a flat nose. An Al or steel windshield (also called "ballistic cap" or "false ogive") is welded into forward end of the shot body. Total length of round is 23.67 inches and overall length of projectile is 12.38 in. The base of projectile is threaded internally to receive a red tracer which contains an igniter compn. The proj is assem-

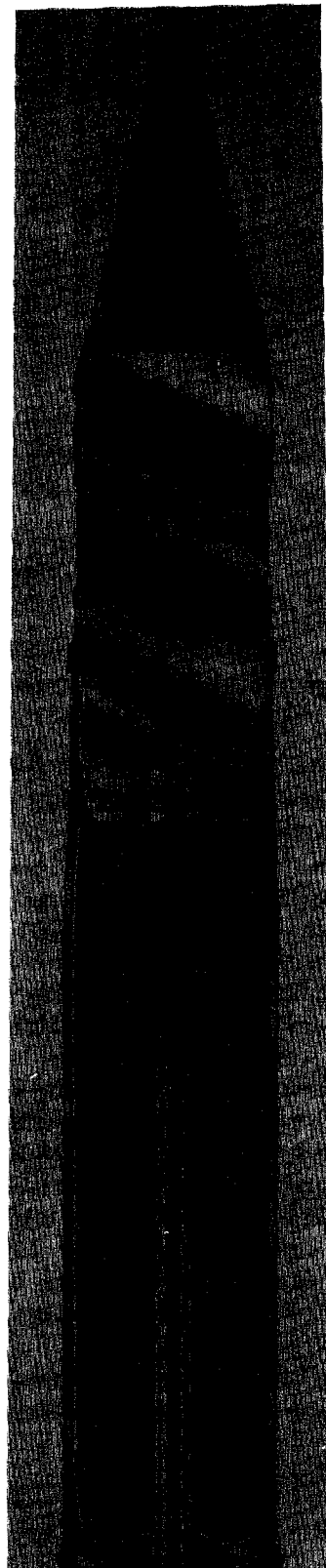

Fig 35 75-mm AP-T FIXED AMMUNITION M338A1 FOR GUN CANNONS

bled to the steel cartridge case by stab crimping. When the round is fired, the propelling gases drive the proj thru the bore of the gun, while at the same time the hot gases ignite the igniter of the tracer and the tracer itself. Burning time of tracer is ca 3 sec which corresponds to ca 1800 yds. On hitting the target, the windshield breaks and the slug penetrates the target solely by kinetic energy. Max range is 5000 yds. This round is used against armored ground targets (Ref 40b, p 32 & Ref 52, p 2-30)

75-mm APC-T Fixed Ammunition M61A1 for Gun Cannons, shown in Fig 36, consists of a steel cartridge case, stab crimped to projectile. The projectile consists of three parts: a steel monoblock body, a steel AP (armor-piercing) cap (its purpose is defined in Section 4) and a crimped Al, or lightweight steel ballistic cap (windshield). A cavity at the base of the body contains a small charge of Explosive D, a BD (base-detonating) fuze M66A1 and a 3-second red tracer (operating independently of fuze). The length of proj with fuze is 14.04 inches and total length of round 26.29 inches. When the propelling charge in the cartridge is fired, the resulting gases drive the proj thru the bore of the gun towards the muzzle and, while at the same time they ignite the tracer. On hitting the target, the windshield breaks allowing the AP cap and the body of projectile to drive thru the armor (such as of a tank). When inside the target the fuze functions and detonates the Expl D. The fuze functions with delay action to provide an opportunity for penetration before detonation occurs (Ref 40b, p 32 & Ref 52, p 2-29)

76-mm Canister Fixed Ammunition M363 for Gun Cannons, shown in Fig 37a, consists of a brass cartridge (loaded with 5-lb of single-base proplnt and fitted with a percussion primer), in which is crimped the canister. The body of canister consists of lightweight steel cylinder, welded at one end to a heavy steel base and sealed at the forward end by a closing disc. The body is loaded with ca 909 steel balls and the wall is provided with four equally-spaced longitudinal slits. Total length of round is ca 32.0 inches and length of canister is not given. Immediately after

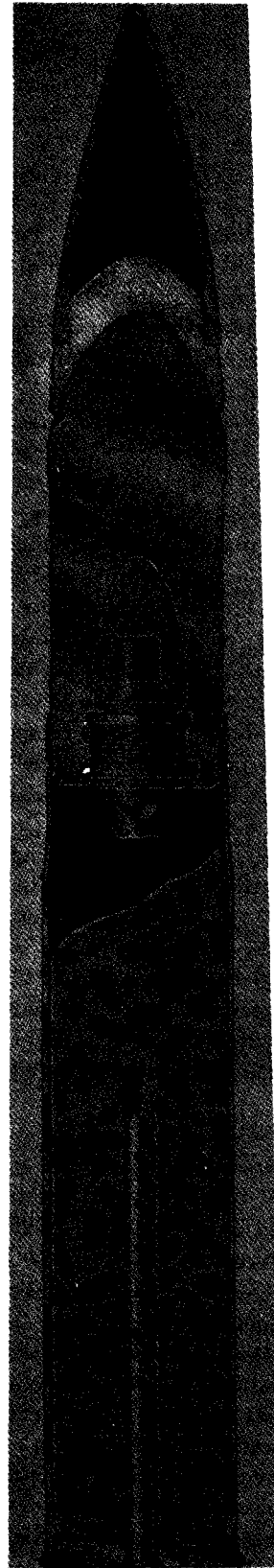

Fig 36. 75-mm APC-T FIXED AMMUNITION
M61A1 GUN CANNONS

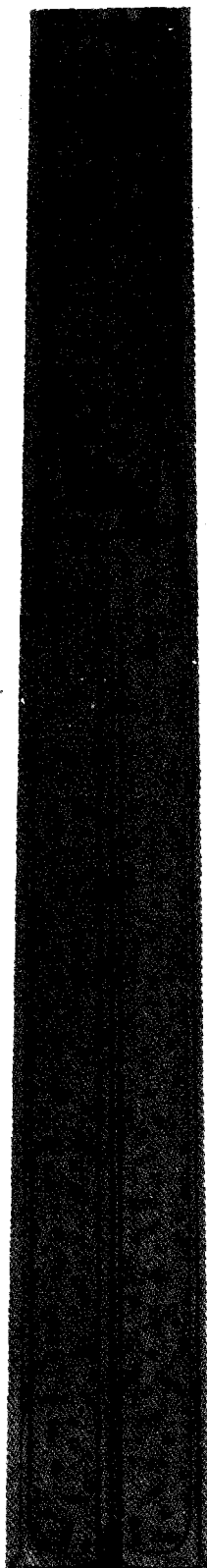

Fig 37a 76-mm CANISTER FIXED AMMUNITION
M363 FOR GUN CANNONS

the projectile leaves the muzzle of the gun, air pressure on the closing disc and centrifugal force acting on the body breaks it at four slits, with resultant dispersion of the balls. This proj is intended primarily against personnel at close range (Ref 40b, p 44 & Ref 52, p 2-39)

76-mm HVAP-DS-T (Hypervelocity, Armor-Piercing, Discarding Sabot-Tracer) Fixed Ammunition M331A1, intended for use in Gun Cannons against armor. It consists of a primed steel cartridge (loaded with 5.75-lb of triple-base proplnt M17) and a projectile having a very sharp nose. An outside view of round is given in Fig 37b. The proj consists of a dense core of tungsten carbide covered with a steel sheath, a base and a sleeve assembly called "sabot". A sheet steel release spider holds the core in place inside the sabot. The proj is inert, except for an M5 tracer in the base. Length of complete round 30.88 inches, wt 20.72 lb, max muzzle velocity 4125fps and max range 23630 yds. When the cartridge is fired, a setback ring moves rearward, opening the release spider. Setback holds the sabot and the core together until exit from the gun, at which time centrifugal force separates the sabot from the core. The M5 tracer, ignited by the propellant, provides a visible trace during the first few seconds of flight. On impact, the projectile sheath crumples and the tungsten carbide core penetrates the target (Ref 52, pp 2-42 & 2-43 and Ref 40b, pp 47 & 48) (Compare with APDS-T Projectile listed in this Section and shown in Fig 41)

90-mm APC-T Fixed Ammunition M82 for Gun Cannons, shown in Fig 38, is provided with a different type of igniter, but its projectile is similar to that shown in Fig 36. Length of complete round is 38.24 inches and its wt is 42.75 lb if 7.31 lb of proplnt M6 is used and 43.87 lb if 8.06 lb of the same proplnt is used. Muzzle velocities vary betwn 2600 & 2800fps and max range is 21400 yd. The rear cavity of proj contains 0.31 lb of Explosive D, a BD fuze and tracer integral with the fuze (Ref 40b, p 54 and Ref 52, pp 2-61 & 2-62)

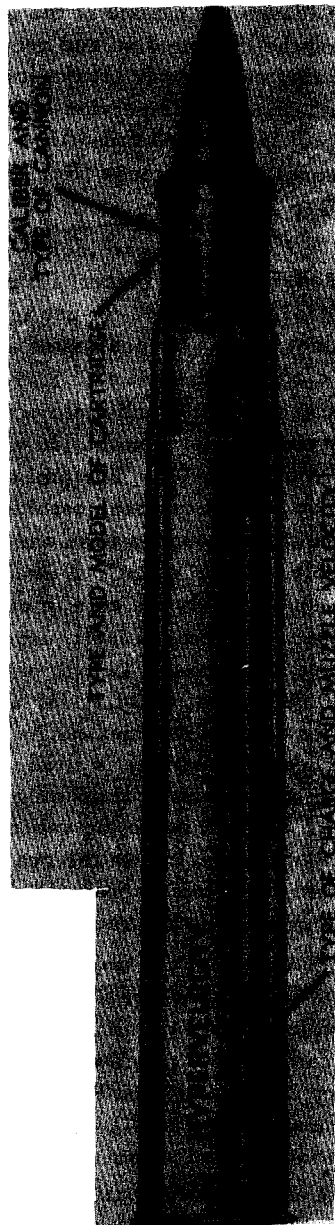

Fig 37b 76-mm HVAP-DS-T FIXED AMMUNITION
M331 SERIES FOR GUN CANNONS

90-mm HEP-T (High-Explosive, Plastic-Tracer) Fixed Artillery Ammunition, T142 and T142E3 listed in Ref 40b, pp 60 & 65, respectively, are classified. Their description is given in confidential Technical Manual TM 9-1300-203-1 (1967)

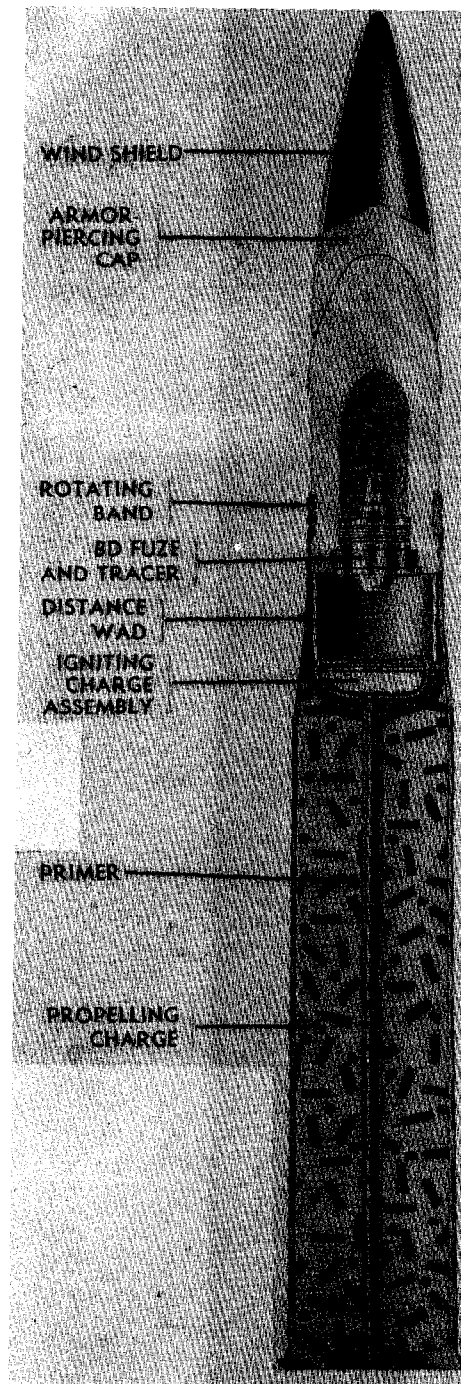

Fig 38 90-mm APC-T FIXED AMMUNITION
M82 FOR GUN CANNONS



Fig 39 90-mm HEAT FIXED AMMUNITION
M348A1 (T108E46) FOR GUN CANNONS

90-mm HEAT Fixed Ammunition M348A1 (T108E46) for Gun Cannons, shown in Fig 39, is provided with a rather complicated cartridge and a peculiar ignition assembly. This round fires a fin-stabilized projectile which contains a shaped charge of 1.56 lbs of Comp B loaded around a conical-shaped copper liner. The proj is fitted with a *tail boom* (qv) which houses the ignition cartridge. Another ignition cartridge is located in assembly of fins, T-shaped in cross-section. The retainer assembly screws into the base of fin assembly and the percussion primer, seated at the base of the cartridge case, screws into the base of the retainer assembly. The igniter fin assembly contains 400 grains of BkPdr; the retainer assembly contains ca 20 grains of BkPdr, and the percussion primer contains ca 7 grains of BkPdr. The project is assembled with a PIBD fuze and the piezoelectric element of the fuze is positioned in the nose of a windshield attached to the forward end of the projectile body. The cartridge case interior is fitted with guide rails to support and align the proj fins. When the percussion primer is struck, the flash it produces fires the igniter assembly, which, in turn, ignites the propelling chge. The force developed by burning of the proplnt breaks the retainer assembly and propels the proj from the gun. On impact, the bursting chge of fin-stabilized proj is detonated on functioning of the fuze, and the copper cone collapses, creating a high velocity shock wave and a jet of metal particles which penetrate the target (Ref 52, p 2-59)

90-mm HVAP Fixed Ammunition M332A1 for Gun Cannons, shown in Fig 40, consists of brass or steel cartridge case crimped to the hypervelocity-tracer projectile having a very hard armor-piercing core of tungsten carbide steel, weighing 8-lb. The body of proj is of Al alloy. It is provided with two sintered iron rotating bands near the base, a steel bourrelet at the forward end, a tracer assembly screwed into the base, an Al alloy nose, and an Al alloy windshield. Total length of round is 35.92 inches, length of proj 13.22 inches and muzzle velocity 3875fps. When proplnt is fired, the tracer, ignited by hot gases, burns for 3 seconds. Impact with target (such as heavy armor) breaks windshield and Al alloy body, which is followed by penetration of the core thru the target (Ref 40b, p 60 & Ref 52, p 2-64)

105-mm APDS-T (Armor-Piercing, Discarding Sabot-Tracer) Semifixed Ammunition M392A2 for Gun Cannons, consists of brass or steel cartridge case with crimped, spin-stabilized, projectile. Total length of round is 33.0 inches. The proj consists of a sheathed tungsten carbide core (which is an AP element), a sabot (assembled on its exterior surface), and a tracer. A plastic band is positioned on the outside of sabot at the forward end. A fiber rotating band and a plastic obturator are assembled on the outside of the proj near the base of the sabot. During proj flight, the tracer burns for a minimum of 2.5 seconds. The sabot discards upon leaving the gun muzzle (with velocity of 4850fps) by setback, centrifugal and air-pressure forces. The sheathed core penetrates the target by kine-

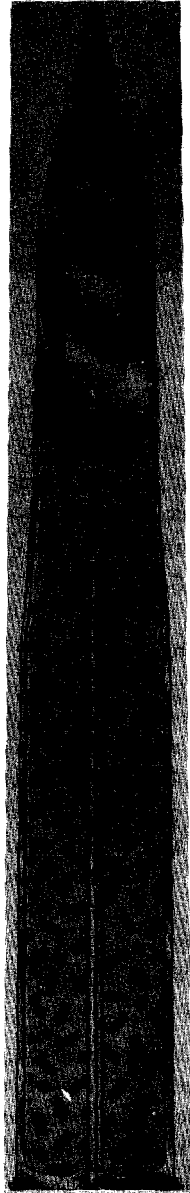

Fig 40 90-mm HVAP-T FIXED AMMUNITION
M332A1 FOR GUN CANNONS

tic force (Ref 52, pp 2-69 & 2-70)

As no cutaway view of US sabot projectile is given in Ref 52, we are referring the readers to the drawings of German sabot projectiles given on p Ger 171 of Ref 35, and to pp 363-71 of Ref 27b. About 12 types were developed in Germany before and during WWII

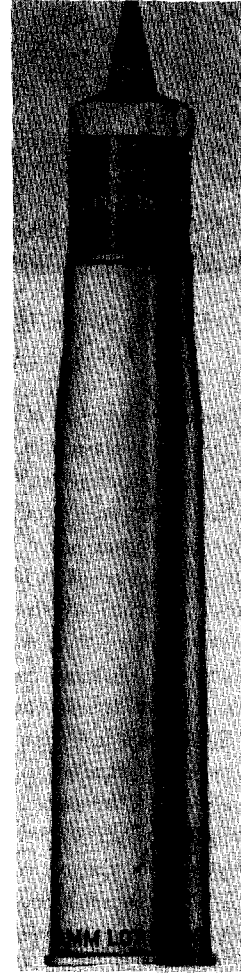

Fig 41 105-mm APDS-T SEMIFIXED
AMMUNITION M392A2 FOR
GUN CANNONS

105-mm HEAT-T Semifixed Ammunition M456 Series for Gun Cannons, shown in Fig 42, is intended for use against armored targets. The projectile consists of a steel body, a threaded standoff spike assembly, an aluminum chamber, a fin with boom, and a PIBD fuze assembly. The body contains a funnel shaped copper liner and is loaded with 2.38 pounds of Composition B. The chamber adapts the fin and boom assembly to the body, contains the fuze and is fitted with a plastic obturator band. The spike assembly is fitted with a nose cap which retains a piezoelectric element. The fin is threaded

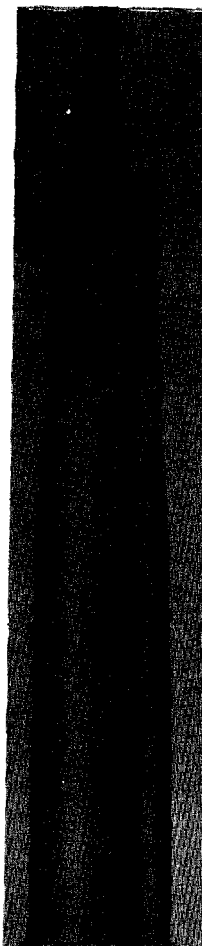

Fig 42 105-mm HEAT-T SEMIFIXED
AMMUNITION M456 SERIES
FOR GUN CANNONS

to receive a tracer. Cartridge cases of early manufacture were fitted with a threaded loading plug in the base of the case. Total length of round 29.34 inches, wt of proplnt M30 11.5 lb, muzzle velocity 3850fps and maximum range 8975 yds. During projectile flight, the tracer burns for a minimum of 2.5 seconds. When the projectile is detonated on impact by fuze functioning, the cone collapses, creating a high velocity shock wave and a jet of metal particles which penetrate the target (Ref 52, pp 2-70 & 2-71)

105-mm HEP-T (High-Explosive, Plastic-Tracer) Semifixed Artillery Ammunition M327, listed in Ref 40b, p 75 and Ref 52, p 2-118

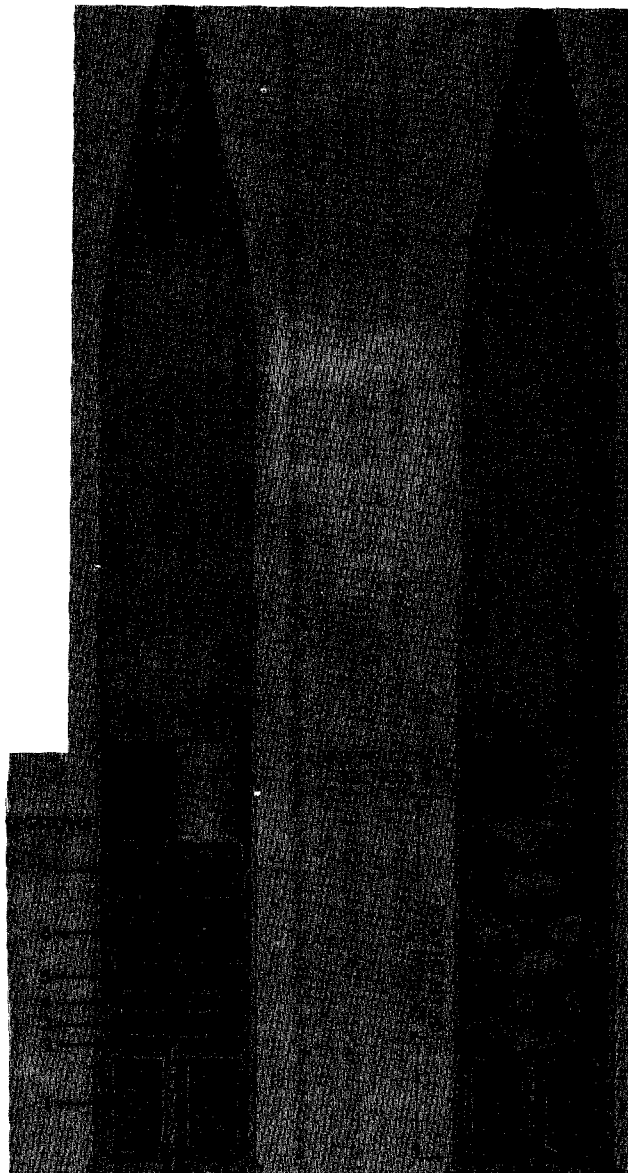

Fig 43a 105-mm HE SEMIFIXED AMMUNITION
M1 FOR HOWITZER CANNONS

is classified. Its description is given in confidential Technical Manual TM 9-1300-203-1 (1967). There is also the 105-mm HEP, which has no tracer

105-mm HE Semifixed Ammunition M1 for Howitzer Cannons, shown in Fig 43a, consists of a brass or steel cartridge case and a HE projectile provided with a PD fuze (length of fuzed proj 31.07 inches) and loaded with

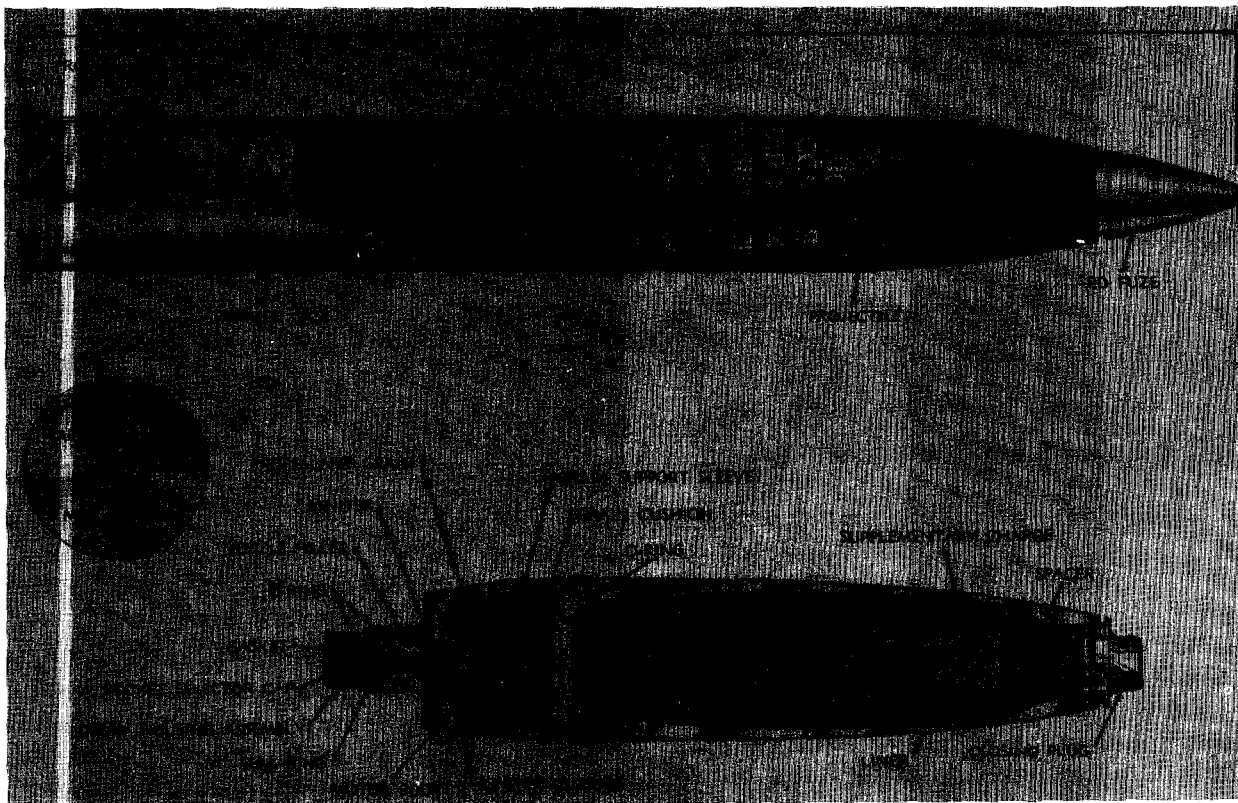

Fig 43b 105-mm HE, RA SEMIFIXED AMMUNITION
XM548 FOR HOWITZER CANNONS

4.8 lb of TNT or Comp B. The earlier type of cartridge, which is shown on the left side of Fig 42, contains the zoned charges of single-base propellant M1 of uniform single granulation. It is composed of a base charge (1) and six increment chges (2 to 7) for zone adjustments. The later type of cartridge, which is shown on the right side of Fig 42, contains 7 sections of M1 propnt of double granulation, known as "dualgran". The base chge (1) and increment (2) are filled with relatively small single-perforated grains (fast-burning), while increments (3-7) are loaded with larger size multiperforated grains (slow-burning). Total wt of full chge is 2.75 lb. The bags are tied to each other by twine in order to facilitate removal from the cartridge case. The bags are arranged along the long primer in such a manner that the open ends are staggered. Increment (5) incorporates

lead foil to act as a decoppering agent to protect the bore of the howitzer. Dualgran charges produce less flash than older types of chges, improve the uniformity of performance and increase accuracy. Maximum muzzle velocity 1550fps and max range 12330 yds. (Ref 40b, pp 67-9 & 165-66; Ref 52, pp 2-115 & 2-116)

Following is one of the more recent 105-mm rounds, among those described in Appendix (1967) to Ref 52:

105-mm HE, RA (High-Explosive-Rocket Action) Semifixed Ammunition XM548 for Howitzer Cannons, shown in Fig 43b, is used against personnel and materiel, producing blast and fragmentation at the target. The cartridge has an increased maximum range, reduced minimum range and greater lethality than HE cartridge M1 which contains 4.80 lb of TNT or 5.08 lb of Comp B.



Fig 43c 105-mm APERS-T (ANTIPERSONNEL-TRACER) SEMIFIXED AMMUNITION XM546 FOR HOWITZER CANNONS

The projectile which has a highly streamlined contour, is unique in that it is assembled with an integral rocket motor threaded in its base. The projectile is the deep-cavity type and is loaded with approximately 5.5 pounds of Composition B; the supplementary charge contains approximately .30 pounds of TNT. The rocket motor body, which is fitted with a sintered iron rotating band, is loaded with approximately 1 pound of XM33 propellant and pyrotechnic delay mixture contained in an ignition delay housing. The ignition delay housing is contained in an extension of the rocket motor base and is fitted with a threaded rocket selector cap. The projectile may be assembled with either a PD, MTSQ or VT fuze. Extended and intermediate range firing makes use of a 5-zone propelling charge (white bag) which is normally assembled in the cartridge case. Reduced minimum range firing makes use of a 2-zone propelling charge (green bag) which is issued separately. Overall length of round 32.7 inches, max muzzle velocity 1800fps and max range 15000 yds

Projectile functioning may be conventional; that is, with the rocket selector cap in place, the projectile is propelled from the gun normally and is functioned by the fuze with resultant blast and fragmentation. For extended range, the rocket selector cap is manually removed and the pyrotechnic mixture is ignited by the burning propellant gases as the projectile travels down the gun bore. While the projectile is in flight, the burning pyrotechnic mixture initiates the rocket motor propellant after a fixed delay. The functioning of the rocket motor adds thrust

to the projectile, increasing its range. Functioning is now normal in that when the fuze is functioned, the projectile detonates with resultant blast and fragmentation (Ref 52 & Appendix, pp 2-115 & 2-116)

105-mm APERS-T (Antipersonnel-Tracer) Semifixed Round XM546, shown in Fig 43c, is intended primarily for antipersonnel use at close and long ranges. It is also effective against personnel in dense foliage

The projectile consists of a two-piece aluminum body, an aluminum fuze adapter and a hollow steel base fitted with a sintered-iron rotating band and an M13 tracer. The fuze adapter threaded to the body contains four radially oriented detonators XM86, a flash tube, a relay M7 and detonator XM87, axially oriented, and a pyrotechnic-composition tracer. A central steel flash tube extends from the projectile base to the detonator in the fuze adapter. The projectile body is loaded with 8,000 eight-grain steel flechettes. A base charge of flake propellant M9 (in a plastic bag) and a plastic bag containing black marker dye are located in the hollow projectile base. An MT fuze is assembled to the projectile. The propelling charge consists of a two-increment charge (zones 6 and 7)

On firing, the fuze starts to arm immediately and will function as set: either on leaving the gun muzzle or at a preset time. Tracer M13, ignited by the propelling charge, provides a visible trace for the early stages of projectile flight. When the fuze functions, the four radially oriented detonators, the tracer in the fuze adapter and the axially oriented detonator and relay in the fuze adap-

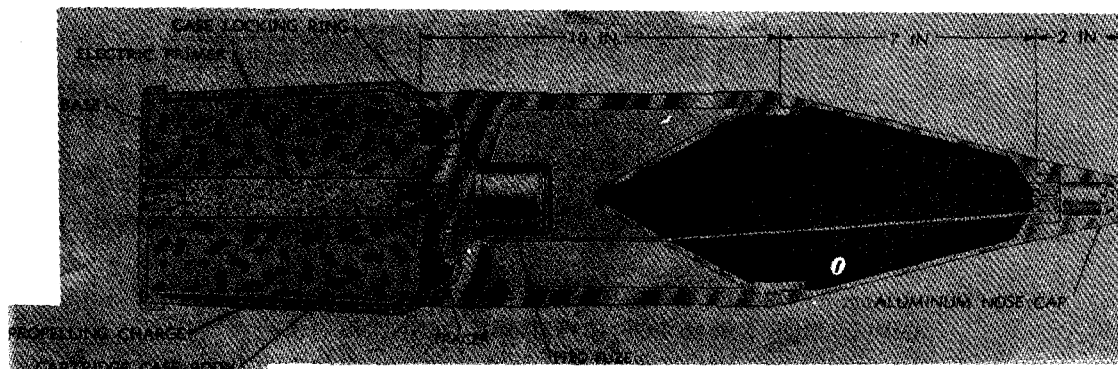

Fig 44a 152-mm HEAT-T-MP FIXED AMMUNITION
XM409E3 FOR GUN CANNON M81

ter are functioned. The explosive force of the radially oriented detonators rips open the forward skin of the projectile ogive, dispersing the flechettes in the forward section of the projectile by centrifugal force. At the same time, the axially oriented detonator and relay flash down the flash tube and ignite the base charge. The pressure built up by the burning base charge forces the flechettes and black marker dye in the rear of the projectile forward and out of the projectile. The tracer in the fuze adapter traces a ballistic path to the approximate center of the flechette pattern on the target area and burns for approximately 5 seconds. The primary purpose of the tracer in the fuze adapter is to provide a visual means of determining the adjustment of the weapon setting for impact in the target area. The black marker dye provides a black puff at the point of fuze function and is used to adjust time setting of the fuze

Length of complete round with fuze 34.15 inches, maximum muzzle velocity 1700-1800fps and max range 328 yds (300 meters). Its propellant charge consists of 3.1 lb of proplnt M30A1, which is a modification of triple-base proplnt M30 listed in Vol 2 of Encycl (Ref 48) p C34, Table V (Ref 52 and its Appendix, pp 2-112 & 2-113)

Ammunition for 37-mm to 105-mm inclusive is either "fixed" or "semi-fixed" (See Ref 43, p A385-L). Ammunition of larger caliber can be either "separated" (such as

for 120-mm guns) or "separate-loading" (such as for 155-mm guns). Description and cutaway views of projectiles used in "separated" and "separate-loading" ammunition are given in Section 4, Part B

There are, however, some 152-mm rounds of ammunition, which are "fixed". Their cartridge cases are combustible. Following are two examples:

152-mm HEAT-T-MP (High-Explosive-Antitank-Tracer-Multipurpose) Fixed Ammunition XM409E3 for Gun Cannon, shown in Fig 44a, is 26.98 inches long, muzzle velocity 2240fps and range 9850 yds. It is a chemical energy round with antipersonnel capacity. It consists of a one-piece forged projectile assembled to an XM157 combustible cartridge case, which has two separate parts: a body (made of felted colloided NC), and a base. The body, which holds 6.25 lb of smokeless propellant M26 in a cloth bag, is cemented to the base by means of NC lacquer. The combustible body similar to those described under "Combustible and Consumable Cartridge Cases" in Vol 3 of Encycl, p C420-R (Ref 48), is attached to the projectile base with epoxy resin and an aluminum ring. The cartridge base case is fitted with the consumable electric primer igniter XM91E1 which consists of a colloided NC tube loaded with 1230g of Class 1 BkPdr [See Vol 2 of Encycl, p B171-L (Ref 44)] in a plastic bag; and also a head holder contg an electric igniter, initiator, bridge wire and a paper closing plug.

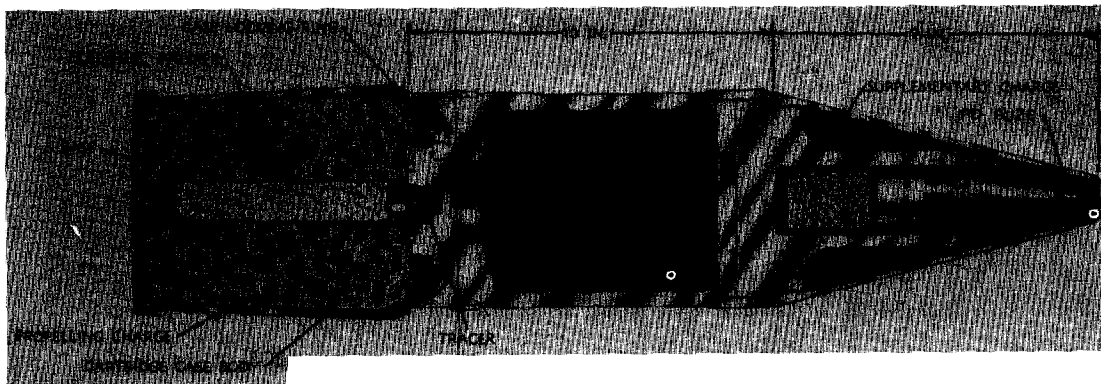

Fig 44b 152-mm TP-T FIXED AMMUNITION
XM411E3 FOR GUN CANNON M81

The head holder is surrounded by Ball Powder [See Vol 2, p B11-R (Ref 44)] for support and combustibility. It is attached to the base of the primer tube by an epoxy resin. The paper closing plug, attached with NC lacquer, seals the forward end of the tube. This primer assembly is classified as combustible because it is made of materials which are totally burned on functioning. The projectile HEAT-T-MP is loaded with 6.3 lbs of Comp B shaped around a copper liner. A steel ring locks the liner in place and houses an insulator and wire eyelet assembly. The terminal of the control power supply (used to initiate the PIBD fuze) fits into insulator. A windshield cap, threaded to the windshield protects the control power supply during flight, transportation and handling. A sintered-iron rotating band located 1.75 inches forward of the proj base provides spin and obturation. The M13 tracer, located in an aluminum adapter in the base of projs consists of a steel cup contg 1.8g of igniter compn and 5.7g of tracer compn. When the weapon is fired, an electric current from the firing mechanism flows thru bridgewire. The resulting heat ignites the priming compn and finally the BkPdr in plastic tube (Ref 52, pp 2-85 & 2-86). The flame of BkPdr ignites the tracer and the propelling chge. The resulting high pressure, caused by hot gases of combstn, forces the spin-stabilized projectile out of the gun tube and propels it to the target. When the round is used for defeat of armor (as an antitank), electrical energy

from the control power supply in the nose of the projectile is fed to the PIBD fuze on impact. The functioning of the fuze detonates the bursting chge of Comp B, collapsing the copper cone liner and creating a high-velocity shock wave and a jet of metal particles which penetrates the target

For A/P (antipersonnel) use, the round is so arranged that the fuze will function due to graze rather than to impact, and the blast and fragmentation created by detonation of the bursting chge inflicts casualties among the personnel (Ref 52, pp 2-85 & 2-86)

152-mm TP-T (Target Practice-Tracer) Fixed Ammunition XM411E3, shown on Fig 44b, is intended for training in gunnery and fire control. The complete round (26.663 inches long), consisting of a hollow forged steel projectile assembled to a combustible cartridge case XM157, is designed as a ballistic match for 152-mm HEAT-T-MP round XM409E3 (shown in Fig 44a). The projectile body is threaded at the forward end to receive an Al "spike" which houses a fuze adapter, a small charge of explosive (called "supplementary") (serving as a "spotting" charge), and a PD fuze. A steel windshield threaded to the base of the spike serves as a protective covering for the fuze and the spike assembly. The cartridge case contains ca 6 lb of propellant in a cloth bag and is fitted with an electric primer-igniter. An Al adapter in the base of the projectile contains an M13 tracer. When the proj hits

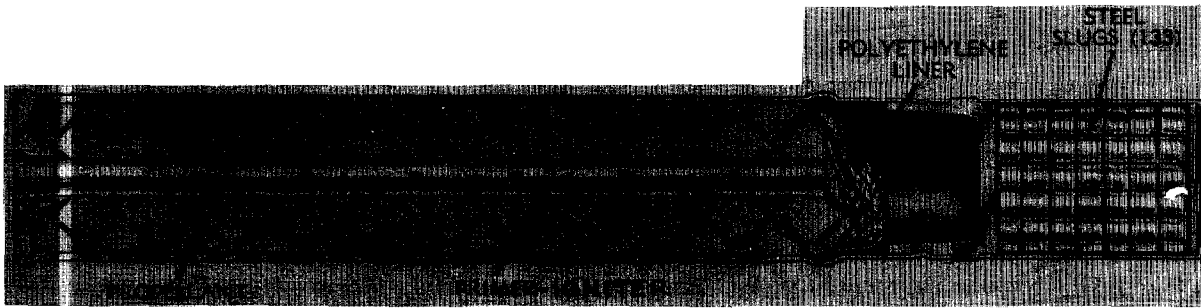

Fig 45 57-mm CANISTER FIXED AMMUNITION
T25E5 FOR RECOILLESS RIFLES

the target, the fuze detonates the "spotting" charge and the resulting flash indicates the spot where the proj lands (Appendix to Ref 52, p 2-86.3)

Similar fixed rounds with combustible cartridges include: 152-mm Canister XM625 (Appendix to Ref 52, p 2-86) and 152-mm HEAT-T-MP, XM409E4. The latter round is modification of XM409E3 (Appendix to Ref 52, p 2-86.3)

Conventional primer-igniters are also used in some recoilless gun (rifle) cartridges, such as, for example in 57-mm Canister Ammunition (shown in Fig 45); 75-mm HEAT-T Ammo (Fig 46); 90-mm Canister Ammo (Fig 47); and 106-mm HEAT Ammo (Fig 49). A different system of ignition is used in 105-mm HEAT Ammo M341 (Ref 52, p 3-26). This system shown in Fig 48 is similar to that used in 90-mm HEAT Fixed Ammunition M348A1 (T108E1) (See Fig 39)

Examples of Recoilless Rifle Ammunition
37-mm Canister Fixed Ammunition T25E1 for Recoilless Rifles, shown in Fig 45, consists of perforated steel cartridge case

crimped to a thin steel canister projectile (similar to that shown in Fig 37) contg 133 stacked cylindrical, steel slugs. When the firing pin of the rifle strikes the percussion primer in the base of the cartridge, the resulting flash ignites the BkPdr chge in the primer-igniter and its flame ignites thru the perforations of the tube the propellant chge. Gas build-up from the burning propellant expels the canister from the rifle and propels it to the target. The pre-engraved rotating band, engaged with the rifling of the bore of the weapon, imparts spin to the projectile. There is practically no recoil in such rifles because part of propelling gases escape thru the perforation in the cartridge to the rear of the bore and then thru the orifices into atmosphere (For a description of recoilless rifle, see Ref 44, p C28-R). Muzzle velocity is only 1200fps and max effective range only 175 ft (Ref 52, pp 3-4 & 3-5)

75-mm HEAT-T Fixed Ammunition for Recoilless Rifles, shown in Fig 46, consists of perforated, plastic-lined steel cartridge case crimped to high-explosive antitank

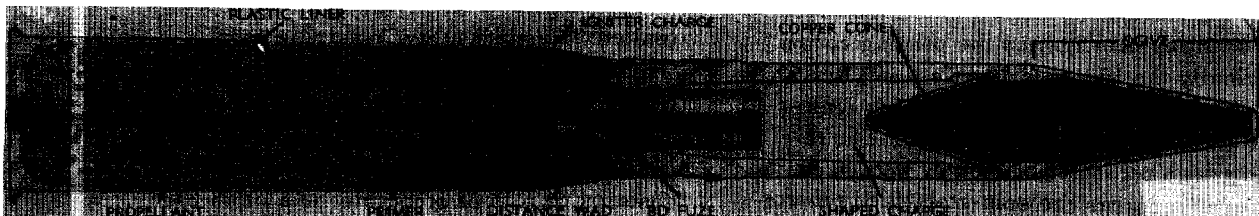

Fig 46 75-mm HEAT-T FIXED AMMUNITION
M309A1 FOR RECOILLESS RIFLES

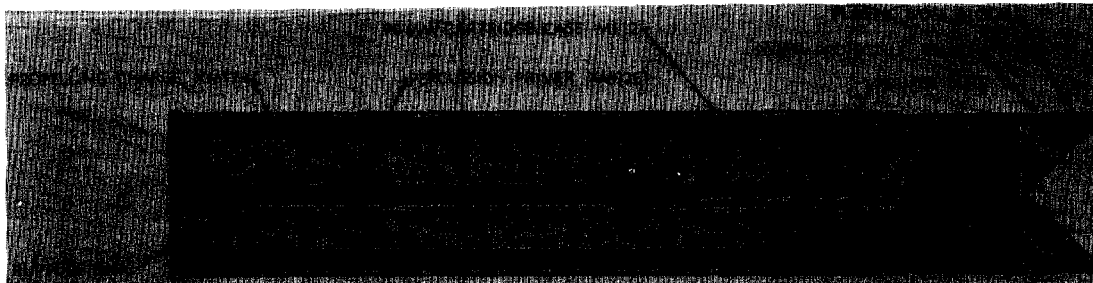

Fig 47 90-mm A/P CANISTER FIXED AMMUNITION
XM590 FOR RECOILLESS RIFLES

projectile, which is loaded with shaped charge (1 lb of Comp B). The cone of shaped charge is covered with a thin Cu cone which is held in place in the interior of the projectile by the adapter. The space in front of Cu cone provides the standoff necessary for the penetration of the target. When round is fired, the propellant gases ignite the tracer at the base of projectile, while at the same time they drive the proj thru the muzzle of the weapon. On impact with the target the BD fuse detonates Comp B. This creates high-velocity shock wave which collapses Cu cone creating a rapid jet of metal particles, which penetrate the target. Muzzle velocity is only 1000fps (Ref 52, pp 3-13 & 3-14). An outside view of 75-mm HE cartridge for recoilless rifle is given in Ref 44, p C75-R

90-mm A/P (Antipersonnel) Canister Fixed Ammunition XM590 Series for Recoilless Rifles, shown in Fig 47, consists of a perforated steel case crimped to an unfuzed Al projectile contg a payload of low-drag, fin-stabilized steel-wire fragments, called "flechettes". A plastic wedge-shaped, nose

block capping the Al cylinder serves to facilitate its break-up in flight. The heavy Al base of the proj is perforated with three bleed holes, each 3/16 inch of diameter. When propellant is ignited on firing the round, the above bleed holes permit the propellant gases to build-up pressure inside the canister before they leave the bore. There, during the flight, this pressure, in conjunction with air pressure on the plastic nose block, breaks up the canister wall, thus releasing the flechettes to hit the enemy (Ref 52, pp 3-18 & 3-19)

105-mm HEAT Fixed Ammunition M341 for Recoilless Rifles, shown in Fig 48a, consists of a perforated steel cartridge case contg 8.10 lb of propellant, and a lightweight, PIBD (point-initiating, base-detonating)-fuzed projectile contg a shaped charge of 2.38 lb Comp B. The proj is also fitted with a tail boom and tail assembly contg a percussion primer and two ignition cartridges. The cartridge case is secured at the base of the proj by the percussion primer. The primer is designed with a weak point which fails when the cartridge is fired. This releases from the case the fin-stabilized proj and, when it

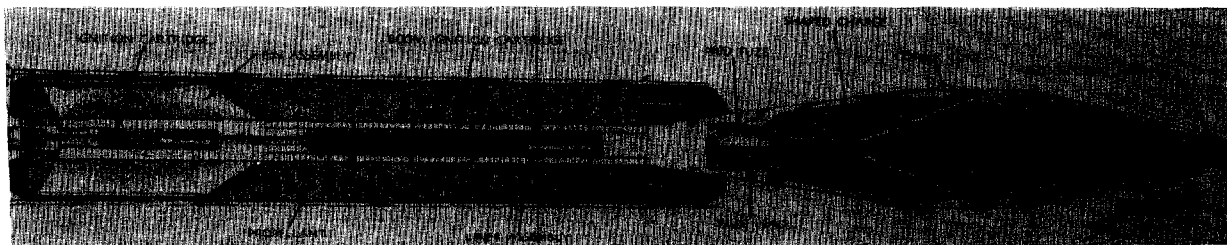

Fig 48a 105-mm HEAT FIXED AMMUNITION
M341 FOR RECOILLESS RIFLES

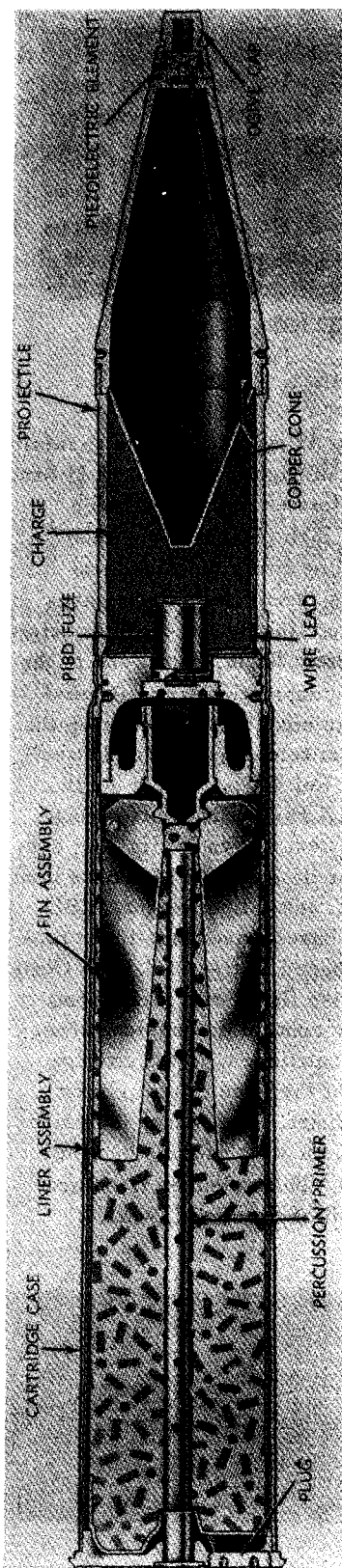

Fig 49 106-mm HEAT FIXED AMMUNITION M344A1 FOR RECOILLESS RIFLES

hits the target, the fuze detonates the charge causing the collapse of copper cone. This creates a high-velocity shock-wave and a jet of metal particles that penetrates the target. Length of round 37.10 inches, muzzle velocity 1650fps and range 1600 yds (Ref 52, pp 3-25 & 3-26)

106-mm HEAT Fixed Ammunition M344A1 for Recoilless Rifles, shown in Fig 49, consists of perforated thin-walled steel cartridge and a thin-walled steel projectile which contains a shaped charge of 2.79 lb Comp B loaded around a Cu cone. The proj is threaded at the forward end to a ballistic cap, which forms an ogive and mounts the piezoelectric element. The base of the proj contains the PIBD fuze, and the fin & piston assembly. The cartridge case contains 8.06 lb of proplnt M26 in a rayon and plastic liner and is fitted at the base with a percussion primer. Overall length of round is 39.31 inches, muzzle velocity 1650fps and maximum range 3000 yds. When fired by percussion primer at the base of cartridge, the proplnt ignites and resulting gases start to drive the proj towards the muzzle of rifle. While the proj is traveling through the bore of the weapon, propellant gases are trapped in the piston in the base of the projectile. Once the projectile leaves the muzzle, those gases move the piston to the rear and open the six folding fins of the fin assembly to provide stabilization in flight. On impact, the piezoelectric element in the ballistic cap functions the PIBD fuze. This detonates the bursting charge, causing the copper cone to collapse. Collapse of the cone creates a high-velocity shock wave and a jet of metal particles that penetrate the target

Section 3, Part D

c₃) Detailed Description of Artillery Primer-Igniters and of some Primers Used in Cartridge Ammunition

US military primer-igniters may be identified by designations M1, M1A1, M1A2, M2, M2A1, etc (See Nomenclature in Section 2, Part B) and by the weight of the BkPdr charges in igniters. For example, "65-grain Primer" contains 65 grains of BkPdr

Figs 50, 51 & 52 which follow, show several items under the names given in Technical Manuals as "percussion primers". Of these only "primer M36A1" is a primer, while all others are "primer-igniters", as was explained in item c₁

As can be seen from Figs 50-52 and also from Figs 33 to 38, 40, 45, 47 and 49, igniter

tubes are of different lengths and some of them are very long. It was formerly assumed that BkPdr chge must occupy entire length of igniter tube. Later, however, it was decided that better characteristics are obtained in some cases by using a shorter charge, retaining it in the tube with a cup and allowing the flame to shoot into empty part of the tube

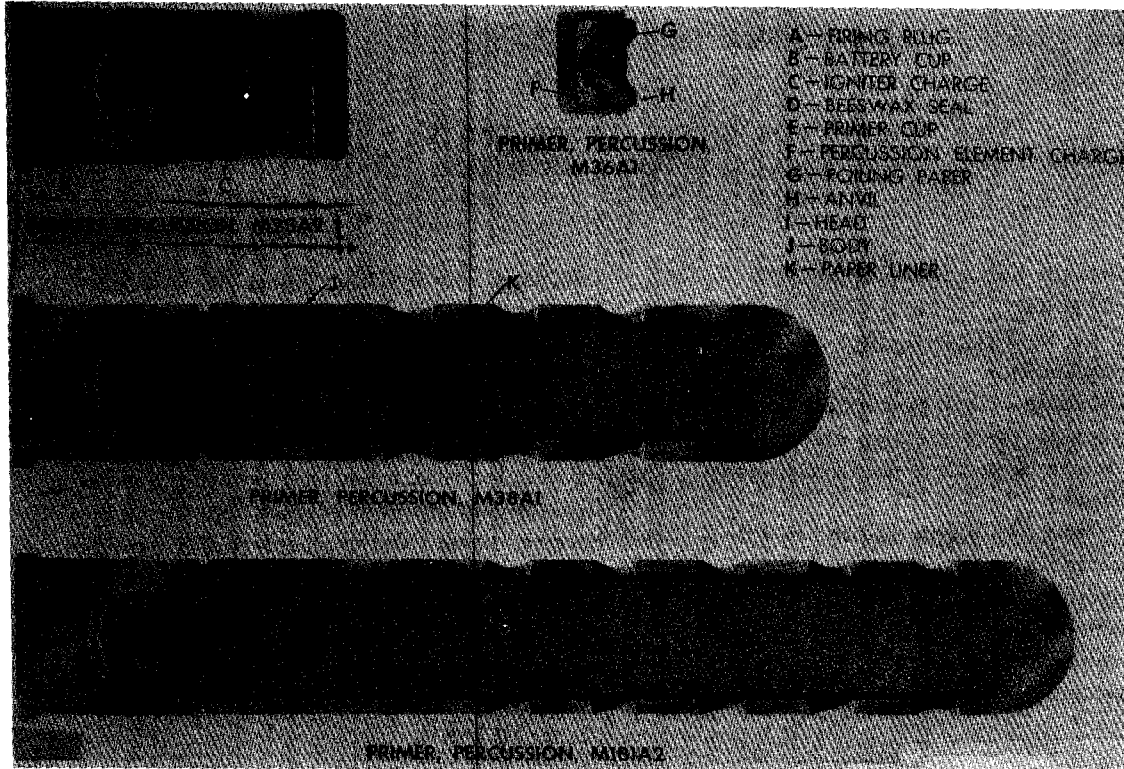

Fig 50 PRIMERS FOR IGNITING PROPELLANTS IN FIXED AND SEMIFIXED AMMUNITION

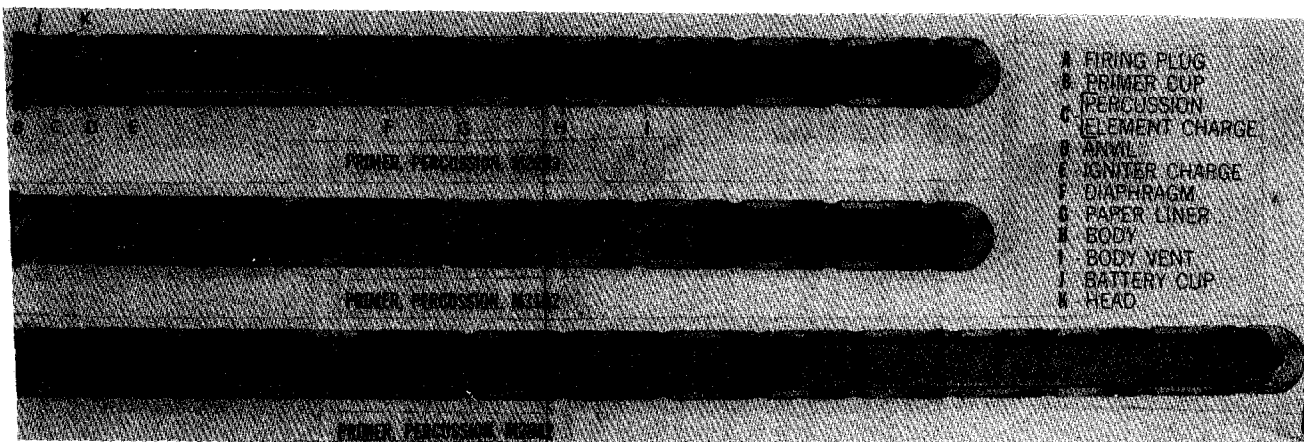

Fig 51 PRIMERS FOR IGNITING PROPELLANTS IN FIXED AND SEMIFIXED AMMUNITION

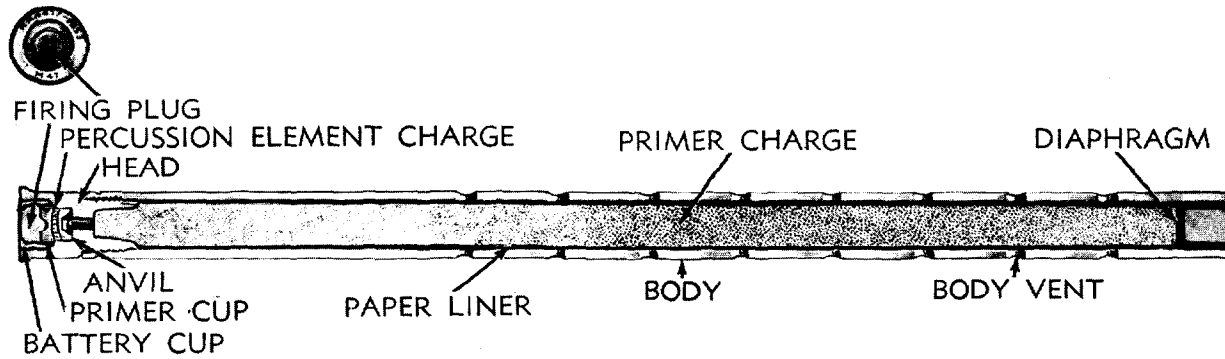

Fig 52 PRIMER FOR IGNITING PROPELLANTS IN RECOILLESS RIFLES AMMUNITION

and then thru the holes into proplnt chge (Refs 17, 32 & 52)

Fig 52 shows a primer-igniter for recoilless rifle ammunition

The above described primers are of percussion type, but there are also electric, combination electric & percussion, friction and ignition primers

Electric Primer. This type is fired by the heat generated when an electric current passes thru a resistance wire or conductive primer mixture embedded in a primer compn. It was formerly used in harbor defense and railroad artillery ammunition (Ref 15, p 117), but is

now used in rapid-firing 20-mm AC (Aircraft) Guns, since they require nearly instantaneous initiation. Such a primer is shown on Fig 53 as compared with a mechanical primer. The electrical primer consists of a primer cup separated from the primer anvil by the charge. As the electric current passes thru the chge from the button to the support cup, the chge becomes heated and explodes (Ref 32, p 139) (See also Electric Primer M30, Fig 69, Ref 15) *Combination Electric and Percussion Primer.* This type is fired either electrically or by the blow of a firing pin. It has been used in separate-loading rounds (See Fig 54 for Primer MK15A1)

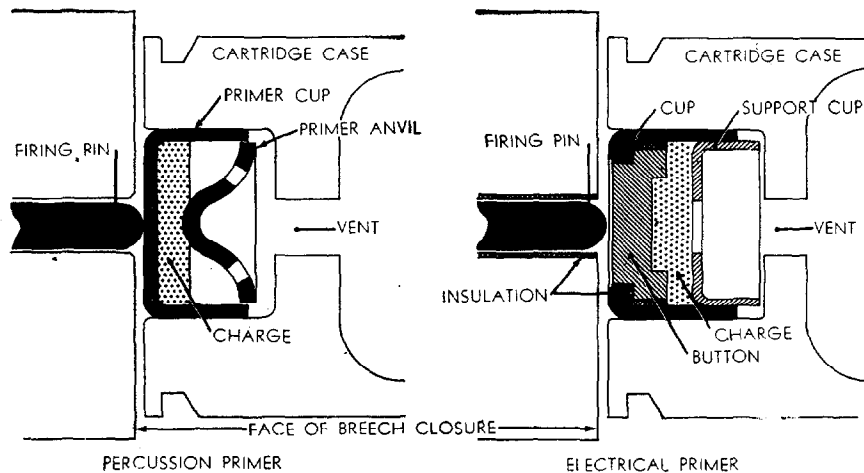

Fig 53 COMPARISON OF ELECTRIC PRIMER WITH PERCUSSION PRIMER

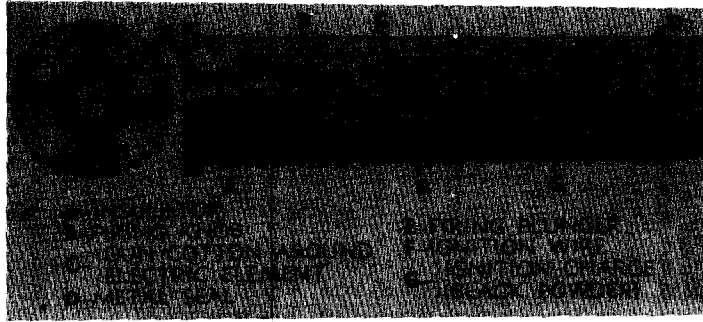

Fig 54 COMBINATION OF ELECTRIC AND
PERCUSSION PRIMER MK15Mod2 FOR
SEPARATE-LOADING AMMUNITION

Combination Electric and Percussion Primer MK15, Mod 2, shown in Fig 54, may be fired either electrically or by the blow of a firing pin. It has been used in separate-loading ammunition, such as the 280-mm HE, M124 (T122E4) w/Suppl Chge (Ref 52, p 2-129)

Electric and Percussion Primer M75 (T106E1) is similar to MK15 primer except in some minor details (Ref 52, p 2-129)

Electric Primer MK34 Mod 0 is similar in construction to MK15 primer, except that it is designed for electrical initiation only and cannot be activated by percussion (Ref 52, p 2-129)

Friction Primer. This type is fired by the heat generated when a serrated plug is pulled thru an expl compn sensitive to heat and friction. The primer M1914 is represented in Fig 69, p 116 of Ref 15 and described on p 117 as being used as a substitute for the electric primer in the event of failure of electric power. No friction primer is described in later editions of TM 9-1900

Ignition Primer. This type, although somewhat similar to the percussion type, differs in that it contains in lieu of percussion element, an inert cap with a hole in it. It is intended for use in certain subcaliber ammunition fired by a service primer. The flash from the service primer passes thru the hole in the cap of the primer, thus igniting the BkPdr chge located in that primer (Ref 15, p 117 & Ref 32, p 141)

Section 3, Part D

c₄) Primers for Igniting Propellants in Cartridge Bags Used in Separate-Loading Ammunition.

Primers used for igniting propellant chges in the bags of separate-loading ammunition weapons of 155-mm and larger calibers are shown in Figs 56 & 57. The bags used in conjunction with these primers are shown in Fig of Ref 44, p C77-L, in Fig 55 in this Section and in Figs 1-4b & 1-5b in Section 4, Part B

In this type of ammunition, the primer is not connected with the bag, but is located in a hole drilled parallel to the axis of the breechblock and is a part of firing mechanism. The flame produced on burning of BkPdr in the tube (See Figs 56 & 57) (which is not perforated as in the case of tubes used in fixed, semifixed and separated ammunition) projects inside the propellant chamber to ignite the small charge of BkPdr in the disc-like bag attached to the end of cartridge bag. This small bag with BkPdr is known as *igniter*. Additional igniter chges can be attached to other bags and to increments of proplnt

Since the BkPdr charges of primers shown in Figs 56 & 57 do not penetrate inside the proplnt chges (as in case of cartridge ammunition) there is no necessity for long tubes and for perforations in them

It might be said about this type of ammunition, that there are several igniters of BkPdr,

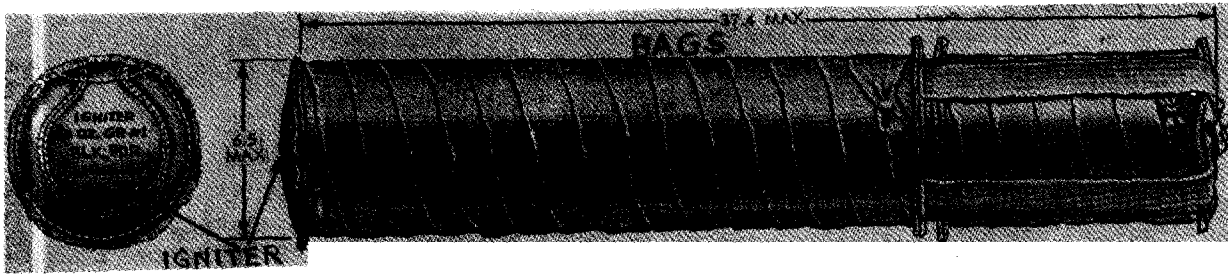

Fig 55 PROPELLING CHARGE M19 FOR 155-mm SEPARATE-LOADING GUN AMMUNITION

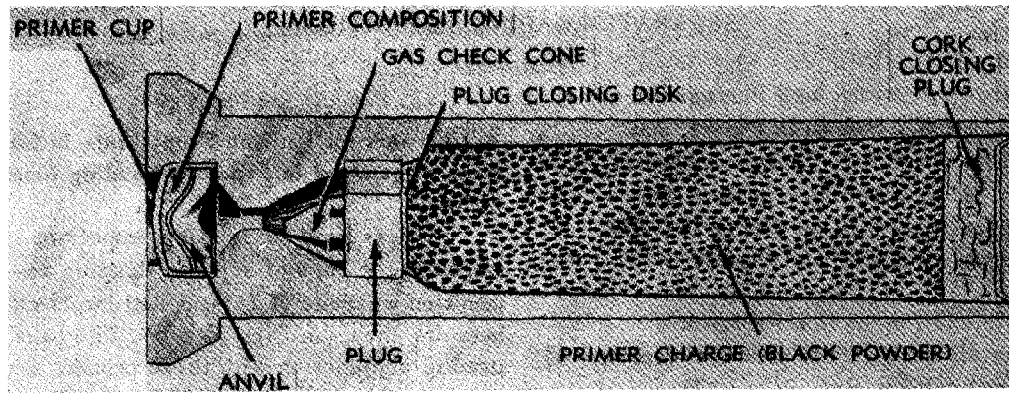

Fig 56. PERCUSSION PRIMER MK2A4 FOR IGNITING PROPELLANT IN SEPARATE-LOADING AMMUNITION

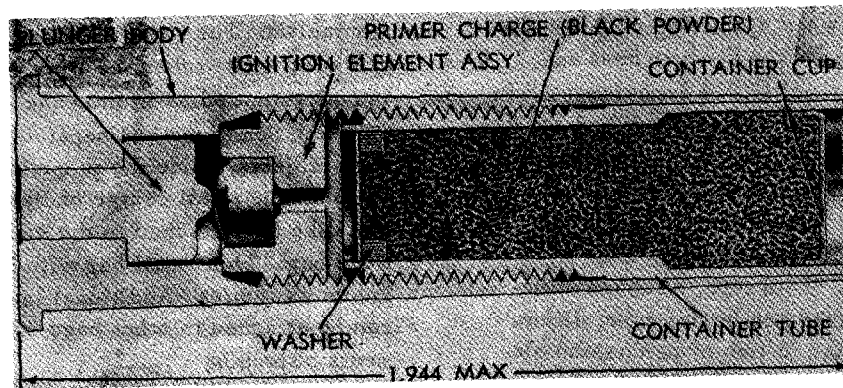

Fig 57 PERCUSSION PRIMER M82 FOR IGNITING PROPELLANT IN SEPARATE-LOADING AMMUNITION

of which one is an integral part of primer, while others are located in small bags (Refs 17, 20a, 32 & 52)

Section 3, Part D

d) Primers Used in Demolition Charges and in Land Mines.

Following are examples of percussion primers used in these items, in conjunction with igniters and firing devices described here. Essentially each of them (See Fig 58) consists of a copper or gilding metal cup with a flange at one end and a hole at the other end. They are loaded with priming mixtures such as contg Basic Lead Styphnate, Ba nitrate, Sb trisulfide and Tetracene

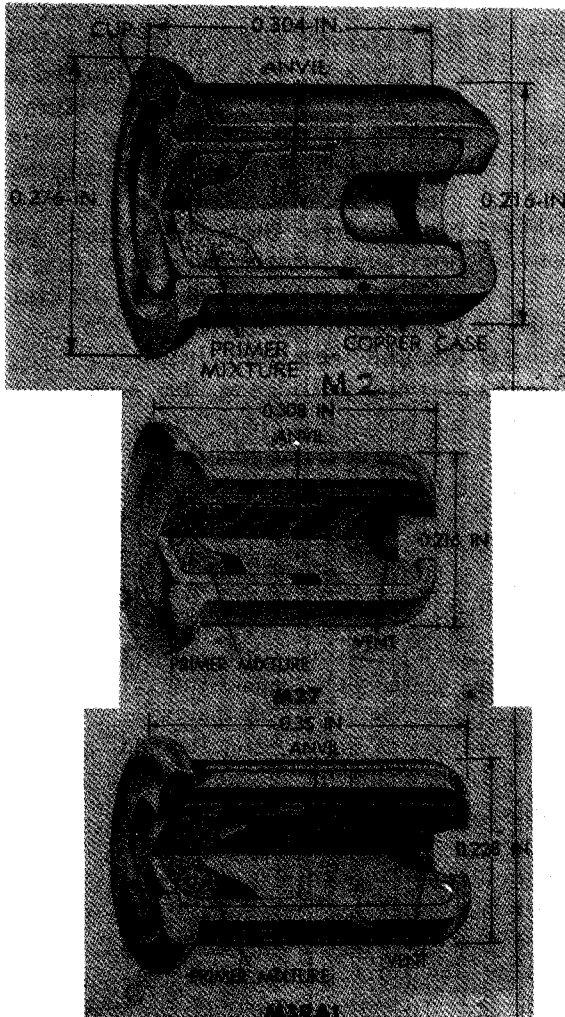

Fig 58 PERCUSSION PRIMERS M2, M27 & M39A1 USED IN DEMOLITION DEVICES AND LAND MINES

Section 3, Part D

e) Primers and Igniters for Initiating Mortar Propellants and Description of Some Mortar Projectiles

Here primers and igniters are separate elements and not in one piece as for igniting propolnts in gun & howitzer cannons, and in recoilless rifles. The weapons known as 60-mm Mortar Cannons M2 & M19 and 81-mm Mortar Cannons M1 & M29 are smooth-bore,

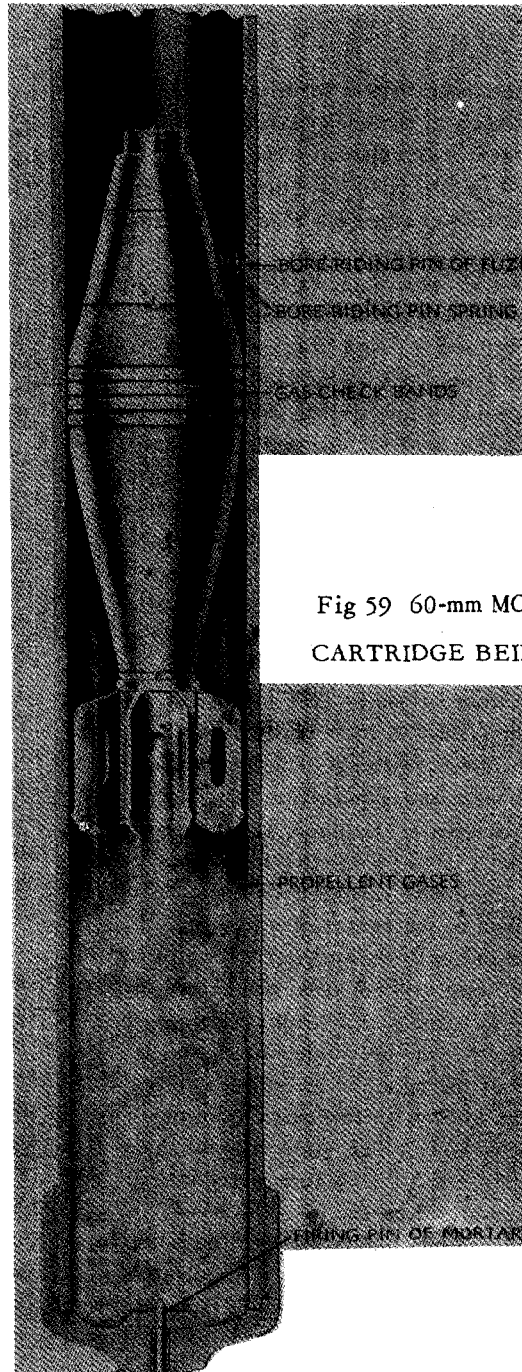

Fig 59 60-mm MORTAR CARTRIDGE BEING FIRED



Fig 60 PRIMER AND IGNITION CARTRIDGE
FOR 60-mm MORTAR

muzzle equipped with bipod for high-angle firing. The bases of these mortars are equipped in the center with removable firing pin (as shown in Fig 59) when used for drop fire. Mortar M19 is also equipped with a mechanism permitting the use of lever firing.

Percussion Primer, such as M32 (See Fig 60) consists of a threaded head into which is assembled a firing plug, and a housing contg a percussion element pressed into one end, and hollow BkPdr pellet assembled into the other end. The head and housing are made of either steel or brass. The housing is crimped into the head and a paper disk which is shellacked to the exposed end of the housing holds the pellet in place. It is screwed into the shaft of projectile after insertion of the ignition cartridge, which is usually M5A1 (See next item)

Ignition Cartridge M5A1 (Fig 60), consists of an outer tube, ca 5/8 inch in diam and a shorter inner tube, known as "flash tube"; both made from layers of paraffined cartridge-paper. The purpose of the paper flash tube (which is empty) is to permit the flame from the primer to penetrate the ignition cartridge chge down to its center, thereby producing better and uniform ignition. A chipboard washer, with a paper tube cemented into a center hole and a thin paper disc cemented to one face of the washer and over the other end of the tube, is assembled into one end of the body with the small tube extending into the body. The outer tube of the body is crimped inward to secure the washer and tube assembly in place. A charge of propnt (ca 40 grains) is loaded into the body and a chipboard closing disk is crimped into the remaining open end of the body. The

half of the body contg the washer and tube closure is colored red, while the remaining half with chipboard disk is colored yellow. The red end must be assembled adjacent to the primer (Ref 42, p 86). Ignition cartridge is inserted into fin assembly ahead of the primer. The shaft, in turn, is screwed into the base of projectile, which is made either from pearlitic malleable iron or from steel. Propellant M9 [See Vol 2, p C35, Table VI (Ref 44)] charge consists of several increments sealed in individual cellophane bags (usually four for 60-mm mortars and up to nine for 81-mm weapons). The bags are placed either between or within the blades of fins. The assembly of igniter cartridge and the propnt increments make up the required propnt chge. When firing at a very short range in the 60-mm mortar or with the light-weight projectile in the 81-mm mortar, no increments are used but just ignition cartridge. In firing by the *drop* method, the round is allowed to slide into the barrel and upon reaching the bottom, the round's primer impinges upon the firing pin of the mortar. The impact sets off the primer chge and the blast from the exploding mixture ignites the BkPdr pellet and carries on into the end of the ignition cartridge. This blast, amplified by the flames from the burning pellet, ignites the small propnt chge in the ignition cartridge which, in turn, blows thru radial flash holes in the fin body of the cartridge container to ignite the propellant M9 [See Vol 2, p C35, Table VI (Ref 44)] increment chges. The gas produced on burning of combined ignition and propnt chges forces the projectile from the barrel. The bourrelet or gascheck band, pre-

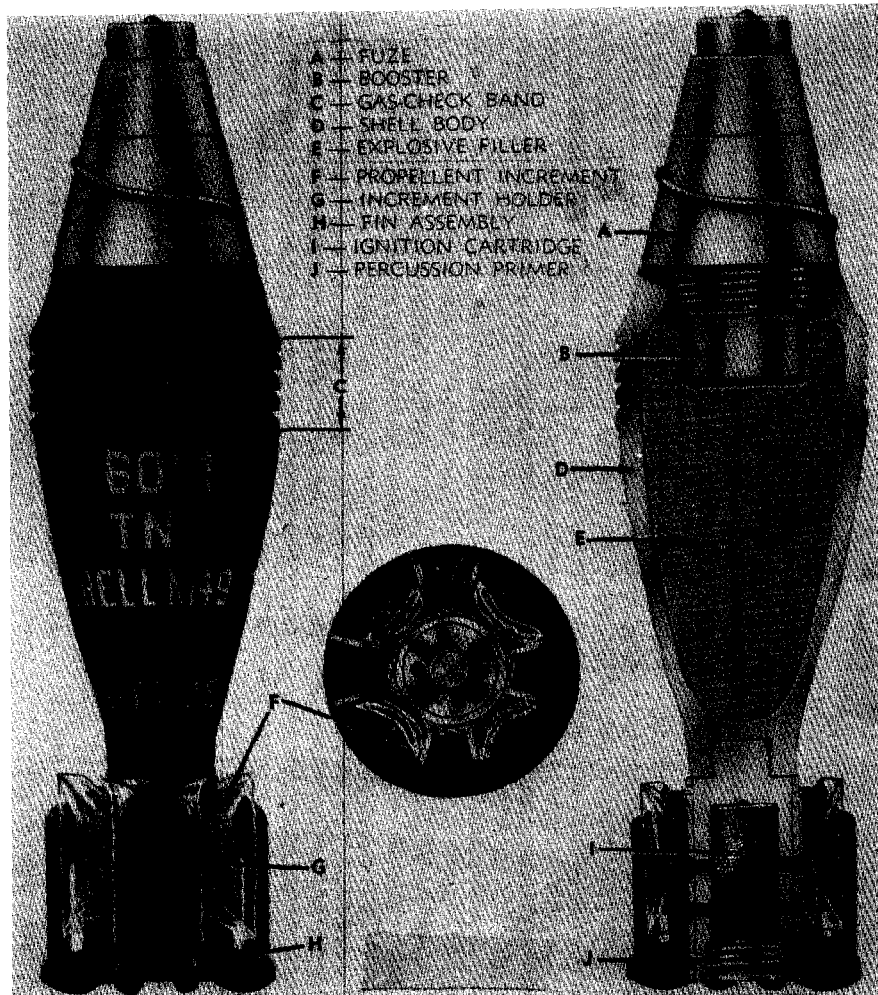

Fig 61 HIGH-EXPLOSIVE ROUND FOR 60-mm MORTAR

vents practically all gas from escaping past the projectile and provides a bearing surface for the round in its travel thru the bore. A "bore-riding pin spring" (See Fig 59) in the fuze of the mortar shell prevents the fuze from being armed until after it leaves the muzzle of the mortar. The projectile is stabilized in flight by fins. Its bursting charge is either TNT or Comp B and the fuze is PD (point-detonating) (Refs 17, 32, 41 & 52) (See Fig 61)

Primers and igniters for use in 81-mm Mortar Cartridges are of larger size and somewhat different in design. Several types are described in Ref 41, pp 85-8, and they are shown here in Fig 62

Primer Percussion M34 is similar to M32, except that its housing and head are of larger size. It is used in conjunction with *Ignition Cartridge M8*. This is similar to M5A1 (described under 60-mm Mortar Cartridge), except that the end closures consist of heavy chip-board washers with a thin paper disk cemented to one face. The faces are assembled adjacent to the propellant (No 9) charge in igniter (Ref 41, p 86)

Primer Percussion M71 is similar to M32 & M34, except for the exterior shape which facilitates assembling into the hub of the fin of the HE cartridge or smoke cartridge. Its head, body and firing plug are made from aluminum alloy, while the closing disk is

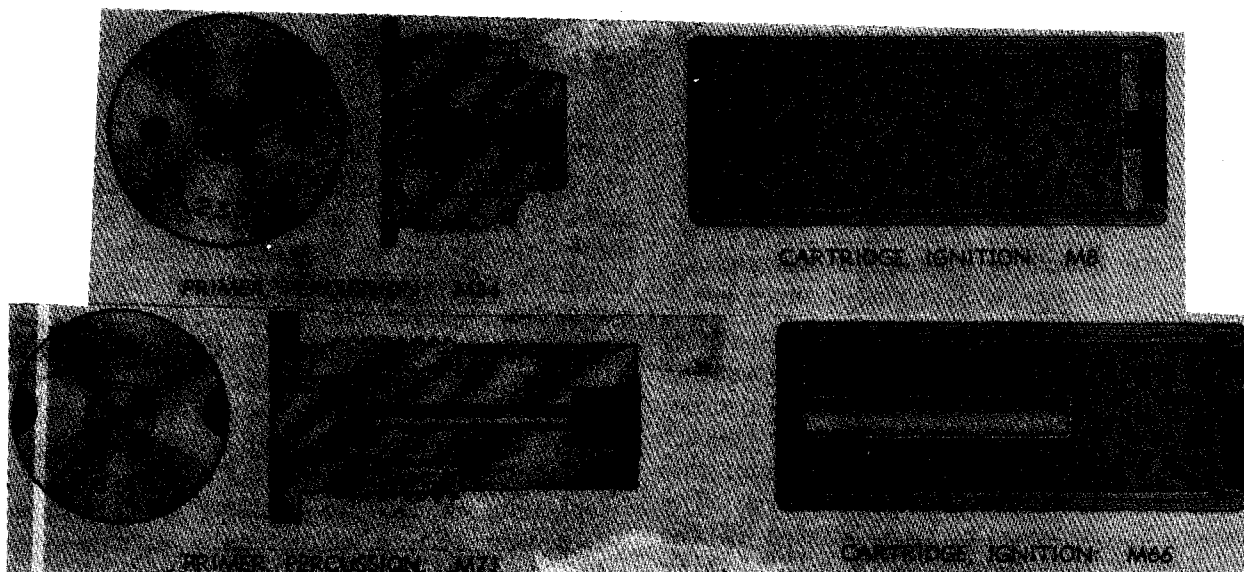

Fig 62 PRIMERS AND IGNITION CARTRIDGES FOR 81-mm MORTAR

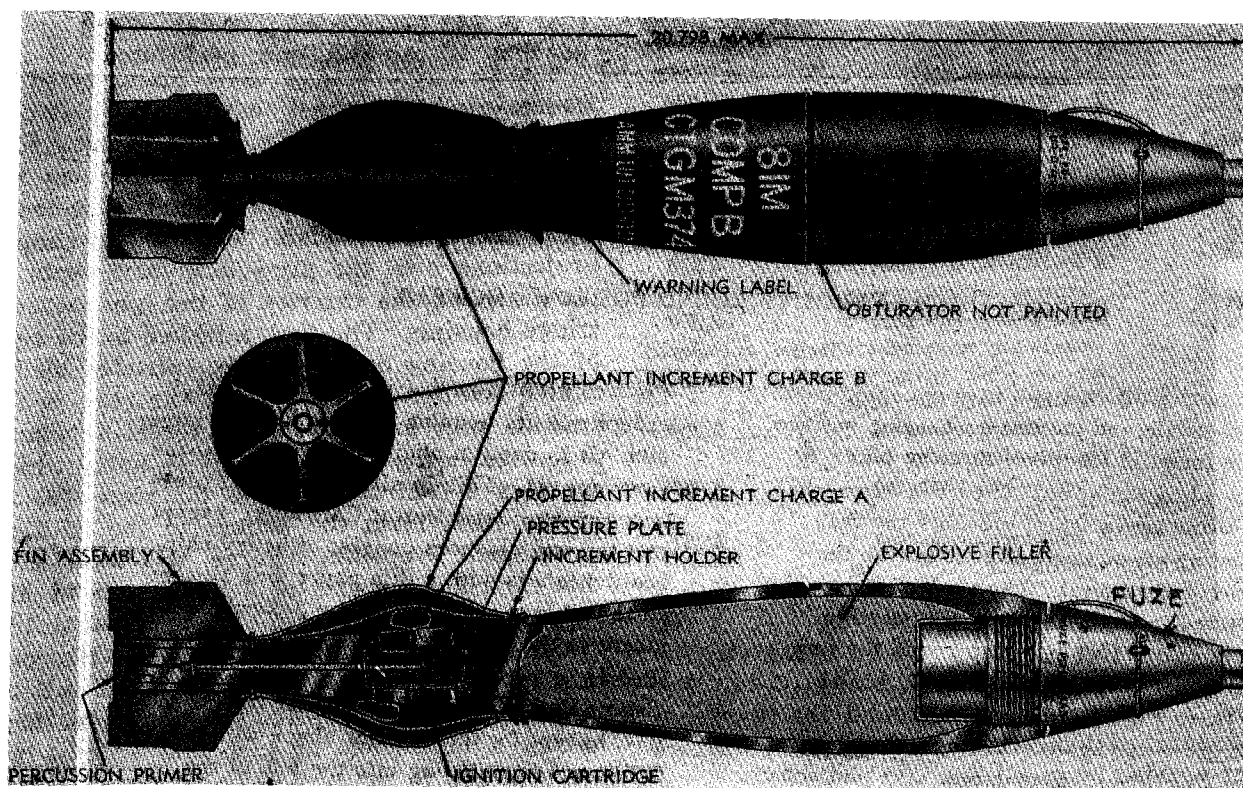

Fig 63 HIGH-EXPLOSIVE ROUND M374 FOR 81-mm MORTAR

made from gilding metal. The pellet consisting of 3.12 grains of BkPdr [See Vol 2 of Encycl, p B171-L (Ref 44)] and 0.37 grains of primer mixture (Ref 41, p 88). Primer M71 is usually employed in conjunction with *Ignition Cartridge M66*. It consists of a cylindrical body made of paraffined cartridge paper with the outer layer colored half red and half yellow. The inner layer is formed of two 0.005-inch thick brass liners to increase the confinement. The propelling chge of this cartridge consists of 115 grains of propellant M9 [See Vol 2, p C35, Table VI (Ref 44)]. The red colored portion of the cartridge contains a paper "flash" tube which extends approximately half the length of the cartridge body. The purpose of the paper flash tube is described under "Ignition Cartridge M5A1" used in 60-mm mortar ammunition. This side of the igniter is placed towards the primer or rear of the projectile (Ref 41, p 86). As an example of a round in which the above described primers and ignition cartridges are used may be cited the 81-mm HE Cartridge M374 (See Fig 63). Here the pearlitic malleable iron projectile, loaded with ca 2.10 lbs of Comp B, has the rear bourrelet section fitted with a polyvinyl chloride obturator ring with circumferential groove. Aluminum fin assembly consisting of an ignition cartridge housing and six extruded fins is assembled to the rear of projectile. The housing contains, besides the ignition cartridge, a pressure plate seated on the recessed shoulder just above the ignition cartridge. The perforations in the housing serve for transmitting the flash from the ignition cartridge to the propellant M9 increments. Steel increment holders with kidney-shaped projections hold the proplnt increments in place around the exterior of the ignition cartridge housing. The fins, attached to the rear of the housing, consist of six extruded blades canted counterwise 5° at the rear to introduce spin in flight. A percussion primer is located in the hub of the fin assembly which contains a central flashhole for transmission of the flash from the primer to the ignition cartridge. Propelling chge used in this round consists of

9 increments of flake proplnt, each confined in a water-repellant cotton cloth having a buttonhole at each end. Increment A contains 184 grains, while the eight other increments (B) contain 168 grains each. The bags are attached to the proj by engaging the buttonholes over the kidney-shaped holders. Increment A is assembled spirally underneath the other increments. Impact or proximity fuzes are used with this round. In firing, the round is dropped into the muzzle end of mortar so that the percussion primer can strike the stationary firing pin in the base cap of the mortar. The flash from burning primer compn is transmitted thru a tube to the ignition cartridge and this in turn, transmits flame to proplnt increments. The pressure created by gases on burning of ignition and proplnt chges forces the round out of the mortar tube. The projectile is fin-stabilized in flight (Refs 17, 32, 41 & 52). All smooth-bore mortars (60- & 81-mm) can be fired at any angle of elevation

Ohart (Ref 17, p 193), mentioned heavy, smooth-bore mortars of 105- and 155-mm and gave in Fig 97, p 193 a photo of 155-mm mortar complete round. There is no description in later publications, such as Refs 32, 41 & 52, of 105- and 155-mm rounds

The so-called *4.2-inch Mortar Cannon M30*, unlike 60- and 81-mm mortar, is rifle-bore and designed to fire at an elevation not higher than 60° . When using an HE round, the proj consists of a steel hollow cylindrical body filled with TNT and provided with a pressure plate at the base and with one of the desired type of fuzes, such as impact, mechanical time, mechanical time & superquick, or proximity. Three types of propelling chges are used: M6, M36 & M36A1. They are described in detail in Ref 52, p 4-42. The chges can be attached to the base of proj by different manners, which are represented in Fig 4-20, p 4-41 of Ref 52. The 4.2-inch Round M329 for Mortar M30 is shown here in Fig 64. Ignition cartridge M2 (Ref 41, p 86) is used with proplnt chges M6 & M36. [See Vol 2, p C34, Table V for compn of M6 proplnt (Ref 44)] and ignition cartridge B1A1 with proplnt chge M36A1. These ignition cart-

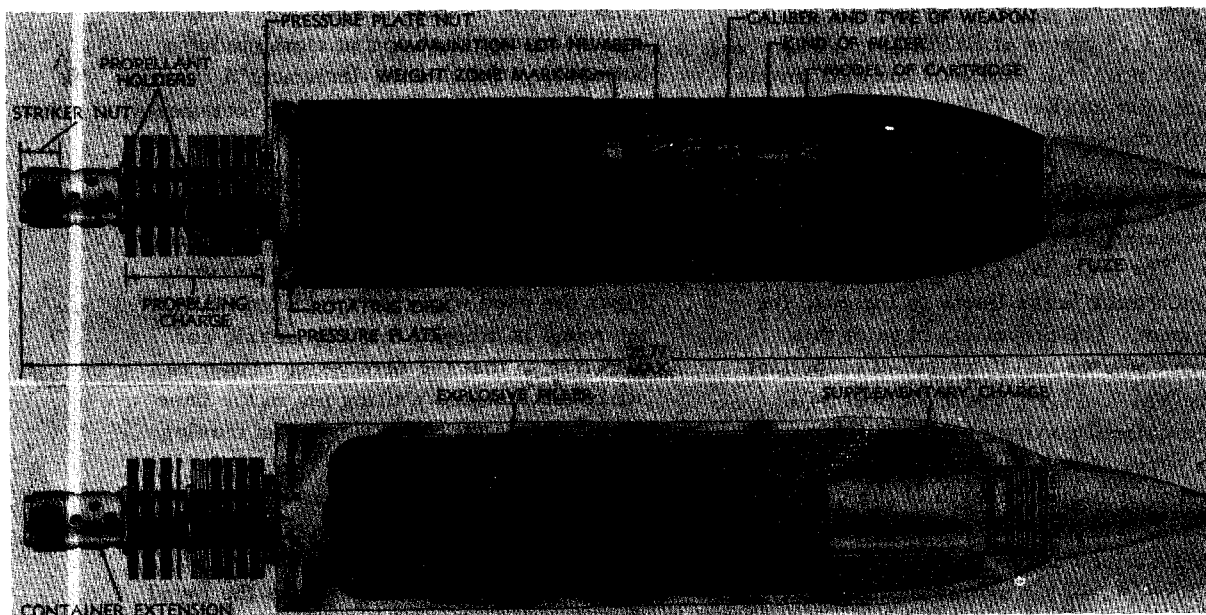

Fig 64 HIGH-EXPLOSIVE ROUND M329 FOR
4.2-inch MORTAR M30

ridges contain both the primer and the ignition charge in the same housing and are similar in appearance to a commercial 12-gauge shotgun cartridge [See Vol 2 of Encycl, Fig on p C73-L (Ref 44)], but are loaded with ca 120 grains of smokeless proplnt and contain no lead shot. The M2 ignition cartridge is 2.43 inches long and 0.808 inches in diameter (Ref 41, p 85). In the report of Rausch (Ref 31a, p 5) a small, poorly reproduced cut of this cartridge is given, but a clear fig of M2 percussion primer is given on p 8. It is reproduced here as Fig 65. The composition used in this primer consisted (up to 1956) of Basic Lead Styphnate 40, Ba nitrate 42, Sb trisulfide 11, NC 6 & Tetracene 1%. A soln contg 175g water, 3g gum arabic, and 3g gum tragacanth was used to wet each 8.38 lbs of this mixt before loading it in primers. This mixt was patented by a private firm. It is designated as K75 and described in Specification MIL-C-12927 (ORD)(1953)

As it was desirable to use a government-owned mixt for this primer, a research program was undertaken at PicArnsn. Because of similarity to K75 of government-owned No 60 mixt, developed at NOL (Naval Ordnance Lab),

it was decided to see if it could not be modified to be suitable for M2 primer. The original No 60 contained: Basic PbStyph 60, Ba nitrate 25, Sb sulfide 10 & Tetracene 5%. The mixt was modified so that wet loading techniques, generally used in the mass loading of percussion-type primers, could be employed. Modification involved the addn of either a gum arabic/gum tragacanth/water binder or a NC/elemi gum/organic solvent binder. These mixts were then loaded into M2 ignition cartridge primer metal parts and tested in comparison with primers loaded with K75, as described in the report. It was found that NOL No 60 with a gum arabic/gum tragacanth/water binder had sensitivity and output characteristics very similar to K75, while NOL No 60 with NC/elemi gum/org solvent did not perform in the M2 primer as K75 (Ref 31a, pp 1-2)

When a mortar proj with cartridge attached to its base is released it falls until the primer strikes the firing pin located in the center of its base. The flash from the primer ignites the chge in ignition cartridge, which, in turn ignites the propelling chge. The resulting gases exert pressure on the pressure plate at the base of the projectile (See our

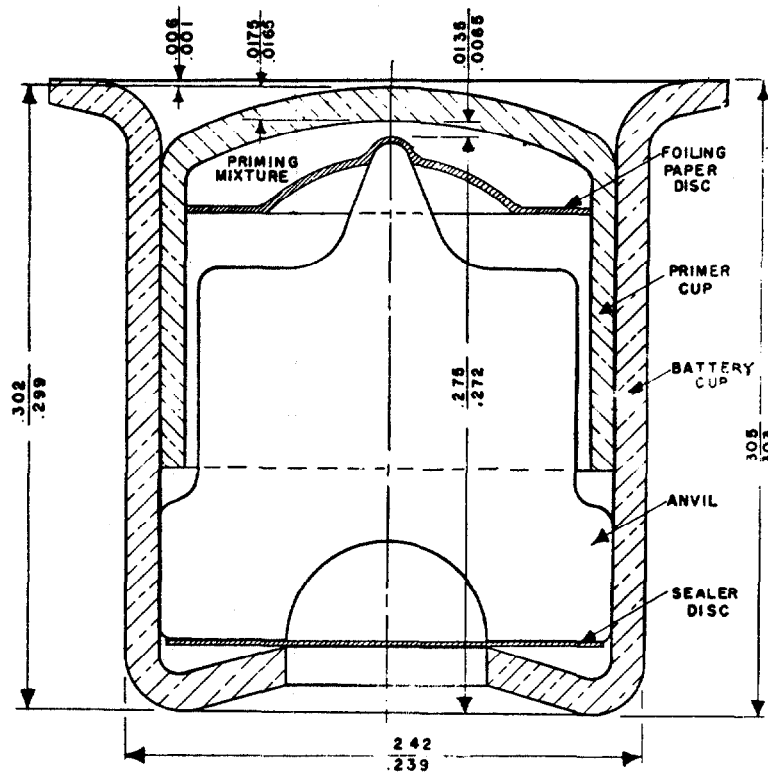

Fig 65 IGNITION CARTRIDGE PRIMER M2

Fig 64 for 4.2-inch Mortar Projectile, M329). This action expands the rotating disk, engaging it in the rifling of the mortar tube, and imparts spin to the proj as it leaves the muzzle in order to achieve stabilization in flight (Refs 17, 41 & 52)

Initiating components used in fuzes of artillery projectiles are described in Sections 4 & 5, while those used for bombs are described in Section 6

Section 3, Part E

Military Detonators (Except in Fuzes)

A *detonator*, in general, can be defined as a device intended to initiate by means of a detonating wave a high-explosive, such as used in military demolition devices or in land mines. Such devices when used for commercial explosives are known in US as *Blasting Caps* [See p B185 in Vol 2 of Encycl (Ref 44)], but in GtBritain they are called *Detonators*. The term "detonator" is often

reserved in US for devices used in fuzes and such detonators are described in Section 4, Part D

The term "detonator" has also been referred occasionally to devices used to destroy some ordnance items, but the term "Destructor, Explosive" is preferred [See Vol 3 of Encycl, p D92-R (Ref 48)]

Section 3, Part E

a) Detonators Used for Initiating Demolition Charges and Land Mines

The following "firing devices" used for initiation of land mines and demolition explosives are also known as "detonators" (Ref 30a, pp 50-4 Ref 32b, pp 121-27; and Ref 53, pp 34-9)

1) *Concussion Detonator M1, Delay Type* is a mechanical firing device actuated by the concussion wave of a nearby blast. It fires several charges simultaneously without connecting them by wires or detonating cord. A

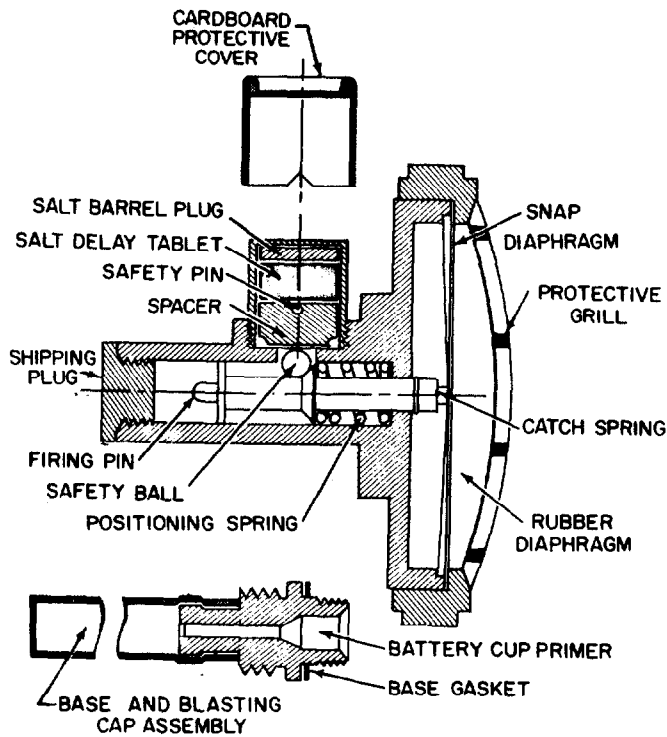

Fig 66 CONCUSSION DETONATOR M1, Delay Type

single charge fired in any way in water or air will detonate all charges primed with concussion detonators within range of the main charge or of each other. For example, for initiating charge of 2.5 lb, the range in air is ca 11 ft, for 10 lbs ca 16 ft and for 20 lbs ca 21 ft. For charge of 2.5 lb initiated in water at a depth of 2 ft, the range is 20 ft, while for a depth of 20 ft, the range is 150 ft. For charge of 20 lb initiated in water at a depth of 2 ft the range is 20 ft, while for a depth of 20 ft it extends to 260 ft. The detonator, shown in Fig 66, consists of a diaphragm-type-spring-loaded striker, restrained by a safety ball. The ball is held in place against the beveled shoulder of the striker by the spacer and the safety pin. When the pin is pulled, the positioning spring pushes the striker forward. This moves the safety ball and spacer upward, freeing the striker. A concussion wave strong enough to overcome the snap diaphragm causes the detonator to function.

2) *Friction Detonator, 8-Second Delay, M2* (Fig 67) consists of a cylindrical-shaped olive-drab plastic housing containing a pull wire coated with friction material. The wire is set in a flash compound. A tube set in the lower

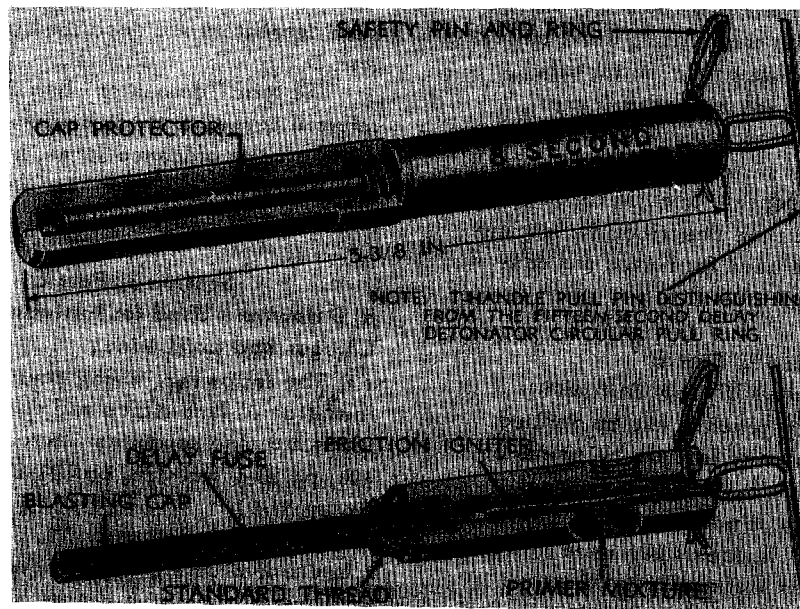

Fig 67-FRICTION DETONATOR M2, 8-second Delay

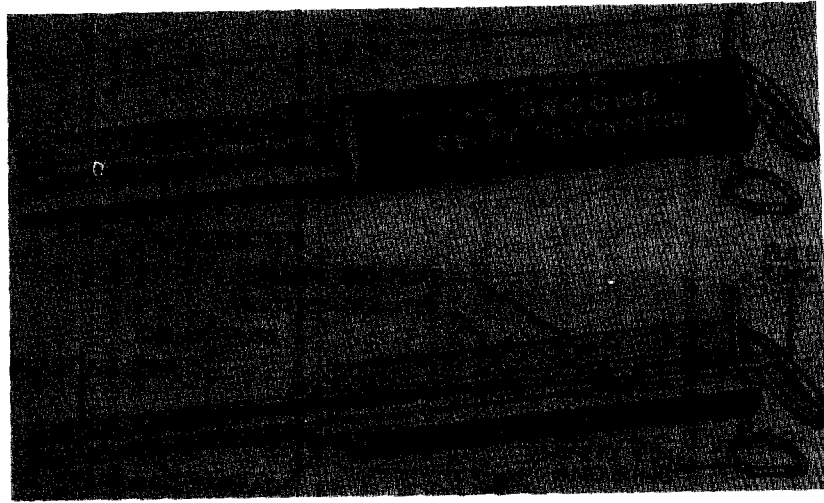

Fig 68 FRICTION DETONATOR M1, 15-second Delay

end of the housing contains an 8-sec time fuse and a blasting cap. The igniter is used to delay the firing of demolition chges particularly during assault demolitions. It is also used to fire underwater chges

For its functioning, remove the safety pin and pull the T-ring vigorously in order to draw the coated wire thru flash compn. This ignites the powder-train delay and about 8 seconds later the delay fuse explodes the blasting cap (Ref 30a, pp 47-8; and Ref 32b, pp 125-26)

3) *Friction Detonator, 15-Second Delay, M1* (Fig 68) is almost identical to the 8-sec delay detonator in overall appearance and functioning, except that its pull ring is circular and the powder-delay train is of 15-sec duration. (Ref 30a, pp 49-50 and Ref 32b, pp 126-27)

4) *Percussion Detonator, 15-Second Delay, M1A2 (M1E1)* (Fig 69) consists of a firing pin assembly joined to a delay housing and percussion primer holding assembly (Ref 53, pp 35 & 37, Fig 31)

Detonators used in fuzes are described in Section 4, Part D

Open literature information on detonators is listed here under Additional References, such as: Ad 1, Ad 27, Ad 31, Ad 41a, Ad 43, Ad 44, Ad 46, Ad 47, Ad 59, Ad 62, Ad 72, Ad 74, Ad 81, Ad 86, Ad 88, Ad-97c, Ad 105, Ad 114, Ad 115, Ad 132, Ad 135b, Ad 136, Ad 146 and Ad 160

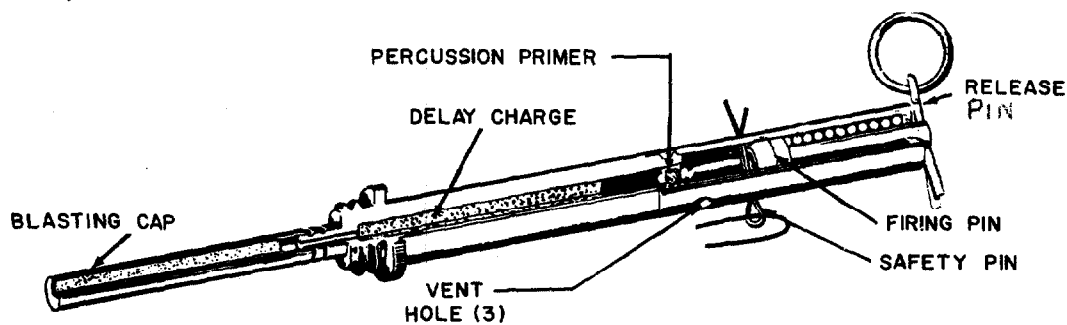

Fig 69 PERCUSSION DETONATOR M1A2 (M1E1)
15-second Delay

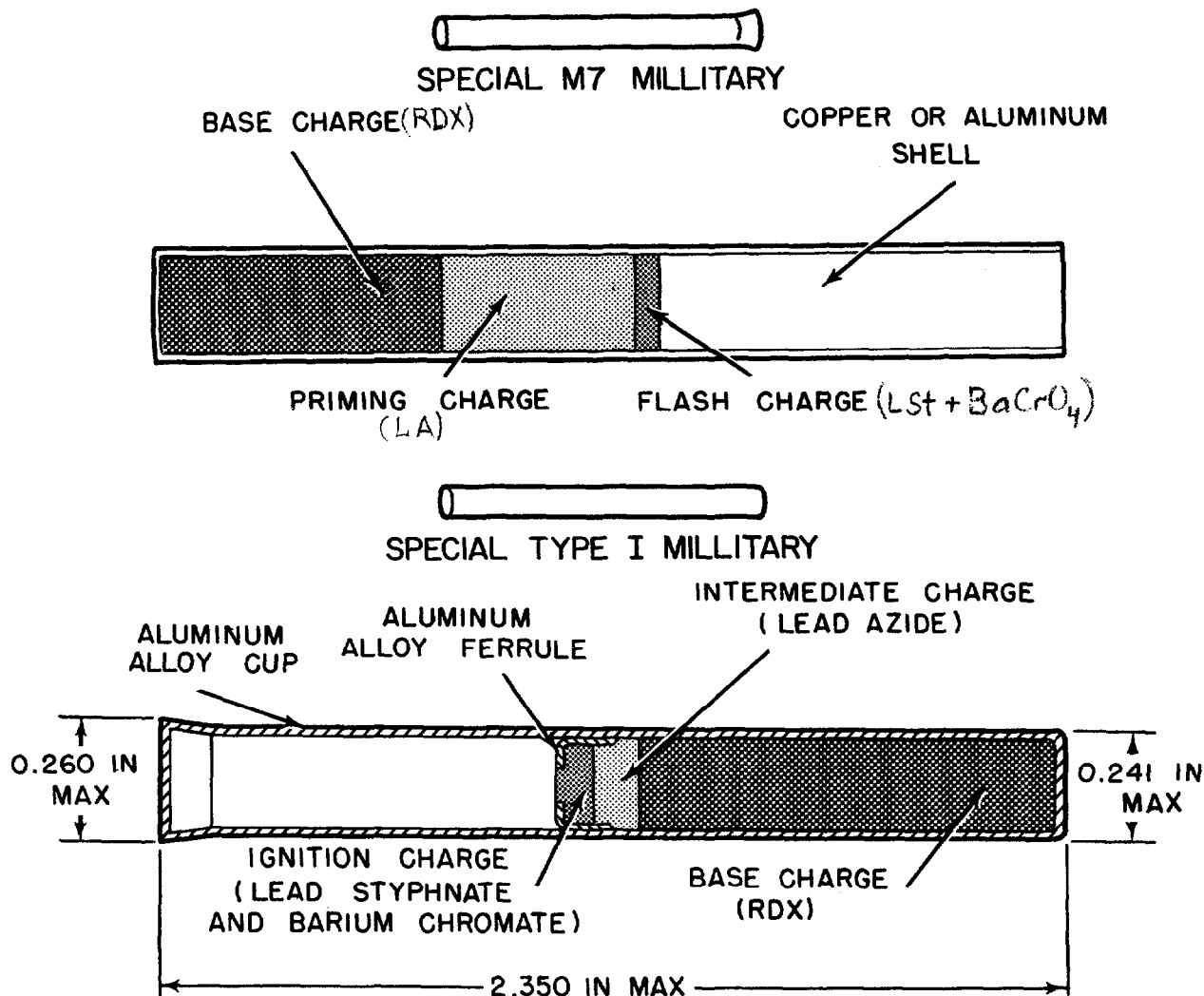

Fig 70 SPECIAL MILITARY NONELECTRIC CAPS

Section 3, Part E

b) Military Blasting Caps

We are including here a brief description and cutaway view of current US Military Blasting Caps, because they are actually "detonators". None of the drawings of Ref 53, pp 25 & 26 was given in Vol 2, p B188 of Encycl (Ref 44) for such caps, under BLASTING CAP. The description given on p B188 for nonelectric and electric caps does not seem to apply to the caps described in Ref 53 because the compositions of charges are not the same. The nonelectric special

military blasting caps **M7** and **Type I** shown in Fig 70, are charged with three layers: base or main charge (RDX), intermediate charge (LA), and flash or ignition charge (LSt + Ba chromate). They may be initiated by time blasting fuse, firing devices, and detonating cord. Unless moisture proofed, they cannot be used underwater or in wet bore holes. Commercial No 6 and No 8 caps may also be used for military purposes

The current "special electric blasting cap **M6**" described in Ref 53, pp 25-6 and shown here in Fig 71 is charged with the

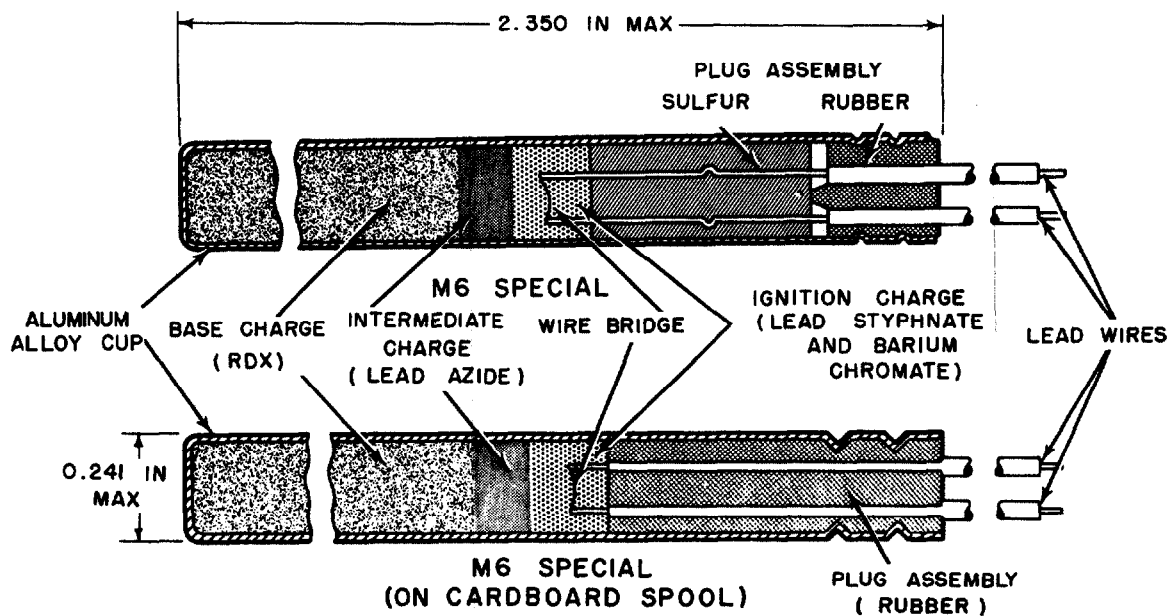

Fig 71 SPECIAL MILITARY ELECTRIC CAP M6

same ingredients as the nonelectric caps. They may be used when a source of electricity, such as blasting machine or battery are available. Some commercial electric caps, such as No 8, may also be used for military purposes

Section 3, Part E

c) Exploding Bridge-Wire (EBW) Detonators

Detonation by EBW devices was developed during and after WWII to replace the conventional low-energy electroexplosive devices in ordnance items. This was in order to avoid accidental firings which can be caused either by strong electromagnetic radiation environments or by stray voltage associated with modern weapons and space vehicle systems. It seems that one of the first applications of exploding wires to initiate explosives was done in 1938 by A.F. Belyaev. He used exploding wires to produce detonation of nitrogen chloride and NG and then applied this method to less sensitive expls, such as PETN or RDX which could not be directly initiated by heated wires, such as used in conventional electric detonators

When this method started to be investigated after WWII in USA, it was found that it had great possibilities. Not only could the electrical safety of detonators be improved but also the handling of sensitive primary expls could be eliminated

An EBW detonator could be similar in design to conventional low-energy electrical detonator, except that wires would be different and the expl charges would be HE's such as PETN or RDX without primary expls, such as LA, LSt, Tetracene, etc. Among the current US projects using EBW system, may be mentioned the Pershing & Polaris A-3 missiles and Saturn rocket (Ref 45)

Stresau et al (Ref 46d) describe the following types of EBW detonators:

Medium Energy EBW Detonator w/Wollaston Wire Bridge, shown in Fig 72. Wollaston wire is a coaxial bimetallic material made by inserting a wire of one material (usually gold or platinum) in a tube of another (usually silver) after which the combination of tube and core is drawn thru dies to a smaller size. The outer tube may be dissolved by an acid leaving the core, which may be much smaller than a wire could be drawn by any other process. High temperature double-bore thermo-

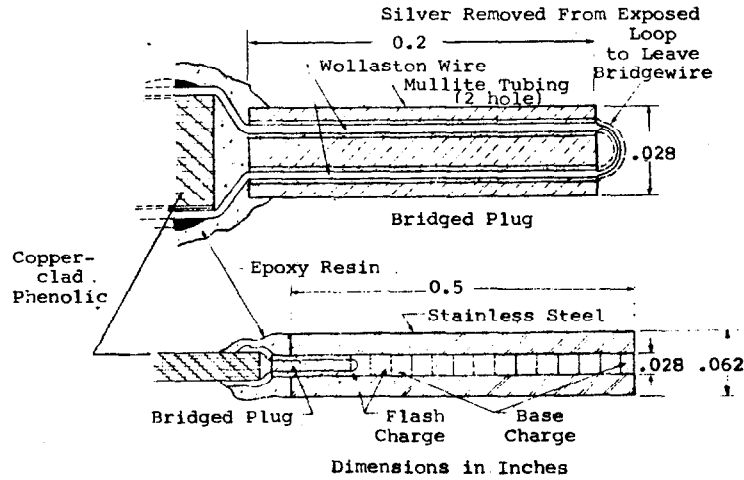

Fig 72 MEDIUM ENERGY EBW DETONATOR
W/WOLLASTON WIRE

couple insulating tubing made of Mullite (a refractory ceramic compound of alumina and silica) was used to house the wire, which formed a loop and the exposed loose ends of wire were soldered to the copper coating, of a copper-clad phenolic. A stainless steel tube was slipped over the tip, the ceramic tubing coated with epoxy resin cement, and the steel tubing slipped further to the shoulder formed by the bead. After the cement was cured at high temp, the loose end of stainless steel tube was loaded with flash and base charges, as shown at the bottom of Fig 72

The design shown in Fig 72 proved to be unsuitable for initiating expls less sensitive than RDX because they require higher voltages than can be achieved by the device shown. Such insensitive HE's are TNT and Ammonium Picrate. Modifications shown in Figs 73 and 74 proved to be more or less suitable for such expls

These less sensitive expls also made the design shown in Fig 75 even more suitable. In this detonator, the diameter of explosive column is in gradually increasing steps, because the charge diameters are so much

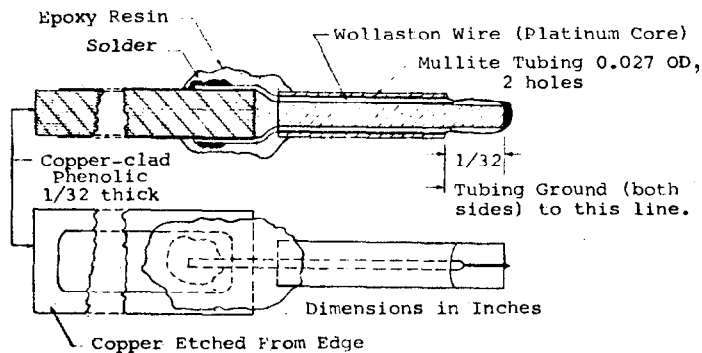

Fig 73 EBW PLUG (HV-1) MODIFIED FOR
VERY HIGH VOLTAGE

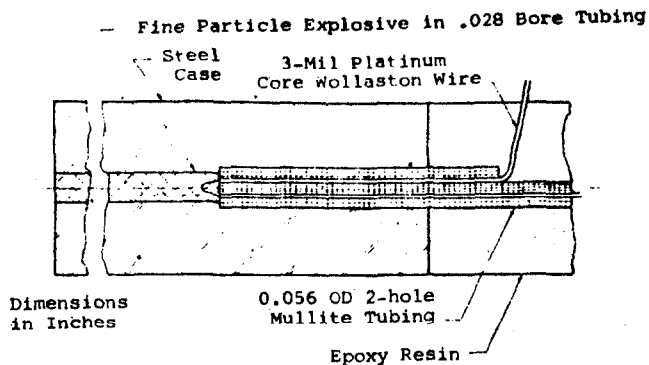

Fig 74 EBW DETONATOR DESIGN FOR HIGH VOLTAGE APPLICATION

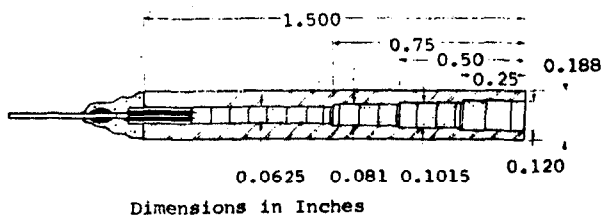

Fig 75 EBW DETONATOR WITH STEPWISE INCREASING BORE

smaller than the critical diameters for initiation of semi-infinite charges of these materials (Ref 46d, pp 450-52)

Three expls were used in experiments by Stresau et al: RDX, TNT and Ammonium Picrate. In their previous experiments it had been shown that the energy required to initiate RDX by EBW can be substantially reduced by the judicious use of confinement. Data given in their report demonstrated the applicability of this principle to less sensitive expls such as TNT & Ammonium Picrate. Practical implications of these results include: 1) the possibility of eliminating PETN (which is undesirable because of its sensitivity and relatively poor thermal stability) from EBW systems; 2) the possibility of reducing the bulk and weight of such systems; and 3) the possibility of developing EBW systems with very in-

sensitive expls, some of which are also stable at the high temps which are encountered in many modern weapon systems (Ref 46d, p 459)

Freiwald (Addnl Ref Ad 160, pp 496 & 497) gives (in our translation) the following brief discussion on EBW which is called "Explodirend Brückendraht" in German:

Investigations of direct electric ignition of secondary expls such as PETN and RDX were carried out for more than 15 years, especially with *exploding wires*, where thin wires were rapidly evaporated under formation of a shock wave, thru abrupt application of high electric energy produced for example by a capacitor (condenser) discharge

Recent publications on ignition of PETN with the aid of EBW indicate that the reaction time for detonation is reduced if the breakdown voltage at the capacitor is increased and the grain size of PETN or RDX is reduced. Furthermore, it has been shown that for initiation to detonation of PETN thru rapid discharge of $1\mu\text{F}$ capacitor, charged to 2000 volts, there exists an optional length of wire (different for each wire material) for which the energy density in wire and the lowest volume of expl are controlling factors. Suitable metals and alloys have been shown to be those which rapidly absorb energy and have low boiling points and low evaporating temperatures

In an early application of EBW, a non-compacted PETN was ignited by wires of Pt, W, & Cr-Ni alloy (with a thickness of $25\mu\text{m}$), at an energy of ca 0.5W . Remarkable was the fact that several detonators exploded nearly simultaneously, i.e. within a difference of microseconds

In later experiments, PETN was made electrically conductive by incorporating 10% of pulverized Zr. The resulting mixture was pressed at $280\text{kg}/\text{cm}^2$ and exploded by means of EBW. It required only $80\mu\text{W}$ at 1000V of capacitor, while a similar chge of PETN, but without Zr, required 0.5W at 9000V

There is also a description of the method proposed in USP 3062143 (1959) of Armor Research Foundation, where a detonator contg highly compressed mixt of PETN with 10%

of acetylene black is used

Additional information on EBW may be found in the following Addnl Refs Ad 97a, Ad 97b, 112a & 141

Section 4

ARTILLERY AND SOME OTHER PROJECTILES INCLUDING THEIR INITIATING COMPONENTS

Part A

Introduction

In Section 3 are described components used for initiating propellants in small arms ammunition and in artillery ammunition. Also included are some initiators for military demolitions and for pyrotechnic items. In order to understand more clearly the function of initiators in ammunition, cutaway views of complete rounds (which includes cartridges and projectiles) of "fixed" and "semi-fixed ammunition are given in Vol 1 of Encycl (Ref 43), p A385-L, under "AMMUNITION." Section 3 gives also description of initiation of propellant charges in mortars, together with cutaway views of 60-mm, 81-mm and 4.2-inch mortar rounds

Weapons used in artillery ammunition are briefly described in Vol 2 of Encycl (Ref 44), pp C26-L to C29-R under "CANNON"; while calibers of artillery ammunition are listed in Vol 1 of Encycl (Ref 43), pp A386-R to A387-R, under "AMMUNITIONS AND WEAPONS OR ARMS"

Section 4, Part B

Description of Various Projectiles

a) Projectiles Used in Cannons and Howitzers

As was mentioned above, projectiles used in fixed and "semifixed" ammunition are briefly described, together with cartridges in which they are used, in Section 3

Projectiles used in 120-mm rounds belong to the *separated type* of ammunition, while 155-mm and larger caliber projectiles are used in *separate-loading* ammunition, which is defined in Ref 43, p A385-L

As the term "separated ammunition" was not defined in Vols 1, 2 & 3 of this Encycl,

we are giving here its definition, as taken from Ref 52, p 2-2:

"In separated ammunition, the complete round consists of a plugged cartridge case and a projectile. Although the cartridge case and projectile are not assembled to each other, they are loaded into the weapon in one operation"

Before proceeding with description of detonators, and other items used in HE trains of projectiles, we are giving here brief descriptions of "Principal Parts of Projectiles"; "Types of Artillery Projectiles" and cutaway views of typical projectiles

Principal Parts of Artillery Projectiles
Body. The main section of the projectile is called the body. Body diameter represents diameter of the projectile between bourrelet and rotating band. To prevent contact with bare lands, body diameter is less than bourrelet or rotating band diameter (See also Ref 44, p B218-R)

Ogive. The curved portion from the projectile point to the bourrelet (the forward bourrelet, in the case of projectiles having fore and aft bourrelets) is called the ogive. A ballistic cap or windshield is employed (e.g., in the case of armor-piercing projectiles) as an ogive to improve ballistics (Ref 52, p 1-31)

Bourrelet. See Ref 44, p B258-R

Rotating band. The rotating band is a cylindrical ring of comparatively soft metal, or similar substance or of steel pressed into a knurled or roughened groove near the base of the projectile (or attached to the base of the projectile as in the 4.2-inch mortar). It affords a closure for the projectile in the forcing cone of the weapon in separate-loading projectiles and centers the rear end of the projectile in the bore of the weapon. In fixed ammunition the rotating band may not seat in the forcing cone until the instant of initial movement upon firing. As the projectile moves forward, the rotating band is engraved by the lands of the bore. Metal displaced during the engraving process flows into annular relief grooves or "cannelures" cut in the rotating band. In the case of 4.2-inch mortar shell,

NOTE: All References are listed in Section 7, pp D1023 to D1055

the rotating band is bell-shaped and is expanded into the grooves of the mortar rifling by the pressure of the propellant gases upon a pressure plate. Since the rifling of the weapon is helical, engagement with the band imparts rotation to the moving projectile. The rotating band also provides obturation, that is, prevents the escape of the propellant gases forward of the projectile by completely filling the grooves of the rifling. In the case of recoilless rifle projectiles, the rotating band is preengraved. Some projectiles may be provided with a double band (Ref 32, p 125)

Type of base. When the surface to the rear of the rotating band is tapered or conical, it is known as "boat-tailed"; when cylindrical, the projectile is described as having a "square base". Nonrotating mortar shells have fins at the rear for stabilization of the projectile (Ref 32, p 125)

Base plug. To facilitate manufacture, some armor-piercing projectiles are closed at the base with a steel plug. In the larger AP shot, the base plug also provides a seat for the fuze. In the smaller calibers, if an explosive charge is loaded in the cavity of the AP shot, the base plug is replaced by a base detonating fuze. In certain types of projectiles, the base plug may contain the tracer element (Ref 32, p 126)

Base cover. Each high-explosive shell is provided with a base cover to prevent the hot gases of the propelling charge from coming into contact with the explosive filler of the projectile thru joints or possible flaws in the metal of the base. The base cover consists of a thin metal disk, which may be caulked, crimped, or welded to the base of the shell. Projectiles with high-explosive filler and base detonating fuzes are not ordinarily provided with base covers, but have caulking or sealing rings. (Ref 32, p 126)

Tracer. For observation of fire, some projectiles are equipped with a tracer element in the base of the projectile. In most smaller-caliber antiaircraft shells, the tracer is used to ignite the filler and destroy the shell should it miss the target. Such a

tracer is called SD (self-destroying) (Ref 32, p 126 & Ref 52, p 1-31)

Closing plugs. In unfuzed fixed and semi-fixed ammunition, threaded plugs of steel or, more recently, of Al, protect against introduction of foreign matter into the fuze cavity during storage, shipment, and handling (Ref 52, p 1-31)

Lifting plugs. Separate-loading projs, issued and shipped unfuzed, are fitted with eyebolt-lifting plugs of the screw-in type. These plugs facilitate handling, in addition to protecting against introduction of foreign matter into the fuze cavity. In some gas projs, the eyebolt-lifting plug is fitted with a test connection for detection of gas leakage (Ref 52, p 1-31)

Fuze. See in Section 5 and Ref 52, p 1-30

Booster. See Ref 44, p B243-R and Ref 52, p 1-32

Burster. See Ref 44, p B364-L & Ref 52, pp 1-31 & 1-32

Bursting charge. See Ref 44, p B364-L and Ref 52, p 1-32

Artillery projectiles may be classified according to use as *service* (loaded with explosive, chemical or leaflets filler) and *training* (loaded with inert filler or no filler at all)

An artillery projectile may be either solid or hollow. Hollow projectiles may be filled with explosive or inert material, depending on the type. Artillery projectiles, although differing in characteristic details, are of the same general shape in that they have a cylindrical body and generally an ogival or conical head (or windshield). An exception is the canister projectile which has a blunt head. The projectiles vary in length from 2 to 11 calibers, that is, 2 to 11 times the diameter

a) *Normal-Cavity High-Explosive Projectiles.* The term "normal-cavity" as applied to high-explosive cartridge refers to the type of fuze cavity in the loaded projectile of the cartridge. The fuze cavity at the forward end of the projectile is only large enough to take the boosters used with mechanical-type point-detonating and time fuzes. The projectile body consists

of a hollow steel casing with boat-tailed base. The nose is formed to a long ogive and is threaded to receive standard contour fuzes. The fuze contour continues the long sweep of the projectile nose, maintaining a streamlined effect thruout

b) *Deep-Cavity High-Explosive Projectiles*. The deep-cavity projectile is identical with normal-cavity projectile described in *a* above, except for a deeper fuze cavity which makes the projectile adaptable for use with proximity fuzes or for mechanical-type fuzes and boosters with supplementary charge. For use with proximity fuzes, a deep fuze cavity at the forward end of the bursting charge is provided. Deep cavity projectiles contain an aluminum fuze well liner (some rounds on hand may have a cardboard liner), that also serves as a support for the HE filler. This liner is not to be removed. Insertion of a supplementary charge into the fuze cavity adapts the projectile for mechanical-type point fuzes and boosters. When deep-cavity projectiles are assembled with any authorized fuze, the data are the same as for the normal-cavity projectiles so fuzed. Deep-cavity projectiles may be shipped with closing plug (with or without supplementary charge) or with supplementary charge and mechanical-type fuze (Ref 40b, pp 9-10)

Types of Artillery Projectiles Service Projectiles

- 1) *High-Explosive (HE)*. Projectiles of this type, usually of forged or cold extruded steel and having comparatively thin walls and substantial HE burster charges, are used against personnel and materiel to produce blast or mining effect and fragmentation. According to action desired, this type is fitted with a time, impact, concrete-piercing, inertia or proximity (VT) fuze. To accommodate VT fuzes, HE projectiles usually have a deep fuze cavity lined with an aluminum cup to help support the HE filler. By placing a supplementary burster charge in the deep cavity, HE projectiles may be adapted for use with standard time or impact fuzes. In unfuzed projectiles, a tubular cardboard spacer is placed between the supplementary charge and closing plug. This is to prevent damage to the charge in shipment
- 2) *High-Explosive-Antitank (HEAT)*. This is a special HE type, the effect of which derives from its shaped charge. The metal cone which shapes the charge, stand-off (provided by projectile design), fuze action, and rotation affect depth of penetration. In high-velocity HEAT rounds, greater penetration is achieved with fin-stabilization and spin-compensation
- 3) *Armor-Piercing (AP or APC)*. Armor-piercing or armor-piercing-capped projectiles, of such materials as heat-treated, high-carbon alloy steel, are used to penetrate face-hardened armor
 - (a) The AP projectile has a hardened steel head for penetration of armor, and a tough body to withstand the strain of impact and the twist of the projectile at high angles of obliquity. A steel or aluminum windshield is generally attached to the projectile body to increase ballistic efficiency
 - (b) The APC projectile has a cap of forged alloy steel, heat treated to have a hard exterior and a relatively soft core. The softer core protects the hardened point by distributing impact stress, as a result of which the cap can defeat armor. Some APC rounds contain a small charge of Explosive D and are fuzed with BD fuzes. The base plug or the base end of the fuze may contain a tracer
- 4) *Hypervelocity Armor-Piercing (HVAP)*. This projectile consists of a core of an extremely hard high-density material, usually tungsten carbide, within a lightweight carrier, usually aluminum. The carrier has a skirted base, threaded to receive a tracer, and is fitted with a rotating band and forward bourrelet. An armor-piercing cap similar to that used on APC ammunition may be placed on the core. The use of this lighter projectile enables velocities above 3500fps

- (hypervelocities) to be obtained without exceeding the allowable pressure of guns designed for lower muzzle velocities and heavier projectile. The carrier does not assist materially in penetrating the target, since it breaks up completely or vaporizes when it hits, leaving the core to penetrate the target by kinetic energy
- 5) *Armor-Piercing Discarding Sabot (APDS)*. In this type of projectile, a carbide core, either capped or uncapped, is placed inside a steel or light-alloy sheath (fitted with a tracer) to give good exterior ballistic characteristics, and this sub-caliber assembly is placed inside a full-caliber carrier. This carrier (sabot) is so designed that it will impart velocity and spin to the subcaliber projectile. The sabot, usually made of aluminum, magnesium-zirconium alloy or plastic, may be released from the subprojectile by a device actuated by setback, propellant-gas pressure, or centrifugal force. The sabot, because of its poor ballistic shape and its low mass, loses velocity rapidly and leaves the subprojectile free shortly after it leaves the gun. Velocities in the 4800fps range have been obtained with this projectile. The core of the subprojectile penetrates the target by kinetic energy
- 6) *High-Explosive Plastic (HEP)*. Description and functioning of this ammunition is classified. See TM 9-1300-203-1 for coverage
- 7) *Antipersonnel (APERS)*. This projectile is intended for antipersonnel use at both close and long range. It is made of steel and/or aluminum and consists of a base (with tracer and rotating band), a body, an explosively loaded fuze adapter, and a mechanical time fuze. The projectile is loaded with steel flechettes (fin stabilized fragments), an expelling charge and a spotting charge. When the fuze functions, the explosives in the fuze adapter are detonated. This rips open the forward end of the body and ignites the expelling charge. The payload of flechettes is dispersed in a conical pattern by centrifugal force and the gas pressure built up by the burning expelling charge. The spotting charge is also released, marking the point of payload dispersion
- 8) *Canister*. This projectile is intended for anti-personnel use at close range. The projectile consists of a heavy steel base with integral rotating band, and a thin steel body loaded with a payload of steel flechettes (fin stabilized fragments), steel slugs, or ball bearings, which are held in place by a closing cup attached to the forward end of the body. The body has four axially-oriented slots or grooves for about one-half to three-fourths of its length. Immediately after the projectile leaves the muzzle of the gun, air pressure on the closing cup and centrifugal force acting on the body and payload cause the projectile to break at the slots or grooves on the body, with resultant conical dispersion of the payload (Compare with Ref 44, p C24-R)
- 9) *Illuminating*. This type of projectile is used to illuminate a target area under conditions of reduced visibility. The projectile is hollow and contains a payload consisting of a parachute and illuminant assembly. The illuminant is ignited and the parachute and illuminant assembly are ejected from the projectile by an expelling charge adjacent to a time fuze. The parachute and burning illuminant assembly slowly descend, lighting the target area
- 10) *Chemical*
- (a) *Bursting type*. These projectiles are similar in external appearance to HE projectiles and have similar ballistic properties. The steel projectile has a centrally oriented burster tube containing an explosive burster and is fitted with a mechanical time fuze. The projectile is loaded with persistent or nonpersistent gas or with white phosphorus. When the fuze functions, the burster is detona-

ted. This ruptures the projectile body and disperses the chemical filler

- (b) *Base ejection type*. These projectiles are the base ejection type containing a payload of canisters generally loaded with colored smoke composition. The projectile is assembled with a mechanical time fuze, an expelling charge and a threaded base plug. When the fuze functions, the expelling charge is ignited. This in turn ignites and expells the canisters and base plug from the projectile. The burning canisters produce a smoke cloud for screening and spotting purposes

- 11) *Leaflet (L)*. This proj is similar to the base-ejecting chemical proj described in paragraph (10)(b) above, except for the payload. The proj is loaded with leaflets for propaganda purposes

Training Projectiles

- 1) *Target Practice (TP)*. This proj simulates the ballistic properties of service projs and is used for training in marksmanship. It may be made from completely inert-loaded service projs, or made from different metal parts and may contain a tracer and/or a spotting charge of BkPdr (Ref 52, p 1-33 & 1-34). Some TP projectiles used to be empty cast-iron shells (Ref 40b, p 4)

- 2) *Projectile Simulators*. Airburst and ground-burst simulators are used in connection with artillery training. They are actually pyrotechnic items as they contain pyrotechnic compns (Ref 40b, p 4). Various types of simulators are described in Ref 51c, pp 5-13 to 5-18
- 3) *Dummy projectiles*. are used for training in handling and loading ("service of the piece"). They are completely inert (Ref 40b, p 4)
- 4) *Blank Ammunition* consists of a cartridge contg a small amt of an explosive, such as BkPdr to produce a loud report for saluting or training purposes. It has no projectile (Ref 40b, p 4)

Following are cutaway views and brief descriptions of typical US artillery projectiles with indications of their uses in various caliber weapons

Typical HE (High-Explosive) Projectile w/o Tracer, is shown on Fig 1-1. Its body, made of forged steel, is provided with a long ogive and a square near which a gilding metal rotating band is fitted. A PD fuze is inserted into the threaded opening of the body

A projectile used in 120-mm HE, *Comp B, M356 (T15A1) Separated Round* has a base similar to that shown in Fig 1-2 (minus tracer) and two gilding metal bands instead of one. As a filler this projectile uses 7.84 lb of Comp B, but some older models of 120-mm projectiles contained TNT. The projectile

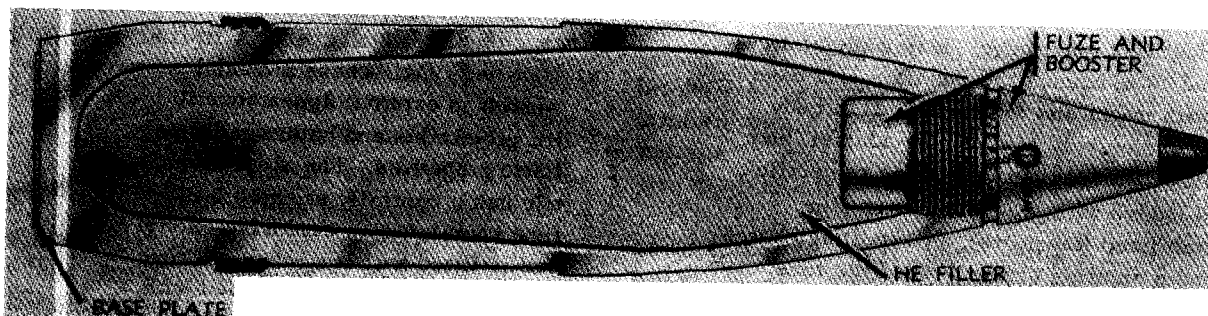

Fig 1-1 TYPICAL HE (HIGH-EXPLOSIVE)
PROJECTILE W/O TRACER

is propelled by gases formed on deflagration of 24 lb of single-base, multiperforated propellant M6 in a cloth bag. The compn of this and of other military proplnts are given in Vol 2 of Encycl (Ref 44), p C34, Table. The cartridge case is fitted at its base with primer M28B2, which does not require an igniter of BkPdr. The open end of case is fitted with a closing plug cemented in place. Length of cartridge is 34.75 inches, length of fuzed projectile 23.19 in, muzzle velocity 2500fps and maximum range 19910 yds. When assembled PDCP (point-detonating, concrete-piercing fuze) M78 or M78A1, the proj will pierce concrete, destroy reinforcing bars, etc (Ref 40b, pp 81 & 166 and Ref 52, pp 2-77 & 2-78)

This type of HE projectile has been used in the following separate-loading ammunition: 155-mm HE, M101 for Gun Cannons (Ref 52, pp 2-86 & 2-87); 155-mm HE, Comp B and TNT, M107 for Howitzer Cannons (Ref 52, p 2-131); 175-mm HE, M437A2 for Howitzer Cannons (Ref 52, p 2-100); 8-inch HE, M106 for Howitzers (Ref 52, p 2-144); and 280-mm M124 & M124A1 for Gun Cannons (Ref 52, pp 2-102 & 2-103)

This type has also been used in the following fixed and semifixed ammunition: 57-mm HE, M306 Series for Recoilless Rifles (Ref 52, pp 3-5 & 3-6); 60-mm HE, M49 Series for Mortars (Ref 52, pp 4-4 to 4-6); 75-mm HE, M48 Series for Gun Cannons (Ref 52, pp 2-25 to 2-28); 75-mm HE, TNT, M334

(T50E2) for Gun Cannons (Ref 52, p 2-36); 75-mm HE, Comp B, M334 (T50E2) for Gun Cannons (Ref 52, p 2-37); 75-mm HE, M73 for Gun Cannons (Ref 52, p 2-74); 75-mm HE, M48 for Pack Howitzers (Ref 52, p 2-104); 77-mm HE, M309 Series for Recoilless Rifles (Ref 52, pp 3-12 & 3-13); 76-mm HE, Comp B, M352 for Gun Cannons (Ref 52, pp 2-39); 81-mm HE, M43 Series, M56 Series, M362 Series & M374 for Mortars (Ref 52, pp 4-18 to 4-27); 90-mm HE, M71 for Gun Cannons (Ref 52, p 2-57); 90-mm HE, XM590E1 for Recoilless Rifles (Ref 52, p 3-20); 105-mm HE, M1 for Howitzer Cannons (Ref 52, p 2-115); 105-mm HE, M323(T42) for Recoilless Rifles (Ref 52, p 3-24); 4.2-inch HE, M3 Series and M329 Series for Mortars (Ref 52, pp 4-43 to 4-45)

Typical HE-T (High-Explosive-Tracer) Artillery Projectile, such as used in 120-mm HE-T, Comp B, M356 (T15E3) Separated Ammunition is shown in Fig 1-2. It consists of a forged steel body loaded with 7.84 lb of Composition B and fitted with a PD fuze. The exterior of the body, near the base, has two gilding metal rotating bands and a boss with tracer in the center of the base. Overall length of projectile is 24.02 inches, muzzle velocity is 2500fps and maximum range 19910 yds. The "separated" brass cartridge case M109 contains 12.4-lb of triple-base proplnt M15 (See Table on p C34 of Ref 44), in a silk bag which has an axial opening to accommodate primer M67 (T85E3). Some rounds

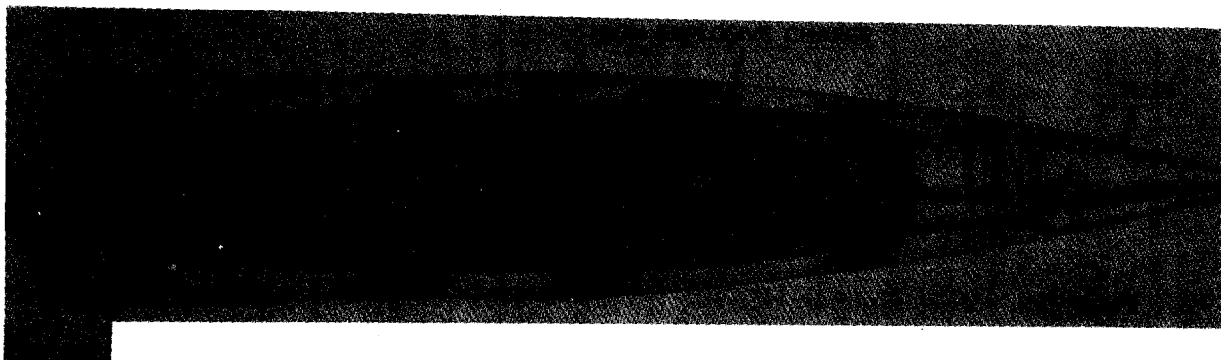

Fig 1-2 TYPICAL HE-T (HIGH-EXPLOSIVE-TRACER) PROJECTILE

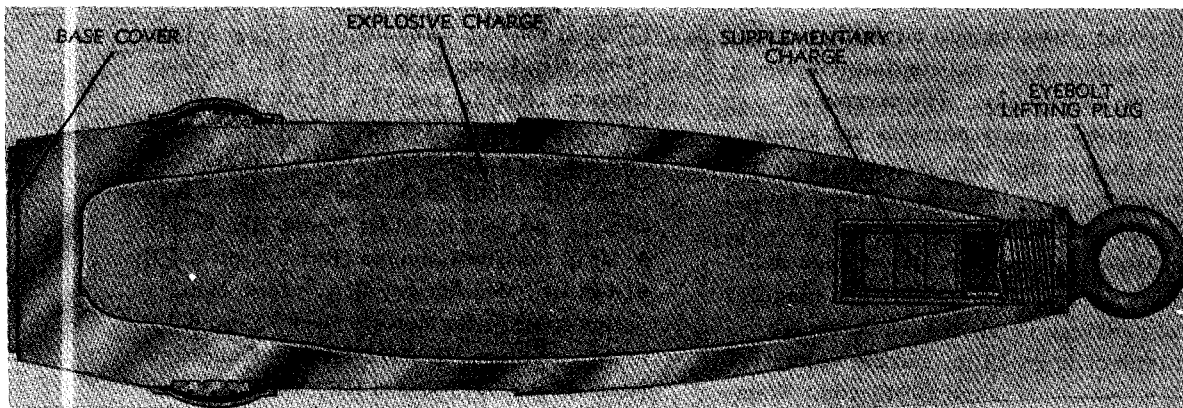

Fig 1-3 TYPICAL HE PROJECTILE W/SUPL CHARGE

of earlier manuf contained loose proplnt held in the cartridge case by distance wadding to which a supplementary igniter was attached. The tracer is ignited by the proplnt to burn for a minimum of 3 secs (Ref 40b, pp 82 & 166; Ref 52 & Appendix, pp 2-76 & 2-77)

This type of projectile has been used in the following fixed ammunition: 37-mm HE-T, SD M54 & M54A1 for Automatic Guns (Ref 52, pp 2-7 to 2-9); 40-mm HE-T, SD MK11, SD MK2, SD M3 & SD M3A1 for Gun Cannons (Ref 52, pp 2-16 to 2-19); 90-mm HE-T, M71A1 for Gun Cannons (Ref 52, p 2-57); and 90-mm HE-T, M91 for Gun Cannons (Ref 52, p 2-58)

Typical HE Projectile with Supplementary Charge, shown in Fig 1-3, has been used in one of the "separated" rounds, the 120-mm HE, M73 w/Suppl Chge for Gun Cannons (Ref 52, p 2-75) and in several "separate-loading" rounds, which are described below:

155-mm HE, M101 Projectile w/Suppl Chge, used in gun cannons, consists of a forged-steel shell loaded with 15.48-lb of cast TNT. A deep fuze cavity at the nose of the body contains a supplementary charge of 0.30-lb of TNT in an Al liner. The design of the fuze cavity and the presence of the supplementary chge render the proj suitable for use with any of the three fuzes: VT (proximity), PD (point-detonating) or MT (mechanical time). A single rotating band (protected by a grommet during storage and handling) encircles the proj ca 3.5 inches

forward of the boat-tailed base. The proj is issued unfuzed with an eyebolt lifting plug threaded in the point. Overall length of proj is 26.81 in and total wt 95.73 lb. When the proj is fitted with a PD or MT fuze, the functioning of the fuze detonates the supplementary chge, which, in turn, detonates the main chge of proj. With a VT fuze the main chge is detonated directly by the functioning of the fuze. Propelling chge for 155-mm separate-loading gun cannon ammunition is shown in Fig 55, while chges M3 and M4A1 used in 155-mm howitzer cannons are shown in Figs given on p C76-L of Vol 2 of Encycl (Ref 44). Larger and clearer Figs of M3 and M4A1 proplnt chges are shown in Ref 52, p 2-126. When proj is fired from gun cannons MT or M46, the muzzle velocity is 2800fps and maximum range 2571 yds (Ref 52, pp 2-91 & 2-92)

Similar in appearance and in function are 155-mm HE, M107 Projectile w/Suppl Chge for use in howitzer cannons (Ref 52, pp 2-130 & 2-131) and 8-inch HE, M106 Projectile w/Suppl Chge for use in howitzer cannons (Ref 52, p 2-144)

More streamlined in appearance are 175-mm and 280-mm projectiles, shown here in Figs 1-4a and 1-5a, respectively

175-mm HE Projectile M437A2 w/Suppl Charge, used for fragmentation, blast or mining, is more streamlined in appearance than 155-mm and 8-inch projectiles. Its cutaway view is given in Fig 4a and its

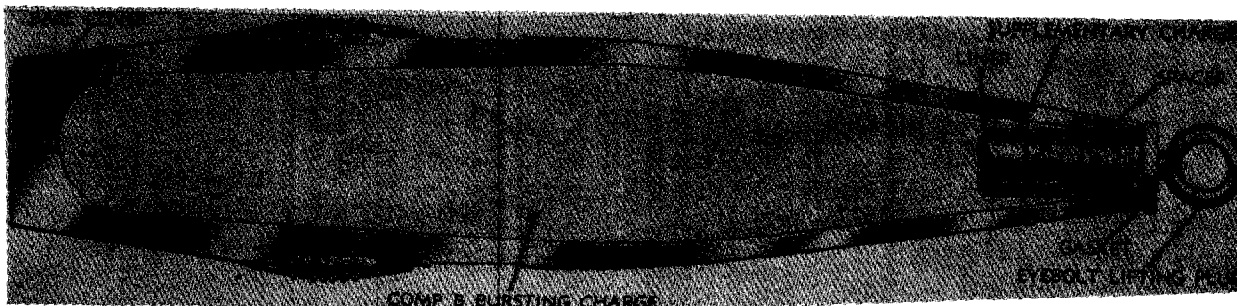

Fig 1-4a 175-mm HE, M437A2 PROJECTILE WITH SUPPLEMENTARY CHARGE



Fig 1-4b 175-mm PROPELLING CHARGE M86A1

separate-loading propelling charge M86A1 is shown in Fig 1-4b. The projectile, 37.23 inches long, is filled with 31.0 lb of Comp B and contains a supplementary chge of 0.30 lb of TNT. Total wt of fuzed proj is 147-lb. (The supplementary charge is used when the round is fired with a conventional fuze; it is removed when firing with a proximity fuze). A gilding metal rotating band encircles the steel projectile approximately eight inches from the base, and a nylon obturating band is located 0.2-inch behind the rotating band. A heavy steel cover is welded to the projectile base to aid in preventing hot propelling gases from entering the projectile body. The propelling chge used in this round consists of three increments. Each of them is ca 49.5 inches long and contains a total of 55 lb of M6 multiperforated propellant in acrylic viscose rayon bags. The bags are tied together by four tying straps attached to the top of increment No 1 and knotted on top of increment No 3. The tying straps are reinforced by cord tied tightly around the junction of increments Nos 2 and 3. Each propelling charge has an igniter core assem-

bly extending thru the center of the charge. The core assembly consists of three rigid polyurethane tubes with bell-shaped connections containing bagged igniter charges of BkPdr. In addition, a red cloth igniter pad, also filled with BkPdr, is attached to the base of increment No 1. During shipment and storage, an igniter protector cap is placed over the igniter

Percussion primer M82 is used with this ammunition. It consists of a primer body contg a percuss ignition element and a primer chge of BkPdr in a closed container (See Fig 57)

When the weapon is fired, the percussion primer, activated by the firing mechanism, ignites the base pad of the propelling charge. The burning base pad ignites the BkPdr charges in the core assembly, producing sparks and flame which flash through the perforations in the igniter core tubes to ignite the propellant. (The arrangement of the perforated tubes assures uniform ignition of the propellant increments). When the round is fired at full charge, an additive jacket is assembled to increment No 3 to reduce bore-

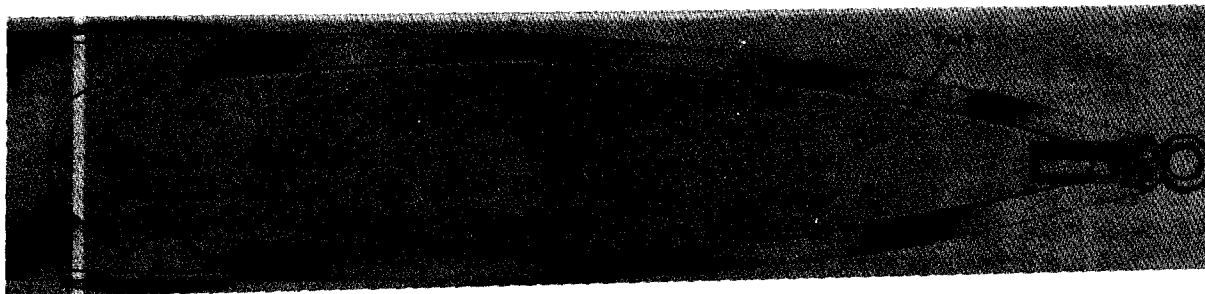

Fig 1-5a 280-mm HE PROJECTILE M124(T122E4)
W/SUPPL CHARGE

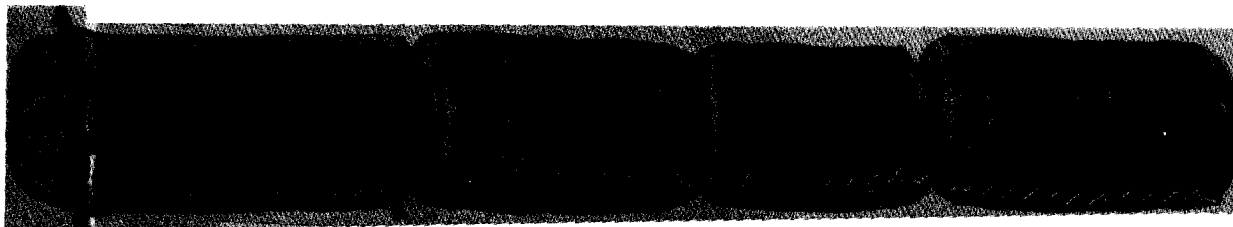

Fig 1-5b 280-mm PROPELLING CHARGE M43

wear in the weapon. Gases generated by the burning propellant force the spin-stabilized projectile out of the gun tube and propel it to the target. The obturator band, which seals the propellant gases behind the projectile, is discarded when the projectile leaves the weapon. Depending on the type of fuze employed (proximity or point-detonating), the expl chge is detonated either in flight or on impact. Its muzzle velocities and maximum ranges are: for zone 1 - 1675fps & 16504 yds, respectively; for zone 2 - 2310fps & 24155 yds and for zone 3 - 3000fps & 35740 yds (Ref 52 and its Appendix, pp 2-100 to 2-103)

280-mm HE Projectile M124 (T122E4) w/Suppl Charge, shown in Fig 1-5a, differs slightly in appearance from 175-mm projectile of Fig 1-4. The proj is designed to be fired from Gun Cannon M66 which is used as a mobile, long range, heavy artillery weapon. It is operated as a fixed mount, but is strategically mobile when the gun tube is retracted and the carriage is loaded on heavy artillery transport T10. The projectile made of a one-piece steel forging is the "deep cavity" type and contains 101.7 lb of cast TNT and a

supplementary chge of 0.3 lb of pressed TNT. The projectile may be assembled with fuzes; MTSQ (Mechanical Time Superquick), PD (Point Detonating), VT (Variable Time or Proximity) or CP (Concrete-Piercing M78 or M78A1). Length of fuzed proj is 52.43 inches and total wt 600.0 lb. The propelling chge used for firing the projectile is shown in Fig 1-5b. The chge, designed for zone firing, consists of four increments (a base chge, two approx equal increments and one odd-sized increment) of dualgran propellant M6 (See Ref 48, p C-354, Table V). The full chge weighs 158 lb, which permits the achieving of a muzzle velocity of 2500fps and a range of 31400 yds. Combination electric and percussion primer MK15 Mods 1, 2 or 3 are used with this proplnt chge. This breechblock-type primer, shown in Fig 54, consists of a plunger, a primer cap (contg a sensitive primer compn), an igniter cup (loaded with an igniter chge & contg a resistance wire insulated with Guncotton), and a primer cup (contg 30 grains of BkPdr)

When the weapon is fired, the primer is initiated, igniting the proplnt. Gases created by its burning, force the spin-stabilized pro-

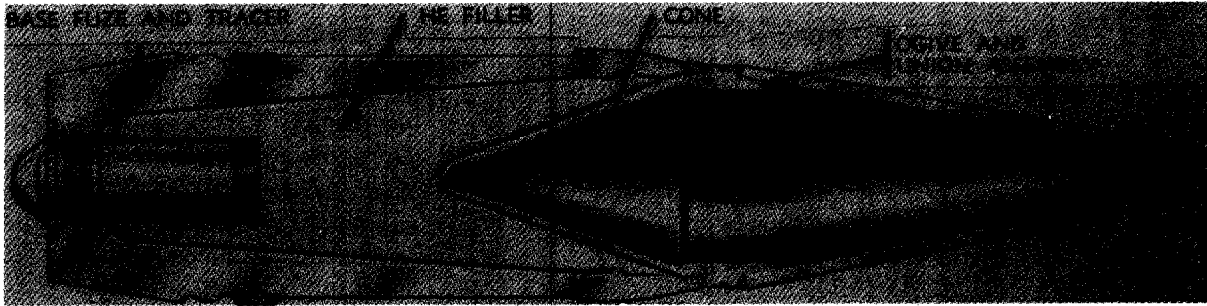

Fig 1-6 TYPICAL HEAT-T (HIGH-EXPLOSIVE, ANTI-TANK-TRACER) PROJECTILE

jectile out of the gun tube and propel it to the target. Then the TNT filler detonates causing the fragmentation of projectile (Ref 40b, pp 101-103 & Ref 52 & Appendix, pp 2-102 & 2-103)

The M123A1 (T122E3) proj differs from the M124 in that the proj body is made of cast steel instead of forged steel (Ref 52, p 2-103)

Typical HEAT-T (High-Explosive, Antitank-Tracer) Artillery Projectile, shown in Fig 1-6, consists of a forged-steel body contg a shaped HE charge (such as cast Comp B) covered at its cavity with a Cu cone. An ogive is attached to the forward end of the body and a base fuze with a tracer is inserted into a threaded opening at the base of the body

On impact with a target, the fuze functions thus detonating the HE filler. This causes creation of high-velocity shock wave and collapse of Cu lining of the cone. Then, highly disintegrated metal particles travelling at super-velocity speed penetrates thru the target (Ref 52, pp 1-17 & 1-33)

This type of projectile has been used in 57-mm HEAT-T, M307A1 for Recoilless Rifles (Ref 52, p 3-6); 75-mm HEAT-T, M66 for Pack Howitzers (Ref 52, p 2-105); 77-mm HEAT-T, M310 Series for Recoilless Rifles (Ref 52, pp 2-13 & 2-14); 76-mm HEAT-T, Comp B, M496 for Gun Cannons (Ref 52, p 2-40); 90-mm HEAT-T, M431 for Gun Cannons (Ref 52, p 2-61); 105-mm HEAT-T, M67 for Howitzer Cannons (Ref 52, p 2-117); 105-mm HEAT-T, M324 for Recoilless Rifles (Ref 52, p 3-25); 120-mm HEAT-T, M469 (T153E15) for Gun Cannons (Ref 52, p 2-78) and 152-mm HEAT-T-

MP, XM409E3 for Gun Cannons, (where MP signifies "multipurpose") (Ref 52, p 2-85)

The same type of projectile but without tracer was used in 57-mm HEAT, M307 for Recoilless Rifles (Ref 52, p 3-8); 90-mm HEAT, M348 for Gun Cannons (Ref 52, p 2-60); 90-mm HEAT, M348 Series for Gun Cannons (Ref 52, p 2-60); 90-mm HEAT, M371 Series for Recoilless Rifles (Ref 52, pp 3-21 to 3-23); 105-mm HEAT, M67 for Howitzer Cannons (Ref 52, p 2-117); 105-mm HEAT, M341 for Recoilless Rifles (Ref 52, p 3-25); and 106-mm HEAT, M344 Series for Recoilless Rifles (Ref 52, pp 3-31 to 3-33)

HEI-T, SD (High-Explosive, Incendiary-Tracer, Shell Destroying) Projectile is described here as 40-mm Fixed Ammunition MK2 & MK11 for Automatic Guns and its complete round is shown in Fig 34 (See also Ref 40b, p 27 and Ref 52, p 2-19)

HE, RA (High-Explosive, Rocket Action) Projectile used in 105-mm Semifixed Ammunition M548 is shown here in Fig 43b, where it is briefly described (Ref 52 & Appendix, pp 2-115 & 2-116)

HEP-T (High-Explosive, Plastic-Tracer) Projectiles are used against tanks. Information about their construction is classified, but they are described in confidential Technical Manual TM 9-1300-203-1 (1961). The following calibers are listed in Refs 40b & in Ref 52: 75-mm HEP-T, T165E11 for Gun Cannons (Ref 40b, p 37); 77-mm HEP-T, M349 for Recoilless Rifles (Ref 52, p 3-14); 90-mm HEP-T, T142 Series for Gun Cannons



Fig 1-7 TYPICAL AP-T (ARMOR-PIERCING-TRACER)
PROJECTILE

(Ref 40b, p 60 & 65 and Ref 52, p 2-61); 105-mm HEP-T, M327 for Howitzer Cannons (Ref 40b, p 75 & Ref 52, p 2-118); 105-mm HEP-T, M326 and 106-mm HEP-T, M346A1 for Recoilless Rifles (Ref 52, pp 3-26 & 3-27); and 165-mm HEP, M123E1 for Gun Cannons (Ref 52, p 2-95)

Typical AP-T (Armor-Piercing-Tracer) Artillery Projectile, such as used in 120-mm AP-T Separated Projectile M358, is shown in Fig 1-7. Its solid cylindrical body (called "slug" or "shot"), made of hardened steel, has a pointed nose, a flat base and two girding metal rotating bands. A tracer is inserted in the cavity of the base. The nose of proj is covered with a metallic (such as of forged Al) windshield (also known as "ballistic cap" or "false ogive"), which makes the

proj streamlined. When the proj hits the target, the windshield collapses, and the sharp nose of the body penetrates the target by means of kinetic energy. The separated brass cartridge case contains 29-lb of triple-base propellant M17 (See Ref 44, p C34). Length of proj as fired 17.82 inches, length of cartridge case 34.69 inches, muzzle velocity 3500fps and maximum range 2529 yds (Ref 40b, pp 84 & 167; Ref 52, p 2-80)

This type of projectile has also been used in the following fixed ammunition: 40-mm AP-T, M81 Series for Gun Cannons (Ref 52, pp 2-21 to 2-23); 75-mm AP-T, M338 Series for Gun Cannons (Ref 52, pp 2-30 to 2-32); 76-mm AP-T, M339 for Gun Cannons (Ref 52, p 2-41); 90-mm AP-T, M318 Series and AP-T, M77 for Gun Cannons (Ref 52, pp 2-62 & 2-63)

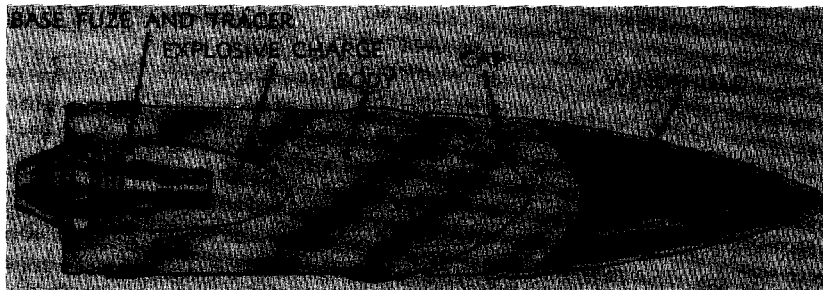

Fig 1-8 TYPICAL APC-T (ARMOR-PIERCING,
CAPPED-TRACER) PROJECTILE

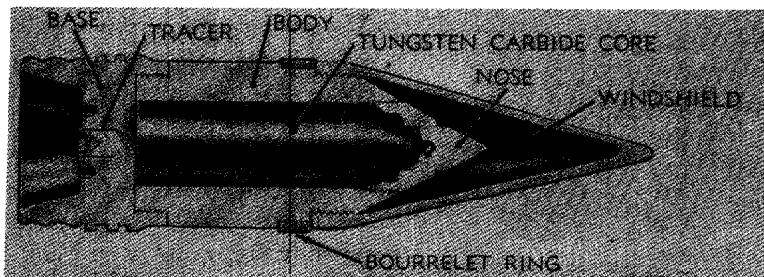

Fig 1-9 TYPICAL HVAP-T (HYPERVELOCITY, ARMOR-PIERCING-TRACER) PROJECTILE

Typical APC-T (Armor-Piercing, Capped-Tracer) Projectile, shown in Fig 1-8, consists of hardened steel monobloc body and cap of forged alloy steel. The AP cap is heat-treated to have a hard exterior and a relatively soft core. The softer core protects the hardened point from breakage by distributing the stress during impact and thus helps the penetration thru armor. Then the BD fuze functions to detonate a HE charge located in the cavity at the rear of the body (Ref 52, p 1-16 & 1-33)

It seems that this type of projectile has been used only in fixed ammunition and the following rounds are described in Ref 52: 37-mm APC-T, M59 Series for Automatic Guns (pp 2-9 to 2-11); 75-mm APC-T, M61 Series for Gun Cannons (pp 2-28 to 2-30); and 90-mm APC-T, M82 for Gun Cannons (p 2-61)

Typical HVAP-T (Hypervelocity, Armor-Piercing-Tracer) Artillery Projectile, shown in Fig 1-9, consists of a light-weight body (usually of Al) which encloses a core of extremely hard high-density material, usually of tungsten carbide. The AP cap attached to the front of the body is made of steel hardened on the exterior and softer in the interior. The function is similar to that described under APC projectile. A skirted base threaded to receive a tracer and fitted with a rotating band is attached to the rear of the Al body and a bourrelet and windshield are fitted to the forward portion. When a target (armor) is hit, the Al body with its AP cap breaks up completely, or vaporizes, leaving the tungsten carbide core to pene-

trate the armor by kinetic energy. The use of this light-weight proj enables velocities above 3500fps ("hyper velocities") to be obtained without exceeding the allowable pressure of guns designed for lower velocities and heavier projs (Ref 52, pp 1-16 & 1-33)

This type of projectile has been used in fixed ammunition only and the following rounds are described in Ref 52: 76-mm HVAP-T, M319 for Gun Cannons (p 2-42); 90-mm HVAP-T, M304 for Gun Cannons (p 2-64); and 90-mm HVAP-T, M332 Series for Gun Cannons (p 2-65)

APDS-T (Armor-Piercing Discarding Sabot) Projectile. An outside view of the 105-mm APDS-T, M392A2 Projectile is shown here in Fig 41, together with a brief description of the complete round (Ref 52, pp 2-33, 2-69 & 2-70) (Compare with 76-mm HVAP-DS-T Fixed Ammunition M331, shown in Fig 37b with a brief description)

Cutaway views of German Sabot Projectiles are shown in PATR 2510 (1958), p Ger 171 and a brief description is given on p Ger 170 (Ref 35)

Typical Canister Projectile, shown in Fig 1-10 has been used as antipersonnel ammunition in: 57-mm Ammunition T25E5 for Recoilless Rifles (Ref 52, p 3-6 and Fig 45 in this Section); 76-mm Ammunition M363 for Gun Cannons (Ref 52, p 2-38 and Fig 37a in this Section); 90-mm Ammunition M336 for Gun Cannons (Ref 52, p 2-54); 90-mm Ammunition M377 for Gun Cannons (Ref 52, p 2-55). Descriptions of canister projectiles are given together with indicated Figs and also at the beginning of this Section

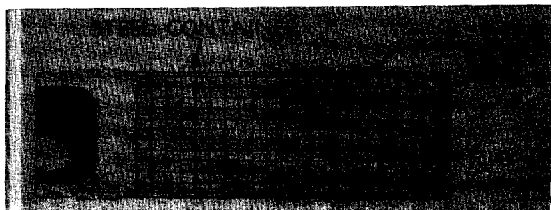

Fig 1-10 TYPICAL CANISTER PROJECTILE

A different type of canister projectile is used in 90-mm Ammunition XM590 Series for Recoilless Rifle (Ref 52, p 3-17). It is shown here in Fig 47, together with its description

APERS-T (Antipersonnel-Tracer) Projectiles. The following calibers are listed in Ref 52 and its Appendix: 90-mm APERS-T, XM580E1 for Gun Cannons (p 2-49); 105-mm APERS-T, XM546 for Howitzer Cannons (p 2-112). This projectile, together with its semifixed cartridge, is shown in Fig 43c. Its description is given accompanying the Fig; 106-mm APERS-T, XM581 for Recoilless Rifles (Ref 52, p 3-28)

155-mm Illuminating Projectile M118 Series, used in Howitzer Cannons for battlefield illumination, is shown in Fig 1-11. It

is BE (base-ejection) type and consists of a hollow steel body containing an ejection charge, a canister assembly and a parachute assembly. The nose of the projectile is threaded to receive a mechanical-time superquick fuze, and the base of the projectile is closed by a steel baseplate secured by shear and twist pins. The ejection charge is contained in a centering tube which runs from the fuze to a perforated baffleplate positioned on top of the canister assembly. The canister assembly proper consists of a first fire charge and the illuminant composition. A center wire, essentially a component of the suspension system, is attached to the canister assembly at one end, runs thru a center hole in the canisters, and is attached at the opposite end to the parachute assembly. A release sleeve is soldered to the wire near the point at which it is attached to the canister. The ejection charge, detonated by the fuze, expels the canister and parachute assemblies from the projectile by blowing out the base plate. Simultaneously, it ignites the first fire charge and the illuminant composition. The release sleeve soldered to the center wire is freed by the burning

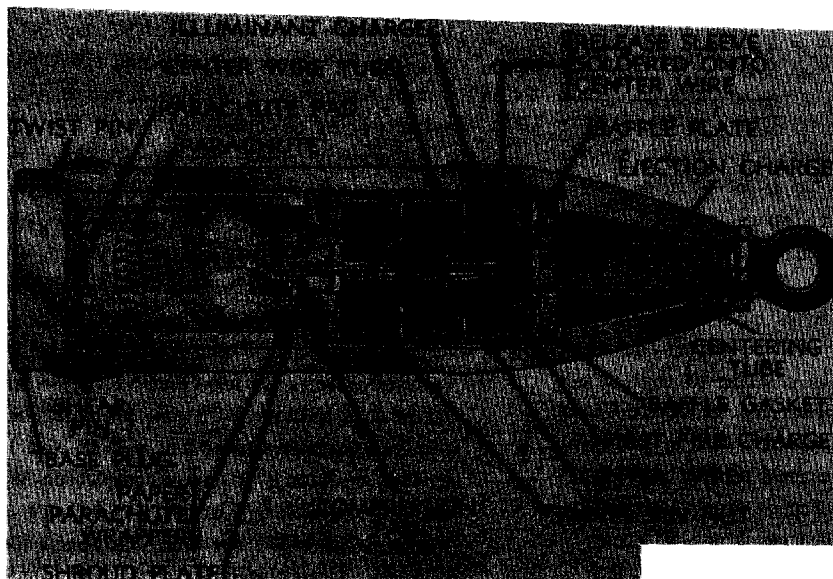

Fig 1-11 155-mm ILLUMINATING PROJECTILE
M118 SERIES FOR HOWITZER CANNONS



Fig 1-12 ILLUMINATE CANISTER FOR 155-mm
PROJECTILE M485

illuminant and fully releases the parachute assembly. Suspended by the parachute, the illuminant composition burns for approximately 60 seconds with a maximum candlepower of 400,000 candles. Length of projectile w/fuze 24.24 inches, muzzle velocity 1760fps & maximum range 12680 yds (Ref 52, pp 2-137 & 2-138)

A slightly different type of illuminate canister is used in projectile M485, which is described below and shown on Fig 1-12

155-mm Illuminating Projectile M485 is used for battlefield illumination at night and during periods of decreased visibility. The projectile, similar to M118A2, has a hollow steel body containing a primary expelling charge, a canister assembly and a drag parachute. The canister assembly (Fig 1-12) contains a secondary expelling charge, a delay holder, an illuminant composition and the main parachute. A steel base plate is press-fitted to the rear of the projectile and held in place by shear and twist pins. The exterior of the projectile is fitted with a gilding metal rotating band and a plastic obturating band

When the fuze functions, the primary ex-

PELLING charge is ignited, forcing the drag parachute and the canister assembly against the base plate, shearing the pins which hold the plate in place and expelling the parachute and canister. Concurrently, the hot gases from the expelling charge ignite the delay element. When the parachute and canister assemblies hit the airstream, the drag parachute deploys, and the anti-rotation fins unfold to show the spin of the canister. After approximately 8 seconds, the delay element burns thru and ignites the secondary expelling charge which, in turn, ignites the illuminant composition and ejects the main parachute and illuminant container from the canister assembly. The main parachute then deploys, suspending the illuminant container below it with an average descent rate of 15 feet-per-second. The burning illuminant produces approximately 1,000,000 candlepower for 120 seconds. Length of fuzed projectile is 23.79 inches; muzzle velocity and max range are the same as for M118A2 (Ref 52, pp 2-138 to 2-140)

Other Illuminating Projectiles include:
60-mm Mortar Illuminating Projectiles M83A1



Fig 1-13 120-mm WP-T (WHITE PHOSPHORUS-TRACER)
SMOKE PROJECTILE M357 (T16E4)
(BURSTER TYPE)

& M83A2 (Ref 52, p 4-14); 81-mm Mortar Illuminating Projectile M301A2 (Ref 52, p 4-34); 105-mm Howitzer Cannon Illuminating Projectile M314A2E1 (Ref 52, p 2-123); and 4.2-inch Mortar Illuminating Projectiles M335 Series (Ref 52, pp 4-53 to 4-56)

Typical Burster-Type Smoke Artillery Projectile, such as 120-mm WP-T (White Phosphorus-Tracer) Smoke Projectile M357 (T16E4) (Burster Type), shown in Fig 1-13, belongs to the type of chemical projectiles. It consists of a hollow, forged steel body filled with 7.2 lb of WP and fitted with PD fuze. There is a boss on the base of proj contg a tracer. Total length of proj is 24.02 inches. Two gilding metal rotating bands are assembled to the body just forward of the base. One end of a T20 burster casing is press-fitted in the proj nose, while the other end is seated in a well in the base of the proj cavity. The burster is filled with 0.36 lb of Tetrytol. The separated brass cartridge case contains 28.75 lb of proplnt M17 in a silk bag which is held in place by distance wadding. The primer M67 is installed in the base of the cartridge case. When fired, the flame of propelling gases ignites the tracer, which burns for 3 seconds with red light. On impact the PD fuze functions, initiating the burster chge. The resulting explosion shatters the projectile body and disperses WP. Contact with the air ignites spontaneously WP, producing dense white smoke and flaming particles. Muzzle velocity 2500fps and max range 19910

yds (Ref 40b, p 83; Ref 52, pp 2-81 to 2-83)

Similar types of WP smoke projectiles, (some of them with tracers, others without), have also been used in the following rounds of ammunition: 57-mm Recoilless Rifle Round M308 Series (Ref 52, pp 3-8 & 3-9); 60-mm Mortar Round M302 Series (Ref 52, pp 4-8 to 4-10); 75-mm Gun Cannon Round M64 (Ref 52, p 2-32); 75-mm Pack Howitzer Round M64 (Ref 52, p 2-106); 77-mm Recoilless Rifle M311 Series (Ref 52, p 3-15); 76-mm Gun Cannon Round M361 Series (Ref 52, p 2-44); 81-mm Mortar Rounds M57 Series (Ref 52, pp 4-29 to 4-31); 81-mm Mortar Round M370 (T30E9) (Ref 52, p 4-31); 81-mm Mortar Round M375 (Ref 52, p 4-32); 90-mm Gun Cannon Rounds, M313 Series (Ref 52, p 2-66 & 2-67); 105-mm Gun Cannon Round M416 (Ref 52, p 2-71); 105-mm Howitzer Cannon Round M60 (Ref 52, p 2-119); 105-mm Recoilless Rifle Round M325 (Ref 52, p 3-26); 4.2-inch Mortar Round M328 Series (Ref 52, pp 4-47 to 4-49); 105-mm Howitzer Cannon Rounds M105 & M110 (Ref 52, p 2-134 & 2-135)

There are also smoke projectiles which contain PWP (plastic white phosphorus), as, for example the 4.2-inch Mortar Projectile M2 Series, described in Ref 52, pp 4-46 & 4-47)

Other types of smoke fillers include HC and various colored smokes. Some smoke projectiles are BE (Base Ejection) type, as, for example, the projectiles described as the next item

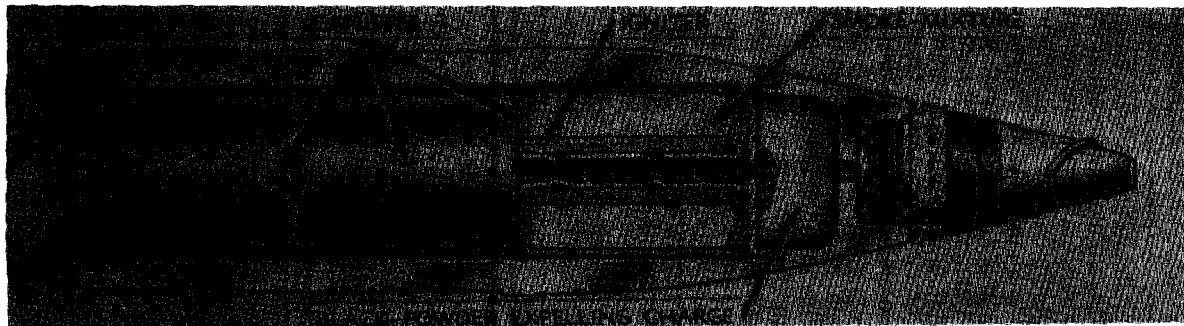

Fig 1-14 TYPICAL BE (BASE-EJECTION)
SMOKE PROJECTILE

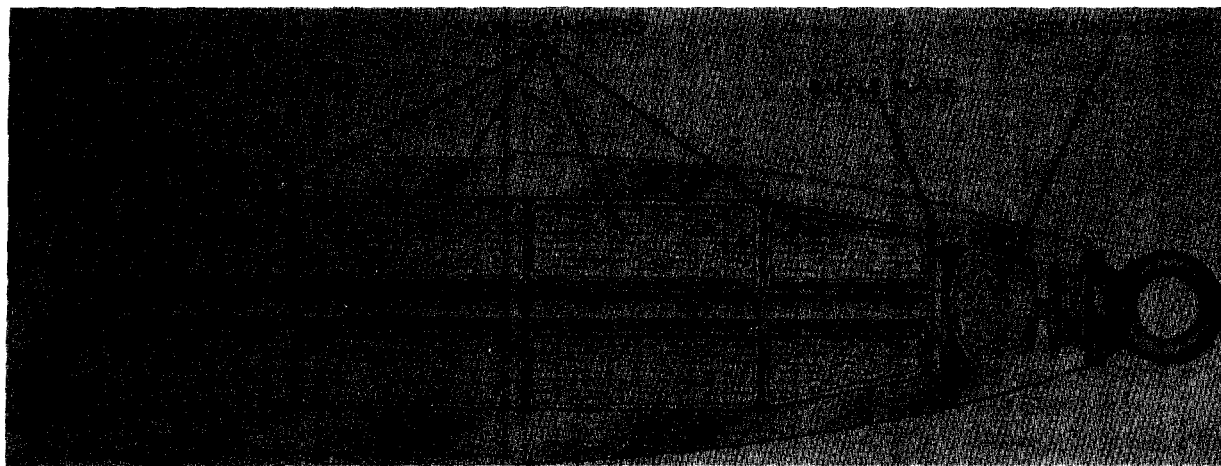

Fig 1-15 155-mm BE (BASE-EJECTION) SMOKE
PROJECTILE M116

Typical BE (Base-Ejection) Smoke Artillery Projectile, belongs to chemical projectiles. Fig 1-14 shown is taken from Ref 52, p 1-16, where no description is given

A slightly different Fig 2-92 is given in Ref 52, p 2-136 for 155-mm BE (Base-Ejection) Smoke Projectile, M116 and this is shown here as Fig 1-15. The BE smoke proj is used for screening, spotting and signalling purposes and can also contain chemical fillers, such as HC (hexachloroethane), or a green, red, violet or yellow chemical smoke mixtures. An expelling charge of 0.28-lb of BkPdr contained in a cloth bag (or 0.34 lb in a polyethylene cup for projectile M116B1) is positioned forward of a baffle plate in the nose of proj.

The remainder of the proj interior holds four canisters of smoke mixture arranged one behind the other. The forward canister is conical to conform to the taper of the forward part of proj. A flash tube is formed by the hole in the baffle plate and the center tube of each canister. The base of the proj is closed by a threaded base plug. When the PD fuze functions, it ignites the expelling chge of BkPdr, sending the flame thru the flash tube and this ignites the smoke mixt in canisters. Simultaneously, the force of expelling chge blows out the base plug and ejects the canisters. An effective smoke cloud is emitted within 30 secs of ignition; the average canister burning time is 90 secs. Length of projectile (w/eyebolt plug) 27.56 inches, muzzle

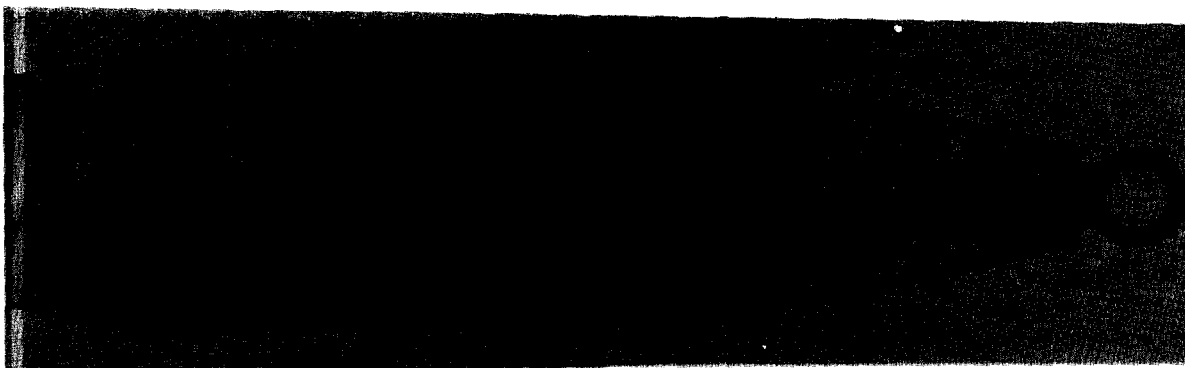

Fig 1-16 155-mm CS TACTICAL PROJECTILE XM631

velocity 1220fps with M3 proplnt and 1840fps with M4 or M4A1 proplnt; corresponding max ranges are 10780 & 16335 yds (Ref 52 & Appendix, pp 2-135 to 2-137)

This BE type of smoke projectile has also been used in: 105-mm Howitzer Cannon as 105-mm Smoke BE Projectile M116 (Ref 52 & Appendix, p 2-135)

155-mm CS Tactical, Base-Ejection Type Projectile XM631 (Fig 1-16), is one of the gas projectiles. It is intended to harass personnel by irritating fumes produced by CS riot control agent: CS, which is a code name for o-chlorobenzal malononitrile (Ref 57, p 161), causes extreme burning of the eyes, coughing, difficulty in breathing and chest tightness. This projectile is similar in external configuration to illuminating projectile M118A2, shown in Fig 1-11. The hollow steel projectile is assembled with an MTSQ fuze and is fitted with a gilding metal rotating band, a plastic obturating band, a pinned base plug, five CS-pyrotechnic-filled canisters and an expelling charge. The expelling charge (3.36 ounces of BkPdr contained in a plastic container) is assembled to the rear of the fuze and is separated from the CS canister by a baffle plate. Each CS canister contains approximately two pounds of CS-pyrotechnic mix and .81 ounces of starter mix. Each canister has a perforated flashtube in its center. The base plug is assembled to the projectile by means of three shear pins. When target is reached,

the expelling charge, ignited on fuze functioning, ignites, in turn, the canisters.

The pressure produced by the expelling gases shears the pins in the base plug and ejects the burning canisters. The average canister burning time is 90 secs. Length of fuze proj 27.56 inches, muzzle velocity and max range are the same as for illuminating projs (Ref 52 and Appendix, pp 2-134 & 2-135)

A similar proj 4.2-inch Tactical CS, XM630 for Mortar Ammunition is described in Ref 52, p 4-52

155-mm VX Persistent Gas Projectile M121A1, used in Howitzer Cannons, is shown in Fig 1-17. It belongs to the burster type. Its body consists of a deep-cavity steel shell contg a filler of ca 6.0 lb of VX gas (formula is classified) and a burster charge loaded with 2.45 lb of Comp B in burster casing. A burster support holds the burster in the proper position. The nose of the proj is fitted with an adapter threaded to receive either a VT or PD fuze. (During shipment, the adapter is fitted with a lifting plug). A supplementary chge used with PD fuzes, is positioned in the fuze cavity and held in place by spacers. A gilding metal rotating band encircles the proj near the base.

When the fuze functions, it detonates the burster, rupturing the projectile body and releasing the filler. VX gas remains effective for more than 10 minutes from the time of release. Length of proj (w/eyebolt lifting plug) 26.73 inches; muzzle velocities when fired from howitzer cannons, 1230fps with M3 proplnt

Fig 1-17 155-mm VX PERSISTENT GAS PROJECTILE M121A1

chge and 1840fps with M4 or M4A1; corresponding maximum ranges are 10820 yds & 15958 yds (Ref 52 & Appendix, pp 2-132 & 2-133)

Similar in construction to the above gas projectiles are the following listed in Ref 52: 105-mm Gas GB Non-Persistent Projectile M360 for Howitzer Cannon (p 2-120); 105-mm Gas H & HD Persistent Projectile M60 Projectile for Howitzer Cannon (p 2-120); 4.2-inch Gas Non-Persistent (CNB, CNS, CK or CG) M2 Series Projectile for Mortar (pp 4-51 & 4-52); 4.2-inch Gas Persistent (H, HD or HT) M2 Series Projectile for Mortars (pp 4-51 & 4-52); 155-mm Gas GB Non-Persistent M121 Series Projectile for Howitzer Cannons (p 2-133); 155-mm Gas GB Non-Persistent M122 Projectile for Gun Cannons (p 2-93); 155-mm Gas HD Persistent, M104 Projectile for Gun Cannons (p 2-92); 155-mm Gas H or HD Persistent Projectile M110 for Howitzer Cannon (p 2-131); 8-inch Gas GB, Non-Persistent Projectile M426 for Howitzers (p2-146); and 8-inch Gas VX Persistent Projectile M426 for Howitzers (p2-146)

Leaflet Projectiles are similar in construction to BE Gas Projectiles (such as shown on Fig 1-14 or 1-15, except that their payloads consist of propaganda leaflets

Only one of such projectiles is listed in Ref 40b, p 75 and Ref 52, p 2-122. It is 105-mm BE Leaflet Projectile M84 for Howitzer Cannon

Target Practice (TP) and Target Practice-Tracer (TP-T) Projectiles. Their definition is given at the beginning of this section. The following TP, TP-T and Training projectiles are described in Ref 52: 37-mm TP-T, M55A1 (p 2-11); 40-mm TP-T, M91 (p 2-23); 57-mm TP, M306 Series (p 3-9); 60-mm Training, M69 (p 4-14); 75-mm Training M28 (p 2-108); 75-mm TP, M309 Series (p 3-16); 81-mm TP, M43A1 (pp 4-36 to 4-38); 81-mm Training, M68 (p 4-38); 90-mm TP, M71 (p 2-67); 90-mm TP-T, M353 Series (p 2-67); 105-mm Practice M371 (p 3-23); 105-mm TP-T, M393A1 (p 2-76); 90-mm TP-T, M461E1, M467 & M49 (p 2-72); 105-mm TP and TP-T, M67 (p 2-118); 120-mm TP-T, M359E2 (p 2-82); and 152-mm TP-T, M411E3 (p 2-86)

Projectile Simulators. Their definition is given at the beginning of this section, but their description is given in "Military Pyrotechnics", TM 9-1370-200 (1966) (Ref 51c, pp 5-13 to 5-18)

Dummy Projectiles. Their definition is given at the beginning of this section. The following caliber dummy and empty projs are described in Ref 52: 37-mm M21 (p 2-13); 40-mm M17 Series & M25 (p 2-24); 75-mm M7 & M16 (pp 2-34 & 2-35); 75-mm T146B1 (p 2-37); 75-mm Empty M334 (T50E2) (p 2-37); 75-mm Dummy M2A2 and M19 Series (p 2-109); 90-mm M12 Series (p 2-68); 105-mm M14 (p 2-125); 106-mm M368 (p 3-33); 120-mm M15



Fig 1-18 75-mm BLANK CARTRIDGE W/SINGLE
PELLET (BAG) CHARGE

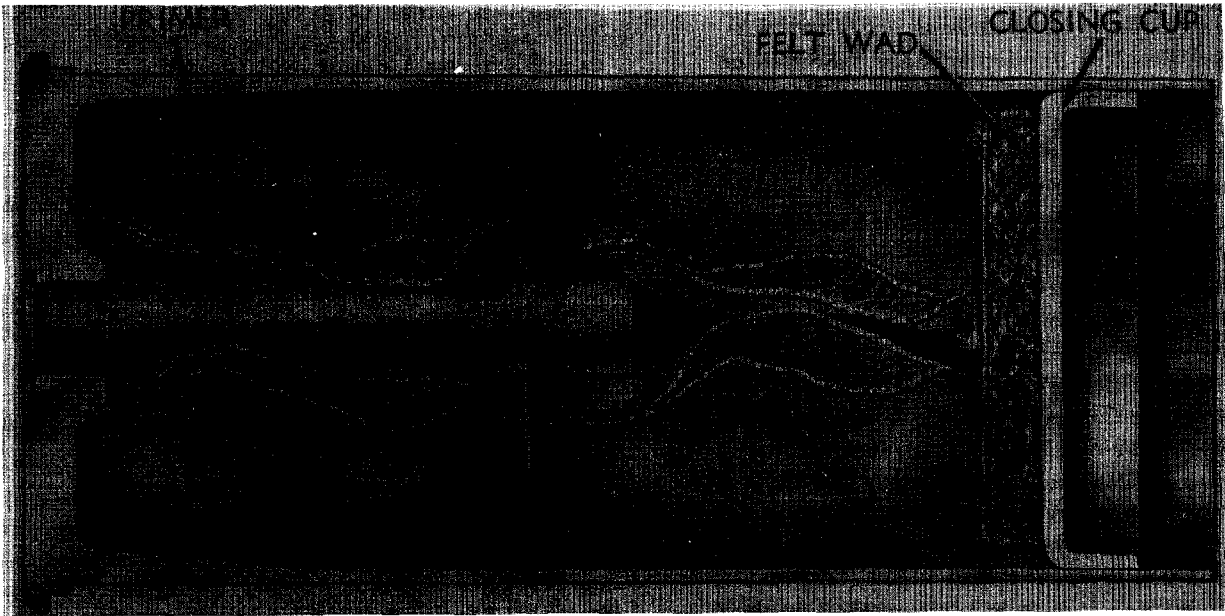

Fig 1-19 75-mm BLANK CARTRIDGE W/DOUBLE
PELLET (BAG) CHARGE

(p 2-75); 155-mm M7 Series (p 2-94); 155-mm M7 and MK1 (p 2-141); 175-mm M458 (p 2-101); 8-inch M14 (p 2-146); and 280-mm T299E2 (p 2-103)

Blank Ammunition. Its definition is given at the beginning of this section. There is no projectile in such ammunition, but just a cartridge, provided with a primer, igniter, charge of explosive (such as BkPdr), a felt wad and a closing cup. Loud noise is produced on firing these cartridges which are used for saluting and training purposes.

Many blank cartridges are described in Refs 40b and 52. We are giving here only two typical examples (See Figs 1-18 & 1-19) reproduced from Ref 52, p 2-33. Same Figs are given in Ref 40b, p 34

Section 4, Part B

b) Projectiles Used in Recoilless Rifles

The following complete rounds of ammunition for recoilless rifles are described in Ref 52:

- 57-mm: Canister T25E5; HE, M306; HE, M306A1; HEAT, M307A1; Smoke, WP, M308; and Target Practice, M306 & M306A1 (pp 3-3 to 3-9)
- 75-mm: HE, M309 & M309A1; HEAT-T, M310 & M310A1; HEP-T, M349; Smoke, WP, M311 & M311A1; and Target Practice M309 & M309A1 (pp 3-12 to 3-16)
- 90-mm: Canister, A/P, XM590 & XM590E1; HE, XM591; HEAT, M371A1; and Practice, M371 (pp 3-16 to 3-23)
- 105-mm: HE, M323 (T42); HEAT, M341; HEAT-T, M324; HEP-T, M326; and Smoke, MP, M325 (pp 3-24 to 3-26)
- 106-mm: APERS-T, XM581; Dummy, M368; HEAT, M344 & M344A1; and HEP-T, M346A1 (pp 3-27 to 3-33)

Figs 45, 46, 47, 48 & 49 in Section 3, Part D, give cutaway views of typical 57, 75, 90, 105 & 106-mm recoilless rifle ammunition

Fuzes used in recoilless rifle projectiles are listed in Section 5, Part C, item f

Section 4, Part B

c) Projectiles Used in Mortars

The following complete rounds of ammunition for mortars are described in Ref 52:

- 60-mm: HE, M49A2; HE, M49A2E1; HE, M49A2E2; Illuminating, M83A1, M83A2 & M83A3; Smoke, WP, M302 & M302E1; and Training, M69 (pp 4-3 to 4-14). The same rounds are described in Ref 41, pp 7 to 15
- 81-mm: HE, M43A1 & M43A1B1; HE, M56 and M56A1; HE, M362 & M362A1; HE, M374; Illuminating, M301A1 & M301A2; Smoke, WP, M57 & M57A1; Smoke, WP, M370 (T90E9); Smoke, WP, M375; TP, M43A1; and Training M68 (pp 4-18 to 4-38). The same rounds are described in Ref 41, pp 15 to 28
- 4.2-inch: Nonpersistent Gas (CNB, CNS, CK, CG), M2 & M2A1; Persistent Gas (H, HD, HT), M2 & M2A1; HE, M3A1 & M3A1 alt; HE, M329, M329A1 & M329B1; Illuminating, M335, M335A1 & M335A2; Smoke, PWP or WP, M2 & M2A1; Smoke, WP, M328 & M328A1; and Tactical-CS, XM630 (pp 4-43 to 4-56). The same rounds are described in Ref 41, pp 28 to 41

Figs 59, 61, 63 & 64 in Section 3, Part D give cutaway views of typical mortar ammunition

Fuzes used in mortar projectiles are listed in Section 5, Part C, item g

Section 4, Part B

d) Grenades, Hand and Rifle

A brief definition of "grenade" is given in Glossary, Section 2, Part A

A detailed description of grenades is given in TM 9-1900 (1956), pp 102-114 (listed here as Ref 32) and in TM 9-1330-200 (1966) (listed here as Ref 51b)

Grenades are classified accdg to method of projection as "hand" or "rifle"; accdg to use as "service", "practice", or "training"; and accdg to filler as "explosive", "chemical", "illuminating", "inert", or with a "spotting charge" filler

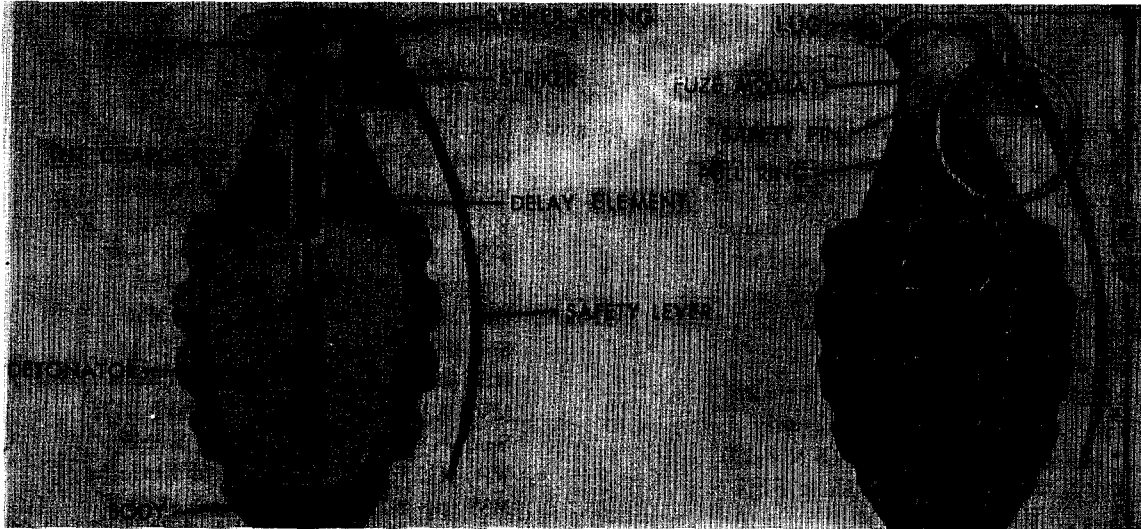

Fig 1-20a FRAGMENTATION HAND GRENADE Mk2
W/FUZE M204A2

There are now four types of *hand grenades* used by US Armed Forces: fragmentation, illuminating, chemical and practice & training. The fifth type, an "offensive hand grenade" is now obsolete, but description of its MK3A2 model is given in Ref 51b, p 2-29. It consists of a pressed-fiber, cylindrical body filled with 8 oz of flaked TNT and fitted with a long fuze well. Its fuze is shipped separately. These grenades were used principally for blast effect. The same action can be achieved by means of a 1/4 or 1/2 pound demolition charge fitted with a fuze previously used in offensive hand grenades (Ref 51b, p 1-9)

There are now three general types of rifle grenades used in US: high-explosive antitank, practice and chemical (Ref 51b, p 1-10)

Hand Grenades include the following:

Fragmentation Hand Grenade, Mk2 (See Fig 1-20a), known as "pineapple", is described in Ref 32, p 104 and Ref 51b, p 22. It has a deeply serrated cast iron body filled with 2 oz of flaked TNT and fitted with one of the fuzes M6A4C, M204A1 or M204A2 (These fuzes are not described in Ref 51b)

After the safety pin is withdrawn and the grenade is thrown, the striker is released and driven by its spring hits the primer. The

primer emits a small intense spit of flame thus igniting the delay element, which, after burning for 4-5 secs, sets off the detonator which initiates the TNT chge. The resulting shattering effect ruptures the body projecting the fragments, some of which may be dangerous as far as 185 meters

This grenade is now replaced with grenade M26-series (See next item)



Fig 1-20b FRAGMENTATION HAND GRENADE M26
W/FUZE M215

Fragmentation Hand Grenade, M26, (See Fig 1-20b) consists of a smooth, thin sheet steel shell, lined inside with a notched fragmentation wire coil and filled with 5.5 oz of Comp B. Three models of these grenades are available. Grenade M26A2 shown in Fig 1-20c uses M215 or M217 fuzes. Grenades of the M26 series are more effective than Mk2, although fragments are smaller. Functioning of M26 is similar to that of Mk2 (Ref 51b, p 2-4)

power supply which causes the fuze to arm within 1 to 2 seconds. After arming, the grenade will function on impact when solid target is hit from a height of not less than 16 feet. If no detonation occurs on impact, the grenade detonates after 3 to 7 secs delay and if no detonation takes place within 30 secs after launching, the grenade becomes a dud (Ref 51b, pp 2-6 to 2-9)

Illuminating Hand Grenade, Mk1 (See Fig 1-20d) consists of a thin steel body,

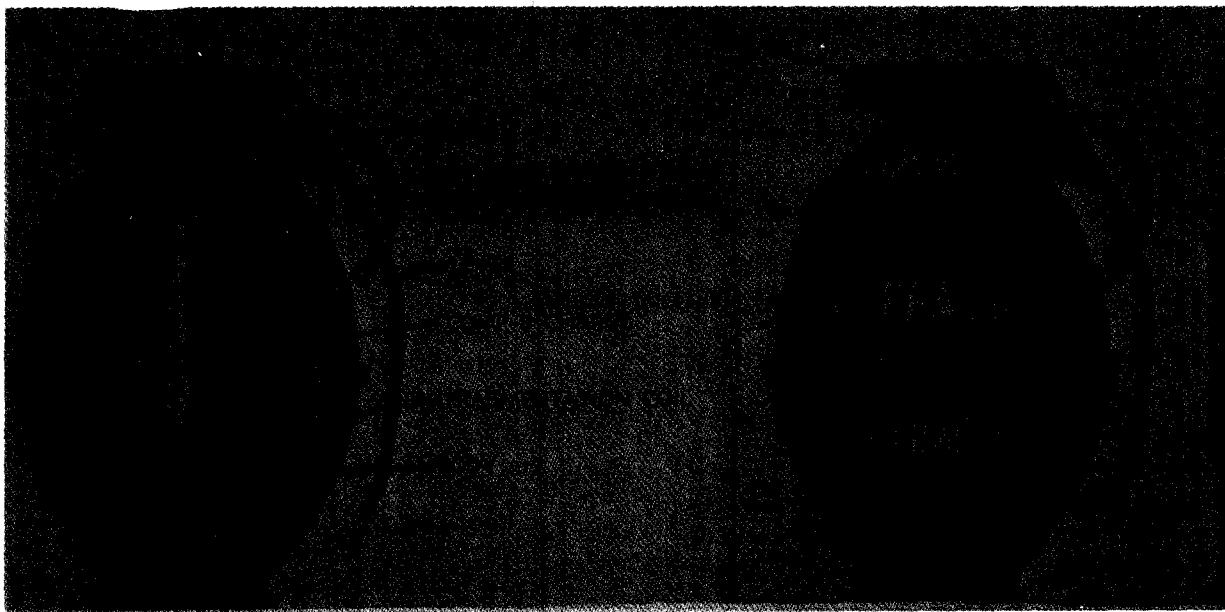

Fig 1-20c FRAGMENTATION HAND GRENADE M26A2
W/FUZE M217

Fragmentation Hand Grenade M26A2, using fuze M217, was developed as a replacement of grenades Mk2; M26, and M26A1 (using fuzes M204A1 & M204A2) and of grenade M26A2, previously using fuze M215. Both of these fuzes are shown in Figs 1-100 & 1-101 in Section 5, Part D

Grenade M26A2 with fuze M217, which is shown in Fig 1-20c, has the same type of body as grenade M26. Its diam is 2.25 inches and length with fuze 3.81 in

Upon releasing the lever, the striker assembly throws off the lever (thru the action of the spring), and strikes the percussion primer. The primer initiates the thermal

filled with 3.5 oz of a pyrotechnic illuminating composition and fitted with a special igniter-type fuze. When the safety pin is withdrawn and the grenade thrown, the striker is released to be driven by its spring towards the percussion primer. This produces an intense flame which ignites the quickmatch. After burning for 7 secs, the igniter charge is ignited and then first fire compn and illuminating charge. The gas pressure produced on burning causes upper part of body (including fuze) to be separated, from the lower part, leaving the illuminating compn to burn with candlepower of 55000 for ca 25 seconds (Ref 51b, pp 2-10 & 2-11). Fuze for this

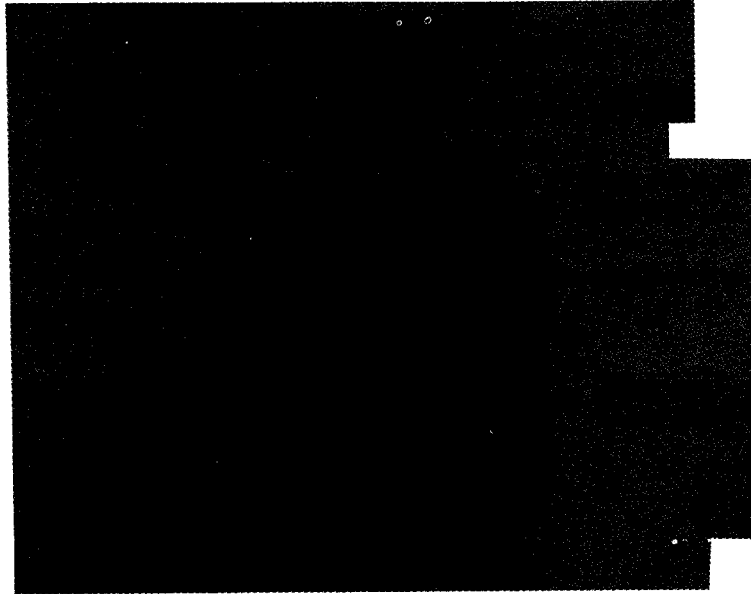

Fig 1-20d ILLUMINATING HAND GRENADE Mk1
W/DELAY IGNITION FUZE

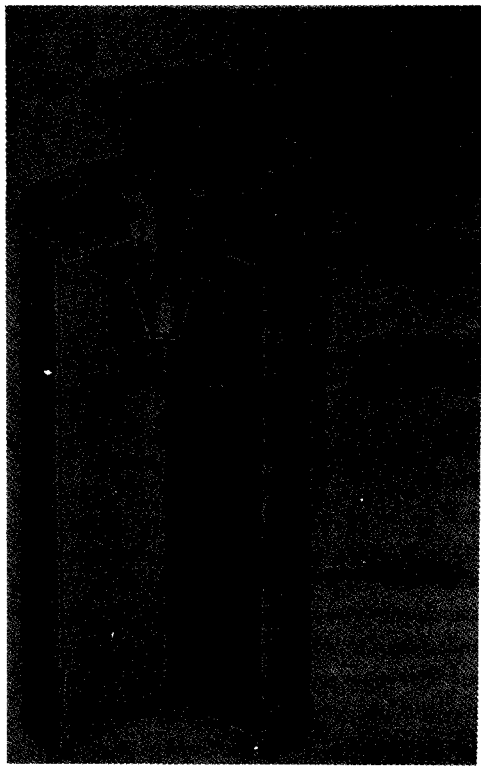

Fig 1-20e SMOKE HAND GRENADE, HC, AN-M8
W/FUZE M201A1

grenade is not described in Ref 51b

Chemical Hand Grenades are cylindrical in shape, except *Riot Grenade CN1, ABC-M25A1* which is round in shape (See Ref 51b, p 2-23, Fig 2-20)

As a typical example we are describing *Smoke Hand Grenade, HC, AN-M8, w/Fuze M201A1* (See Fig 1-20e). It consists of a metal cylinder (2.5 inches in diameter and 4.5 inches in height) filled with 19 oz of Type C HC smoke mixture, and fitted with a fuze M201A1 described in Section 5, Part D, Fig 1-102. Four emission holes in the top of the grenade are covered with an adhesive tape to protect the filler from moisture. A plastic cylinder in the top of the filler contains starter mixture which is centered under the fuze. For its functioning, the safety pin is withdrawn and the grenade is thrown. Then the striker, driven by its spring, forces the safety lever out of its path and throws it free of the grenade. This releases the striker to hit the percussion primer. The flash emitted by primer ignites the delay element of the fuze. After burning for 1 to 2 secs, the ignition & starter mixture and then the filler are ignited. The re-

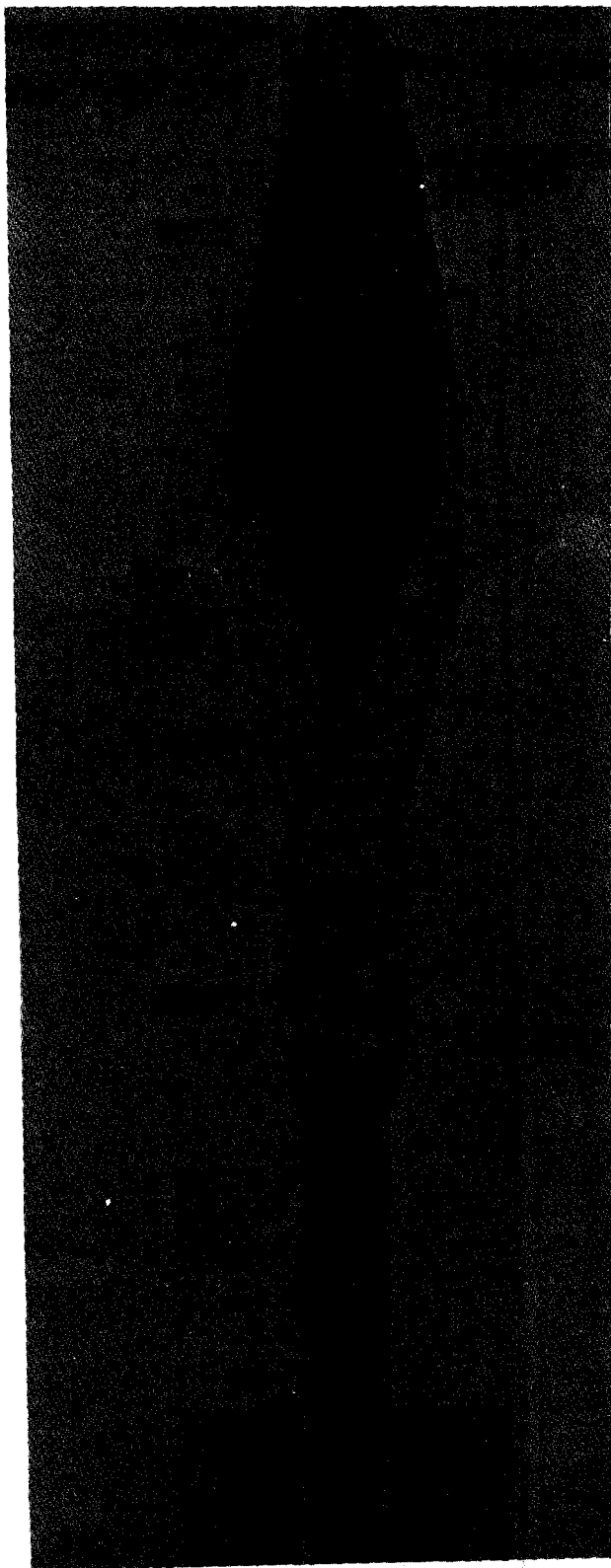

Fig 1-20-f ANTITANK RIFLE GRENADE HEAT,
M31 W/FUZE M211

sulting pressure blows the tape covering the holes on top of the cylinder, thus allowing a dense smoke to escape for 105 to 150 seconds (Ref 51b, p 2-16)

Other *Smoke Hand Grenades* include: WP, M15 (Ref 51b, p 2-20, Fig 2-18); Colored Smoke M18 (pp 2-21 & 2-22, Fig 2-19); WP, M15 (p 2-21); and WP, M34 (pp 2-24 & 2-25, Fig 2-21)

Incendiary Hand Grenade, TH3, AN-M14 is described in Ref 51b, p 2-17 and shown in Fig 2-15

Riot Hand Grenades include M6, M7A1, M7A2, M7A3, ABC-M25A1 and ABC-M25A2. They are described in Ref 51b, pp 2-12 to 2-15 & 2-22 to 2-25

Practice and Training Hand Grenades include: M21, M30 (T39), Mk1A1 and Riot Simulant T1, M25A2 (Ref 51b, pp 2-25 to 2-28)

Rifle Grenades include the following:

Antitank Rifle Grenade HEAT, M31, with M211 Fuze shown in Fig 1-20f, consists of three basic parts: the body, the fuze, and the stabilizer. Its cylindrical steel body, 2.61 inches in diameter, has conical ogive and conical rear section. The ogive contains a piezoelectric (LUCKY) assembly in the nose. A "lead" wire (in conduit) connects this assembly to M211 fuze, in the base of the body. (This fuze is not described in Ref 51b) Grenade body contains 9.92 oz of Comp B molded against a steel, shaped-charge, liner. A booster is housed in the base of the body. Total length of grenade is 16.96 inches

When the grenade is fired from a rifle equipped with a grenade launcher, the setback leaf assembly of the grenade releases the small rotor which turns 90°, opening the "shorting switch" and closing the "firing switch". This switch is contained within the rotor, which is locked until firing into the short circuit position by a setback leaf assembly

When grenade strikes the target, a piezoelectric crystal in the nose is stressed, thereby generating an electrical impulse. This impulse is then conducted to the detonator of fuze M211 which initiates the booster and shaped charge of Comp B. As result of the jet created on detonation, the shaped charge can

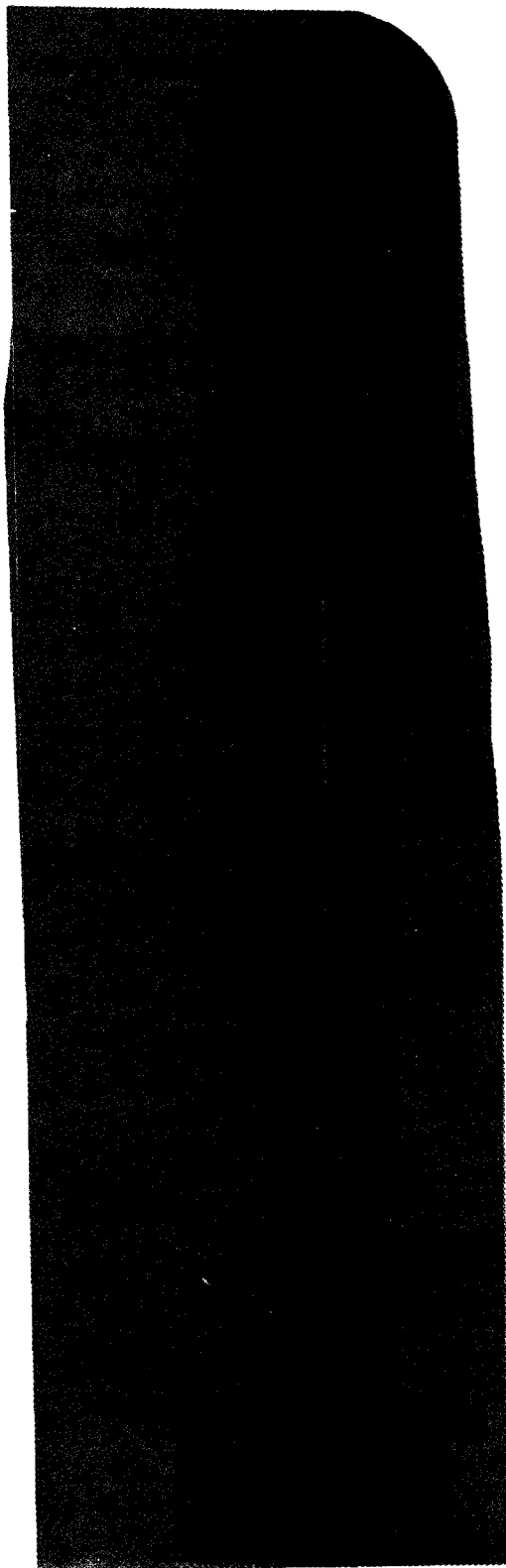

Fig 1-20g SMOKE RIFLE GRENADE, WP, M19A1
W/FUZE MID

penetrate an armor plate of 10 inches or more or 20 inches of reinforced concrete. Max range ca 185 meters at 45° elevation

Smoke Rifle Grenade, WP, M19A1 with MID Fuze, shown in Fig 1-20g, consists of three basic parts: the body, the fuze, and the stabilizer, made of steel. The cylindrical body, 2-inches in diameter, is made of sheet steel and is fitted with a rounded ogive. It is filled with 8.5 oz of white phosphorus and is completely sealed to prevent the entrance of air. The fuze is MID (mechanical impact detonating) type. Total length of grenade is 11.31 inches

After being fired from a rifle equipped with a grenade launcher, and the grenade's ogive strikes the ground or other resistant object, the following action takes place: Inertia of the firing pin overcomes spring tension and firing pin strikes the primer. The small intense spit of flame emitted by primer is transmitted to detonator. Expln of detonator ruptures the body, scattering its fragments and particles of WP over an area of ca 20 meters. On coming into contact with air, WP ignites and produces an intense cloud of white smoke. This grenade may be used for incendiary purposes, against flammable materials (Ref 51b, pp 3-5 to 3-7)

Rifle Grenades: Green, Red, or Yellow Smoke, M22-Series, are similar in appearance and operation to rifle grenade M19A1, except that their fillers consist of 0.4 pounds of baking soda, K perchlorate, sugar and a dye to color the smoke. They are provided with MII (mechanical impact igniter) fuze (Ref 51b, p 3-7 to 3-9)

Streamer Rifle Grenades: Green, Red, or Yellow Smoke, M23-Series are similar in appearance to M22 series but differ in operation. They are designed to be projected from rifles fitted with a grenade launcher, using a grenade cartridge. When this cartridge is fired it propels the grenade and ignites the igniter of "igniting fuze", which, in turn, ignites 0.4 lb of the same smoke charge as in M22 series. As the grenade travels along its trajectory, air entering thru an opening at the nose, forces the smoke out of the holes in the base of the body, producing a streamer of colored smoke along the entire trajectory of the grenade. These grenades are used only for signalling purposes (Ref 51b, pp 3-9 to 3-10)

Practice Antitank Rifle Grenade M29 (T42) is used for training. It has no filler nor fuze. Its body is of cast iron and its stabilizer tube-fin assembly is of steel. Maximum range is ca 150 meters (Ref 51b, p 3-11 & 3-12)

Rifle Grenade Fuzes, such as MID (mechanical impact detonating) fuze for use in Smoke, WP, Grenade, M19A1; MII (mechanical impact igniter) fuze for use in Smoke Grenade M22; and Ign (igniting) fuze for use in Smoke Streamer Grenade M23 are not described in Ref 51b

Rifle Grenade Cartridges, shown in Fig 1-20h, were designed for projecting rifle grenades from rifles equipped with grenade launchers. When such a cartridge is fired, it generates a large volume of high-pressure gas which propels the grenade from the launcher. Only two grenade cartridges are authorized for use by the US Army: one is M3 for projecting from .30 cal Rifle M1 and another M64



Fig 1-20h RIFLE GRENADE CARTRIDGES, M3 & M64

for projecting from 7.62-mm Rifle M14 (NATO). Cartridge M3, 2.49 inches long, is loaded with 51 grains of IMR 4895 propellant; total wt of cartridge is 200 grains. Cartridge M64, 2.0 inches long, is loaded with 41 grains of IMR 4895 propellant; total wt of cartridge is 185 grains (Ref 51b, p 3-18)

Grenade Projection Adapters.

These devices are designed to adapt hand grenades for launching from rifles fitted with grenade launchers. This permits one to convert a hand grenade into a rifle grenade, thus extending its range. One of the types of adapters, M1A2, is designed for round or lemon-shaped

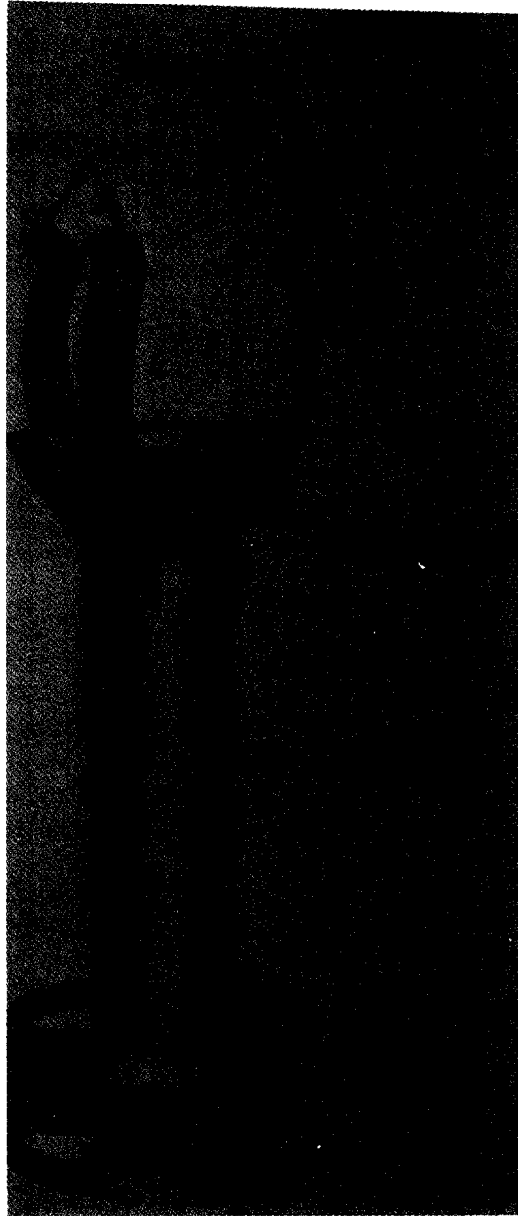

Fig 1-20i GRENADE PROJECTION ADAPTER, M1A2

grenades, such as shown in Figs 1-20a to 1-20d. The adapter consists (See Fig 1-20i) of a stabilizer tube with a fin assembly on one end and gripping claws on the other end. The claws, made of spring steel, grip the grenade and hold it in place on the adapter

Another type adapter, M2A1, designed for use with cylindrical grenades, such as chemical or riot grenades is shown in Fig 1-20j. An

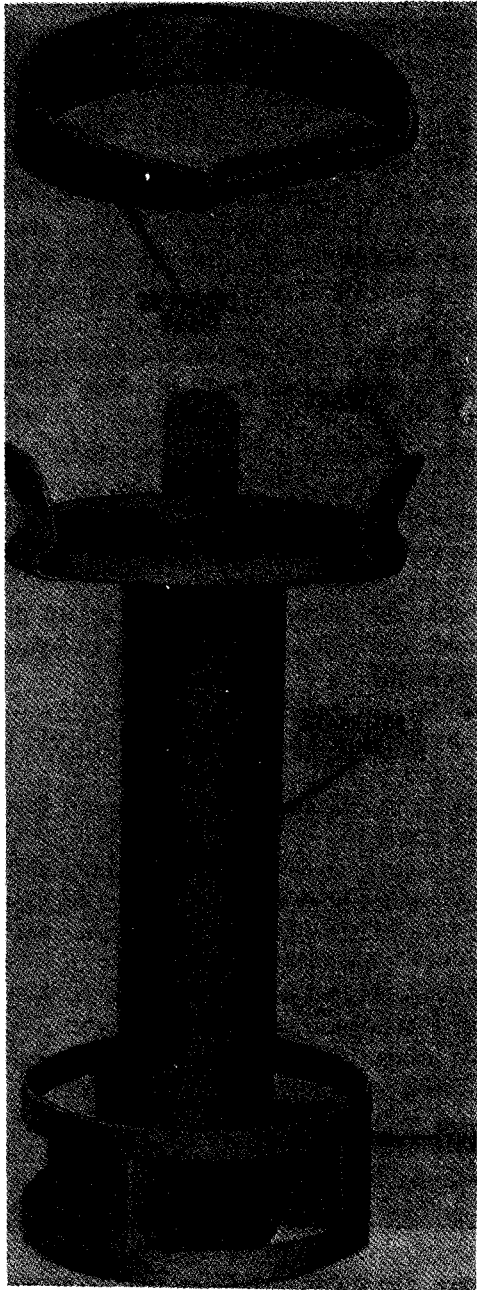

Fig 1-20j; GRENADE PROJECTION ADAPTER, M2A1

example of cylindrical grenade fitting this adapter, is shown in Fig 1-20e (Ref 51b, pp 3-12 to 3-17)

Section 4, Part B

e) Guided Missiles and Rockets

As this is a comparatively new subject and many US items are classified, we are not describing them now, but expect to describe guided missiles and rockets in one of the future volumes

US rocket ammunition, described in Ref 36a, is more than 10 years old

Due to the fact that some US guided missiles and rockets developed after WWII, are modifications and improvements of missiles and rockets developed in Germany before and during WWII, there follows a list of such missiles, as described in PATR 2510 (1958) (Ref 35):

Faustpatrone (Rocket Grenade) (p Ger 46)
Guided Missiles: Schwetterling, Wasserfall, Rheintochter, Enzian, Feuerlilie, Rubrstahl, Beethoven, Fritz X, Taifun & Henschel (pp Ger 81 to Ger 85)
Guided Missile Natter (p Ger 116)
Panzerfaust (Rocket Grenade) (pp Ger 126 & 127)
Püppchen (Wheeled Bazooka) (p Ger 152)
Rheinbote (Guided Missile) (p Ger 157)
Rockets (Raketen): 73-mm, 86-mm, 88-mm, 150-mm, 152-mm, 210-mm, 280-mm, 300-mm, and 380-mm (pp Ger 160 to Ger 163 with 16 figs)
Rocket Launchers: Panzerschreck, Wurfrahmen, Wurfgerät, Nebelwerfer & Panzerwerfer (pp Ger 164 to Ger 165 with 8 figs)
V-1 oder Vergeltungswaffe Eins (V-1 or Revenge Weapon One) (p Ger 213)
V-2 oder Vergeltungswaffe Zwei (V-2 or Revenge Weapon Two) (pp Ger 213 & Ger 214)
V-3 oder Vergeltungswaffe Drei (V-3 or Revenge Weapon Three) is a Supergun, known as *Hochdruckpumpe* (Ref 35, p Ger 90)

Section 4, Part C

Definition of Terms Used for Initiating Components of Artillery Projectiles

a) Definition of Fuze Detonator

According to definition given by Ohart (Ref 17, p 55), such a detonator is "an explosive component for initiation of detonation in an explosive train or transmitting a primer im-

pulse to the next element of the train, usually a booster". This, rather short, definition can be supplemented with the following which may be considered as a combination of definitions given in Ref 23, p 4-1; Ref 40a, p 60 & Ref 45a). A *detonator* is an *explosive train component* which can be activated to perform three distinct functions by either one, two or three different explosive charges. These functions are: 1) Initiation of deflagration 2) Transformation of deflagration to detonation and 3) Transfer of the detonating impulse to the next element of the train

The definition of fuze detonator given in Ref 52, p 5-2 is "A detonator is used in the explosive train to create a detonating wave, then transmit it to the next component"

Initiation of a detonator can be achieved either by a non-explosive impulse (such as impact) or by a primer, located separately. When initiated by a nonexplosive impulse, the primer is part of detonator and this combination may be called *primer-detonator*

The *deflagration* [See Vol 3, p D38-R (Ref 48)] may be initiated in a *priming mixture* (known also as the *upper* or *top charge* located in the sensitive end of the detonator. The transition from *deflagration* to detonation (See Vol 3, p D39-L & Vol 4 in Section DETONATION, etc) is usually effected by an intermediate charge of LA (lead azide), although MF (mercuric fulminate) and DAZDNPh (diazodinitrophenol), abbr also as DDNP, and DADNPh, have also been used for this purpose. The transfer of detonation to the next component of the "explosive train" (See below), usually a booster, may be done by LA, but in case of more powerful detonators a high explosive base charge such as Tetryl, PETN, or RDX performs this function. Detonators are usually classified according to the method of initiation as flash, stab and electric detonators. In older Technical Manuals, percussion detonators are listed

The term "detonator" is sometimes applied to an explosive device placed in certain equipment and set to destroy the equipment under certain conditions. It is preferred, however, to call it *Destructor, Explosive*. Several types of US destructors are described in Vol 3, pp D92-R to D96 (Ref 48)

It should be noted that a detonator, by itself, cannot initiate a large quantity of an insensitive HE (TNT, PA or Comp B), which is used as a filler for projectiles, bombs, mines, etc. Such HE's must not be too sensitive in order not to create hazard in handling and transportation. They could be, however, initiated by a very powerful detonator, such as contg a large quantity of a sensitive explosive such as LA, LSt or MF. This would also be undesirable because handling and transportation of large quantities of such expls is very hazardous

It has been found by ammunition designers that for an efficient and safe method of initiation of large expl chges, it is necessary to start with a small quantity of very sensitive, but not very powerful material known as *priming mixture*, which is loaded in a metallic cup to form a *primer*. The next element must contain a larger amount of somewhat less sensitive but more powerful material, which is loaded in a metallic cap to form a *detonator*. The next element must contain an even larger quantity of even less sensitive but more powerful material and this comprises a device called a *booster*. The last element must contain a large quantity of insensitive but very powerful material and this comprises the *main charge* of a projectile, bomb, rocket, or guided missile. This charge is also called *bursting charge, filling charge* or *filler*

Combination of these elements forms an *explosive train*, also called *high-explosive train* or *bursting charge explosive train* to distinguish it from a *propelling charge train* or low explosive train which consists of a primer, igniter and propelling charge. Such a train is described in Section 3 and is also shown here in Fig 20

If a HE train is used in artillery fuzes it might be called *artillery ammunition train*

Section 4, Part C

b) High-Explosive Train or Bursting Charge Explosive Train

Some bursting explosive trains have the primer and detonator combined into one component. Such a device is known as *primer-detonator*. If a definite time delay in the

train is desired, a BkPdr pellet or gasless *delay element* is inserted between the primer and detonator. An additional element called a *relay* may be required to provide continuity of the explosive train by picking up the weak flash from the delay element and then, in turn, properly initiating the detonator. The necessity of the relay depends upon the actual train design and the relative positions of the elements (For description of delays and relays, see Section 4, Part F)

Some explosive trains contain a *lead*, which consists of a small diameter column of explosive (such as Tetryl or RDX). It is usually employed to transmit the detonation impulse from a detonator to a booster (Ref 17, pp 19-20, Ref 23, pp 6-1 to 6-4, & Ref 40a, pp 60 & 94). More detailed description of lead is given in Section 4 of this work

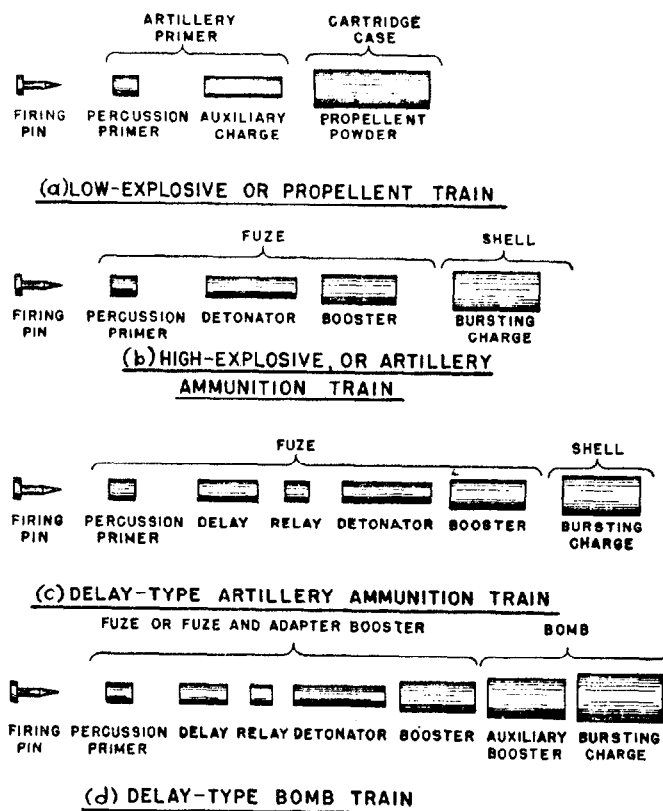

Fig 1-21a DIAGRAM OF ELEMENTS OF EXPLOSIVE TRAINS

The term "lead" used for designation of the device used in explosive train should not be confused with "leads", "leading wires", or "lead-wires", which are electric wires connected to bridges of electric detonators or of blasting caps. In order to avoid confusion, we usually call these wires "leading wires" [See Vol 2, p B187-R (Ref 44)]. They are also called "leg wires" (See Ref 44, p B188, Figs)

Ohart (Ref 17, p 20) gives a diagram of elements of explosive trains, both of low- and high-explosive, which are reproduced here as Fig 1-21a

It shows in (a) the usual low-explosive train, consisting of the artillery percussion primer with its small sensitive primer element, and a larger igniting charge, followed by the large propellant charge. High-explosive or artillery ammunition train, non-delay is shown in (b), while the delay-relay train is in (c). A bomb delay train with delay, relay and two boosters (because of large quantity of bursting charge) is shown in (d)

Both low- and high-explosive trains are components of a complete round of ammunition (See Ref 43, p A385-L). The high-explosive train is always located in a *fuze* (See below), which can be attached either to the point or to the base of projectile. The low explosive train is located in case of fixed- or semifixed-ammunition inside the cartridge (See Ref 44, p C73-L), while for separate-loading ammunition, the propellant primer is inserted by hand into the breech-block of the weapon after loading, thru the breech, of projectile and the cartridge bags (See Ref 44, p C77-L)

In Fig 1-21b is shown a complete explosive train (comprising both low- and high-explosive trains) in fixed round of artillery ammunition

In order to understand clearer the function of elements in HE trains of fuzes, a description and sectional views of US Naval Base Fuze Mk21 are given. This information is derived from the comprehensive "Ordnance Explosive Train Designers' Handbook", NOLR 1111 (Ref 23, pp 1-4 & 1-5) (See Figs 1-22 & 1-23)

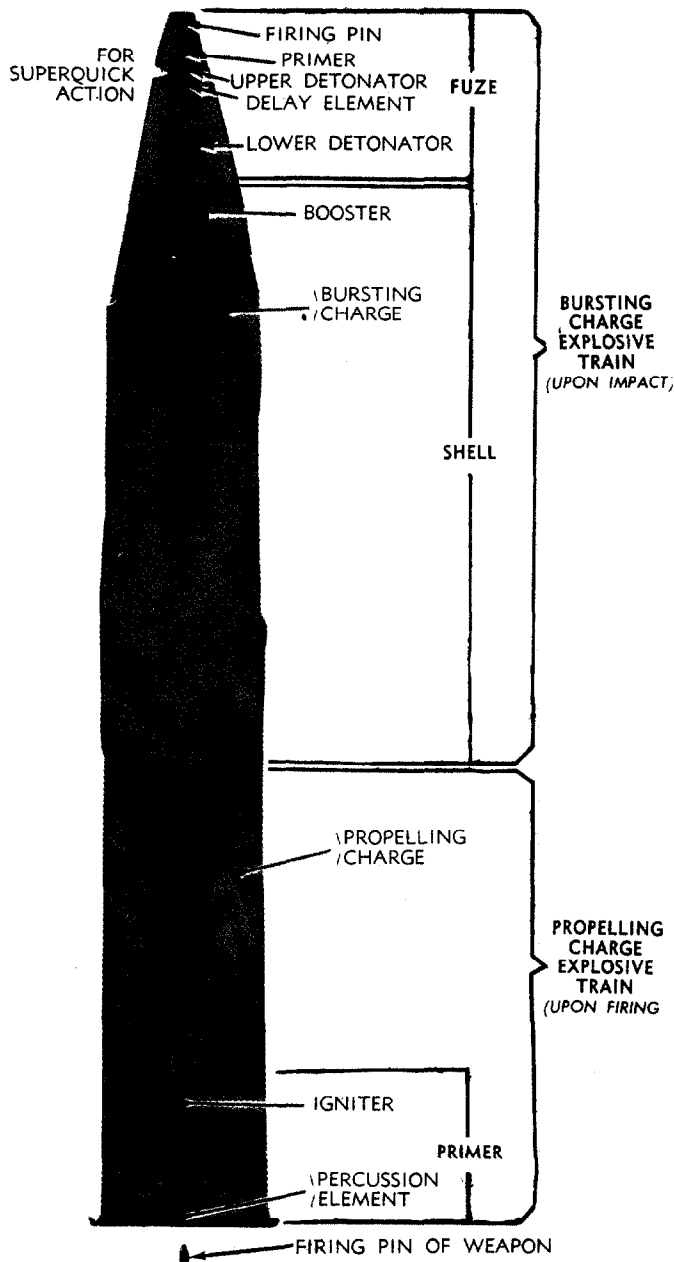

Fig 1-21b EXPLOSIVE TRAINS IN FIXED ROUND OF ARTILLERY AMMUNITION

The function of this fuze is to initiate, following a delay of 0.035 second after impact with steel armor plate, a high-order expln in the filler of projectiles from 6 to 16 inches in diam. The central axial assembly of the fuze, which is mounted on ball races, moves

forward on plate impact against the *antireep spring*, causing the *stab primer* to impinge on the *firing pin*. The primer, designed for maximum sensitivity to initiation on impact with this type of firing pin, is loaded with a *priming composition* consisting of a mixt of Basic LSt, Sb trisulfide, Ba nitrate, Tetracene & LA; the expln of this mixt forces the *delay element firing pin* into the *delay element primer*. This primer, which is percussion type, is loaded with a mixt similar to that used in the stab primer except that it does not contain LA. It differs from stab primer in two respects: firstly its housing is stronger and is not punctured during actuation, a characteristic which makes possible maintenance of a gas seal on the next element, the *delay pellet*; and secondly, it is inherently less sensitive to impact than the stab primer

The hot gases from the percussion primer permeate thru the *baffle* and initiate the BkPdr *delay pellet*, which burns under the reproducible pressure conditions which are obtained within the delay element housing, with a delay time of 0.035 sec. When the BkPdr element has burned thru, a spit of flame impinges on a *detonator* loaded with LA; a true detonation develops and progresses successively thru the Tetryl-loaded *lead-out*, the Tetryl-loaded *booster lead-in*, the Tetryl-loaded *booster* and Explosive D (Ammonium Picrate)-loaded *main (or bursting) charge* of the projectile. Some fuzes contain also a *relay* (See Glossary, Section 2, Part A)

NOTE: 1) As one proceeds down any HE train, the size of the expl elements from the primer to the main chge increases while their sensitivity to initiation decreases
2) As implied in the word "train", each element has two ends and concomitant with this fact has two characteristics, an input characteristic and an output one. For example the percussion primer is tested by *drop weight apparatus* (such as represented in Fig 9-1, p 9-5 of Ref 23), to determine its input end characteristics, while its output end characteristic is given by the number of calories of heat developed on the firing and which appears in its output flame. The LA detonator is characterized on its input end by flame sen-

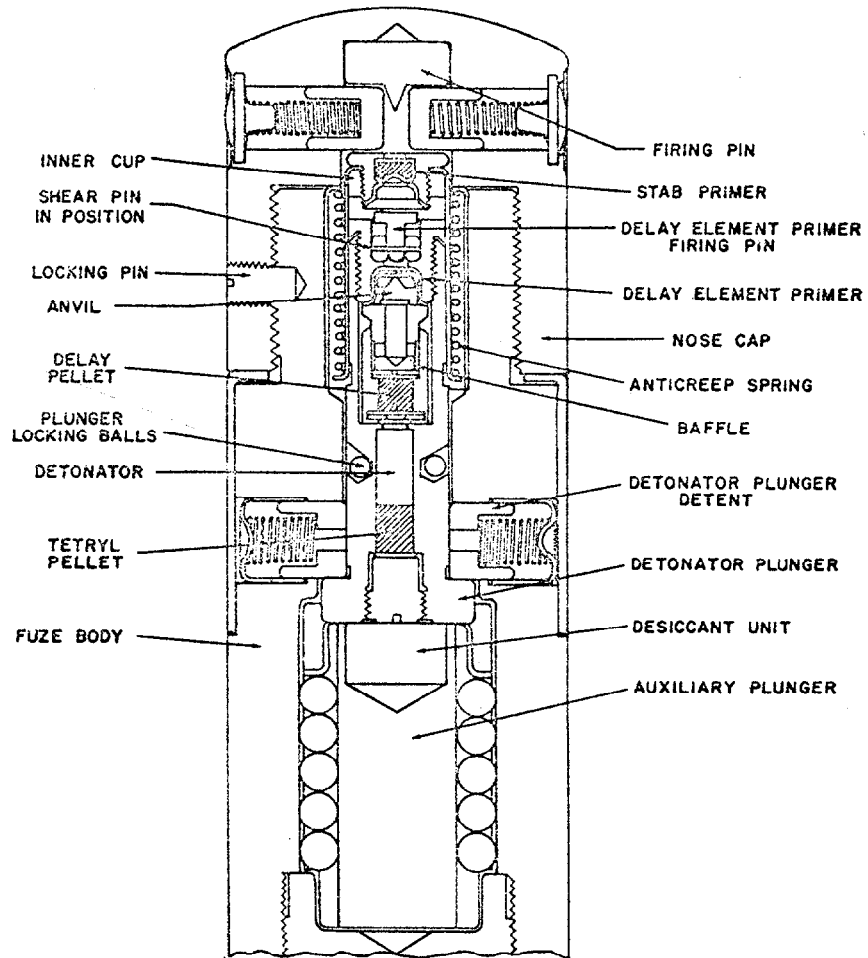

Fig 1-22 BASE FUZE Mk21 (ASSEMBLED POSITION)

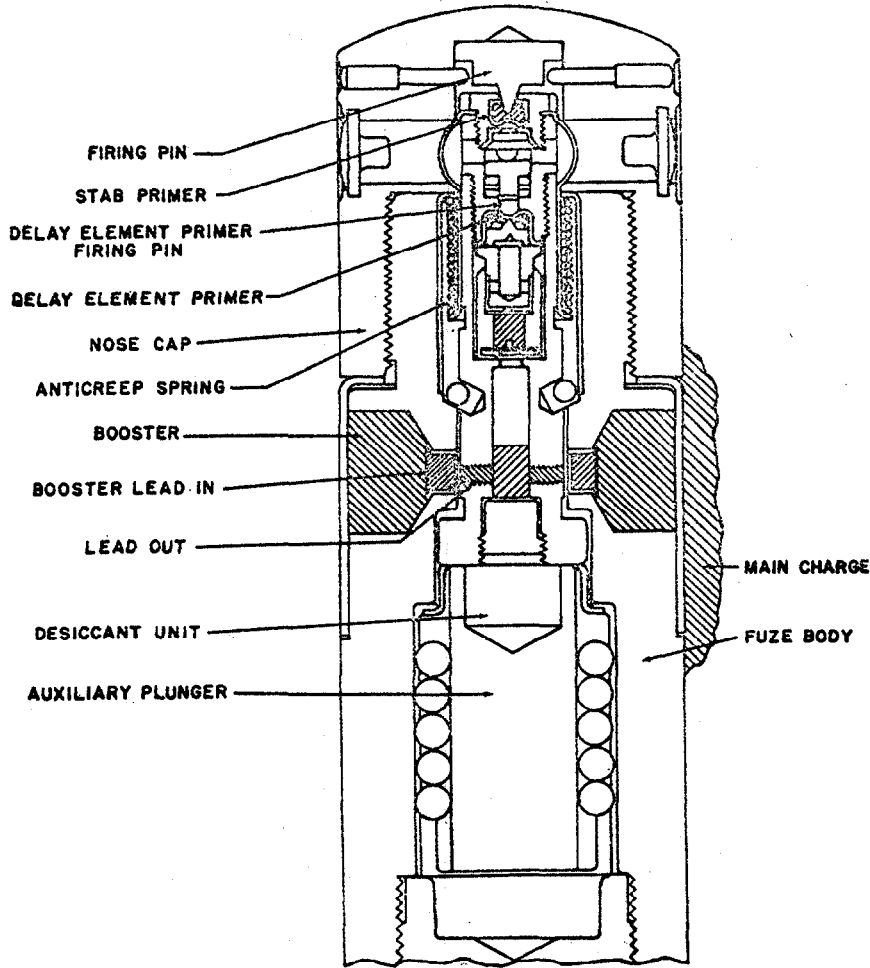

Fig 1-23 BASE FUZE Mk21 (FIRING POSITION)

sitivity (as measured, for example, in oxy-hydrogen bomb apparatus described in Ref 23, p 9-16) and its output end characteristic by the peak pressure developed at the detonation front where it contacts the succeeding element in the train. Pressure measurement can be done by the Hopkinson Bar Test, as described in Ref 23, pp 9-33 to 9-39 and in Vol 1 of Encycl (Ref 43), p XVI

Section 4, Part D

Description of Instantaneous Fuze Detonators

Fuze detonators may be subdivided into *instantaneous* and *delay*. (Delay types are described in Section 4, Part F). Both types may also be classified according to the method of initiation into flash, stab and electric

fuze detonators (Ref 23, p 4-1 & Ref 52, p 5-2)

Following are examples of instantaneous fuze detonators:

a) Instantaneous Flash Fuze Detonators

This type of detonator is designed to deliver a detonating impulse when acted upon by a heat impulse or a detonating impulse generated by a previous element. In the latter case it serves for boosting the detonating impulse. Heat impulses may result from the flash of a delay element in delay type fuzes or the flash from a primer in instantaneous type fuzes. When initiation results from the functioning of a previous detonator, the flash type detonator usually serves in the capacity of a *relay* where the gap over which the detonation must be transmitted is too

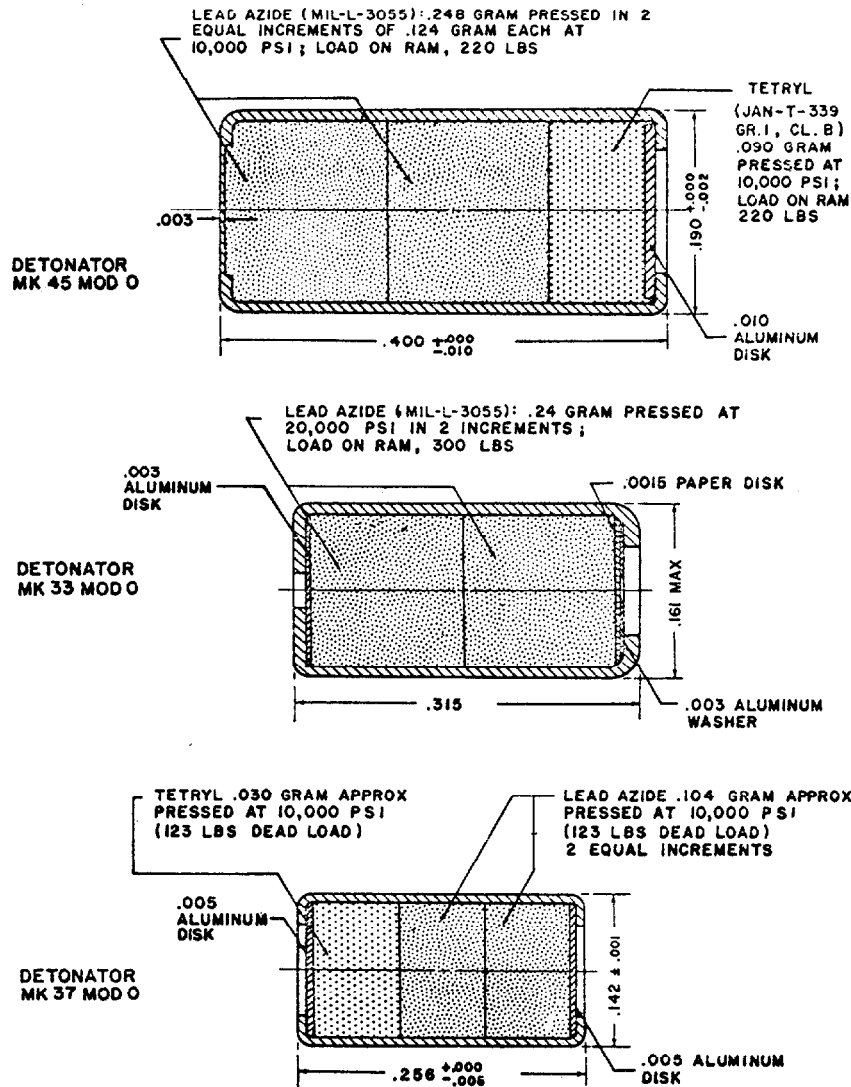

Fig 1-24 EXAMPLES OF FLASH TYPE FUZE DETONATORS

great for the primary detonator to be effective. Lack of stab or percussion sensitivity makes flash detonators useful only where the initiation impulse is supplied by a previous explosive element

The construction of flash type detonators is similar to other detonators. Each flash type detonator consists of a metal capsule containing a charge of expls. The capsule, which is usually of Al (on account of presence of LA as an expl ingredient in US Army and Navy flash detonators) may be closed with paper or thin Al disk, as indicated in Fig

4-1 given in Ref 23, p 4-4 and reproduced here as Fig 1-24. In another variation, the closure of the initiating end of the detonator is the solid end of detonator cup *coined* to a reduced suitable thickness, while the opposite end is closed with a thick Al disk. This type of cup is used in Mk45 Mod O Detonator (See Fig). It is a *compound detonator* containing both LA (as a primary charge) and Tetryl (as a base charge). This detonator is initiated in a fuze by the Primer Mk113 (not described in NOLR 1111), and in turn initiates a Tetryl lead

The Detonator Mk33 Mod O (See Fig) contains only one ingredient (LA), although it is in two, differently compressed increments. This detonator may be called *plain (or simple) detonator* to distinguish it from "compound detonators", such as Mk45 Mod O, described above or Mk37 Mod O described below. The initiating end of Mk33 Mod O is covered with a paper disk and an Al washer, while the other end is covered with an Al disk retained by a partial crimp. This detonator is initiated by the spit from a BkPdr delay element in a delay fuze, such as Mk19 Base Fuze, or by the spit of a percussion primer in an instantaneous fuze such as the Mk28 Base Fuze. Detonator Mk33 initiates a Tetryl lead in both delay and instantaneous fuzes

The Detonator Mk37 Mod O is a "compound detonator" contg two increments of LA and one of Tetryl. It is used in auxiliary detonating Fuzes Mk44 & 46 and is initiated by the detonation of a LA detonator in the nose fuze. Detonator Mk37 initiates a Tetryl lead (Ref 23, pp 4-1 to 4-5)

The compn of some foreign flash detonators used during WWII was, accdg to analyses made at PicArns (Refs 8 & 12a), different from those used in USA. Following is a copy of Table 4-1 given in Ref 23, p 4-3

Accdg to Ref 52, p 5-2, Tetryl is not the only explosive used as a base charge in US Army detonators, because PETN and RDX are also used in current flash-, stab- and electric-detonators

Table 4-1. Explosive Charges Used in Foreign Flash Detonators

| Detonator upper (flash sensitive) charge composition | Detonator base charge | Ammunition | Origin |
|--|---------------------------|-------------------------------|----------|
| Black Powder | Mercury Fulminate | 90-mm HE Shell | French |
| Loose Mercury Fulminate | Pressed Mercury Fulminate | 81-mm HE High Capacity Mortar | Italian |
| Mercury Fulminate | Tetryl | Grenade | Japanese |
| Lead Azide | Tetryl | 25-mm HE Shell | Do |
| Lead Azide | PETN | 20-mm HE Shell | German |
| Lead Azide (75%) PETN (25%) | PETN | Rifle Grenade Discharger | Japanese |
| Lead Azide (77±8%) Lead Styphnate (23±8%) | PETN | 80-mm Mortar | German |
| Lead Azide (58±2%) Lead Styphnate (42±2%) | PETN | 75-mm Howitzer | Do |
| Lead Azide (80%) Lead Styphnate (20%) | PETN (94%) Wax (6%) | 75-mm AP Capped Pak 40 | German |
| Lead Azide (60%) Lead Styphnate (30%) PETN (10%) | PETN | 30-mm Bounding Type | Do |
| Lead Azide (51.7%) Lead Styphnate (48.3%) | RDX | 47-mm HE Grenade | Italian |
| Lead Azide (76%) Lead Styphnate (24%) | RDX (96.5%) Wax (3.5%) | 38-mm Capped | German |
| Separate Charges of Lead Azide, Lead Styphnate | PETN | 20-mm AP | Italian |
| Separate Charges of Lead Azide, Lead Styphnate | Tetryl | 76-mm HE | Russian |

In Table 5-1, p 5-4 of Ref 52 are listed: Navy Mk37 Flash Detonator, as used in Fuze, Proximity M513 Series and the following Army flash detonators: M17, M30, M30A1, M49 and M60. No cuts of these detonators are given in Ref 52, but the cut of M17 is given in Ref 20a, Fig 143, p 244 and Ref 41, Fig 21, p 43. As the cut of M17 is given in the above Refs on the same pages together with stab fuze detonators, they are shown here the same way (See under Stab Fuze Detonator)

Section 4, Part D

b) Instantaneous Stab Fuze Detonators

This type of detonator usually serves as an initiating element of a fuze. When its sensitive end is struck with a sharp firing pin, the pin penetrates thru the thin wall (usually a disc) and initiates the primary charge. This starts the action of other elements of explosive train which consists of a Tetryl "lead", a relay detonator, and a booster charge. The stab detonator consists of a cup, which is made of Al or Al base alloys if LA is one of the expl ingredients, whereas Cu or Cu base alloys are used for detonators contg MF. The cup might have any one of several designs of its sensitive end closures, such as: two disk-closed ends; one disk-closed end & one coined end; one coined end & one open end; and one disk-closed end & one open end

The meaning of "coined" end is explained under Flash Fuze Detonator

The length of US Military stab detonators varies from 0.250 to 0.750 inch and the external diam from 0.110 to 0.300 inch; the wall thickness of cups from 0.005 to 0.025 inch, while the thickness of sensitive end varies from 0.001 to 0.005 inch

Priming charges are the same as listed under Stab Fuze Primer, while Tetryl, PETN & RDX are used as the base charge

Two types of US Navy stab fuze detonators represented in Fig 4-2, p 4-10 of Ref 23 are shown on Fig 1-25. Detonator Mk26 Mod O used in Fuzes Mk135 & Mk142 is initiated by a firing pin driven by spring action. The detonator cup is of Al and is closed at both ends with Al disks. It functions as the initi-

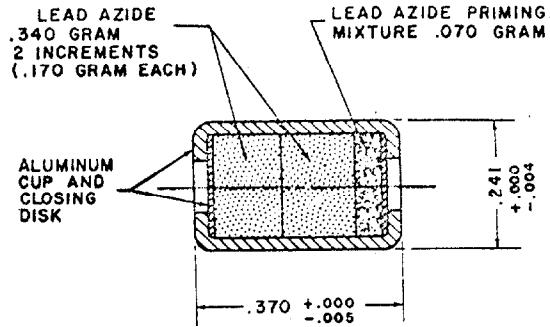

LEAD AZIDE PRIMING MIXTURE

| | | | |
|--------------------|--------|-----------|---|
| LEAD AZIDE | 28.3 % | ± 2 | % |
| POTASSIUM CHLORATE | 33.4 % | ± 2 | % |
| ANTIMONY SULFIDE | 33.3 % | ± 2 | % |
| CARBORUNDUM | 5.0 % | ± 0.5 | % |

DETONATOR MK 26 MOD O

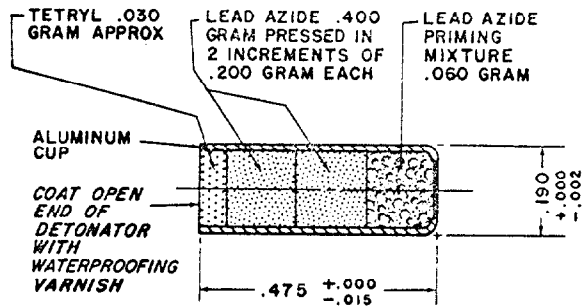

DETONATOR MK 28 MOD O

Fig 1-25 TWO GENERAL TYPES OF STAB FUZE DETONATORS

ator of a Tetryl *lead-in*. Detonator Mk28 Mod O consists of an Al cup open at one end, while its solid end is coined thin at the center. After loading Tetryl at the open end, a coat of waterproof cement is applied on the surface of Tetryl (Ref 23, pp 4-8 to 4-10)

In Ref 52, Table 5-1, p 5-4, shown here as Fig 1-26, are listed the following US Army stab fuze detonators: M18, M19A2, M22, M23, M24, M29, M42, M44, M47, M50 & M63. As no cuts of any of these detonators are given in Ref 52, the cuts given in Ref 41, p 43, Fig 21 for stab detonators M18, M24 & M44 and for flash detonator M17 are used. In these cuts, the lower(base) charge can be Tetryl, RDX or PETN, the intermediate charge is LA and the upper (top) charge is a priming composition

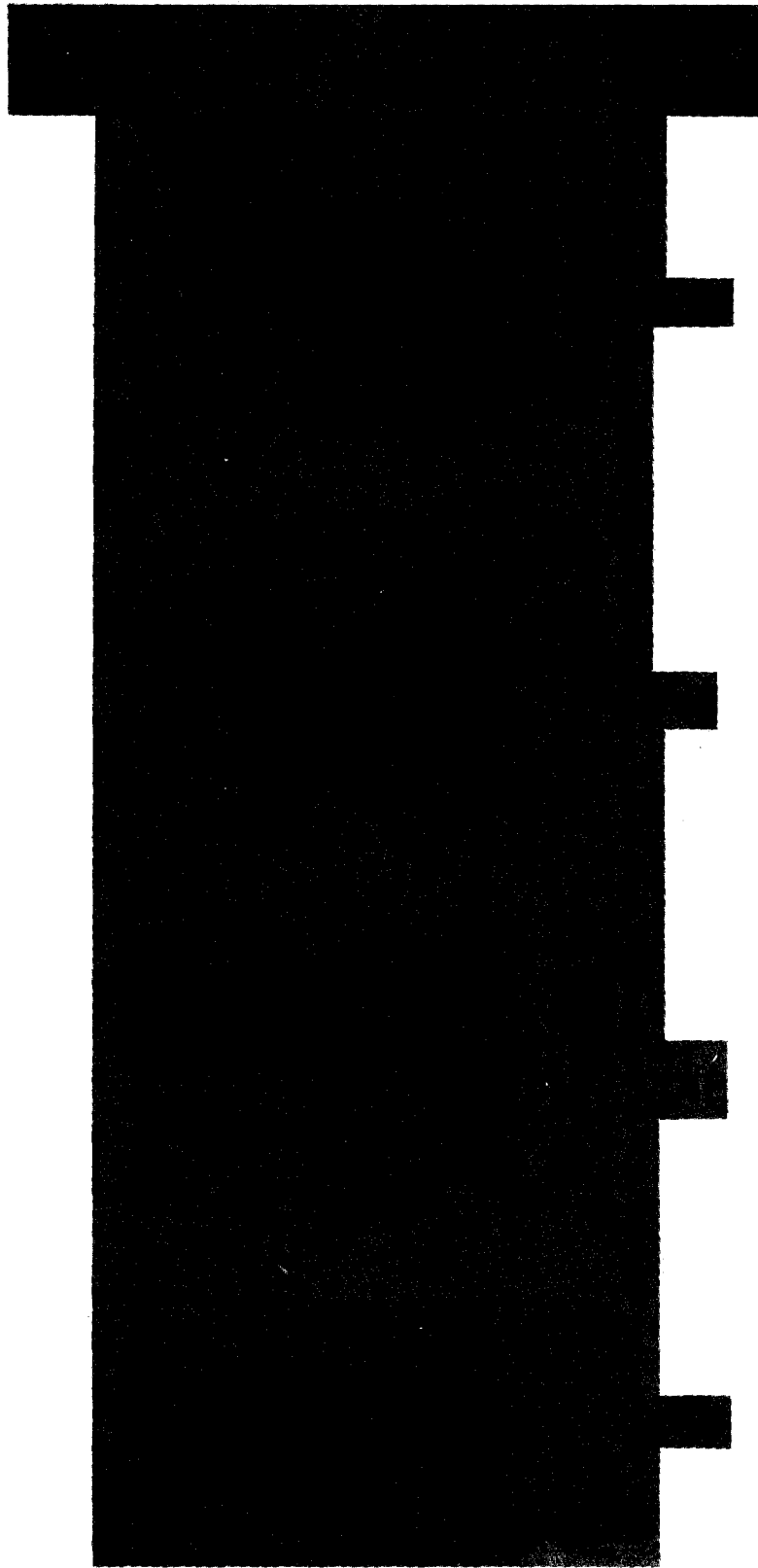

Fig 1-26 TYPICAL US ARMY FUZE
DETONATORS

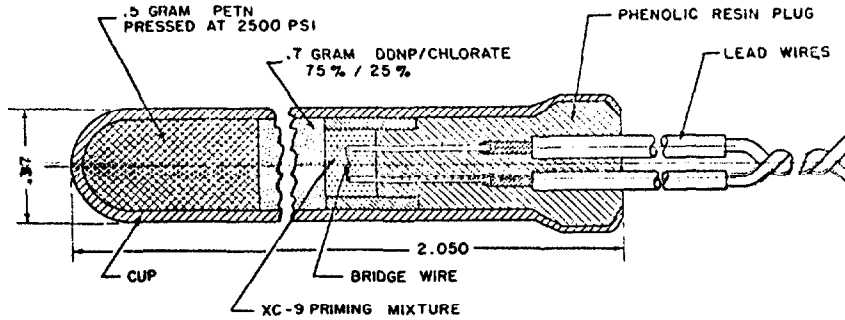

Fig 1-27 NAVY ELECTRIC DETONATOR
Mk46ModO

such as one contg LA 28.3, K chlorate 33.4, Sb sulfide 33.3 & carborundum 5.0%. Older types contained MF, such as: a) MF 32-35, K chlorate 45-35 & Sb sulfide 23-30% or b) MF 28, K chlorate 14, Sb sulfide 21, ground glass 35 & shellac 2%. There are also mixts that may be considered as derived from the chlorate-thiocyanate compositions by the inclusion of explosive ingredients: a) K chlorate 53, Pb thiocyanate 25, Pb sulfide 17 & LA 5%; b) K. chlorate 53, Pb thiocyanate 25, Sb sulfide 12 & PETN 10%; and c) K chlorate 37.05, Pb thiocyanate 38.13, Ba nitrate 8.68, TNT 5.69 & ground glass 10.45% (Ref 51d, p 7-17)

Section 4, Part D

c) Instantaneous Electric Fuze Detonators

Similarly to electric primers, (described in Section 4, Part E), these electric detonators may be made to fire from suitable sources of electrical energy, such as generators, batteries or charged condensers; they may thus be made to fire from an electric pulse supplied by energy stored within fuze firing circuit or by an electric pulse generated within the fuze system prior to or at impact

The electric detonator is ordinarily used to actuate a booster or *booster lead* (usually Tetryl). At the time of publication of NOLR 1111, which was 1952, electric detonators were used in Naval mine and torpedo firing mechanisms and to a limited extent in Army fuzes (See also Section 2, Part C, "History of Development of Detonators, etc")

Instantaneous electric detonators described in NOLR 1111 (Ref 23, pp 4-14 to 4-19) include Navy electric detonators Mk46 Mod O & Mk51 Mod O and Army detonator M36. They are shown here in Figs 1-27, 1-28 & 1-29, respectively

Mk46 Mod O Detonator consists of a gilding-metal cylindrical container (with a rounded base) loaded with PETN as a base charge, loose DAzDNPh/K chlorate-75/25 mixt as intermediate chge and XC-composition (75/25-DAzDNPh/K chlorate mixture milled with a soln of 2.4% NS in butyl acetate), serving as a flash (igniter) chge. Ignition chge is buttered inside fiber sleeve (ferrule) which surrounds the "tophet-C" bridge wire 0.00225 inch diam and 0.075 inch long. The single strand tinned Cu leading wires are attached with silver solder to the bridge and are molded within a phenolic plug. This detonator is sufficiently powerful to initiate a booster pellet directly (Ref 23, p 4-17)

Mk51 Mod O Detonator (Fig 1-28) consists of a long gilding-metal cylindrical container with a base designed to produce a shaped charge effect. The base chge of PETN is loaded in two increments, the one adjacent to intermediate chge of DAzDNPh is loaded at a lower pressure than the other. This arrangement allows the 1st increment to ignite more readily while the 2nd, being loaded at higher pressure gives greater output. The flash chge consists of XC-9 priming mixt which is buttered around tophet-C bridge

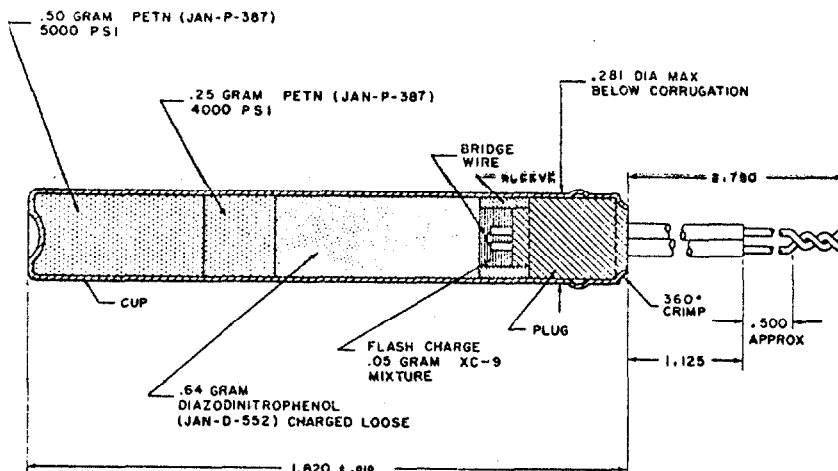

Fig 1-28 NAVY ELECTRIC DETONATOR
Mk51Mod0

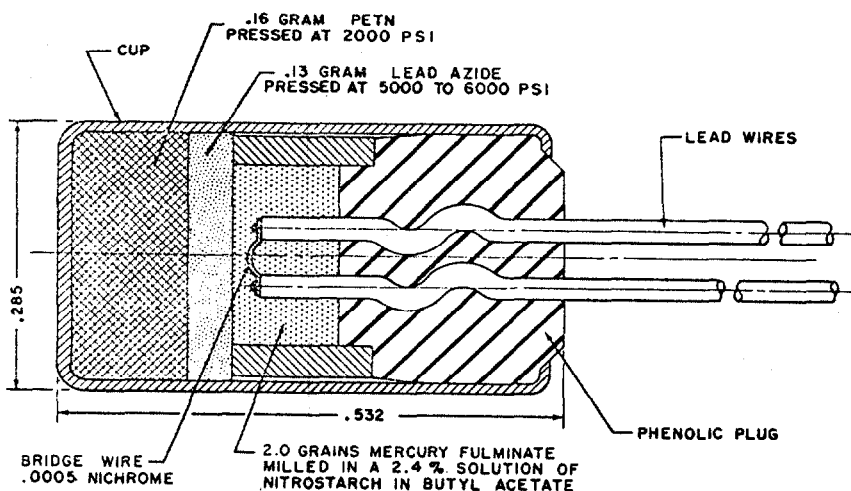

Fig 1-29 ARMY ELECTRIC DETONATOR M36

wire 0.0005 inch diam of proper length to give a resistance of 2 to 6 ohms. The leading wires and the plug are of the same design as for Mk46 Mod O (Ref 23, p 4-18)

Only one instantaneous US Army electric detonator is described in Ref 23. It is M36, which is, accdg to Tweed (Ref 42b, p 653), the first electric detonator developed by the Army Ordnance Corps when it was required during WWII to equip airplanes with electri-

cal systems to perform firing and fuzing tasks, such as in VT (Variable Time) Fuze, known also as Proximity Fuze. The cut of M36 given in Ref 23, Fig 4-7, p 4-19 is reproduced here as Fig 1-29. The detonator consists of a gilding-metal cup loaded with PETN as base charge, dextrinated LA as intermediate chge and 96/4-MF/NS mixture (colloided with butyl acetate) as ignition (flash) chge. The ignition chge is buttered inside the fiber tubing sleeve

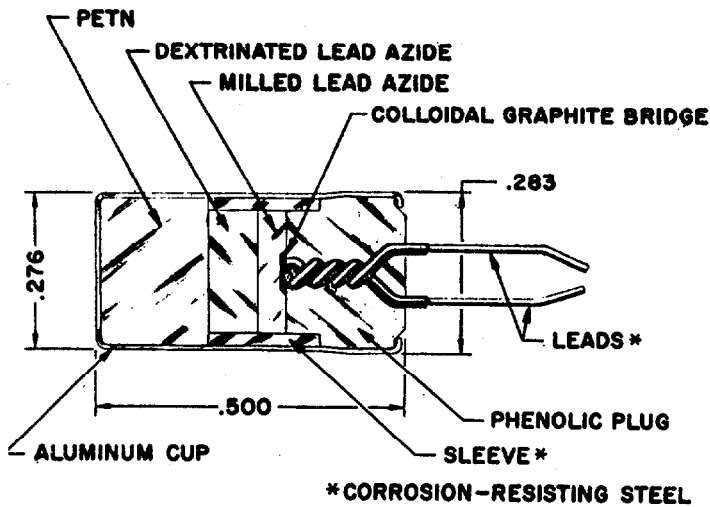

Fig 1-30 ARMY ELECTRIC DETONATOR M48

(serving as container and spacer) in such a manner as to surround the nichrome wire bridge 0.0005 inch diam, which is silver soldered to leading wires of tinned Cu. The wires are molded within a phenolic plug. This detonator was made to function within 1000 microseconds from the discharge of a 0.7 μ f condenser charge to 75 volts

Accdg to Tweed (Addnl Ref Ad 97c, p 653), the M36 was not stable in storage because its MF chge easily deteriorated. On replacing MF/NS with LSt and gilding-metal cup with Al cup, a detonator with improved shelf life was obt'd. This is known as M36A1 Electric Detonator

About the same time that the M36A1 was being developed, there was an urgent need for a device which could function from the electrical energy released by crushing a Ba titanate crystal in PIBD Fuze for HEAT Shell. The resulting detonator is known as M48 and is shown here in Fig 1-30. It consists of an Al cup loaded with PETN as base chge, dextrinated LA as intermediate chge and milled dextrinated LA as ignition chge. Both LA chges are placed inside a stainless steel sleeve (ferrule) which overlaps into phenolic plug. The bridge is of colloidal graphite and the leading wires are of stainless steel. The portions of wires inside the plug are coated with "Formvar" (Trademark for polyvinyl formal resins manufd

by Shawing Resin Corp, Springfield 1, Mass) and twisted to attain the small separation at the face of the plug needed for graphite bridge detonators. This detonator will function within 10 microseconds from the discharge of an 0.0022- μ f condenser charged to 300 volts (Ref 42b, pp 653-54)

M51 Electric Detonator is smaller than M48 (0.194-inch in diam by 0.37-inch long), but the reduction of space available for expl chge is partially offset by replacement of the pressed ignition chge with a spot of colloidal LA mixed with NC lacquer. This detonator has been used in safety and arming mechanism of Nike Ajax, which is an Army surface-to-air guided missile designed to seek and destroy enemy planes

T20E1 Electric Detonator has the same dimensions as M51 and consists of stainless steel wire leads, cup and ferrule, a phenolic plug, a tungsten wire bridge, (resistance 1000 ohms per foot), a colloidal LA spot chge, a dextrinated LA intermediate chge and a PETN base chge (See Fig 1-31 taken from p 655 of Ref 42b). The purpose of ferrule is to protect the bridge by taking the brunt of the pressure when the plug is pressed into the cup. The T20E1 will function within 10 microseconds from the discharge of a 0.4- μ f condenser charged to 50 volts. It has been used in Army surface-to-air missile Hawk employed against low flying planes

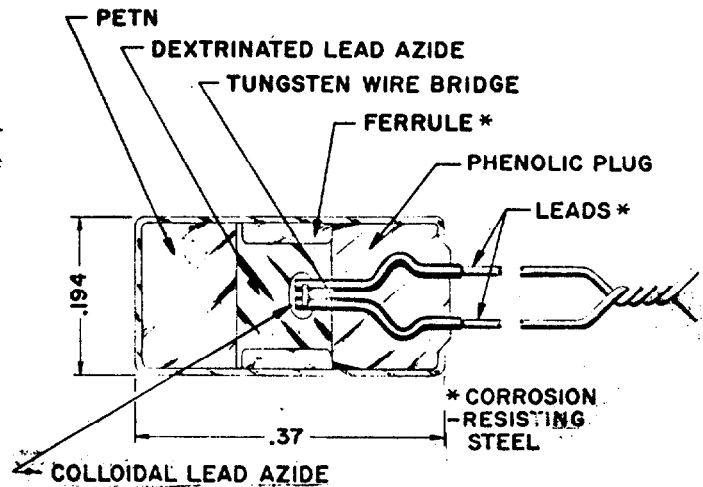

Fig 1-31 ARMY ELECTRIC DETONATOR T20E1

T44 Button-Type Electric Detonator, not shown here in drawings, consists of a stainless-steel cup of the same size as M44, but the 1/16-inch "button" increases its length from 0.375 to 0.425-inch. Inside the cup there are a pin, plug, ferrule, tungsten bridge wire (1780 ohms/foot) and expl chges: MNLSt (milled normal lead styphnate) serving as a spot chge placed betw pin and plug, DLA (dextrinated lead azide) as intermediate chge and PETN as base chge. The pin and the inside of the plug are coated with Formvar for insulation and then bonded together with Araldite. When assembled, the electrical circuit is completed by contact between the pin and any point in the cup. The T44 will function within 100 microsecs from the discharge of a 16- μ f condenser charged to 2.5 volts. It has been used in hand-grenade fuzes (Ref 42b, p 654)

T65 Electric Detonator was the first electric delay detonator released for production engineering studies. It consists of a stainless steel cup 0.244-inch in diam by 0.69-inch long and a button which increases its length to 0.75-inch (See Fig 1-32). The contents of cup include ferrule, pin, plug, carbon bridge, a MNLSt spot, a LMNR (lead mononitroresorcinate) spot cover, 70/30-Pb peroxide/boron ignition chge, a 90/10-Ba chromate/boron delay chge, a DLA intermediate chge and RDX base chge. The LMNR spot cover prevents

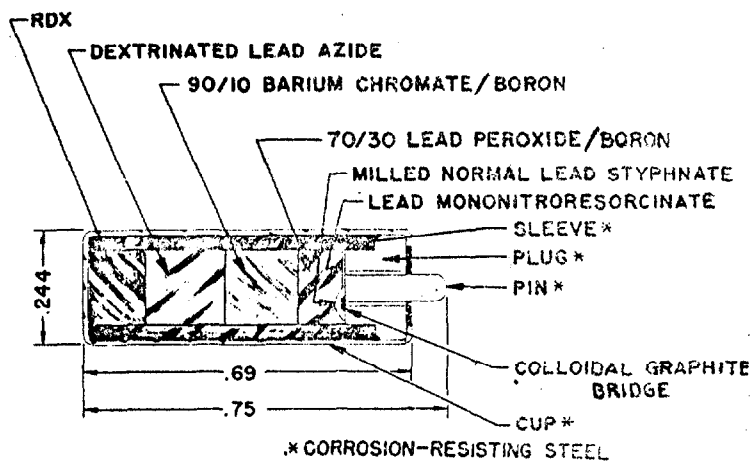

Fig 1-32 ELECTRIC DELAY DETONATOR T65

the PbO_2/B chge from shorting the pin and plug on the face not covered by the ignition spot. The T65 will function in a mean time of 50 millisecs \pm 5% from the discharge of a 0.004- μ f condenser charged to 100 volts. Its uses are not specified in Ref 42b, p 654

T29 Stab-Electric Detonator consists of a stainless-steel main cup 0.241-inch diam by 0.495 long and a stab cup which replaces the pin of a button-type detonator. The main cup contains CLA, DLA & PETN. The stab cup contains a disk next to NOL 130 Primer Mix (BLSt 40, Tetracene 5, Sb sulfide 15, Ba nitrate 20 & LA 20%), followed by DLA. A spot of colloidal graphite forms a bridge between the stab cup and plug. The stab cup is separated from the plug by Formvar and Araldite. The T29 will function electrically within 5 microsecs from the discharge of a 0.0022- μ f condenser charged at 300 volts; also by stab action from six inch-ounces of energy (Ref 42b, p 654)

T39 Electric Detonator is an example of a spark-gap detonator. It consists of a cup 0.194-inch diam by 0.37-inch long loaded with HMX as base chge, RD-1333 LA (See Vol 1 of Encycl, p A559) as intermediate chge and a small chge of CLA, which is placed on the phenolic plug against a small gap between the ends of two wires ground almost flush with the face of the plug. As the gap between the ends of wires is only 0.001-inch, there is an infinite resistance without using carbon bridge. The T39 will function with 10 microseconds from the discharge of a 0.001- μ f condenser charged at 1000 volts. It was planned to use T39 in the firing device of railroad type torpedo (Ref 42b, p 654)

T62 Button-Type Electric Detonator is one of the miniature series detonators recently developed. It consists of a stainless-steel cup 0.147-inch diam by 0.342-inch long. Total length with button is 0.410-inch. Its resistance bridge is of colloidal graphite and it is covered with CLA, followed by intermediate chge of DLA, and a base chge of RDX (See Fig 1-33, taken from Ref 42b, p 655). The T62 will function within 5 microsecs from the discharge of 0.0022- μ f condenser charged to 300 volts (Ref 42b, p 654)

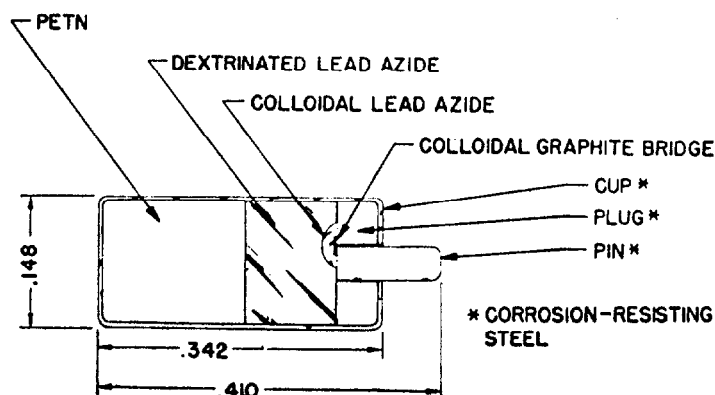

Fig 1-33 BUTTON-TYPE ELECTRIC DETONATOR T62

Until about 1960 it was considered that the minimum diameter for propagation of Tetryl, RDX and PETN in light confinement was 0.125, 0.100 and 0.050-inch respectively. The development, however, of MDF or LEDC [Mild Detonating Fuse or Low Energy Detonating Cord (See Ref 50, pp 106-07)], by the joint efforts of DuPont Co, Wilmington, Del and Ensign Bickford Products Division of Darworth Inc, pointed the way to decrease the ID to 0.020-inch or even lower. Their length may also be decreased by substituting some expl constituents by smaller chges of more powerful expls. For example 85 mg DLA used in M47 to reliably initiate 34 mg RDX in a column 0.128-inch surrounded by gilding metal can be substituted with 25 mg of PVA or RD-1333 LA. Some multiconstituent primer mixes can be replaced by a single expl, such as Cu chlorotetrazole (Ref 42b, p 655) (See also Vol 3 of Encycl, p C270-L)

A comprehensive description of current electric detonators is given by Freiwald (Addnl Ref Ad 160)

Section 4, Part E

Description of Instantaneous Fuze Primers

There are two types of fuze primers: "unobturated" and "obturated". Obturated primers contain an anvil, while unobturated do not contain it. Following are examples of unobturated fuze primers

a) Instantaneous Stab Fuze Primers

These primers consist of a thin metallic cup filled with a very sensitive priming mix-

ture and sealed with a thin disc. For activating, the disc is pierced with a thin, sharp firing pin and this results in explosion of priming mixture and complete destruction of primer



Fig 1-34 TYPICAL STAB FUZE PRIMER

The simplest primer of this type is shown in Fig 1-34 copied from Ref 17, Fig 13 on p 47. This primer cannot be used to detonate delay columns but is suitable for initiating detonators

Accdg to Ref 23, pp 3-1 to 3-10, stab primers are used by the US Navy to perform some mechanical work. For example, primer Mk102 Mod O (See Fig 1-35), can be used to expand the inner cup of the Mk2-type fuze and to drive a firing pin into the secondary primer. The US Army stab primers, of which types M26 & M45 are shown in Fig 1-35, can be used to ignite a BkPdr chge. Primer M45 includes an ignition chge within the stab primer assembly in addn to the priming chge. Although the American practice has been to use percussion type primers for the initiation of sealed delay elements, some foreign fuzes, examined in the US, had a stab primer enclosed together with its firing pin within delay element. In one such fuze initiation resulted from setback forces, while in another from impact forces

US Military stab primers consist of a cylindrical metallic cup varying in size from 0.16-inch diam by 0.100-inch length (Navy Primer Mk102) to 0.241-inch diam by 0.340-inch length (Army Primer M45). The sensitive end of Navy stab primers is closed by a very thin metal cover disk crimped into place. The closure of the opposite side may be of the same type (in this case the metal is turned over and the disk placed prior to loading), or the cup may have a closed end

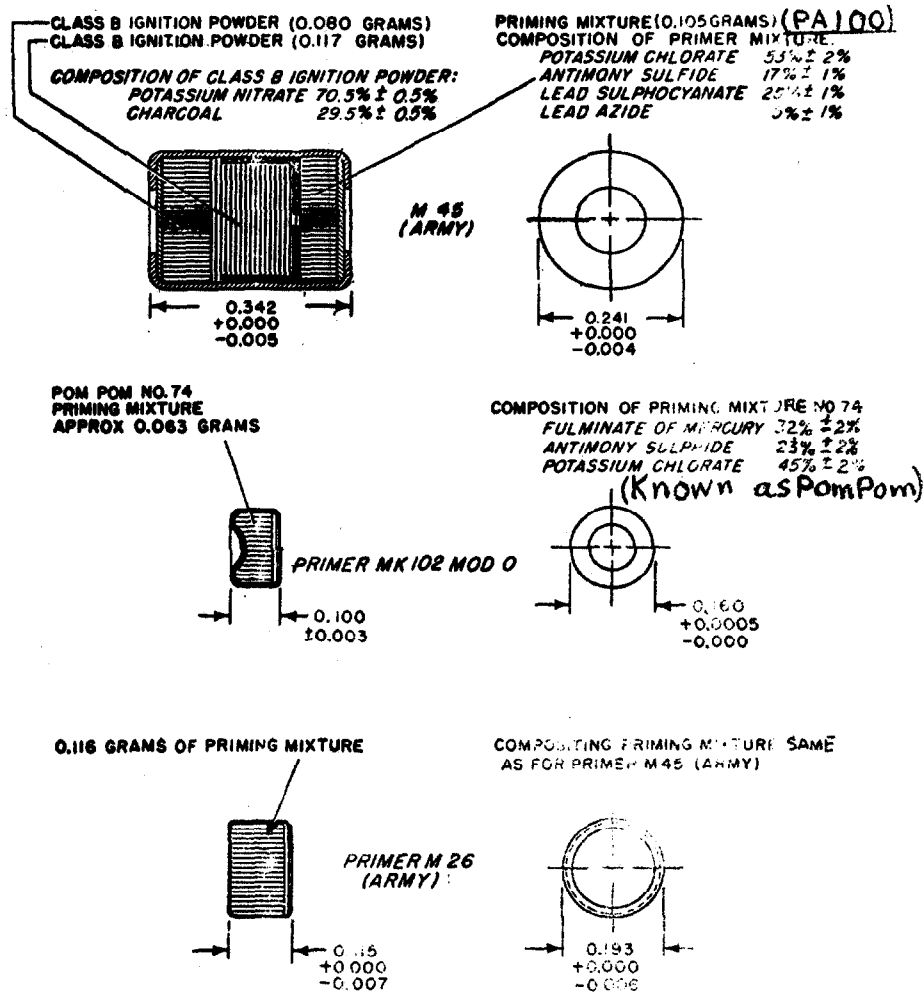

Fig 1-35 ARMY AND NAVY STAB FUZE PRIMERS

Stab primers are usually more sensitive than percussion primers; therefore, they can be used advantageously where little energy for initiating an expl train is available. Their disadvantage is that the hole pierced in housing by firing pin allows combustion products to escape, which is undesirable from the standpoint of pressure control and the possibility of fouling moving parts

In addition to compns of priming mixtures PA 100 & PomPom No 74, given in Fig 3-1 of Ref 23, there are some other mixts which are used in stab primers. They are listed on p 2-10 & p 3-2 of Ref 23:

a) OS 891 Mixture - K chlorate 45, Sb sulfide

22 & Pb sulfocyanate 33%

b) PA 70 Mixture - K chlorate 53, Sb sulfide 17, Pb sulfocyanate 25 & TNT 5%

c) LA Priming Mixture - K chlorate 33.4, Sb sulfide 33.3, LA 28.3 & Carborundum 5%

d) NOL No 130 Mixture - Basic Pb styphnate 40, Ba nitrate 20, LA 20, Sb sulfide 15 & Tetracene 5%

No single explosive has been used by itself in stab primers because none has been found that meets both the input and output requirements

Metals for the components vary with stab primer chge. Navy practice is to load mixts contg MF (such as PomPom No 74) into Cu or

Cu base alloys. Mixts contg LA are loaded into cups formed from Al or Al base alloys. In the Army stab primers listed above, the priming mixts are encased in a gilding-metal cup

Percussion fuze primers described below belong to "obtured" types

Section 4, Part E

b) Instantaneous Percussion Fuze Primers

Accdg to definition given in Ref 23, p 3-10 (slightly reworded): It is an initiating element containing an impact sensitive explosive charge arranged so that it will function when a round end (not sharp) firing pin dents, on striking the metal primer case, and pushes it against the anvil. This primer is of obturated type. The firing pin may be driven by mechanical forces resulting from spring action, gas pressure, inertia, or direct impact. The output of such primer is normally a flash or spit of low brisance. This type of primer is particularly suitable for use with sealed (obtured) delay elements, since initiation can be achieved without breaking the seal. Besides initiating delay columns (BkPdr and gasless), these primers can be used for initiating pyrotechnic devices. They have the limitation of requiring higher initiating energies than stab primers and detonators

The Navy fuze percussion primers described in Ref 23 include:

a) Navy Fuze Primer Mk101 Mod O, shown in Fig 3-5, p 3-11 of Ref 23 (See our Fig 1-38) has been used to ignite a BkPdr delay pellet or to cause initiation of detonator in Navy Base Detonating Fuzes Mk19 to Mk21, Mk28, Mk36, Mk48, Mk162

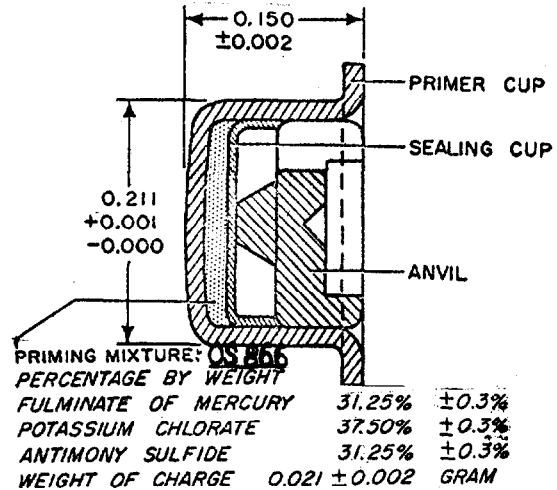

Fig 1-39 NAVY FUZE PRIMER Mk105ModO

b) Navy Fuze Primer, Mk105 Mod O, shown in Fig 3-5, p 3-11 of Ref 23 (See our Fig 1-39) has been used to ignite a BkPdr delay pellet in Navy Fuzes Mk228 Mod O, Mk243 Mod O and Mk244 Mod 1

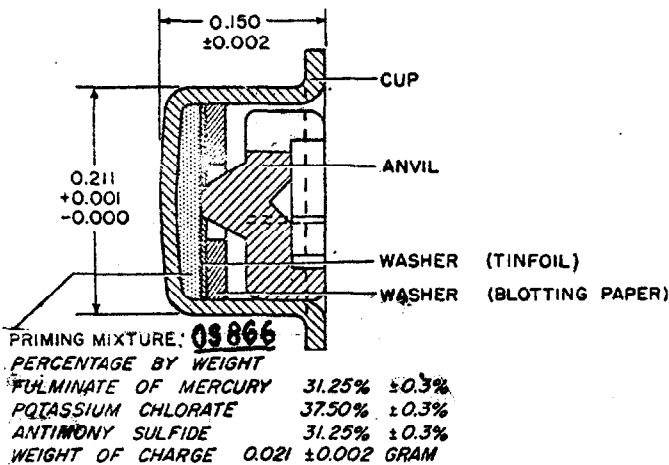

Fig 1-38 NAVY FUZE PRIMER Mk101ModO

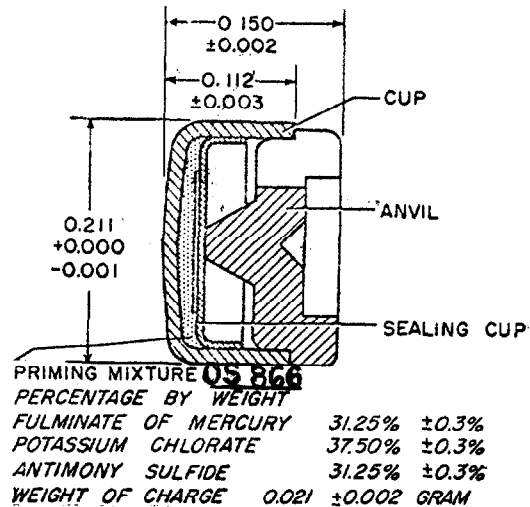

Fig 1-40 NAVY FUZE PRIMER Mk106ModO

c) Navy Fuze Primer, Mk106 Mod O, shown in Fig 3-7, p 3-12 of Ref 23 (See our Fig 1-40) has been used to ignite BkPdr delay element or to initiate a detonator in Navy Fuzes Mk145 Mods O & 1 and Mk165 Mod 1

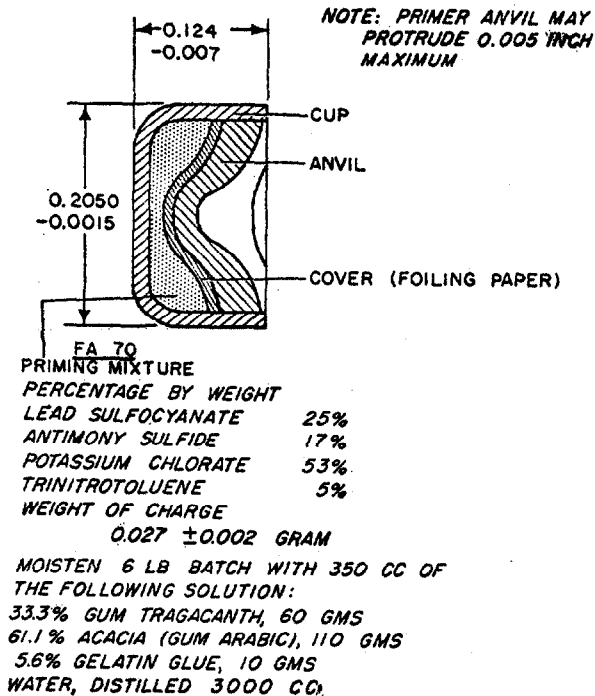

Fig 1-41 ARMY FUZE PRIMER M29

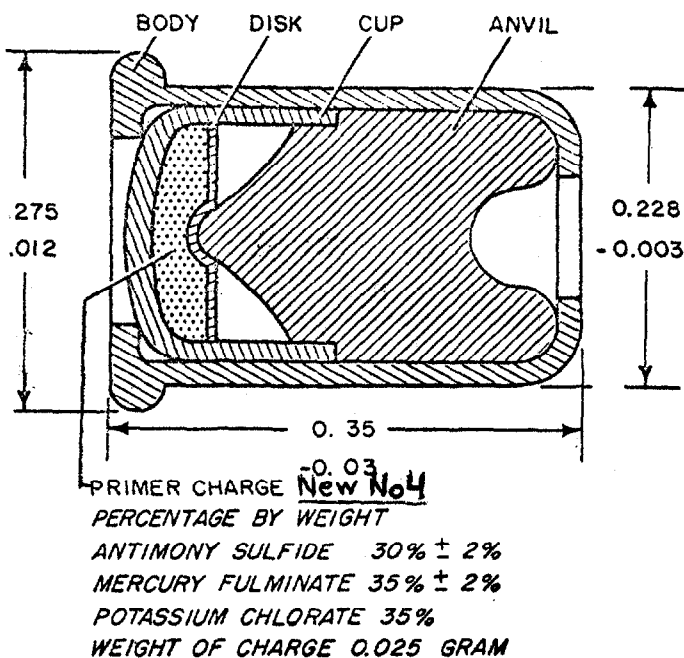

Fig 1-42 ARMY FUZE PRIMER, New No 4

d) Army Fuze Primer, M25, shown in Fig 3-8, p 3-12 of Ref 23 (See our Fig 1-41) has been used in Army Point Detonating Fuzes M48, M51 & M81; in Mechanical Time Fuzes M43 & M67; and also in Concrete Piercing Fuze M78. The function of the primer is to ignite a BkPdr delay pellet or BkPdr charge

The soln shown in Fig 3-8 for wetting FA70 seems to be in error, because it is given on p 2-10 as that used for wetting No 90A, while a different soln is given for FA70 (See below)

e) Army Primer, New No 4 (Percussion) shown in Fig 3-9, p 3-13 of Ref 23 has been used to ignite a BkPdr delay pellet in Army Bomb Fuzes M100 & M103. It is initiated by a firing pin driven by inertia upon impact of the bomb

Besides fuze primer compositions: OS 866 Fulminate Mixture (Navy), FA70 Wet Mixture (Army and Navy), and New No 4 Mixture (Army) listed in Figs 3-5, 3-6, 3-7, 3-8 & 3-9, (our Figs 1-38 to 1-42 incl) the following mixtures were also used (Ref 23, p 2-10):

- M27 Mixture (Army): K chlorate 28.5, Sb sulfide 27.0 & MF 44.5%
- OS 891 (Navy): K chlorate 45.0, Sb sulfide 22.0 & Pb sulfocyanate 33.0%
- M39 (Army): K chlorate 37.05, Ba nitrate 8.68, Pb sulfocyanate 38.13, TNT 5.69 & ground glass 10.45%
- NOL No 60 (Navy): Basic Pb styphnate 60, Ba nitrate 25, Sb sulfide 10 & Tetracene 5%
- No 90A (Army): K chlorate 53.0, Sb sulfide 12.0, Pb sulfocyanate 25.0 & PETN 10.0% (Moisten a 6 lb batch with 350 ml of the same mixt as listed in Fig 3-8 for Primer FA70. Solvent is evaporated after wet loading primer cups)
- FA70 Wet Mixture (Army & Navy): K chlorate 53.0, Pb sulfocyanate 25 & TNT 5%. This compn is the same as given in Fig 3-8, but the wetting gum soln given on p 2-10 is different. It consists of gum tragacanth 120 grams in 3668 ml H₂O, a cacia (gum arabic) 220 g in 3668 ml H₂O, glue (1½ Test Copper's Std) 20 g in 332 ml H₂O & thymol, USP 2g in 20 ml 95% ethyl alcohol
- FA70A Wet Mixture (Army & Navy). The compn is the same as of FA70, but the gum mixture consists of Na alginate 60 g, glue (1-1/4 Test, Copper's Std) 40 g, H₂O 6000 ml

& thymol 10 g in 100 ml ethyl alcohol

h) FA675 (Army): Ba nitrate 82 & red phosphorus 18%. It is wetted with gum mixt described above for FA70 (item e)

i) FA675A (Army: Same compn as above but the gum mixt is that described above for FA70A (item f)

j) FA716 (Army): Ba nitrate 77, red phosphorus 18 & TNT 5%. It is wetted with gum mixt described above for FA70 (item e)

No single explosive has been used by itself in percussion primers because none has been found that meets both the input and output requirements. As can be seen from compns listed above, the usual ingredients are a primary expl, an oxidizer, a fuel, and, in some cases, an abrasive. Some mixts are made of nonexplosive components, such as a fuel and oxidizer with or w/o abrasive

The primer cup, or body, is constructed of a metal having a specified thickness and hardness such that when the bottom, or dome, of the primer is struck with a nonsharp firing pin, the primer will be initiated without rupture or blow-back at the point of detonation. The components of Navy percussion fuze primers contg MF usually consist of a Cu (or cartridge brass) primer cup, a tin (or Cu) sealing cup or disk, and a tin-plated brass anvil. Cartridge brass and gilding-metal is used by the Army for primer cups contg MF

More detailed descriptions of construction and properties of fuze percussion-primers are given in Ref 23, pp 3-13 to 3-22

Section 4, Part E

c) Instantaneous Electric Fuze Primers

Accdg to definition given in Ref 23, p 3-22 (slightly reworded): It is an initiating explosive - train component fired by an electrical impulse supplied by the energy either stored within the fuze before release of the missile, or generated within the fuze system just prior to or at impact of the fuze. An electric primer serves to initiate the next component of the train which can be either a detonator or delay element

Electric primers possess many advantages over either the stab or percussion primers, as can be seen from description given in Ref

23, p 3-23. Their disadvantages are listed in Ref 23, p 3-24

The instantaneous electric primer consists of an ignition element and a base chge assembled to form a single unit. The ignition element consists of the wire leads or contacts molded into a plug, the bridge fastened to these contacts, and a means of surrounding this bridge with a suitable ignition expl mixt. The base chge usually consists of a sensitive expl which is pressed into a cup and is capable of being initiated by the flash from the ignition element and the base chge must be sufficient to initiate the next element in the fuze train. There are a number of mixts suitable for use in the ignition elements of electric primers, but at the time of publishing NOLR 1111, which was 1952, only the following two compns were used in Naval fuzes (Ref 23, p 3-25 and p 2-10):

- a) XC-9: DADNPh 75 & K chlorate 25% ground in a 2.4% soln in butyl acetate
- b) XS-1A Navy Gun Primer: Normal Pb styphnate 98 & NC 2%

For the base chge, Primers Mk112, 113, 114 & 121 used DADNPh/K chlorate - 75/25 and some exptl primers used LA base charge

Metals for components of electric primers are chosen to be compatible with the expls used. In primers using XC-9 compn or Pb styphnate, Cu is suitable (unless moisture is present), while in primers contg LA either Al or stainless steel must be used to avoid formation of "supersensitive" Cu azide

Following are examples of Navy electric fuze primers:

a) *Electric Fuze Primer, Mk112 Mod O* is shown in Fig 3-14, p 3-27 of Ref 23 and reproduced here as Fig 1-43. Its "ignition subassembly" consists of a primer plug, a bridge wire attached by soldering to two copper leading wires, a fiber flash chge holder, a flash chge, and a primer plug of phenolic molding compd. The "tophet C" bridge wire is 0.0005 inch diam, the flash compn is ca 60 mg of XC-9 and the base chge ca 60 mg of DADNPh/K chlorate - 75/25

b) *Electric Fuze Primer, Mk121* is shown in Fig 3-15, p 3-28 of Ref 23 and reproduced here as Fig 1-44. The ignition subassembly closely

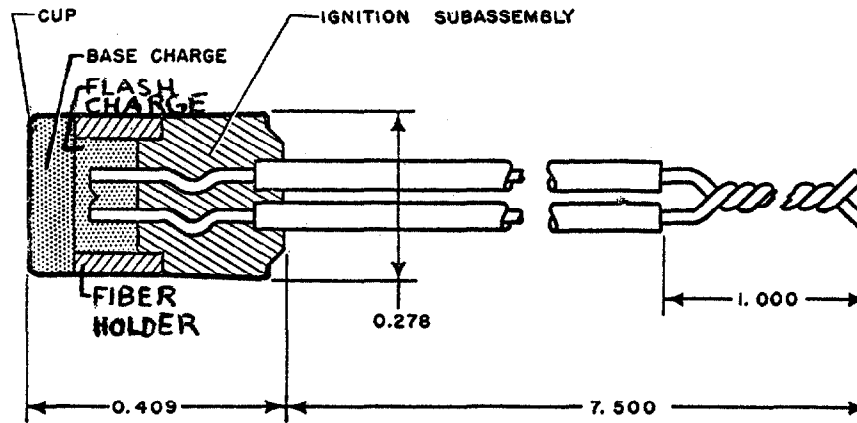

Fig 1-43 NAVY ELECTRIC FUZE PRIMER
Mk112ModO

resembles that of Primer Mk112, the major difference being the replacement of the metallic bridge wire by the conductive carbon path (bridge). The bridging of the gap between two insulated lead wires is accomplished by applying an "aquadag" with a wire loop, keeping the coated area as small as possible, and then drying rapidly under an infra-red lamp. The fiber charge holder is then put on and the ignition charge, consisting of 1.5 mg of a mixt of ground Pb styphnate and clear lacquer, is

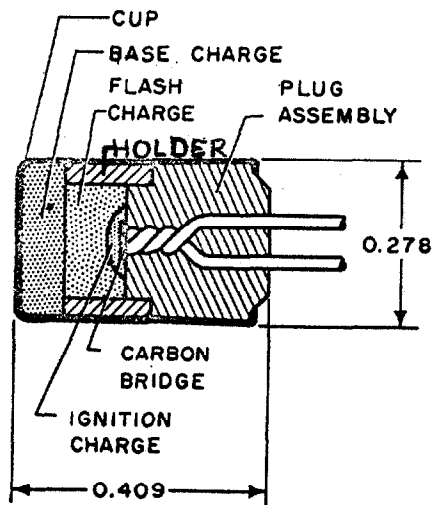

Fig 1-44 NAVY ELECTRIC FUZE PRIMER Mk121

applied over the bridge with a wire loop. After evaporating the solvent, the flash charge XC-9 (ca 60 mg) is buttered in and the assembly is dried. The base charge is the same as for Mk112

3) *Naval Experimental Spray Metal Electric Primer.* It is shown in Fig 3-13, p 3-26 of Ref 23 and reproduced here as Fig 1-45. The ignition element of this primer consists of a primer plug, the bridge wire attached by "spray" metal, the charge holder, and the flash charge pressed in the charge cavity. The primer plug consists of a phenolic molding compd contg. two tempered phosphor-bronze or brass contact prongs. Before "spraying" operation (which was originated at NOL), the end of the plug which is inserted into the primer housing is roughened in order that the spray metal will adhere to it more readily. Then the fine bridge wire is placed on roughened surface of the plug, touching the exposed surfaces of prongs. A stream of atomized molten metal is directed toward the wire at the place where it meets the prongs. The solidifying metal attaches itself to both the prong and the wire, forming the necessary junction. The length of wire required for the bridge is shielded from the spray metal. Then the charge holder and the washer necessary to insulate it from spray metal are forced down on the plug nose and the cavity is loaded with 5 mg of ignition charge (dry Pb styphnate pressed at 3400 psi). The base charge

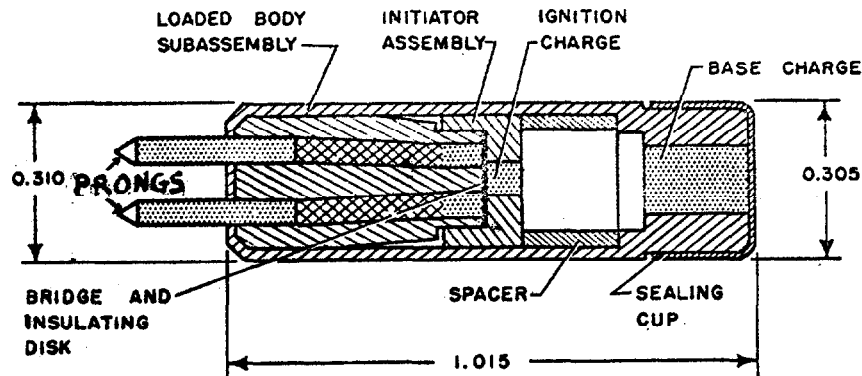

Fig 1-45 NAVY EXPERIMENTAL SPRAY
METAL ELECTRIC FUZE PRIMER

for instantaneous fuzes consists of 100 mg dry LA pressed into 0.1250 inch diam hole under 65000 psi

The "spray metal" technique was invented in order to obtain good contact between extremely thin and short bridge wires and leads. Such bridges are used in newer type electric primers which are capable of being actuated by an extremely small energy input

Section 4, Part F

Delays, Relays, Leads and Their Uses in Fuze Detonators, Fuze Primers and Some Pyrotechnic Items

a) Definition of Terms

A brief definition of the following terms is given in Vol 3 of Encycl (Ref 48): Delay (p D49-R), Delay Blasting Cap (p D49-R), Delay Charges (p D50-L), Delay Element (p D52-L) and Delay Explosive Train (p D53-R)

In the write-up which follows, a more detailed description (together with cutaway views) of the delay elements and of their function in detonators is given. Included are also definitions of "relays" and "leads"

Definition of a *relay* as given by Odierno of PicArns (Ref 45d, p I) is: "An element of a fuze explosive train which augments an outside and otherwise inadequate output of a prior explosive component so as to reliably initiate succeeding train component. Relays, in general, contain a small single charge such

as Lead Azide and are not usually employed to initiate high explosive charges"

This is essentially the same as definition given in Ref 40a, p 120, which says that relay is: "An explosive train component that provides the required energy to reliably initiate the next element in the train. Specifically applied to small charges that are initiated by a delay element and in turn cause functioning of a detonator"

The terms "delay" and "delay element" are not listed by Odierno in Ref 45d, among components of explosive train and their definitions are not given but the term *lead* is defined as: "An explosive train component which consists of a column of high explosive, usually small in diameter, used to transmit detonation from one detonating component to a succeeding high explosive component. It is generally used to transmit the detonation from a detonator to a booster charge. The accepted practice is that the lead should be slightly larger in diameter than the detonator to assure the correct explosive train propagation. A lead smaller in diameter than the detonator may not initiate the subsequent explosive components, such as a booster pellet even though the detonator is perfectly satisfactory for the purpose intended (Ref 45d, pp I & IIF)

Definition of *lead* given in NOLR 1111 (Ref 23), p 6-1 is as follows: "A lead is that explosive component of the firing train of a fuze which is located between the detonator

and the booster. The transmission of detonation from a detonator to a booster may involve propagation across a variety of discontinuities, such as air gaps and/or metal disks or walls, and through constricted channels "(See description of leads at the end of this Section)

In addition to brief descriptions of delays, delay elements etc given in Vol 3 of Encycl, the following info derived from NOLR 1111 (Ref 23), pp 5-1 to 5-17 is included:

"Delays, as used in missile fuzes, are usually employed to secure enhanced damage by allowing the missile to penetrate the target to the optimum depth. They may also be used in a wide variety of operations when it is desired to have one operation follow another after elapse of preselected time interval"

Delays may be incorporated into an explosive train in the form of a unit called *delay element* or *delay element assembly*. This unit generally consists of a primer, baffle, delay body (contg the delay charge), and some sort of auxiliary chge at the terminal end of the delay column to transfer the burning impulse to the next item in the train. In some cases, one or more of the above items may be omitted. The auxiliary chge may consist of a BkPdr chge, a detonator, or some other expl chge, depending on the requirements of the next item in the train. This chge may or may not be loaded into the delay body cavity

Delay elements may be classified accdg to the type of chge employed, such as black powder delays, gasless delays, and delays employing various other materials. Following are examples of delay elements.

Section 4, Part F

b) Black Powder Delay Elements

As BkPdr burns with evolution of gases, the burning rates of these elements are affected by pressure. If these gases are confined and not allowed to escape, the delay element is said to be *obtured* and if the gases are allowed to escape the element is said to be *vented*. There are also *pressure type delays*. BkPdr delay element may be further classified as *column* and *ring* types, depending on the shape of delay cavity contg the chge

By proper control of BkPdr composition and granulation, it is possible to obtain delay times from 4 milliseconds to 1 minute, but the range for individual elements is not so wide

In the Figs which follow, some BkPdr delay elements and delays used in US Navy and Army fuzes are shown

The elements A & B of Fig 1-46 are obturated column types, while C is vented column type, D vented ring type and E pressure type delay (Ref 23, pp 5-1 to 5-18)

In the element A (Fig 1-46), the firing pin on being actuated, fires the percussion primer, which spits into the expansion chamber and ignites the delay column without rupturing the primer cup. The column burns cigarette fashion, the gases being held in the expansion chamber, the primer cup, and the burned out part of the delay column. At the terminal end of the column the burning BkPdr ignites the *relay* detonator. The time range of element A is 0.01 to 0.4 sec. It has been used in contact (impact) initiated projectile and bomb fuzes of HE and AP types

Delay Element B (Fig 1-46) is also column type, but it is provided with a *baffle*. The function of the baffle is explained in Glossary, Section 2, Part A

Delay Element C (Fig 1-46) is also column type but it is vented. The vent serves for the escape of primer and delay column gases. The time range of this element is 0.50 to 10.0 seconds. It has been used for fixed time aerial bursts, such in flares

Other column type delay elements are shown in Figs 1-47, 1-48, 1-49, 1-50, 1-51 & 1-52, taken from Ref 23, pp 5-4 to 5-9

In Fig 1-47, is shown (in firing position), the Delay Element, Obturated Column Type, with Baffle. Its chge consists of 0.05 g A-5 BkPdr loaded in place in single increment at 81000 psi. Delay time 0.033 sec; use - in Navy BD Fuze Mk21 Mod 1.

In Fig 1-48, is shown Delay Element, Obturated Column Type, Without Baffle. Its chge consists of 0.09 g D-55 BkPdr loaded in 3 equal increments at 65000 psi. Delay time 0.33 sec; use - in Navy Bomb Fuzes MkXXI Mod 2 and MkXXII Mod 2

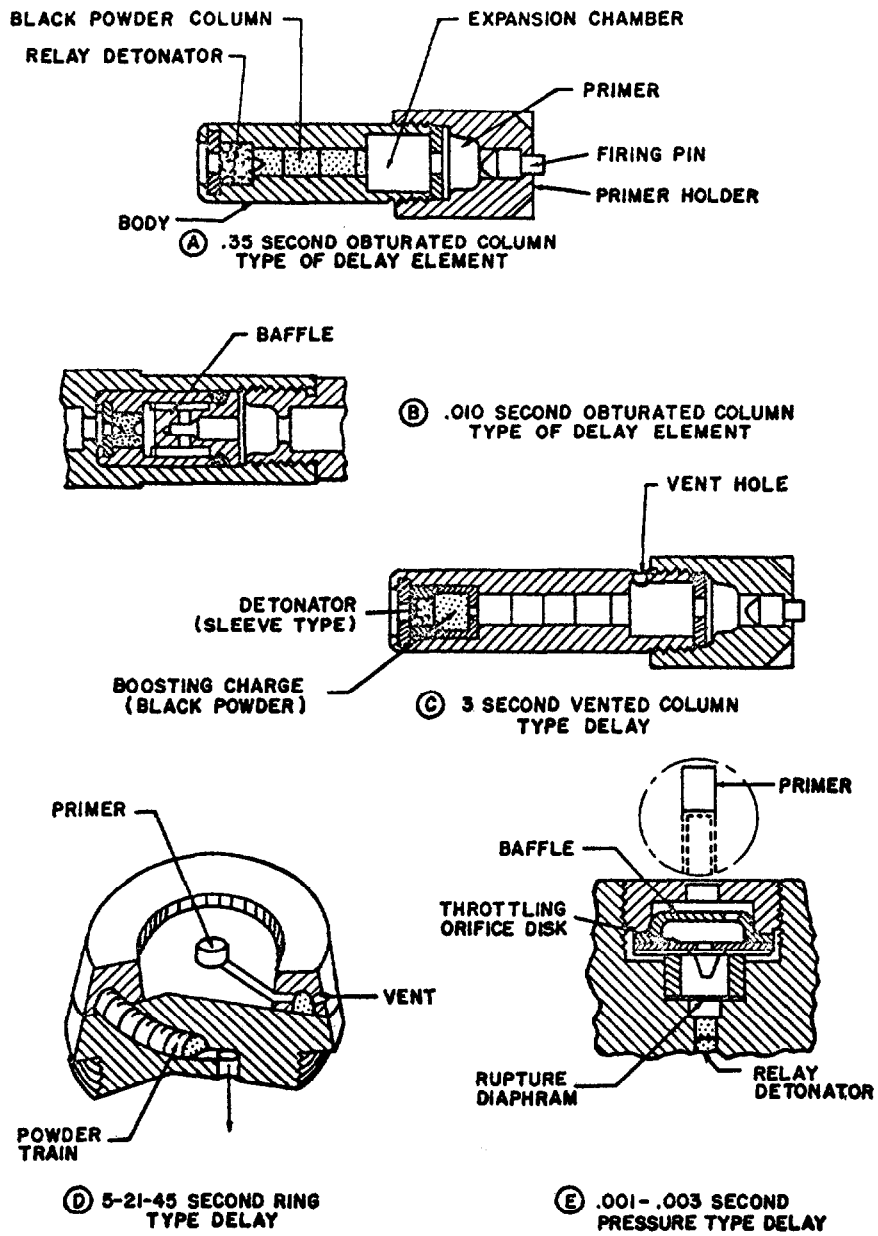

Fig 1-46 ARMY AND NAVY DELAY ELEMENTS AND DELAYS

D 859

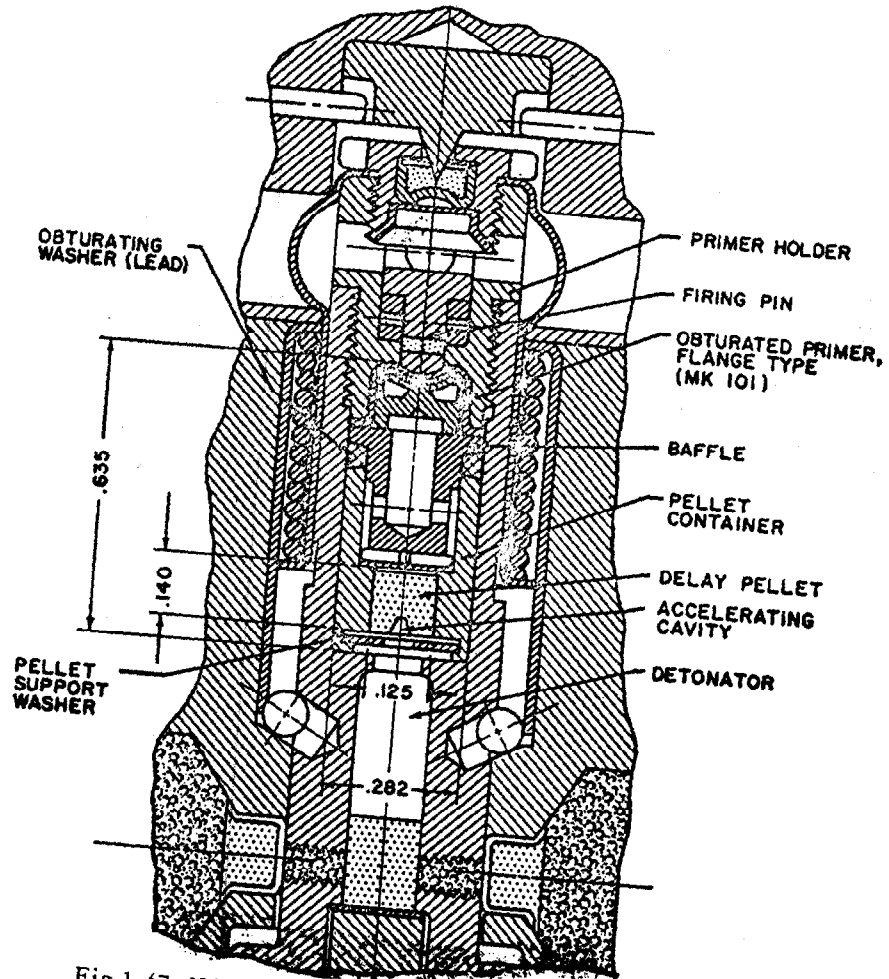

Fig 1-47 NAVY DELAY ELEMENT, OBTURATED COLUMN TYPE WITH BAFFLE

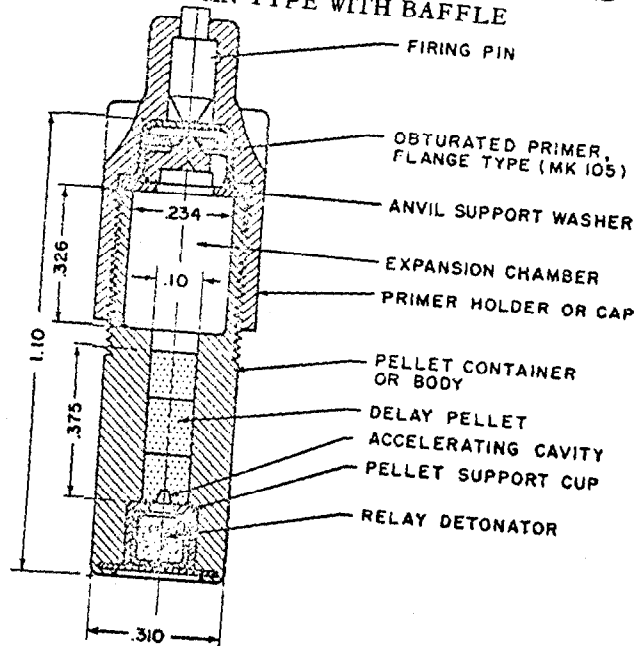

Fig 1-48 NAVY DELAY ELEMENT, OBTURATED COLUMN, W/O BAFFLE

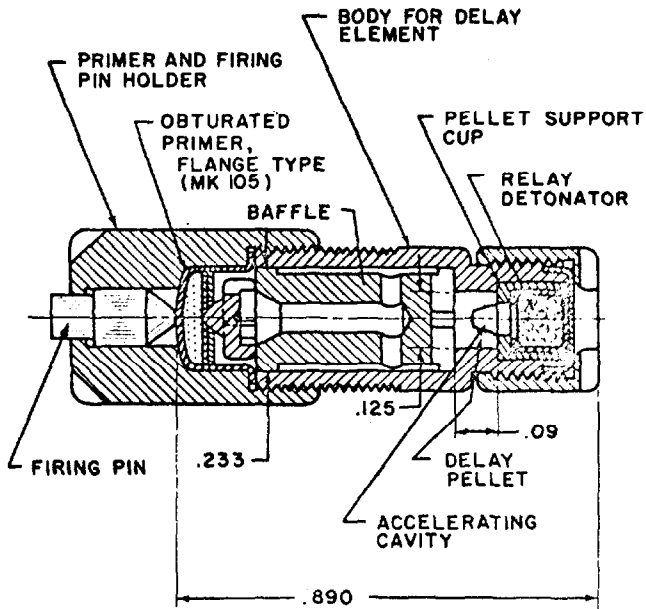

Fig 1-49 NAVY DELAY ELEMENT, OBTURATED COLUMN TYPE, WITH BAFFLE

In Fig 1-49 is shown Delay Element, Obturated Column Type, With Baffle. Its chge consists of 0.025 g Meal D BkPdr loaded in a single increment at 65000 psi. Delay time 0.010 sec; used in Navy Bomb Fuze Mk221 and Mk223.

In Fig 1-50 is shown Delay Element, Obturated Column Type, Without Baffle. Its chge consists of 0.065 g A-5 BkPdr loaded in a single increment at 65000 psi. Delay time 0.010 sec; used in Army BD Fuze M68

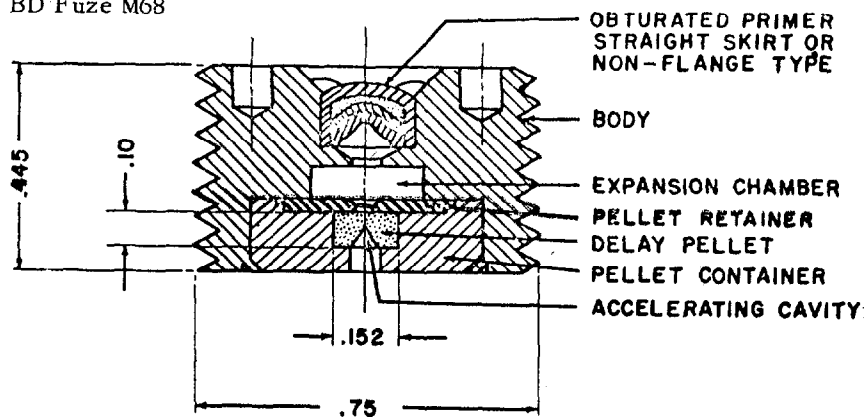

Fig 1-50 ARMY DELAY ELEMENT, OBTURATED COLUMN TYPE, W/O BAFFLE

In Fig 1-51 is shown Delay Element, Obturated Column Type, Without Baffle, used in Army Bomb Fuze AN-M100A2

In Fig 1-52 is shown Delay Element, Obturated Column Type, With Baffle, used in Army Point Detonating Fuze M48A2

Delay Element D in Fig 1-46 is ring type with time range 1.0 to 45 secs. Here the BkPdr chge is pressed directly into the metal component (*powder ring*) of the fuze. This type of delay had wide application in demolition devices and in aerial burst fuzes of AA (anti-aircraft) projectiles, but now is largely supplanted by clockwork mechanisms. In Fig 5-11 of Ref 23, p 5-14 (See our Fig 1-53), is shown an Army Fuze of 1918 in which such ring type delay was used. The same fuze is shown as Fig 5-17, p 5-38 of Ref 54 as one of the pyrotechnic items. In this delay, time is selective 1 to 21 secs. Loading: upper ring 3.185 grains, lower ring 3640 grains A-7 BkPdr is loaded in place in a single increment at 68000 psi

Delay Element E (Fig 1-46) is known as *Pressure Type* because it utilizes the pressure evolved by burning BkPdr to achieve short delays, such as 0.001 - 0.006 sec, which are difficult to obtain with other types of delay elements. The principle involved in this element is a rapid build-up in pressure which terminates in rupturing a disk or diaphragm. The type represented in Fig 1-46 is *nonobturated (vented)*, but there are also "obtura-

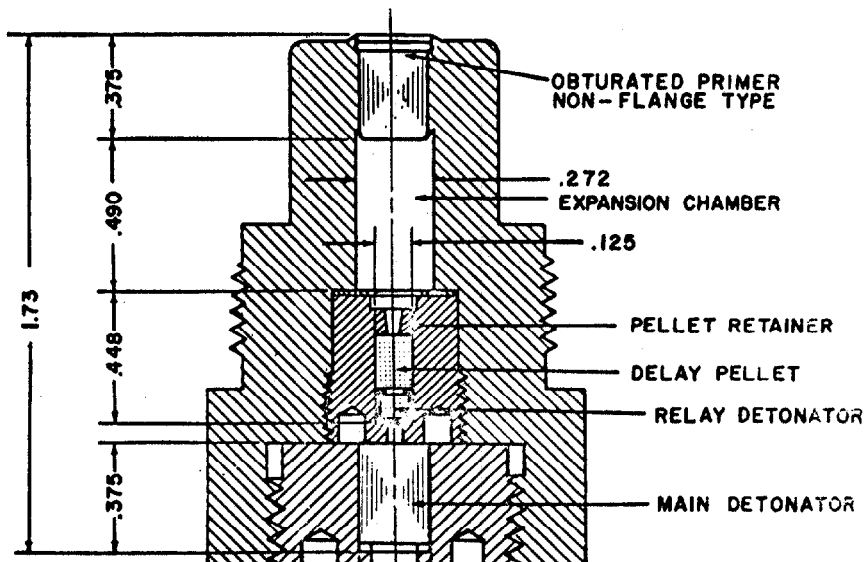

Time:
 0.010 Second
 .025 Second
 .100 Second

Loading:
 0.005 Gram A-5 Black Powder
 .013 Gram A-5 Black Powder
 .066 Gram A-5 Black Powder

Each Loaded in Place in Single Increment at 60,000 psi

Fig 1-51 ARMY DELAY ELEMENT, OBTURATED COLUMN TYPE, W/O BAFFLE

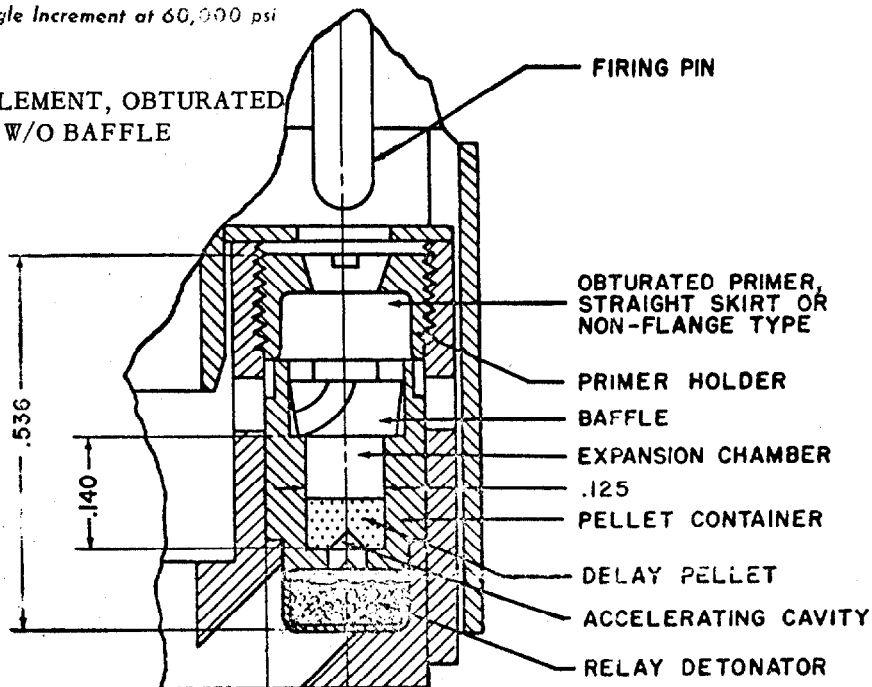

Time:
 0.05 Second
 .15 Second

Loading:
 0.033 Gram A-5 Black Powder
 .046 Gram Black Powder (Approx
 80 Percent Slow Burning Black
 Powder and 20 Percent Fuze
 Powder Type I)

Each Loaded in Place in Single Increment at 60,000 psi

Fig 1-52 ARMY DELAY ELEMENT, OBTURATED COLUMN TYPE, WITH BAFFLE

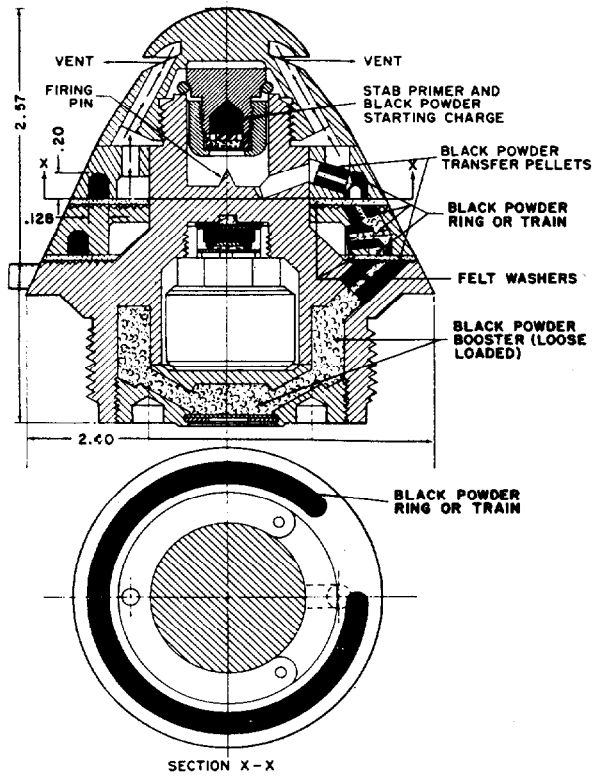

Fig 1-53 VENTED TIME DELAY RING OR TRAIN W/O BAFFLE

ted pressure type "delay elements. The essential features of element E are a *baﬄe* (See in Glossary, Section 2, Part A) a throttling orifice (0.035 inch diam), a lightly pressed (ca 4000 psi) BkPdr chge and a rupture diaphragm. In operating, the BkPdr chge is ignited by primer thru the throttling orifice and as the chge is not highly compressed it burns rather rapidly as a mass and not in train fashion. The gases evolved build up pressure sufficient to rupture the diaphragm, although some gases escape at the same time thru the throttling orifice

The "pressure type" delay element, which had been successfully tested in a PD fuze for British 2 Pounder AA Ammunition is shown here in greater detail in Fig 1-54, taken from

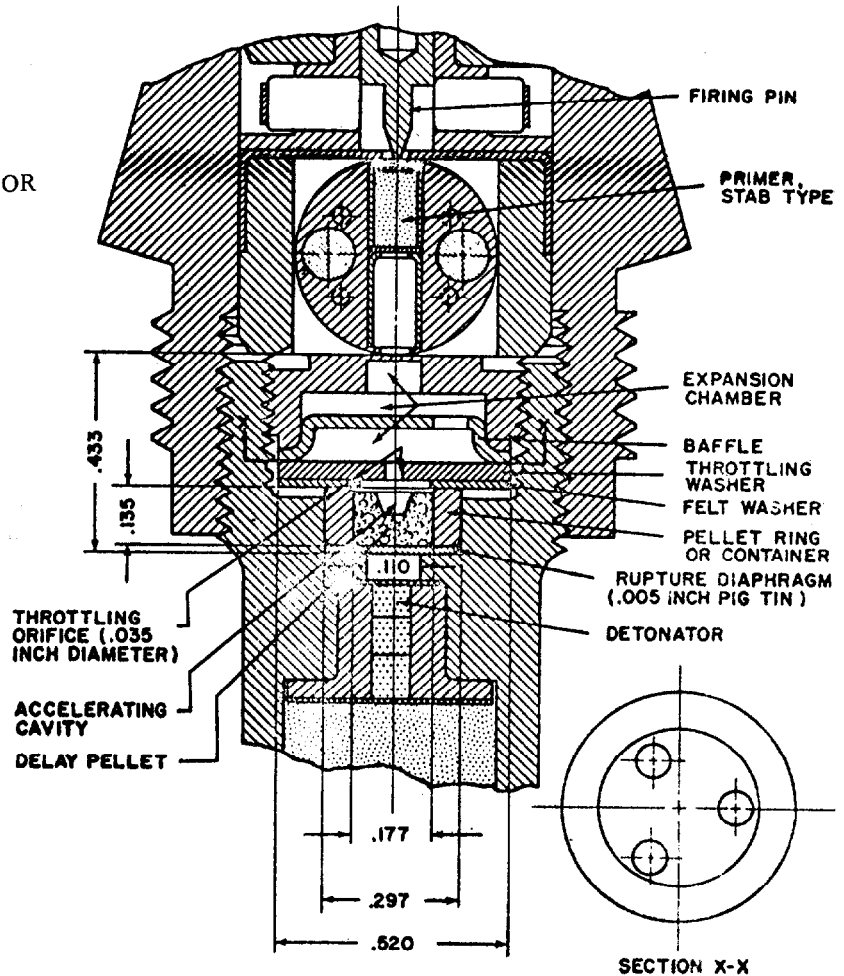

Fig 1-54 PRESSURE TYPE, VENTED DELAY ELEMENT, WITH BAFFLE

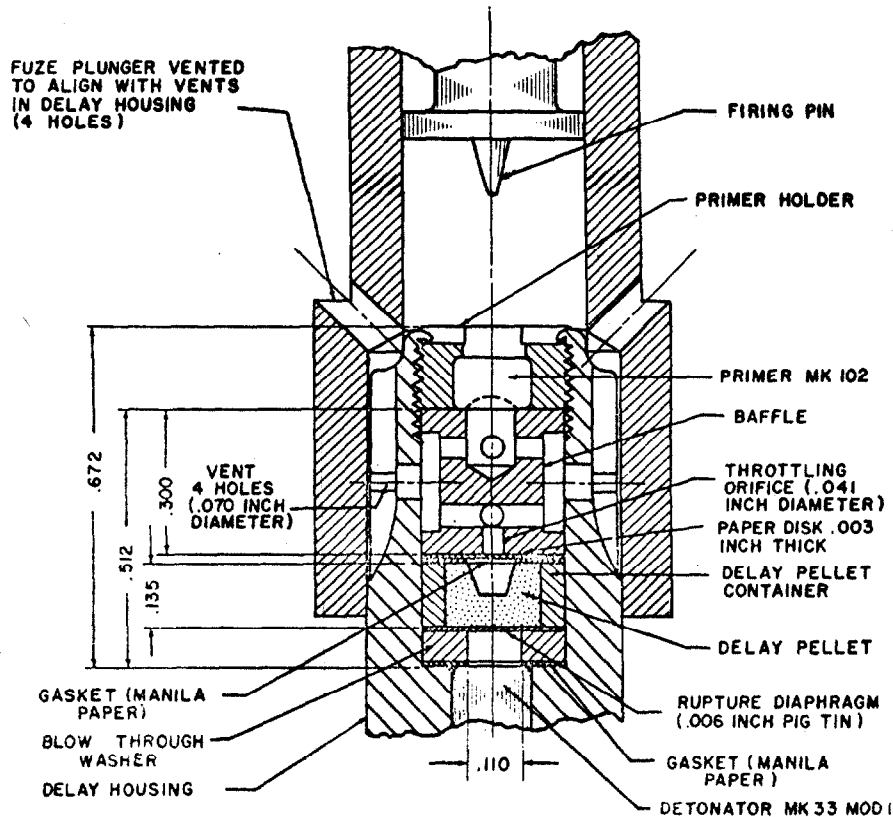

Fig 1-55 PRESSURE TYPE, VENTED DELAY ELEMENT WITH BAFFLE

Ref 23, p 5-16. It contains 0.073 g A-5 BkPdr loaded in place in a single increment at 4000 psi. Delay time 0.001 to 0.003 sec

Another form of pressure type delay element is shown in Fig 5-13, Ref 23, p 5-17 (See our Fig 1-55). It was designed for a Navy experimental fuze to provide a delay of ca 0.004 sec. It is similar to the British element, except that the housing is provided with four radial holes and connecting slots leading from the interior to a space in the fuze. This venting is for the purpose of relieving the pressure of the exploding primer which, due to its proximity to the BkPdr chge, would otherwise cause instantaneous action of the delay. It contains 0.073 g A-5 BkPdr loaded in place in a single increment at 5000 psi. Delay time 0.002 to 0.006 secs

Section 4, Part F c) Gasless Delay Elements and Detonators Employing Them

Accdg to Ref 23, p 5-49, the problem of handling the gases produced by the burning of conventional delays is often a difficult one for the fuze designer, since pressure affects the burning rate of such materials. This problem is much less serious in the case of gasless delays, because the amount of gas produced is small and the burning rate is less sensitive to pressure. This superiority of gasless delays is more apparent in the case of the longer delay times, and, hence, they have been more widely applied where the required delay is one second or more

Gasless delay assemblies fall into two general types, *obtured* and *non-obtured*. The choice of type usually depends upon the method of initiation. For example, the

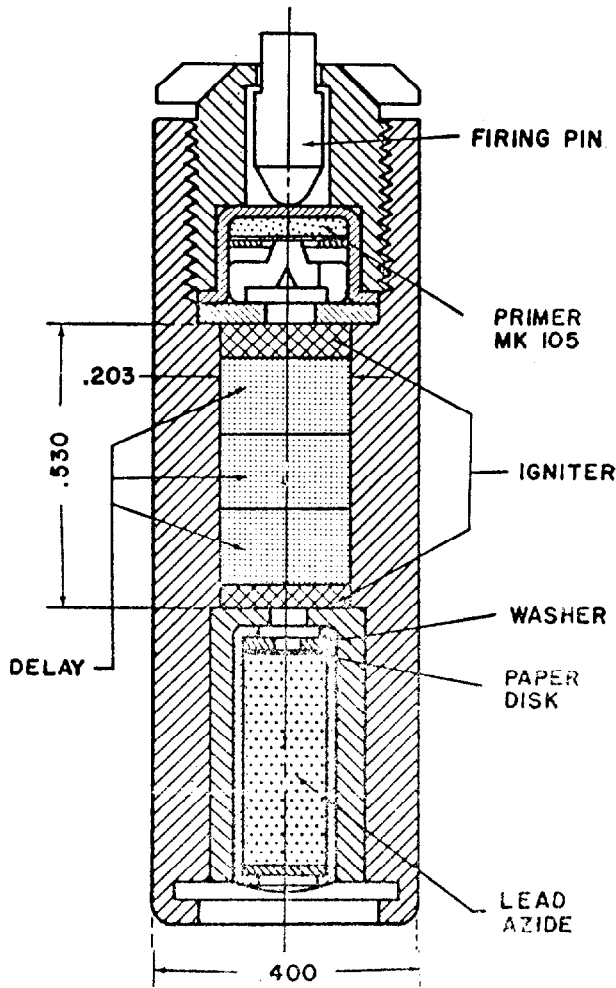

Fig 1-56. OBTURATED GASLESS DELAY ELEMENT FOR 4 TO 6 SECONDS PERCUSSION DETONATOR

non-obturated delay may be ignited by a BkPdr flash, as from an ejection charge; the seal on the obturated delay prevents such initiation, and it must be ignited by an electric or percussion primer which, in turn, is actuated by electrical or mechanical energy. The obturated delay element assembly possesses the advantage that it may be more readily sealed against adverse atmospheric influence.

Following are some "Obturated Gasless Delay Element Assemblies"; described in Ref 23, pp 5-50 to 5-61 and in other sources.

Obturated Gasless Delay Element for Percussion Detonator with 4 to 6 second de-

lay, is shown in Fig 5-41 taken from Ref 23, p 5-52 (Our Fig 1-56). Its primer charge is the same as in Mk105 Primer (MF 31.25, K chlorate 37.50 & Sb sulfide 31.25%) (Ref 23, p 3-11) base charge LA. Composition of igniter charge can be, accdg to Ref 23, p 55, either Si 40.0, Pb dioxide 30.0 & Cu oxide 30% (Igniter Mixture "6-6-8") or Zr 25 & BA chromate 75% (Igniter Mixture Z3); compn of delay charge can be either: Ba chromate 70.0, Ni 17.0, K perchlorate 7.5 & Zr 5% (Delay Mixture HP-25) or Mixture D-5 which consists of Mn, Ba chromate & Pb chromate in variable proportions according to delay time desired.

In Fig 5-44 of Ref 23 (See our Fig 1-57) is shown a delay element which is assembled within a single housing as an integral part of Flame Initiated 0.10 Second Flash Delay Detonator. Its igniter mixture is probably M31 (Pb sulfocyanate 45 & K chlorate 55%) (Ref 23, p 2-10); the delay compn is either HP-25 or D-5; the intermediate charge is LA and the base charge is RDX.

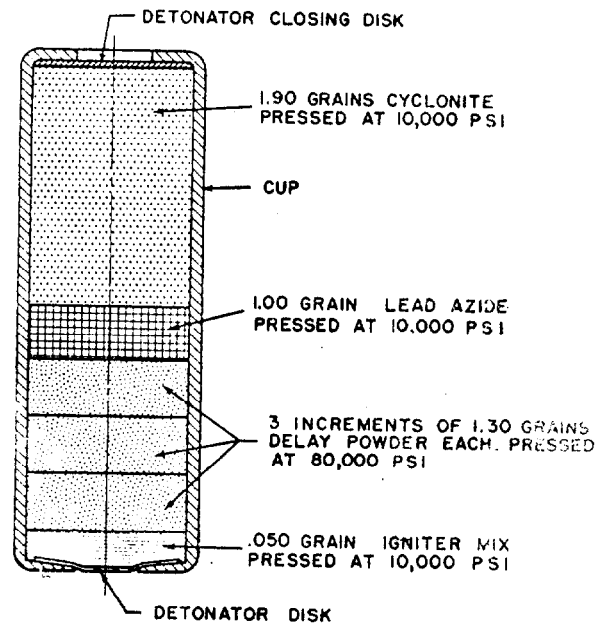
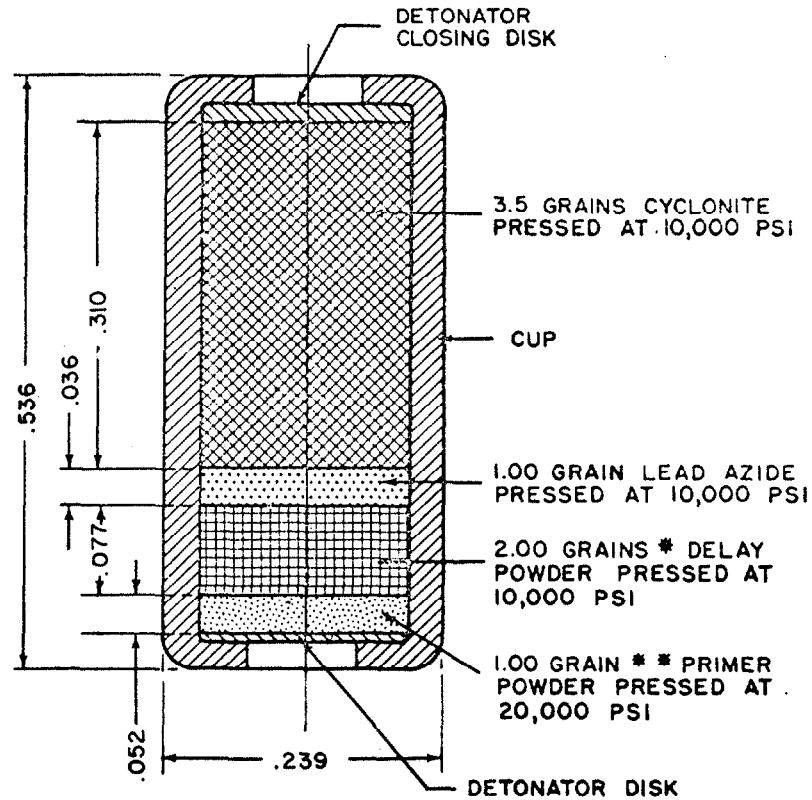

Fig 1-57. FLAME INITIATED 0.10 SECOND FLASH DELAY DETONATOR



* DELAY POWDER CONSISTS OF
ZIRCONIUM 55 %
BARIUM CHROMATE 45 %

** PRIMER POWDER CONSISTS OF
NORMAL LEAD STYPHNATE 15 %
BASIC LEAD STYPHNATE 10 %
TETRACENE 5 %
ANTIMONY SULFIDE 15 %
ALUMINUM 10 %
BARIUM NITRATE 45 %

Fig 1-58 STAB-INITIATED 0.02 SECOND
DELAY DETONATOR

Another delay element is shown in Fig 5-45 of Ref 23 (See our Fig 1-58). It is assembled within a single housing as an integral part of Stab Initiated 0.02 Second Delay Detonator. Compositions of primer, igniter, delay, intermediate and base charges are listed in our Fig 1-58. The detonators shown in Figs 1-57 and 1-58 were developed under Army auspices and investigated at Picatinny Arsenal [See PATR 1657 (1947)] (Ref 23, pp 5-59 & 5-60)

'Navy Electric Delay Fuze Detonator Mk35 Mod 1' described in Ref 23, p 5-51 and shown here in Fig 1-59 is more powerful than Navy Delay Fuze Primer Mk1 15, due to the addition of 0.75 g PETN to the base chge. Otherwise, its construction is similar to Mk115 Fuze Primer, described in Ref 23, p 5-50 and also in this Section under "Delay Fuze Primers" (See Fig 1-62)

SI-98 Squibs are employed for initiation of columns in delay detonators. The SI-98

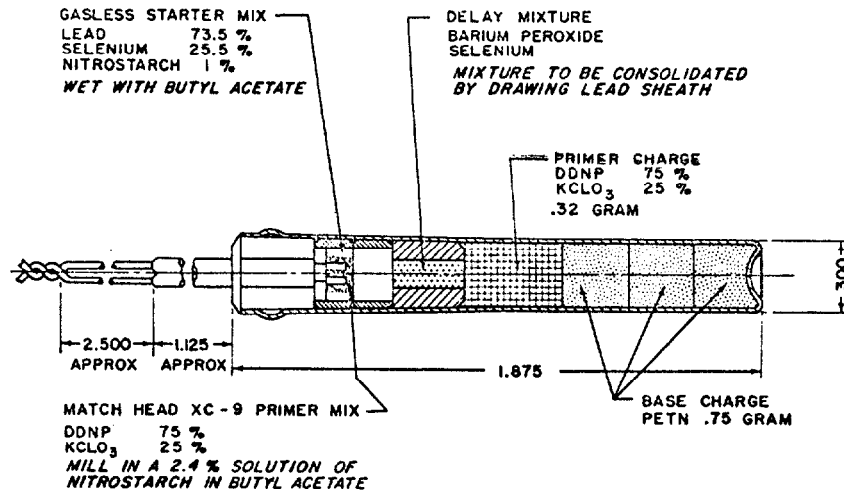
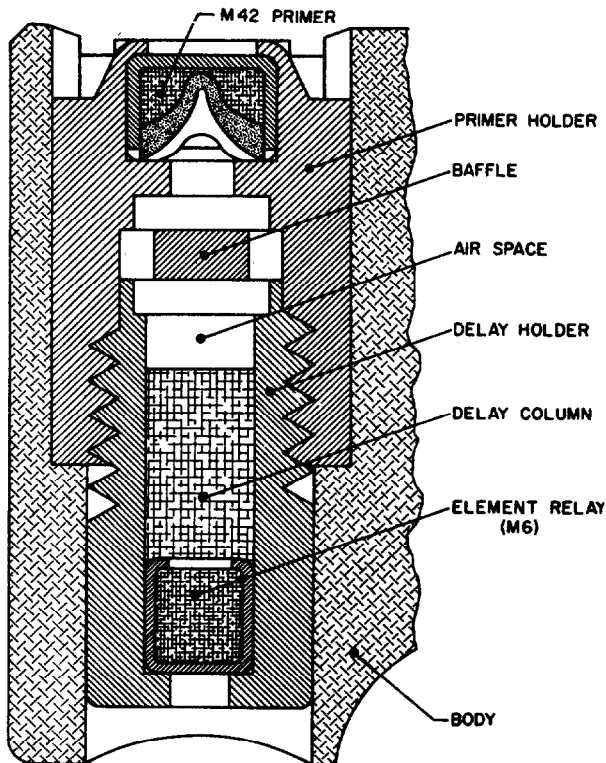

Fig 1-59 ELECTRIC DELAY DETONATOR
 Mk35Mod1



Composition, loaded in M112 Fuze, consists of MoO₃ 26, KClO₄ 21 & Zr 53% and is usually pressed at 36000 psi

Another example of obturated gasless delay element is the one used in pyrotechnic items and shown in Ref 54, p 5-32) (See Fig 1-60)

Following is the list of gasless delay compositions given in Ref 54, p 5-34, Table 5-13 and p 5-35, Table 5-14

Fig 1-60 OBTURATED GASLESS DELAY ELEMENT

Table

| Fuel, % | Oxidants, % | Inert, % |
|----------------------|--|------------------------------|
| Mn 30-45 | BaCrO ₄ 0-40 & PbCrO ₄ 26-55 | None |
| B 4-11 | BaCrO ₄ 89-96 | None |
| B 13-15 | BaCrO ₄ 40-44 & Cr ₂ O ₃ 41-46 | None |
| Ni/Zr Alloy 26 | BaCrO ₄ 60 & KClO ₄ 14 | None |
| Ni 5, Zr 31 (Mix) | BaCrO ₄ 22 & KClO ₄ 42 | None |
| Ni 7, Zr 17 (Mix) | BaCrO ₄ 70 & KClO ₄ 8 | None |
| W 27-39 | BaCrO ₄ 59-46 & KClO ₄ 9.6 | Diatomaceous Earth 3-12 |
| W 39-87 | BaCrO ₄ 46-5 & KClO ₄ 4.8 | Diatomaceous Earth 3-10 |
| W 20-50 | BaCrO ₄ 70-40 & KClO ₄ 10 | None |
| Mo 20-30 | BaCrO ₄ 70-60 & KClO ₄ 10 | None |
| Si 20 | Red Lead (Pb ₃ O ₄) 80 | Celite 3 to 7 parts added |
| Zr 28 | PbO ₂ 72 | None |
| Se 16 | BaO ₂ 86 | Talc 0.5 added |

In Table 5-20, p 5-40 of Ref 54 are given compositions of *ignition powders for gasless delay elements*

Table

| Fuel, % | Oxidants, % | Inert, % |
|------------------|-----------------------------------|--------------------------|
| Zr 65 | Fe ₂ O ₃ 25 | Diatomaceous Earth 10 |
| B 10 | BaCrO ₄ 90 | None |
| Zr 33 & Ti 17 | Fe ₂ O ₃ 50 | None |
| Zr 51 | Fe ₂ O ₃ 39 | Diatomaceous Earth 10 |
| B 30 | PbO ₂ 70 | None |

In Table 5-29, p 5-49 of Ref 54 are given some *first fire, starter and igniter compositions*

Delay trains used in pyrotechnics are described in Section 4, Part F

Following is an example of *Non-Obtured (Vented) Gasless Delay Assemblies*. It is described in Ref 23, pp 5-53 & 5-54 and shown here in Fig 1-61

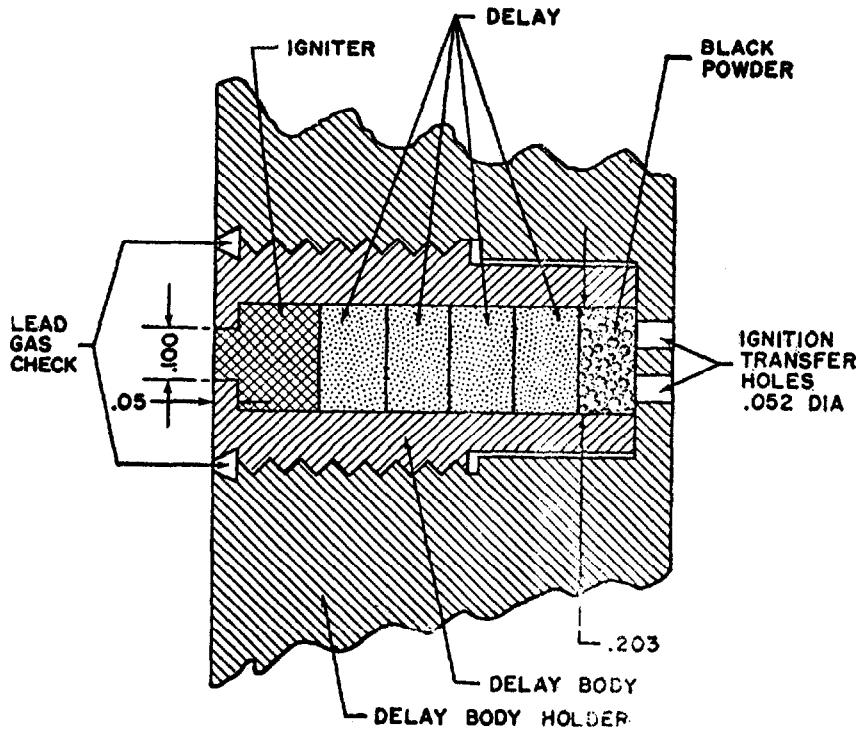

Fig 1-61 TYPICAL 4-5 SECOND NON-OBTURATED GASLESS DELAY ELEMENT

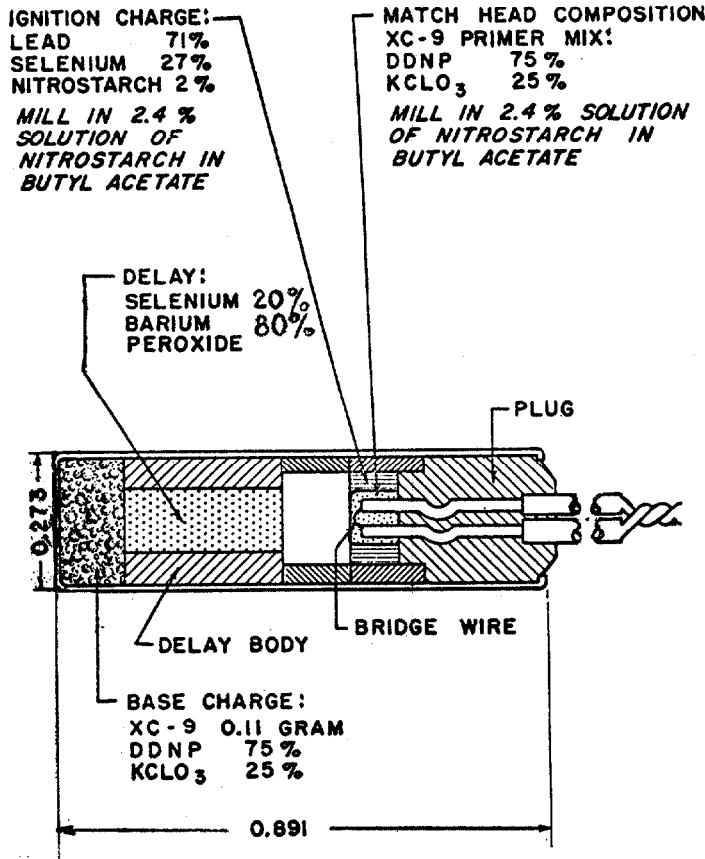

Fig 1-62 GASLESS ELECTRIC FUZE PRIMER Mk115

A "Typical 4-5 Second Non-Obtured Delay Element" was designed to provide a delay between two BkPdr expulsion chges in an illuminating projectile. The 1st BkPdr chge initiates the igniter in the 0.1 inch diam opening and when the delay has burned, the BkPdr in the delay cavity flashes thru the ignition transfer holes to ignite the 2nd expulsion chge. The compn of igniter chge is not stated but it probably is either "Igniter F33B" [Zr 41.0, Fe₂O₃ 49.0 & "Superfloss" (SiO₂) 10.0%] or "Igniter 6-6-8" (Si 40.0, PbO₂ 30.0 & CuO 30.0%) listed in Ref 23, p 5-55. The compn of gasless delay is probably either "Delay HP-25" (Ba chromate 70.5, Ni 17.0, K perchlorate 7.5 & Zr 5.0%) or "Delay D-5" (Pb chromate, Ba chromate & Mn in variable proportions) (Ref 23, p 5-55)

Section 4, Part F

d) Gasless Delay Fuze Primers

There is no strict division between "delay primers" and "delay detonators" and some items listed in NOLTR 1111 (Ref 23) as "delay primers" can be considered as detonators

For example, "Electric Delay Fuze Primer Mk115"; listed in Ref 23, p 5-50 and shown here as Fig 1-62, contains, among other ingredients, a base charge and there is no reason (in our opinion) why it should not be called detonator.

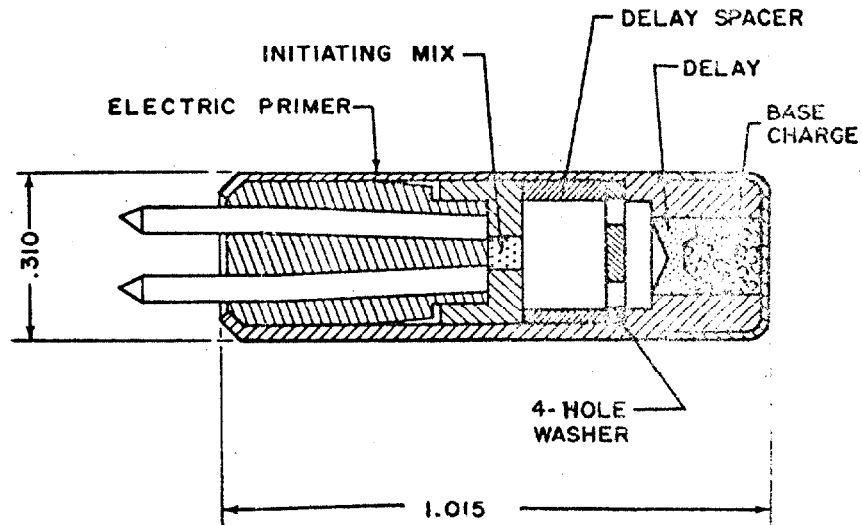

Fig 1-63 EXPERIMENTAL DELAY PRIMER

The Mk115 primer, shown in Fig 5-39 has a burning time of 0.25 second and has been employed in the Navy Fuze ND-59. Other primers used in the same fuze are Mk116 & Mk117. They are similar in construction to Mk1 15, except that their delay columns are longer. Their delay times are 0.50 & 1.0 sec, respectively. In these primers the match-head compn (XC-9 Primer Mix) surrounding the bridge wire is covered with an ignition chge. This chge, which produces a hot flame with very little brisance, is designed to ignite the delay column without causing disruption which might lead to erratic burning times. The delay mixture is loaded into a Pb sheath and consolidated by drawing the loaded sheath down to a specific diameter

Another item listed in Ref 23, p 5-58 as primer is "Experimental Electric Delay Primer". It is shown in Fig 5-43 of Ref 23 and on our Fig 1-63. Here the delay case is made of stainless steel and is crimped over a bridge wire type electric initiator. The initiating chge consists of 5 mg of normal LSt (Lead Styphnate) packed around the bridge wire. The delay train is interposed between the flash and base charges. A delay spacer 0.155 inch long, followed by a 4-hole delay washer and a further space of 0.050 inch between the washer and the surface of the delay, prevents the explosion of the LSt from disrupting the delay pellet. Initiation of the delay is aided by a cone-shaped depression in the face of the pressed delay next to the initiating chge. The "step" in the line of demarcation between the delay and the base chge aids in ignition transfer as well as in the loading procedure

Section 4, Part F

e) Relays and Relay Detonators

The term "relay" is defined at the beginning of this Section. To this definition may be added the following description of a *relay detonator*, which is taken from Ref 23, pp 5-30 to 5-33 and slightly reworded and abbreviated:

After expiration of the delay time, a substantial spurt of flame is needed to initiate the main detonator of the fuze, demolition device, or other Ordnance item. Since the

delay column is purposely kept small in diam to reduce the volume of gas evolved, it may become necessary to include a separate chge known as *relay*. This condition exists particularly with vented delay elements, since the pressure retained at the terminal end of the time train is greatly reduced. An initiator explosive (such as LA loaded in an Al cup, while formerly MF was used), is usually employed in a relay because it does not introduce any appreciable delay and it takes flame readily. The relay chge, which is fastened securely to the delay by a crimp or thread, finds its greatest usefulness in designs where air gaps exist or are likely to exist between the terminal end of the delay and the receiving explosive chge. In cases where variable air gap conditions do not exist or when the air gap is very small with high confinement, the "relay detonator" is omitted and the "main detonator" is secured close to the terminal end of the delay

In Fig 5-27 taken from Ref 23, p 5-31 (See our Fig 1-64), is shown a relay detonator which has given satisfactory results in 7 and 7.7-sec vented delay elements in the temperature range of -65°F to 160°F. The lightly pressed BkPdr chge at the terminal end of the vented delay column is provided to produce sufficient heat and pressure to assure reliable initiation of the LA chge. A thin paper disk should be provided to prevent contact between BkPdr and Al container for LA

No relays for use in fuzes are described in NOLR 1111 (Ref 23), but Odierno (Ref 45d, p X A) lists nine types of relays, M1 to M7 and XM10 & XM11, comprising Al cups loaded for all, except XM10, with 32 to 100 mg of dextrinated LA. The XM10 Relay contains 65 mg RD1333 (Brit exptl LA, See Vol 1 of Encycl, p A558-R) as lower chge and 25 mg LA as upper chge. The housing of these relays consists of Al cups 0.123 to 0.213 inch diam and 0.095 to 0.245 inch long

Section 4, Part F

f) Leads (Used in Explosive Trains)

The term "lead", a device used in fuzes,

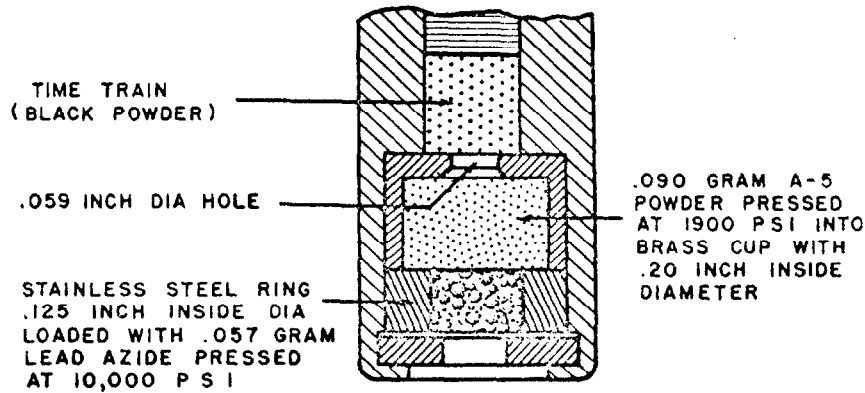

Fig 1-64 RELAY DETONATOR

is defined at the beginning of this Section. There may be one or more leads to complete the path of the firing train between the detonator and booster. If the lead following the detonator is located in the same fuze part as the detonator, it is called *lead-out* and if it is located in the same part as the booster it is called *lead-in* (See our Fig 1-65, which is found as Fig 6-1 on p 6-1 of Ref 23). Here the firing train is shown in the armed position. When in unarmed position, the detonator holder is rotated 90° from the position shown

When there is more than one lead as in Fig 6-1, each successive lead should be of a larger diameter so that the intensity or

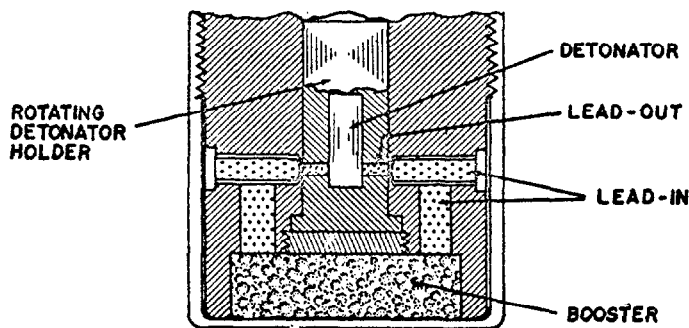

Fig 1-65 LOCATION OF LEAD-IN AND LEAD-OUT IN THE FIRING TRAIN. ARMED POSITION

the effective energy of the detonation wave continues to build up as the wave follows the constricted explosive channel to the booster. If the diameter of the leads is gradually increased, the difference between the size of the last lead and the booster is not great and will result in greater assurance of initiating the booster chge (Ref 23, p 6-3)

In some cases there is only one "lead" and it is located in a place of its own. Such an item is known as "lead" without a suffix in or out (See Fig 6-2 of Ref 23) (Our Fig 1-66)

Accdgd to Ref 23, pp 6-5 to 6-8), the leads can be either "cup-type" or "non-cup-type". The cup may be pre-flanged as shown in Fig 1-67 and then loaded with HE chge before being inserted in the fuze bulkhead where it is crimped in place, as shown in Fig 1-68. The seal betw the detonator chamber and the booster cavity thus depends on the crimp. The above design has been used by the Army, but the Navy preferred to insert the empty non-flanged cup in the bulkhead, then flange the cup, as shown in our Fig 1-69, and press the expl chge in place. No crimping is required since the sides of cup expand during pressing of expl chge, thus securing a tight fit in the bulkhead lead hole. The flange serves to secure the lead in the fore direction (Ref 23, pp 5-5 to 5-6)

The diameter of cup varies from 0.093 to 0.200 inch and thickness of their bottom

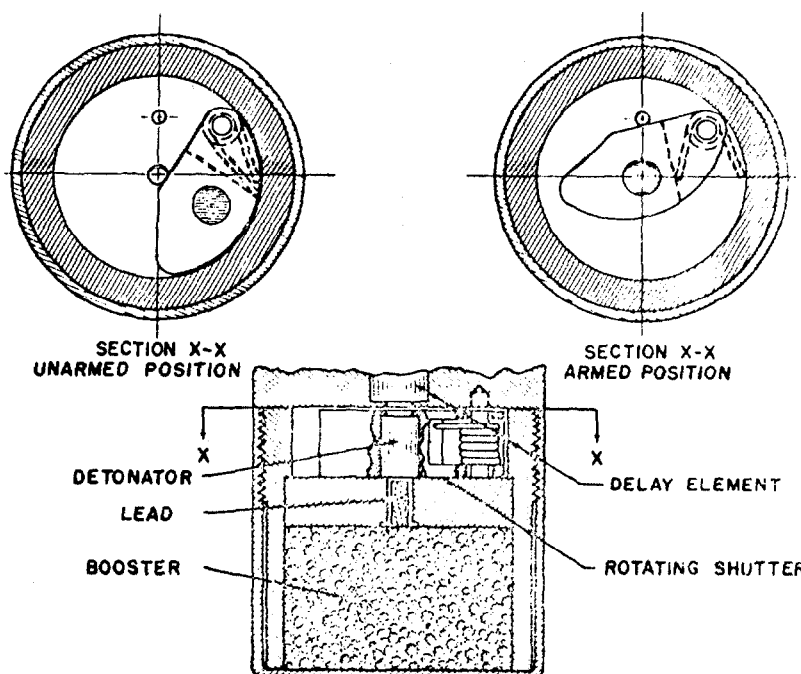

Fig 1-66 LOCATION OF A LEAD IN A FIRING TRAIN

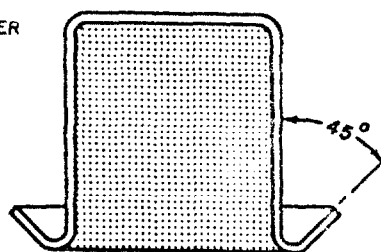

Fig 1-67 ARMY PRE-FLANGED LEAD CUP

from 0.005 to 0.0016 inch (Ref 23, p 6-5)

The *non-cup type lead*, also known as *open-type lead*, is, accdg to Ref 23, p 6-7, often used where the fuze parts and the leads are so small (such as 0.075 inch diam) that it would be impractical to use a cup. Here the lead chge is pressed directly into the fuze bulkhead hole and the exposed surface of the chge is sealed by a lacquer or varnish followed by thorough drying. In designs where safety devices slide or rotate above the lead chge, the hole should be loaded ca 0.005 inch below the surface to permit space for the sealing material (See Fig 1-70a, reproduced from p 6-7 of Ref 23)

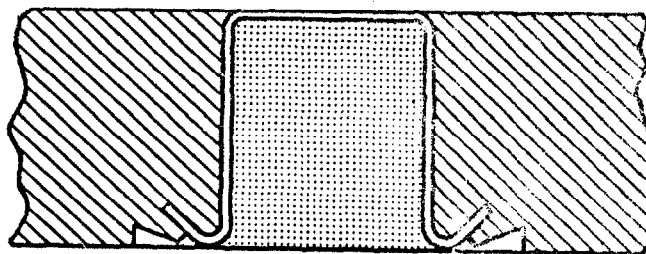

Fig 1-68 ARMY LEAD CUP INSERTED IN FUZE BULKHEAD

Where high shock conditions are likely to be encountered, some provision must be made to further secure the lead in place by supplementing the side wall friction obtd during consolidation. Scoring of the wall of the lead hole (See Fig 1-70b) is the usual practice. It can be accomplished by tapping the hole and then passing a drill thru to remove the crests of the threads, unless very fine threads are used. This smoothes the roughness of

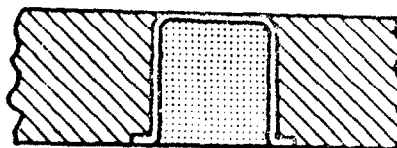

Fig 1-69 NAVY LEAD CUP PLACED IN FUZE BULKHEAD AND THEN FLANGED

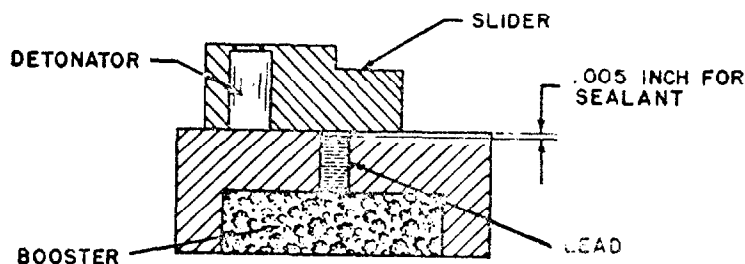

Fig 1-70a NON-CUP TYPE OR OPEN-TYPE LEAD



Fig 1-70b SCORING THE WALL OF THE LEAD HOLE

scoring, thus reducing the possibility of loss in chge density by binding in the scores or grooves. For this type of lead, loading pressures 15000 to 20000 psi are usually employed (Ref 23, pp 6-7 to 6-8)

Accdg to NOLR 1111 (Ref 23, p 6-3), Tetryl has been almost universally used as an expl chge in leads, but Pentolite and some other expls were tried but not found superior to Tetryl. Accdg to later information as given by Odierno (Ref 45d, p XI A), all new design booster leads contain RDX because it is considered to be more effective than Tetryl. Nevertheless, the majority of Army booster leads listed in Ref 45d, pp XI B to XI F (16 out of 19) contain Tetryl and only 3 contain RDX. All these Army leads are of the "open-end flange type". Most of the cups (15 out of 19) are of gilding-metal, varying in sizes from 0.135 to 0.197 inch for outside diameter; 0.123 to 0.180 for inside diameter; 0.162 to 0.560 for length; and 0.005 to 0.010 inch thickness of bottom. They are loaded with 70 to 363 mg Tetryl at a pressure of 10000 psi. The two newer type leads contg RDX are loaded in Al cups and one in stainless steel. The dimensions of Al cups are: No 7 - OD 0.169 inch, ID 0.157, length 0.278, thick-

ness of bottom 0.0070 and chge 140 mg RDX pressed at 10000 psi; No 13 - OD 0.169, ID 0.158, length 0.175, thickness of bottom 0.005 and chge 99 mg RDX pressed at 10000 psi. The stainless steel cup (No 17) has: OD 0.169, ID 0.157, length 0.177 and thickness of bottom 0.177 and chge 68.5 mg RDX pressed at 10000 psi. One Al cup (No 2) contains a chge of Tetryl pressed at 10000 psi

Section 4, Part F

g) Delay Trains Used in Pyrotechnics

According to Ellern (Ref 57, p 197), BkPdr was the only mixture used in pyrotechnic delay columns until ca 1929. As these mixts evolved much gas and since this could produce high pressure in the items where confinement (obturation) is desirable, a search for low-gassing or gasless delay mixts was undertaken at PicArns by G.C. Hale. His compn developed in 1929 contd silicon, red lead (Pb_3O_4) or lead chromate with some glycerine serving as a binder. These mixts were gas-forming to some extent but the mixts of Ba peroxide and chalcogens patented by Dr Jean Picard in 1934 (USP 1971502) were truly low-gassing mixts. WWII provided a new impetus to research and development, and many "gasless" delay mixts were developed since then

Four pyrotechnic delay compositions given in 1961 edition of Ellern (Ref 44a) are listed in Vol 3 of Encycl, p D50. In regard to "Exotic" Delay Mixtures, Dr Ellern remarks in the 1968 ed of his book (Ref 57, p 415), that these formulations were actually prep'd and tested in his laboratory, but the limited investigation was not further pursued by him or by others. At the time of development of Nb(Cb)-Ta - Ba Chromate mixts, the delay mixts with Cr, Mo & W (Tungsten) were classified in US. That is why Dr Ellern developed his own mixts which were not classified, although their components Niobium and Tantalum were rather expensive

Numerous delay mixtures, which were not listed in 1961 edition are described in 1968 ed, as Formulas 185 to 195 incl, pp 383-86. We have combined them in Table I

**Table I
Pyrotechnic Delays**

| Components | Formulas | | | | | | | | | | | | | | | | | | | | |
|--|----------|-----|-----|-----------------|-----------------|-----------------|-----------------|-----------------|-----------------|-----------------|-----------------|-----------------|-----------------|-----------------|-----------------|-----------------|-----------------|-----------------|-----------------|-----------------|-----------------|
| | 185 | 186 | 187 | 188 <u>a</u> | 188 <u>b</u> | 188 <u>c</u> | 188 <u>d</u> | 188 <u>e</u> | 188 <u>f</u> | 189 <u>a</u> | 189 <u>b</u> | 189 <u>c</u> | 189 <u>d</u> | 190 <u>a</u> | 190 <u>b</u> | 190 <u>c</u> | 190 <u>d</u> | 190 <u>e</u> | 190 <u>f</u> | 190 <u>g</u> | 190 <u>h</u> |
| Ba Chromate | | 95 | 90 | 31 | 31 | 31 | 60 | 60 | 60 | 3 | 14 | 20 | 31 | 58 | 56 | 52 | 52 | 41 | 22 | 12 | 32 |
| Ba Peroxide | | | | | | | | | | | | | | | | | | | | | |
| Boron(amorphous) | | 5 | 10 | | | | | | | | | | | | | | | | | | |
| Chromium | | | | | | | | | | | | | | | | | | | | | |
| K perchlorate | | | | 15 | 15 | 15 | 14 | 14 | 14 | | | | | 10 | 9 | 10 | 9 | 5 | 5 | 5 | 5 |
| Lead(Red) (Pb ₃ O ₄) | 80 | | | | | | | | | | | | | | | | | | | | |
| Lead Chromate | | | | | | | | | | 53 | 47 | 43 | 36 | | | | | | | | |
| Manganese | | | | | | | | | | 44 | 39 | 37 | 33 | | | | | | | | |
| Molybdenum | | | | | | | | | | | | | | | | | | | | | |
| Selenium | | | | | | | | | | | | | | | | | | | | | |
| Silicon | 20 | | | | | | | | | | | | | | | | | | | | |
| Superfloss | | | | | | | | | | | | | | 5 | 5 | 5 | 5 | 5 | 10 | 3 | 5 |
| Tellurium | | | | | | | | | | | | | | | | | | | | | |
| Tungsten | | | | | | | | | | | | | | 27 | 30 | 33 | 34 | 49 | 63 | 80 | 58 |
| 70/30-Zr/Ni | | | | 54 | | | 26 | 9 | 3 | | | | | | | | | | | | |
| 50/50-Zr/Ni | | | | | 54 | | | | | | | | | | | | | | | | |
| 30/70-Zr/Ni | | | | | | 54 | | 17 | 23 | | | | | | | | | | | | |
| Burning Time (sec/in) | | 2.5 | 0.5 | 2.5 | 5 | 8 | 2 | 5 | 12 | 3.7 | 5.8 | 8.7 | 13.5 | 40 | 32 | 29 | 18 | 10 | 3.5 | 1.5 | 1.0 |

(CONTINUED)

(CONTINUATION)

| Components | Formulas | | | | | | | | | | | | |
|--|-----------------|-----------------|-----------------|-----------------|-----------------|-----------------|-----------------|-----------------|-----------------|-----------------|-----------------|-----------------|-----------------|
| | 191 <u>a</u> | 191 <u>b</u> | 191 <u>c</u> | 191 <u>d</u> | 191 <u>e</u> | 192 <u>a</u> | 192 <u>b</u> | 192 <u>c</u> | 192 <u>d</u> | 192 <u>e</u> | 193 <u> </u> | 194 <u> </u> | 195 <u> </u> |
| Ba Chromate | 10 | 20 | 25 | 25 | 50 | | 10 | 40 | 55 | 65 | | | |
| Ba Peroxide | | | | | | | | | | | 80- 84 | 40 | 70 |
| Boron(amorphous) | | | | | | | | | | | | | |
| Chromium | 80 | 70 | 62 | 50 | 40 | | | | | | | | |
| K perchlorate | 10 | 10 | 13 | 25 | 10 | 20- 11 | 10 | 5 | 10 | 5 | | | |
| Lead(Red) (Pb ₃ O ₄) | | | | | | | | | | | | | |
| Lead Chromate | | | | | | | | | | | | | |
| Manganese | | | | | | | | | | | | | |
| Molybdenum | | | | | | 80- 89 | 80 | 55 | 35 | 30 | | | |
| Selenium | | | | | | | | | | | 20- 16 | 20 | |
| Silicon | | | | | | | | | | | | | |
| Superfloss | | | | | | | | | | | | | |
| Tellurium | | | | | | | | | | | | 40 | 30 |
| Tungsten | | | | | | | | | | | | | |
| 70/30-Zr/Ni | | | | | | | | | | | | | |
| 50/50-Zr/Ni | | | | | | | | | | | | | |
| 30/70-Zr/Ni | | | | | | | | | | | | | |
| <u>Burning Time</u> (sec/in) | 1.5 | 2.5 | 3.8 | 7.0 | 7.7 | 0.01- 0.04 | 0.1 | 2 | 6 | 18 | 3.6- 4.0 | 9.0 | 4.4 |

Remarks to Table I:

Formula 185 designated as "Delay Mixture V", can be mixed with 8-10% acetic soln of Celluloid (NC/Camphor) - 1.8 parts (dry basis) per 100 pts of Formula 185. To these may be added 3-7 pts of diatomaceous earth for adjustment of BT

Formulas 186 & 187, designated as "Boron Type Delays", are used in "photoflash cartridge fuzes" for 1 & 2-sec delays. Formula 187 can function at reduced pressure

Formulas 188_{a-f}, designated as "Zr/Ni Alloy Type Delays", contain Zr/Ni alloys treated with Na dichromate, accdg to USP 2696429 (1954) by D. Hart, to promote stability in delay time after prolonged storage of finished items

Formulas 189_{a-d}, designated "D-16 Manganese Type Delays", was formerly prep'd by a tedious procedure described in USP 2832704 (1958) by R.H. Comyn. However, his more recent investigation "Stability of Manganese Delay Mixtures", Rept AD 268079 (1961) & CA 61, 526 (1964) has shown that tedious procedure is actually undesirable

Formulas 190_{a-h}, designated as "Slow Burning Delays with Tungsten", are gasless delays of which formula 190_a is probably the only reliably functioning pdr with BT as long as 40 sec/in in unobturated state. BT's may vary widely with particle size and manufg procedure of the metal pdr and only certain grades (selected by trial & error) will produce reliably burning columns

Formulas 191_{a-e}, designated "Delays Based on Chromium", are described by D.E. Olander, USP 3028229 (1962) & CA 57, 1096-97 (1961). Accdg to Ellern they "seem not to have received the attention they deserve"

Formulas 192_{a-e}, designated as "Delays Based on Molybdenum", were described in the above patent of Olander.

They extend from BT 0.01 to 18 sec/in. When in loose form some of them burn very violently

Formulas 193, 194 & 195, designated as "Delays for Detonators", are described by D.T. Zebree in USP 3113519 (1963). They are used in combinations with Pb/Se and Pb/Te ignition mixts, which are not listed in Ellern's books 1961 & 1968 edns

In Table J, which is a slightly modified version of Ellern's Table 14 (p 208), are listed burning time and burning rates of fuses, ignitacords and delay columns used in pyrotechnics

Remarks to Table J:

Description of Safety Fuse, Ignitacord, Quickmatch and Pyrofuze is given elsewhere in the text

Compositions of various delay mixts are given in Table I

Formulas 192 & 193 are "very fast"; Formulas 186, 187, 188_d, 190_{g&h}, 191_{a&b} and 192 as "fast". Formulas 188_{b&e}, 189_{a&b}, 190_f, 191_{c,d,&e} 192_d and 193 as "intermediate"; Formulas 188_{c&f}, 189_{c&d}, 190_{d&e} 192_e and 194 as "slow"; and Formulas 190_{a,b&c} as "very slow"

Some additional information on delay items is given below

Safety Fuse, described in Spec MIL-F-20412, is used for delaying action in the "Aircraft Smoke and Illuminating Signal AN-Mk 5 Mod 1" (Drift Signal), where ignition is effected on impact on the water and a 9-sec delay gives time for submersion and resurfacing prior to smoke and flame emission (Ref 57, p 207)

Safety fuse for "Float Light" AN-Mk 6 Mod 2 is of a much longer delay time (90-sec), because this signal is initiated at the moment of release from an aircraft (Ref 57, p 207). The device is similar to AN-M6-Mod 3 described in "Military Pyrotechnics", TM 9-1370-200 (1966), p 4-13

On p 209, Ellern gives a brief description of use of safety fuse in selective fuzes for the Mk 5, 6 & 10 parachute flares and in the fuze for the Mk 24. He also discusses me-

Table J
Burning Times and Burning Rates of
Fuse Trains

| Type | sec/in | sec/ft | sec/yd | sec/cm | in/sec | cm/sec |
|---------------|--------|--------|--------|--------|--------|--------|
| Safety Fuse | 3.33 | 40 | 120 | 1.3 | 0.3 | 0.8 |
| " " | 2.5 | 30 | 90 | 1.0 | 0.4 | 1.0 |
| Ignitacord: | | | | | | |
| Type A, Green | 0.75 | 9 | 27 | 0.3 | 1.33 | 3.4 |
| Type B, Red | 1.5 | 18 | 54 | 0.6 | 0.67 | 1.7 |
| Quickmatch | | | 8 & 17 | | | |
| Quarrycord | | | ca 3 | | ca 12 | |
| Pyrofuze | | | 2.4- | | ca 12 | |
| | | | 5.4 | | | |
| Delay Column: | | | | | | |
| Very fast | 0.1 | 1.2 | | 0.04 | 10 | 25.4 |
| Fast | 1.0 | 12 | | 0.4 | 1 | 2.5 |
| Intermediate | 5.0 | 60 | | 2.0 | 0.2 | 0.5 |
| Slow | 10.0 | 120 | | 3.9 | 0.1 | 0.25 |
| Very slow | 30.0 | 360 | | 11.8 | 0.03 | 0.085 |

thods for fabricating delay columns

On p 210 is mentioned USP 2103014 (1937) by M. Palmieri & S.D. Ehrlich, in which an electrically ignited heat source transmits its heat to a metallic rod or cup that on reaching a certain temperature sets off a heat sensitive charge

Some "nonpyrotechnic long delays" are discussed on pp 210-12 of Ref 57

Section 4, Part G

Boosters

To the description of boosters given in Vol 2 of Encycl (Ref 44), pp B243 to B246, there are added here a few drawings of boosters which were not listed. These drawings, Figs 71a, 71b & 71c are taken from Ref 23, pp 7-4, 7-6, 7-7 and 7-8:

Booster Assembly for BD (Base Detonating) Fuze Mk21 is an example of a Navy booster used for AP (armor-piercing) projectiles. It is combined with "lead-in" charge and is considered to be easy to load (Fig 1-71a)

Booster Assembly for BD Fuze M60 is an example of non-cylindrical boosters, the need for which is brought about by individual weight, space, or other requirement that ne-

cessitates a more complex shape. This booster, having an increasing cross section in the direction outward from the initiating lead, functions more efficiently in that it produces the maximum development of the wave front in the booster material which results in greater surety of initiating the main charge. This type of booster will produce a directional wave along the axis of the charge,

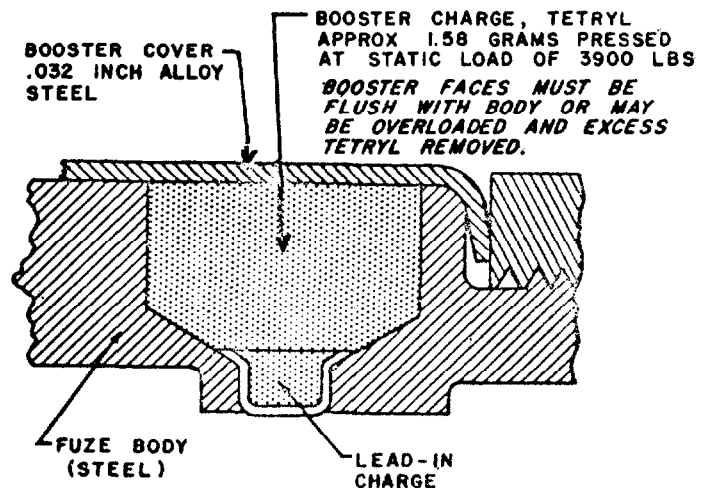

Fig 1-71a BOOSTER ASSEMBLY FOR BD FUZE, Mk21

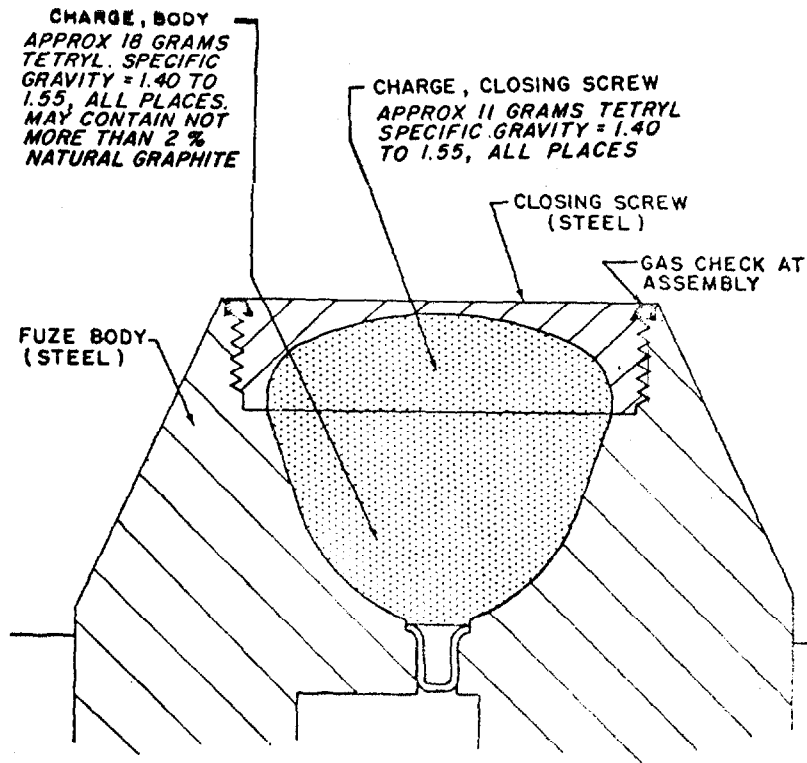

Fig 1-71b BOOSTER ASSEMBLY FOR BD FUZE, M60

especially when relatively strong side confinement is used. This characteristic of directional output is utilized in fuze applications, especially for AP projs, which often cannot accommodate large cylindrical boosters because of the difficulty of mounting such charges. Disadvantage of non-cylindrical boosters is in difficulty of loading. The charge is pressed in two parts - one into the body cavity, the other into the closing screw. The booster is used in 6 & 8-inch AP projs (See Fig 1-71b)

Booster Assembly for Auxiliary Detonating Fuze, Mk 44, is an example of booster mounting employed for items not subject to large impact forces. The assembly is intended for use with impact fuzes for SQ (superquick) functioning and with time fuzes for flight functioning. It has been successfully used in projectiles ranging from 3 to 6 inches (Fig 1-71c)

Booster Assembly for Bomb Fuze, AN-M103A1, is an example of the booster and the seat liner assembly of a conventional fuze for GP (general purpose) bombs. The pelleted Tetryl charge is mounted within a steel sleeve that is encased by a steel cup. The pellets are supported at the proper height by pressed felt discs such that, in assembled position, the charge is isolated from the booster case. The type of fuze used with this booster is normally fitted into a fuze seat liner of 0.031 inch steel incorporated into the bomb. The mounting is not considered sufficiently strong to withstand severe target impacts and remain functional. The surety of functioning is enhanced by the fact that this booster is imbedded within its burster charge (Fig 1-71d)

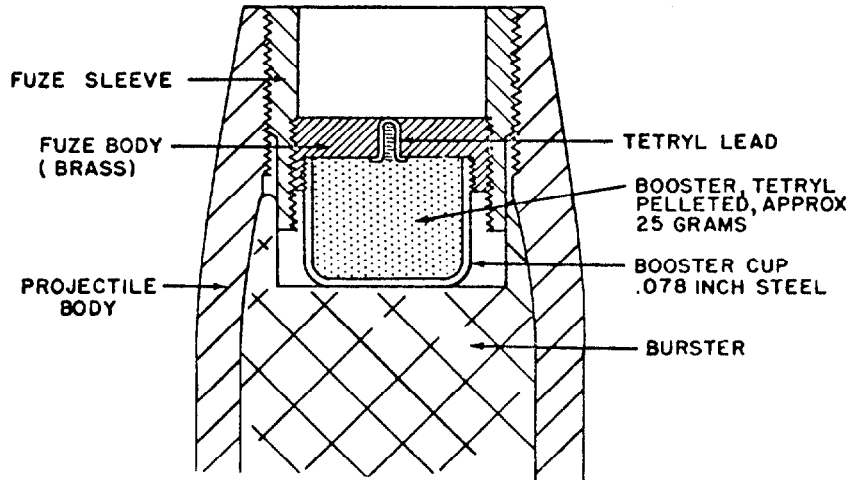

Fig 1-71c BOOSTER ASSEMBLY FOR AUXILIARY
DETONATING FUZE, Mk44

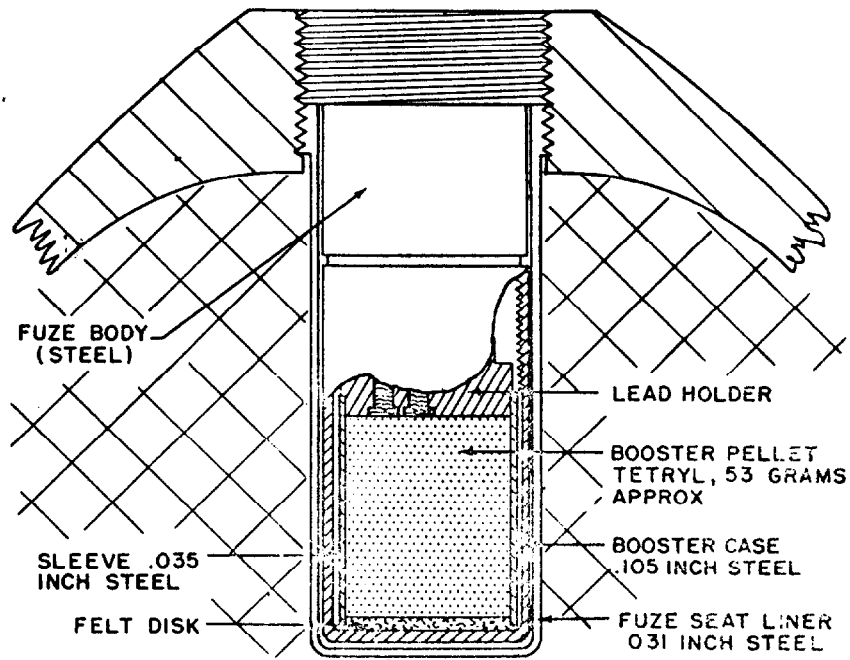

Fig 1-71d BOOSTER ASSEMBLY FOR BOMB FUZE,
AN-M103A1

Section 5 FUZES Introduction

A *fuze* is a complicated mechanical device, metallic or plastic, housing combustible and/or explosive components in a row known as "train". It is designed to initiate an item of ammunition on being subjected to one of the following actions: stab, percussion, friction, mechanical time, chemical, electrical or hydrostatic pressure

Fuzes may be subdivided into *igniting* and *detonating*, depending on how they initiate items of ammunition. Fuzes *igniting* contain in their housing "ignition trains" (See Section 3, Part B). They are used to initiate, by ignition, items containing low explosives, such as some pyrotechnic devices, chemical warfare ammunition and some land mines. Fuzes *detonating* contain in their housing the "explosive trains" (See Section 4, Part C of this work). They are used to initiate, by detonation, items of ammunition containing high-explosives. These items may include artillery shells, airplane bombs, guided missiles, rocket warheads and some demolition devices

There is also a *nonexplosive fuze* which is designed to initiate an explosion in an item of ammunition by an action such as continuous or pulsating electromagnetic waves, acceleration, and/or deceleration forces, changes in atmospheric pressure and/or temperature, chemical impact, or piezoelectric action. Excludes switch (as modified). (Ref 38b, p 125; Ref 40a, p 75 and Notice 1 to Ref 40a)

Before proceeding to describe typical fuzes, there are listed in alphabetical order various fuzes. The following references were used as sources of information: Ohart (Ref 17, pp 125-26), Glossary of Ordn (Ref 38b, pp 125-29) and MIL-STD-444 (Ref 40a, pp 75-82)

Section 5, Part A List of Fuzes

Fuze, Airburst. See *Fuze, Barometric*

Fuze, Air Nose. A point detonating (PD) rocket fuze which uses the air stream to arm itself

Fuze, Air Pressure. See *Fuze, Barometric* and *Fuze, Concussion*

Fuze, All Way or Fuze, Always. An impact fuze designed to function regardless of the direction of target impact

Fuze, Antidisturbance or Fuze, Antihandling. A fuze designed to become armed either after impact, or after being emplaced, so that any further movement or disturbance will result in detonation

Fuze, Antiwithdrawal. A fuze incorporating a device intended to initiate detonation of an item of ammunition if attempt is made to remove the fuze from the item

Fuze, Arming. A fuze is said to be "armed" when it is ready to function. Arming corresponds to "cocking" in a small arm (Ref 17, p 127)

Fuze, Auxiliary Detonating (ADF). An additional fuze used to augment the output of a fuze explosive train or to increase the overall safety features of an item of ammunition (Compare with "Activator" described in Section 2, Part A of this work, "Glossary of Ordnance and Other Terms Used in This Description of Ordnance Items")

Fuze, Bare. An unprotected and unpackaged fuze separated from its intended piece of ammo

Fuze, Barometric or Air-Pressure. A fuze that functions as a result of change in pressure exerted by the surrounding air. Usually the change in pressure occurs by reason of travel from a region of one ambient pressure to a region of different ambient pressure

Fuze, Base (BF). Any fuze installed in the base of a projectile (Compare with *Fuze, Tail*)

Fuze, Base Detonating (BDF). A fuze located in the base of a projectile, designed to be activated as result of impact

NOTE: All References are listed in Section 7, pp D1023 to D1055

Fuze, Base Detonating, Self-Destroying (BDF-SD). A BDF contg a device which causes the projectile bursting chge to detonate if prior functioning has not been caused by impact

Fuze Body. The part of a fuze which houses the majority of the functioning parts, and to which small parts are attached. It also houses elements of an "ignition train" or of an "explosive train" (See Section 4, Part C, Item b)

Fuze, Bomb. A fuze for use in bombs to be dropped from aircraft

Fuze, Bomb, Inert. A bomb fuze without expl components used for training purposes

Fuze, Bore Riding. A fuze which incorporates as a safety device a "bore riding pin". This pin is held in place while the projectile or missile is within a gun barrel or launching tube and then ejected from the fuze by centrifugal effects or spring action beyond the muzzle

Fuze, Bore Safe. A fuze that has a means of preventing the detonator from initiating an expln of the bursting chge while the projectile is in the bore of a gun, or the missile is within its launching tube (See also Fuze, Safety)

Fuze, Bullet Impact. A fuze designed to set off a demolition charge by the impact of a bullet. Eg: Fuze, Bullet Impact M1 - for projected charge demolition kit M2A1 and M3

Fuze and Burster Bomb. A combination of fuze and burster, for use in a bomb, such as a liquid-filled incendiary bomb, which may be filled in the field

Fuze Cavity or Fuze Well. A socket or hole in a bomb, projectile or missile for housing a fuze or its portion

Fuze, Cavity Liner. A thin-walled lining in the fuze cavity of a bursting charge (Ref 38b, pp 126 & 173)

Fuze Chronograph. Proving ground instrument for measuring accurately the time of flight of a projectile provided with a time fuze from the gun or launcher to the point of air burst. The instrument uses a photoelectric impulse tube which is pointed towards the expected point of burst. The light from the burst is picked up by the photoelectric cell and serves to stop the operation of recording instrument which had been started by the passage of the previously magnetized projectile through a coil mounted on the muzzle of a weapon (Ref 38b, p 126). The instrument may be used with any of several recording or time measuring systems, which are described under Chronograph in Ref 38b, pp 70-71 or in Vol 3 of Encycl (Ref 48, pp C306 to C310)

Fuze, Combination (CF). A fuze combining two different types of fuze mechanisms, such as impact and time mechanisms (See Fuze, Time and Superquick)

Fuze, Command. A fuze that functions as a result of intelligence transmitted to it from a remote location by means not directly associated with its environment

Fuze, Concrete Piercing. A fuze especially designed for piercing concrete before detonating its projectile

Fuze, Concussion or Airburst. A bomb fuze designed to function in the air in response to the concussion produced by the explosion of a preceding bomb (Compare with Fuze, Airpressure and Fuze, Barometric)

Fuze, Contact. A fuze wherein primary initiation results from actual contact with the target to include such phenomena as impact, crush, tilt or electrical contact (See also Fuze, Impact)

Fuze, Delay or Delay Action. Any impact fuze incorporating a means of delaying its action after contact with the target. Delay fuzes are classified according to the length of time of delays. There are Fuze, Long Delay; Fuze, Medium Delay and Fuze, Short

Delay (Delays are described in Vol 3 of Encycl, p D50 and in Section 4 of this work)

Fuze, Detonating. A fuze designed to initiate the main explosive charge of an item of ammunition by a detonating action of "explosive train" (See Section 3 of this work), as compared to the igniting action of a "fuze igniting", contg "ignition train" (See Section 3 of this work)

Fuze, Dummy. An imitation of a fuze having the same shape, weight and center of gravity as loaded fuze but contg no explosives or moving parts. Used in training

Fuze, Electric or Electronic. A fuze which depends for its arming and functioning upon events of an electronic nature. Such a fuze does not necessarily have to be entirely electric and may contain mechanical components (Compare with Fuze, Mechanical)

Fuze, Electric Time. A fuze in which the time from initiation of action to the functioning can be controlled by "setting" and is determined by electronic events

Fuze, Electromechanical. See under Fuze, Mechanical

Fuze, Explosive Train. See Explosive Train in Section 3 of this work

Fuze, Flare. A fuze, such as MT (mechanical time), to initiate ignition of the charge in a flare, which is a pyrotechnic item designed to produce a single source of intense light for purposes such as target and/or airfield illumination

Fuze, Flashback. See Fuze, Spitback

Fuze, Friction. A fuze initiated by pulling a toothed wire or plug thru friction-sensitive expl mixture in a fuze primer

Fuze, Guided Missile. A fuze (such as Nose T1402 or Proximity, Sidewinder M303Mod0) to initiate functioning of explosive charge in a guided missile at the desired time

Fuze, Hand Grenade. A pyrotechnic delay fuze initiated by release of a lever which in turn permits a striker to impinge on a primer. The output of the fuze is designed to ignite or detonate a filler of a hand grenade

Fuze, Hydrostatic. A fuze employed with depth bombs or charges to cause underwater detonation at a predetermined depth. Initiation is caused by increasing ambient water pressure

Fuze, Igniting. A fuze designed to initiate a main charge of munition by an igniting action, as compared to the detonating action of the "fuze, detonating". This type of fuze is suitable only for munitions (such as pyrotechnic items) using a main chge of LE (low explosive) or other readily ignitable material

Fuze, Ignition Train. See Ignition Train in Section 3 of this work

Fuze, Impact. A fuze designed to be initiated by the force of impact (Compare with Fuze, Contact; Fuze, Friction; Fuze Percussion; and Fuze, Stab)

Fuze, Inert. A regular fuze but contg no explosive, pyrotechnic or chemical agent. Used in training

Fuze, Inertia. See Fuze, Nondelay

Fuze, Influence. See Fuze, Proximity or VT (Variable Time)

Fuze, Instantaneous (IF). See Fuze, Superquick (SQF)

Fuze, Kit Bomb. A group of inert bomb fuzes used for training purposes

Fuze, Land Mine. See under Fuze, Mine

Fuze, Live. A fuze contg explosive, pyrotechnic or chemical agent

Fuze, Long Delay. A delay fuze for use in bombs, in which the fuze action is delayed for a relatively long period of time, from minutes to days (Ref 40a, p 78). Ohart (Ref 17, p 126) gives delay time 0.5 to 70 sec

Fuze, Mechanical (MF). A fuze which depends for its arming and functioning on events primarily of a mechanical nature. Fuzes combining mechanical and electronic features are known as *electromechanical fuzes (EMF)*. Some mechanical fuzes are functioned by electrical energy from a piezoelectric element. Some *proximity fuzes* contain a mechanical delayed arming device

Fuze, Mechanical Time (MTF). A fuze which is actuated by a clocklike mechanism "preset" to the desired time (Excludes Fuze, Bomb; Fuze, Mine; and Fuze, Hand Grenade)

Fuze, Mechanical Time, Dummy. An imitation of an MTF having the same shape, weight and center of gravity as loaded fuze, but without expl components or moving parts. Used for training

Fuze, Mechanical Time, Inert. An MTF without explosive, pyrotechnic or chemical components

Fuze, Mechanical Time and Superquick (MTSQF). An MTF contg an additional device designed to cause instantaneous activation as a result of impact (Excludes Fuze, Bomb; Fuze, Mine; and Fuze, Hand Grenade)

Fuze, Medium Delay. A type of delay fuze, especially for bombs, in which the fuze action is delayed for a period of time between that of short delay and long delay fuzes, normally 4 to 15 seconds

Fuze, Mine. A fuze designed to initiate a train of fire in a *land mine*. For initiation of *underwater (sea) mine* a device known as "Firing Mechanism, Underwater Mine". It is a device contg combustible or explosive components, which can be actuated by an acoustic signal, impact, hydrostatic pressure, and/or magnetic influence (Ref 40a, pp 71 & 79)

Fuze, Nondelay (NDF) or Fuze, Inertia.

A fuze that functions as a result of inertia of firing pin (or primer) as missile is retarded during penetration of a target. The inertia causes the firing pin to strike the primer, initiating fuze action. This type of fuze is slower in action than the instantaneous or superquick fuze, since its action depends upon deceleration (retardation) of the missile during impact with the target

Fuze, Nose. A fuze located in the forward end of a bomb, and some missiles, but this term is not applied to fuzes located in the forward end of an artillery projectile (See Fuze, Point)

Fuze, Percussion. A fuze actuated by a sharp blow of a firing pin with a dull end on a primer, without breaking thru wall of primer cup (See Section 3 of this work)

Fuze, Point (PF). A fuze for use in the forward end of an artillery projectile or rocket warhead

Fuze, Point Detonating (PDF). A fuze located in the forward end (point) of a projectile and designed to be actuated by impact. There are also Dummy and Inert Point Detonating Fuzes

Fuze, Point Detonating, Self-Destroying (PDFSD). A PD fuze contg a device which causes the bursting chge to detonate if prior functioning has not been caused by impact (Excludes Fuze, Bomb; Fuze, Mine; and Fuze, Hand Grenade) (See also Fuze, Self-Destroying)

Fuze, Point Detonating, Training.

An item simulating PDF for use in training. It is provided with manual safety and/or setting devices simulating those of a standard or proposed standard PDF. It may or may not be a ballistic match with the fuze it is supposed to represent and/or contains a small expl chge for realism or spotting purposes (Excludes Fuze, Point Detonating, Dummy)

Fuze, Point Initiating (PIF). A fuze which has the target sensing element in the nose of a missile (Usually refers to PIBDF's) (See next item)

Fuze, Point Initiating Base Detonating (PIBDF). A fuze with initiating components located in the forward end of projectile, while detonating components are located in the base of projectile. It is designed to be activated by impact

Fuze, Proximity; Fuze, VT (Variable Time); Fuze, Radio; or Fuze, Influence. A fuze wherein primary initiation occurs by sensing the presence, distance, and/or direction of the target thru the characteristics of the target itself or its environment

Fuze, Radio or Fuze, Radio Proximity. See Fuze, Proximity

Fuze, Range. Range at which projectile will burst when the fuze is set at a given time value in order to produce burst at a predetermined point in space (Ref 38b, p 128)

Fuze, Rocket. A fuze for initiating a rocket warhead. Some rockets, such as the 12.75-inch Rocket are initiated by firing mechanisms, such as Mk15Mod0

Fuze, Safe Arming Distance. The minimum from the launcher of a rocket which is safe for personnel and material at the time of warhead bursting

Fuze, Safety. Two terms have been commonly used to describe the safety built into a fuze to prevent premature functioning at the time of using, and to provide the required safety in transportation

The first term, "bore safety", is applicable only to fuzes used in cannon and mortar projectiles or in rockets. It refers to the provision of means to prevent functioning while in the bore of the artillery weapon or in the rocket-launching tube. Such fuzes are said to be *bore safe*. A fuze which is not provided with a safety device to prevent the explosion of the main charge of an ammuni-

tion item prematurely, while it is still in the bore of the weapon, is known as *nonbore safe*

The second term "detonator safety" may be applied to any fuze provided with a detonator. It refers to the provision of means to prevent functioning of the succeeding element(s) of the explosive train if the detonator starts to function prematurely, while the fuze parts are still in the safe position. Such a fuze is said to be *detonator safe* (Ref 40a, pp 82 & 105)

Fuze, Sea (or Underwater) Mine. See under Fuze, Mine

Fuze, Secondary. See Activator in Glossary of this work (Section 2)

Fuze, Selective Delay. A delay fuze which permits a selection from two or more functioning delay times

Fuze, Self Destroying. A fuze designed to destroy itself and the associated munition after flight to a range greater than intended. Employed in AA ammunition, to avoid impact in friendly territory

Fuze, Service. A fuze intended for US combat ammunition, rather than for training purposes

Fuze, Service. A fuze standardized for use in British Armed Forces

Fuze Setter. A device designed for manual and/or automatic setting of time fuzes (Ref 38b, p 128)

Fuze Setter-Rammer. An automatic electrically motivated mechanism combining fuze setter and rammer. It is utilized to feed single rounds of ammunition, set the fuzes, and ram the rounds into the chamber of antiaircraft guns. It automatically sets fuzes according to electrical fuze data transmitted from a remote control director to the motor drive, which, in conjunction with an amplifier, converts the electrical data to mechanical data in the transmission assem-

bly. When operating automatically, all that is required of the operators is the selection of the type of round, the loading and the firing (Ref 38b, p 128)

Fuze, Short Delay. A type of delay fuze used both in bombs and artillery projectiles, in which the fuze action is delayed for a short period of time, less than 1 second (Ref 40a, p 80). Ohart (Ref 17, p 126) gives for short delay fuze the time of delay betw 0.05 and 0.25 sec

Fuze, Smoke Pot. An igniting type fuze designed to start combustion in a smoke pot. Eg: Fuze, Smoke Pot, Igniting M207A1 (for Floating Smoke Pot M4A2)

Fuze, Spitback or Fuze, Flashback. A fuze located in the forward part of a shaped charge munition. When initiated by impact it produces a detonation which is directed toward the element located in the base of munition and this, in turn, detonates the main explosive charge. The combination of point impact fuze and base element is referred to as "point initiating base detonating" (PIBD) fuzing system

Fuze, Standard. Any fuze standardized for use in US Armed Services

Fuze, Standard Contour. A point fuze having a standard shape, size and shape agreed upon for use with a certain group of artillery projectiles. Such fuzes may be interchanged without affecting the flight of the projectile

Fuze, Superquick (SQF). A PD fuze designed to function with the least possible delay (of the order of microseconds) after impact

Fuze, Supersensitive. A PD fuze which is designed to function dependably and instantly at the slightest touch with a very light target such as fabric of an airplane wing. Its construction is similar to SQ fuze, except that the firing pin in the nose is free floating when armed (Ref 17, p 126 and Ref 38b, p 128)

Fuze, Tail. A fuze inserted in the after end of a bomb (Compare with Fuze, Base)

Fuze, Time (TF). A fuze that can be preset to function after the lapse of a specified time

Fuze, Time and Superquick (TSQF). A fuze which is activated by the burning of a powder train (ring or column) preset to the desired time and which contains an additional device designed to cause instantaneous activation as a result of impact (Excludes Fuze, Bomb; Fuze, Mine; and Fuze, Hand Grenade)

Fuze, Torpedo. A fuze designed to initiate functioning of the warhead of a torpedo. Eg: Fuze, Torpedo Mk142Mod0

Fuze, Underwater Mine. See under Fuze, Mine

Fuze, Variable Time. See Fuze, Proximity

Fuze, VT. See Fuze, Proximity

Fuze Well. See Fuze Cavity

Note: In designation of Army fuzes and other items of ammunition, the letter M followed by an arabic number signifies Model (Eg: M1, M2, etc). Letter A which follows an arabic number signifies Modification of the original model. For example, M1A1 signifies 1st modification of Model 1 and M1A2 its 2nd modification. A suffix B indicates an item of alternate (substitute) design, material, or manuf. The items standardized by both Army & Navy have AN preceding M. Letter T or letters XM and an arabic number signify development items and their modifications are indicated by letter E, followed by arabic number

In designation of Navy items letters MK signify Mark and they are followed by arabic numbers; modifications are indicated by Mod (Eg: MK2Mod1)

In designation of Air Force items a more complicated system, which is hard to explain, is used. For example, BLU-10/B signifies a complete round for the 250 fire bomb

Section 5, Part B Fuzes, Igniting

These devices are activated by ignition and not by detonation as in ordinary fuzes. There are only a few igniting fuzes known and they are not used in HE artillery projectiles.

Following is one example of igniting fuzes: *Fuze, Igniting, M74*. Although this fuze is known as "point detonating" it is not detonating, but "igniting". It has been used to ignite the BkPdr spotting charge of the practice cartridge M92 in 37-mm subcaliber guns. It does not have or require a booster. The fuze (See Fig 1-72) consists of a Zn-alloy body recessed at the forward end to hold a direct-action firing pin and recessed again at about the middle of the fuze to hold a rotor housing and rotor assembly. The base is closed by



Fig 1-72 FUZE, IGNITING
M74

a Zn-alloy-plug which screws into the body serving both to close the base of the fuze and to hold the rotor housing assembly firmly in position in its recess. The rotor housing is drilled thru, at right angles to the vertical axis of the fuze, to provide a recess for the rotor. The rotor is a cylindrical steel assembly slotted and weighted with two Pb plugs at one end and drilled in two places: one, to hold the detonator; the other to provide a recess for a U-shaped setback pin. In the un-

armed or interrupted position, the rotor holds the detonator diagonally across the vertical fuze axis and away from the firing pin, thus providing safety in handling and during firing. The rotor is locked in the unarmed position by the setback pin.

Functioning. Upon firing the round, setback causes the setback pin to move rearward into its recess. After the friction due to setback is overcome, the rotor is free to turn under the action of centrifugal force, thereby bringing the detonator in line with the firing pin. This pin remains in a floating position until impact, whereupon it is driven rearward into the detonator. The flash from the detonator ignites the BkPdr charge of the shell.

As was already mentioned, igniting fuzes are not used in artillery projectiles loaded with HE's; only fuzes activated by detonation are used.

Section 5, Part C Artillery Fuzes

a) Definitions

According to Ohart (Ref 17, pp 125-26), artillery fuzes may be classified:

- a) According to assembled position in the projectile: such as *base detonating fuze (BDF)* - assembled in the rear end of projectile and *point detonating fuze (PDF)* - assembled in the forward end of projectile
 - b) According to time of functioning: *impact fuze (IF)* - functions immediately on impact with target; *time fuze (TF)* - functions in the air at expiration of a predetermined time; and *combination fuze (CF)* - a combination of impact and time fuze, or of two actions at impact
 - c) According to specific action at functioning: *superquick fuze (SQF)* - a PDF of fastest action possible; *non delay fuze (NDF)* - a PDF or BDF acting with retardation of only few milliseconds; *supersensitive fuze (SSF)* - a PDF which acts at the slightest touch; used in AA guns; *short delay fuze (SDF)* - a PDF or BDF with a delay element 0.05 to 0.25 sec inserted in explosive train; *long delay fuze (LDF)* also called *time fuze (TF)* - a PDF with a delay element of 0.5 to 70 sec
- There are also: *electric fuze (EF)*, *time*

and *superquick fuze* (TSQF) and some other fuzes which are briefly described in the "List of Fuzes" given in Part A of this Section 5

In TM9-1300-203 published in 1967 (Ref 52, pp 5-1 to 5-3), the fuzes intended to explode projectiles consist of a connected series (train) of small explosive charges and a mechanical or electrical device (or combination of both) for initiating the first charge in the train. The initiating device and explosive elements are held in a body (housing) of fuze. In the case of *point-detonating* (PD) fuzes, the part of the fuze body protruding from the forward part of the projectile is shaped for best ballistic effect. In *impact fuzes*, the explosive train usually consists of small but highly sensitive explosive charge of *primer mixture* followed by a larger and less sensitive expl chge such as LA, in turn followed by a still less sensitive expl chge such as Tetryl. Such chges function by successive detonations - hence the term, *detonating fuze*. A fuze designed for delay action contains a compressed BkPdr pellet (*delay element*), which, being placed after primer is ignited by its flash. BkPdr has been used exclusively in the time-train of powder-train time fuzes, and for the magazine charge of both powder-train and mechanical types of time fuzes. BkPdr compressed to great density burns slowly, the rate of combustion decreasing as the density increases

Current artillery fuzes may be classified accdg to their position in the projectile as *base-detonating* (BD), *point-initiating base, detonating* (PIBD), *point detonating* (PD) and *concrete-piercing* (CP). BD fuzes are used with some types of armor-piercing (AP) and a few types of high-explosive (HE) projectiles. PIBD fuzes are generally used with high-explosive antitank (HEAT) projectiles

Fuzes may be classified accdg to their method of function into impact, time, proximity and a combination of these. Impact fuzes can be *superquick* (SQ), delay and non-delay. A time (airburst) fuze functions while the projectile is still in flight. There are three types of such fuzes: mechanical-time (MT), powder-train time and proximity. Powder-train time fuzes differ from mechanical-time fuzes es-

entially in that the former uses a compressed BkPdr train to delay functioning, whereas the mechanical-time fuze uses a clockwork mechanism to achieve delay. Some time fuzes are also provided with an impact element. Proximity fuzes are radioactuated point fuzes which can function, either after a preset arming time, or without setting or adjustment, on approach to a target

Fuzes contain safety devices that tend to prevent functioning until after the fuze has been subjected to centrifugal and setback forces, after the round is fired. In the so-called *bore-safe* fuzes, the path of the explosive train is interrupted so that, while the projectile is still in the bore of the weapon, premature expln is prevented should any of the more sensitive fuze elements (such as primer and/or detonator) start to function. Interruption is usually achieved by inserting out-of-line components or interrupter blocks or slides. Although this leaves the fuze in an *unarmed* position, it would not be considered safe in handling or shipping, unless the fuze was not provided with safety devices such as safety wires or cotter pins. These outside devices must be removed prior to inserting the fuzed round of ammunition into gun barrel, but the fuze will still be unarmed because some of its inside parts are not free to move to their proper positions so that the fuze may operate in its intended manner

Arming of fuzes can be accomplished by centrifugal force and/or inertia (setback). Upon firing a proplnt chge in a gun, the projectile starts to move with acceleration and rotation. Acceleration will cause setback, while rotation will produce centrifugal force. Both forces will act upon movable safety parts inside the fuze and if it is a time fuze, the setback force alone will be sufficient for arming. If the fuze is impact-type, a combination of setback and centrifugal force will be required to achieve the same purpose. As the projectile leaves the muzzle of the weapon, the acceleration (and hence setback) ceases, while rotation (and hence centrifugal force) continue to act, although at gradually reduced speed. Fuzes using centrifugal force for arming must be so designed that they will not be unarmed as the rotational velocity

decreases during flight. Some fuzes may be provided with "delay arming devices" to prevent complete arming until the fuzed projectile will be some distance from the weapon. Arming of proximity fuzes can be delayed by a series of safety devices. The fuze becomes automatically armed a specified length of time after projectile is fired

The inertia created by "set-forward force" (See Section 2, Glossary), which is caused either by deceleration in flight or on impact may be utilized in fuzes to drive firing pins into primers or to drive primers against stationary firing pins

Following is description of various artillery fuzes:

Section 5, Part C

b) Point Detonating (PD) Artillery Fuzes, Including Time (T), Superquick (SQ) and Time Superquick (TSQ) Fuzes

These fuzes, located in the forward parts of projectiles, are described in the 1967 edi-

tion of TM9-1300-203 (Ref 52, pp 5-12 to 5-53). Fuzes used during WWII are described in Ref 17, pp 143-53; and in Ref 20a, pp 272-78, 282-91, 297-300, 305-08, 312-14, 316-22 & 324-25

Fuze, PDM8 is an Army SQ impact fuze used with 4.2-inch chemical cartridges. The complete assembly consists of the fuze proper with an Al body, its various components, and a seamless steel burster tube. The bursting charge consists of ca 65 g of Teteryl pellets in the burster tube and lead cup. The fuze is described in Ref 52k pp 5-12 to 5-15, but a Fig is not given (Also Ref 20a, pp 272-78)

Fuze, PDM9 is an Army SQ impact fuze which is used with 4.2-inch HE cartridge M3. It is identical with fuze M9 except that it has a booster instead of a burster tube. The function of the Teteryl booster in fuze M9 is to transmit the shock action to TNT filler in

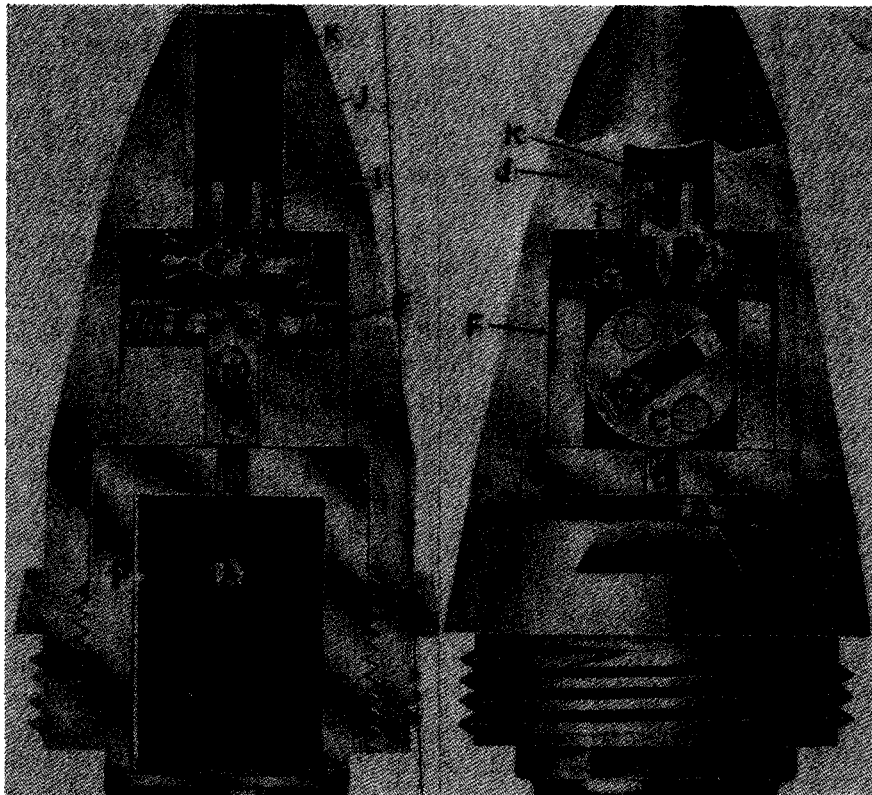

Fig 1-73 FUZE, PD, SQ Mk 27

projectile. The fuze is described in Ref 52, p 5-15, but a Fig is not given (See also Ref 20a, p 278)

Fuze, PDMk27, originally a Navy fuze, has been standardized for Army procurement to be used with 40-mm HE ammunition. It is a single-action SQ type constructed to function on light impact. The fuze (See Fig 1-73) is made up of two major parts: 1) A body (J) recessed to hold the firing pin (I) with its striker (K) and a rotor assembly (F) holding a disk-shaped rotor (C); and 2) A base plug (P) which holds the booster lead (B) and the booster charge (A) of Tetryl. The base plug also serves to seat the rotor assembly (F) securely in its recess when the fuze is assembled. The rotor is seated in its assembly so that it can revolve only on an axis perpendicular to the major axis of the fuze, and normally holds the detonator (D) out of alignment with both the booster (A) and the firing pin (I). Two centrifugally actuated plunger pins (E) under spring tension lock the rotor in the unarmed position until a prescribed minimum centrifugal force has been established. A bushing (H) in the forward end of the rotor assembly recess forms a guide for the firing pin (I). A peg-like striker (K) is secured to the forward end of pin (I), providing for increased sensitivity on impact. The pin (I) is supported by two spring-held plunger pins (G) until sufficient centrifugal force has been established after firing to overcome the resistance of plunger springs

Functioning. No action takes place on firing until a prescribed centrifugal force has been set up by rotation of the projectile in its travel, whereupon the plunger pins (G) holding the rotor assembly (F) and those supporting the fire pin (I) move forward. Upon release from its detents, the rotor (C) revolves, bringing the detonator (D) into alignment with the firing pin (I) and the booster lead (B). Upon the outward movement of its plunger pins, the firing pin has an unobstructed passage to the detonator, but remains at the forward end of the fuze until impact, due to creep action. On impact

the striker (K) rebounds from the impact, which is transmitted thru the thin front section of the nose and forces the striker against the detonator (D). Impulse of (D) is transmitted thru lead (B) to booster (A) and then to bursting charge of the projectile (Ref 20a, pp 324-25 & 328; Ref 17, pp 149-50; and Ref 52, pp 5-51 to 5-53)

Fuze M43. See under Mechanical Time Fuzes

Fuzes, PD M48A3 and M48A2 are selective SQ-delay types. Either action can be obtained, prior to firing, by turning a setting sleeve in the side of the fuze. These fuzes are similar in construction and action to Fuzes M51A5 and M51A4 (see next item), except that Fuzes M48 series do not include a booster (Ref 52, p 5-15; Ref 17, pp 152-53 & Ref 20a, pp 282-83)

Fuzes, PD M51A5 and M51A4 are selective SQ-delay types, both similar in construction and functioning, with the exception of the delay plunger firing pin. The M51A5 fuze (See Fig 1-74) consists of a head (A) which holds the superquick element (B), a body (H) which holds a delay plunger assembly in its housing (M) and a selective setting device (JLK). These main assemblies are connected by a flash tube (G) which holds and supports the parts firmly in position, and are supported further by a thin-walled ogive (F). The superquick element is comprised of firing pin (D) supported by a cup-shaped gilding metal firing pin support (C) and detonator (E). The firing pin support is strong enough to withstand initial setback forces upon firing, but collapses under impact at the target. The delay plunger assembly (M) is an inertia plunger type and includes a firing pin (N), primer (P), BkPdr delay pellet (Q), and a relay charge (T). The selective setting device consists of an eccentrically positioned plunger (K), called interrupter and spring (L), the functioning of which is regulated by a setting sleeve (J). The head of the sleeve is slotted to facilitate turning when selecting the setting. For exact alignment, two register lines and the markings "SQ"

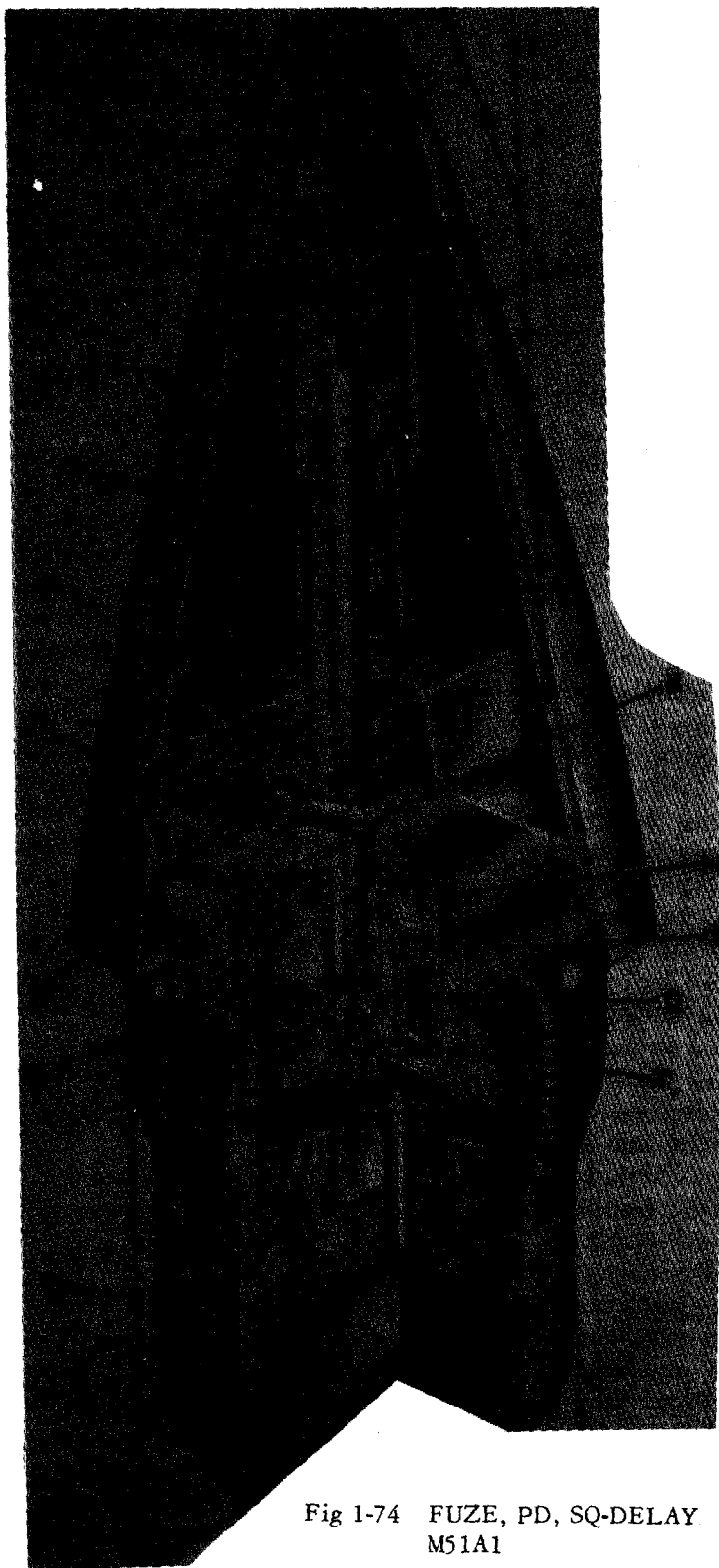

Fig 1-74 FUZE, PD, SQ-DELAY
M51A1

and "DELAY" are stamped on the ogive (F). When the slot in the sleeve head is aligned with the "SQ" line (parallel to the fuze axis), or 15° thereto, the setting sleeve, which is thicker on one side than on the other, is turned so that it does not interfere with the movement of interrupter (K). The (K) is free therefore to move outward under centrifugal force, and thereby open the passage for SQ action. When the slot is aligned with the "DELAY" line (at right angle to the fuze axis) or within 15° thereto, a section on the setting sleeve (J) rests against (K), securing it in the lower extremity of the recess, across the SQ passage. Bore-safe SQ action is provided by the (K), whereas bore-safe delay action is provided by arrangement of mechanism within the booster

Functioning. No action takes place in the fuze upon firing until sufficient rotational speed has been established to overcome the resistance of springs and setback force on the several safety devices. When projectile with fuze set for SQ action leaves the muzzle of the weapon, centrifugal force will cause interrupter (K) to move outward, thus opening the passage. At the same time, the plunger pins (S) locking the delay plunger assembly in unarmed position also move outward, releasing that assembly for preparation for impact. The plunger pin lock (R) then swings on its pivot under centrifugal force, placing an arm against the inner end of each plunger pin (S), thereby preventing the return of the pins to the unarmed position. Upon impact, the firing pin (D) of the SQ element is driven against the detonator (E), initiating the SQ action. Inertia causes the delay action plunger of assembly (M) to move forward, driving the primer (P) against the delay firing pin (N) and initiating the delay action thru BkPdr pellet (Q) and relay (T). The impulse is transmitted to booster (U) and then to the main charge of projectile. In normal functioning with SQ action, the delay action has no effect since the SQ train would have caused the projectile to explode before the delay train can burn for its prescribed time. However, should the SQ action fail, the projectile will function with delay action rather than become a dud. When set for delay action, the inter-



Fig 1-75 FUZE, PD
M52A1

rupter (K) which closes the SQ passage is restrained from moving. Upon impact, the SQ firing pin (D) and detonator (E) function but the effect is prevented from being transmitted to the booster (U) and the projectile

PD M51A5 has been used in 155-mm Howitzer and 8-inch Howitzer when PD M557 was not available. Fuze M557, described in Ref 52, pp 5-45 to 5-47 might be considered as a modification of M48 and M51 series and its functioning is similar to that of M48 and M51 fuzes. These fuzes are also described in Ref 20a, pp 283-87

Fuzes, PD M52A1 and M52A2. These fuzes described in Ref 52, pp 5-19 to 5-20; Ref 17, p 161; & Ref 20a, pp 287-88 were fitted to 60-mm and 81-mm mortar cartridges, but they are replaced now with their modified versions which are fuzes M525A1 and M525. All of these fuzes are single-action types with direct action firing devices. As fuzes M525A1 & M525 are only briefly described in Ref 52, p 5-37 and no Figs are given, we are describing here their prototype M52A1 and reproducing here Fig 158 taken from Ref 20a, p 288, because Fig 5-9 of Ref 52,

p 5-19 is not very clear. Fuze M52A1 (our Fig 1-75) consists of two major parts: a head (D) which holds the firing pin (C); and a body (L) which contains a slider (F), a detonator (I), a booster lead-in (J) and a Tetryl booster pellet (K) in a booster cup (O) screwed into the base of the fuze body (L). The firing pin assembly consists of a firing pin (C) secured to a cup-shaped striker (A). The striker is supported by a spring (B), which holds the pin (C) at a safe distance from the detonator (I) during the flight of the projectile. The entire firing pin assembly is held within the fuze head (D) by a pin (E), located near the pointed end of the firing pin (C). Boresafety is provided by holding detonator (I) out of alignment with the firing pin (C) by means of a slider (F) (known also as interrupter), which is held in the unarmed position by a long safety bore-riding pin (G). The pin (G) is held, in turn, in the unarmed position by a setback pin (N) through which a safety pull pin (M) passes. This pin (M), which protects fuze during shipment and handling, must be pulled immediately before the round is dropped in the mortar for firing

Functioning. Upon firing, setback causes the setback pin (N) to move backward against the resistance of the spring (S). This releases the safety bore-riding pin (G), which is held in the fuze by the inner wall of the mortar tube, and the pin is ejected from the projectile as it emerges from the muzzle of mortar. As result of this, the slider (F), which is guided by the guide pin (H), moves into armed position. Upon impact, the striker (A) is driven inward compressing its spring (B) and carrying the firing pin (C) against the detonator (I). Action of the detonator is transmitted thru the booster lead (J) to the Tetryl booster pellet (K) and thereby, to the bursting charge of the projectile

Fuze, PD, M53A1 used with 81-mm HE trench mortar cartridges is not described because it is very similar to Fuze M52A1 described above (Ref 17, p 162; Ref 20a, pp 289 & 291 and Ref 52, pp 5-20 & 5-21)

Fuze, PD, TSQ, M54. It is a combination of superquick (SQ) and time (T) action (with settings up to 25 seconds) fuze for use with base-ejection smoke and illuminating shell. It is identical with the M55 series, except that M55 models have a booster assembled to the fuze. The fuze consists of three major parts: 1) A closing cap or head (A) contg the SQ impact element (B, C, E) and the time-action plunger (F); 2) Two time-train rings, one fixed (K) to the body and the other movable (P); and 3) A body (R) contg a time-action striker (H), a primer (V), a magazine charge (T), and an interrupter (S). The SQ action is identical with those in the M48 and M51 series, except that interrupter (S) incorporated in the body (R) of the fuze has no setting sleeve, being automatic and always operative, regardless of fuze setting. Hence, the fuze will function on impact unless prior time functioning took place. The time action is typical of powder-train types and is initiated upon firing by the time-action plunger under setback. The rings (K & P) have a tunnel-shaped slot or groove in their lower surfaces, which is filled with compressed BkPdr (N). One end of the lower ring is connected by a BkPdr pellet (U) with the upper ring train (K). The

other end of ring (K) is connected by a pellet (L) with the primer (V). Turning of movable ring (P), in relation to ring (K) and pellet (Q), counterclockwise (viewed from the point of the fuze), lengthens the time by increasing the amt of powder which must burn in both rings before the flame reaches (Q) in the body (R) and the magazine charges (T) See Fig 1-76

When used with M20 and M21 series booster, boresafety is provided by the arrangement of the booster mechanism. Provision is also made for boresafe SQ action by the interrupter (S), which shuts off the SQ flash-hole (J) until sufficient rotational speed has been established. A metal cup-shaped support (C), which is sufficiently strong to withstand initial setback, holds the SQ element firing pin (B) away from the detonator (E) until impact at the target. When the fuze is set "safe" ("S"), the rings (K & P) are positioned so that either or both may burn without causing functioning of the succeeding elements of the time train. To prevent functioning within dangerously short time limits, a safety disk incorporated in the rung (P) covers the pellet (Q) to prevent its ignition when the fuze is set at less than 0.4 second. A pull (safety) wire (D) and a shear pin (G) are fitted in the time-action plunger to prevent accidental functioning of the plunger prior to firing. The safety pull-wire must be removed before firing

Upon firing, with the safety wire removed, setback causes the time-action plunger to shear the wire (D) and force the striker (H) against the primer (V). Its flash ignites the pellet (L) and the train in upper ring (K), which then burns at a relatively uniform rate. The burning proceeds until the flame contacts and ignites the pellet (U) of lower ring (P), unless the fuze is set at safe ("S"). The flame from (U) ignites the ring (P) which burns during a time set by the scale on the outside of the fuze. Then the pellet (Q) in the body (R) is ignited unless the setting is less than 0.4 second. In this case, the flame from (P) is interrupted before making contact with (Q), and time action is stopped at this point. If setting is higher than 0.4 sec, the pellet (Q) is ignited and the flame is transmitted to the magazine charge (T). This chge initiates the booster inside the main chge of

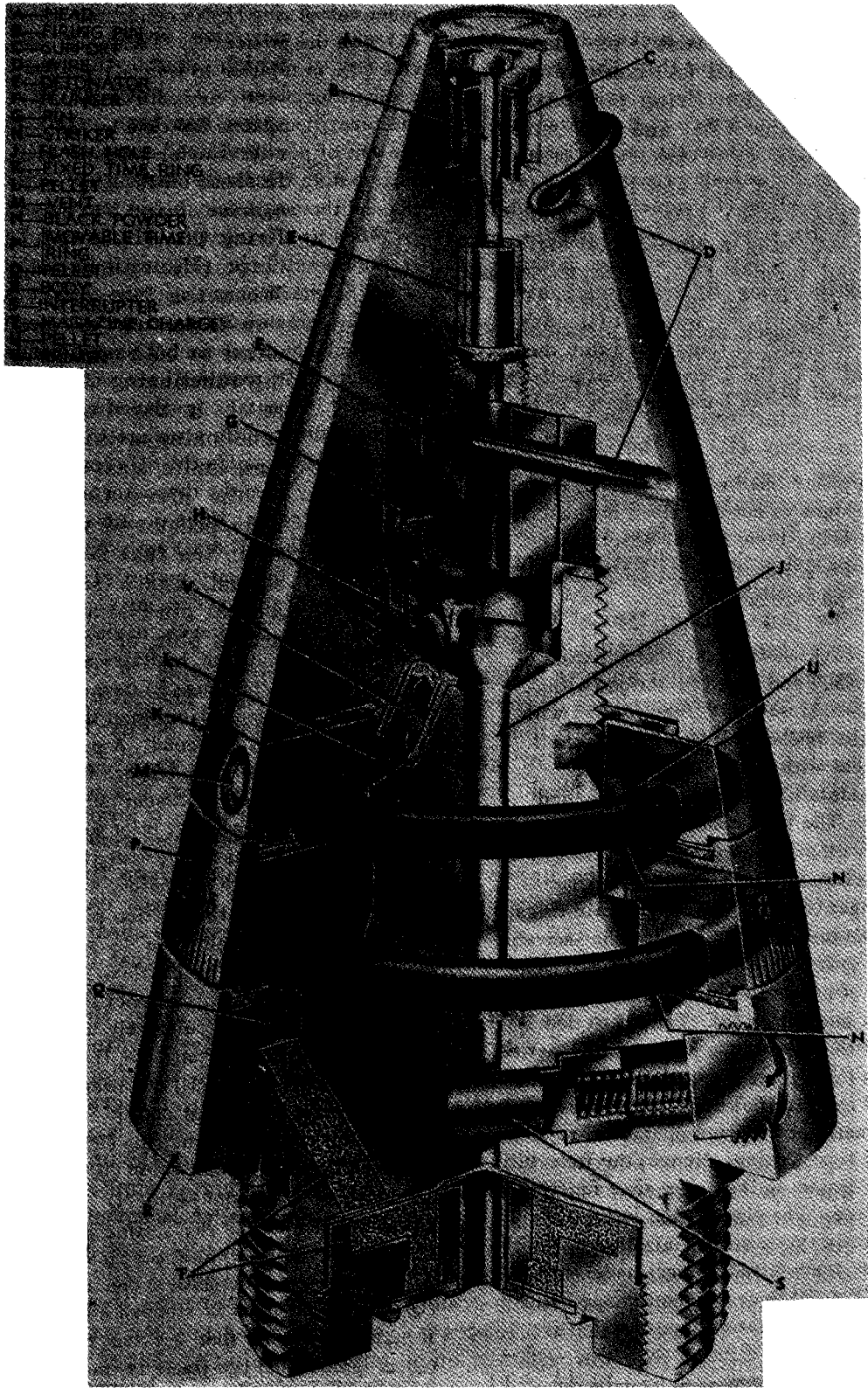

Fig 1-76 FUZE, PD, TSQ, M54

the projectile, unless prior functioning has been caused by the SQ action on impact. The SQ action becomes armed when sufficient rotational speed has been established to force the slider of interrupter (S) outward against the resistance of its spring and thereafter remains operative until impact unless the time action has completed its functioning during the flight. Upon impact, the firing pin support collapses and the SQ pin (B) strikes the detonator (E). Action of (E) is transmitted directly to the shell booster thru the uninterrupted flash hole (J). The fuze will function on impact, therefore, with SQ action, when the time setting is set for a time greater than the time of flight, or otherwise fails to complete its functioning.

The gases formed on burning of both powder train rings escape thru vents (M) (Ref 20a, pp 291-97; Ref 17, pp 156-57 and Ref 52, pp 5-96 to 5-99)

Fuze, TSQ M55 and Modifications. Fuzes M55A3, M55A2, M55A1 and M55 are used with HE projectiles primarily for high burst ranging. They are identical in every respect with Fuze M54 (See previous item), except the size. The booster M21 series is a manufacturing component of Fuzes M55 (Ref 52, pp 5-99 & 5-100 and Ref 20a, pp 294 & 297)

Fuze, PD M56. It is a supersensitive type used with 37-mm HE shells. The fuze consists of the following parts (See Fig 1-77), joined by threads: a nose (B), a head assembly (F) and body (L). The body holds the booster charge (M) and an interrupter (N) which contains a part of the explosive train connecting the booster with the detonator (H), which is located in its assembly (G) screwed into recess of head assembly (F). The nose (B) holds the firing pin (C) and screws into the upper end of the head (H) in such a manner as to leave a recess below the firing pin (C). Half-blocks (E) and a coiled spring (D) are positioned in the recess to hold the pin (C) in an unarmed position prior to firing. The front end of the nose (B) is closed with a thin Al disk (A) for protection against foreign matter or air resistance.

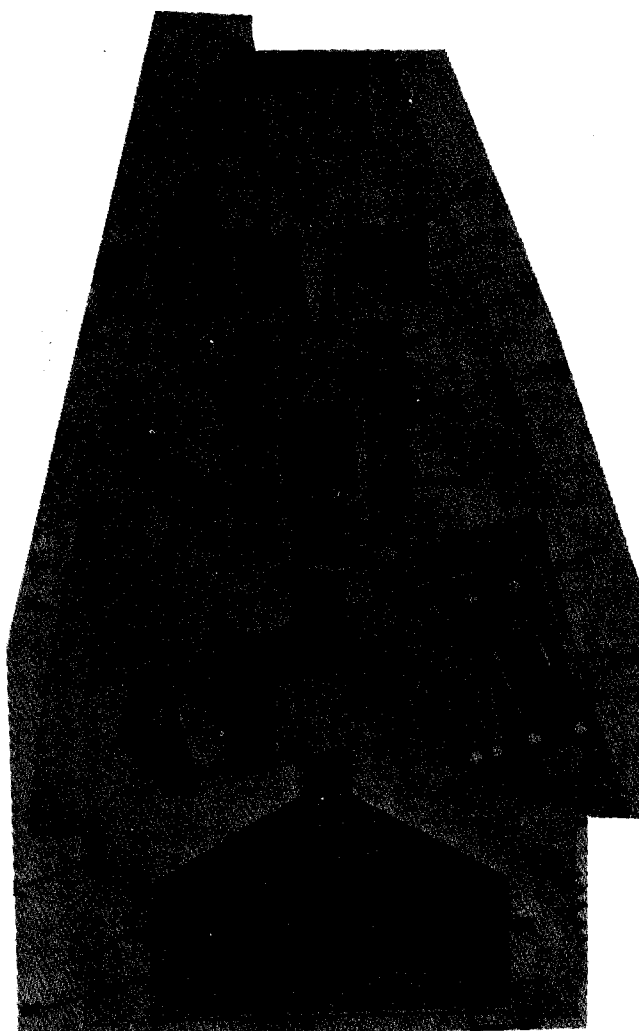

| | |
|----------------------|------------------|
| A-DISK | H-DETONATOR |
| B-NOSE | J-SLIDER |
| C-FIRING PIN | K-SLIDER CHARGE |
| D-SPRING | L-BODY |
| E-HALF-BLOCKS | M-BOOSTER CHARGE |
| F-HEAD | N-INTERRUPTER |
| G-DETONATOR ASSEMBLY | |

Fig 1-77 FUZE, PD, M56

Safety in handling and boresafety are provided for by half-blocks (E) and interrupter (N) devices, which hold the fuze in an unarmed condition until sufficient rotational force overcomes resistance of springs, setback, and friction.

Functioning. When sufficient rotational speed has been established to offset the resistance of springs, setback and friction, the slider (J) of the interrupter (N) moves outward

bringing the slider chge (K) into alignment with the detonator (H) and booster (M). While in the bore of the gun, setback causes the firing pin (C) to set firmly in the half-blocks (E), preventing them from flying outward. Upon leaving the bore, the firing pin (C) creeps forward. The half-blocks holding the pin (C) in the unarmed position against the coiled flat steel spring (D) then move outward under centrifugal force, leaving the firing pin in a floating position with an unobstructed passage to the detonator (H). Upon impact of the projectile, the thin closing disk (A) is perforated, or the head (B) is crushed depending on the force of impact. In either case, the firing pin is driven against the detonator and initiates it. The action of detonator is transmitted thru the slider chge (K) to booster (M), which then causes the burster chge of the projectile to explode (Ref 52, pp 5-22 to 5-24; Ref 17, pp 146-47; and Ref 20a, pp 295 & 297-98)

Fuzes, PD M57 and M57 Modified are single-action SQ type of the same construction as M48A3 (without delay element) or M51A5 (without booster). Fuze M57 has been used primarily with 75-mm smoke cartridge, and in conjunction with booster M22 in 105-mm smoke cartridge. As booster M22 has no interrupter, the combination of fuze M57 and booster M22 is not considered as falling strictly within the definition of "boresafe". However, since the fuze, itself, contains an interrupter, the combination may be used under conditions requiring boresafety. Fuze M57 has been superseded for such use by M43A3 with 0.05-sec delay in 75-mm smoke cartridge M64 and by fuze M51A5 with 0.05-sec delay in 105-mm Howitzer smoke cartridge. Fuze M57 is described in Ref 52, pp 5-24 & 5-25 and represented in Fig 5-12. We are omitting its description since it is similar to M51 series already described here. M57 is also described in Ref 17, pp 151-52 and Ref 20a, pp 298-99

Fuze, Time, Mechanical M61. See under Mechanical Time Fuzes

Fuze, PD M64A1, described in Ref 17, pp 148-49, was replaced by the Navy Mk27 fuze shown here on Fig 1-73

Fuze, Time (Fixed), M65A1 or M65. It is used with the 60-mm illuminating mortar shell to obtain the delay in functioning required for optimum illumination. It differs from the adjustable powder-train types (such as M51 and M54 series) in that the burning time is fixed at ca 15 seconds; therefore, this type has no movable time ring and requires no adjustment. This delay permits the round to be at its optimum range and height before the illuminant begins to burn. The fuze M65A1, cylindrical in shape (See Fig), contains the items indicated below the Fig. Upon firing, setback causes striker (C) to move rearward with a force sufficient to

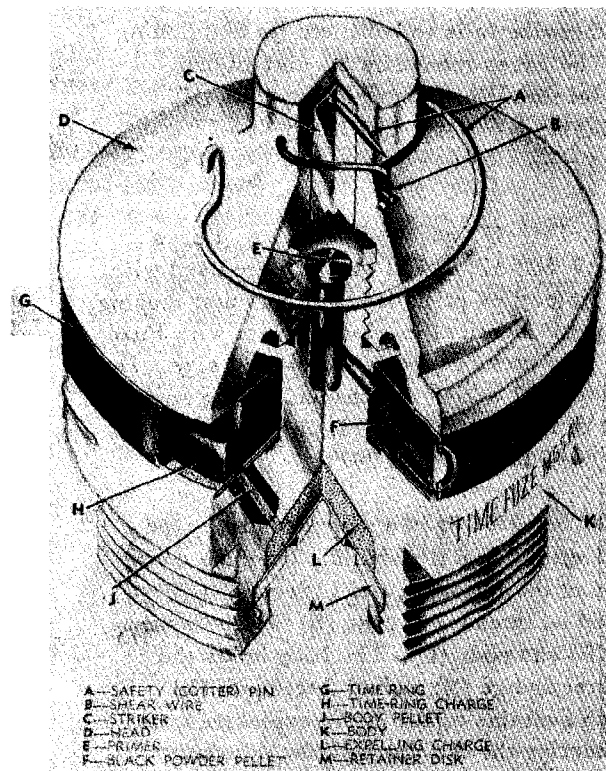

Fig 1-78 FUZE, TIME (FIXED), M65A1

shear the wire (B) and strike the primer (E). The flame from (E) ignites the BkPdr pellet (F), which in turn ignites the time-ring charge (H). After the flame has completed the circle about the ring (G), it ignites the body pellet (J) and this, in turn, ignites the expelling charge (L). Flame from the latter passes

thru the aperture in the expelling charge retainer disk (M), igniting the illuminant of the shell (Ref 52, pp 5-93 & 5-94; Ref 20a, pp 301-04 and Ref 17, pp 163-64)

Fuze M67. See under Mechanical Time Fuzes

Fuze, PD M71. It is described in Ref 17, p 149, but not in Ref 20a or Ref 52. It was used as an alternative to the Navy Mk27 fuze described above

Fuze, PD M74. It is a PD fuze contg a direct-action firing pin and a cylindrical rotor provided for use with the M92 practice shell in 37-mm subcaliber ammunition. It is described in Ref 17, pp 147-48; Ref 20a, p 305; and Ref 52, pp 5-25 & 5-26

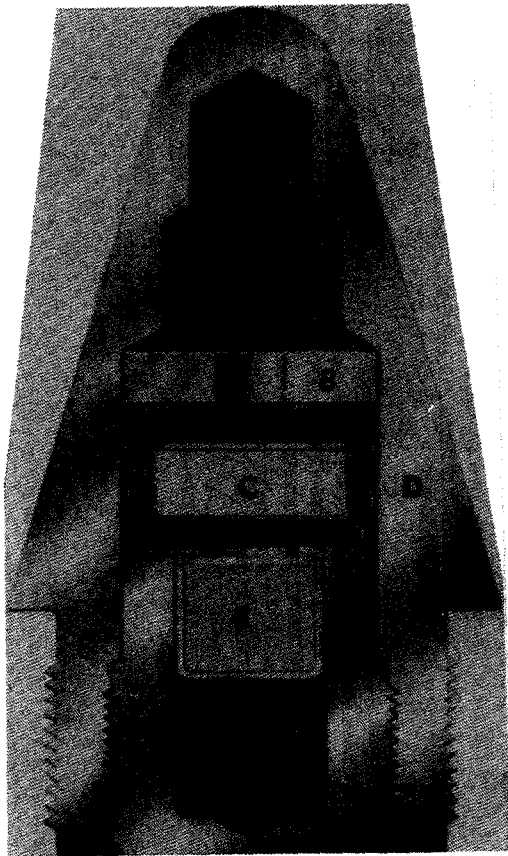

Fig 1-79 FUZE, PD, M75
(Modification of Navy's Mk 1)

Fuze, PD M75 (Modification of Navy Mk 1). It is a single-action SQ type intended to function with percussion action in 20-mm HE incendiary ammunition on impact with aircraft targets. Its design (See Fig 1-79) differs from the ordinary fuze in that it has no detonator safety and no arming firing pin. The fuze is made up of two major parts: 1) A body (D) with an air space (A) in the forepart of the fuze; and 2) A magazine contg explosive train, which consists of MF detonator charge (C), an intermediate charge of LA (E) and Tetryl base charge (F), which serves also as a booster. The magazine is screwed into the base of body (D) to seat against an A1 impact disk (B). The solid nose of the body is intended to effect just the right delay for functioning inside a plane, preferably in the gas tank. The fuze requirement is that it shall not function against a 0.012-inch steel plate but must function against a 0.083-inch plate. On firing no function takes place until impact with a target sufficiently resistant to crush the nose of the fuze. This crushing combined with inertia of the disk (B) sets off the priming chge of detonator (C) and this is followed by detonation of (E), (F) and main chge of the shell. Initiation may also be caused by pieces of metal from the body striking (C), or by compression of the air column (with the accompanying formation of heat) forward of the detonator chge, or by combination of any or all of these. The fuze is very small, slightly longer than 1 inch and weighing ca 350 grains (Ref 17, pp 145-46 and Ref 20a, pp 306-08) (Not described in Ref 52)

Fuze, TSQ, M77. It is a combination fuze which provides either time functioning for airbursts or superquick impact action when used in 81-mm mortar HE or smoke ammunition. It incorporates features such as time rings and safety devices from fuzes M52A1, M53A1 and M54. Its three cuts are presented in Fig 1-80. Prior to firing the shell, remove both cotter pins (C and J). When fired, setback causes the time-action plunger assembly (B) to break the shear pin (D) (supporting it) and strike the time-train primer (E), thus igniting

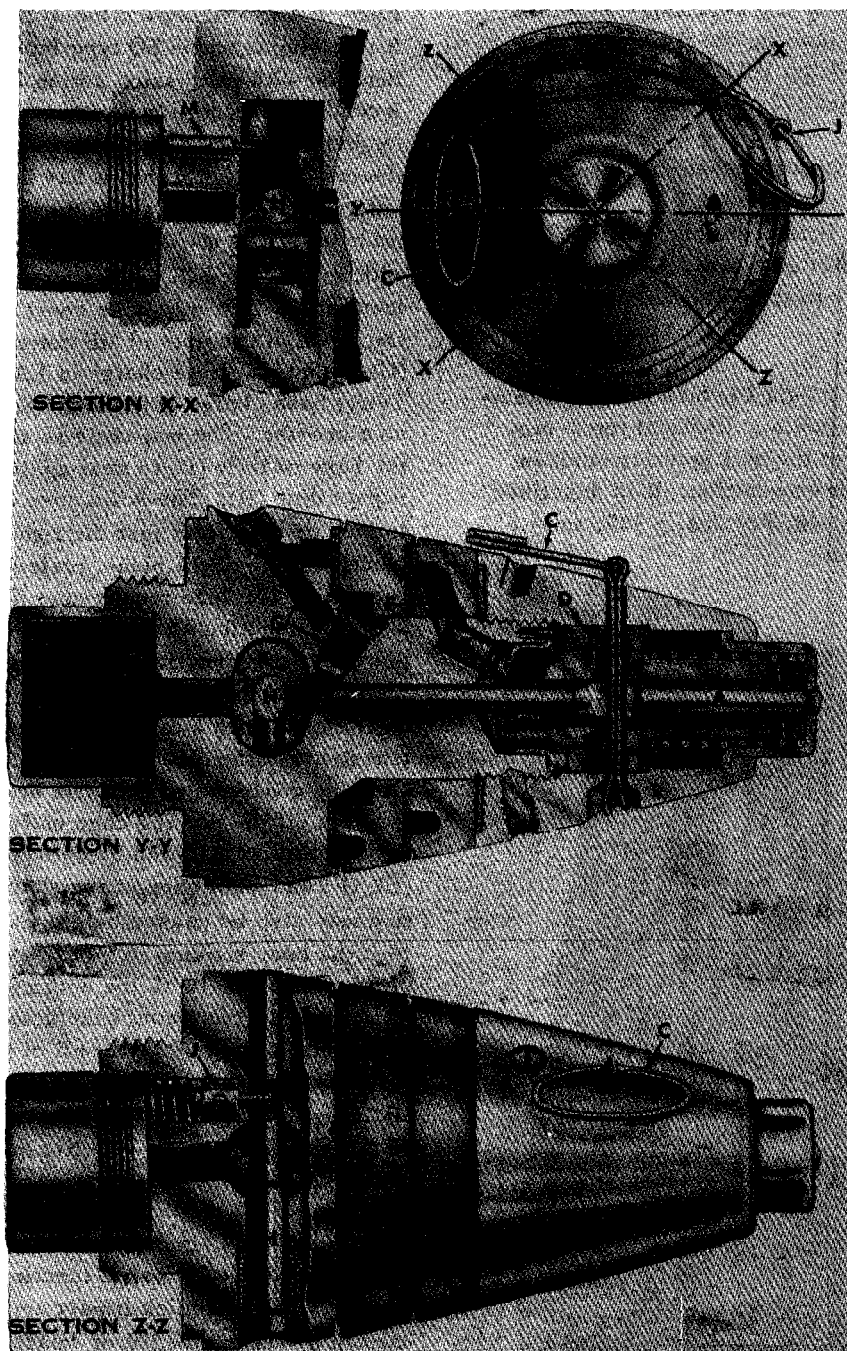

Fig 1-80 FUZE, TSQ, M77

its and pellet's (F) chge. If the setting on dial of time rings is more than 0.8 sec, the flame will go thru time rings. At the same time, setback retracts the bore-riding setback

locking pin (I) which releases the bore-riding pin (H). This pin is ejected by its spring from the fuze as soon as the shell leaves the mortar tube. The slider assembly (K)

is then moved by its spring so that the detonator (L) is in line with firing pin (A) and booster lead (N). A guide pin (M) keeps the slider assembly (K) properly aligned. If the fuze is set for time action, the powder train burns for the designated time and initiates the relay pellets (G), which, in turn, initiate the detonator (L), and then thru lead (N) the booster (O) and main chge of the shell

In case of impact action, the firing pin (A), is, on contact with a target, depressed against its spring and strikes the detonator (L), which, in turn, sets off the booster and explosive chge of the shell (Ref 17, pp 162-63; Ref 20a, pp 308-10 and Ref 52, pp 5-100 to 5-102)

Fuzes, PD CP (Point-Detonating Concrete-Piercing), M78 & M78A1 and Booster M25. M78-series fuzes are constructed for use against concrete targets and are issued with HE projectiles of 76-mm thru 280-mm. They are of nondelay and delay types. The nondelay type is used primarily for spotting purposes, while the delay type for firing against concrete targets. The delay is 0.025 seconds.

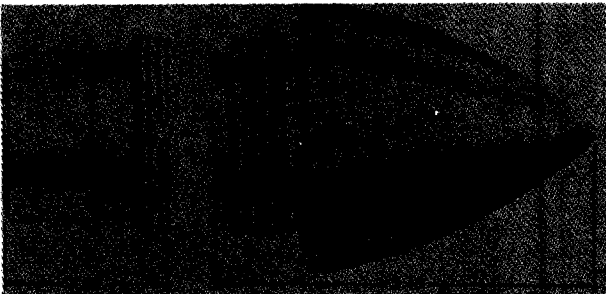

Fig 1-81 FUZE PDCP, M78

The booster M25, designed especially for M78-series fuzes, is a separate item. The fuze consists of a solid hardened steel body with ogival nose (See Fig 1-81) with a cylindrical well in the base end which holds an inertia firing mechanism. The firing mechanism is similar to the delay plunger mechanism in fuze M51A4 and the mechanism used in M78A1 is similar to that of fuze M51A5, already described here. Safety devices consist of two plunger

pins which hold the firing assembly in the unarmed position until acted upon by rotational forces, and arrangements within booster M25 which prevent arming until setback and centrifugal forces operate (Ref 52, p 5-26; Ref 17, p 154; and Ref 20a, pp 310-12)

Fuze, PD M81. It is a superquick and 0.05 sec delay fuze, similar in contour and mechanism (except the booster) to M51 fuzes. It was designed for use with the 4.5-inch spin-type rocket because it can arm with the relatively low setback characteristics of a rocket, but it can also be used with 8-inch HE shell (Ref 20a, pp 312 & 314)

Fuzes, PD M82, M82A1 and M82A1B1, designed for use in 60-mm mortar smoke cartridge M302, are modifications of fuze M52A1B1 to provide a small 10-grain booster charge. Their description is given in Ref 20a, p 314 with Fig 172 and Ref 52, pp 5-27 & 5-28 with Fig 5-15

Fuze, Time, M84. It is a single-purpose, powder-train, selective-time type used with the 81-mm illuminating cartridge. Its parts are shown in Fig 1-82. For its functioning, the safety wire (C) is removed leaving the plunger (F) held in a fixed position by two shear pins (E). After firing the setback force causes the plunger (F) to shear these pins (E) and to move to the rear along the plunger guide (B) until it strikes the primer (G), thus initiating burning of the powder train of the time-train rings (K & M). A positioning pin (D) is provided for plunger guide. After burning thru the total length of powder train (determined by setting the lower time-train ring by means of adjustment ring), the burning train ignites the BkPdr pellet and expelling chge (S). This chge then produces the desired functioning of the cartridge (Ref 17, p 164; Ref 20a, pp 314-16 and Ref 52, pp 5-94 to 5-96)

Fuze, PD M85. It embodies the same characteristics as described above for the M56 super-sensitive fuze used with 37-mm HE shell, but is modified as to length and weight of the

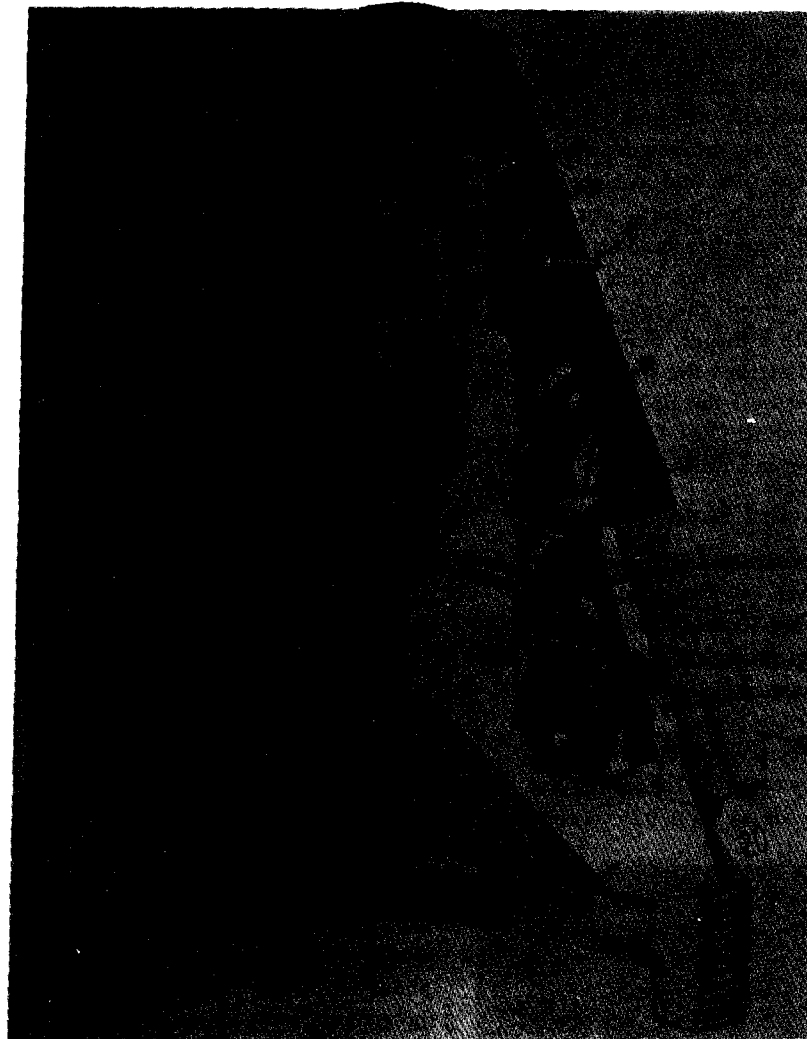

- | | |
|-----------------------------|---------------------------------|
| A —HEAD | K —UPPER TIME-TRAIN RING |
| B —PLUNGER GUIDE | L —LOCK PIN |
| C —SAFETY WIRE | M —LOWER TIME-TRAIN RING |
| D —POSITIONING PIN | N —ADJUSTMENT RING |
| E —SHEAR PIN | P —VENT HOLE |
| F —PLUNGER | Q —RIB |
| G —PERCUSSION PRIMER | R —LOCK SCREW |
| H —SETSCREW | S —EXPPELLING CHARGE |
| J —WASHER | T —BODY ASSEMBLY |

Fig 1-82 FUZE, TIME, M84

assembly to suit 57-mm HE shell and to match the M86 fuze. Fuze M85 is described in Ref 20a, pp 316-18, but not in Ref 52

Fuze, PD M86. It is provided for use with 57-mm HE shell to give superquick functioning on impact. It resembles M85 in contour but its mechanism differs in that the M86

incorporates a spherical-rotor type interrupter which operates in conjunction with a safety spring to provide boresafety, instead of having a slider-type interrupter and safety blocks. The fuze is described in Ref 20a, pp 318-20, but not in Ref 52



Fig 1-83 FUZE, PD, M89

Fuze, PD M89. It is a single-action type providing superquick functioning on target impact. It arms at relatively low speeds of rotation and is intended for use in 57-mm recoilless rifle ammunition. The fuze (See Fig 1-83) is made up of either a one piece Al body (E), or, as an alternative, of two parts: Mechanism consists of a lightweight firing pin (D) seated in a cavity at the forward

end of the fuze and held in a fixed position, prior to impact at the target, by a gilding metal firing pin support (C). The striker cavity is closed at the outer end by an Al closing disk (A) supported by a brass washer (B). A rotor (G) housed in a cavity perpendicular to the fuze vertical axis holds the detonator (F). The rotor with its detonator is held in an unarmed position by a lock assem-

bly (I) by means of two nipples which seat in two drill holes in the rotor under the lock spring (S) against the lock. A body pin (J) serves to hold the spring and the spring cup in proper position and as a guide during outward movement of the lock. A closing plug (H) seals the rotor cavity against moisture and foreign matter. Explosive elements consist of the detonator, the lead charge (K) of Tetryl and a booster charge (L) of Tetryl held in an externally threaded Al booster cup which is screwed and staked into the base of the fuze. Boresafety is provided by the rotor and lock mechanisms. The firing pin is protected against premature functioning by its cup support which is designed to withstand a load up to 40 pounds

Functioning. After firing and upon establishment of sufficient rotational force, the lock moves outward against the tension of the lock spring (S) releasing the rotor (G). After setback is over, the rotor turns to the armed position [detonator (F) parallel to fuze axis and aligned with firing pin (D)]. This position is retained until impact, whereupon the Al closing disk (A) is perforated or crushed and the firing pin (D) is driven thru its cup support and against its detonator (F). Action of detonator is transmitted thru booster lead (K) to booster (L) and then to the bursting charge of the projectile (Ref 20a, pp 320-22 and Ref 52, p 5-29)

Fuze, PI (Point-Initiating), M90A1 (or M90). It is a single-action, SQ type designed for use with 57-mm HEAT projectiles. The fuze differs from PD fuze's in that initiation is by impact of the fuze primer directly against the target. The fuze is characterized by internal threads for engagement of the projectile and by shaped auxiliary detonating charge (H). The fuze (See Fig 1-84), consists of a diecast body (C) with a neck which houses the primer (A). A cavity in the middle of the fuze body, extending across the perpendicular to the fuze axis, holds a rotor (E) and a lock assembly (G). A body pin (F) serves to hold the lock cup and lock spring. The entire forward part of the fuze body and its mechanism is covered by a thin steel ogive (B). When sufficient rota-

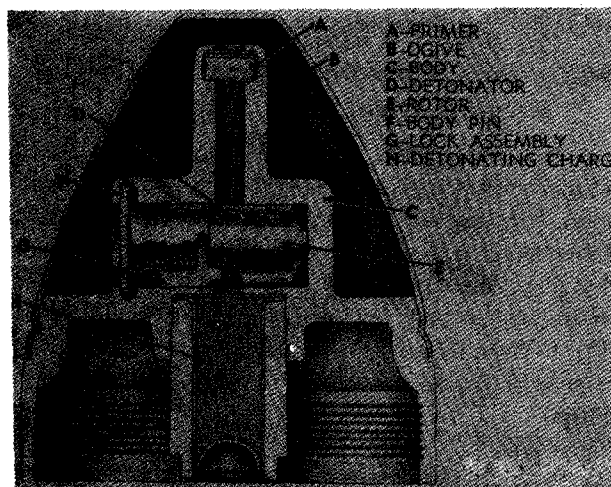
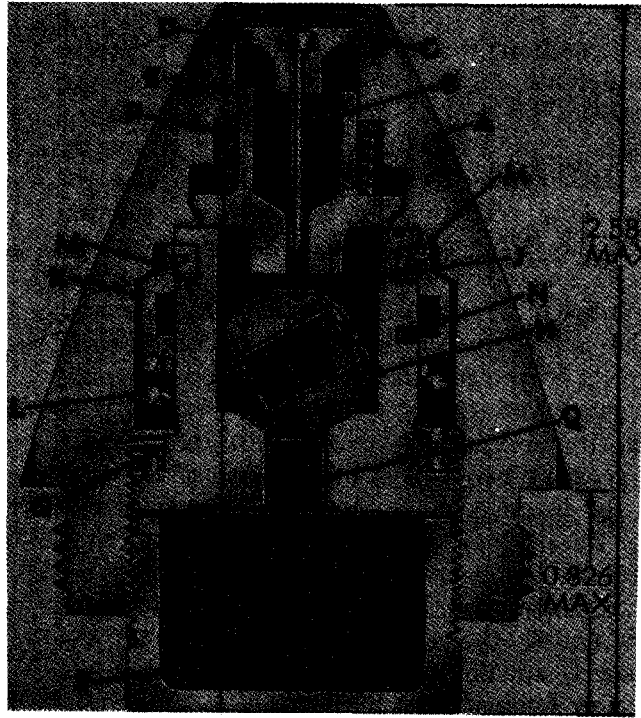

Fig 1-84 FUZE, PI, M90A1

tional (centrifugal) force is established after firing, the lock moves outward against its spring, releasing the rotor (E) to turn on its axis. After setback the rotor turns to the armed position, in which the detonator (D) is parallel to the fuze axis. Upon impact, the ogive (B) is crushed and the primer (A) is initiated, thus transmitting the detonation wave to (D), (H) and booster pellet at the base of the projectile flash tube (Ref 52, p 5-54) (Not described in Refs 17 & 20a)

Fuze, PD, SD T234E2. This point-detonating, self-destroying fuze was developed for use in 75-mm HE cartridge M334. After the cartridge travels 60 to 200 feet from the gun, the fuze will function if either nose or graze impact occurs within 30 seconds of flight time. Decreasing of rate of projectile spin will cause the fuze to detonate the cartridge. The fuze is listed in Ref 52, p 5-53 but not described except giving its overall length 5.979 inches, its visible length 3.761 and weight 2.03 lbs. Its photograph is given in Ref 52, but no drawing of its mechanism

Fuze, DA No 251, Mk I/L. It is a fuze for 40-mm ammunition adopted in 1941 from the British, who in turn adopted it from the Bofors Co of Sweden. Abbr "DA" means "direct action" which corresponds to Amer "superquick" and "L" means use on "land"



- | | |
|-----------------------------------|-------------------------------------|
| A —BODY | J —DETONATOR |
| B —FIRING PIN | K —SETBACK SLEEVE |
| C —FIRING PIN HEAD | L —SETBACK SPRING |
| D —SUPPORT CUP | M —HALF-BLOCK RETAINER |
| E —ROTOR RESTRAINER | N —DETENT SPRING |
| F —ROTOR RESTRAINER SPRING | P —BOOSTER PELLET |
| G —ROTOR HOUSING | Q —BOOSTER LEAD CUP ASSEMBLY |
| H —ROTOR | |

Fig 1-85 FUZE, PD, M503A1

(as against the 20-mm ammo originally designed for the AC gun). The fuze is described in Ref 17, pp 147-48. Being a very complicated device for a single-purpose fuze, the No 251 has been replaced by simpler designed fuzes such as Navy, Mk 27 and PD M64 & M71 (See our Fig 1-73)

Fuzes, PD, M503A2, (M503A1 and M503) (Ref 52, p 5-28). Fuze M503A2 designated for use in 57-mm recoilless rifle projectiles, is a single-action superquick type which functions by impact or graze after an arming delay which is in effect for about 60 feet from the rifle. The fuze (See Fig 1-85), consists of an Al body (A), recessed at the forward end to hold

a steel firing pin (B), which is held in an Al firing pin head (C), and supported by a gilding metal support cup (D). Threaded to the rear of the body is a booster cup contg a pellet (P). The pointed end of the firing pin projects into an Al rotor restrainer (E) which is held in place by a rotor restraining spring (F). An Al rotor housing (G) contains a brass spherical rotor (H) with a detonator (J) and a booster lead cup assembly (Q). An Al setback sleeve (K), which fits around the rotor housing, is held in its forward position against two half-block retainers (M) by a steel wire setback spring (L). The retainers (M) are held in position against the rotor housing by its detent spring (N). In the unarmed position, four brass detents (not shown in Fig) are held

against the rotor by the setback sleeve (K) and the detent spring (N), preventing rotor from turning

In functioning, the setback force, incident to firing, displaces (K) to the rear against (L). In this position (K) continues to hold the detents in the locked position, thereby preventing the rotor (H) from turning. Centrifugal force, due to rotation of projectile (ca 9000rpm), causes both (M's) to move outward against their spring. Upon deceleration, the groove setback sleeve (K) moves forward against (M's), to occupy the new position in which the groove is opposite the detents. In this position, the four detents, acted on by centrifugal force, move outward against their detent spring (N) into the groove in (K), thus freeing the rotor (H) to turn so that it can align the detonator (J) with the firing pin (B). The turning is caused by unbalanced forces exerted on the rotor due to differences in density between the detonator and brass rotor. During flight, the rotor restrainer and its spring prevent the rotor from creeping forward and firing the detonator, but this takes place either on impact or on graze. When impact of nose of the fuze on target takes place, the firing pin is driven into the detonator. When contact is made at a point to the rear of the nose graze, the inertia of the rotor causes it to move forward, overcoming the resistance of the spring (F) and carrying the detonator forcibly against the firing pin. The pin, striking the detonator, initiates the explosive train of the projectile

Fuze M503A2 differs from M503 and M503A1 in that it has a setback sleeve, a setback spring and half-block retainers which provide added safety

Fuze, PD M507. It is a dual-purpose (SQ and delay) type fuze designed for use on HE projectile M73 fired from the 120-mm AA cannon. It is described in Ref 52, p 5-30, but no drawing is given

Fuzes, PD M508A1 and M508. They are single-action types, designed for use with 105-mm, 155-mm and 85-mm chemical (gas or smoke) projectiles. Their brief description is given in Ref 52, pp 5-30 & 5-31, but no drawing of their mechanisms is included

Fuze, PD M519 (T319). It is a combination of PD Fuze M52A2 (described above) with a Fuze Adapter T211, designed for use with 81-mm cartridge. It is a single-action type with a direct-action firing device (Ref 52, pp 5-31 & 5-32, Fig 5-18). It is being replaced by the M526 series (Ref 52, p 5-42)

Fuze, PD M521 (T247). It is an impact-type, delay & SQ fuze, similar to M51A5 (described above), except that it does not have a booster (Ref 52, pp 5-32 & 5-33; outside view given in Fig 5-19)

Fuze, PD M524 Series. This dual purpose, SQ or 0.05-second delay fuze is used in 81-mm mortars with HE cartridges M362 Series & M374; or with WP (white phosphorus) smoke cartridges M370 & M375. It can act on impact or graze contact with greater sensitivity and speed than fuzes formerly used with 81-mm ammunition

The fuze is described in detail in Ref 52, pp 5-33 to 5-37, where cutaway views are given in Figs 5-21 & 5-22 for the fuze in unarmed and armed positions

We are not including this fuze, preferring to describe its modification known as FUZE, PD XM593 (See our Figs 1-87 & 1-88)

Fuze M524A5 has been used by the Army, while its modified version, designated as M524E7 has been used by the Navy and by the Marine Corps. This version contains two safety pins and the fuze plunger is redesigned so as to prevent the removal of the plunger safety pin if the arming mechanism starts to arm

Fuzes, PD M525A1 and M525. These fuzes are modifications of M52 series. The modification consists of a head assembly which contains a delayed-arming mechanism in addition to the firing pin mechanism of Fuze M52. Fuzes of M525 series have been used with 60-mm HE cartridge M49A2; the 81-mm HE cartridges of the M43 & M56 series; 81-mm target practice cartridge of the M43 series, and the 81-mm WP smoke cartridges of the M57 series (Ref 52, p 5-37 to 5-40; Figs 5-23 & 5-24)

Fuzes, PD M526A1 and M526. They consist of the former M52-series fuzes (described above), modified as in the case of M525 series, with an arming delay head and, in addition, fitted with an adapter contg auxiliary booster pellets to adapt it to newer design of 81-mm cartridges. These fuzes may be used instead of M524A1 in 81-mm HE cartridges of the M362 & M344 series and WP (smoke) cartridges M370 & M375. These fuzes are replacing the PD M519 fuze (Ref 52, p 5-42 and Fig 5-27 on p 5-43)

Fuzes, PD M527A1, M527 or M527B1 and M527A1B1. They are similar to the M525-series (listed above) except that they have a smaller booster charge and a 0.50-inch "intrusion" (the length of that portion of the fuze which intrudes and is partially housed within the missile). A brief description without a drawing of mechanism is given in Ref 52, p 5-43. They are intended for use in 60-mm WP smoke cartridge M302

Fuze, PD M535(T177E3). It is similar to fuze M51A5 (described above); except that there is a booster which provides a minimum delay arming distance of 35 feet (Ref 52, pp 5-44 & 5-45; no drawing of mechanism)

Fuze, PD M557. It is essentially M48A3 fuze assembled with booster M125A1. It is described in Ref 52, pp 5-45 to 5-47 and its drawing with list of parts is given in Fig 1-86.

Functioning: No action takes place in fuze upon firing until sufficient rotational speed has been established to overcome the resistance of springs and the setback force upon the several safety devices. When set for SQ action after the projectile leaves the muzzle of the weapon, centrifugal force causes the interrupter (K) to move outward opening the flashtube (G) passage. At the same time, the diametrically opposite plunger pins (S) that keep the delay plunger assembly (M) in unarmed position also move outward, releasing that assembly in prepn for impact. Each plunger pin lock (R) then swings on its pivot under centrifugal force, placing an arm against the inner end of its plunger pin, thereby preventing return of the pin to the



- | | |
|-----------------------|-----------------------------|
| A—Head | L—Interrupter spring |
| B—Superquick element | M—Delay plunger assembly M1 |
| C—Firing pin support | N—Firing pin (delay) |
| D—Firing pin (SQ) | P—Primer M54 |
| E—Detonator M24 | Q—Delay charge |
| F—Ogive or windshield | R—Plunger pin lock |
| G—Flashtube | S—Plunger pins |
| H—Body | T—Relay M7 |
| J—Setting sleeve | U—Booster M125A1 |
| K—Interrupter | |

Fig 1-86 FUZE, PD, M557

unarmed position. Upon impact, the firing pin (D) of the SQ element (B) is driven against the detonator (E), initiating the SQ action. In normal functioning with SQ action, the delay action has no effect, the SQ train will have caused the projectile to explode before the delay train can burn for its prescribed time. However, should the SQ action fail,

the projectile will function with delay action rather than become a dud. When set for delay action, the interrupter (K) which interrupts the SQ passage is restrained from moving. In case of impact the SQ firing pin (D) and detonator (E) function but the effect is prevented from being transmitted to booster (U). On the other hand, when the firing pin (N) strikes the primer (P), the shock is transmitted thru the delay (Q) and relay (T) to booster (U) and then to the main charge of projectile

Fuze, PD M572. It is an impact-type fuze similar to M557, except that is structurally reinforced by filling the ogive cavity with ca 2.5-oz of epoxy. The fuze is intended for use in 175-mm HE projectiles (Ref 52, p 5-47; no drawing)

Fuze, PD XM593. It is a dual-purpose (SQ or delay) type, considered as a modification of M524 Series, and intended for use with HE 90-mm XM591 cartridge. The modification involves a change in the arming mechanism; delayed arming has been shortened. Detent and related grooves in striker lug have been replaced by an index plate (not indicated on drawing). When cartridge is fired from recoilless rifle, fuze arms at a distance of 90 to 160 ft from the muzzle. A removable pull wire is provided for safety in transportation and handling. The fuze is described in Ref 52, pp 5-47 to 5-51, where drawings are given for fuze in unarmed position (See Fig 1-87) and in armed position (See Fig 1-88)

Upon firing of cartridge, resultant setback forces acting on fuze components cause trigger and spring-loaded segment of setback device assembly (Fig 1-87) to rotate approximately 130° in a clockwise direction, turning segment shaft to armed position. The segment is locked in this position by counterclockwise rotation of locking link, which prevents segment from returning to unarmed position. In armed position, flat section of segment shaft permits lever of setback device and its shaft to rotate clockwise once acceleration of projectile ceases. During acceleration of projectile in rifle tube, friction between rotor

and body of arming mechanism produced by setback forces prevents any movement of rotor. When acceleration ceases, force exerted by rotor stop pin (Fig 1-88) on lever shaft of setback device rotates lever and shaft in a clockwise direction until rotor stop pin is disengaged from setback device. The rotor is then driven by its drive spring to armed position. The plunger, being keyed to the rotor, rotates with it in a counterclockwise direction to armed position. The rotor and plunger rotate 260° from unarmed to armed position. During approximately 22° of this rotation, timing gear of the rotor meshes with drive shaft of timing device. Subsequent oscillation of the balance causes 0.20- to 0.33-second arming delay. Rotor and plunger move unopposed through the final 238° of rotation to armed position

In SQ setting, the fuze functions on impact when striker (Fig 1-88) is driven rearward. With the striker slot set at SQ index (Fig 1-87), firing pins impact both detonator M63 (T33E1) (Fig 1-88, Sec A-A) and delay element M2, producing SQ detonation of expl train. If the SQ train fails to initiate the projectile, the fuze will function on delay rather than become a dud

In delay setting, the fuze functions on impact when striker is driven rearward. With striker slot at D index, only delay element M2 is impacted (Fig 1-88, Sec B-B) and the expl train is initiated after 0.05 seconds. One firing pin falls into a specially designed hole or slot. The flash from the delay element M2 is transmitted by detonator M80 (T34E1) to RDX booster lead assembly, which in turn, initiates Tetryl booster and then main charge of the round. Should impact occur at an angle at which the striker is not driven rearward, inertia will then move the plunger forward, thus forcing delay element M2 against the delay firing pin of striker to initiate explosive train

Fuze, PD XM593E. It is similar to XM593, described above, except there are some improvements which are listed in Ref 52, p 5-51. No drawing is given there

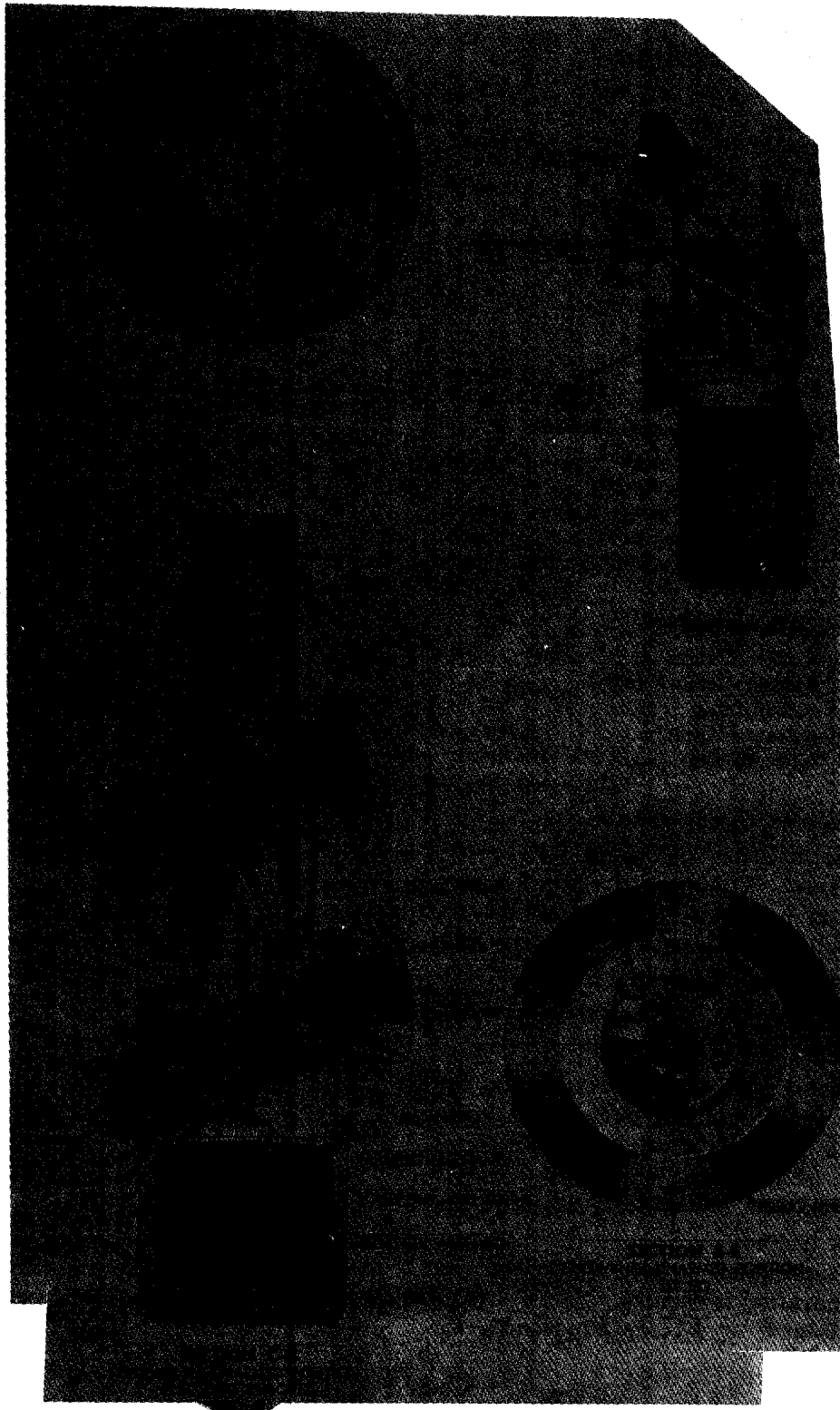

Fig 1-87 FUZE, PD, XM593 (Unarmed Position)



Fig 1-89 FUZE, MT, M43A4

clockwise as viewed from the point of fuze and reduced by turning in a counterclockwise direction. The desired time has been set when the register line on the lower cap is aligned with the appropriate graduation on the base. The lower cap may be turned in either direction and thru the zero and safety graduations. For accuracy in time of functioning, the time setting should always be approached from the same direction. Two

setting grooves, one each in the lower cap and base, are provided for fuze setting

The driving mechanism is based on the same principles as clockwork but differs in that it is driven by a pair of weighted gear segments (V) actuated by centrifugal force. Also the escapement (R) beats at a much higher frequency and makes use of a straight spring (Q). A timing disk with protruding lug and a notch is connected with the main

gear pinion at the upper end of the mechanism by means of a washer and Belleville spring device (F). This allows slippage during fuze setting but provides sufficient friction for the pain pinion to rotate the disk when the disk is released from the setting pin (B). In recent models, there is a safety leaf (H) immediately below the timing disk which prevents functioning should the fuze be set for dangerously short periods; in earlier models, the safety leaf was attached to the hammer (D). A striker assembly, consisting of a firing arm (J) and firing pin (M), is assembled in the mechanism so that it is released for functioning when the notch in the timing disk (G) becomes aligned with the finger on the upper portion of the firing arm. Explosive elements comprise a percussion primer (S), a BkPdr pellet (T) (omitted in earlier models), and a magazine charge (U) of BkPdr. Three main safety features make for boresafety: hammer (D) which acts on timing disk on setback, setback pin (K) which releases striker assembly on setback, and safety lock (P) which releases escapement on centrifugal action. Earliest models were fitted with a pull wire to prevent accidental rotation of the lower cap during shipment, but this has been omitted on more recent models

When setting the fuze, the turning of the lower cap (C) rotates the timing disk (G) by means of the setting pin (B) and upraised lug on the timing disk, causing the desired change in angular distance between the firing arm and the notch in the timing disk.

All other parts of the mechanism remain in position, since the gear train (N) and escapement (R) are locked by the centrifugal safety device. Upon firing, setback causes the hammer (D) on the cantilever spring (E) to strike the upraised lug on the timing disk, flattening the lug and releasing the disk from the setting pin. The hammer returns to its original position as soon as setback ceases. At the same time, the setback pin (K) which locks the firing arm (J) moves backward, leaving the firing arm free to turn when the notch in the timing disk comes opposite the finger on the firing arm. When sufficient centrifugal force has developed,

the safety lock (R) holding the escapement rotates and releases the escapement, leaving the movement free to run. The weighted gear segments (V) in mesh with the main driving pinion then drive the movement, the rate of rotation of the pinion, and therefore of the timing disk, being governed by the escapement through a series of gears. When the notch in the timing disk (G) reaches the finger of the firing arm (J), the firing arm turns, permitting the firing pin safety plate (L) to swing from under the firing pin flange, and allowing the firing pin to strike the primer (S) under the action of its spring. This initiates the action of the powder train, which action is transmitted to the booster and shell bursting charge

The fuze is set by means of a fuze setter, the lower cap being turned in a counter-clockwise direction as viewed from the point of the fuze to increase the setting, and clockwise to reduce it. In the case of early M43A1 fuzes, it is necessary to remove the pull wire before setting the fuze. This can be done readily by pulling the end of the wire from the hole in the lower cap and sliding the wire off the end of the fuze

Modifications. There are several modifications of the M43 fuze, and these differ as follows: The change from the M43A1 to the M43A2 consisted of a bevel in the shoulder so that the fuze could be screwed into the M23 booster. The change from the M43A2 to M43A3 resulted from a change in the method of regulating the movements. The change from the M43A3 to M43A4 resulted from the decrease in minimum functioning time from 1.67 seconds to 0.6 second. Since safe setting and torque required to turn the lower cap may be critical, these data are presented for the various modifications as follows:

| Modification | Minimum functioning time(sec) ¹ | Torque required to turn lower cap(lb-in) |
|----------------------------|--|--|
| ² M43A4 | 0.6 | 80 to 100 |
| M43A3 | 1.67 | 80 to 100 |
| M43A2 | 1.67 | 60 to 80 |
| ³ M43A1 (late) | 1.67 | 60 to 80 |
| ⁴ M43A1 (early) | 1.4 | 40 to 60 |

1 Fuze will not function if set below this figure

2 Upper cap painted red

3 Fuzes of late manufacture without pull wire

4 Fuzes of earlier manufacture with pull wire

(Ref 17, pp 157-59; Ref 20a, pp 278-82 and Ref 52, pp 5-57 to 5-60)

Fuzes, MT M61A2, M61A1 and M61. They are essentially M43A4 fuzes and are intended for use with 120-mm HE AA projectile M73 (Ref 52, p 5-60)

Fuze, MT M67A3. It is a modified version of M43A4 fuze and is intended for use with HE projectile for field guns ranging in calibers from 105-mm to 280-mm and also with 90-mm HE cartridge M71. Because of its longer time range, M67A3 fuze replaced M55 series TSQ fuzes for high-burst ranging with these calibers (Ref 54, p 5-62)

Fuzes, MTSQ M500A1 and M500. These fuzes are a combination mechanical time and super-quick action types with settings for time action (2 to 75 seconds) and an impact element for SQ action. The time action is based on the clockwork principle. Its description given in Ref 52, pp 5-72 & 5-73 does not include Figs of mechanism. Nevertheless we are including description of one of these fuzes

Fuze M500A1 consists of the following components:

- 1) Movement assembly. The movement assembly provides for the mechanical time action of the fuze. It consists of a firing pin and timing mechanism (clockwork)
- 2) Body. The aluminum body contains the explosive elements consisting of a primer and a relay and has the time

setting ring. It is externally threaded to engage booster M21A4

- 3) Booster M21A4. The forward end of this booster screws over the rearward end of the fuze body. The booster is threaded externally to engage the nose threads of the projectile
 - 4) Lower cap. The brass lower cap houses the major portion of the movement assembly and contains the setting pin and hammer spring. It is threaded internally at the forward end to receive the point detonator assembly
 - 5) Point detonator assembly houses the SQ impact element of the fuze consisting essentially of a firing pin and support and a detonator and lead charge
- Functioning:

- 1) Movement assembly. When the fuze is set, the turning of the lower cap rotates timing disk by means of the setting pin, which is engaged in the upraised lug. All other parts of the mechanism remain in position, since the gear train and escapement are locked by the safety lever assembly. Upon firing, setback causes the hammer spring to strike the upraised lug on the timing disk, flattening the lug and releasing the disk from the setting pin. The hammer returns to its original position as setback ceases. Setback also moves the setback pin toward the base of the fuze, leaving the firing arm free to turn when the notch in the timing disk comes opposite the upright on the firing arm. When sufficient centrifugal force has developed, the safety lever holding the escapement moves outward and releases the escapement, leaving the movement free to run. Simultaneously, centrifugal force augmented by backlash and the kickoff springs actuates the weighted gear segments which, in mesh with the main driving pinion, drive the movement. The rate of rotation of the pinion and, therefore, of the timing disk is governed by the escapement thru a series of gears. When the notch in the timing disk reaches the upright of the firing arm, the firing arm turns, permitting the firing pin safety

plate to swing out from under the firing pin flange. The firing pin then strikes the primer under the action of the spring. This initiates the action of the explosive train, which action is transmitted to the fuze booster and the projectile bursting charge

- 2) Point detonator assembly. The point detonator assembly functions independently of the movement assembly to provide superquick action; that is, it will function if impact occurs before the time setting or if the time is set as S (safe) on impact. Boresafety is provided in the point detonating assembly by a slider which interrupts the passage between the detonator and the lead charge. When the projectile is spinning sufficiently fast, the slider is moved outward by centrifugal force, providing an open passage between the detonator and lead charge, and thus arming the point detonator assembly

Fuze, MTSQ M501A1 (or M501). This fuze is similar to M500 except that it has no boosters and its threaded base is assembled directly into the projectile. The fuze is intended for use in the 155-mm Howitzer M1, M1A1 or M48 (Ref 52, pp 5-74 & 5-75)

Fuze, MTSQ M502A1 (or M502). Both fuzes are designed for AA use and M502A1 is superior to M502 because of additional safety features. Description of M502A1 (given in Ref 52, pp 5-75 & 5-76) is as follows: The impact element of this fuze is a supersensitive type designed to function on impact with thin aircraft surfaces that usually would not offer enough resistance to cause functioning of the more ordinary-type impact elements. The firing pin in the impact element is held in an unarmed position prior to firing by two half-blocks which, in turn, are held in place by a coil of spring wire. This wire also contains a 30-second clockwork-type timing mechanism that, except for its main pinion shaft, is fundamentally similar to that used in MT fuze M43A4. The main pinion shaft, made tubular, serves as a flash tube to carry the

flame initiated on impact thru the clockwork mechanism. Fuze M502A1 (or M502) is ballistically interchangeable with MT M43A4. The 30-second clockwork timing mechanism makes the fuze boresafe

Functioning (superquick). The SQ impact element becomes armed when the half-blocks holding the firing pin in the unarmed position move outward under centrifugal force caused by rotation of the projectile. The firing pin is left in a floating position with unobstructed passage to the detonator. Action of the detonator is augmented by the lead charge and is transmitted thru the uninterrupted flash tube to the relay in the closing plug and thence to the booster which explodes and sets off the cartridge case. Mechanical time functioning is the same as described under MT fuze M43A4

Fuze, MTSQ M506 (T176E3) [w/Booster M124 (T35E8)]. This fuze was designed to replace MT M61A2 (with booster M21A4) for use with the 120-mm HE projectile M73. While fuze M61A2 functions only by time action, fuze M506 combines impact and time action. The time action of M506 is the same as that of the M61A2, its SQ impact action is patterned in general after that of the M502, except that M506 has no interrupter. The M506 has another detonator in the detonator for strengthening the flash of the point detonator. Because M506 has both time and impact action, it is suitable for firing at either aircraft or ground targets. Its description is given in Ref 52, pp 5-76 to 5-80, but the drawing (Fig 5-51) does not give all the details of mechanism

Fuze, MTSQ M518A1 [or M518 (T286E1)]. This fuze, intended for use in AA cartridges, is essentially fuze M502A1 but with different booster. It is briefly described in Ref 52, pp 5-80 & 5-81 without giving a drawing of its mechanism

Fuze, MTSQ M520A1 (or M520). This fuze intended for use with rotated ammunition caliber 75-mm thru 280-mm, except 175-mm is described in Ref 52, pp 5-81 to 5-83, without

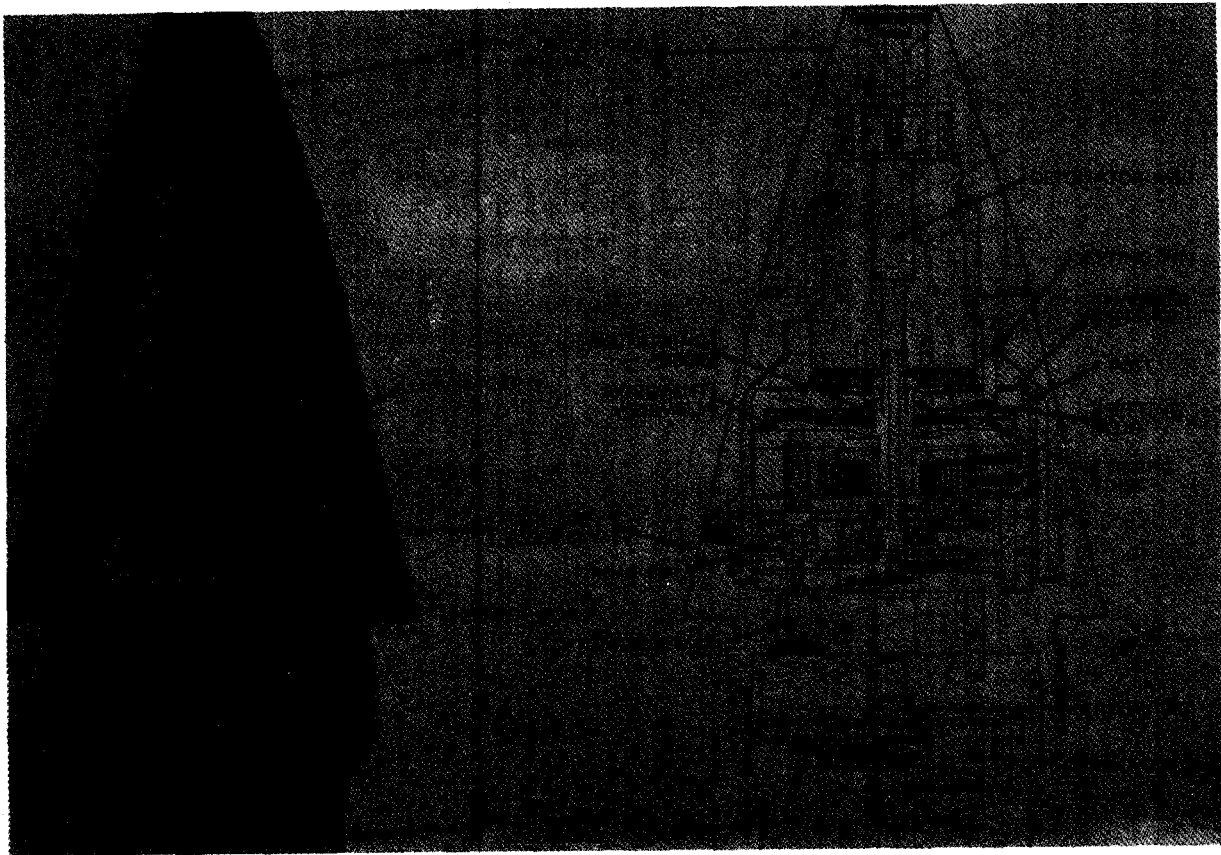

Fig 1-90 FUZE, MTSQ, M548

giving a drawing of its mechanism, but just an external view

Fuze, MTSQ M548. This fuze intended for use with spin-stabilized projectiles, is an improvement over older MTSQ fuzes (such as M501 series) in that it provides a longer timing mechanism (100 seconds) for longer range functioning. The fuze is fully described in Ref 52, pp 5-83 to 5-89 and the drawings include: Fig 5-53 (External and cross section views); Fig 5-54 (Exploded view); Fig 5-55 (Clock movement assembly); and Fig 5-56 (Explosive trains). The main components of fuze M548 are the body assembly (Fig 1-90), point detonating assembly, the lower cap, the movement assembly and safety adapter assembly

This fuze is designed to function either at a set time or upon impact, depending upon

whichever occurs first after arming. The safety adapter arms after traveling a minimum distance of 60 meters from the weapon muzzle

The fuze is assembled in the unarmed position and remains in this condition during transportation and storage. When the fuze is set, the turning of the lower cap rotates the timing disk by means of the setting pin, which is engaged in the upraised lug of the timing disk assembly. All other parts of the mechanism remain in position, since the gear train and escapement components are locked until firing

Upon firing, setback causes the hammer spring to strike the upraised lug of the timing disk, flattening the lug and releasing the disk from the setting pin. The hammer spring returns to its original position as setback ceases. When sufficient centrifugal force has developed, the detents holding

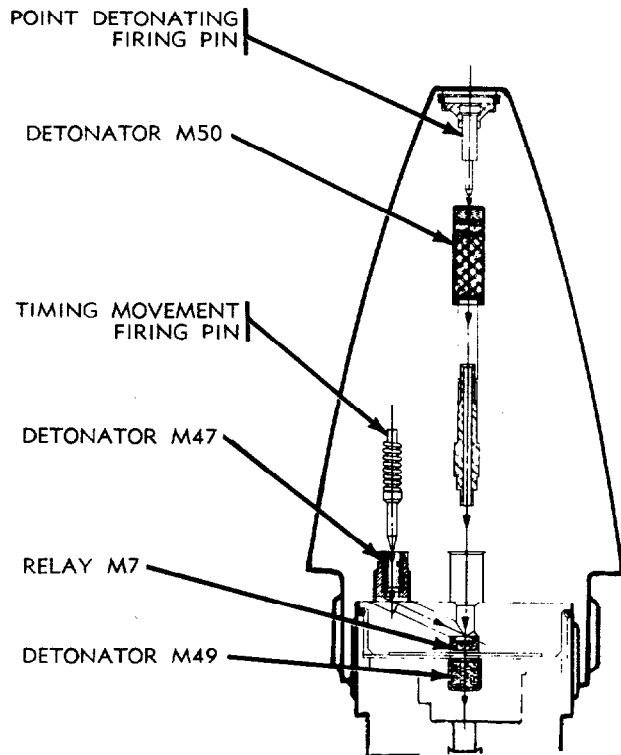

Fig 1-91 FUZE, MTSQ, M548
(Explosive Trains)

the escapement lever of the movement assembly (and the detents holding the rotor of the delayed-arming safety adapter) move outward, leaving the escapement components free to run. Simultaneously, centrifugal force actuates the stop lever arbor, which disengages from the arbor and thus releases the mainspring. As the mainspring drives the movement, the rate of rotation of the arbor and, therefore, of the timing disk is governed by the escapement thru the gear train. When the notch in the rotating timing disk reaches the upright of the firing arm, the firing arm turns, permitting the firing pin safety plate to swing out from under the firing pin flange, and allowing the firing pin to strike detonator M47. Detonator M47 initiates relay M7 which, in turn, initiates flash detonator M49 in the safety adapter (Fig 1-91)

Note: If the fuze is set for superquick action (as shipped), detonator M50 initiates relay M7 upon impact

The safety adapter becomes armed only after the projectile has traveled a minimum of 60 meters (200 feet) from the weapon, depending on the weapon, muzzle velocity and rate of spin. When the projectile is fired centrifugal force withdraws the detents from the rotor which, in the unarmed position, holds the detonator in an out-of-line position to the flash path of the fuze. The rotor gear tooth segment drives the main gear of the delay arming mechanism. The rotor swings into the armed position, in which the flash detonator M49 is aligned with relay M7 in the fuze. It is locked in this position by a lock pin. Initiation of the flash detonator is by relay M7 which is common to both the time expl train and the SQ expl train

Fuze, MTSQ, M564. This fuze intended for use with spin-stabilized projectiles, is an improvement over older MTSQ fuzes (such

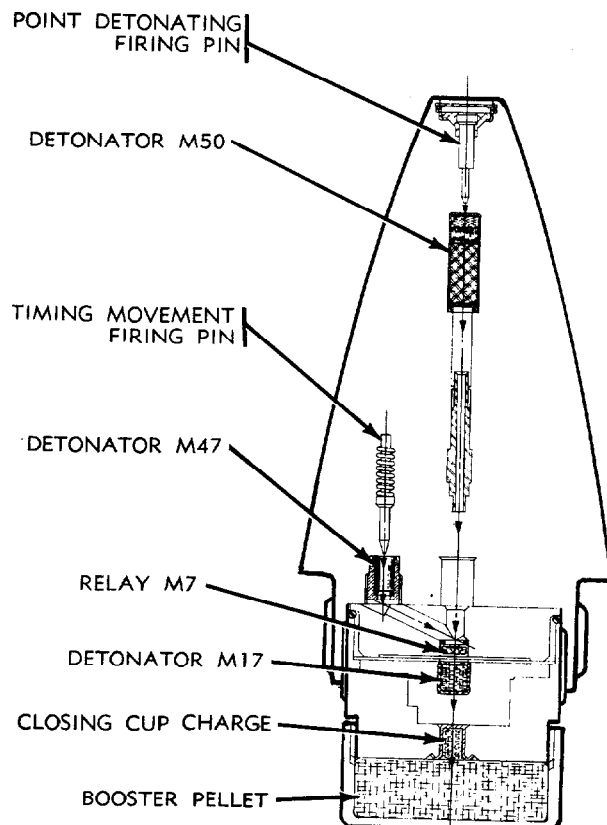

Fig 1-91a FUZE, MTSQ, M564

as M520-series) in that it provides a longer timing mechanism (100 seconds) for longer range functioning. Its description is given in Ref 52, pp 5-89 to 5-93. We are reproducing here its cutaway view, showing explosive train of the fuze (See Fig 1-91a)

Section 5, Part C

d) Base-Detonating (BD) Artillery Fuzes

Following is a description of fuzes located at the base of projectiles. The current BD fuzes are described in the 1967 edition of TM 9-1300-203 (Ref 52, pp 5-102 to 5-108), while fuzes used during WWII are described in Ref 17, pp 138-43 and in Ref 20a, pp 262-71

Fuze, BD, M58 (See Fig 1-92) consists of a brass or steel body (I), containing the firing pin (F) and sleeve assembly (G); a brass holder (C) for detonator (D), and a brass or steel closing cup (A). The cup (A) holds the booster pellet (B), the final charge of the fuze explosive train. There are no boresafety arrangement or external safety devices, the striker being held in the unarmed position prior to firing by a resistance ring (H) which holds the firing pin at the rear of the sleeve and away from the detonator

Functioning: Upon firing, setback action forces the ring (H) over the shoulder of the firing pin and into the groove near the back of the firing pin, locking the pin in a more forward position in the sleeve. During the flight of the projectile, the combined pin and sleeve assembly is held to the rear by its spring. Upon impact, the pin and sleeve assembly move forward against the restraint of the spring and the firing pin strikes the detonator initiating the explosive train. There is no delay element in this fuze.

This fuze was used during and after WWII in the HE shell M63 for 37-mm guns M3A1 & M6. Overall length 2.02 inches; weight 0.30 pounds (Ref 17, p 138 & Ref 20a, pp 262-64)

Fuze, BD M58, Practice for use with target practice cartridge M63Mod1 for 37-mm sub-caliber guns is described in Ref 52, pp 5-102 & 5-103; no drawing given.

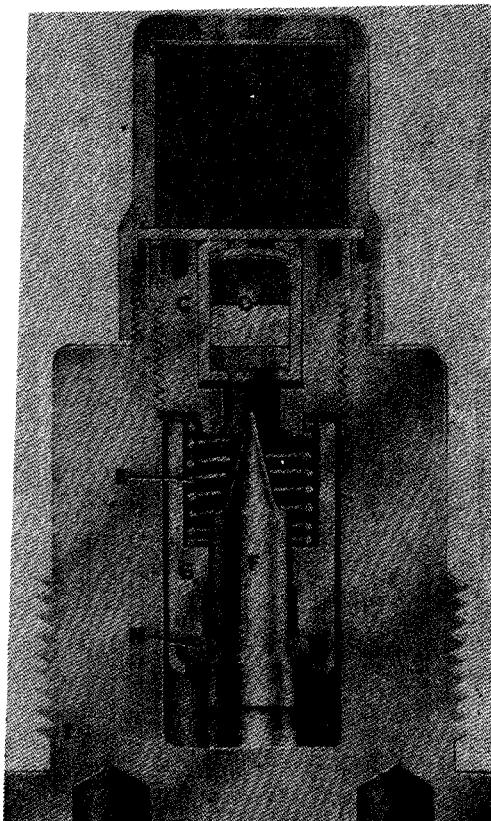

Fig 1-92 FUZE, BD, M58

Fuze, BD M60, formerly used in 155-mm Gun M2 is described in Ref 17, p 143 & Ref 20a, pp 264-66 but not in Ref 52. Drawing is given on p 266 of Ref 20a

Fuze, BD M62A1 for use in medium caliber HEAT (high-explosive antitank) projectiles is described in Ref 17, p 142 & Ref 20a, p 255, but not in Ref 52

Fuze, BD M62A2 is a nondelay type provided for use on HEAT & HEP projectiles. It is described in Ref 52, p 5-103 but no drawing is given

Fuze, BD, M66A2 (and M66A1). Both are delay-action fuzes for use with APC-T (armor-piercing capped-tracer) projectiles, the A2 in 76-mm guns, while A1 in both 75 and

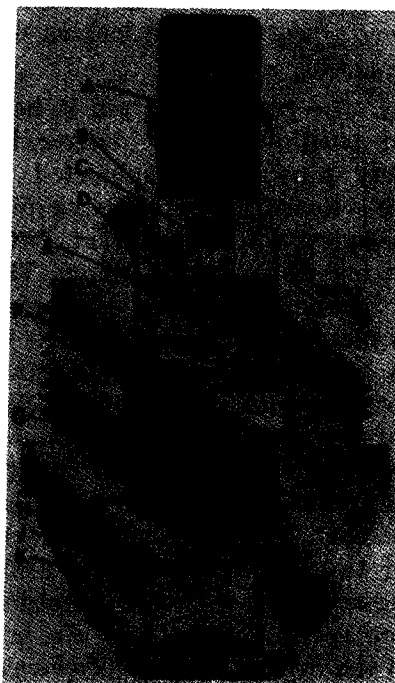

Fig 1-93 FUZE, BD, M66A2

76-mm guns. Both fuzes are of the simple inertia type without boresafety provision and they are essentially the same from the point of view of functioning. Fuze A2, which is represented here in Fig 1-93, is slightly larger than A1 (3.527 inches long & 1.79 diam vs 3.458 and 1.65 inches for M66A1). Both fuzes are made up of three parts: a body assembly (K), a detonator-booster assembly (B) and a primer holder assembly (D). The body assembly contains the firing pin (H) and in a cavity of the boattailed rear portion, a red tracer composition (J) which operates independently of the fuze mechanism. The detonator-booster assembly (B) holds a detonator (C) and a Tetryl booster pellet (A). The primer holder assembly contains Primer No 26 in Fuze M66A1 and Primer No 31 in M66A2, as well as a BkPdr delay pellet (E). A soft steel washer (G) keeps firing pin (H) at rest prior to impact

Functioning. The tracer composition (J) is ignited by the flash of propelling charge and burns thereafter for prescribed time (a minimum of 3 seconds), providing

a visible trace. The firing pin (H) remains at rest upon firing of propnt chge and during the flight of projectile. Upon impact, the set-forward force of the firing pin breaks the soft steel washer (G) and the point of the pin strikes the primer (F). The flash of the primer ignites the BkPdr delay pellet (E). After burning a prescribed time (0.01 sec) the flame reaches the primary charge of detonator (R) and causes it to detonate. The impulse causes detonation of booster (A), and this is followed by explosion of main charge of projectile (Ref 20a, pp 265-68 & Ref 52, pp 5-103 & 5-104)

Fuzes, BD M68A1 and M68. They are provided for use with APC-T (armor-piercing capped with tracer) projectiles in 90-mm weapons. Fuze M68 is similar in construction and operation to M66A1 except that its diam (2.0 inches) is larger and Fuze M68A1 is similar to M66A2 except that its

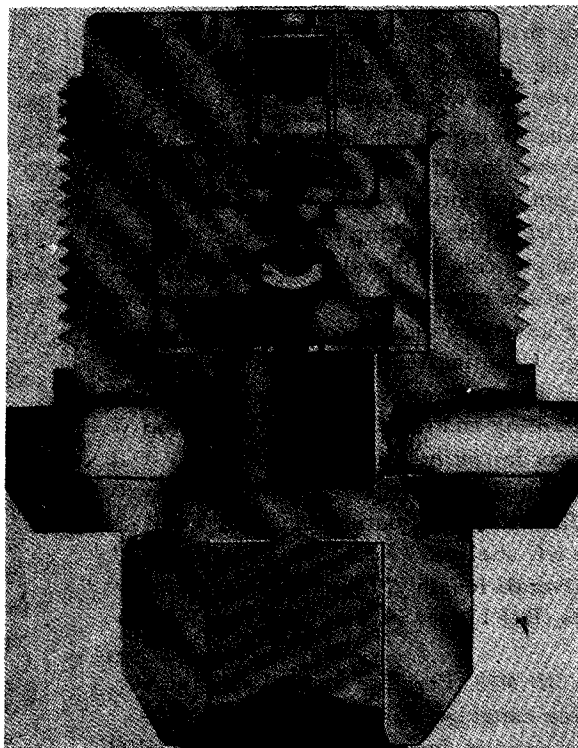

Fig 1-94 FUZE, BD, M72

diam (2.25 inches) is larger. These fuzes are described in Ref 52, pp 5-104 & 5-105, but no drawings are given

Fuze, BD M72 is a delay-action provided for use on 57-mm APC (armor-piercing-capped) projectile M86. It is based on the same principle as the M66A1 and M66, and has a similar firing mechanism as well as the same tracer (C), primer (B) and detonator (A) assemblies (See Fig 1-94). However, the diameter of the body is smaller and the booster pellet is omitted; instead of a booster for the fuze, the shell loading includes a Tetryl pellet at the base end of the main charge. Aside from the shift from booster in the fuze to a pellet in the shell, functioning of M72 is the same as for the M66A1 (Ref 20a, pp 268-70, Fig 151)

Fuze, BD M91A1 is a predecessor of M91A2 and is described in detail in Ref 20a, pp 270-71 and Ref 52, pp 5-106 & 5-107 (See Fig 1-95). It has been used with 75-mm and 105-mm HEAT-T projectiles. It differs from the BD fuze M62A1 only in having a tracer element (T) in its conical end. The tracer has an average burning time of 7.5 seconds. The fuze consists of four parts: a steel head (M), a steel body (C) and a brass booster cup (A). The head holds a rotor-firing pin (K) and inertial plunger (J). The body contains a detonator (H), a slider assembly (E) & spring (G), a Tetryl booster pellet (B) and a booster lead (D). The brass booster cup (A) seals the pellet (B) in its cavity in the fuze body (C) when screwed to the body. Boresafety is provided by the slider assembly (E)

Functioning. The rotor-firing pin (K) is held in the unarmed position in the plunger by spring-held safety pins (L), which release the rotor-firing pin under the action of centrifugal force. The plunger (J) assembly will not arm at 1700 rpm or less. The slider assembly (E) normally is positioned under spring (G) pressure in its recess in the fuze body (C) so that the slider charge (F) of the slider (E) is out of alignment with the other explosive elements. When suf-

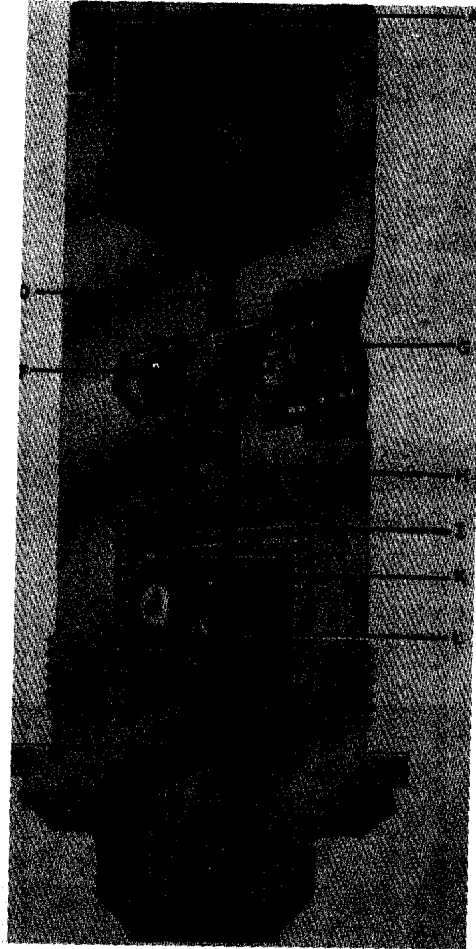

Fig 1-95 FUZE, BD, M91A1

ficient centrifugal force has been set up, the slider overcomes the resistance of the spring (G) and moves outward, bringing the slider charge into alignment. The slider will not arm when the fuze revolves at 2400 rpm or less, but must arm at 3600 rpm. Upon firing and after sufficient rotational force has been created, the firing pin and slider move into the armed position. However, the plunger assembly is held to the rear during the flight of the projectile by the restraining spring (I). Upon impact, the plunger overcomes the resistance of the spring and carries the firing pin (K) against the detonator (H) initiating the action of the explosive train. The booster pellet (B), in

turn, causes detonation of the shell bursting charge. The tracer, which is ignited by propellant gases, creates a luminous trace during the flight of the projectile

Fuze, BD M91A2 is a nondelay fuze used with HEAT-T & HEP (high-explosive, plastic) ammunition. It is similar in construction and functioning to M62A2 (which is not described here because no drawing is available), except that it is provided with a tracer element (Ref 52, p 5-105; no drawing)

Fuze, PIBD M509A1 or M509. This point-initiating, base-detonating fuze was designed for use in fin-stabilized HEAT projectiles. It contains the electric detonator M48 (qv) and the fuze power source is a polarized ceramic disk with piezoelectric characteristics, which is located in the nose of the pro-

jectile. The fuze is described in Ref 52, pp 5-54 & 5-55 and its mechanism is shown in Fig 5-37 of Ref 52. We are not describing it, but prefer to describe its improved version, *Fuze M530A1*

Fuze, PIBD, M530A1 (or M530). This single-action, point-initiating, base-detonating fuze was designed for use in low-velocity HEAT projectiles. It is similar to PIBD M509A1 fuze except for addition of a graze-sensitive mechanism and some other changes which will be indicated below. The fuze consists of a rotor housing (See Fig 1-96) containing a brass rotor (instead of Al in M509 to provide more rotor inertia), an electric detonator M69 (instead of M48 as in M509), a bleeder resistor, sequential leaves and a flat spiral (clock-type) rotor spring (instead of wire helical spring of M509). Forward of the rotor housing is a booster lead cup

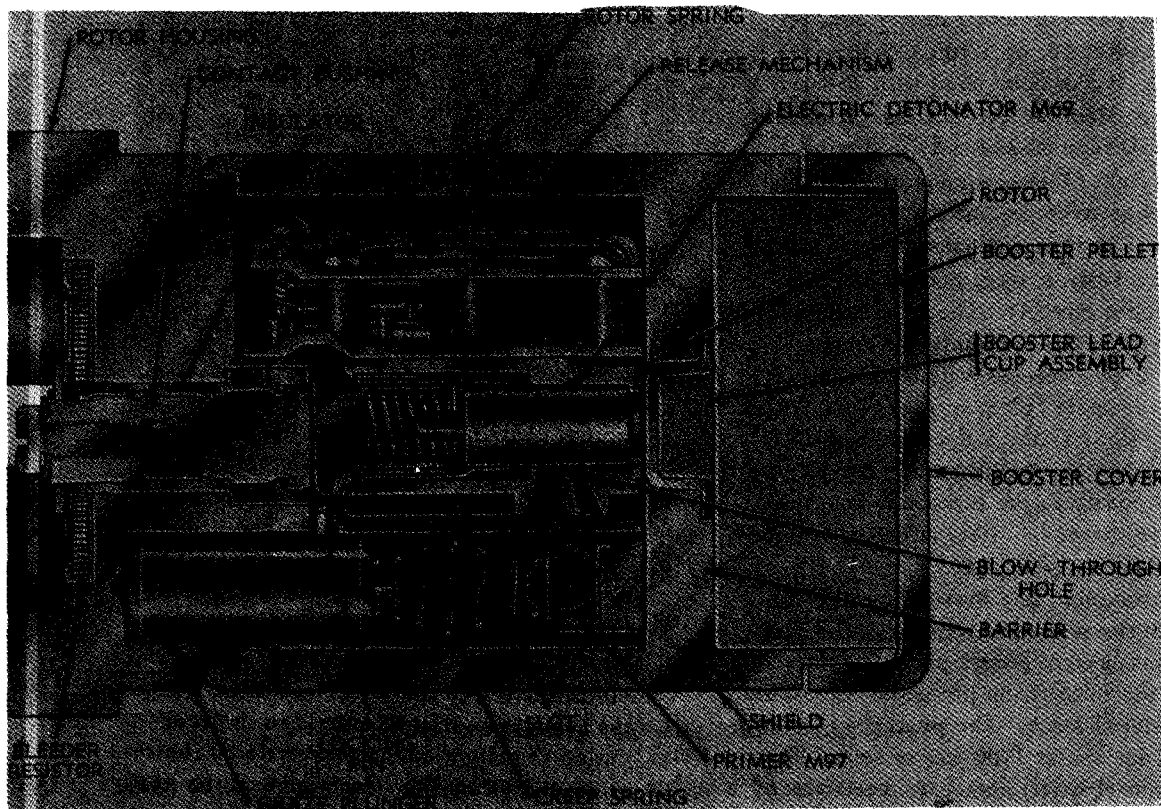

Fig 1-96 FUZE, PIBD, M530A1

assembly and a booster. Electrical contact between the rotor housing and rotor is made thru the contact spring (located in the rotor housing) when the rotor is in an armed position

When the projectile is fired, sustained acceleration creates setback forces which act upon the sequential leaf arming mechanism located in the release mechanism assembly. The leaves are sequentially displaced by setback forces until leaf No 3 is locked in its rear or armed position. The preloaded rotor spring then rotates the rotor 270 degrees (instead of 90° in M509) until the rotor is in the in-line or armed position. A stop pin protruding from the rotor butts against a stop slot in the bearing plate to assure positive alignment of the electric detonator in the inline position. After rotor rotation, the contact wiper, which is secured to the rotor, makes contact with the spring (located in the rotor housing) and completes the electric circuit for arming the fuze. When the projectile strikes the target, the polarized ceramic element (disk) with piezoelectric characteristics, located in the nose of projectile is deformed, and this causes generation of an electric impulse thru electric detonator. Its detonation is transmitted thru booster lead to booster and then to the main charge of projectile. Detonation may also be caused by graze impact. In this case, an inertia-operated firing pin overcomes a creep spring and initiates the stab primer M97, which, in turn, shock initiates the electric detonator M69 (Ref 52, pp 5-55 & 5-56; Fig 5-38 on p 5-56)

Fuze, BD M534A1 has been used with WP-T (White phosphorus with tracer) cartridge M416 in 105-mm cannon M68. Its description is given in Ref 52, p 5-107, but there is no drawing

Fuze, PIBD XM539E4 and Control-Power Supply XM22E2. The fuze described in Ref 52, p 5-57 without giving its drawing, is based on the principle of arming with the axis of rotor perpendicular to the axis of

spin. The fuze contains a detonator for superquick functioning. The electrical power supply is required to produce sufficient electrical energy to function the fuze on either point impact or graze impact with the round. This is accomplished by creating an electrical charge on the piezoelectric element during firing, holding it thruout the flight, and supplying the electrical energy to the fuze upon impact. The charge is collected on the piezoelectric element under setback, bleeding the resultant charge off thru a shorting bar during a portion of peak setback (shorting bar closed) and storing the opposite charge which collects on the piezoelectric element during setback decay (shorting bar open). The piezoelectric element acts as a capacitor to store the charge during the flight of the round to the target. The electric energy is supplied to the fuze by discharging the element thru the impact switch. The switch can be closed by either sufficient deceleration of the round, or by crush-up of the nose of the round. If the electrical charge is lost, nose impact will cause the control-power supply to initiate the fuze. The electrical circuit from the control-power supply is shorted in the fuze at all times except when the rotor is in the ARMED position. The rotor is controlled by two spin detents and a rotor return mechanism. The detents lock the rotor in the UNARMED position until sufficient spin releases them. When round is in flight, the control-power supply is charged with electric energy which is stored. Arming occurs as spin is developed and the detents move outward allowing the rotor to align with the detonator. Crushing of the nose on impact with target or deceleration caused by graze causes an inertia ball switch to close, discharging the stored electrical energy to the fuze

Fuze, BD M578 has been used with cartridge M393A2 in 105-mm cannon M68. It is similar to BD M534A1 except that the shoulder with a threaded hole at the rear of the fuze body has been eliminated and the tracer element inserted in the base of

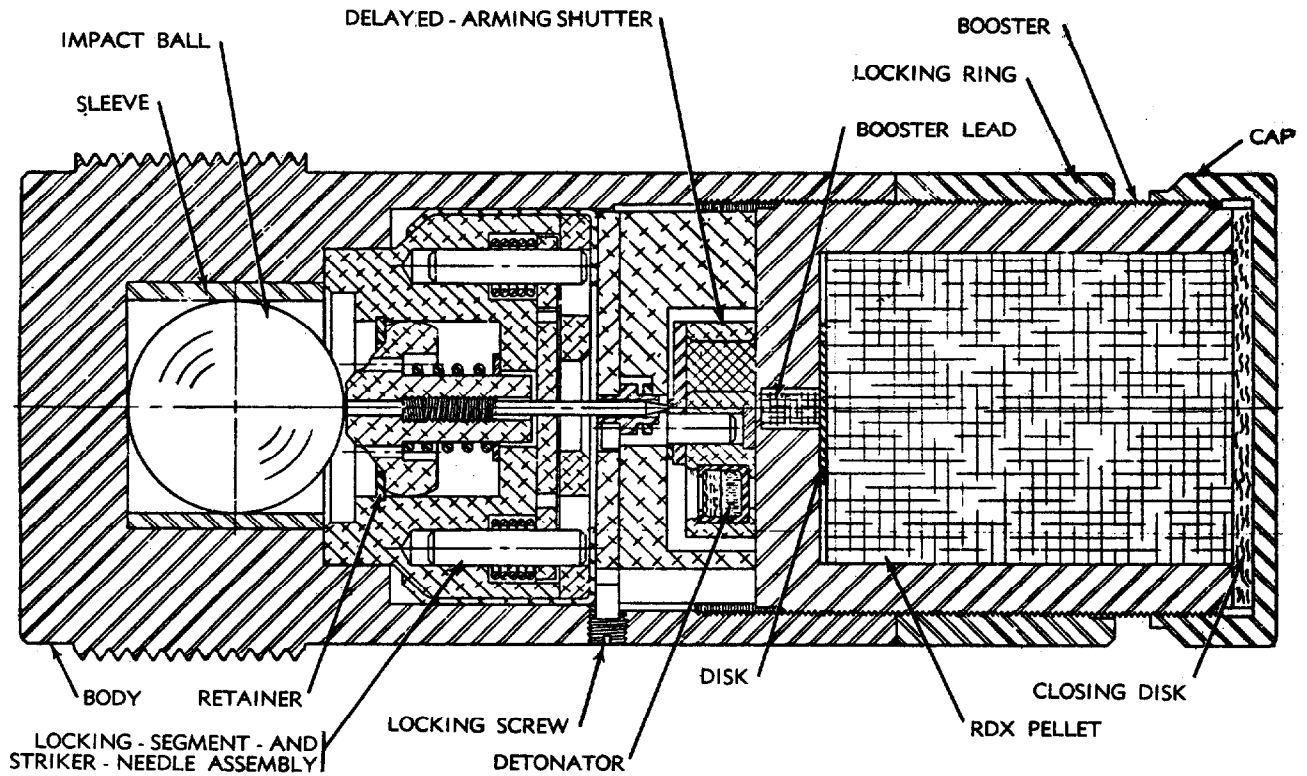

Fig 1-97 FUZE, BD, M578

the projectile. The fuze consists (See Fig 1-97) of an Al body with a base flange, a steel impact ball in a sleeve near the rear of the fuze body, a striker-locking mechanism and a striker needle assembly, a delay arming shutter, a booster lead, a booster contg RDX pellet, a threaded Al sleeve for locking the booster to the fuze body, and a booster cap for retaining RDX pellet within the booster

Functioning. The fuze becomes armed after the locking segment moves into the armed position (this occurs at a rotational speed of 6000 to 8500 rpm) and the delay arming shutter moves into the armed position (this occurs at a rotational speed of 7000 to 8500 rpm). Upon either direct or graze impact, the steel ball moves the striker assembly forward until the striker needle hits the detonator and initiates it. The impulse will be transmitted thru the lead to booster and then to the main charge

of projectile. When the projectile hits armor plate on direct impact, the force imparted to the ball overcomes the force of the creep spring and friction. However, if the projectile impacts at a low angle (graze), the decelerating force may not be sufficient to overcome the force of the creep spring and friction; the fuze then will not function on first impact but may function on subsequent impact (Ref 52, pp 5-107 & 5-108; Fig 5-68)

Section 5, Part C

e) Proximity or VT (Variable Time) Artillery Fuzes

These fuzes, sometimes called "Posit"; "Buck Rogers"; "Special"; "Influence" and "Bonzo" are in effect "automatic time fuzes". Without "setting" or "adjustment"; they detonate the missiles that carry them on approach to the target at the desired point on their trajectories, such as

within 70 ft of the plane or other target. Artillery VT fuzes are essentially a combination of self-powered radio transmitting and receiving units. In flight, the armed fuze broadcasts radio waves. Unlike radar devices, the radio waves are sent continuously and are nondirectional. Those radio fronts which are reflected back from airplane, ground, or water to the moving missile, interact with the transmitted wave. When this interaction of transmitted and reflected waves (resulting in ripples or beats), reaches a predetermined intensity, it trips an electronic switch, which then permits an electric charge stored in the firing capacitor (condenser) to flow thru an electric firing squib.

The VT fuzes can be used only in deep-cavity projectiles (booster cavity is 2.75 inches deeper than for PD, MT and TSQ fuze booster cavities) without the supplementary bursting charge

It seems that VT fuzes for bombs were invented by the Germans before WWII and some of them are described below under "Bomb Fuzes". British also started to work on VT fuzes before WWII and then, in August 1940 work started in US. By 1943, the US Navy started to use them against Japanese planes, especially the "Kamikadze" (suicide) planes. In 1944 US Army used them successfully at the battle of Ardennes

About 20 million such fuzes were used by US Forces for artillery shells and about 2 million in bombs and rockets

Description and Functioning of a Typical VT Fuze. Although the several models differ from each other in details, the following is a general description of such fuzes. The VT fuze described in Ref 20a, pp 255-62 and shown in Fig 147, consists of a plastic nose (C) molded to a steel base (F). A perforated nose cap may or may not be molded inside the nose tip. A special booster (N) contg a boresafe element (M) extends below the base of the fuze. Some lots of fuzes are protected by a heavy outside coating of wax which must not be removed at any time. In flight, the wax covering on



Fig 1-98 TYPICAL VT ARTILLERY FUZE

the fuze normally spins off, occasionally producing a visible trail. This trail disappears after 3-4 seconds time of flight. If wax is present, paper or cellophane caps

protecting the tip of the fuze nose must be removed prior to firing. A radio transmitter and receiver (E) is housed within the plastic nose of the fuze. A wet battery of the reserve type is used to supply electric current. It consists of a number of cells (G) and a glass vial (H) containing the electrolyte.

A supporting device (I) prevents the vial from moving to the rear until a setback force of some duration acting upon the glass vial forces the leaves of the device to open. The vial drops inside the supporting device and is broken. The electrolyte is released and is forced by centrifugal action into the plates of the battery. Current is generated, the radio tubes (D) light up, and the transmitter broadcasts a continuous wave. To provide delayed arming, the firing capacitor (condenser) is charged by the battery thru a high resistance circuit. The high resistance in the circuit prevents a charge of sufficient energy to fire the electric squib from collecting on the capacitor (condenser) for a half second or so after the battery is activated. This mercury switch or "unshorter" (J) consists of an electrical contact chamber, a porous metal cup, and a sump. This mercury switch shorts out the electric squib until the projectile has rotated at a high rate for a predetermined length of time. Centrifugal action forces the mercury out of the electrical contact chamber thru the porous cup into the sump. In this way, the "short" between the central contact and the outside shell is removed, enabling the charge in the firing capacitor (condenser) to be discharged thru the squib when the fuze is "triggered" by a target, instead of harmlessly being shunted past the squib thru the mercury. The time of unshorting is determined by the porosity of the metal cup and the centrifugal force developed. VT fuzes incorporate either a self-destruction switch (K) for AA firing or a centrifugal switch for terrestrial firing. These consist of a flexible metal reed in a plastic plug, inserted in an insulated metal cylinder, and are assembled off the axis of the fuze. They keep the firing capacitor (condenser) shorted when the projectile is

at rest so that the firing capacitor (condenser) cannot accumulate a charge. Centrifugal force bends the reed spring, opening the switch, when the projectile is spinning at a rate higher than a preset value. Used as a self-destruction switch, the setting is adjusted so that spring action closes the switch, completing a circuit between the firing capacitor (condenser) and electric squib (L), when the rate of spin of the projectile decreases to the preset value. An impact element is contained in the rear fitting device of some VT fuzes for howitzer shell. The Mk 6 rear fitting safety device (O) does not contain an impact element, but the Mk 10 (not shown) does contain one.

Arming is delayed by the series of safety devices for at least 2 seconds after firing for the T76E6 and T80E6 models of fuzes, for at least 0.5 second for the M92 and M93 fuzes, and for at least 5 seconds for all other models of the T76 and T80 fuzes, including the M96 and M97. The exact time or arming depends upon the caliber and propelling charge used, and also may vary from lot to lot. The VT fuzes are completely boresafe and muzzle safe. Height of burst above the terrain of terrestrial VT fuzes varies with large changes in angle of fall, becoming lower as the angle of fall becomes steeper. These fuzes are designed to give optimum burst over average soil; however, the average height of burst is slightly higher over moist soil than over dry soil and 50% higher over marshy or very wet terrain than over dry land. Light tree foliage and vegetation do not affect the height of burst materially, but dense tree foliage and thick vegetation will increase the height of burst above the ground. This effect is decreased at a steep angle of fall, in which case most shell will burst below treetop level. The dispersion in height of burst decreases as the time of flight is increased.

VT fuzes may also function under the influence of nearby bursts or fragments.

Several modifications of each standard type of VT fuze have been made to incorporate various improvements in the elec-

trical portion of the fuze, but some of these improvements have little significance in over-all fuze performance

The types of fuzes listed in Ref 20a, pp 258-59 are evidently obsolete. Unfortunately no drawings of mechanisms of recent VT fuzes are given in Ref 52, but just external views

The following VT fuzes are listed in Ref 52:

Fuzes, Proximity, M504A2, M504A1 (T75E7) and M504 (T75E6). Long contour fuzes for use with deep-cavity HE projectile M73 in AA cannons (pp 5-116 & 5-117)

Fuzes, Proximity, M513 (T226) and M513B1 (T226B1). Early models of the adjustable, delayed-arming type for use in 75-mm to 105-mm field artillery projectiles, including terrestrial targets (pp 5-117 & 5-118)

Fuzes, Proximity, M513A1 (T226E2) and M513A2 (T226E3). Later models of M513 series and used in the same projectiles as above (pp 5-118 & 5-119)

Fuzes, Proximity, M514 (T227) and M514B1 (T227B1). Early models of the adjustable delayed-arming type for use in 155-mm and larger caliber HE projectiles against terrestrial objects. They are not fully effective against airborne targets (pp 5-119 & 5-120)

Fuze, Proximity, M514A1 (T227E2). It is a later model of M514 series and used in the same type and caliber projectiles (pp 5-120 & 5-121)

Fuze, Proximity, M515 (T225). It is designed to be used with 90-mm deep-cavity HE projectiles against airborne targets (pp 5-121 & 5-122)

Fuzes, Proximity, M516A1 (T73E10), M516B2 (T73E14), M516B1 (T73E13) and M516 (T73E12). These fuzes are used in 75-mm HE cartridges against airborne targets (pp 5-122 & 5-123)

Fuze, Proximity, M517 (T178E3). It is used in 81-mm HE cartridge M362 series against terrestrial and waterborne targets (pp 5-123 to 5-125)

Fuze, Proximity, Mortar, M532. It is designed for use in HE cartridges M374 & M362 series; can be converted to point-detonating (impact) action fuze (pp 5-125 & 5-126)

Section 5, Part C

f) Recoilless Rifle Projectile Fuzes

These fuzes are similar to those used in artillery projectiles and the following types are described in TM 9-1300-204 (1959) (Ref 40):

BD Fuze, M62A1 - for use in 75-mm and 106-mm projectiles (pp 31-32)

BD Fuze, M91A1 - same use as above (pp 32-34)

Dummy Fuzes M73, M126 & M89 (p 34)

MTSQ Fuze, M500A1 (or M500) - use not indicated (pp 34-35)

PI Fuze, M90A1 - for use in 57-mm HEAT projectiles (pp 35-36)

PIBD Fuze, M509 - for use in HEAT projs of various calibers (pp 36-37)

PD Fuze, M48A3, 0.05-sec Delay - for use in 75-mm smoke projs (p 37)

PD Fuze, M51A5 (or M51A4), 0.05-sec Delay - use not indicated (pp 37-39)

PD Fuze, M57 - for use in 75-mm smoke projs (p 39)

PD Fuze, M89 - for use in 57-mm projs (p 39)

PD Fuzes, M503A2, M503A1 or M503 - for use with 57-mm projectiles (pp 40-41)

Following recoilless rifle projectile fuzes are described in TM 9-1300-203 (1967) (Ref 52):

BD Fuze, M62A2 (p 5-103), shown here on Fig 1-93

BD Fuze, M91A1 (p 5-105), shown here on Fig 1-95

MTSQ Fuze, M500 (p 5-71), not described here

PD Fuze, M48 (p 5-15), not described here

PD Fuze, M51A1 (p 5-16), shown here on Fig 1-74

PD Fuze, M57 (p 5-24), not described here

PD Fuze, M503A1 (p 5-28), shown here on Fig 1-85

PIBD Fuze, M509 (p 5-54), not described here

Locations of some of these fuzes in recoilless rifle projectiles are shown on Figs 45, 46, 47, 48 & 49 in Section 3, Part D

Types and calibers of projectiles used in recoilless rifles are listed in Section 4, Part B, item b)

Section 5, Part C

g) Mortar Projectile Fuzes

These fuzes are similar to those used in other artillery projectiles and the following types are described in TM 9-1300-205 (1960) (Ref 41) and in TM 9-1300-203 (1967) (Ref 52):

MTSQ Fuzes, M500 Series (p 48 of Ref 41 & p 5-71 of Ref 52)

MTSQ Fuzes, M501 Series (p 50 of Ref 41 & p 5-74 of Ref 52)

MTSQ Fuze, M520 (p 51 of Ref 41 & p 5-81 of Ref 52)

PD Fuze, M8 (p 52 of Ref 41 & p 5-12 of Ref 52)

PD Fuze, M9 (p 55 of Ref 41 & p 5-15 of Ref 52)

PD Fuzes, M51 Series (0.05 Sec Delay) (p 56 of Ref 41 & p 5-16 of Ref 52)

PD Fuzes, M52 Series (p 58 of Ref 41 & p 5-19 of Ref 52)

PD Fuze, M53A1 (p 58 of Ref 41 & p 5-20 of Ref 52)

PD Fuzes, M82 Series (p 63 of Ref 41 & p 5-27 of Ref 52)

PD Fuze, M519 (T319), (p 63 of Ref 41 & p 5-31 of Ref 52)

Pd Fuze, M521 (T247), (p 63 of Ref 41 & p 5-32 of Ref 52)

PD Fuzes, M524 Series (p 64 of Ref 41 & 5-33 of Ref 52)

PD Fuzes, M525 Series (p 64 of Ref 41 & p 5-37 of Ref 52)

PD Fuzes, M526 Series (p 65 of Ref 41 & p 5-42 of Ref 52)

PD Fuzes, M527 Series (p 66 of Ref 41 & p 5-43 of Ref 52)

PD Fuze, M535(T177E3), 0.05-Sec Delay (p 66 of Ref 41 & p 5-44 of Ref 52)

Proximity Fuzes, M513 Series (p 78 of Ref 41 & p 5-117 of Ref 52)

Proximity Fuze, M517 (p 80 of Ref 41 & p 5-123 of Ref 52)

Location of some of these fuzes in 60-mm, 81-mm, and 4.2-inch mortars are shown on Figs 59, 61, 63 & 64 in Section 3, Part D

Types and calibers of mortar projectiles are listed in Section 4, Part B, item c)

Section 5, Part C**h) Foreign Artillery Fuzes of WWII**

1) British. No information is available on fuzes for projectiles used in cannons, howitzers, mortars and recoilless rifle. Fuzes used in rockets are described in confidential TM 9-1985-1(1953) (Ref 26, pp 351 to 372)

2) French. No information is available

3) German. A detailed description of artillery fuzes (Gessosszünder) is given in TM 9-1985-3 (1953), pp 547-608 (listed here as Ref 27b) and this report and some other sources were used in compiling PATR 2510 (1958) (listed here as Ref 35), where a fairly complete description is given under the following titles:

Projectile Fuzes:

Point Detonating (AZ), pp Ger 56 to 62, with 35 figs

Base Detonating (BdZ), pp Ger 62 to 64, with 13 figs

Self-Destroying Fuze, pp Ger 174 & Ger 175, with one fig

4) Italian Artillery Fuzes. The following types are described in Ref 29, pp 133-54:

Nose Percussion Fuze ("spoletta percussione"), of which M10 and M17 were used in most HE projectiles (pp 133-34)

Percussion Nose Fuze for 65/17 HE proj (pp 134-35)

Percussion Nose Fuzes M10 (Guerritore) PC and M (Guerritore) MEGC (pp 135-36)

Percussion Nose Fuze I.M35 for 75 to 210-mm projs (pp 136-37)

Percussion Nose Fuzes I.M38 and I.M32/38 for small and medium caliber projs (p 137)

Percussion Nose Fuze M40 with Detonator M40-Ordinary and Instantaneous for 75 to 100-mm projs (p 138)

Percussion Nose Fuze for 37/40 AP projs (p 139)

Percussion Nose Fuze M39 for 37/32 HE proj (p 140)

Percussion Nose Fuzes M16 (OK 2S912) for 120 and 380-mm projs (p 141)

Percussion Nose Fuze O.BO 34/37 and O.BO 34/40 (p 142)

Percussion Nose Fuze for 37/54 HE Shell (p 143)

Nose Time Fuzes M900/14 and M900/34 for HE projs used in field guns (pp 144-45)

Nose Time Fuze OT32 for 102/35 AA proj (p 145)

Time and Percussion Nose Fuze ADE M99; use unknown (p 146)

Nose Time Fuze M06/17 and Time and Percussion Nose Fuze ADE M06 for shrapnel projs (p 147)

Time and Percussion Nose Fuze ADE M12 for 100-mm HE and shrapnel projs (p 148)

Nose Time Fuze M36 and Nose Time and Percussion Nose Fuze ADE M36 for 75, 100 & 149-mm HE projs and 100-mm shrapnel (pp 148-49)

Nose Fuze Time and Percussion ADE M32 for 100-mm HE proj (p 150)

Nose Time Fuze OT33 for 102/35 AA proj (p 151)

Mechanical Time Nose Fuze M36 for 75/46-mm HE proj (pp 152-53)

Base Fuze for 47/32 AP proj (p 153)

Base Fuze for 100/17 Hollow-Charge projs (pp 153-54)

5) Japanese Artillery Fuzes. The following types are listed in Ref 28b, pp 391-426 & 518-43:

Army Projectile Nose Fuzes:

Type 93, Type 100, Type 2 and Type 2 (Modified) Small Instantaneous Fuzes for 20 & 37-mm AA projs (pp 391-94)

Type 4 Super-Detonating Fuze for 20-mm HE projs (p 395)

Ho 301 Impact Fuze for 40-mm projs (p 396)

Type 88 Small Instantaneous for 50-mm grenade discharger (p 397)

Type 88 Short Delay (Gun and Howitzer Mortar) Fuze for 57-mm to 150-mm projs (p 398-99)

Type 88 Instantaneous (Gun and Howitzer Mortar) Fuze for 47-mm to 150-mm projs (pp 399-400)

Types 90, 93 and 100 Instantaneous-Short-Delay Fuzes for 81, 90 & 150-mm projs (pp 401-404)

Finned Bangalore Torpedo Fuze (p 404-405)

Type 98 Interior Fuze for 32-cm mortar proj (pp 405-406)

Type 89 Small Time Fuze for 70-mm mortar & howitzer projs (p 406-407)

Type 89 Powder Time Fuze for 75 & 105-mm AA projs (pp 408-409)

Auxiliary Detonating Fuze for use in conjunction with Type 89 and other fuzes (pp 409-10)

Type 3rd-Yr Combination Powder Time and Impact Fuze for 75-mm shrapnel proj (pp 410-11)

Type 5th-Yr Combination Powder Time and Impact Fuze for 75 & 150-mm shrapnel projs (pp 411-12)

Type 100 Mechanical Time and Impact Fuze for 88 & 105-mm AA projs (pp 412-13)

Type 2 Combination Powder and Impact Fuze for 75 & 105-mm AA projs (pp 414-15)

Japanese Army Projectile Base-Detonating Fuzes:

Type 94 Small-Delay Fuze for 37-mm T & A/T projs (pp 415-16)

Type 92 Small Short-Delay Fuze for 57-mm Tank projs (pp 416-17)

Small Mk2 Fuze for 47-mm A/T projs (pp 417-18)

Small Mk1 Fuze for 37-mm AP projs (p 419)

Medium Mk1 Fuze for 75-mm AP & HE projs (p 420)

Type 88 Small (Howitzer-Mortar) Fuze for 120 & 150-mm projs (pp 421-22)

Type 88 Small (Gun) Fuze for 150-mm projs (p 422)

Type 95 Large Mk2Mod1 Fuze for 30-cm projs (pp 423-24)

Type 95 Medium Fuze for 15-cm AP & HE projs (pp 425-26)

Japanese Navy Projectile Nose Fuzes:

20-mm Model 1, Model 2 and Model 3, One-Piece Impact Fuzes (pp 518-19)

20-mm Two-Piece Fuze (p 520)

25-mm Model 1 and Model 4 Fuzes (p 521-22)

30mm Fuze for AC Cannon (p 523)

Type 1 Short-Delay Impact Fuze for 8-cm AP projs (p 524)

Type 88 and Type 8 Modification Fuzes for 12-cm to 20-cm projs (pp 525-26)

Type 88 Model 2 Fuze for 12-cm to 20-cm projs (pp 526-27)

Type 88 Model 4 Instantaneous Fuze for 12-cm & 20-cm projs (pp 528-29)

Type 4 Fuze for 20-cm Rocket (pp 529-30)

Type 5th-Yr Fuze for 8, 12 & 14-cm projs (p 530)

40-mm Powder Time for 40-mm AA projs (pp 530-31)

Type 3 Aerial-Burst Impact Mortar Fuze (pp 532-33)

30-Second Powder Time Fuze for 12-cm illuminating projs (pp 533-34)

Type 91 Mechanical Time Fuze for 12-cm to 15.5-cm illuminating projs (pp 534-36)

Type O Mechanical Time Fuze for 20-cm projs (p 537)

Type 98 Mechanical Time Fuze for 10-cm projs (p 538)

Japanese Navy Projectile Base Fuzes:
40-mm Fuze for AP & HE projs (p 539)

5-cm Fuze for HE projs (p 540)

Type 3rd-Yr Mk1 Impact Fuze for 12-cm projs (p 541)

Type 13th-Yr Mk1Mod1 Impact Fuze for 14 & 15-cm projs (p 542)

Type 13th-Yr Mk4Mod1 Fuze for 20 and 36-cm projs (p 543)

6) Russian Artillery Fuzes

Information given in the books of Blinov (Ref 19) and by the late Dr M.M. Kostevich [private communication, Buenos Aires (1954)] was incorporated in our PATR 2145 (1955) (Ref 31)

Briefly, Russian artillery fuzes may be subdivided into:

a) *Vzryvateli* (Exploders or Disruptive Fuzes). They act by detonation (and not

by ignition) and may be considered comparable to US "detonating fuzes"

b) *Snaryadnyye Trubki* (Projectile Tubes). They contain ignition charges only and are used to ignite the expelling charges. These fuzes correspond to US "igniting fuzes"

Each type can be subdivided accordg to location in the projectile into *golovnoy* (point detonating) and *donnyi* (base detonating)

Division accordg to action (function is: *udarnyi* (impact), *distantionnyi* ("distance", which corresponds to US "time"), *mekhanicheskii* (mechanical) and *dvoynogo deystviya* ("double-action" which includes time and impact action)

A table listing some Russian artillery fuzes used during WWII is given in Ref 31, pp Rus 7 & Rus 8

Rus artillery fuzes are also described in confidential TM 30-240 (1953) (our Ref 24) and ORDI 7-102 (1954) (Our Ref 30a)

Section 5, Part D

Fuzes for Use in Items Other Than Artillery Ammunition or Aircraft Bombs

a) Fuzes for Demolition Items

A brief description of demolition explosives, etc is given in Ref 48, pp D56 to D62. Bangalore Torpedo and Bangalore Snake are described in Ref 44, pp B16 & B17. A more complete description of demolition items is given in FM5-25 (1967) listed here as Ref 53

Following is an example of fuzes used in demolition items:

Bullet Impace Fuze, MIA1 for Demolition Snake M3 consists of a body (which contains a detonator and two shaped-charge boosters), a target plate of 3/8-inch thick steel and a spring mounted on three studs. The target plate bears on a firing pin which is restrained by a shear pin and safety fork. The fork must be removed before the fuze can be operated. In placing the fuze, care must be exercised to have the semicircular end up, since the effect of the two shaped boosters is directly downward, perpendicular to the two flat edges. The fuze is described in Ref 30c, pp 126, 128, 131 & 132; and in Ref 46, pp 99, 100, 105 & 106, but not listed in Ref 53

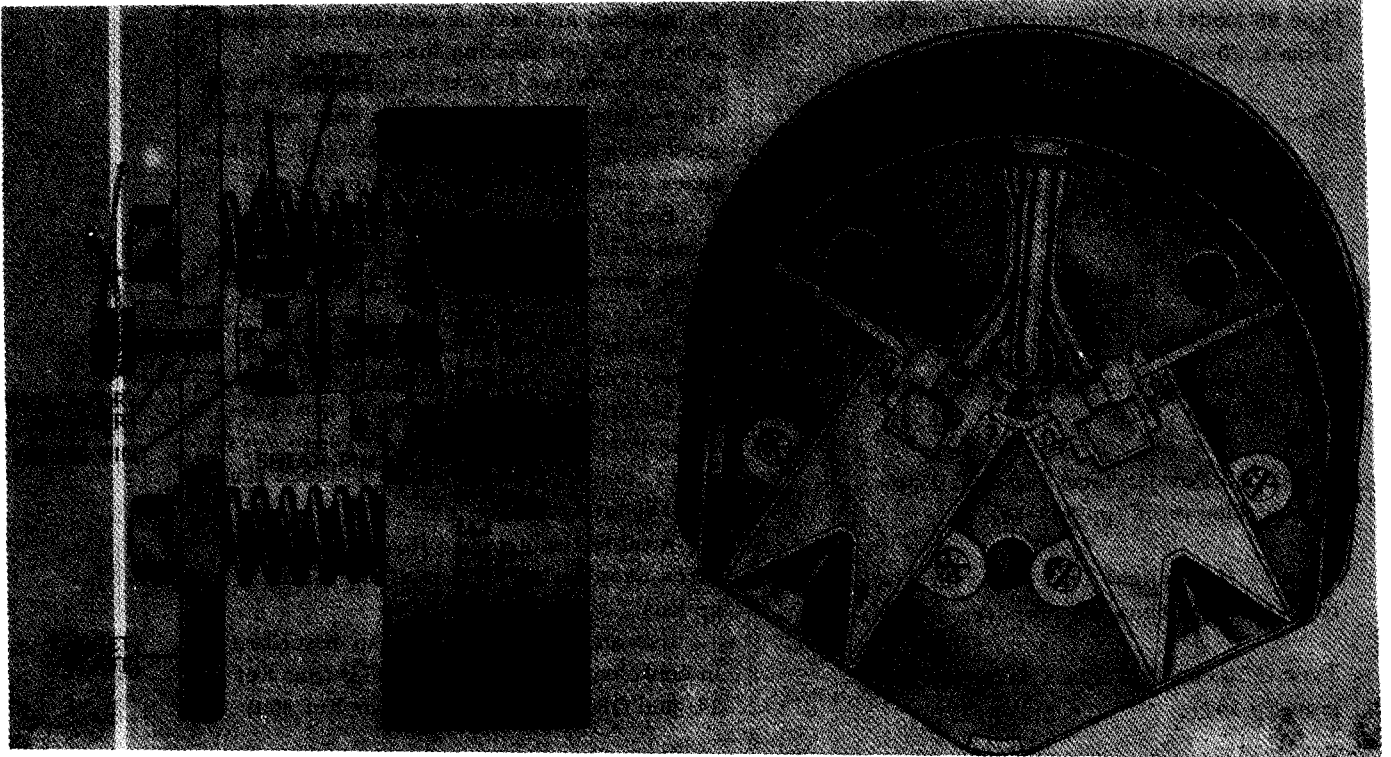

Fig 1-99a BULLET IMPACT FUZE, M1A1 FOR DEMOLITION SNAKE M3

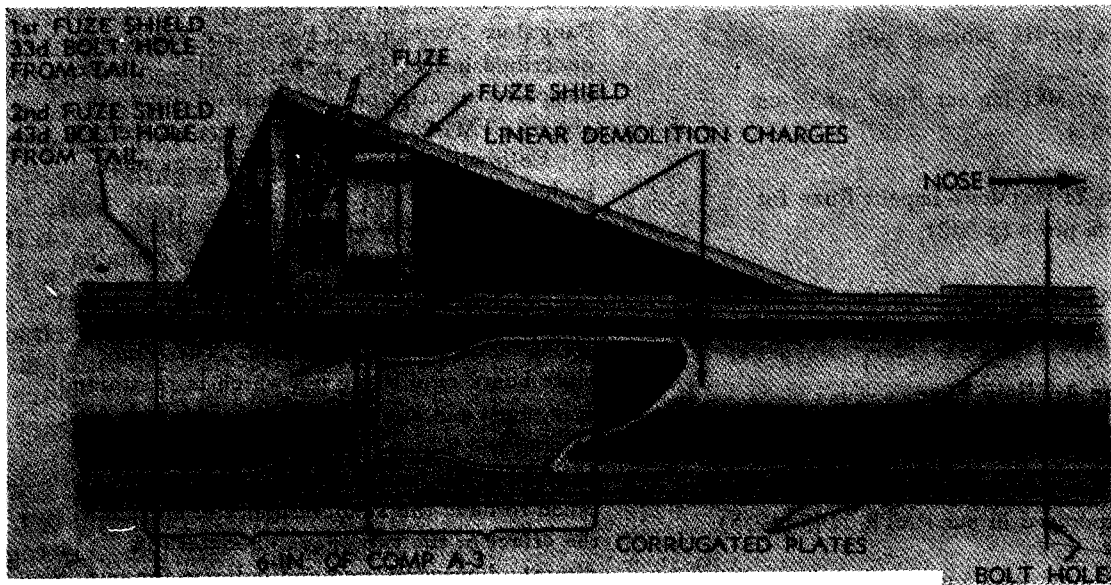

Fig 1-99b LONGITUDINAL SECTION OF PROJECTED CHARGE M3A1 AT FUZE M1A1

Fig 1-99a given here represents cutaway and rear views of fuze, while Fig 1-99b shows its attachment to the demolition charge M3A1. The shield shown on Fig 1-100 serves as a bracket for mounting the fuze and protects it from premature detonation

Fuze M1A1 can also be used with "bangalore torpedos" which are described in vol 2 of Encycl, p B16-R (Ref 44)

Section 5, Part D

b) Fuzes for Hand- and Rifle Grenades

A brief description of current hand and rifle grenades is given in Section 4, Part B, item d), where Figs 20a, 20b, 20c, 20d & 20e are shown

Current fuzes for grenades are described in TM 9-1330-200 (1966), pp 2-4 to 2-7 & 2-13. They include:

Hand Grenade Fuze, M215, shown on Fig 1-100, was developed for use with hand grenade M26A2 (shown on Fig 1-20c in Section 4, Part B). Its cylindrical body,

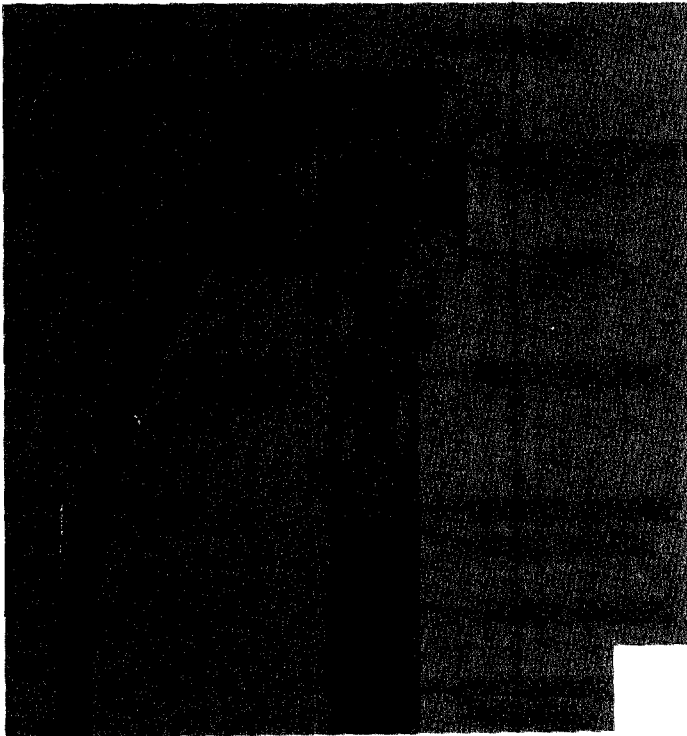

Fig 1-100 HAND GRENADE FUZE, M215

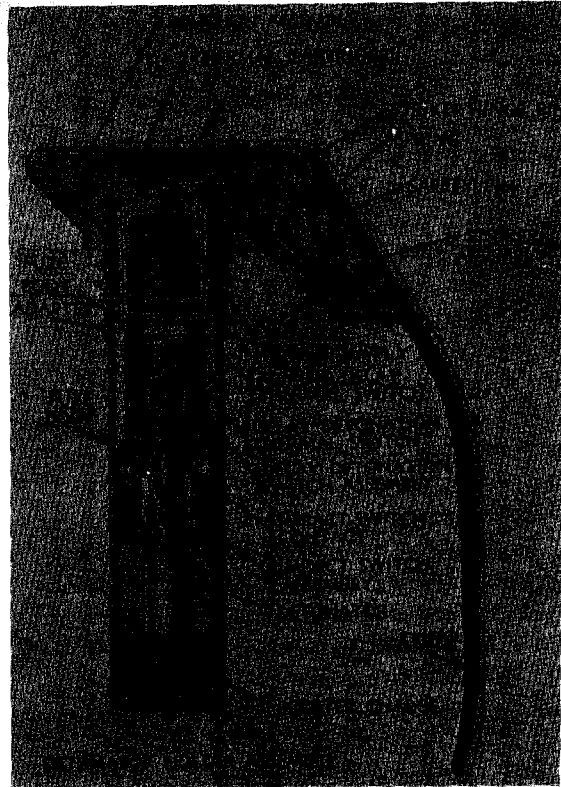

Fig 1-101 HAND GRENADE FUZE, M217

hermetically sealed, contains primer M42, delay column and detonator assembly. The fuze is equipped with a safety pin, a pull ring and a striker assembly. Its action is similar to that of fuze M217, which eventually replaced M215 in the grenade M26A2 (Ref 51b, pp 2-4 & 2-5)

Hand Grenade Fuze, M217, shown on Fig 1-101, was developed to replace fuze M215 in fragmentation hand grenade M26A2 (shown on Fig 1-20c in Section 4, Part B). The fuze is an electric impact functioning type with an overriding delay-function feature. The major components of the fuze are the body (cylindrical steel case, 2.7 inches in length and ca 0.5 inches in diameter), the bouchon assembly and the booster (RDX pellet). The fuze body contains a thermal power supply, a thermal-arming disc, an arming delay-thermal switch, a delay detonation thermal switch, a delay detonation switch assembly, an impact switch contact, an impact switch assembly

and an electric detonator. The bouchon assembly consists of a body, a pull ring, a safety (cutter) pin, a striker, a hinge pin, a striker spring and a lever. The fuze body assembly is hermetically sealed. Upon releasing the lever, the striker assembly throws off the lever (by the action of the spring) and hits the percussion primer M42G. The primer initiates the thermal power supply which causes the fuze to arm within 1 to 2 seconds. After this the grenade will function either on impact or after delay 3 to 7 seconds. If the fuze fails to function, after release of the lever, it will become dud within 30 seconds (Ref 51b, pp 2-6 to 2-9)

Hand Grenade Fuze, M201A1, shown on Fig 1-102, was developed for use in some chemical hand grenades, such as M6, M6 series, M7 series, AN-M8, AN-M14 & M18. It is "delay igniting" type. Its cylindrical body contains primer, delay element and ignition mixture. As issued, the fuze is cocked and restrained from functioning by a safety pin. When the safety pin is withdrawn from the grenade the following sequence of function takes place: The striker, driven by its spring, forces the safety lever out of its path and throws it free of the grenade. This releases the striker making it strike the percussion primer. The resulting spit of flame

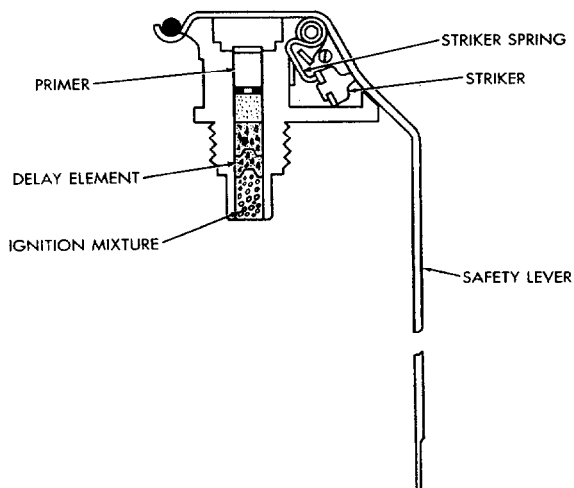

Fig 1-102 HAND GRENADE FUZE
M201A1

ignites the delay element. After burning for 1-2 secs, the ignition mixture of fuze is ignited. This, in turn, ignites the starter mixture in the grenade and finally the grenade filling. The resulting pressure blows off the tape covering emission holes in the body of the fuze, allowing the gases to escape in atmosphere (Ref 51b, p 2-13)

Section 5, Part D

c) Fuzes for Land Mines

A definition of land mines is given under Mine in Glossary given in Section 2, Part A, while their description is given in Refs 32 & 32b

A land mine is intended for placement on the ground or beneath its surface and is designed to destroy or damage vehicles such as tanks ["antitank (A/T) landmines"], or to wound or kill the personnel ["anti-personnel (A/P) landmines"]

Mines contg expl charges are called "service" mines, and those with inert filling "inert" or "practice mines". There are also land mines known as "booby traps" (See Ref 44, p B242-R and FM 5-31)

As an example of fuzes for A/P mines may be cited the "integral fuze" used in A/P Mine NM, M14. It is described in Ref 32, p 241 and Ref 32b, p 39 (See Fig 1-103) This type of mine is known as "blast mine". Its body is plastic, diameter of the case is 2.25 inches, and height 1.5 inches

The mine is buried underground, near the surface and when somebody steps on pressure plate, the firing pin detonates initiating charge of the fuze primer and the shock is transmitted to Tetryl charge of the mine

Another type of fuze is M6A1 and it is designed for use in Bounding Type Mine A/P, M2A4. It is described in Ref 32, p 239 and the same fuze with inerted primer is described in Ref 32b, p 53. The fuze is of the "firing device" type. It is placed into a long column attached at the bottom to propelling charge (See Fig 1-104). It can be initiated either by pressure on any of its prongs or pull of a trip wire attached to the release pin ring. The mine projects,

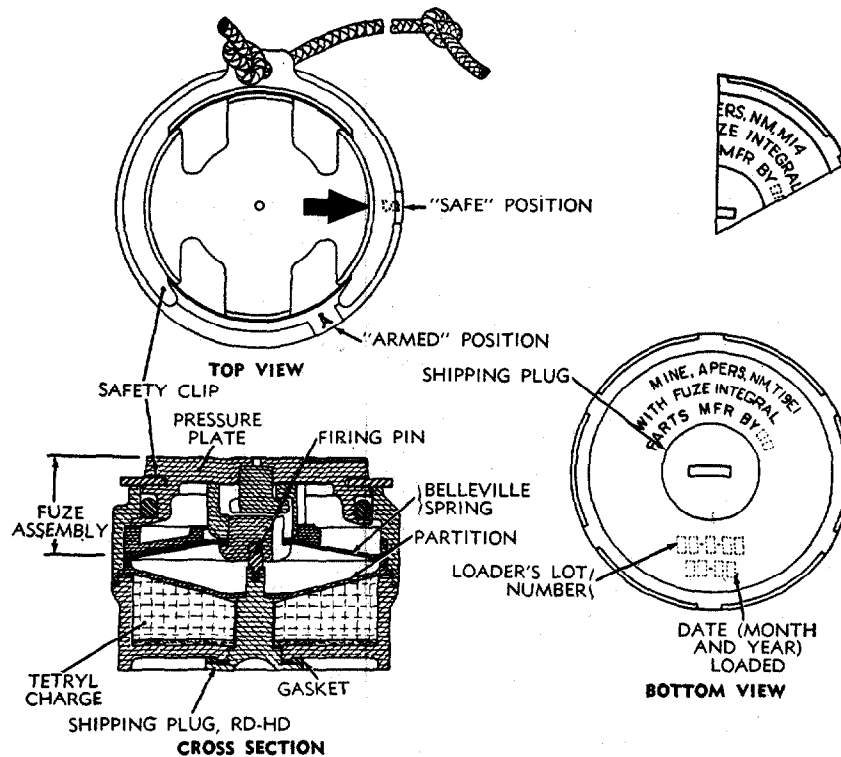

Fig 1-103 ANTIPERSONNEL MINE, NM, M14
W/INTEGRAL MINE FUZE

by means of a propellant charge of BkPdr, a shell filled with 0.34 pound of TNT to a height of 6 feet where it explodes. The mine is buried with fuze prongs near the surface but covered with earth

The Combination Fuze M605 for use in Bounding-fragmentation type mine M16 is described in Ref 32, pp 238-39 and shown in Fig 173 and in Ref 32b, pp 43-44 and shown in Fig 19. The mine M16 consists of a cylindrical cast-iron shell contg HE detonators, boosters, and bursting charge with axial fuze well (See Fig 1-105). When laid just below the surface of the ground, the mine is fitted with a combination (pressure and pull type) fuze M605. When initiated by pressure (8 to 20 lbs) on either of the three prongs of the fuze or by pull of 3 to 8 lbs on a trip wire attached to the release pin ring on the fuze, the expelling (pro-

PELLING) charge projects the cast-iron shell upwards to a height of 2 to 4 ft, igniting at the same time two delay elements of primer-detonators located inside bursting charges of the mine. The resulting explosion of the mine scatters the fragments inflicting casualties in a radius of 35 yards or more

There are many varieties of antitank mines and their body can be metallic or nonmetallic. The "service" mines can be subdivided into "heavy metallic" (20-30 lbs), "heavy-nonmetallic" (28 lbs) and "light A/T mines (5 lbs). Heavy A/T mines intended for use against heavy tanks, require a pressure of 300-500 lbs to initiate the fuze and are not dangerous to foot troops unless they attempt to run across them. Light mines require pressure of 140 to 240 lbs and are intended for use against light tanks or vehicles. A group of two or more light mines can be used against heavy tanks

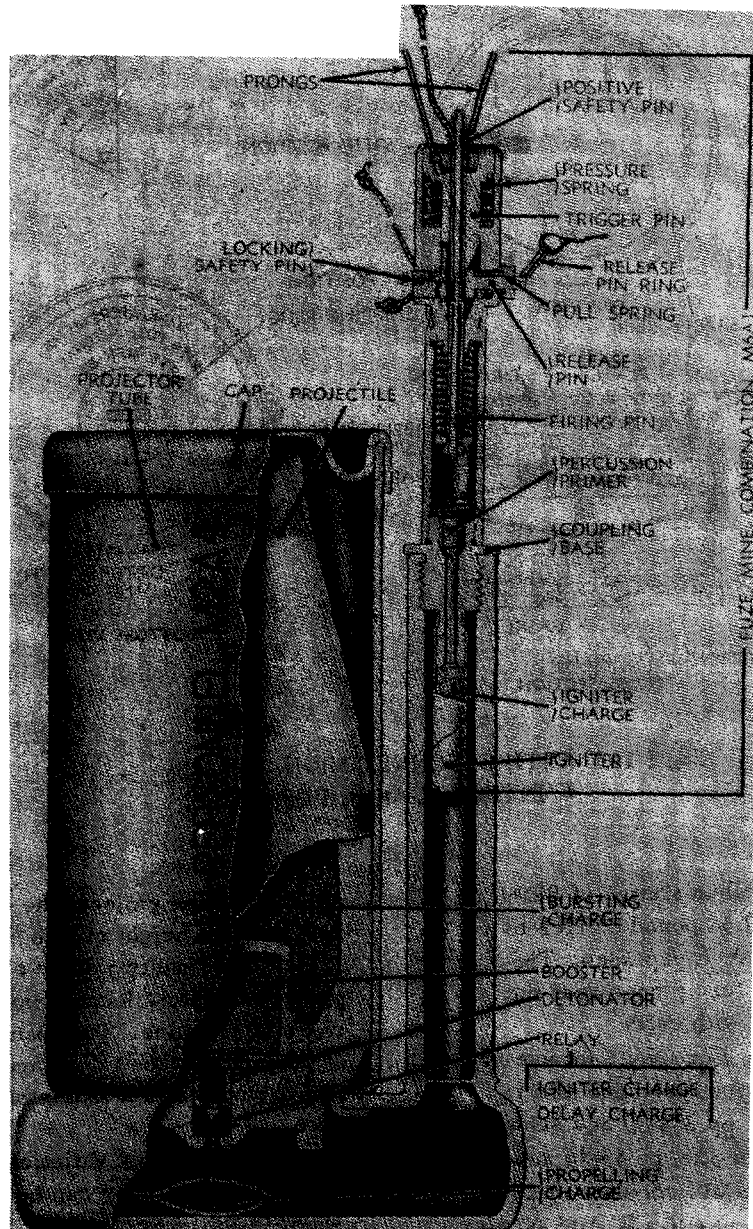

Fig 1-104 ANTIPERSONNEL MINE, M2A4
W/MINE FUZE, M6A1

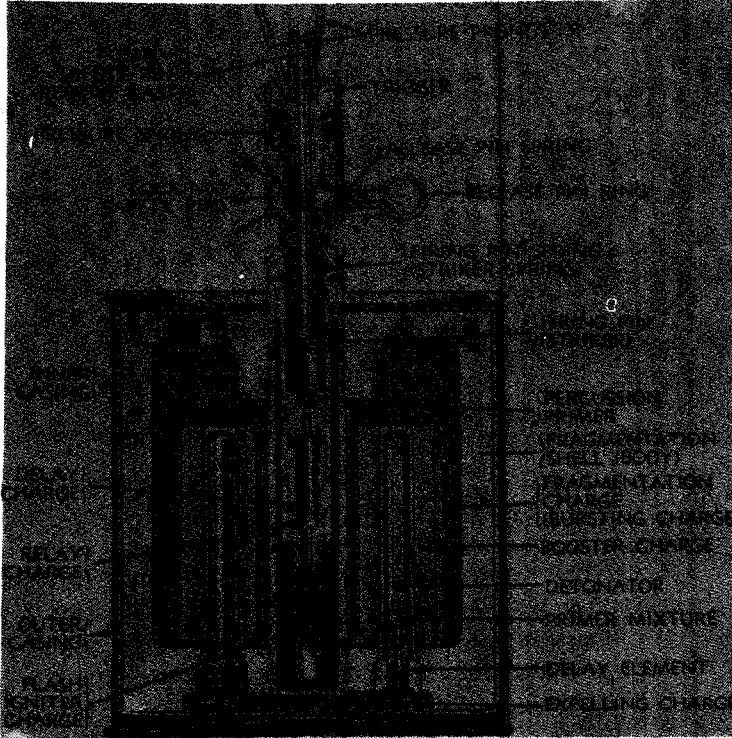

Fig 1-105 ANTIPERSONNEL MINE, M16
W/COMBINATION MINE FUZE, M605

Several types of A/T mines use Fuze M603 (T17E2) which is shown in Fig 1-106. The fuze is described in Ref 32, pp 252-53 and Ref 32b, pp 77-9. Its body is of aluminum, 1-1/8 inches in diameter & 1-3/16 inches high. It contains a firing pin assembly, a cover assembly, a safety fork (clip), and a detonator. The firing pin assembly consists of a firing pin and two nested steel Belleville springs held together by a retainer which is crimped to the firing pin. The cover assembly consists of a metal cover for the top of the fuze body and a pressure plate which is attached to the cover in such a manner that the safety fork may be inserted between the fuze body and the pressure plate. A detonator located in the detonator well is crimped to the body of the fuze. A projection at the bottom of the fuze body permits the detonator to come into close proximity to the booster charge when the fuze is inserted into the mine. All mines using fuze M603 are fitted with booster M120 in the bottom of the fuze well. The fuze functions when the Belleville springs (See in Fig 107, showing Heavy A/T Mine, M6A2) are depressed by appropriate pressure on the plate and snapped into reverse causing the firing pin to be driven into the detonator. When the fuze is used in heavy A/T mines (such as M6A2), a pressure of 300 to 400 lbs actuates the

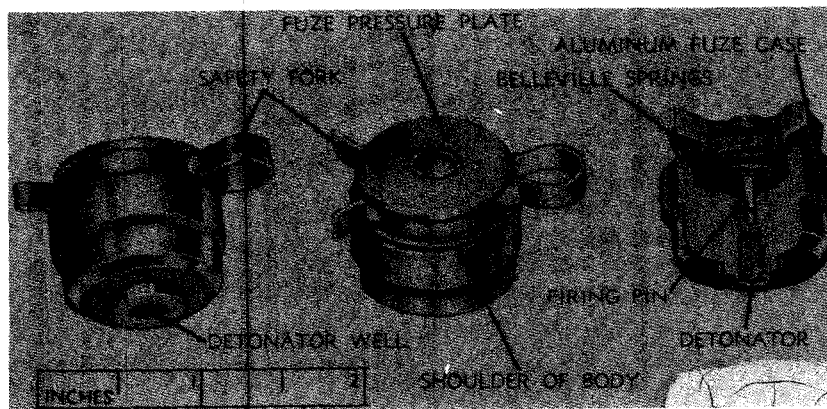

Fig 1-106 ANTITANK MINE FUZE, M603 (T17E2)

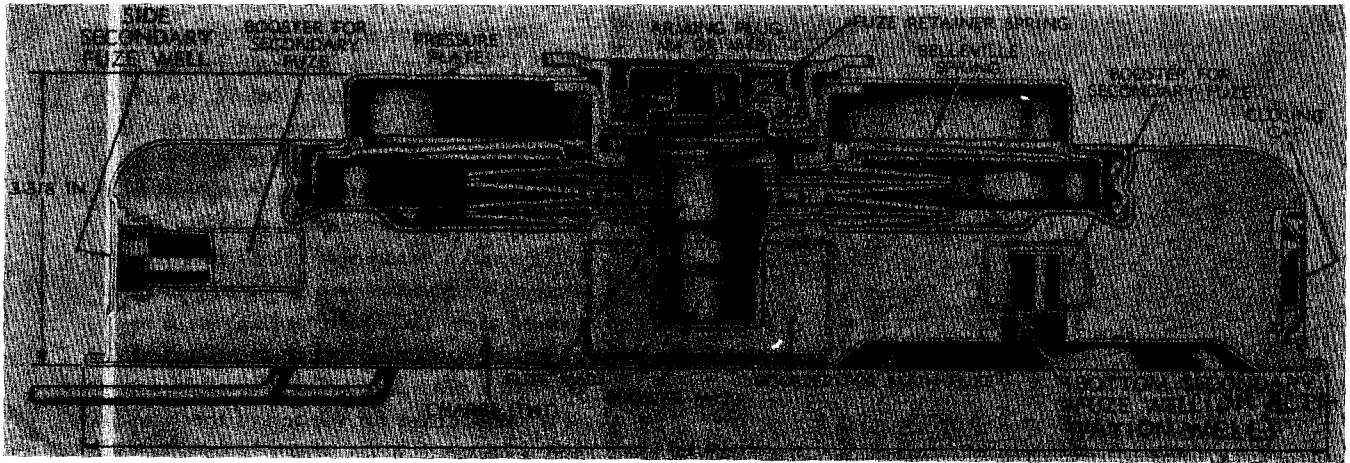

Fig 1-107 HEAVY ANTITANK MINE, M6A2
W/MINE FUZE, M603

fuze, while for light A/T mines (such as M7A2), a pressure of 140 to 240 lbs is required

The heavy mine M6A2 is described in Ref 32, pp 246-47 and shown in Fig 177. It is also described in Ref 32b, pp 69-71 and shown in Fig 31. The mine has steel body and is loaded with 12 lbs of TNT. Sometimes a special 8-lb block of TNT is added

The light mine M7A2 using fuze M603 is described in Ref 32, pp 246 & 248, Fig 178 and in Ref 32b, pp 79-80, Figs

38 & 39. The mine has metallic body and contains 3.6 lbs of Tetrytol. It is usually provided with a secondary fuze well, to adapt the mine to antipersonnel use

Mine Fuze M603 is also used in Mine A/T Heavy M15 (T27), which is described in Ref 32, pp 244-45, Fig 176 and Ref 32b, pp 85-91 and Figs 42 & 43. It is practically identical with M6A2 mine, except that its body is of thicker steel and contains 22 lbs of Comp B instead of 12 lbs TNT of M6A2

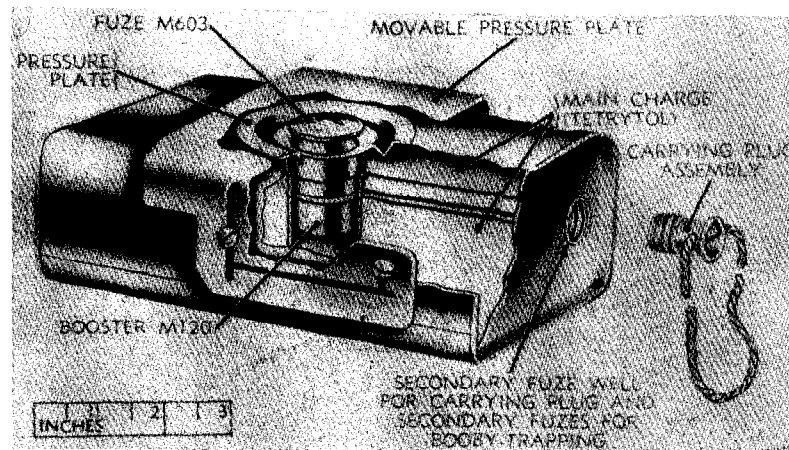

Fig 1-108 LIGHT, HE, A/T MINE M7A2
W/MINE FUZE, M603

Section 6
BOMBS AND BOMB COMPONENTS
Part A
Bombs

A brief description of US bombs is given in Vol 2 of Encycl (listed here as Ref 44), pp B225 to B241, but unfortunately some cutaway views of bombs given there are too small to understand the arrangements for installation of fuzes and other accessories. In order to understand more fully functioning of bombs we are including here larger cutaway views and more detailed description of current US bombs

According to the Technical Manual published in 1966 and listed here as Ref 51a, the new classification of US bombs is as follows: 1) Semi-Armor-Piercing (SAP) 2) Fragmentation (Frag) 3) General Purpose (GP) 4) Incendiary (Inc or I) 5) Fire 6) Smoke 7) Gas (G) and 8) Miscellaneous which include Aircraft Depth (AD), Leaflet, Photoflash and Practice bombs

Methods of stabilizing bomb flights are shown in Ref 44, Fig on p B227-L

Section 6, Part A

a) SAP (Semi-Armor-Piercing) Bombs

To the definition given in Ref 44, p B228-L may be added, SAP bombs have a heavy case and accommodations for both nose and tail fuzes. Since a nose fuze is seldom used, the nose seat is closed by an armor-piercing plug. The standard expl chge used in these bombs is Picratol (Amm picrate 52 & TNT 48%). This was mentioned in Ref 44. However, bombs contg TNT or Amatol may be encountered in earlier models, such as shown on p B228-R of Ref 44

The following SAP Bomb is described in Ref 51a, pp 2-1 to 2-2

1000-lb SAP Bomb AN-M59A, (Fig 2-1), has a thick steel body with outside diameter 15.09-in. The overall length of assembled bomb is 70.38 in and weight 1061 lbs when filled with 321 lbs of Picratol. It may use nose fuzes AN-M103A1, AN-M139A1, AN-M140A1, M163, M164, M165, M904E1 or M904E2 and tail fuzes AN-M102A2, AN-M117, AN-M125A1, AN-M134, M161 (Modification)

or M162

Note: No Armor-Piercing (AP) bombs are described in Ref 51a, although they were described in earlier Technical Manuals (such as in Ref 19b). They are also briefly described in Ref 44, p B222-L, where cutaway views of two types of AP bombs are given

Section 6, Part A

b) Frag (Fragmentation) Bombs

A brief description is given in Ref 44, p B228-R, where also are given Figs of fin-type and parachute-type bombs. A 4-lb Butterfly bomb and its photographic view is found on p B239-L of Ref 44

The following Frag bombs are described in Ref 51a, pp 2-6 to 2-17

4-lb Frag Bomb M83, has cylindrical body diam 3.12-in and overall length 11.13-in. Its wt is 3.8-lb, which includes 0.5-lb of filler, which can be Comp B, Ednatol or TNT. It is assembled at the factory manufg the bomb with a fuze, which is mounted midway betw the cylinder ends. One of the following fuzes has been used: M129, M129A1, M130, M130A1, M131 or M131A1. Its outside appearance is the same as given in Fig, p B239-L of Ref 44. It is used in cluster M28A2 (Ref 51a, pp 2-6 to 2-8)

20-lb Frag Bomb AN-M41A1, is of a shape similar to that shown for fin-type Frag bomb in Fig, p B228-R of Ref 44. Its body, constructed in the same manner as described below for 90-lb Frag bomb, has diam 3.64-in. Its overall length is 22.4-in, and total wt ca 19.75-lb which includes either TNT (ca 2.7-lb) or Amatol (ca 2.6-lb). It uses nose fuzes AN-M110A1, AN-M158, or AN-M120A1 and is assembled in clusters such as AN-M1A2 (Ref 51a, pp 2-9 & 2-10)

23-lb Frag Bomb M40A1, is a parachute-type designed for assembly in clusters (such as M4A2), but also authorized for single suspension use. It is similar in appearance to Fig given in Ref 44, p B228-R and has body diam 4.37-in, overall length 30.15-in and weighs 24.8-lb when loaded with 2.7-lb of 75/25-Cyclotol or Grade 1 TNT. It uses nose fuzes M170 (with detonator M18A2), AN-M120A1 or AN-M120 (Ref 51a, p 2-11)

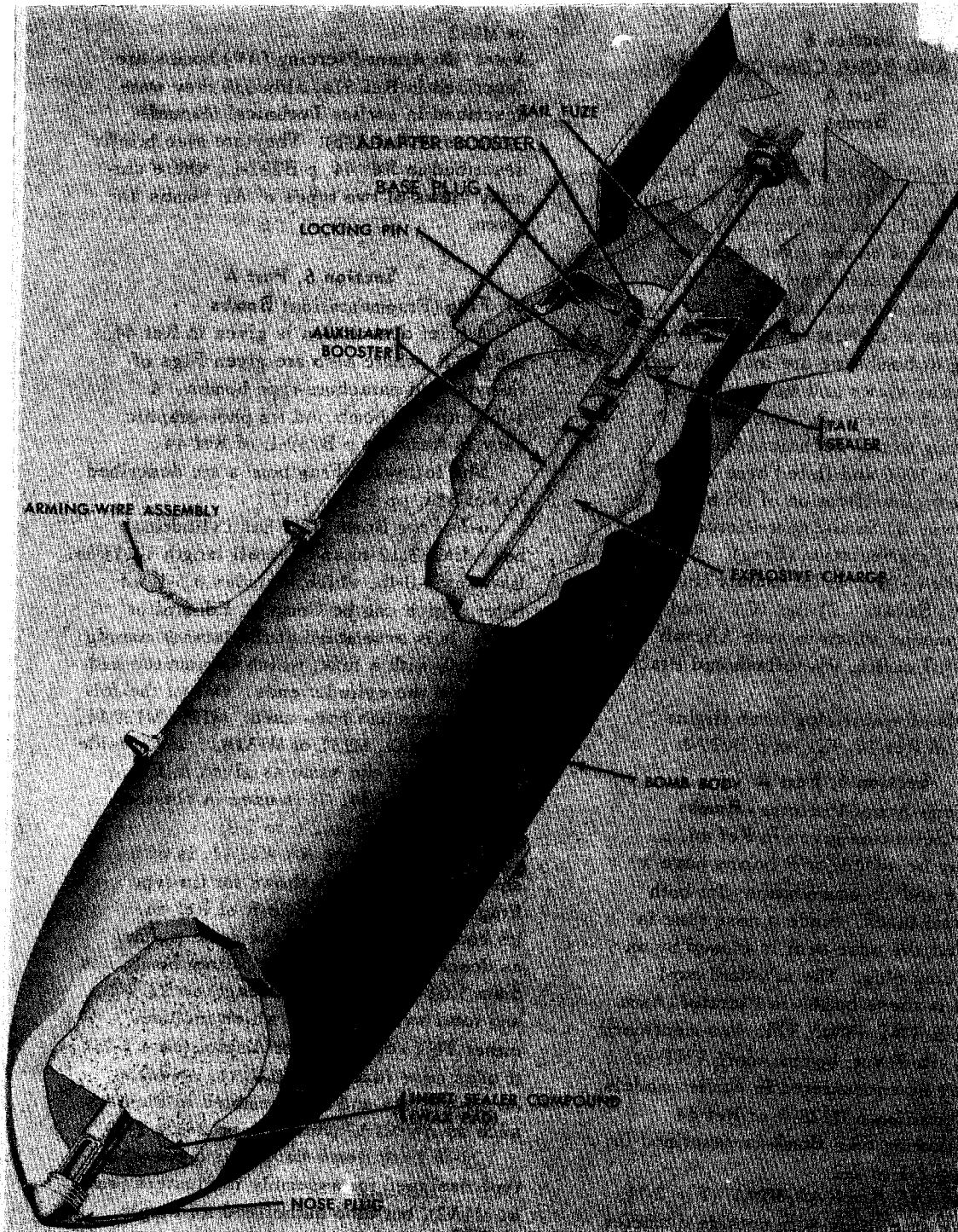

Fig 2-1 1000-lb SAP BOMB, AN-M59A1

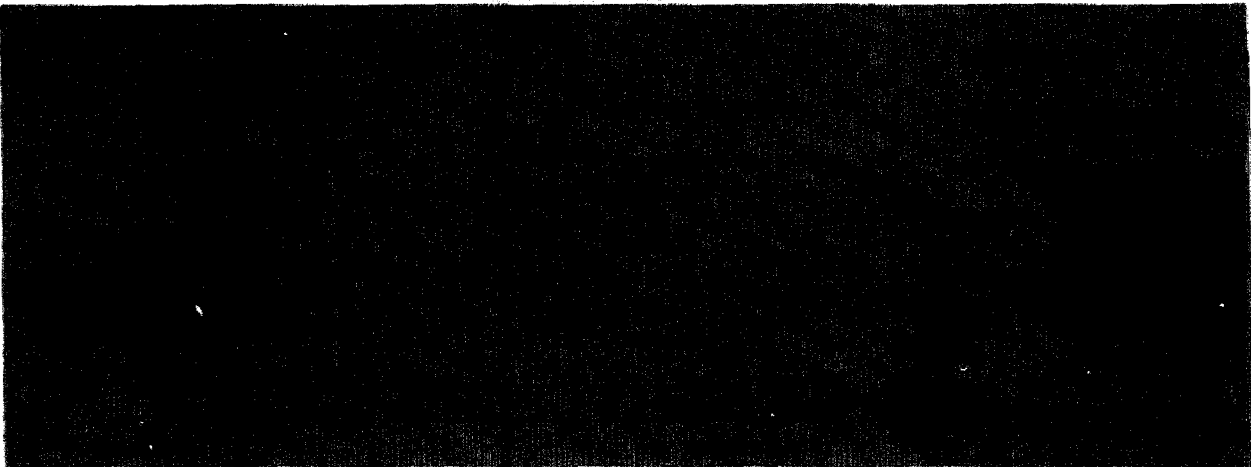

Fig 2-2 90-lb FRAG BOMB, M82

90-lb Frag Bomb M82, is constructed of square, steel wire, spirally wound on a seamless steel inner tube, as shown in Fig 2-2. A rounded nose piece houses the nose fuze, and a box-type fin assembly is attached to the tapered aft end of steel tube by a fin lock nut. The steel wire is forged at the nose and at the tail to form a solid body. The bomb can be used either in single suspension or in clusters (such as M27A1)

When adopted for single suspension (by suspension lug welded to the body), only instantaneous or VT fuzes are used, but fitting of a mechanical time fuze is permitted with the addition of an adapter-booster. Its body diam is 6.06-in, length (with fin assembly M101) 28.0-in, total weight 86.6-lb (when loaded with 11.4-lb of Comp B), or 87.4-lb (when loaded with 12.3-lb of TNT)

Following nose fuzes have been used (for nondelay action only) with M82 bombs: AN-M103A1 (shown here in Fig 4-1), M904E1, M904E2, AN-M139A1, AN-M140A1, AN-M166 (VT), AN-M166E1 (VT), AN-M168 (VT), M163, M164, M165 or M188 (VT) (Ref 51a, pp 2-12 & 2-13)

260-lb Frag Bombs AN-M81 and AN-M88, (shown here in Fig 2-3), are similar. They are constructed in the manner described for the 90-lb Frag Bomb, except that they use

heavier materials. Their diam is ca 8.12-in and overall length is 43.7-in (when using fin-assembly AN-M103A1) or 58.0 (when using fin assembly M135). Their filler is either Comp B (41.1-lb for AN-M88 and 36.0 for AN-M81) or TNT (41.2 for AN-M88 and 34.5 for AN-M81). Total wt of bombs depends on type of fin assembly and kind of filler and varies from 216.2-lb to 231.1-lb for AN-M88 and from 261.5-lb to 276.5-lb for AN-M81 bomb. Their nose fuzes include: AN-M103A1, M904E1, M904E2, AN-M139A1, AN-M140A1, M166 (VT), AN-M168 (VT), M188 (VT), M163, M164 or M165. They also have used tail fuzes: AN-M100A2, AN-M175 & M172 (Ref 51a, pp 2-14 to 2-18)

Section 6, Part A

c) GP (General Purpose) Bombs

A brief definition of general purpose bombs, when they were considered as one of the types of "demolition bombs", was given in Ref 44, p B228-L. Another type of "demolition bomb" was LC (light case), of which the heavy (4000-lb) bomb was called "blockbuster"

GP Bombs are subdivided in Ref 51a, into: a) Old Series; b) New Series; c) Low-Drag; and d) Low-Drag Snakeye I

Old Series GP Bombs, to which belong 100-lb AN-M30A1, 250-lb AN-M57A1, 500-lb

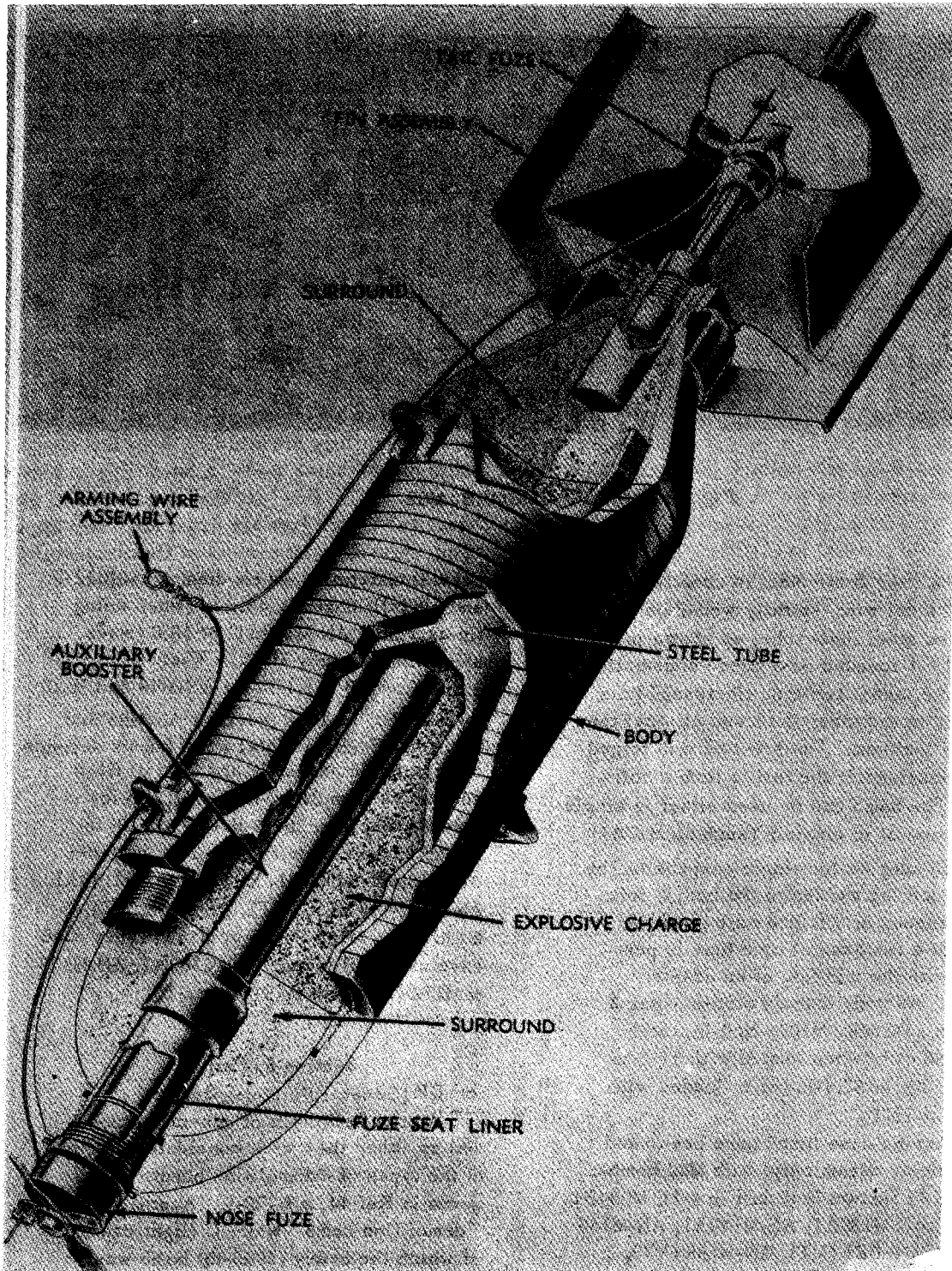

Fig 2-3 260-lb FRAG BOMB, AN-M88

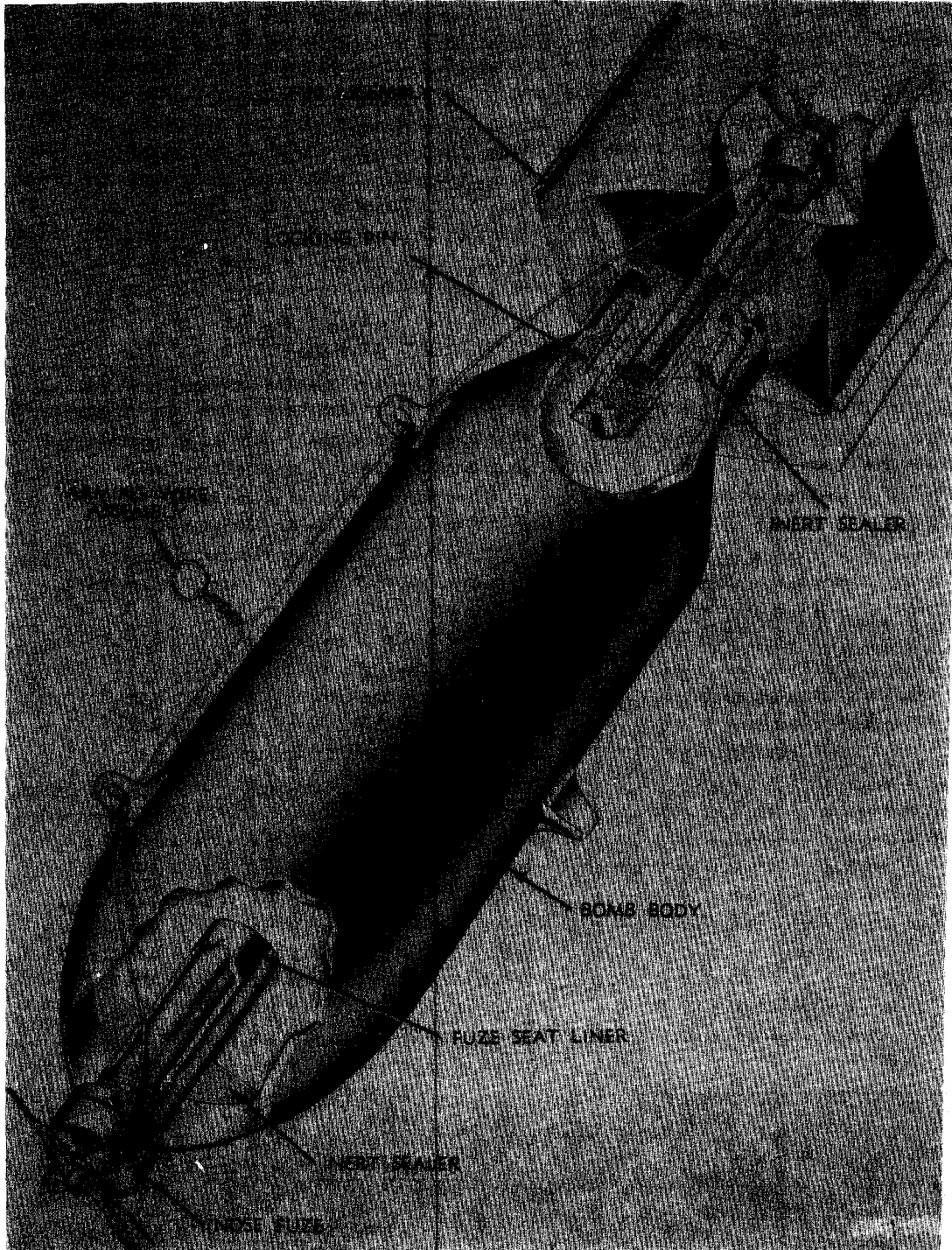

Fig 2-4 GP BOMB (Old Series)

AN-M61A1, 500-lb AN-M64A1, 1000-lb AN-M65A1 and 2000-lb AN-M66A2, can be represented by Fig 2-4 although their dimensions vary with the wt of filler, as can be seen from tables given on pp 2-19 to 2-26 of Ref 51a. These bombs are relatively thin-cased, with an ogival nose, parallel side walls, and tapered aft section. They are similar to "light case" bombs listed in Ref 44, p B228-L. Their filler, which can be TNT, 50/50-Amatol or Tritonal in 100 & 250-lb bombs and TNT, 50/50-Amatol, Comp B or Tritonal in 500, 1000 & 2000-lb bombs, comprises ca 50% of total wt of the bomb. More complete description of GP, Old Series bombs is given in Ref 51a, pp 2-18 to 2-26)

About 14 types of nose fuzes (of which 4 types are VT fuze) are used in GP bombs, old series, in addn to 8 types in tail fuzes

New Series GP Bombs are not listed in Ref 44, but two of such bombs: 750-lb M117 and 3000-lb M118 are described in Ref 51a, pp 2-26 & 2-27. They are designed for high blast effects and for improved aerodynamic performance & accuracy in flight when released from most altitudes and airspeeds. Their bodies are cigar-shaped with a conical fin-assembly bolted to the rear. This can be seen from Fig 2-5. The Fig 2-20 of Ref 51a showing their cutaway view is not reproduced here because its lines are too faint to understand the inside construction

Dimensions of 750-lb, M117 bomb are: diameter 16.1 inches, overall length 89.4, and total wt 823.0-lb when loaded with 386.0-lb of Tritonal

Dimensions of 3000-lb, M118 bomb are: diam 24.13-in, overall length 185.0 and wt 3049-lb when loaded with 1975-lb of Tritonal

These bombs can use twelve types of nose fuzes (of which several are VT and some are electrical) and four types of tail fuzes. For electric fuzing they are equipped with two conduits connecting the nose & tail fuze cavities with a charging receptacle located between two suspension lugs

Section 6, Part A

d) Low-Drag GP Bombs

These bombs were not described in Vol 2 of Encycl. They are long and more slender than earlier types of GP bombs, and have a long pointed nose. A streamlined fin is attached to the tail end of the bomb body by 6 or 8 setscrews. These bombs use mechanical, proximity (VT), or electrical fuzes. The cutaway view of these bombs is given in Fig 2-6.

Four sizes of low-drag bombs are described in Ref 51a, pp 2-27 to 2-30:
Mk81Mod1. Diameter 9.0 inches, length 74.1, total wt 260.0-lb and wt of filler (Tritonal or H6) 100.0-lb; can use 14 types of nose fuzes, three types of tail fuzes and one type of nose-tail fuze - M913 (VT)
Mk82Mod1. Diameter 10.75-in, length 86.90, total wt 531.0-lb and wt of filler (Tritonal or H6) 192.0-lb, can use 13 types of nose fuzes, three types of tail fuzes and the same type of VT nose-tail fuze as above
Mk83Mod3. Diameter 14.0-in, length 118.42, total wt 985.0-lb and wt of filler (Tritonal or H6) 445.0-lb; can use 14 types of nose fuzes, 6 types of tail fuzes and the same

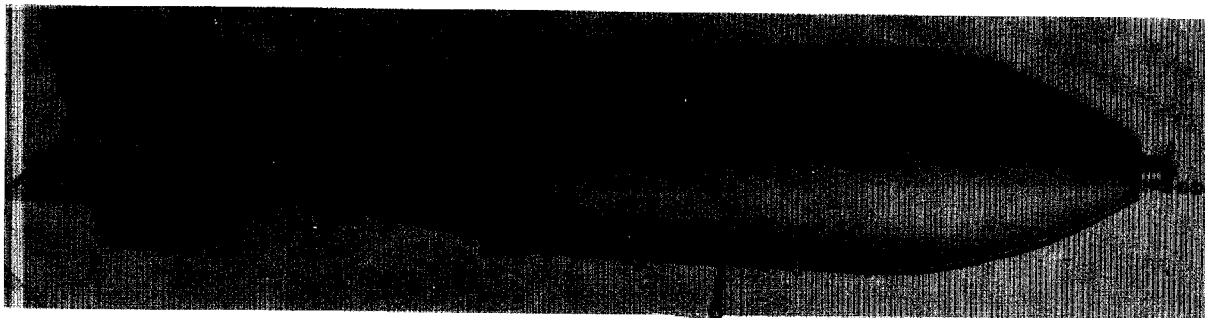

Fig 2-5 GP BOMB (New Series)

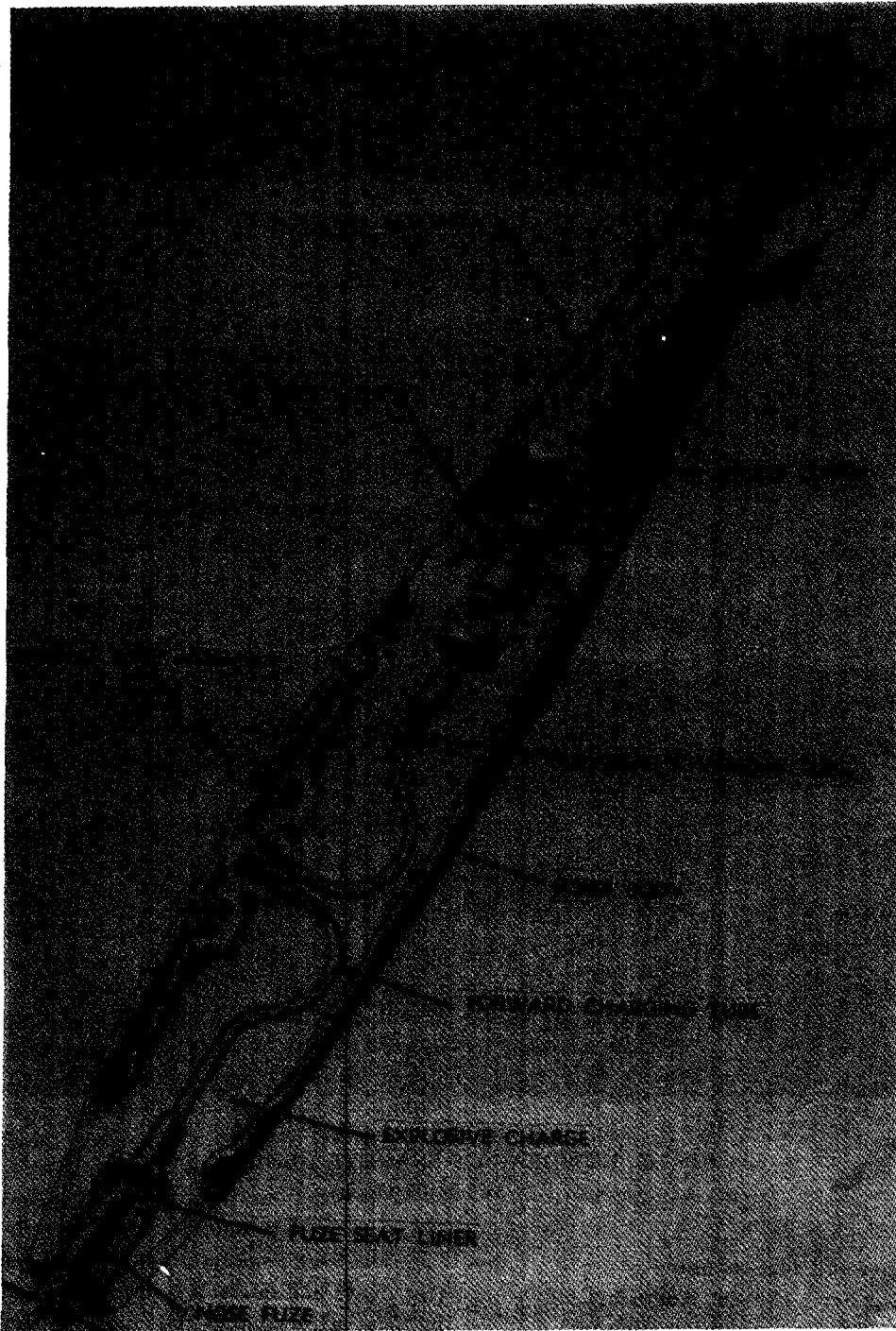

Fig 2-6 LOW-DRAG GP BOMB

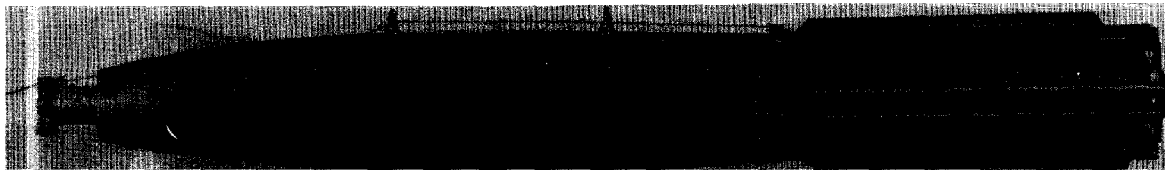

Fig 2-7 LOW-DRAG GP SNAKEYE I BOMB
(With Fin-Assembly Closed)

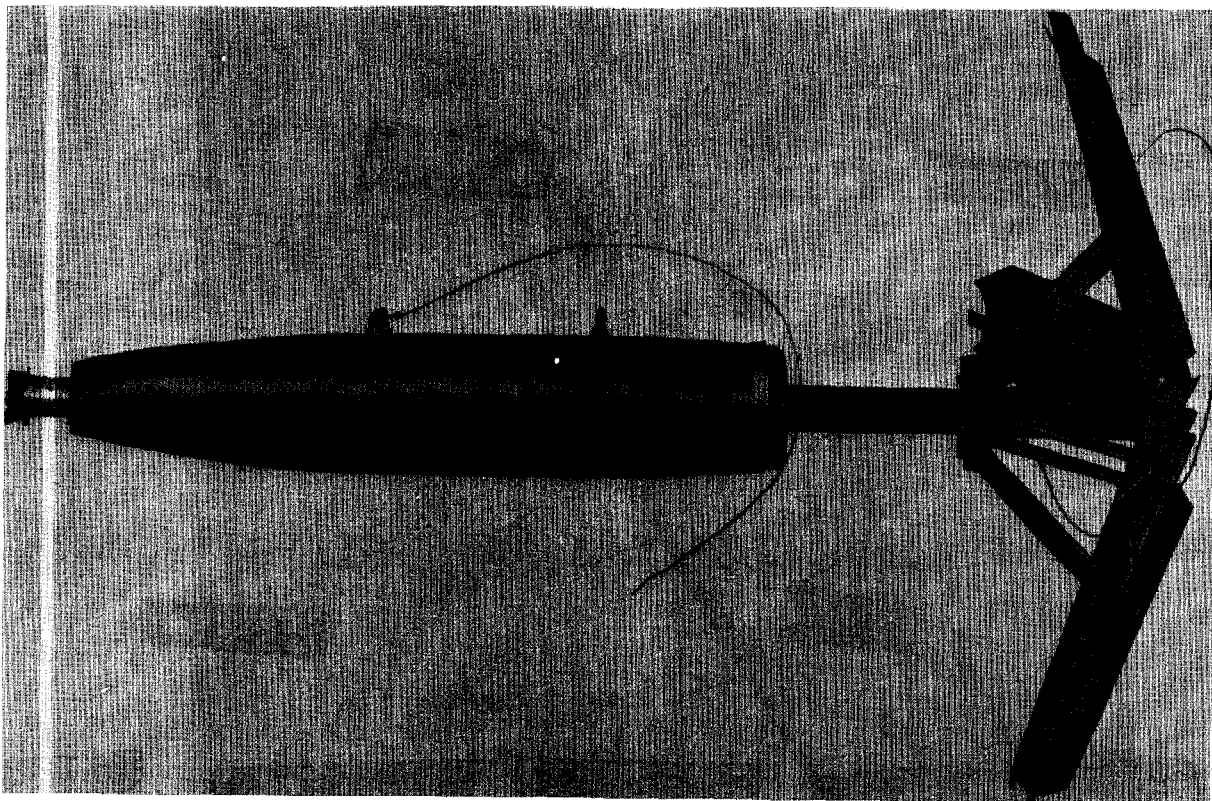

Fig 2-8 LOW-DRAG GP SNAKEYE I BOMB
(With Fin-Assembly Open)

type of VT nose-tail fuze as above
Mk84Mod1. Diameter 18.0-in, length 151.50,
total wt 1970.0-lb and wt of filler (Tritonal
or H6) 945.0-lb; can use 12 types of nose
fuzes, 4 types of tail fuzes and the same
type of VT nose-tail fuze as above

There are also *Mk81Mod0*, *Mk82Mod0*,
Mk83Mod2 and *Mk84Mod0* which are original
models of the above and very similar to
them (Ref 51a, pp 2-27 to 2-30)

Low-Drag Snakeeye I Series GP Bombs
(not described in Ref 44), are characterized
by their tail assembly, consisting of four
blades which can be quickly unfolded (like
an umbrella) (Fig 2-8), by a special mecha-
nism in cases when high-speed, low-altitude
bombing is required. The resulting "high-
drag" decelerates the flight of the bomb
so that it can impact at larger angles with
respect to the ground. If the tail assembly
remains folded, the bomb becomes low-drag
(Fig 2-7)

The following GP Low-Drag Snakeye I bombs are described in Ref 51a, pp 2-31 & 2-32:

- 1) 250-lb Mk81Mod1, Snakeye I. Diameter 9.0-inches, length 75.0, total wt 300.0-lb, and wt of filler (compn not given) 100.0-lb; can use 8 types of nose fuzes, 6 types of tail fuzes and nose-tail system M913(VT)
- 2) 500-lb Mk82Mod1, Snakeye I. Diameter 10.8-in, length 89.5, total wt 560-lb and wt of filler (compn not given) 192.0-lb; can use 8 types of nose fuzes, 6 types of tail fuzes and the same nose-tail assembly as above

Section 6, Part A

e) Inc (Incendiary) Bombs

Their brief description is given in Vol 2 (Ref 44), p B229, where small cutaway views of 2-lb and 4-lb bombs (with bodies made of Mg) are included. A more complete description, especially of the German "Elektron Bombe" (with body made of Mg alloy) is given in Ref 44, pp B234 to B237

To the list of incendiary fillings given on p B229 of Ref 44, may be added the following mixtures: **IM** (gasoline thickened with isobutylmethacrylate); **PT1** (mixt of Mg powder with gasoline & other petroleum products thickened with isobutylmethacrylate); **TH1** (Thermite); and **TH3** (mixt of TH1 with Ba nitrate & sulfur in an oil binder). Abbr **NP** stands for Napalm, which

is gasoline and some other petroleum products thickened with Al soap or other thickeners, some of them are classified

Two 4-lb TH3 Inc Bombs, AN-M50A3 and M126, described in Ref 51a, pp 2-33 to 2-38, are made of Al alloy. AN-M50A3 bomb resembles in appearance the fig given in Ref 44, p B229-L, whereas M126 bomb is shown here on Fig 2-9. Both bombs are of similar construction except that the M126 has the fin assembly M15 in place of a hollow sheet-steel section of AN-M50A3 bomb

The M15 fin assembly consists of retractable fins (6 of Fig 2-9) in a hollow sheet steel body (4) with the fins extending thru longitudinal slots in the fin body by depression of a spring-loaded tail plunger (5) at the rear of the bomb. The fins are secured to the bomb body (2) by the holder and firing assembly (7). The front end of the bomb is closed with a solid iron nose (8) which weights the bomb so that it falls nose downward and penetrates target without crumbling on impact

While the bomb is in cluster M36, the spring-loaded safety plunger (3) (called also arming plunger), is depressed by contact with another bomb in the cluster, thus keeping the firing assembly unarmed. Depression of the spring-loaded tail plunger (5) retracts the fins (6) into the fin body

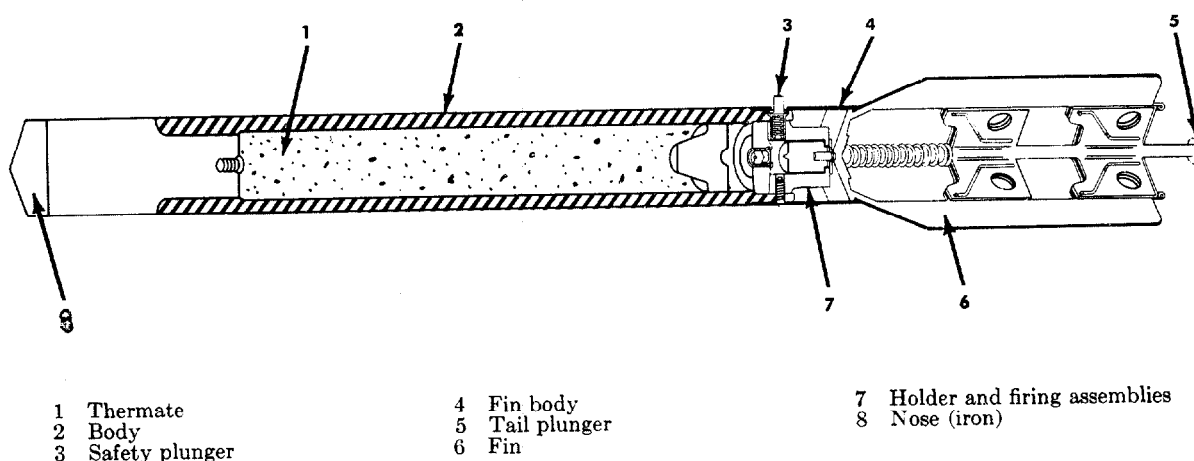

Fig 2-9 4-lb TH3 INC BOMB, M126

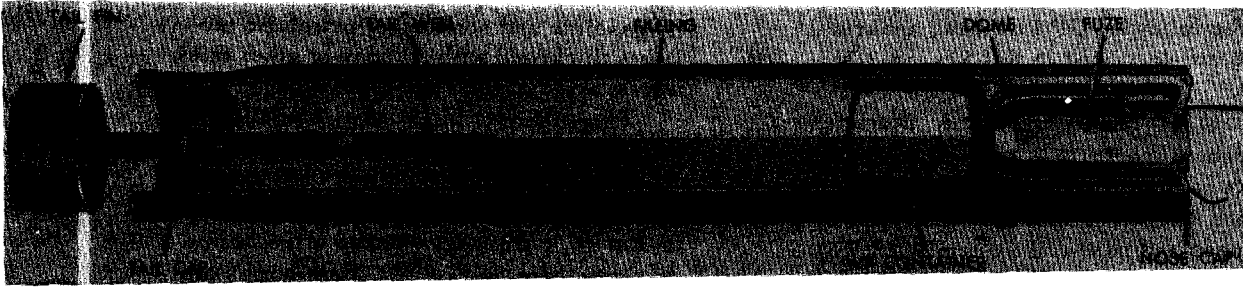

Fig 2-10 10-lb PT1 INC BOMB, M74A1

(4) and holds them retracted as long as (5) is held in a depressed position

When the bomb is released from the cluster for flight, the tail fins are extended by the force of the tail plunger's spring and the arming plunger (3) is forced outward by its spring, thus arming the bomb's firing assembly (7)

When the bomb strikes the target, inertia causes the firing pin to move forward striking the primer. The primer ignites the "first fire mixture" which ignites the filler (1) (0.63-lb of Thermate, TH3) and the Mg alloy body (2)

A larger incendiary bomb is the *10-lb PT1, M74A1 Bomb*. It uses *Nose Fuze M197* (shown on Fig 4-5) or *M142A*. The steel body of bomb (See Fig 2-10), is hexagonal in shape, except for the tail end which is round (See Fig 2-10). Length of assembled bomb is 19.5-inches, width of hexagonal part 2.8-in, wt of PT1 filler 2.75-lb (Mg powder mixed with gasoline & other petroleum products thickened with isobutyl-methacrylate) and total wt of bomb 8.5-lb. The nose end of the bomb is closed by a sheet-steel nose cup which provides a seat for the fuze. The tail end of the bomb is closed by a sheet-steel cup with a well in its center to provide a mounting for the fin assembly. Behind the nose cup is located the dome. It separates the fuze from the filling of PT1 and forms a container for two small bags of Mg/BkPdr mixture. About 6 oz of WP (white phosphorus) enclosed in a plastic bag is placed behind the dome and ahead of PT1. When the bomb strikes a target, the fuze functions and sets off

Mg/BkPdr mixt in the dome. Gases released on burning blow the dome toward the tail end of the bomb. This action rejects PT1, WP, the tail cup and the tail assembly from the bomb. The WP ignites upon exposure to the air and sets fire to PT1. The scattered jelly burns 5 to 10 mins (Ref 51a, pp 2-39 & 2-40)

The largest of the incendiary bombs described in Ref 51a is the *100-lb AN-M47A4 Inc Domb* (See Fig 2-11). Its preferred fuze is the *Nose Fuze AN-M159* (See Fig 4-6), while *AN-M126A1* (described in Ref 51a, pp 4-7 to 4-9) is its authorized alternate. The fuzes are shipped separately from the bomb and are installed during assembly of the bomb

The bomb *M47A4* is designed for use against combustible land targets where large and numerous fires will cause serious damage and for use in igniting oil slicks on water. The types of land targets against which the incendiary bomb is effective include warehouses, factories, docks, storage dumps, barracks, and residential and industrial structures. When ships in a harbor or oil storage tanks near a harbor are damaged, oil slicks are formed which are frequently of sufficient thickness to be ignited by incendiary bombs and to burn intensely. It is ca 52 inches long and weighs ca 68 lb. It is ca 8.1 inches in diameter and has a rounded nose, a truncated conical tail section, and a fixed tail fin. The complete round consists of a bomb body, incendiary filling, a burster, a fuze, and an arming wire

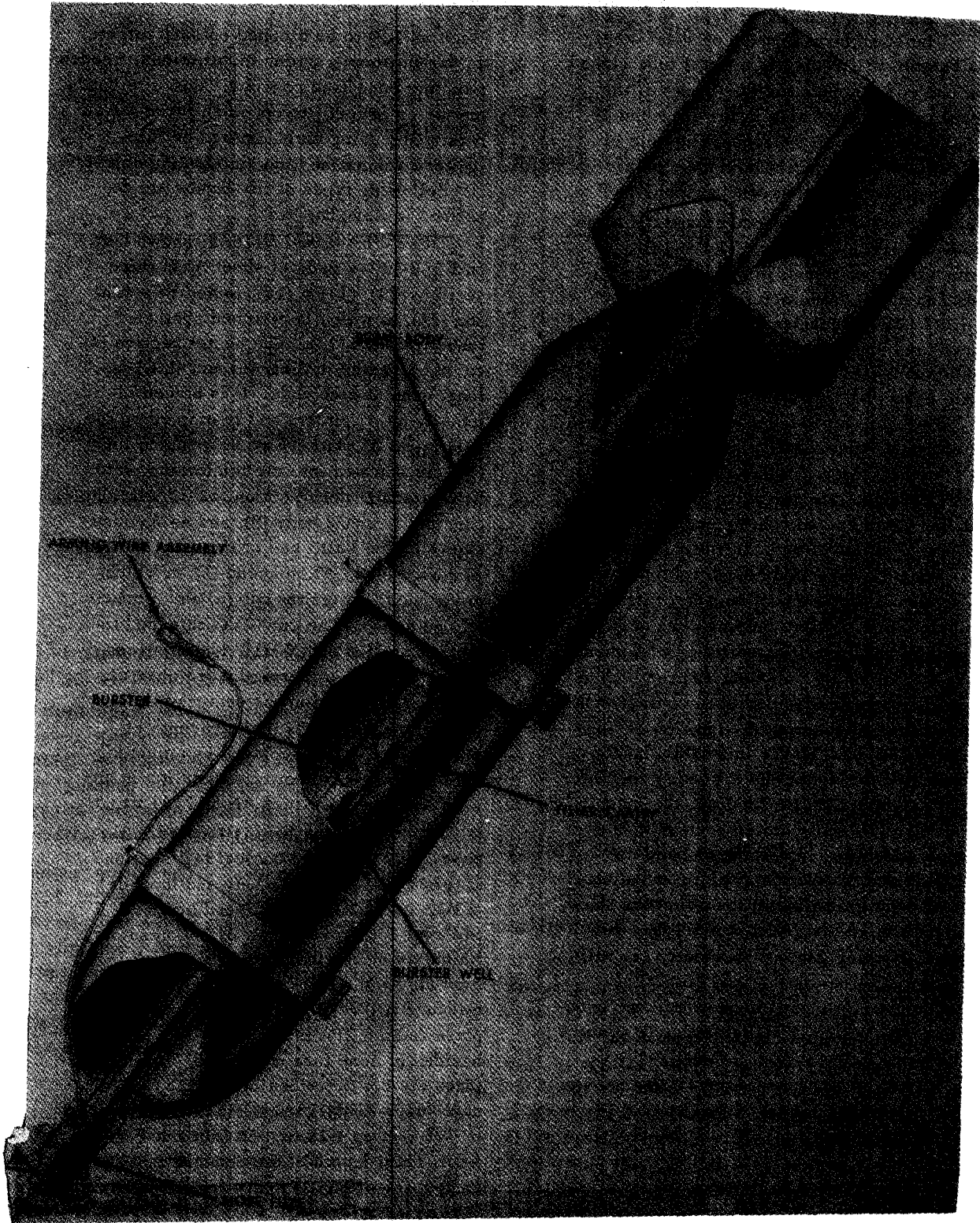

Fig 2-11 100-lb INC BOMB, AN-M47A4

The bomb body is made of sheet steel. A burster well, which is a metal tube closed at one end, extends the full length of the bomb. A threaded hole in the nose end of the bomb receives the fuze. The hole is closed during shipment by a nose plug. Two suspension bands with suspension lugs at the top are clamped around the bomb body by machine screws. The tail fin, which has four vanes, is welded to the tail section during manufacture

Its filling consists of ca 42-lb PT1, IM or NP and bursters AN-M12 or AN-M13, all shipped separately from the bomb. Arming wire used with this bomb

When this incendiary bomb equipped with a white phosphorus (WP) igniter impacts on a structural target, it bursts and scatters gobs of incendiary gel which stick to surfaces contacted and continue to burn. The effective radius of burst is 10 to 15 yards

When the incendiary bomb equipped with a sodium igniter impacts on water targets, it bursts and scatters burning gobs of incendiary gel containing particles of sodium. These gobs of gel will float and the sodium will ignite spontaneously upon contact with water, thereby insuring the ignition of flammable oil slicks. If the incendiary bomb penetrates the surface of a wooden dock or pier and bursts below the dock, the incendiary gel will still burn on contact with water. However, if a white phosphorus-filled igniter is used in place of a sodium igniter, the scattering of the gel takes place, but ignition of the gel on water is not assured. Burning gobs of incendiary gel will produce a temperature of 500° to 675°C at a height of 3 inches above the flame over a maximum period of approximately 8 minutes

The AN-M47A4 bomb is identical to the AN-M47A3 except that the A4 has heavier gage suspension lugs than the A3 (Ref 51a, pp 2-33 to 2-35)

Section 6, Part A

f) Fire Bombs

These bombs (not described in Ref 44) consist of thin-walled containers filled with thickened petroleum products fuels

(such as NP) to be dropped on such targets as dug-in troops, supply installations, wooden structures and land convoys. Most fire bombs rupture on impact (except when fuzed for air burst), spreading fuels, ignited by fuze-igniter combinations, on surrounding objects

Following types of fire bombs are described in Ref 51a:

750-lb Fire Bomb, M116A2, shown here on Fig 2-12, is made of sheet Al in three sections, (8), (11) & (14), joined by a seal ring (23), to which is attached synthetic rubber gaskets (22). The center section is ca 18.63 inches in diameter and 48.63-in long, open at both ends. It is braced internally by Al girders and reinforced on the side by an Al plate. Two suspension lugs (13) are screwed into the reinforcing plate. The parabolic nose section, ca 32.5-in long, consists of an Al body (8), and an Al nose cap (1). The small end of the nose section is closed by an Al bulkhead (3) on which are mounted an igniter cup (2) and a nose-cap guide (4). The cup (2) is threaded to receive an M23 or AN-M23A1 igniter (not shown on Fig). A spring-loaded nose-cap plunger (5) is held in the center of the nose-cap guide (4) by a short length of steel wire which is replaced by an arming wire (12) when the bomb is installed in an aircraft. The nose fuze AN-M173A1 or M173 (not shown on Fig) is located in the nose. The truncated conical tail section (14) is ca 39.25 inches long and is made of Al. Its small end is closed by an Al tail cone (30) covering an Al bulkhead on which are mounted an igniter cup with igniter (17) and a tail-cone guide (16). A tail fuze AN-M173A1 or M173 (located in place marked 21), is used with this bomb besides of nose fuze mentioned. Its tail fuzes are not described in Ref 51a, while nose fuzes AN-M173A1 & M173 are described in Ref 51a, pp 4-28 to 4-30 (See our Fig 4-9). Total length of the bomb is ca 137 inches, its wt 685-lb and wt of NP filler 615-lb (100 gallons)

Upon release of the bomb from the aircraft, the arming wires are simultaneously withdrawn from the nose-cap plunger (5)

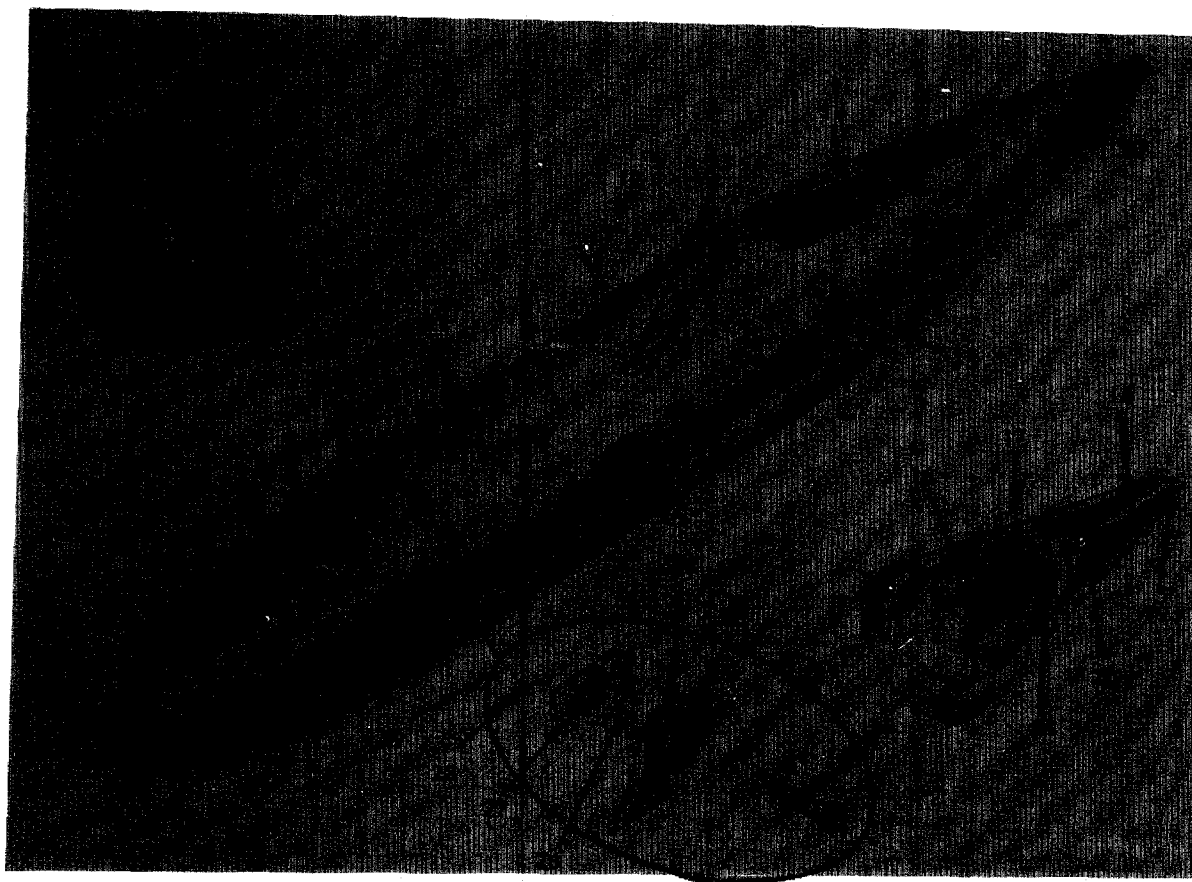

- | | | |
|----------------------|----------------------|----------------------------------|
| 1 Nose cap | 11 Center section | 21 Fuze |
| 2 Igniter cup | 12 Arming wire | 22 Gasket |
| 3 Bulkhead | 13 Suspension lug | 23 Seal ring |
| 4 Nose-cap guide | 14 Tail section | 24 Sealing washer |
| 5 Nose-cap plunger | 15 Locking screw | 25 Locking bolt |
| 6 Assembly mark | 16 Tail-cone guide | 26 Spring |
| 7 Filling hole | 17 Igniter | 27 Clamp |
| 8 Nose section | 18 Tail-cone plunger | 28 Cotter pin |
| 9 Filler cap | 19 Nut | 29 Clamp assembly, exploded view |
| 10 Arming-wire guide | 20 Spring | |

Fig 2-12 750-lb FIRE BOMB, M116A2

and nose & tail fuzes. The nose cap (1) and tail cone (30) are ejected by their respective springs. This exposes nose and tail fuzes. The nose-cap guide (4) is forced by its spring to lie flat against the bulkhead (3). The arming vanes in the fuzes become free to rotate in the airstream when the arming wires are withdrawn and the nose cap and tail cone are out of the way. Approximately 15 revolutions of the arming vanes are required to arm the fuzes. Both fuzes function on impact. They burst the

igniters, causing the WP to scatter and to ignite on coming in contact with the air. The force of the impact bursts the bomb, scatters the NP filler (already ignited by WP), splattering it over the target area (Ref 51a, pp 2-40 to 2-43)

750-lb Fire Bomb, Mk77Mod0 is similar in appearance and construction to M116A2 bomb, except that it contains 666-lb of gelled gasoline. It uses fuzes M157, M173 and AN-M173A1 (Ref 51a, pp 2-44 & 2-45)

Fire Bomb 500-lb, Mk77Mod1 is similar

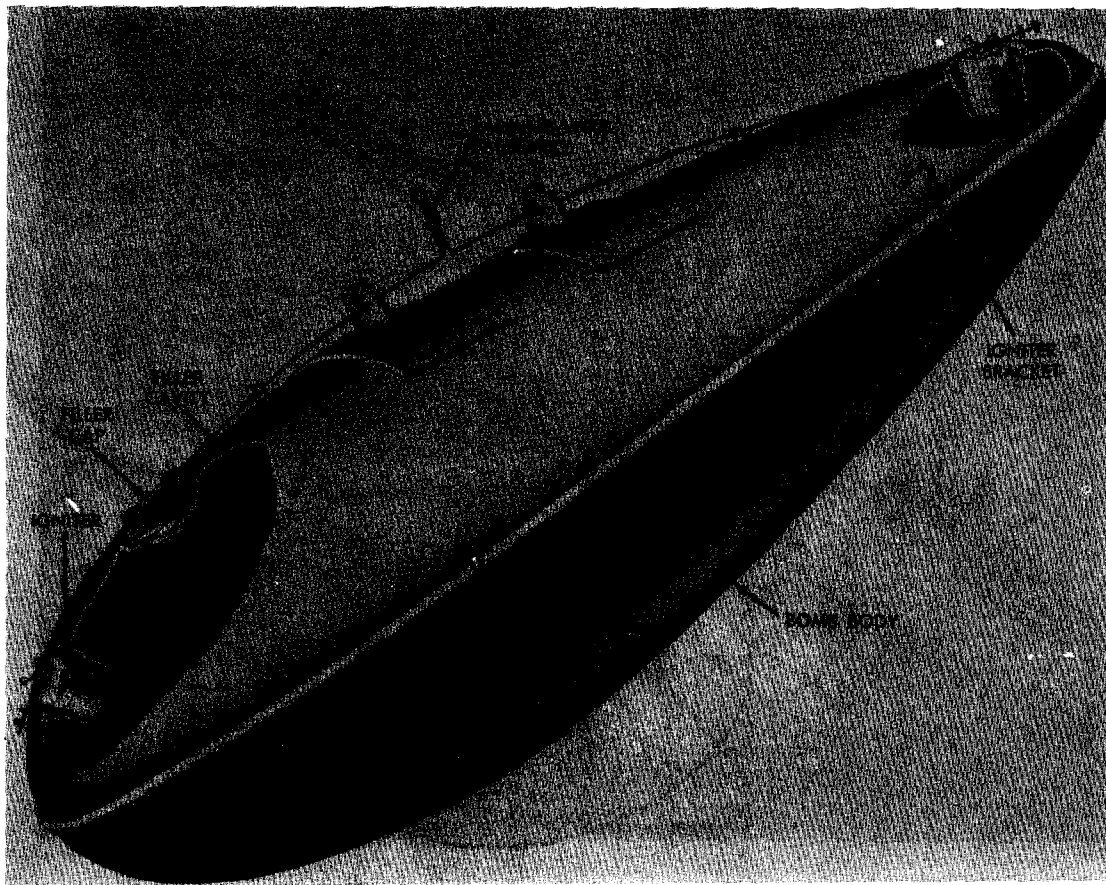

Fig 2-13 750-lb FIRE BOMB, Mk78Mod2

to 750-lb bombs, except that it is smaller in size (18.73 inches in diam & 108.6-in length) and contains only 450-lb of gelled fuel. Same fuzes and igniters as above are used (Ref 51a, pp 2-47 & 2-48)

750-lb Fire Bomb Mk78Mod2k consists of two sheet-steel half-shells welded together to form a body of different shape (See Fig 2-13) than shown of Fig 2-12. Its diam in the widest section is 26.4-in, total length 89.12-in, total wt 760-lb and wt of gasoline gel filler 660-lb. Same fuzes and igniters as above are used (Ref 51a, pp 2-49 & 2-50)

1000-lb Fire Bomb, Mk79Mod1 is a fin-stabilized low-drag bomb with body constructed of thin metal in four sections (See Fig 2-14). Its diam is 19.6-in, total length 167.7, total

wt 912-lb with filler (NP + gasoline) 700-lb. Uses fuzes: MkMod0 (with proximity fuze sensing element M20); M173 (with igniter M23 or AN-M23A1); or AN-M173A1 (with igniter AN-M23A1 (Ref 51a, pp 2-51 & 2-52)

750-lb Fire Bomb BLU-1/B and BLU-1B/B are designed for external carriage on high performance aircraft with forced-ejection release systems. They are constructed of Al with reinforced areas for sway bracing and aircraft forced ejection. The bomb body consists of three sections: The nose, center, and tail which are nested with supplemental components to obtain a high density package (See Fig 2-15)

Unlike earlier types of fire bombs, the BLU-1/B utilizes electrically-armed impact fuzes which require a cable assembly to

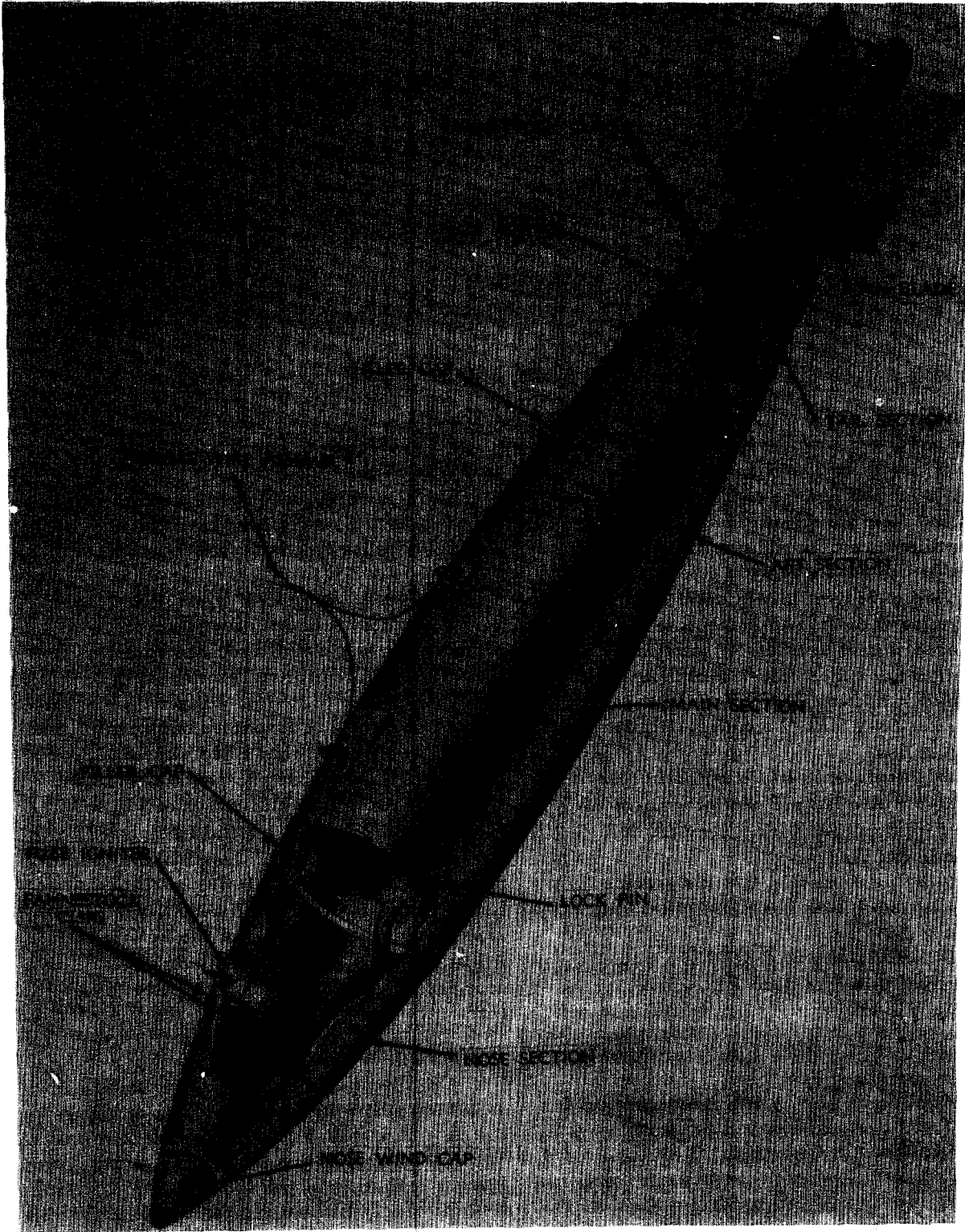

Fig 2-14 1000-lb FIRE BOMB, Mk79 Mod 1

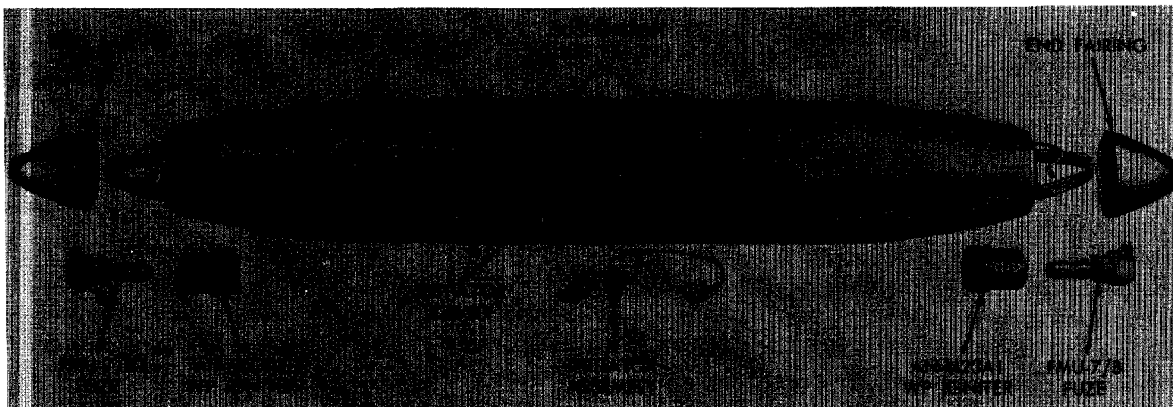

Fig 2-15 FIRE BOMB, BLU SERIES
(Components)

utilize power generated by a thermal battery in the initiator. End caps are used in the BLU-1/B instead of nose caps and tail cones and there are significant overall and weight differences. In addition the fuze system has an arming delay of 0.3 to 7.1 sec. Diam of body is 18.5-in, total length 130.0, total wt 697 to 873-lb (depending on filler used) and wt of filler (NP or other) 615 to 790-lb. Fuzes FMU-7/B or FMU-7A/B (2 required); initiator FMU-7/B or FMU-7A/B; and igniter AN-M23A1 (2 required) (Ref 51a, pp 2-53 & 2-54)

250-lb Fire Bombs BLU-10/B, BLU-10A/B and 500-lb BLU-23/B are smaller versions of 750-lb Fire Bomb BLU-1/B. They are described in Ref 51a, p 2-54

750-lb Fire Bomb BLU-27/B is a welded version of 750-lb Fire Bomb 1B/B (Ref 51a, pp 2-54 & 2-55)

500-lb Fire Bomb BLU-32/B is a welded version of 500-lb Fire Bomb BLU-23/B (Ref 51a, p 2-55)

Section 6, Part A

g) Smoke Bombs

Definition of smoke bombs is given in Ref 44, p B229-L, under Bombs, Chemical The following type is described in Ref 51a, pp 2-56 & 2-57:

100-lb Smoke Bomb PWP or WP, AN-M47A4. Its body, made of sheet steel is cylindrical in shape with a rounded nose and a truncated conical tail section containing fixed tail fin (See Fig 2-16). Diameter of body 8.0-in, length of assembled bomb 52.6; in, total wt 105.0-lb [when filled with 74.0-lb of PWP (plastic white phosphorus)], or 131.0-lb (when filled with 100.0-lb of WP). A burster well, which is a metal tube closed at one end, extends the full length of the bomb, is filled with an explosive. For the bomb filled with PWP the Burster AN-M20 is used, while for the WP bomb the Burster AN-M18 is used. A threaded hole in the nose end of the bomb receives the AN-M159 fuze or its alternate AN-M126A1. Two

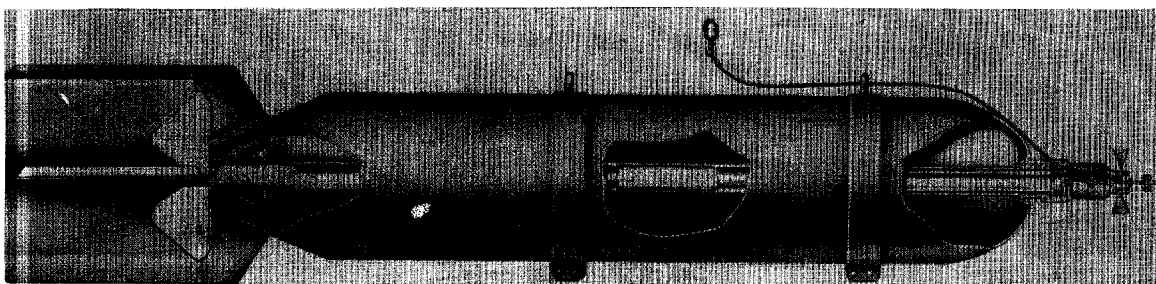

Fig 2-16 100-lb PWP (or WP) SMOKE BOMB,
AN-M47A4

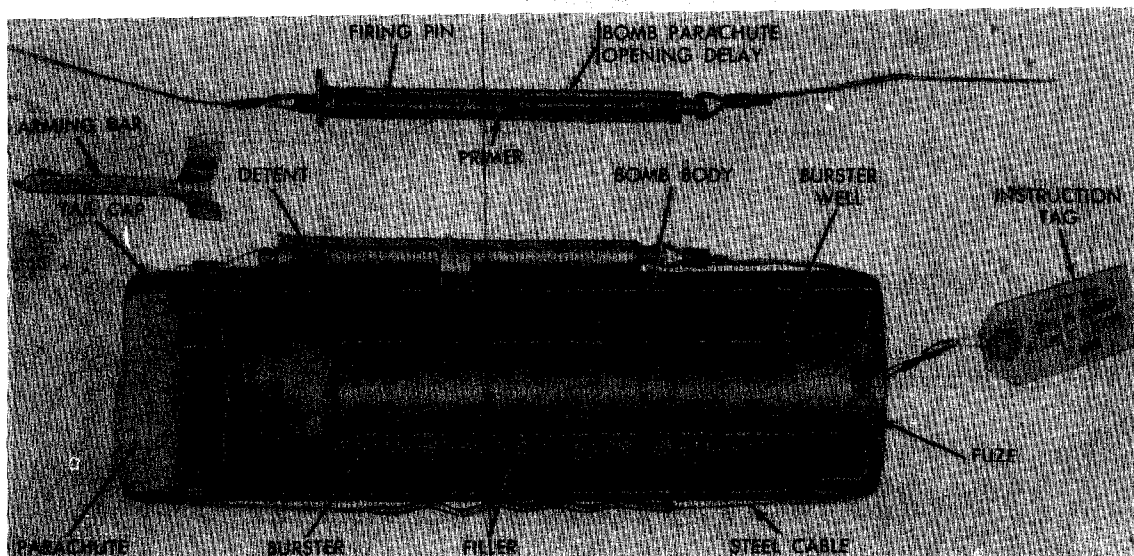

Fig 2-17 10-lb GB NONPERSISTENT
GAS BOMB, M125A1

suspension bands with suspension lugs at the top are clamped around the body by screws. When the bomb hits a target, the fuze explodes the contents of burster. This shatters the bomb and causes dispersion of PWP (or WP) filler and its ignition on contact with air

Section 6, Part A

h) Gas Bombs (Nonpersistent and Persistent)

Definition of gas bombs is given in Ref 44, p B229, under Bombs, Chemical

The following bombs are described in Ref 51a, pp 2-58 to 2-64: 10-lb M125A1, 500-lb Mk94Mod0, and 750-lb MC-1. All of them are filled with "nonpersistent" gas GB described in Ref 44, p C167-R under CHEMICAL AGENTS

10-lb Gas Bomb, M125A1 (Fig 2-17) is cylindrical in shape, provided with the burster M31 (filled with 250 grams of Teteryl), and fuze M196. Its diam is 3.63-in, length (including parachute assembly) 12.0-in and wt 8.5-lb (including 2.6-lb of GP filler. When the bomb is released from the cluster, the arming bar springs away from the parachute opening delay, and the firing pin in

the delay fires the primer of parachute-opening mechanism. The primer ignites the delay chge, which after burning for 3 to 7 secs sets-off the expl chge of parachute-opening delay. The expln breaks the stranded steel cable, freeing the tail cup and removing restraint from the fuze arming ring. The parachute opens and abruptly slows the descent of the bomb. The rapid deceleration causes the arming ring to fall from the fuze, thus arming it. When the bomb impacts the fuze initiates the burster which ruptures the body and releases the bomb filler (Ref 51a, pp 2-58 & 2-59)

10-lb Gas Bomb, Incapacitating BZ, M138 is a thermal generation munition consisting of 4 canisters nested in a tubular steel bomb casing which has been crimped to hold the canisters in place. The canisters contg the BZ chemical warfare agent are aligned within the casing. Each bomb is fitted with fuze M150A2 (not listed in Ref 51a), which is a direct arming pin type (Ref 51a, p 3-15) (See also under Cluster, Bomb: Incapacitating, BZ, 750-lb M43)

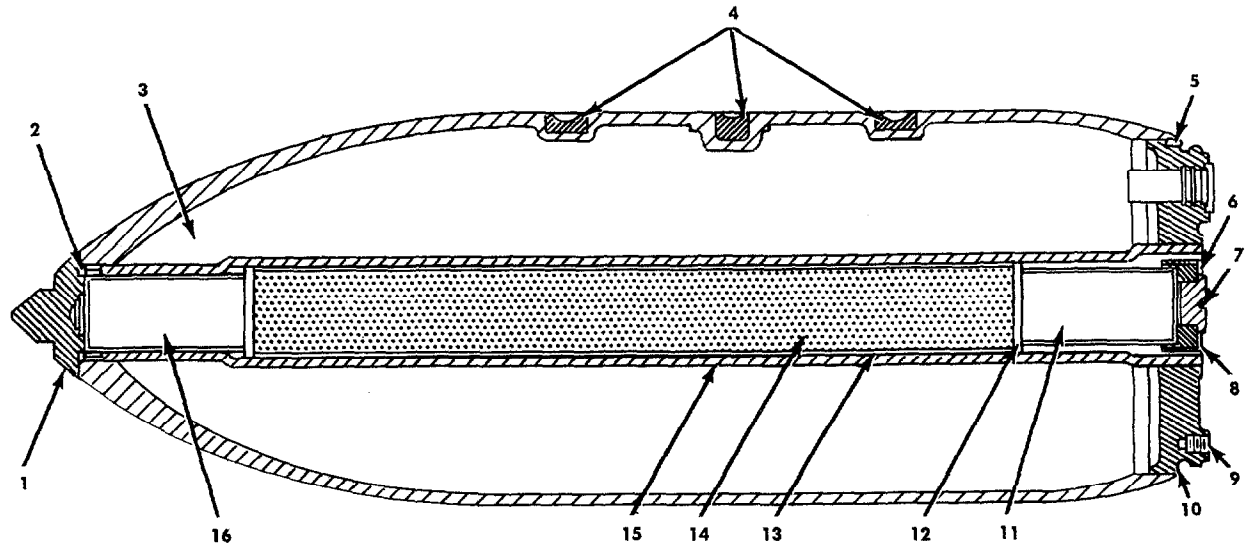

- | | | |
|--------------------------|-----------------|----------------------------|
| 1 Noseplug | 7 Closing plug | 12 End cap |
| 2 Gasket | 8 Retainer ring | 13 Burster |
| 3 Filler (GB) | 9 Threaded hole | 14 Composition B explosive |
| 4 Suspension lug inserts | 10 Baseplate | 15 Burster tube |
| 5 Alignment pin | 11 Fuze well | 16 Fuze well |
| 6 Plug bushing | | |

Fig 2-18 750-lb GB NONPERSISTENT
GAS BOMB MC-1

500-lb Gas Bomb Mk94Mod0 is essentially an Mk82Mod1, GP Low-Drag Bomb (shown here on Fig 2-6), which has been modified for liquid GB filling. The modification consists largely in the elimination of the electric cable conduits from GP bomb, and the addition of a burster (contg 16.1-lb HBX-1), and filler hole. Body diam 10.8-in, overall length 88.8-in, and total wt 441.0-lb, which includes 108.0 GB filler. It can use one of the 11 types of nose fuzes (including 3 types of VT fuzes) and one tail fuze AN-M195. For all fuzes other than VT, only nondelay is used (Ref 51a, pp 2-60 & 2-61)

750-lb Gas Bomb MC-1 is essentially a 750-lb GP New Series M117 (shown here on Fig 2-5), which has been modified to accommodate liquid GP filling and a burster, M filled with 14.5-lb of CompB. Diam of body 16.0-in, overall length 90.10-in, total wt 725.0-lb, which includes 220.0-lb GP

filling. It can use one of the eight nose fuzes and tail fuzes M190 or M905. All fuzes are set for nondelay action because they are supposed to detonate on impact of bomb. Cutaway view of bomb, except its tail section is shown here on Fig 2-18 (Ref 51a, pp 2-62 & 2-63)

Section 6, Part A

i) Aircraft Depth Bombs (ADB)

A brief description and a poorly reproduced Fig of 650-lb bomb are given in Ref 44, p B228-R. The following depth bomb is described in Ref 51a, pp 2-66 to 2-69

350-lb ADB, AN-Mk54Mod1 is cylindrical in shape resembling in appearance the 650-lb bomb shown on Fig of Ref 44, p B228-R. Body diam 13.5-in, overall length 54.6-in and wt 323.8-lb (when loaded with 225.5-lb of TNT) or 346.3-lb (when loaded

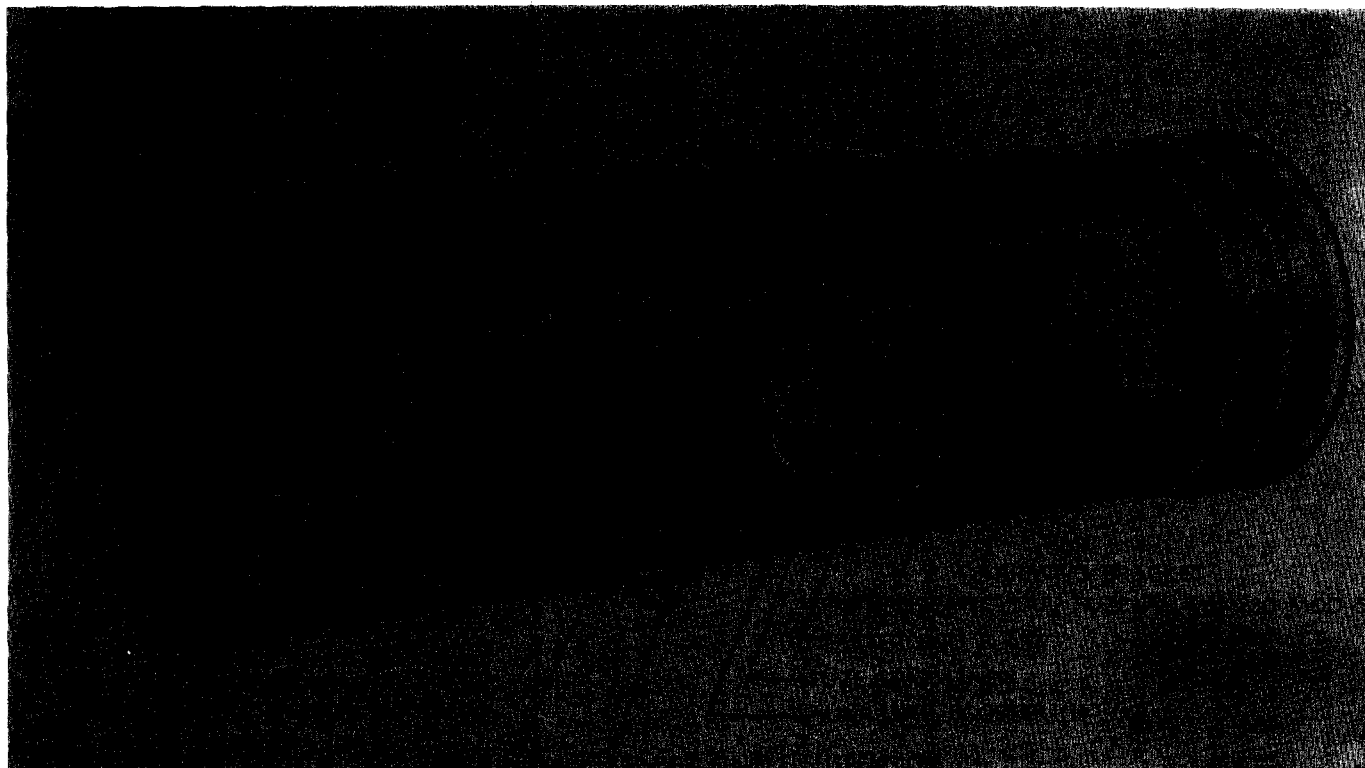

Fig 2-19 350-lb DEPTH BOMB, AN-Mk54Mod1

with 248.0-lb of HBX or HBX-1). The depth of detonation is determined by the setting of the hydrostatic tail fuze, such as AN-Mk230 Series (shown here on Fig 4-22), when the bomb is used against the submarines. The bomb may also be equipped with a nose fuze AN-M103A1 (shown here on Fig 4-1) that functions with instantaneous action, when used against surface ships or land targets. Cutaway view of this depth bomb is given on Fig 2-19, which is taken from Ref 19b, p 46. A similar Fig but not as detailed is given in Ref 51a, p 2-69

Section 6, Part A

j) Leaflet Bombs

A brief description and poorly reproduced Fig are given in Ref 44, p B229-R. A more streamlined in shape bomb, 750-lb M129E1, is described in Ref 51a, p 2-70. The bomb is an aimable-cluster type similar in appearance to the 750-lb GP, New Series Bomb

shown here on Fig 2-5. Diam is 16.0-in, overall length 90.0-in and wt of bomb without leaflets 92.0-lb. It uses nose fuze AN-M147A1 or M909 (with nose vane T5A2. Its cutaway view is given in Ref 51a, p 2-71, Fig 2-51 (Not reproduced here)

Section 6, Part A

k₁) Pyrotechnic Bombs (Photoflash)

Although many pyrotechnic items, such as flares, aircraft signals, simulators and photoflash bombs are released from aircraft and are actually bombs, only photoflash bombs are classified as bombs and stored with bombs and not with pyrotechnic items. The reason for this is that the filling of photoflash bombs is explosive and such bombs are hazardous to handle. Another reason is that they resemble in appearance conventional aircraft bombs

A brief definition of photoflash bombs is given in Vol 2 of Encycl (Ref 44), p B229-R

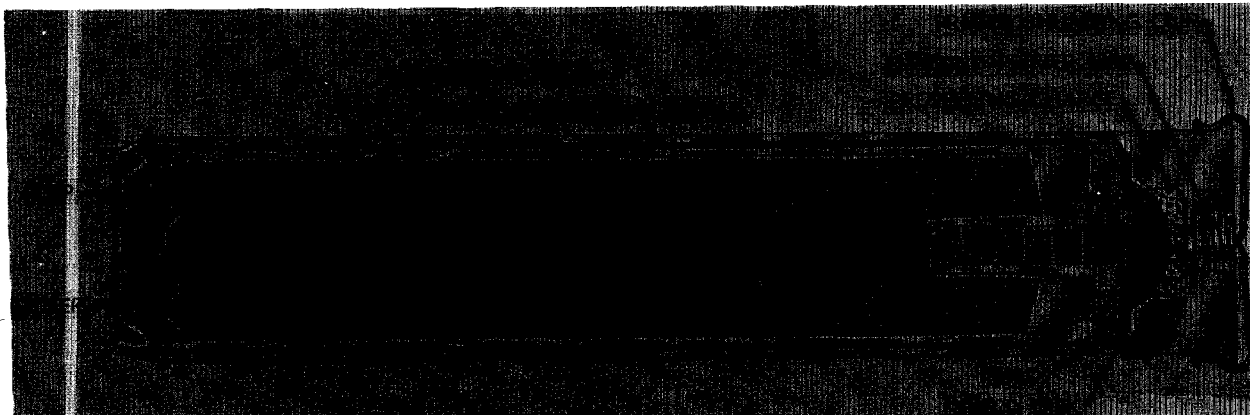

Fig 2-20 PHOTOFLASH CARTRIDGE, M112A1
(1, 2 & 4-Second Delay)

Description of the following photoflash cartridges is given in TM 9-1370-200 (1966) (Ref 51c, pp 2-1 to 2-7)

Photoflash Cartridges, M112A1 (1, 2 or 4-Second Delays). Each consists of a cylindrical Al container (1.57-inches in diam & 7.73-in long), filled with photoflash powder (7.0-oz), a delay fuse contg gasless Ba chromate & boron compn and an electric

primer with a small propelling chge (See Fig 2-20). When fired, the cartridge produces after 1, 2 or 4-sec delay a flash having a peak candlepower of 100 million during the first 0.04 second (Ref 51c, pp 2-1 to 2-3)

Photoflash Cartridges M123A1 (2-Seconds Delay) consists of an Al cylinder 2.885-inches in diam & 8.450-in long filled with 1.75-lb photoflash compn and containing a delay

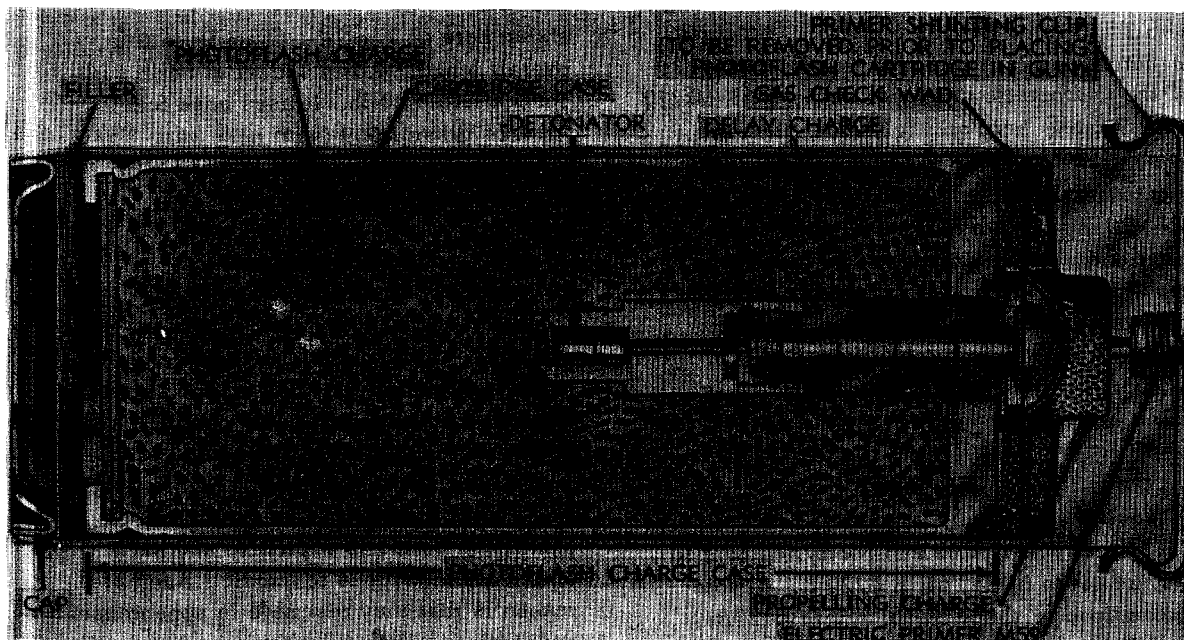

Fig 2-21 PHOTOFLASH CARTRIDGE, M123A1
(2-Second Delay)



Fig 2-22 PHOTOFLASH CARTRIDGE, M123A1
(4-Second Delay)

fuse, an electric primer and a small propelling charge (See Fig 2-21). Its operation is the same as that of M112A1

Slightly different in appearance is the M123A1, 4-Second Delay Cartridge (See Fig 2-22) (Ref 51c, pp 2-3 to 2-5)

Photoflash Cartridge M121, used for practice, is filled with dummy charge. It simulates M112A1 series (Ref 51c, pp 2-4 & 2-6)

Photoflash Cartridge M124, used for practice, is filled with inert charge. It simulates M123A1 series (Ref 51c, pp 2-6 & 2-7)

The following photoflash bombs are described in TM 9-1325-200 (1966) (Ref 51a, pp 2-71 to 2-73):

100-lb Photoflash Bomb, M122, shown on Fig 2-23, consists of round-nosed cylindrical body, 8.0-inches in diameter, with the fin assembly M125A1 attached. Total length 50.0-in and total wt 107.0-lb of which 75.0-lb is photoflash powder developing on burning a peak intensity (candlepower) of 26 million. A burster tube extends from the nose fuze well to the base plug. Its nose

fuze is M147A1 or M909 with nose vane T5A2. Upon impact with the target, the fuze initiates expl chge of the burster and this bursts the bomb body and ignites the photoflash powder (Ref 51a, pp 2-71 & 2-72)

150-lb Photoflash Bomb M120A1, which is modification of M120 Bomb, is similar in appearance to 100-lb M122 bomb, except that its nose looks different because it is provided with a "spoiler ring". Its tail assembly is provided with a "drag plate" which is used when a trajectory angle other than that produced by the normal fin is desired. Diam of body is 10.6-in, overall length 55.8-in, and total wt 168.0-lb, which includes 82.0-lb of photoflash powder developing on burning a peak intensity of 4.4 billion candlepower (vs 3.4 billion for M120), with an average light output of 9.2 million candlepower-seconds in the first 0.04 sec at altitudes up to 43000 ft. It uses the same types of bursters and fuzes as M122 bomb (Ref 51a, pp 2-72 & 2-73)

k2) **Pyrotechnic Bombs (Aircraft Flares)**

Although flares are not classed as bombs, we are including them because some



Fig 2-23 100-lb PHOTOFLASH BOMB, M122

of them are similar in appearance to conventional bombs and because they are released from aircraft in the same manner as bombs

Aircraft flares serve to provide illumination for target marker, battlefield visibility, reconnaissance, observation, bombardment,

landing and practice firing for AA guns

There are many types of aircraft flares judging by their description given in Ref 51c, pp 3-1 to 3-44

We are giving here one typical example of a flare, which resembles more than other flares a conventional bomb:

Fig 2-24 AIRCRAFT PARACHUTE FLARE,
M26A1 (AN-M26)

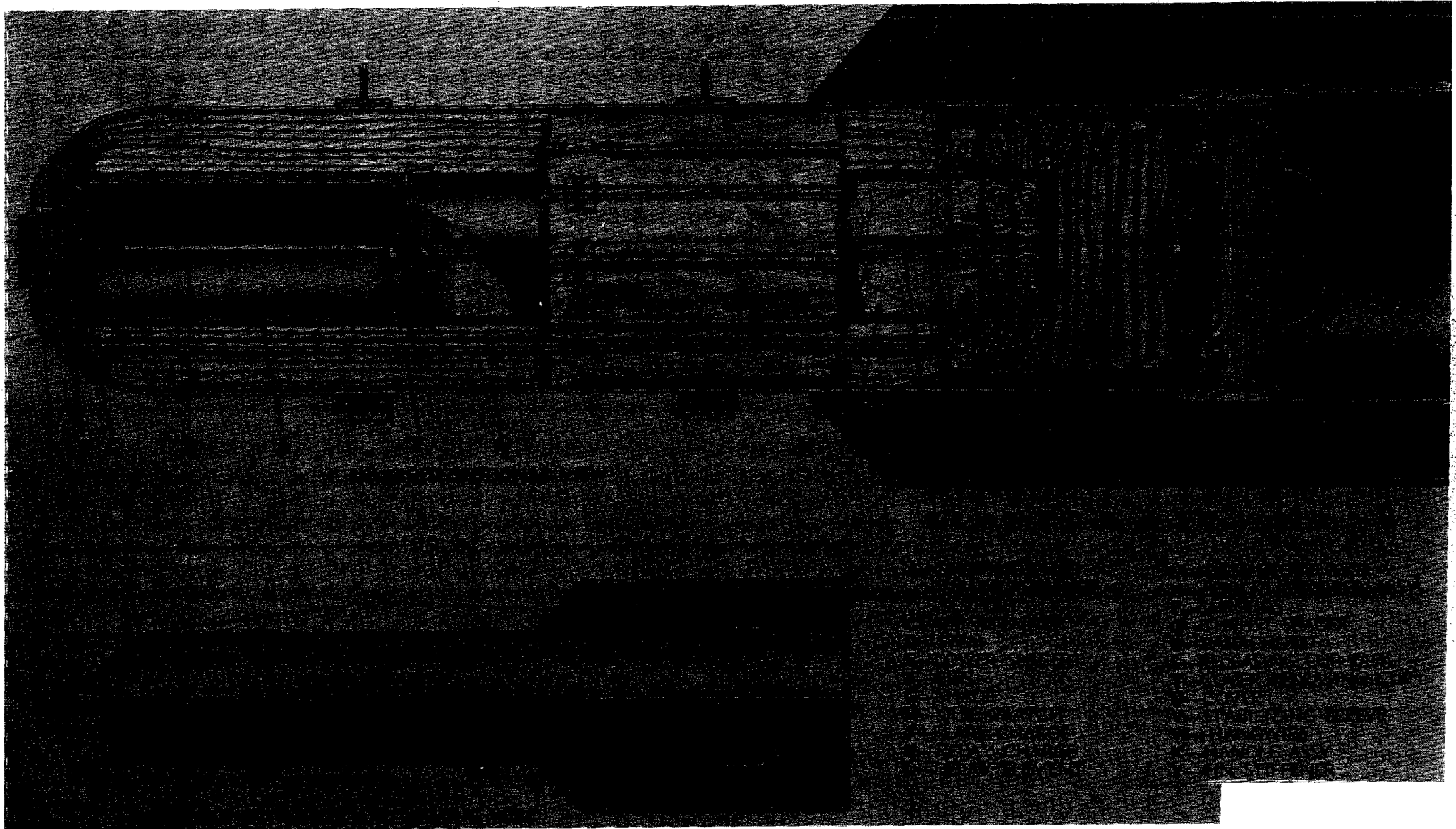

Aircraft Parachute Flare, M26A1, shown on Figs 2-24 & 2-25, is intended for illumination in night bombardment. It is parachute-supported type which burns with a yellowish light and casts circular usable illumination upon the terrain 1500 feet in diam. By use of an MT fuze of the Mill Series the flare may be released from altitudes 2500 to 25000 feet at 350 mph true air speed

The flare case (See Fig 2-24) is cylindrical with rounded nose and four fins attached to the rear third of its length. The flare case is equipped with two lugs for horizontal suspension, the rear lug being positioned at the center of gravity. A cylindrical fin stiffener (Y) is bolted to the rear end of the fins. Underneath the shipping cover and handle assembly (X) is the hangwire (W) in its cup-like container. The inside end of the hangwire is held in position below the hangwire container by a hangwire stop and soldered bent end, both in side indents of container. Midway between the hangwire stop and soldered end is attached a tear wire cord of the stabilizing sleeve (V) which is located immediately below the hangwire container. The stabilizing sleeve consists of a conical inner sleeve to which is sewed a shorter but wider sleeve along four longitudinal seams. Four shrouds are sewn to the inner sleeve of the stabilizing sleeve. A detachable cover lock cord is attached to two diagonally opposite sleeve shrouds. This detachable lock cord is tied to the detachable lock, which is a safety device to prevent accidental pull out of the cover releasing cup (T) from the detachable cover (U), which is held in place by four retaining pins. A spring on each pin acts to press the back of the pin against the periphery of the cover releasing cup; each pin engages a groove in the flare case. The cover releasing cup fits down thru the center of the detachable cover and is held in place by three tabs. A pull-out cord eye is set in the base of the cover releasing cup (T). Below (T) is a releasing cup disc (S) which has an eyelet in its center. The parachute pull-out cord passes thru this eyelet and is fastened to the cover releasing cup eye.

The 14.5-foot diameter parachute (R) and its shrouds (P) are immediately below the releasing cup disc (S) and a parachute cover. A cylindrical thrust spacer (Q) surrounds the parachute assembly and is divided axially into two halves. The flare is initiated by pulling a cord thru friction igniter (not shown on Fig 2-24); the resulting flash ignites the delay element (L) in the central tube of the illuminant assembly which burns ca 5.5 secs. The flame is then transmitted by a relay charge (K) to the quickmatch (H), first-fire charge (not shown on Fig 2-24), and the 17.7-lb flare charge. Diam of the chge is 3.82-inches. A closing cover assembly for the illuminant assembly has a socket with cotter pin holes for receiving the head of the steel stem (D), the other end of which is bolted to the rib retainer (C). A hollow cylindrical lower spacer (E) rests between the illuminant chge and the rib retainer. The shade assembly (intended to shield the bombardier from the glare) consists of an asbestos or Fiberglas shade (G), shade wire, 8 steel tubing ribs (F) & springs, and a shade frame clamped to the base block end of the illuminant assembly. A shade retainer support (B) into which a steel fuze adapter and its plastic shipping plug (A) fits, completes the flare assembly

The flare can be launched from bomb shackles, from shackles mounted in bomb bays, or from launcher tubes. It should not be released manually except in emergency

The flare may be released "safe" or "armed". If released safe, it may function on impact. If released armed the flare functions as follows: (See Fig 2-25)

The movement downward withdraws the arming wire (A) from the fuze, allowing the vane to rotate to arm the fuze and, at the same time, allowing the arming pin to be ejected, thus starting the time mechanism

When the flare has dropped the length of the hangwire (B), the latter breaks the seal wire and pulls out the hangwire cover (C), which drops free. The tear-wire (D), which is attached to the hangwire, pulls out the tear-wire cord which, in turn, pulls out the stabilizing sleeve (E) and its shrouds.

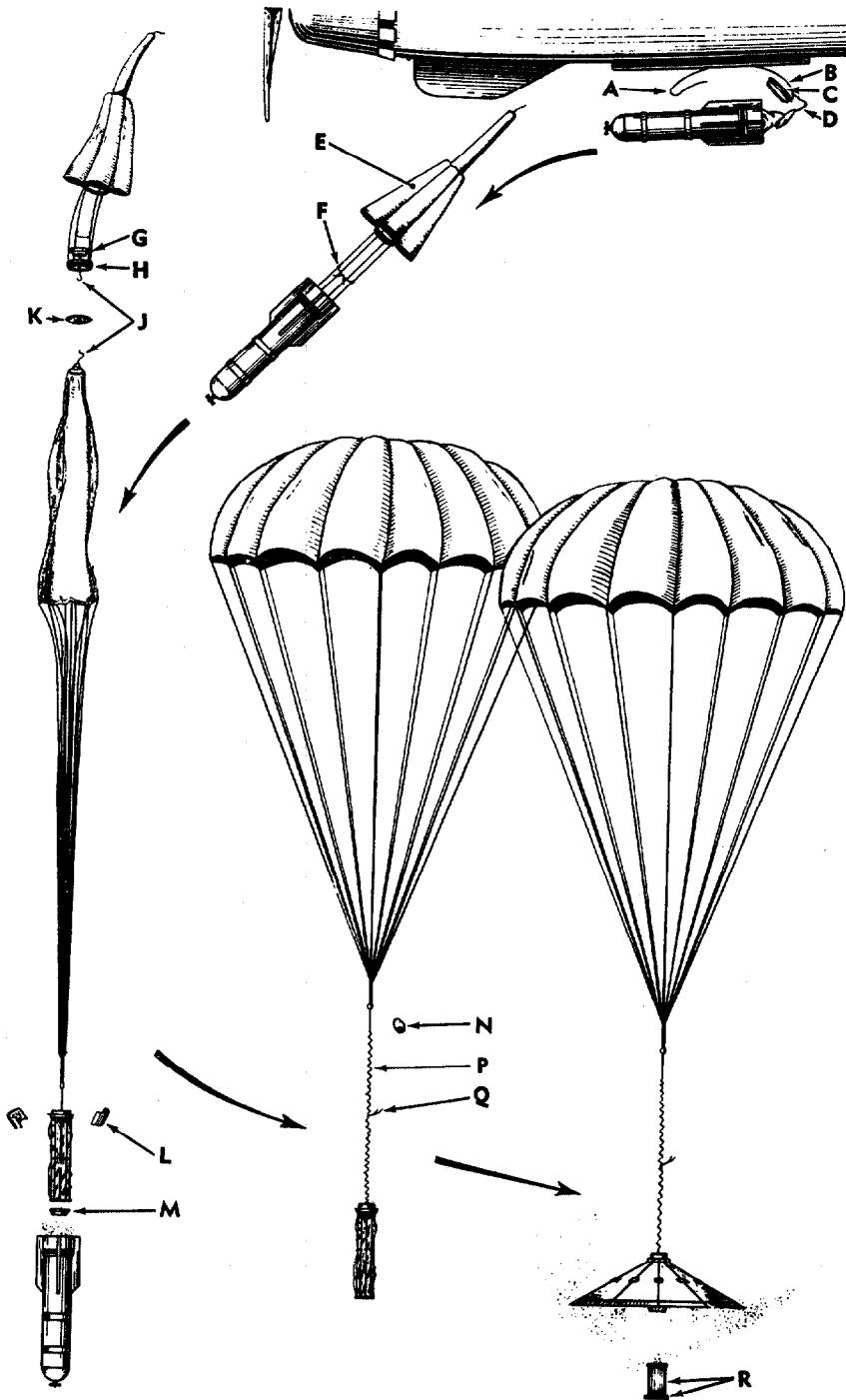

A—ARMING WIRE
 B—HANGWIRE
 C—COVER
 D—TEAR WIRE
 E—SLEEVE
 F—DETACHABLE COVER LOCK
 G—COVER RELEASING CUP
 H—DETACHABLE COVER

J—PULL OUT CORD
 K—RELEASING CUP DISK
 L—THRUST SPACER
 M—SHADE RETAINER SUPPORT
 N—SAFETY DISK
 P—SHOCK ABSORBER
 Q—FRICTION WIRES OF IGNITER
 R—LOWER SPACER AND RIB RETAINER

Fig 2-25 AIRCRAFT PARACHUTE FLARE,
 M26A1 (AN-M26) (Operation)

The detachable cover lock cord, attached to the shrouds, removes the lock (F) of the cover releasing cup (G)

When the flare has dropped the combined length of the hangwire, tear-wire, tear-wire cord, sleeve, and shrouds, its momentum breaks the tear-wire, allowing the flare to drop. It is stabilized in flight by its fins and sleeve. The arming vane on the fuze rotates to arm the fuze a maximum of 3 seconds after release when released at speeds of 200 mph or higher

At the time set, the fuze functions to push out the cover releasing cup (G) by means of the gases produced. The four retaining pins of the detachable cover (H) move back to permit the expulsion of the detachable cover to which the stabilizing sleeve shrouds are attached. At the same time, the parachute pull-out cord (J) (attached to the cover releasing cup nested in the detachable cover) and the expanding gases from exploded expelling charge of the fuze force the parachute and shade and illuminant assembly from the case, which falls free. The thrust spacer (L) and shade retainer support (M), no longer restrained, also fall away free

The parachute opens not more than 5 seconds after illuminant and shade assembly are expelled from the outer case. The fall of the flare is retarded with a jerk which:

Breaks the parachute pull-out cord, allowing the stabilizing sleeve (E), cover releasing cup (G), and detachable cover (H) to be separated from the flare and to fall free; and

Straightens out the coiled shock absorbers (P), which results in pulling the friction wires (Q) thru the igniting mixture, thus starting the ignition train of delay element, relay charge, quickmatch, first-fire charge, and flare charge. Full ignition is delayed for at least 6 seconds to insure complete opening of the parachute before the candle burns

As the flare charge ignites, the gases generated expel the lower spacer and rib retainer (R), allowing the rib springs to open

the shade. Full ignition is reached in ca 8 secs (but not more than 11 secs), after initiation of ignition begins (Ref 51c, pp 3-6.1 and 3-8 to 3-12)

Other aircraft flares described in Ref 51c, pp 3-1 to 3-44 are cylindrical in shape and they include: Flares T6E1, T7E1, T8E1, M8A1, M9A1, M138, M139, Mk5-Series, Mk6-Series, Mk24-Series, AN-Mk8-Series, M78, M79 and Flare Set AN/ALA-17. Of these only T6, T7 & T8 have short cylindrical bodies about equal to their diameters (ca 5.4 inches). All other types consist of cylinders which are 5-6 times as long as their diameters

With the exception of flares T6, T7 & T8 which are intended for use with vertical drop bombs, and flares M78 & M79 which are towed, all other flares described in Ref 51c are provided with parachutes

k3) Pyrotechnic Bombs (Aircraft Signal)

Aircraft signals used directly with combat operations were originally intended for signalling air-to-air or air-to-surface. They have been thrown overboard from aircraft or launched from wing racks. Since the introduction of pyrotechnic pistol AN-M8 and hand pyrotechnic projector M9, aircraft signals have also been used by ground troops

The signals are usually of one piece, cylindrical, rimmed case construction with a steel closing cap. As an example of such signals may be cited:

Aircraft Signal, Illumination, Double-Star, Red-Red, AN-M37A2, which is shown on Fig 2-26. It has a one piece cylindrical Al case (1.57-inches in diam & 3.85-in long), provided with an extracting rim and a primer which is inserted in the base of the case. Two candles of red fire-producing pyrotechnic compn contained in individual Al cases are loaded in the signal case. When fired in the pistol AN-M8 or projector M9, the primer ignites a BkPdr propelling chge, which ignites, in turn, the quickmatch, the 1st-fire compn and the stars. The stars produce 25000 candlepower at full brilliance (Ref 51c, pp 4-1 to 4-3)

Similar in appearance and action are signals AN-M38, 39, 40, 41, 42, 43, 44,



Fig 2-26 AIRCRAFT SIGNAL, ILLUMINATION,
DOUBLE STAR, RED-RED, AN-M37A1

45, 53, 54, 55, 56, 57 and 58-Series (Ref 51c, pp 4-4 to 4-8)

Different in construction and operation is:

Aircraft Signal, Smoke and Illumination, AN-Mk6Mod3, has a square wooden body, (20.25-inches long by 5.13-inches square) with a flat metal nose plate (attached as shown in Fig 2-27) and contg inside four three-unit pyrotechnic candles. A pull-type igniter, covered by adhesive tape, is located in the tail end of the body, where are also located four holes closed by metal caps and sealed with tape. A burning-type delay fuse provides continuity of ignition between the 1.7-oz igniter chge and the top of the first candle and betw the bottom of one candle and the top of the next

Just prior to releasing the flare from the aircraft, the adhesive tape covering the pull-ring is removed and the pull-type igniter is actuated by sharply pulling the ring attached to the friction wire. The resulting flash initiates the delay fuse which, after 90-sec interval, ignites the quickmatch and the first-fire compn of the first candle. As this candle begins to burn, the gas pressure produced forces out the metal cap and adhesive tape seal, allowing the gases to escape and burn. As the first candle burns

down to its end, a fuse is ignited which burns to the top of the next candle unit and this is repeated until all four candle units have burned out (Ref 51c, pp 4-10 to 4-15)

Section 6, Part A

1) Practice Bombs

Their definition is given in Ref 44, p B229-R. The following types are described in Ref 51a, pp 2-74 to 2-93: Miniature, 3-lb Bomb Mk5Mods2 & 3; 5-lb Mk106Mod0; 25-lb Mk76Mod2; 56-lb Mk89Mods0 & 1; 100-lb Mk15Mods2, 3 & 4; 250-lb M124; 500-lb Mk65-Series; 1000-lb Mk66Mod0; 250-lb Mk86Mods0 & 1; 500-lb Mk87Mod0 and 1000-lb Mk88Mod0

Section 6, Part B

Bomb Clusters and Cluster Adapters Definition

To the brief definition of the terms "cluster" and "cluster adapter" given in Ref 48, p C351-L, the following definitions given in Ref 51a, p 3-1 may be added:

"A *bomb cluster* is an assembly of small bombs which may be suspended as a unit in a bomb station designed for a single large bomb. The small bombs are assembled

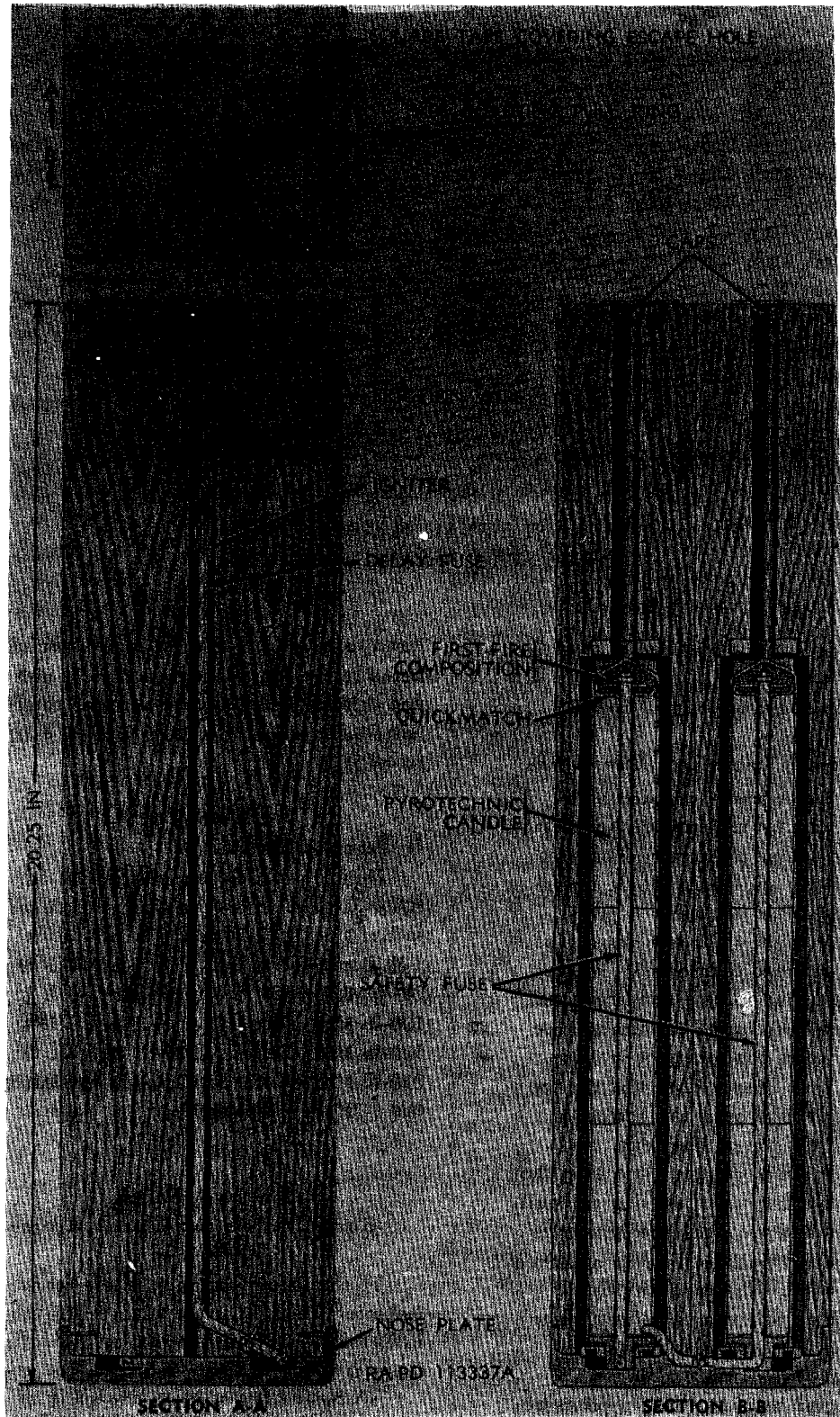

Fig 2-27 AIRCRAFT SIGNAL, SMOKE AND ILLUMINATION, AN-Mk6Mod3

into a single unit by means of a *cluster adapter*. The cluster is released as a unit for area bombing. After release from the aircraft the individual bombs are released from the cluster to arm and fall individually."

The cluster bombs described in Ref 51a, p 3-1 to 3-28 are of two general types, quick-opening and aimable

c) **Quick-Opening (Frame) Fragmentation Bomb Clusters and Adapters.** This type of cluster consists of a frame to which several bombs are attached by means of straps, forming an assembly which may be suspended and released as a unit. The straps are fastened with clamps which may be released by withdrawing the arming wire. The frame is also equipped with a fuze lock which prevents arming of the bomb fuzes until after they are released from the cluster

Section 6, Part B

b) **Aimable Fragmentation Bomb Clusters and Adapters.** This type cluster consists essentially of streamlined metal body which holds the clustered bombs, a fin assembly or other such means of stabilization, and a time fuze to open the body and release the individual bombs at the time desired. This type of cluster can be used for all types of bombs

Note: An "aimable cluster" consisting of a number of incendiary bombs held in a single container is briefly described in Ref 43, p A114-L

100-lb Frag Bomb Cluster, AN-M1A2, shown on Fig 3-1, holds six 20-lb AN-M41A1 frag bombs

The bombs of cluster AN-M1A2 are assembled in *Cluster Adapter AN-M1A3*, shown here on Fig 3-2

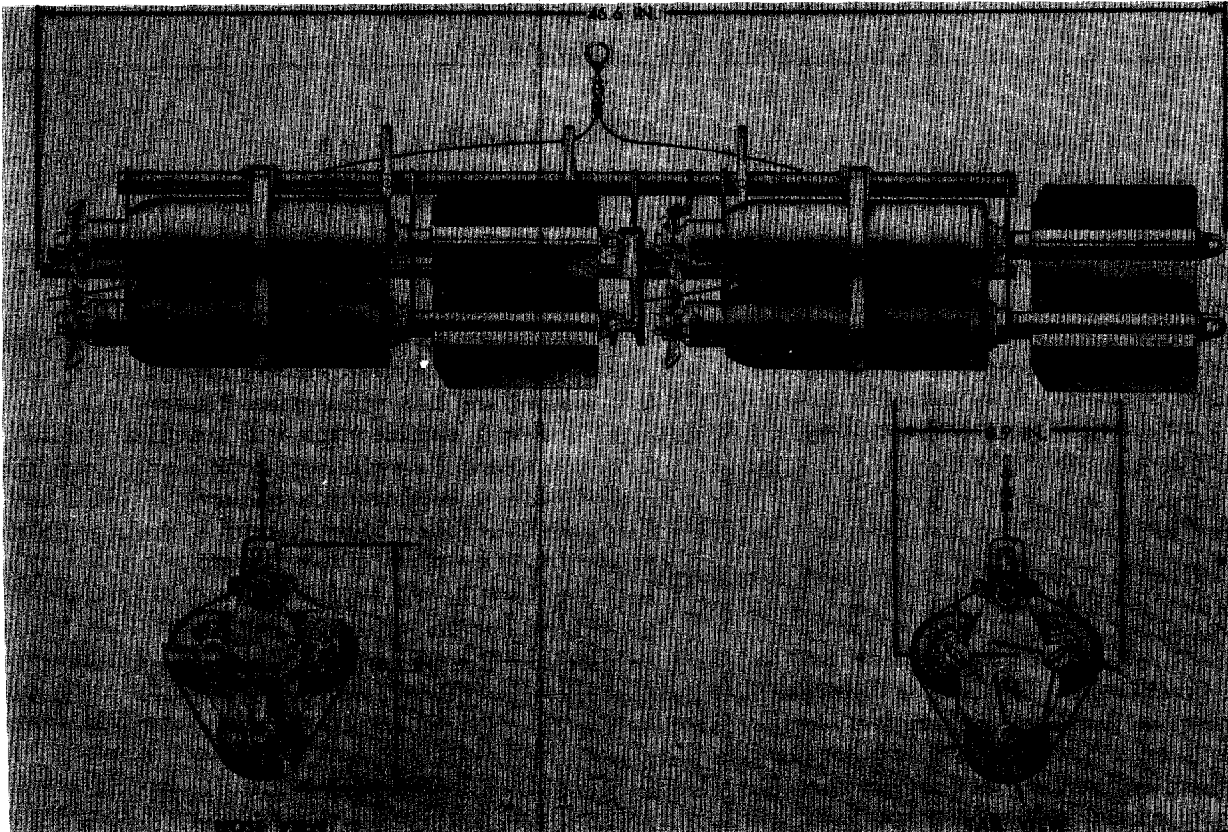

Fig 3-1 100-lb FRAG BOMB CLUSTER, AN-M1A2

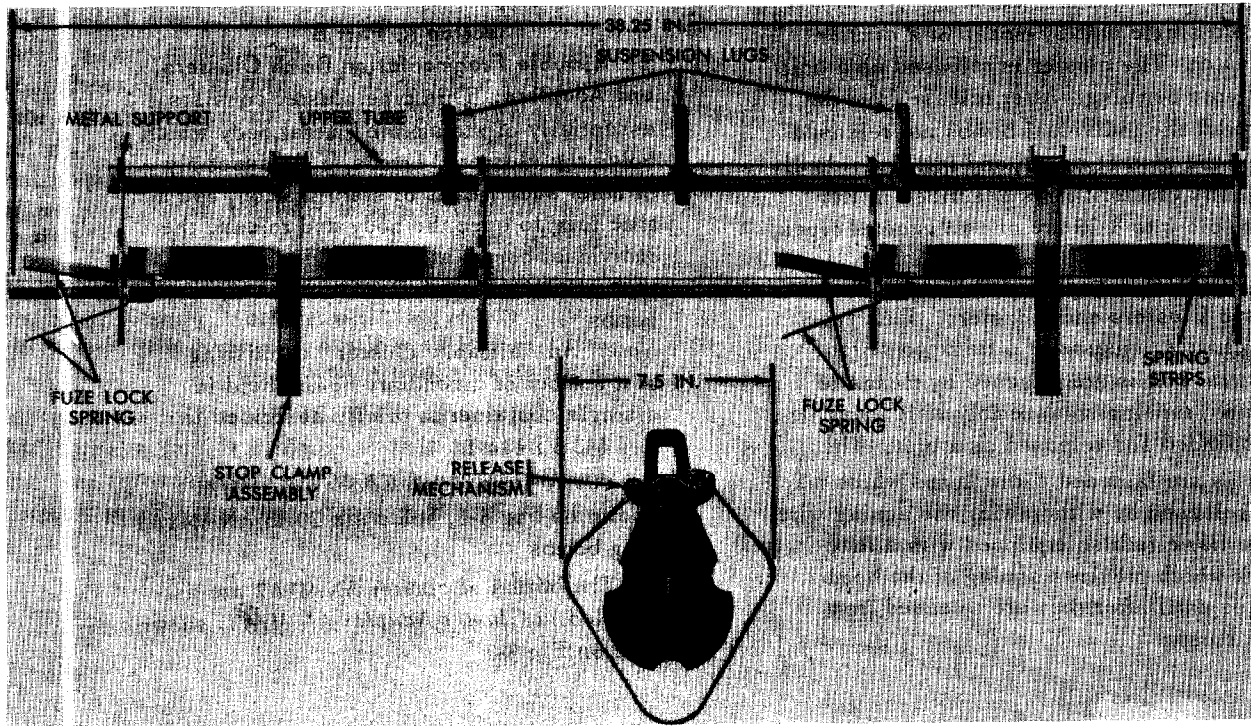

Fig 3-2 CLUSTER-ADAPTER, AN-M1A3

100-lb Frag Bomb Cluster, AN-M4A2 is similar in appearance to AN-M1A2, but holds only three frag bombs, 23-lb M40A1 (Ref 51a, p 3-4)

100-lb Frag Bomb Cluster M28A2, shown on Fig 3-3, consists of 24 4-lb Frag bombs M83 assembled in an aimable-type cluster-adapter M15A2 (described on p 3-6 of Ref 51a). The ensemble is bomb-like in appearance and has a standard fin. It holds the frag bombs (Fig 3-6 of Ref 51a) in eight banks of three each. Loading and dispersal of bombs is accomplished thru a hinged lid on the adapter which is held in place by a nose-locking cup. A spoiler ring is held in place against the nose of the adapter by the nose fuze, and a drag plate is secured to the fin assembly. Two suspension lugs, spaced 14 inches apart, protrude thru slots in the lid section. If single hook suspension is desired, the two lugs are removed from the case and a single lug is attached by four screws to the upper surface of the adapter at the center of gravity (Ref 51a, pp 3-5 to 3-8)

Section 6, Part B

c) Incendiary Bomb Clusters

500-lb PT1 Inc Bomb Cluster, M31, shown on Fig 3-4, consists of cluster adapter M25 filled with 38 10-lb Inc Bombs M74A1, fitted with 3 cluster-ejection cartridges, two fuzes, and an arming wire. When the cluster is released from an aircraft, the arming wire is withdrawn, the fuze arming vanes rotate in the airstream, and the fuzes arm. After the preset time has elapsed, one or both fuzes function and detonate the burster. Concussion from the explosion of the burster depresses the diaphragm in the striker assemblies, driving the points of the strikers into the primers in the cluster-ejection cartridges, exploding the cartridges. Gases released by the cartridges pass thru the gas chamber, thru vent-holes in the chamber, and into the space between the adapter casing base and the pressure plate. Pressure developed by the gases forces the pressure plate toward the nose of the cluster and causes the stud attached to the pressure plate to pull out of the split nut

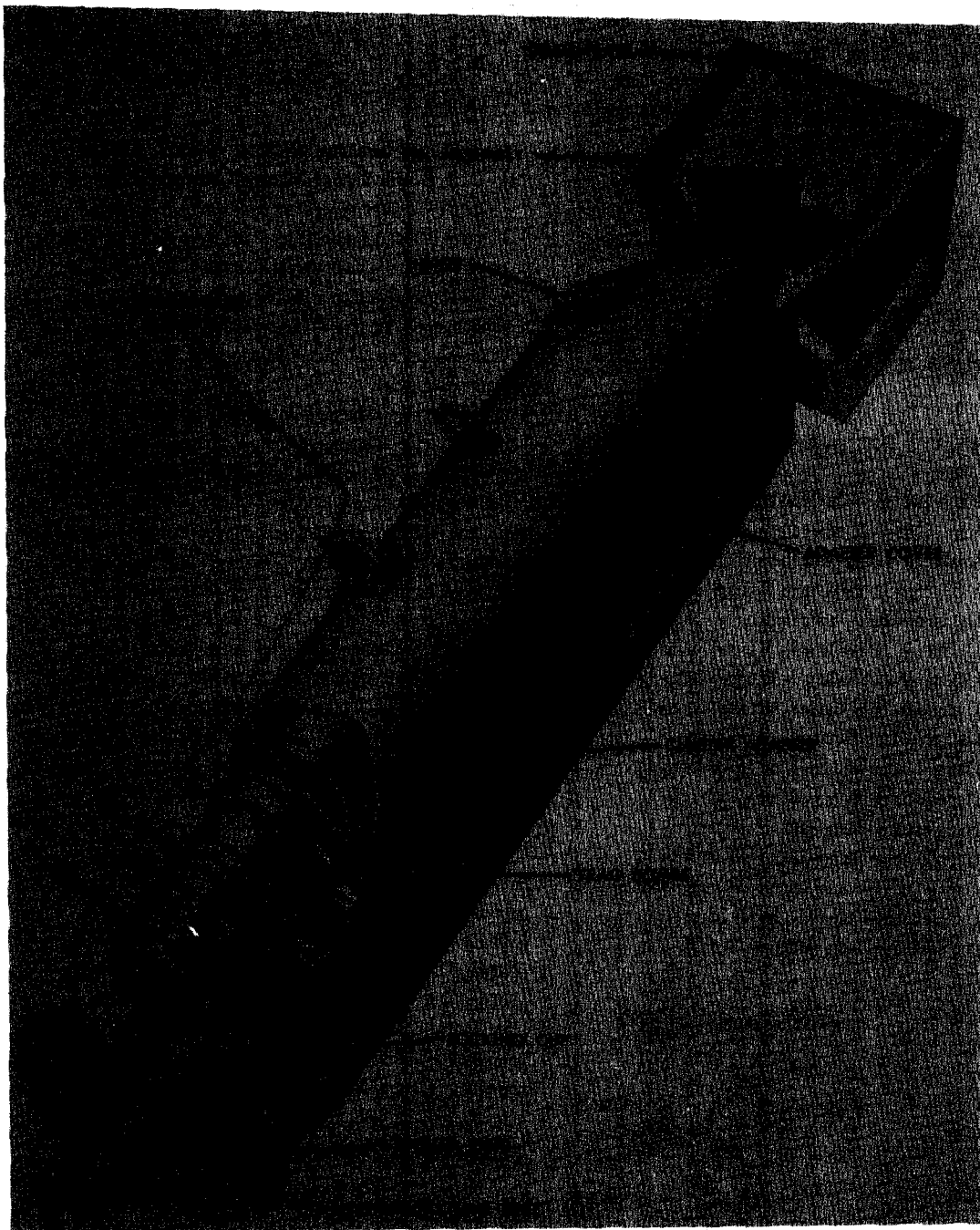

Fig 3-3 100-lb FRAG BOMB CLUSTER, M28A1

which is screwed to the casing base. Continued expansion of the gases frees the nose assembly and forces the framework out of the casing. As each cluster buckle clears the casing, the buckle opens. After all buckles have opened, the adapter frame-

work falls apart, allowing the bombs to fall individually to the target (Ref 51a, p 3-9)

500-lb TH3 Inc Bomb Cluster M32 is a slightly modified version of M31 (Ref 51a, pp 3-9 to 3-10)

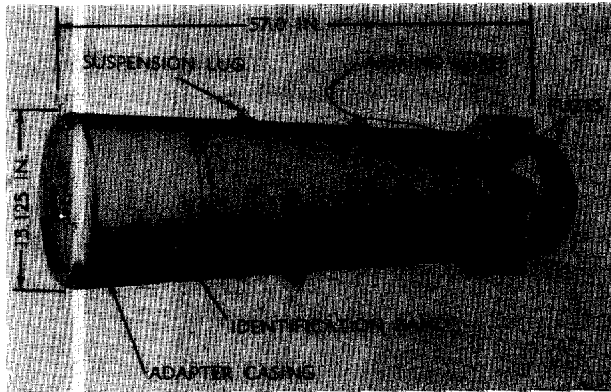

Fig 3-4 500-lb PT1 INC BOMB CLUSTER, M31

750-lb PT1 Inc Bomb Cluster M35, shown on Fig 3-5, consists of cluster-adapter M30 filled with 57 10-lb Inc bombs M74A1 (shown here on Fig 2-10), and fitted with a burster, a fin assembly, two fuzes and an arming wire. When the cluster is released from an aircraft, the arming wire is withdrawn, the fuze arming vanes rotate in the airstream, and the fuzes arm. After the preset time has elapsed, one or both fuzes function and detonate the burster, which breaks the hinges holding the cluster together and breaks the feet and body of the tie-rod assembly. The cluster falls apart, allowing the bomblets to fall individually to the target (Ref 51a, pp 3-11 & 3-12)

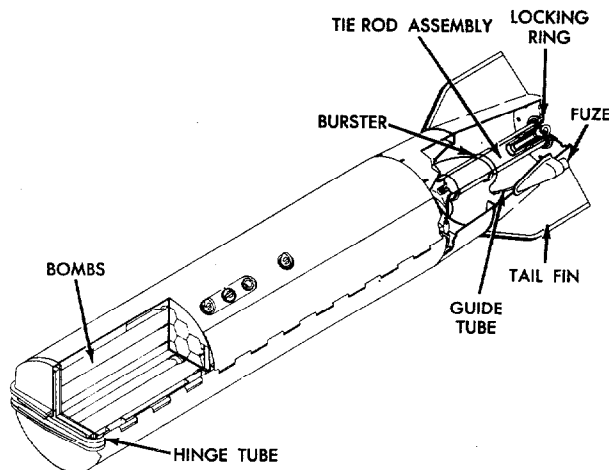

Fig 3-5 750-lb PT1 INC BOMB CLUSTER, M35

750-lb TH3 Inc Bomb Cluster M36 is a slightly modified version of Bomb Cluster M35 (Ref 51a, p 3-13)

Section 6, Part B

d) Gas Bomb Clusters and Adapters

1000-lb GB Nonpersistent Gas Bomb Cluster, M34A1 (or M34), shown on Fig 3-6, consists of cluster adapter M29 filled with 76 10-lb Nonpersistent Gas Bombs M125A1 (shown on Fig 2-17) and fitted with 4 cluster-ejection cartridges, two fuzes, and an arming wire

When the cluster is released from an aircraft, the arming wire is withdrawn, the fuze arming vanes rotate in the airstream, and the fuzes arm. After the preset time has elapsed, one or both fuzes function and detonate the burster. Concussion from the explosion of the burster depresses the diaphragm in the striker assemblies, driving the points of the strikers into the primers in the cluster-ejection cartridges, exploding the cartridges. Gases released by the cartridges pass thru the gas chamber, thru ventholes in the chamber, and into the space between the adapter casing base and the pressure plate. Pressure developed by the gases forces the pressure plate toward the nose of the cluster and causes the stud attached to the pressure plate to pull out of the split nut, which is screwed to the casing base. Continued expansion of the gases frees the nose assembly and forces the framework out of the casing. As each cluster buckle clears the casing, the buckle opens. After all buckles have opened, the adapter framework falls apart, allowing the bombs to fall individually to the target

Cluster M34A1 (or M34) can be converted to its streamlined version (Fig 3-7) to be carried beneath the wing of a bomber (Ref 51a, pp 3-11 & 3-12)

750-lb BZ Incapacitating Gas Bomb Cluster, M43 is similar in construction to M35 Bomb Cluster shown on Fig 3-5. It contains cluster-adapter M30 filled with 19 10-lb BZ Incapacitating Gas Bombs, M138 and fitted with fin assembly, tail fuze, and arming-wire assembly (Ref 51a, p 3-15)

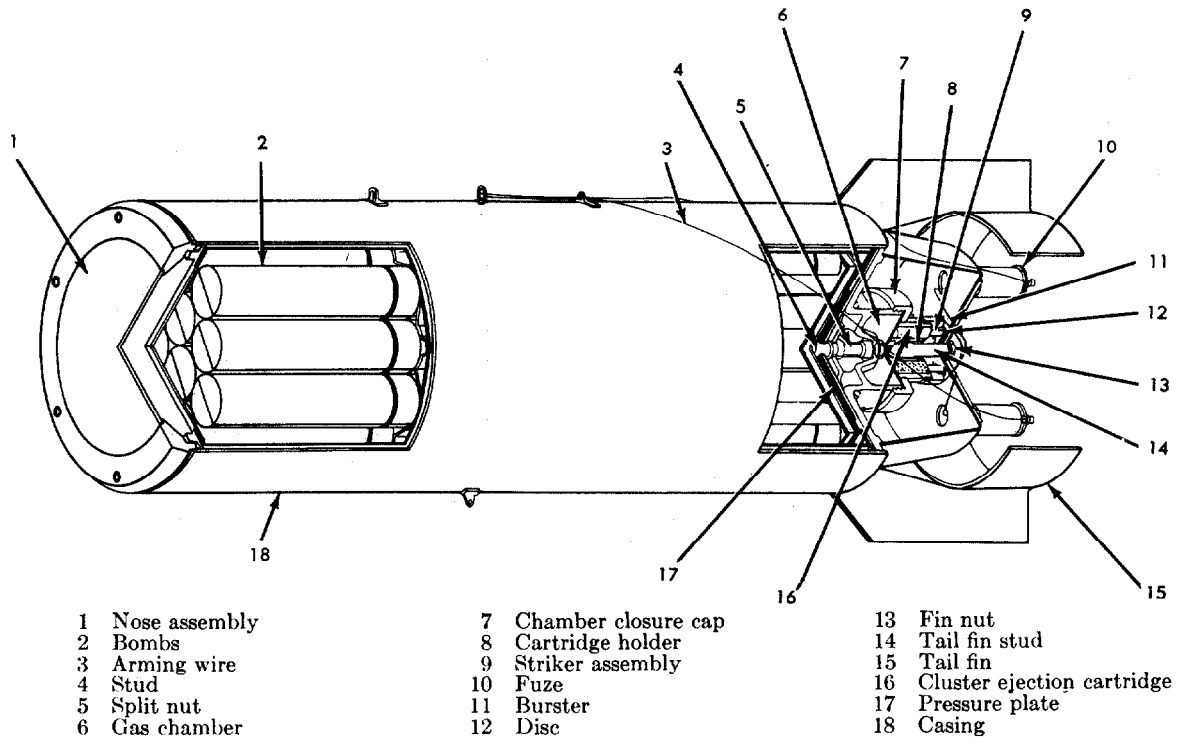

Fig 3-6 1000-lb GB NONPERSISTENT GAS BOMB CLUSTER, M34A1 (or M34)

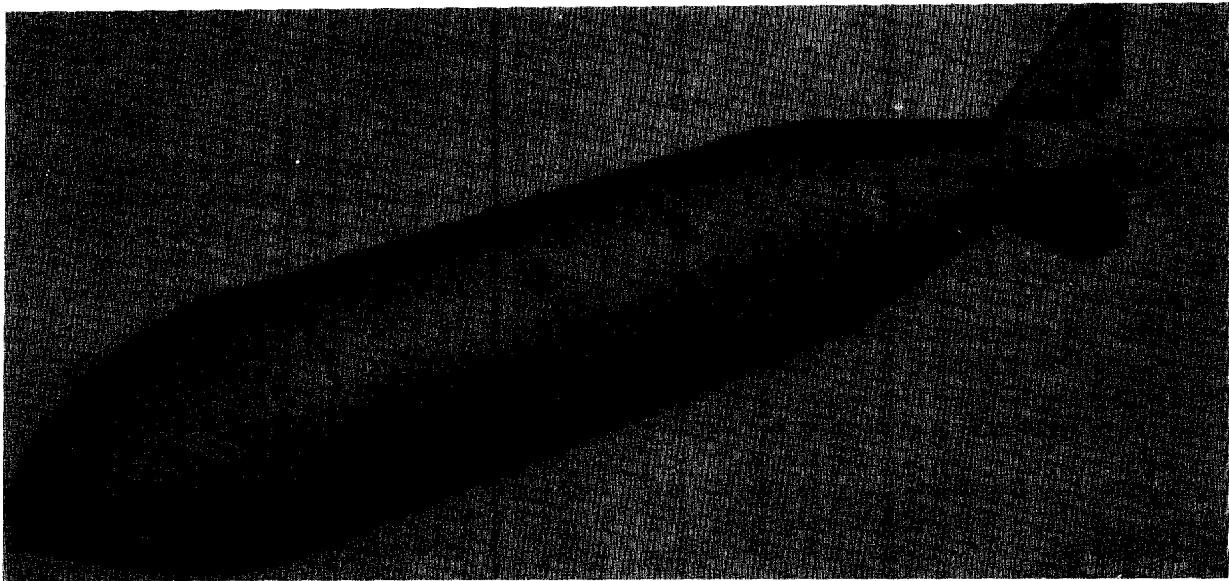

Fig 3-7 GAS BOMB CLUSTER, M34A1 (Converted to Streamlined Version for External Stowage on Aircraft)

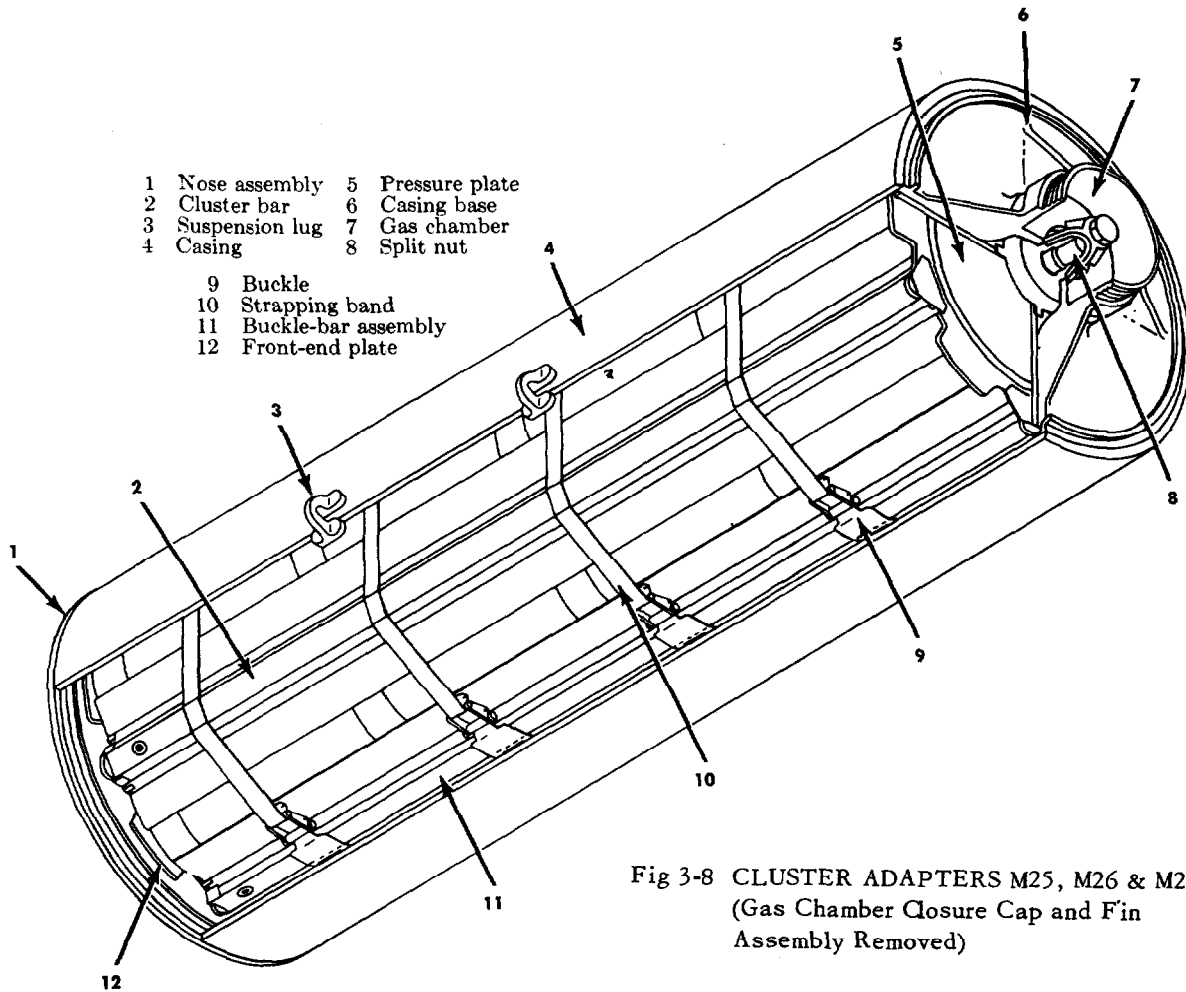

Fig 3-8 CLUSTER ADAPTERS M25, M26 & M29
(Gas Chamber Closure Cap and Fin
Assembly Removed)

175-lb BZ Incapacitating Gas Generator Cluster M44, consists of three 50-lb BZ Incapacitating Generators M16 clustered in generator cluster-adapter M39 forming one row. Generator M16 consists of 42 canisters M6 packaged in a pail and provided with a fuze and parachute. Canisters M6 are small cylindrical, sheet metal containers filled with a solid mixt of incapacitating BZ. A central cylindrical hole in the mixt is coated with a starter compn. A detailed description of this device including a Fig of its outside view is given in Ref 51a, pp 3-17 to 3-20

500-lb Cluster Adapter M25; 500-lb Cluster Adapter, M26 and 1000-lb Cluster Adapter, M29 are similar in construction and their cutaway view is in Fig 3-8. Each of them consists of a framework, a casing, a nose assembly,

three cartridge containers, a fin assembly and a burster. The burster consists of a detonating cord installed in a fin assembly between the two fuze adapter assemblies. The cord is wrapped once around a disc which is located inside the small end of the fin

When the cluster is released from an aircraft, the arming wire is withdrawn, the fuze arming vanes rotate in the airstream, and the fuzes arm. After the preset time has elapsed, one or both fuzes function and detonate the burster. Concussion from the explosion of the burster depresses the diaphragm in the striker assemblies driving the points of the strikers into the primers in the cluster-ejection cartridges, exploding the cartridges. Gases released by the cartridges pass thru the gas chamber, thru ventholes in the cham-

ber, and into the space between the adapter casing base and the pressure plate. Pressure developed by the gases forces the pressure plate toward the nose of the cluster and causes the stud attached to the pressure plate to pull out of the split nut which is screwed to the casing base. Continued expansion of the gases frees the nose assembly and forces the framework out of the casing. As each cluster buckle clears the casing, the buckle opens. After all buckles have opened, the adapter framework falls apart, allowing the bombs to fall individually to the target (Ref 51a, pp 3-22 & 3-23)

750-lb Cluster Adapter, M30, shown in Fig 3-9, is a component of incendiary bomb clusters M35 & M36 (shown in Fig 3-5).

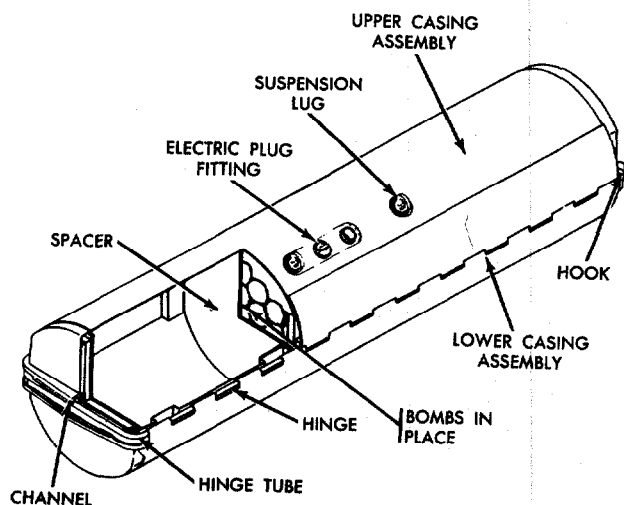

Fig 3-9 750-lb CLUSTER ADAPTER, M30

It consists of a casing fitted with a gasket, two suspension lugs, a hinge tube, an electric cable, two fuzes AN-M152A1 (described in Ref 51a, p 3-77), a burster (detonating cord), fin assembly M13 and arming wire assembly M23

When the cluster is released from the aircraft, the arming wire is withdrawn, the fuze arming vanes rotate in the airstream, and the fuzes are armed. After the preset time, one or both fuzes function, detonating the burster which breaks the hinges holding the cluster

together. The cluster opens, allowing the bomblets to fall individually to the target (Ref 51a, pp 3-27 & 3-28)

Section 6, Part C Bomb Fuzes Introduction

Bomb fuzes are devices used to initiate detonation of aerial bombs

They can be classified according to:

- 1) *Position* in which they are assembled to the bomb, as *nose, tail, or body*
- 2) *Arming Method*, as *pin-type arming or vane-type arming*
- 3) *Action or Function*, as *impact (I), nose or tail; time (T); mechanical time (MT), nose or tail; proximity or VT (variable time); all-delay, tail; multi-position (all-ways); hydrostatic; and electric*

Note: Definition of terms impact, time, proximity, etc fuzes are given in Section 5, Part A where is also explained the significance of letters AN, M, Mk, A, B, E, T, etc, which are followed by arabic numbers

Arming of fuzes may be subdivided into *direct arming* (when the fuze becomes armed immediately on ejection of the arming pin or by direct unscrewing of the arming stem by the vane) or *delayed arming* (when the ejection of the arming pin initiates a powder train or clockwork mechanism which arms the fuze after a predetermined time, or when the arming vane is connected to the arming stem by a reduction gear assembly)

A fuze in which the detonator is out of line with the booster "lead"; until armed, is classed as *detonator-safe*

In the pages which follow are described bomb fuzes which we consider to be typical

Section 6, Part C

a) Bomb Nose Fuzes

Nose Fuze AN-M103A1, shown in Fig 4-1, is cylindrical in shape, ca 2-inches in diameter and 7.23-in long (including the vane assembly). The fuze contains two explosive trains: one for delay action, and another for instantaneous action. The "delay action train" consists of a primer, a delay element,

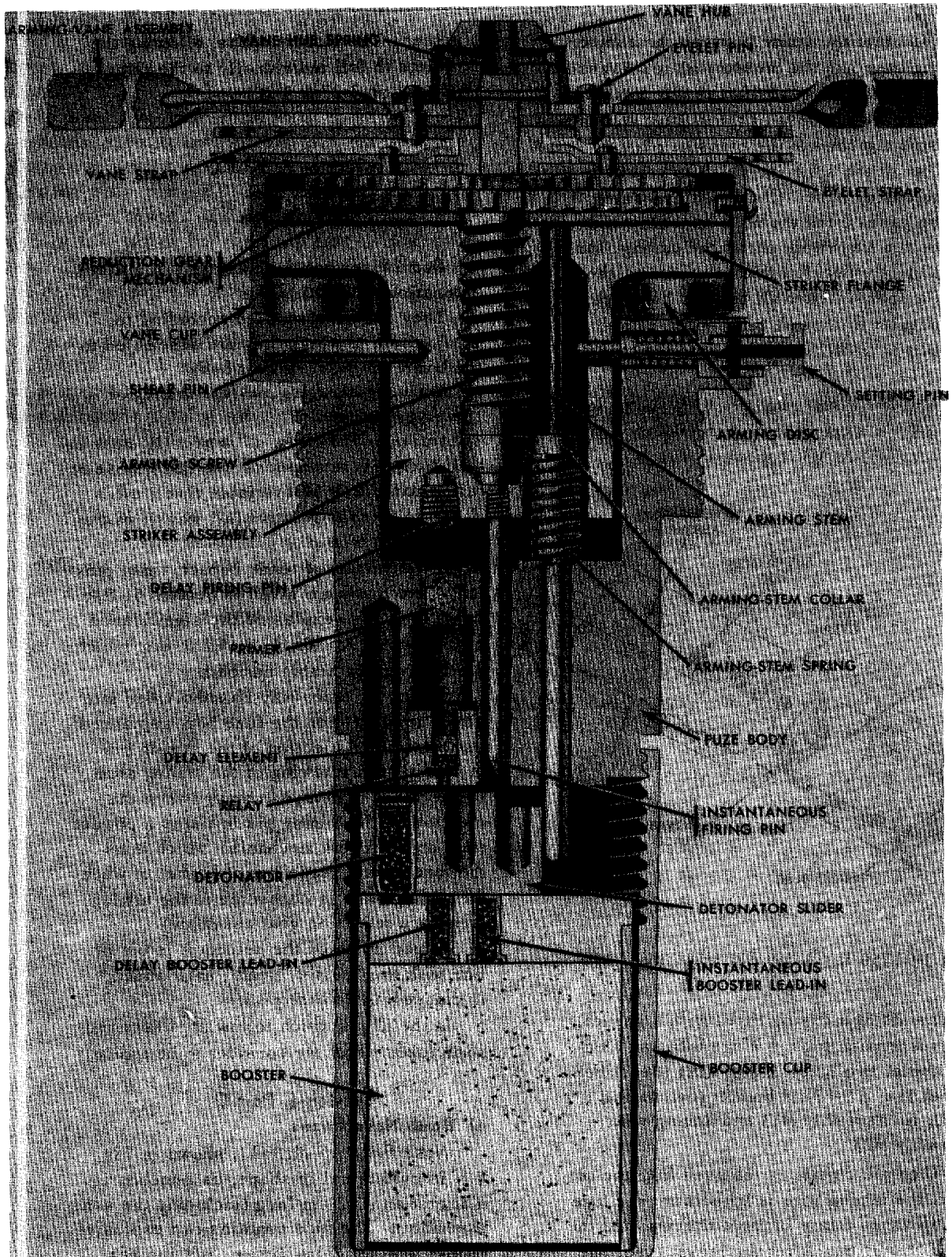

Fig 4-1 BOMB NOSE FUZE, AN-M103A1

a relay, a detonator, a booster lead-in, and booster (1.9-oz of Tetryl), all assembled in a fuze body and sealed to protect against moisture. The "instantaneous explosive train" consists of a detonator, a booster lead-in, and a Tetryl booster. The same detonator is used in both explosive trains. It is aligned with one of the expl trains during arming operation and its final position depends upon how the setting pin is inserted

When the fuzed bomb is dropped, the arming wire is retained in the bomb rack in order to free the arming vane assembly, thus causing it to rotate in the airstream. After traveling thru the air at a predetermined distance, the arming of delay mechanism is completed and further rotation unscrews the arming mechanism from the fuze

If the fuze has been set for "instantaneous action", the setting pin stem will not stop the progress of the arming stem during the flight, thus allowing it to ride outward. This clears both steps of the detonator slider and causes the detonator to align with the firing pin for the instantaneous expl train. Impact of the bomb drives the striker inward, thus shearing the shear pin & the stem of the setting pin and causing the instantaneous firing pin to hit the detonator. Its expln is relayed to the booster lead-in, booster and the main charge of the bomb

If the fuze has been set for "delay action" (usually 0.1 sec), the detonator is aligned with the delay expl components. Impact fires the delay primer. The flash from the primer sets off the BkPdr delay element which burns thru and sets off, respectively, the relay, the detonator, the booster lead-in, the booster and the main charge of the bomb. More detailed description of the AN-M103A1 fuze, especially of its arming mechanism is given in Ref 51a, pp 4-1 to 4-6

Nose Fuze AN-M103A1 is used in 1000-lb SAP Bomb; AN-M59A1, in AN-M59 Bomb and in some other bombs. A cutaway view of bomb AN-M59A1, showing location of both nose and tail fuzes is given here in Fig 2-1. One of the tail fuzes, AN-M102A2 used with

bomb AN-M59A1 is described in Ref 51a, pp 4-34 to 4-38. Nose fuze AN-M103A1 has also been used in some fragmentation bombs such as 90-lb Frag Bomb M82 (shown here in Fig 2-2) but only for nondelay action

Nose Fuze AN-Mk219, shown here in Fig 4-2 was developed by the Navy. Its overall length is 5.5-inches, diam of body in upper part ca 2.5-in and ca 1.75 in lower part. Total wt 4.0-lb. Its expl components consist of a detonator, an auxiliary-booster lead, a booster lead and a booster (ca 0.9-oz Tetryl). The booster screws into the fuze body and is held by the booster cover crimped into the provided groove. The fuze is set off when the firing pin is driven into the detonator upon impact. A safety (cotter) pin thru the vane-carrier lug and the flange of the striker, which locks the delay arming mechanism, provides safety for fuze during storage and shipping. The cotter pin is provided with a pull ring and an instruction tag. When the fuze is unarmed the expl train is broken. The delay arming mechanism provides maximum safety for dive bombing as well as protection against detonation when the bomb is accidentally released from an aircraft flying at low altitude

When the fuzed bomb is released free to arm, the vane carrier is unlocked from the striker flange by withdrawal of the arming wire. The vane carrier then rotates by action of the airstream on the arming-vane assembly, driving the reduction gears which arm the fuze. Completion of 175 revolutions of the arming-vane assembly (which requires ca 1000-ft of air travel along the trajectory) arm the fuze fully. Impact of the bomb drives the fuze head, vane-carrier, striker, and inner gear carrier into the fuze body, thereby shearing the pin in the shaft. The firing-pin extension on the inner-gear carrier strikes the firing pin and shears the firing pin. Then the firing pin penetrates and initiates the detonator which, in turn, fires an auxiliary booster lead, the booster lead, the booster, and finally the main charge of the bomb. Fuze detonation is instantaneous. There is no delay action provision. More detailed

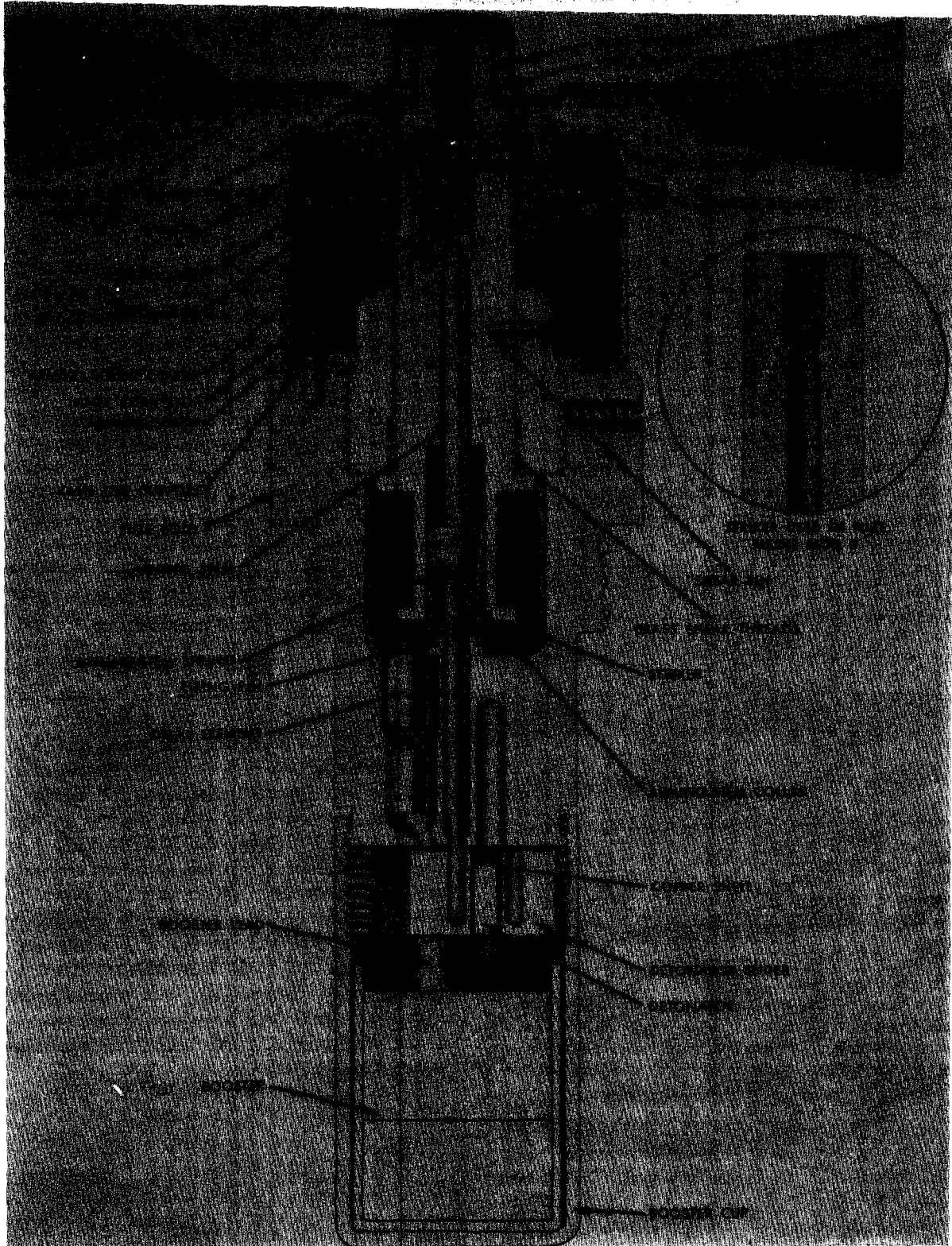

Fig 4-3 BOMB NOSE FUZE, Mk243Mod0

extra striker plate which increases the striking surface 7 times. Also the number of shear threads supporting the striker is only half the number of those on fuze Mk243Mod0. Fuze Mk244Mod1 will function even when dropped on soft ground (from an altitude of ca 1000-ft), or when dropped on water (from 3000-ft). The delay for functioning is 4-seconds

The expl components of each of the above fuzes consist of a delay element, a detonator, a booster lead, and a booster chge (1.9-oz of Tetryl). Its safety features consist of a safety (cotter) pin, which passes thru holes in the flange of the vane-cup and in the flange of the vane-cup support and locks the reduction mechanism to prevent the fuze from arming. The arming wire keeps the fuze unarmed until it is withdrawn when the bomb is released. These fuzes are "detonator-safe" and "shear-safe"

When the fuzed bomb is dropped, the arming wire is retained in the bomb rack and withdrawn from the vane-cup and vane-

cup support. This unlocks the reduction gear mechanism to arm the fuze. After 130 revolutions of the vane assembly (which corresponds to ca 450-ft of air travel of the bomb), the fuze becomes armed and the arming mechanism is released into the airstream. Impact with a sufficiently dense substance drives the striker inward which shears the brass shear threads & shear pin and then strikes the firing pin. The firing pin strikes the delay element, setting off the explosive train. The delay element relays the expln to the detonator which, in turn, sets off the booster lead, the booster, and the main charge of the bomb. More detailed descriptions of these fuzes, especially of their arming mechanisms, are given in Ref 51a, pp 4-17 to 4-20

Nose Fuzes M904E1 (and M904E2) are designed for use with fragmentation bombs, low-drag GP bombs, and massive-type gas bombs. These fuzes are superior to some older types because they provide for a wider range of selective arming, and impact firing

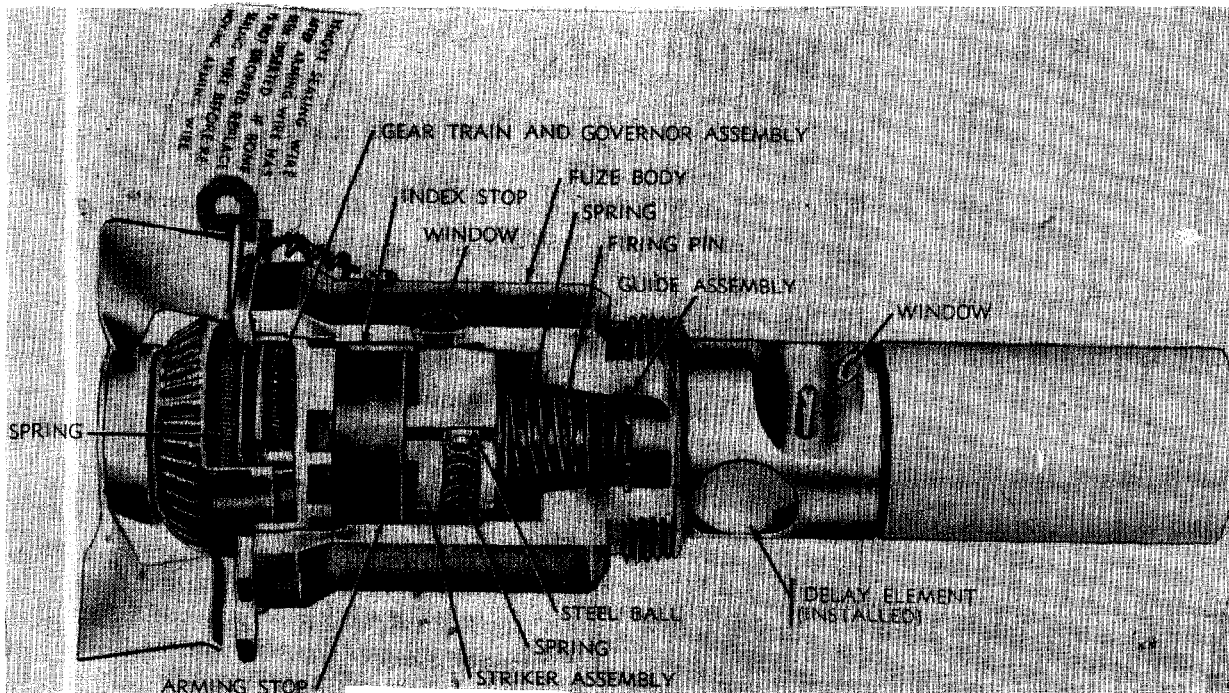

Fig 4-4 BOMB NOSE FUZE, M904E2

delays. A minimum airstream speed of ca 150 knots is required for arming. Both fuzes are structurally similar, but differ in their arming delay settings: 2 to 18-sec (selective) for E1 and 4 to 20-sec (selective) for E2. These fuzes can be used instead of fuzes AN-M103A1 (See Fig 4-1), AN-M139A1, AN-M140A1, M163, M164 & M165

Fuzes M904E1 or M904E2 are 9.38-in long, weighing 2.10-lb and protruding from the bomb 4.25-in. The construction of E2 is shown in Fig 4-4. The nose assembly contains housing & vane assembly, gear train & governor assembly, index ring, and arming stop. The vane assembly is secured to a spindle & drum assembly, thereby allowing two assemblies to turn as one unit. An indicator on the nose assembly is used in conjunction with a calibrated dial stamped on the flange for selecting arming delay time. The gear train and governor assembly, mechanically connected to the governor drum, are secured to the gear train which, in turn, is attached to the arming stop. The two drive pins of the arming stop are connected to the striker body assembly

The fuze body assembly consists of metallic body which contains index lock pin, stop screw, index stop, striker assembly, rotor release assembly, delay lock pin, and rotor assembly. The explosive train consists of delay element M9, relay XM9 (2.31 grains of LA), detonator M35 (in rotor assembly) and a booster cup assembly. The major components of this assembly are a booster lead of 1.55 grains Tetryl, a booster pellet of ca 1146 grains Tetryl, a filler disc, and an A1 booster cup. The threaded end of the cup is used for attaching the cup to the lower portion of the fuze body

When the delay indicator on the fuze body is rotated to some arming delay mark, the index lock pin must be pushed inward in order to release the index ring. If delay time of less than 6-sec is desired, the stop screw must be removed prior to selecting an arming time. The striker assembly, contg a steel ball, spring, and firing

pin guide, is held in place by the index stop which is secured to the fuze body. The firing pin assembly is fastened to the guide assembly with a shear pin. The guide assembly is held in place in the fuze body with a retaining ring. Relay element XM9 is located in the lower portion of the fuze body. Delay element M9, when installed in the cutout in the fuze body, is held in place by a spring and a lock pin. The lower portion of the locker release assembly holds the rotor assembly (with detonator M35) in an out-of-line position with other expl train elements. The window in the middle of the fuze body is used to view the white stripes on the striker body; full red color indicates that the fuze is armed. The window in the lower portion of the fuze body is used for viewing the upper edge of the rotor assembly; full red indicates that the rotor has been released and detonator M35 is in line with the other expl train elements

The composition of explosive train used in this fuze is indicated above

When the fuze is released from the aircraft the arming wire is withdrawn from the vane and the safety pin (called "Fahnestock", which is Ger for "flagstaff") clips. As soon as the speed reaches 150 knots, the vane starts to spin by airstream, producing sufficient torque for arming the fuze. Rotation of the vane provides the drive power for the governor spindle and drum assembly, while the centrifugal-type clutch maintains the output speed from the governor at a speed 1800 ± 100 rpm. The governor output is transmitted thru the gear train and this causes the arming stop to rotate thru an angle corresponding to the selected arming time. While the arming stop is rotating to the armed position, three other parts are rotating with it: the striker body, the firing pin and the firing pin guide, driven by the drive pins and keyed to the arming stop. When the arming stop has moved to the armed position, a slot in the striker body aligns with a slot in the index stop. The helical spring forces the striker body forward until it rests against the index stop

of the arming stop. Immediately, a helical spring forces the steel ball into the void above the firing pin. A cut-out in the firing pin guide aligns with the upper portion of the rotor release assembly allowing it to be driven forward by the spring. On removal of the lower portion of the release assembly, the spring-loaded rotor starts to revolve, thereby aligning the detonator M35 in the rotor assembly with the other expl train elements. The rotor detent locks the rotor assembly in the firing train position, thus arming the fuze. When the bomb hits the target, the force of the impact drives the entire nose assembly rearward, thereby causing the three integral lugs attached to the nose housing to be sheared off. The striker body is forced against the firing pin, shearing the shear pin, which, in turn, causes the expl train components to be initiated so that the main charge of a bomb such as shown in Fig 2-4 can be detonated.

A simpler, in construction than previously described fuzes, is the *Impact Nose Fuze M142A1*, designed to be installed in the 10-lb Incendiary Bomb M74 (or M74A1), during their manuf and not to be removed in the field. It is described in Ref 51a, pp 4-24 & 4-25, but not described here because it was replaced in most cases by M197 described below.

An improved version of the M142A1 fuze is the *Impact Nose Fuze M197*, (shown here in Fig 4-5) is used in 10-lb Incendiary Bomb M74A1 (shown here in Fig 2-6). The fuze is the direct-arming, arming-pin type, which functions at any angle of impact. It is installed in the bomb nose during manuf and its removal or replacement in the field is not authorized. The diameter is 1.19-inches and the length 3.19-in. A case (3) incloses a striker (4), a sleeve (5) containing a primer (6), and a delay mixture (7). A head assembly (2) containing an arming pin (14) and a slide bar (13) is screwed into the open end of the case. A booster cup containing a booster (8) is assembled to the end of the case that contains the delay mixture. A safety wire (1), which is removed when the bomb is clustered, holds the arming pin in the fuze

When a bomb contg this fuze is clustered, the safety wire is withdrawn. The arming pin is held in the fuze by contact with the release bar which is held in place by contact with other bombs in the cluster. The stem of the arming pin holds the slide bar in the retracted position, and the slide-bar spring (12) is compressed. The striker and sleeve are locked together by two steel balls (11) located in two holes in the striker.

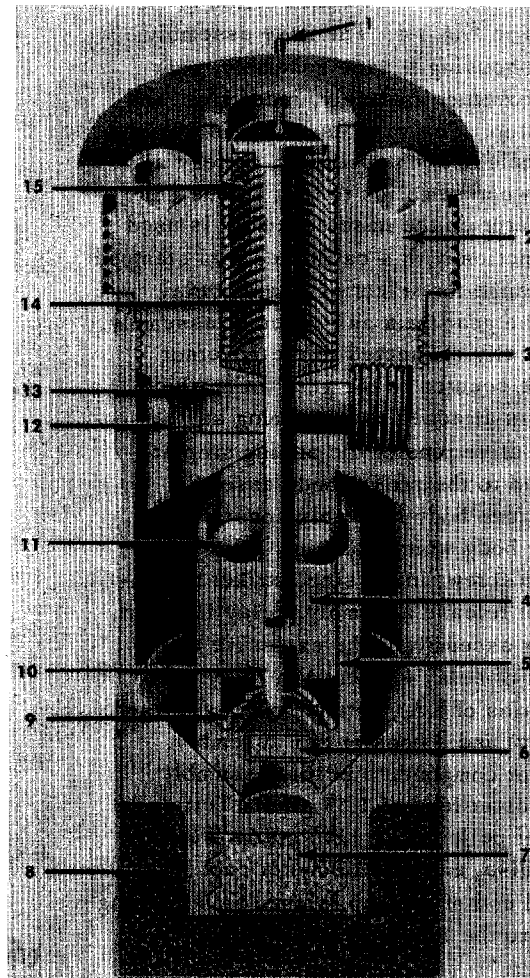

- | | |
|-----------------|----------------------|
| 1 Safety wire | 9 Striker spring |
| 2 Head assembly | 10 Firing pin |
| 3 Case | 11 Steel ball |
| 4 Striker | 12 Slide-bar spring |
| 5 Sleeve | 13 Slide bar |
| 6 Primer | 14 Arming pin |
| 7 Delay mixture | 15 Arming-pin spring |
| 8 Booster | |

Fig 4-5 BOMB NOSE FUZE, M197

Each ball is held outward in a recess in the sleeve by the stem of the arming pin. This prevents the firing pin (10), which is part of the striker, from striking the primer

Release of the bomb from the cluster moves pressure from the arming pin, which is ejected from the fuze by the arming-pin spring (15). Withdrawal of the stem of the arming pin frees the two steel balls to move toward the center of the fuze, unlocking the striker from the sleeve. The striker and sleeve are then free to move in either direction. The firing pin is held away from the primer only by the striker spring (9), and the fuze is armed. Withdrawal of the arming pin also frees the slide bar, which is forced by the slide-bar spring toward the center of the fuze. The slide bar then covers the hole in the center of the fuze and prevents fire from the igniting components of the fuze from venting forward

Upon impact. If the bomb strikes nose end first, inertia causes the sleeve to move toward the striker, compressing the striker spring. The primer hits the firing pin and is activated. Flame from the primer ignites the delay mixture, which burns from 1.5 to 3-seconds, and then ignites the booster, completing the fuze action. If the bomb strikes tail end first, inertia causes the striker to move toward the sleeve, compressing the striker spring and allowing the firing pin to strike the primer. The delay mixture and booster are then ignited as described above. If the bomb strikes with the side of the fuze turned toward the point of impact, inertia causes both the striker and the sleeve to move toward the side of the fuze, and the striker is forced into the sleeve by the sloping surfaces of the fuze head and case. The firing pin strikes the primer, which ignites the delay mixture and booster, as described above (Ref 51a, pp 4-31 to 4-33)

Fuze M197 (as well as Fuze M142A1) is screwed in the nose of 10-lb Inc Bomb M74A1 (shown in Section 6, Part A, Fig 2-10), with the booster end of fuze inside the dome and adjacent to the bags of the Inc mixture Mg/BkPdr, located in the nose's dome of the bomb

Nose Fuze AN-M159 (See Fig 4-6) is used in larger than 10-lb incendiary bomb such as in 100-lb Inc Bomb, AN-M47A4, shown in Fig 2-11 in Section 6, Part A

The fuze AN-M159 is 1.75-inches in diameter and 3.25-inches long. A brass body (9) contains an arming mechanism (2), a firing pin (14), a rotor (11) and a detonator (12). An arming vane is attached to the arming hub (3) at the nose end of the fuze. Two arming-wire guides (1) are part of the arming vane and turn with it. Two more arming-wire guides are fastened to the fuze body. A sealing wire prevents the arming vane from being rotated accidentally

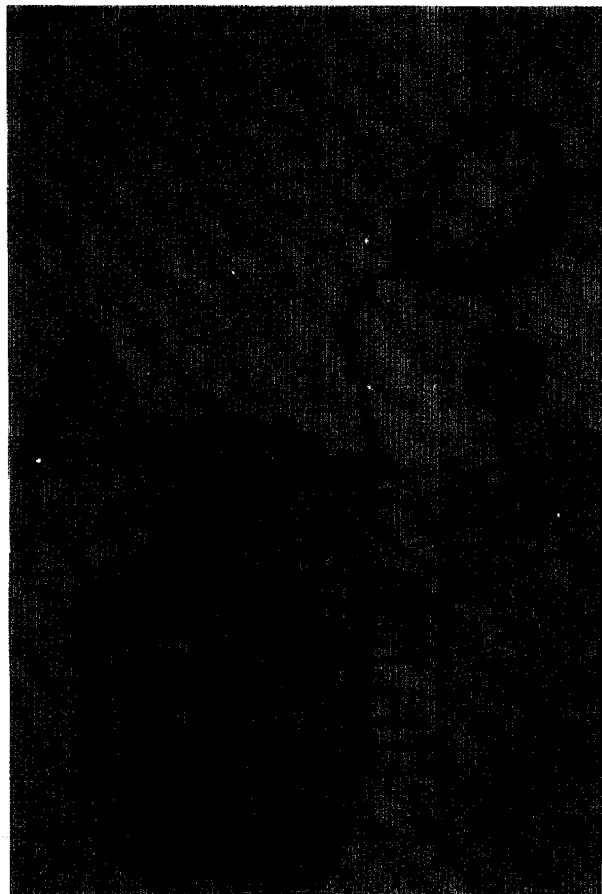

- | | |
|----------------------|----------------------|
| 1 Arming-wire guides | 9 Body |
| 2 Arming mechanism | 10 Rotor spring |
| 3 Arming hub | 11 Rotor |
| 4 Arming sleeve | 12 Detonator |
| 5 Gear | 13 Detonator M20 |
| 6 Pinion | 14 Firing pin |
| 7 Gear | 15 Firing-pin spring |
| 8 Pivot | |

Fig 4-6 BOMB NOSE FUZE, AN-M159

Arming mechanism. The arming mechanism (2) consists of an arming hub (3), a pinion (6), an arming sleeve (4), a 39-tooth gear (5), and a 40-tooth gear (7). The arming hub and arming vane rotate freely on ball bearings in the nose of the fuze. The 39-tooth gear on the inner end of the arming hub meshes with the pinion. The arming sleeve with a firing pin assembly mounted in it is screwed part way into the interior of the arming hub. The 40-tooth gear on the inner end of the arming sleeve meshes with the pinion, which is grooved to accommodate the 40-tooth gear.

Firing pin assembly. The firing pin assembly, mounted inside the arming sleeve, consists of the firing pin (14) and the firing-pin spring (15). The point of the firing pin extends into a chamber inside the fuze body. The firing pin is held in the arming sleeve by a shoulder near the center and is forced toward the fuze nose by the spring.

Rotor. The rotor (11), on a pivot (8) in the chamber inside the fuze body, holds detonator M20 (13) set in a hole drilled thru the rotor. A second hole drilled partly thru the rotor receives the firing pin when the fuze is unarmed. A rotor spring (10) attached to the rotor bears against the fuze body and tends to pivot the rotor into the armed position. A spring-loaded detent in the nose end of the rotor latches the rotor in place when it moves to the armed position.

Detonator. The detonator is an explosive charge in a metal holder screwed into the bottom of the fuze.

Before release. Before the fuzed bomb is released, the arming wire prevents the arming vane from turning. The end of the firing pin in the hole in the rotor holds the rotor in the unarmed position with the primer out of alignment with the arming pin and detonator.

After release. When the bomb containing the fuze is released, the arming wire is withdrawn. This frees the arming vane to rotate in the airstream, thereby turning the arming hub. The 39-tooth gear attached to the arming hub turns arming vane, the

rotor spring forces the rotor to pivot until the primer is in line with the firing pin and the detonator, and the fuze is armed. As the firing pin assembly moves forward, the head of the firing pin progresses out of the fuze body. When the fuze arms, the head is approximately one-quarter of an inch forward of its original position. After arming is completed, the arming sleeve continues to move forward until the 40-tooth gear enters the groove in the pinion and disengages from the teeth, at which time the arming sleeve ceases to advance.

Upon impact. When the head of the firing pin hits a solid object, the point is forced into detonator M20 which functions and explodes the lower detonator, completing the fuze action (Ref 51a, pp 4-10 & 4-11).

Its installation in 100-lb AN-M47A4 Inc Bomb is shown in Fig 2-11 in Section 6, Part A.

Nose Fuze M157 (Fig 4-7) is interesting because it can be used with Bomb Igniter M15 or M16 (Fig 4-8) to allow a jettisonable fuel tank to be used as a *fire bomb*. The M157 is an impact fuze of the direct-arming vane type which functions at any angle of impact. Its cylindrical body, 1.13-inches in diameter and 3.38-in long consists of a case (5) inclosing a striker (6), and a sleeve (7) which contains a primer (9), and a 3/4-grain BkPdr ignition mixt (10). A head assembly (3), contg an arming vane (1) and a threaded arming pin (4) is screwed into the open end of the case (5). A safety (cotter) pin (2) with a pull ring is inserted thru a pair of holes in the arming vane to prevent it from turning. A short wire with a safety clip attached is inserted thru a 2nd pair of holes in the arming vane. The arming pin (4), [which is attached to the vane (1)], extends into the center of the fuze thru the striker (6) and sleeve (7), both of which are locked together by two steel balls (12) located in two holes of the striker (6). Each ball is held outward in a recess of the sleeve (7) by the stem of the arming pin (4). This prevents the firing pin (8) which is part of the striker, from hitting the primer

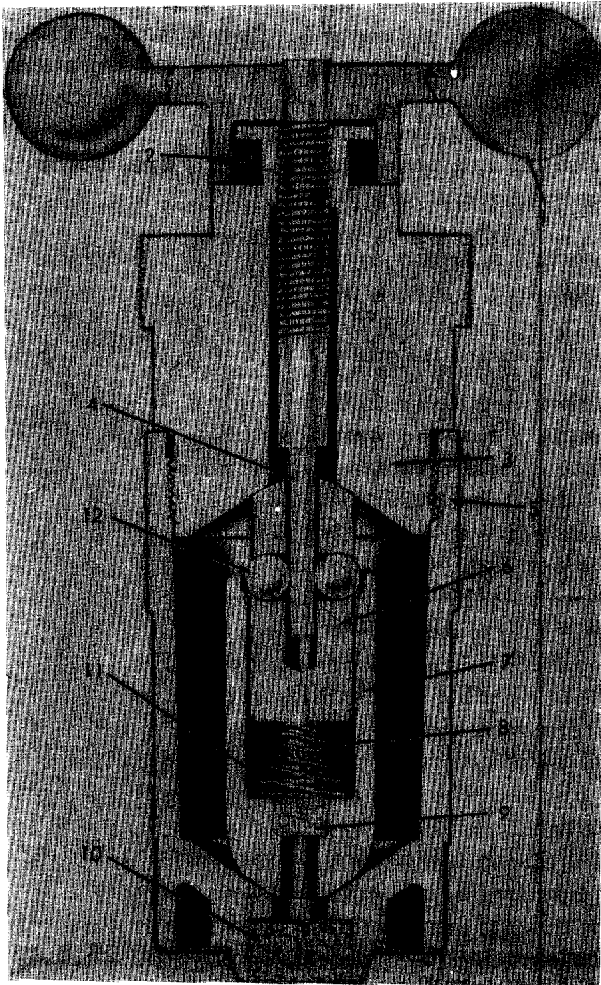

- | | |
|-----------------|---------------------|
| 1 Arming vane | 7 Sleeve |
| 2 Safety pin | 8 Firing pin |
| 3 Head assembly | 9 Primer |
| 4 Arming pin | 10 Ignition mixture |
| 5 Case | 11 Striker spring |
| 6 Striker | 12 Steel ball |

Fig 4-7 BOMB NOSE FUZE, M157

(9). When the fuel tank is jettisoned, the arming wire is withdrawn, freeing the arming vane to rotate in the airstream. After approximately 20 revolutions of the arming vane, the end of the arming pin withdraws from the striker and frees the two steel balls to move toward the center of the fuze, unlocking the striker from the sleeve. The striker and sleeve are then free to move in either direction. The firing pin is held away from the primer only by the striker spring (11), and the fuze is armed

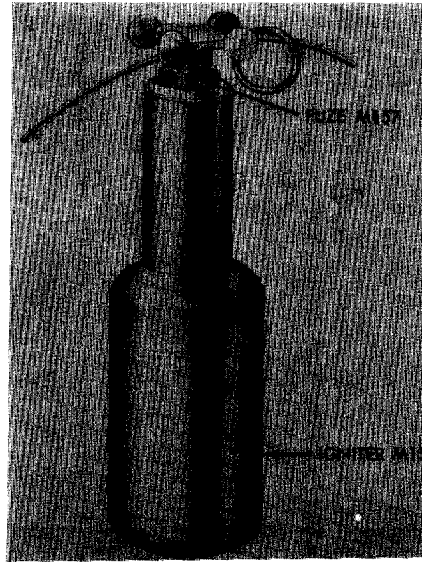
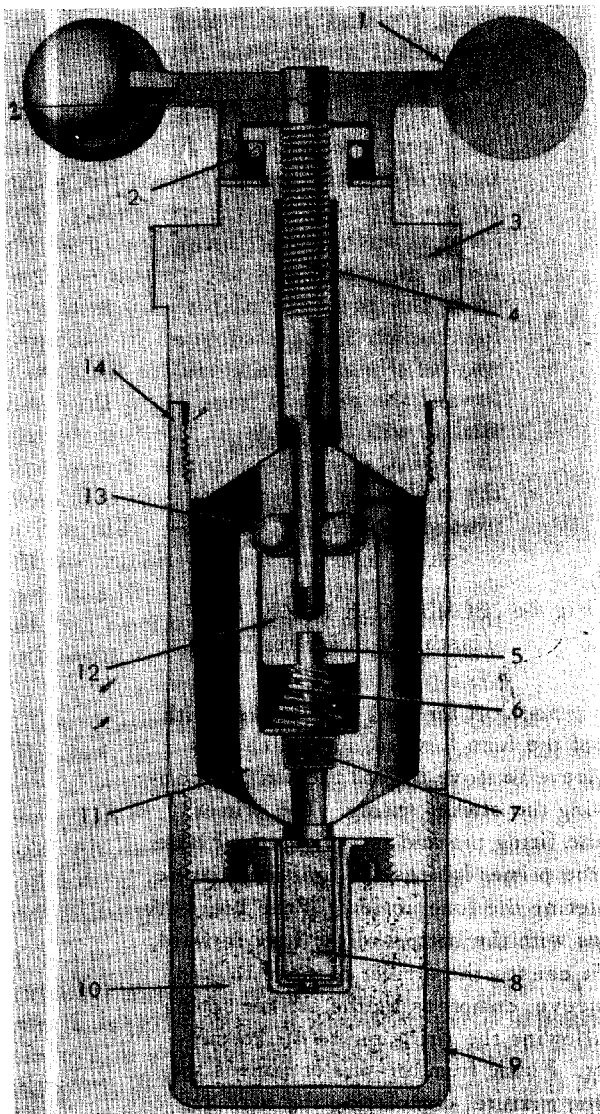

Fig 4-8 BOMB NOSE FUZE, M157
(Installed in Igniter M15)

Upon impact. If the fuel tank strikes with head of the fuze forward, inertia causes the sleeve to move toward the striker, compressing the striker spring. The primer hits the firing pin and is activated. Flame from the primer ignites the ignition mixture, completing the fuze action. If the fuel tank strikes with the bottom of the fuze forward, inertia causes the striker to move toward the sleeve, compressing the striker spring and allowing the firing pin to strike the primer. Flame from the primer ignites the ignition mixture, completing the fuze action. If the fuel tank strikes with the side of the fuze forward, inertia causes the striker and the sleeve to move toward the side of the fuze, and the striker is forced into the sleeve by the sloping surfaces of the fuze head and case. The firing pin strikes the primer, and the ignition mixture is ignited as described above (Ref 51a, pp 4-26 to 4-28)

Fuze M157 can also be used in 750-lb and 500-lb fire bombs, which are described below (See Figs 2-12, 2-13 and 2-14)

Nose Fuze AN-M173A1, shown in Fig 4-9, is cylindrical in shape, 2-inches in diam and 4.19-in long. A case (14)



- | | |
|------------------|------------------|
| 1 Arming vane | 8 Detonator |
| 2 Safety pin | 9 Booster cup |
| 3 Head assembly | 10 Booster |
| 4 Arming pin | 11 Primer holder |
| 5 Firing pin | 12 Striker |
| 6 Striker spring | 13 Steel balls |
| 7 Primer | 14 Case |

Fig 4-9 BOMB NOSE FUZE, AN-M173A1

incloses a striker (12) and a primer holder (11) with a primer (7). A booster cup, containing a detonator (8) and a booster (10) is assembled at the lower end of the case. A head assembly (3) is screwed to the top of the case. An arming pin (4) with an arming vane (1) at its outer end is screwed into

the head assembly (3). A safety pin (2) with a pull ring is inserted thru a hole in the hub of the arming vane. A 2nd hole in the hub of the vane receives an arming wire which prevents the vane from turning before the bomb is released. The striker and primer holder are locked together by two steel balls (13) located in holes of the striker (12). Each ball is held outward in the recess of the primer holder (11) by the stem of the arming pin (4). This prevents the firing pin (5) from striking the primer (7). When the fuze bomb falls from the aircraft, the arming wire is withdrawn, thus freeing the arming vane (1) to rotate in the airstream. After 15-20 revolutions of the vane, the arming pin (4) unscrews ca 3/16th of an inch and frees the balls (13) to move toward the center of the fuze. This unlocks the striker (12) from the primer holder (11), thus freeing them to move in any direction. The fuze is now armed and the firing pin (5) is held away from the primer (7) only by the striker spring (6)

If the bomb strikes with the vane end toward the target, inertia causes the primer holder (11) to move toward the striker (12) compressing its spring (6) and forcing the primer (7) to hit the firing pin (5). Flame from the primer initiates the detonator (8) which causes detonation of Tetryl booster (10) and bomb filler

If the bomb strikes with the booster end toward the target, inertia causes the striker (12) to move toward the primer holder (11), thus compressing the striker spring (6) and causing the firing pin (5) to strike the primer (7), etc

If the bomb strikes with the side of the fuze toward the target, inertia causes both the striker (12) and the primer holder (11) to move toward the side of the fuze. The striker is forced into the primer holder by the sloping surfaces of the fuze head and case; the firing pin strikes the primer and the fuze action is completed as described above (Ref 51a, pp 4-28 to 4-30)

Section 6, Part C

b) Bomb Tail Fuzes

Tail Fuzes AN-M100A2 and the other thirteen fuzes listed in Ref 51a, p 4-35 are vane-armed and inertia-fired. Arming is mechanically delayed by reduction gearing. When issued the fuzes are equipped with either a nondelay or a 0.025-sec delay primer-detonator M14, which can be interchanged with other primers-detonators M14 to give a selection of time delays. Air travel to arm these fuzes ranges from 445 to 650-feet with vane M4 and 1225 to 1240 with vane M5. Overall length of the fuzes varies because of the differences in the length of the arming-stem tube. Tail fuzes AN-M100A2, AN-M101A2 & AN-M102A2 are for use with box fin assemblies. Fuzes M172, M175, M176, AN-M177, M184 & M185 are used with conical fin assemblies. Fuzes M185, M194 & M195 are used only in low-drag bombs. The slight differences between these fuzes are discussed in Ref 51a, pp 4-35 & 4-36

Bomb Tail Fuze AN-M100A2, shown in Fig 4-10, may be considered as a typical representative of fourteen tail fuzes cited above. The fuze is 1.5-inches in diam, 9.26-in long, and weighs 2.7-lb. It is made safe for shipment and storage by insertion of a safety (cotter) pin that extends thru the fuze body and firing plunger, which fires the detonator. Thru a set of holes in the bearing-cup eyelet and arming-stem cup, a safety (cotter) pin locks the gear mechanism. A sealed safety wire is threaded thru a hole in the lower end of the cotter pin to prevent its removal. The fuze cannot be installed without first removing the cotter pin from the fuze body. When installed in a bomb with the arming wire in place, the arming vane is prevented from rotating and arming the fuze. Although the firing plunger is always in line with the explosive train, it is held in place by the arming stem until it is unscrewed by rotation of the arming vane assembly

When the fuzed bomb is dropped, the arming wire is retained in the bomb rack and withdrawn from the fuze. This frees

the arming-vane assembly which rotates in the airstream and arms the fuze. After the arming vanes have made from 150 to 170 revolutions, the fuze is fully armed. After appr 200 more revolutions, the arming stem unscrews from the fuze body cap and the entire assembly (arming vanes, reduction gears, and arming stem) is released into the airstream. Air travel necessary to arm these fuzes varies with the bomb and arming vane used. Upon impact, inertia drives the firing plunger into the primer to fire the fuze and detonate the bomb

The arming-vane assembly is attached to the bearing cup by the vane nut, and is locked in place by eyelet pins. The eyelet pins fit into notches in the vane hub to insure positive rotation of the bearing cup with the arming-vane assembly. Delay arming is obtained by reduction gearing between the arming-vane assembly and the arming stem. The ratio is 30 revolutions of the arming-vane assembly to one revolution of the arming stem. Reduction is derived from a pinion (idler) gear, a movable gear, and a stationary gear. The movable gear has 30 teeth; the stationary gear has 29 teeth. The pinion gear is driven around the stationary and movable gears by the bearing cup and arming-vane assembly. Since the movable gear contains one more tooth than the stationary gear, it is forced one tooth ahead with each complete revolution of the pinion around the stationary gear. When the pinion has circled the stationary gear 30 times, the movable gear has completed one revolution. The gear is connected to the arming stem by means of a movable-gear carrier. The stationary gear is secured to the stationary-gear carrier. Rotation of the movable gear is prevented by the carrier stop. As the arming-vane assembly rotates, motion is transmitted thru the reduction gears to the arming stem and as the stem rotates, it unscrews from the firing plunger and fuze body cap. The arming-vane assembly is strong enough to withstand air speeds up to 600 knots

When the arming stem has unscrewed itself from the firing plunger, arming is

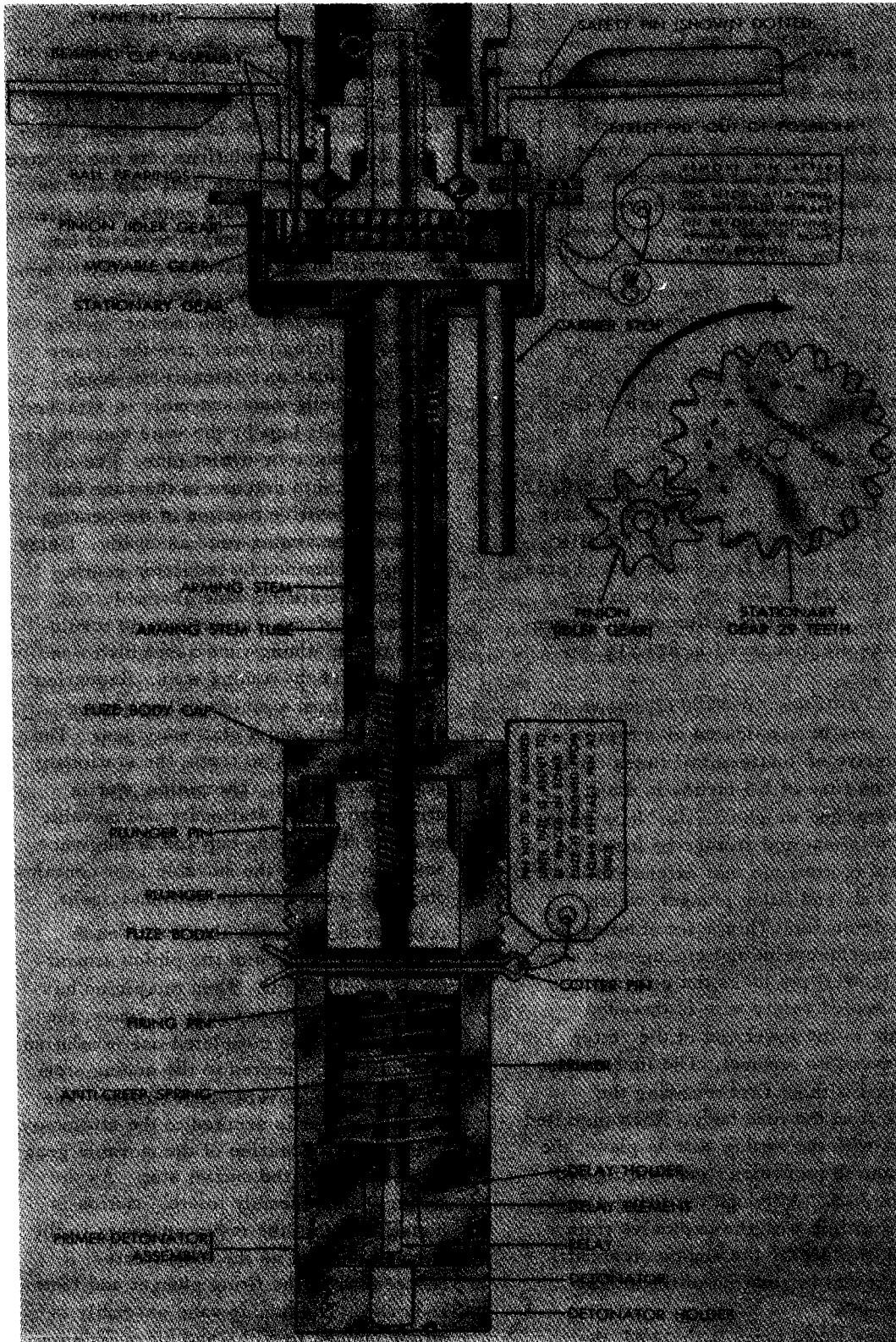

Fig 4-10 BOMB TAIL FUZE, AN-M100A2

complete. The firing mechanism consists of a firing plunger and an anticreep spring. A guide pin thru the fuze-body cap and into the firing plunger prevents rotation of the plunger as the arming stem unscrews, but does not prevent the plunger from sliding in and out. The anticreep spring supports the plunger against the fuze-body cap. This spring is only strong enough to support the wt of the firing plunger. Upon impact, the plunger compresses the anticreep spring and is driven forward into the primer by inertia

When the primer is struck by the firing pin, it flashes and sets off the delay element. After burning thru, the delay element sets off the relay which fires the detonator and the bomb (Ref 51a, pp 4-36 to 4-38)

Tail Fuze M115, shown in Fig 4-11, as well as fuzes *M116 & M117* are vane-operated and inertia-fired. Their arming is mechanically delayed by reduction gearing. The expl components of the fuzes are located in one interchangeable primer-detonator. By substituting different delay elements, the delay time between impact and detonation of bomb can be varied (from 4-5 to 8-15 sec delay). The fuzes in this series have the same body diameter (1.5-inches), but differ in overall lengths (9.54-in for M115, 12.54 for M116 and 16.54 for M117) so that they can be used in various size bombs. The differences in length are necessary to locate the arming vane assemblies properly in the airstream. Standard arming-vane M4 (45° pitch) is used for shorter arming distances (445 to 650-ft), while vane M5 (75° pitch) is for longer arming distances (1225 to 1420-ft). Their weights are 2.7, 2.9 & 3.2-lb, respectively

Their safety features are discussed in detail in Ref 51a, p 4-42

When the fuzed bomb is dropped, the arming wire is withdrawn from the fuze and retained in the bomb rack. This frees the arming-vane assembly, allowing it to rotate in the airstream and arm the fuze. After the required number of revolutions, the fuze is fully armed. After approximately 200 more revolutions of the arming-vane assembly,

the arming stem unscrews from the fuze body cap and the entire arming assembly (arming-vane assembly, reduction gears, and arming mechanism) is released into the airstream. As the bomb size increases, greater air travel is required for arming, ranging from 80 to 1420-feet depending on which fuze, bomb, and arming vane are being used. Upon impact, inertia drives the firing pin into the primer to fire the fuze and detonate the bomb

A more detailed description of arming is given in Ref 51a, pp 4-42 & 4-43

Tail Fuzes M112A1, M113A1 and M114A1 differ from the M115 series in that they do not have reduction gears in the vane assembly and, therefore, can arm move quickly. They are designed for use with box fins and differ from each other only in length. Each type has the same diam (1.43-inches), but their wts are different (2.3, 2.5 & 2.8-lb, respectively)

When released from a plane and the vanes complete 18 to 21 revolutions, the arming stem, secured to the vane nut by a safety (cotter) pin, becomes unthreaded from the plunger. After 100-ft of air travel the fuzes are armed and will function on impact. They are not to be used from aircraft carriers (Ref 51a, p 4-41)

Tail Fuzes M178, M179 and M180 have the same operating characteristics as the M112A1 series (no reduction gear, fast arming) but incorporate the longer arming stem necessary for use with a conical fin assembly. Their bodies are of the same diam (1.5-in), but the lengths and wts are different (24.85, 36.65 & 44.71-inches, respectively, and 3.4, 4.1 & 4.6-lb, respectively). Their firing delay is from 4-5 sec to 8-15 sec (Ref 51a, pp 4-41 & 4-42)

Tail Fuzes M181, M182 and M183 have the same operating characteristics as the M115 series (reduction gear in the arming vane assembly) and they also incorporate the longer arming stem necessary for use with a conical fin assembly. Their body diam is 1.5-inches; overall lengths 24.6, 36.97 & 45.03-inches, respectively; and

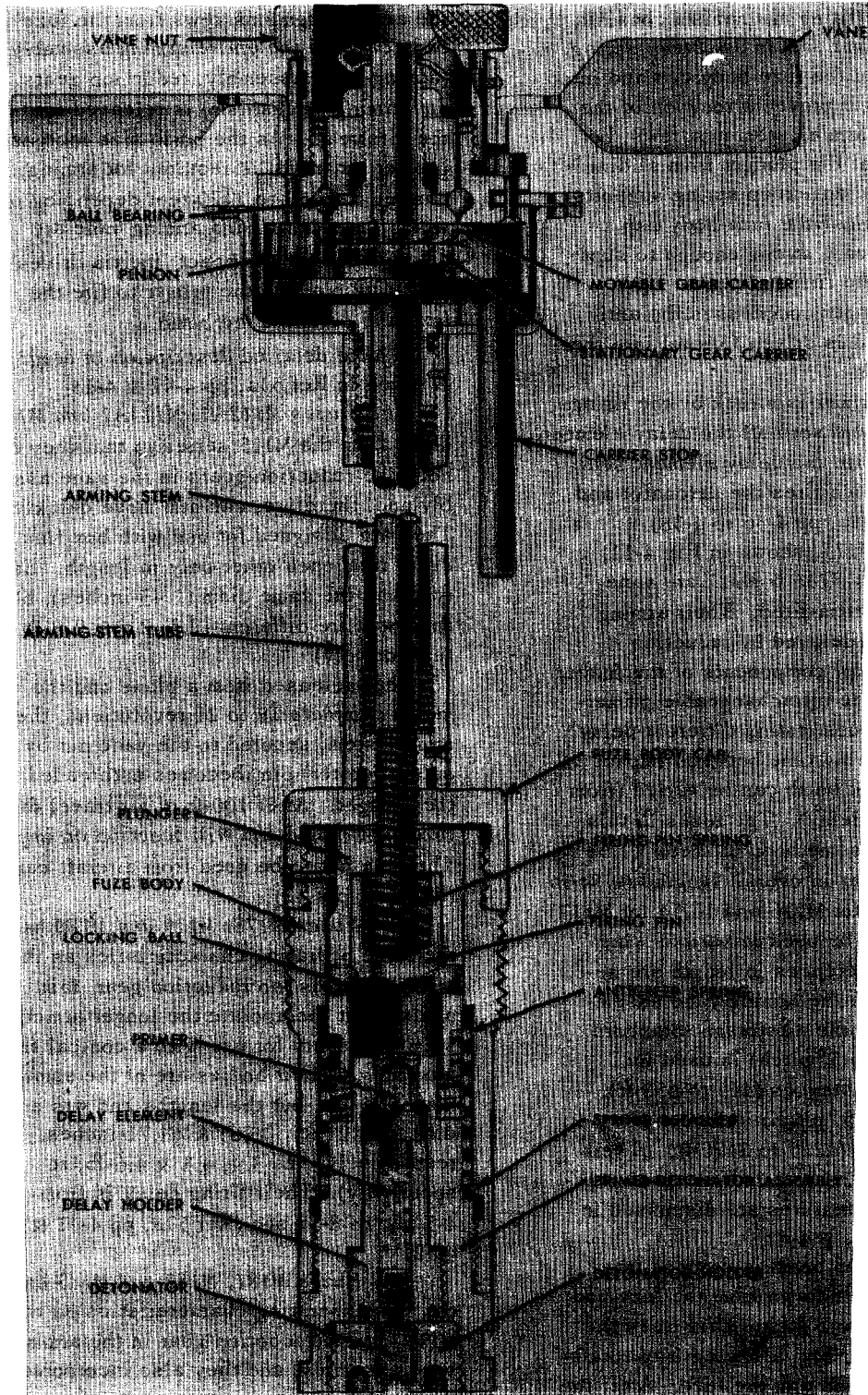

Fig 4-11 BOMB TAIL FUZE, M115

weights 3.65, 4.4 & 5.0-lb, respectively (Ref 51a, pp 4-41 & 4-42)

Tail Fuze AN-Mk228, shown in Fig 4-12, is bottle-shaped with a 16-blade arming-vane assembly attached to its outer end. A cylindrical extension housing the booster (with 38.2 grains of Tetryl), projects from the base of the fuze body. Its overall length is 16.4-in, wt 10.5-lb, and diam of its widest part is ca 3-in. It is detonator-safe, delay-armed type arming after 1100-ft of air travel and functions upon impact thru two independent trains of 0.08-sec delay. The fuze is used in armor-piercing bombs to allow penetration of the target before detonation

When the fuzed bomb is dropped, the arming wire is withdrawn from the arming-vane assembly, thus allowing it to rotate. This rotation is transferred to the arming shaft thru a reduction-gear train which arms the fuze. After 150-160 revolutions of the arming-vane assembly, all the elements of the expl train are locked in alignment, and the fuze is armed. Upon impact, inertia forces the striker and inner gear carrier toward the booster, shearing the shear-pin which runs thru the supporting collar and arming shaft. The firing-pin extensions, protruding from the inner-gear carrier, strike the firing pins driving them into their primers. One firing-pin extension is slightly longer than the other to allow the expl components not to be initiated simultaneously. Greater reliability of fire results from this arrangement since all the force of the inner-gear carrier and striker is directed onto one firing pin at a time. The firing pins cause the primers to ignite and the resulting flash sets off the delay elements, which are followed by relay elements, detonators, auxiliary booster leads, booster leads, booster and main charge of the bomb (Ref 51a, pp 4-44 to 4-47)

Tail Fuze AN-Mk247Mod0, described in Ref 51a, pp 4-48 to 4-50 and shown in Figs 4-34 and 4-35 (not reproduced here) contains no internal expl components since it serves only as a trigger for firing the signal in a practice bomb

Tail Fuzes M123A1, M124A1 and M125A1 are of the same design, except that their overall lengths are different (9.24, 12.24 and 16.24-inches, respectively) and so are their wts (2.9, 3.1 and 3.4-lb). Their bodies are cylindrical having diam ca 1.5-in. Their firing action is chemical (long-delay, 1 to 144 hrs, or instantaneous on attempted withdrawal). Typical of these fuzes, M123A1, is shown here in Fig 4-13. The only expl element in these fuzes is the detonator located in the detonator holder which screws into the base of the body extension only at the time of fuzing the bomb. The detonator is then in line with the spring-loaded firing pin and remains so during all operations. When the fuzed bomb is dropped, the arming wire is withdrawn from the arming-vane assembly, stem disc, and clip. The freed vane-assembly starts to rotate in airstream and this movement is communicated to the arming stem which is connected to the vane assembly by means of a safety catch. As the rotation proceeds, the arming stem becomes screwed into the ampoule retainer and into the ampoule retainer nut. After a short air travel (80 to 100 ft), the stem moving into the fuze body crushes the ampoule (its material is not given) and frees its contents (a solvent for celluloid, probably acetone). With additional air travel (900 to 1800 ft), the stem moves far enough to force the stem collar against the retainer-locking nut. This action seals the outer end of the fuze body to prevent the escape of solvent and the entrance of moisture. The solvent from the crushed ampoule filters thru the delay wad to contact the celluloid delay collar, thus softening it after certain delay. The function of this collar is to prevent the firing balls holding the firing pin screw (See Figs 4-13 & 4-14B) from being forced outward while the celluloid collar is not softened yet by the solvent. As soon as the collar softens (or dissolves), the balls move outward, thus releasing the head of firing pin screw and firing pin spring (Fig 4-14B). As result of this, the firing pin punctures the sealing disc and strikes the detonator, thus exploding its charge.

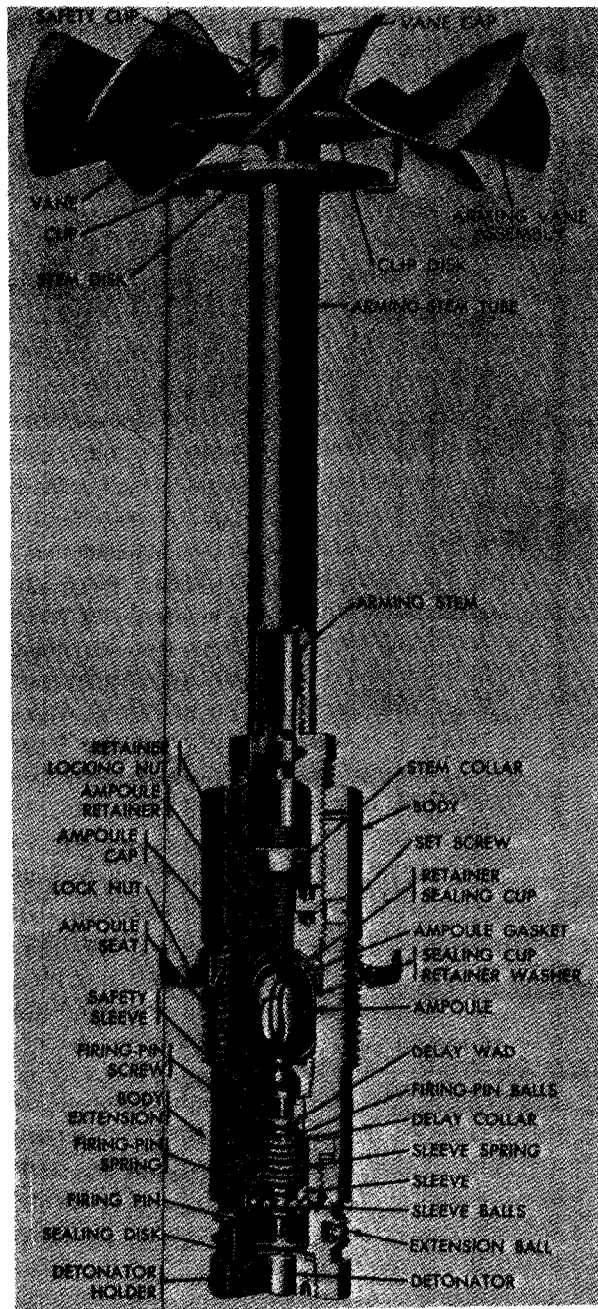

Fig 4-13 BOMB TAIL FUZE, M123A1

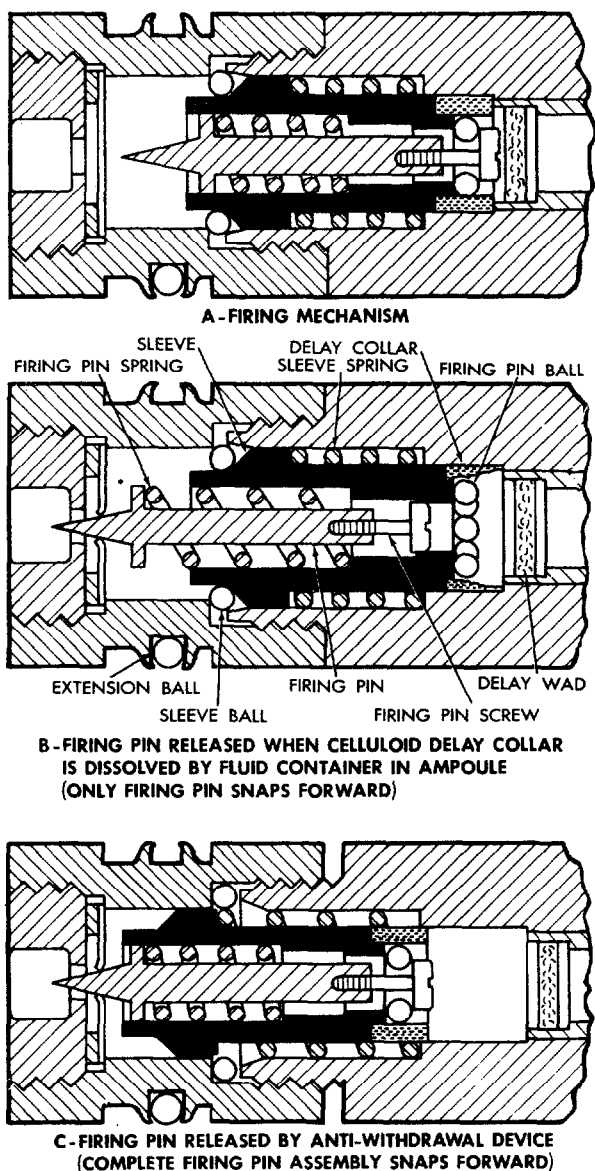

Fig 4-14 BOMB TAIL FUZE, M123A1
(Operation)

Each of these fuzes is equipped with an antiwithdrawal device and any attempt to remove the fuze after it is installed in the bomb would result in an expln. The result of action of antiwithdrawal device is shown in Fig 4-14C

Delay times of these fuzes are considerably affected by temperature changes - increase in temp above "nominal" temp,

such as 50° F, accelerates the action of fuze, while at temps below 50° F the action is retarded (Ref 51a, pp 4-52 to 4-55 and Ref 19b, pp 163 to 172)

Accdg to Ref 19b, Fuze M123A1 was authorized for use in GP and demolition bombs of 100 to 300-lb (p 164); Fuze M124A1 in demolition, GP and SAP bombs of 500 to 600-lb; and Fuze M125A1 in demolition, GP, and SAP bombs of 1000-lb and over, except the LC(light case) bombs

Tail Fuzes M132, M133 and M134 are of the same construction (See Fig 4-15), differing only in overall lengths (9.57, 12.5 & 16.57-inches, respectively) and weights (2.1, 2.3 & 2.6-lb). Diameter of their cylindrical bodies is ca 1.5-in. They are vane-operated, delay-armed and incorporate an antiwithdrawal feature. All fuzes act to detonate the bomb 16-mins after arming at a temp of 80° F. The delay time will vary with changes of temp. There are four vanes which can be operated either at 45° pitch (for shorter arming distances) or at 75° pitch (for longer distances). The detonator is the only expl component in these fuzes. It is located in the detonator holder and the ensemble is not connected with the fuze until its insertion into the bomb prior to flight. The firing mechanism consists of a firing pin, an arming housing, a compressed firing-pin spring and firing-pin balls. The balls seat in the groove of the firing pin and as long as they remain there, the compressed firing-pin spring is prevented from driving the firing pin into the detonator. The lower lip of the arming housing retains the balls in this position preventing them from riding up on the fuze body shoulder and releasing the firing pin. The celluloid cylinder of the delay element is positioned between the delay holder and the arming housing. This prevents the compressed firing pin spring from raising the arming housing and freeing the firing-pin balls. When the fuze is installed in the bomb, the arming wire prevents the arming stem from rotating and arming the fuze. This is the only safety feature afforded these fuzes after they are installed. Attempted with-

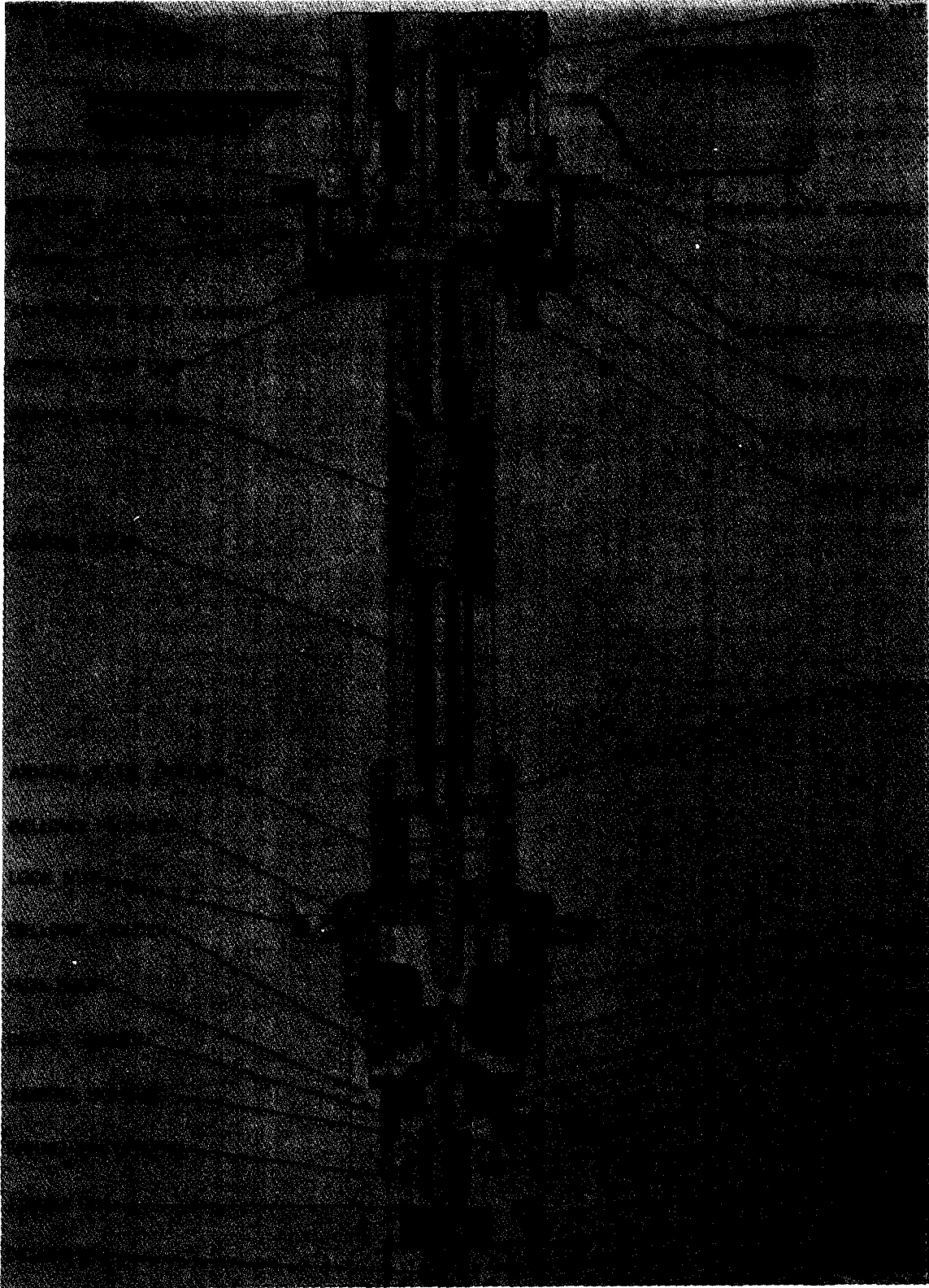

Fig 4-15 BOMB TAIL FUZE, M132

drawal or tampering will cause the fuze to detonate the bomb. An antiwithdrawal device used in these fuzes is briefly described in Ref 51a, p 4-51

When the fuze bomb is dropped, the arming wire of the fuze becomes withdrawn (because it remains retained in the bomb rack), and this frees the arming-vane assembly to rotate in the airstream. The revolving motion of the assembly is transmitted thru the reduction gears to the arming stem, which is threaded at its lower part into the bellows-plunger. The arming-stem collar is pinned to the arming stem to prevent any axial movement of the stem. As the arming-stem revolves, it is unscrewed from the bellows-plunger and this forces the plunger inward compressing the bellows and puncturing the sealing cup. The solvent for celluloid (compn not given) contained in the compressed bellows is forced out thru the bellows holder and from now on the fuze becomes armed

The solvent from bellows filters thru the openings in the delay holder and is then absorbed by the felt washers, which act as wicks, feeding the solvent gradually toward the celluloid cylinder. After a time lapse which depends upon the ambient temperature, the cylinder is softened sufficiently to allow the firing-pin spring to move upward, thus forcing the arming housing upward. As result of this the firing-pin balls will move outward, thus releasing the firing-pin spring so that it can drive the firing pin against the detonator. Expln of detonator charge sets off the booster chge and then the main chge of the bomb (Ref 51a, pp 4-56 to 4-62 and Ref 19b, pp 173-80)

Accdg to Ref 19b, Fuze M132 was authorized for use with 100 & 300-lb demolition and GP bombs; Fuze M133 with 500 & 600-lb bombs; and Fuze M134 with 1000-lb and over bombs

Tail Fuze M190 is an inertial type consisting of a fuze-body assembly, arming assembly, flexible shaft, and arming-vane assembly. Its cylindrical body of 1.5-inches diam and 6.89-in length is threaded externally for assembly to the fuze adapter of

GP bomb M117. The end of the fuze body which enters the adapter is threaded internally to receive primer-detonator M14. An arming stem tube extends from the opposite end of the fuze body and is assembled to form a part of the fuze body assembly. The M190 is similar to fuzes M905 and M906 in that it utilizes a flexible drive shaft which connects the arming mechanism to the arming stem. The arming mechanism is mounted on the side of the fin cone on tail fin M131 of GP bomb M117. An anemometer-cup arming vane is attached to the arming mechanism by a bayonet-type fastener. The fuze body, flexible shaft, arming mechanism, and arming vane are shipped as a complete assembly and as such is inert. The fuze is made safe by means of a cotter pin that extends thru the fuze body. Primer-detonator M14 with the required delay is inserted when preparing the fuze for use, but prior to this the arming wire is inserted and the cotter pin is removed. When the fuze bomb is dropped, the arming wire is withdrawn (being retained in the bomb rack) and this frees the arming vanes to rotate in the airstream, thus turning the flexible shaft and the arming stem connected to it. After traveling thru the air a prescribed distance, the fuze becomes armed. It can be detonated either instantaneously or after delays of 0.01 to 0.24-sec. The fuze is described in Ref 51a, pp 4-63 & 4-64 without giving its cutaway view. Its outside view shown in Fig 4-43 of Ref 51a is not reproduced here

Tail Fuzes M905 and M906 have similar components to Nose Fuze M904-series, shown here in Fig 4-4, although their operations differ. Their bodies are cylindrical, diameter ca 2 inches and overall length 6.38-in for M905 and 6.5-in for M906

Tail Fuze M905 is used in conjunction with Nose Fuze M904-series and when assembled in the new-series of Low-Drag GP Bomb (such as shown here in Figs 2-6 and 2-7, it requires the use of adapter-booster T46E4. The arming of fuze M905 is accomplished by arming-drive assembly M44 (T25) thru the rotation action of flexible

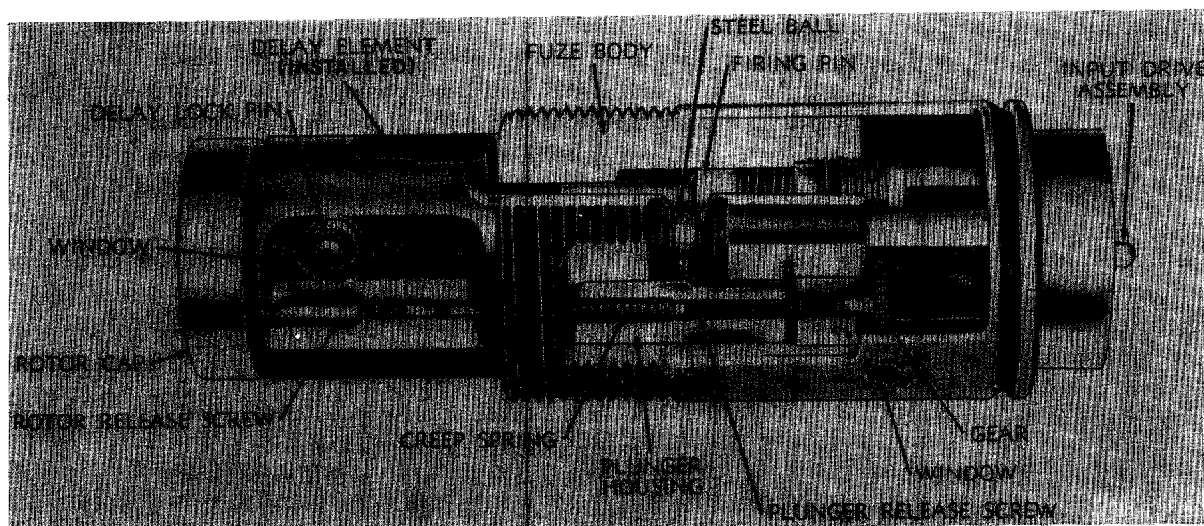

Fig 4-16 BOMB TAIL FUZE, M906

shaft M40 (T40) instead of the arming vane. The fuze has a selective arming time-delay of 4 to 20-sec and its firing pin is actuated by inertia instead of by impact as does M904. Fuze M905 is described in Ref 51a, pp 4-65 to 4-66, where Fig 4-44 gives a general view, while Fig 4-45 gives its cross-section

Tail Fuze M906, shown here on Fig 4-16, is used for low-level tactical bombing when a longer firing-time delay is needed to assure that the released aircraft will be safe from the explosive envelope of the bomb prior to its initiation. It has been used with the 750-lb GP Bomb M117 (See Fig 2-5) and Low-Drag GP Bombs (See Figs 2-6 & 2-7). Arming-drive assembly M44 (T25) is used with adapter-booster A6E4. The fuze has no selective-arming time-delay provisions and the arming time delay of ca 2-sec is predetermined by design requirements

The major components of the fuze are the input-drive housing assembly, the fuze body assembly and the rotor assembly. The input-drive assembly is used for transmitting circular motion to the fuze for release and freeing of the plunger-release screw which is mechanically connected to the rotor-release screw. The teeth of the gear on the upper portion of the input

assembly shaft mesh with the teeth of the gear of the plunger-release screw. The fuze body assembly contains a spring-loaded firing pin and a plunger-release screw. The oval opening in the side of the fuze is used for the insertion of delay element T5E3

Fuze functioning is initiated when the arming wire is pulled out of the vane tab and Fahnestock (safety) clips in the arming-drive assembly. The 1800 revolutions-per-minute output of the arming-drive assembly is transmitted thru a flexible shaft coupling to the input-drive assembly and reduction-gear train which drives the plunger-release screw. Rotation of the plunger-release screw causes it to be withdrawn from the plunger assembly. After withdrawal, the plunger is free to move longitudinally upon sufficient deceleration of the fuze. The creep spring prevents the plunger from moving when velocity changes occur during free fall of the bomb. As the plunger-release screw rotates, the rotor-release screw assembly, which is mechanically keyed to it, withdraws from the rotor-assembly cavity, allowing the rotor to move by spring action and bring detonator M35 in line with the rest of the explosive train elements. The rotor detent locks the rotor in the armed position. The fuze is completely armed within approximately 2 seconds

When the bomb hits the target, inertial force generated by the bomb deceleration causes the plunger assembly to move forward. When an annular groove in the plunger aligns with the steel ball that detents the firing pin, the ball is forced into the plunger groove; the firing pin, thus freed, is propelled into the primer of the delay element by the firing-pin spring, thus initiating the explosive train elements. The explosive train is identical to that in fuze M905, except delay element T5E3 or T6E4 is used in place of delay element M9

Section 6, Part C

c) Bomb MT (Mechanical Time) Fuzes

Nose and tail MT fuzes, although varying in explosive characteristics, are essentially of one type. They resemble MT artillery fuzes described in Section 5, Part C. The principle of operation is that of the common alarm clock. A trigger arm assembly (firing lever and timing disc lever) which restrains a spring-loaded firing pin, rides on the edge of a circular timing disc. An arming pin, located in a notch in the edge of the timing disc, locks it in the unarmed position. When the arming pin is ejected, the clockwork mechanism turns the disc at a uniform rate until the timing disc lever drops into the notch and releases the firing pin. Rotating the head of the fuze to locate the timing disc lever at a given distance from the arming pin, gives the time-setting desired. This description applies to the older types of MT fuzes such as *Nose Fuzes AN-M145A1, AN-M146A1 and AN-M147A1* (described in Ref 51a, p 4-71 to 4-77) or to *Tail Fuzes M152A1 and M155A1* (described in Ref 51a, pp 4-77 to 4-79)

Cutaway views of AN-M146A1 fuze are given in Figs 4-17a & 4-17b, and cutaway view of M155A1 is given in Fig 4-18

In the newer types of MT bomb fuzes, such as M907, M908 and M909 (described in Ref 51a, pp 4-80 to 4-84), the arming mechanism consists of an arming assembly to which the arming vane is attached by a bayonet-type locking arrangement, a gover-

nor drum & a governor plate assembly, and a set of reduction gears and shafts which terminate in a large arming gear. A cutout on the arming gear allows the arming stem to move forward when the gear has rotated into the armed position and a spring-loaded slider, containing a primer, is released to the armed position. The timing mechanism consists of a spring-driven clock movement which terminates in a timing disc. A cutout in the timing disc triggers the firing mechanism

All currently used types of MT fuze, except M155A1 are detonator-safe (i.e., the detonator is held out of line with the booster-lead until the fuze arms)

Cutaway view of MT fuze M907 is given in Fig 4-19

Nose and Tail MT Fuzes (older as well as newer designs), consist of a body which contains the time element & the expl train, and a head which contains the mechanical arming & firing system. Head and body are held together by a spring steel ring which is positioned by three screws in the fuze body. Variation of the pressure of the ring provides a means of adjusting the torque required to set the fuze. A thumbscrew is provided to lock the head in position when the setting is made. The arming pin and arming-wire guide are assembled on the side of the body opposite the thumbscrew. An index mark for time setting is engraved in the body just below the head. The time graduations are engraved around the base of the head, and two stop pins are set in the time scale so as to butt against the arming-wire guide at maximum and minimum time settings. The arming hub with the vane assembly, the arming sleeve, and the firing pin with striker head, project thru the forward end. A "C"-shaped safety block is held between the striker and the vane nut by the arming sleeve. In current models, the safety block has a collar which bears on pins in the vane nut. This assures that the block will spin with the arming vane and develop sufficient centrifugal force to throw the block clear when the arming sleeve is withdrawn. As the fuze is issued, there

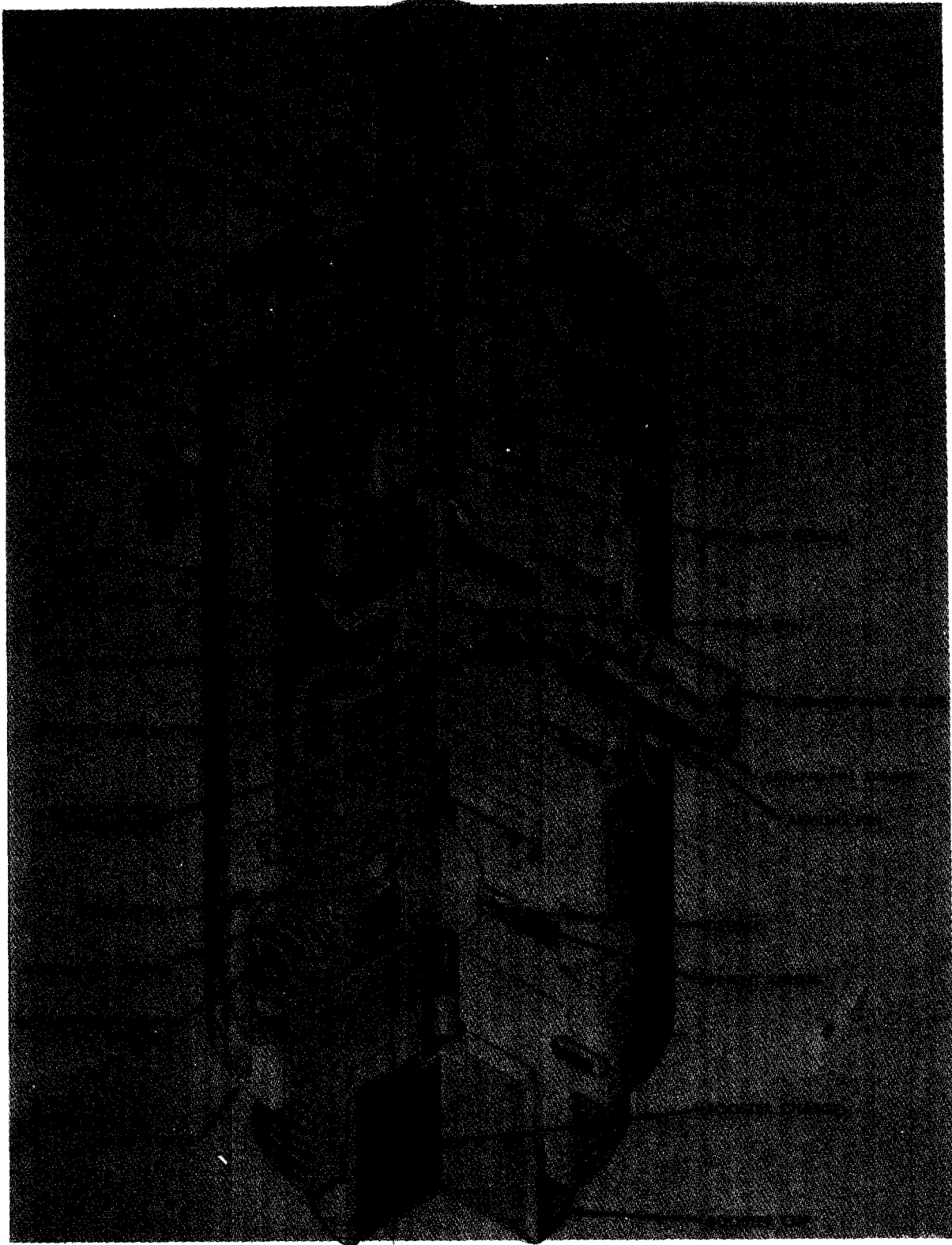

Fig 4-17a BOMB NOSE MT FUZE, AN-M146A1
(Unarmed)

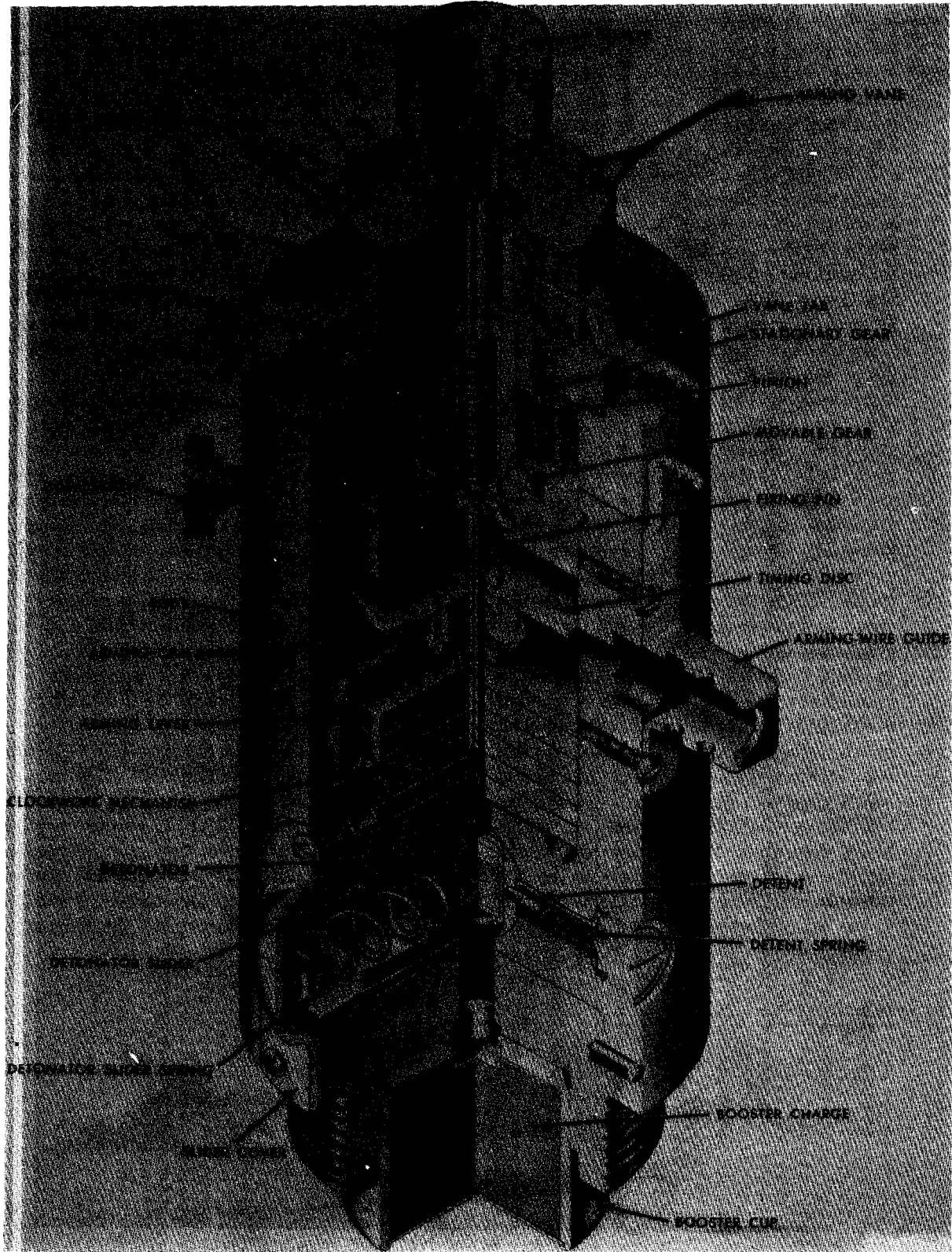

Fig 4-17b BOMB NOSE MT FUZE, AN-M146A1
(Armed)

is a forked striker stop in place between the striker and the safety block and a cotter pin thru the inner of a pair of eyelets in the arming-wire guide and vane tab

The new MT fuze M907 does not utilize an arming sleeve or a safety block as stated above for other models (Ref 51a, p 4-70)

MT Nose Fuze AN-M146A1, shown in Figs 4-17a and 4-17b is cylindrical in shape, diam of body 1.93-in, overall length 6.3-in and total wt 1.6-lb. It is equipped with M19A2 detonator and its booster contains 110 grains of BkPdr. When the fuze is released the arming wire withdraws from the fuze and remains in the bomb rack. As the wire is withdrawn, the arming pin is ejected by the arming-pin spring and the arming-vane assembly rotates in the airstream. When the arming pin is ejected, the time mechanism is set in motion, initiating the time train and turning the time-arming cam. After 4.5-sec, the time-arming cam allows the detonator to align with the expl train (Fig 4-17b). The arming-vane assembly operates the delay-arming mechanism to remove the safety block between the striker and the vane-nut. Air travel of 1000 to 1300-ft is required for the arming vane assembly to remove the safety block. If not previously fired by the timing mechanism for the time set (5 to 92-sec), the fuze will then function on impact (Ref 51a, p 4-74)

MT Nose Fuzes AN-M145A1 and AN-M147A1, briefly described in Ref 51a, p 4-71 without giving their cutaway views, are similar to AN-M146A1, except that their booster charges are of Tetryl (7.6 grains) and that they contain in addition lead charges (5.6 grains of Tetryl). The function of lead charge is not explained

MT Tail Fuze M152A1, briefly described in Ref 51a, p 4-77 without giving its cutaway or outside view, is designed for use in clusters only. Except for some details, the fuze is similar to AN-M145A1 listed above and in Ref 51a, p 4-71

MT Nose (or Tail) Fuze M155A1, shown in Fig 4-18, is cylindrical in shape having

a body diam 1.63-inches, overall length 4.5-in and weighing 1.4-lb. It is equipped with M26 percussion primer and booster contg 120 grains of BkPdr. Being not "detonator-safe" and capable of functioning even when dropped unarmed, the fuze is not allowed to be installed in bombs or clusters before they are placed on the aircraft. Its use on carrier-based aircraft is forbidden. The fuze arms after traveling thru the air ca 50-ft and it detonates either in the air after delay preset between 5 and 92-sec, or instantaneously on impact. Its operation is similar to that of AN-M146A described above (Ref 51a, pp 4-78 & 4-79)

MT Nose (or Tail) Fuze M907, shown in Fig 4-19, is designed for airburst functioning (4 to 92-sec firing delay) of photoflash bombs (such as shown in Fig 2-23) and bomb cluster. It is cylindrical in shape with diam of body 2.75-inches, overall length 5.54-in and weighs 2.20-lb. Its stab primer, M72, contains 5.72 grains of explosive and its booster contains 100 grains of BkPdr Grade A-4. For nose application arming vane T5E2 is used, while for tail application vanes T3 or T4 are used. Fuze M907 has improved safety characteristics, environmental resistance, versatility, and functional reliability, which makes it suitable to replace MT fuzes AN-M145A1 or AN-M146A1. Arming of this fuze requires a minimum of 1500 rpm of the arming vane and release speed of aircraft should be between 160 & 600 knots

The fuze starts to operate when the bomb is released from the aircraft and the arming wire is withdrawn from the arming vane and the arming pin bracket. The arming pin is ejected from the fuze body, thereby allowing the timing disc of the movement assembly to rotate. The firing pin then retracts to the firing position. Rotation of the vane drives the centrifugal governor which limits input speed to the gear train to ca 1500 rpm. This makes the vane drum lose contact with the governor weights. Arming time is determined by the angle thru which the arming gear must rotate in order for the slot in the arming

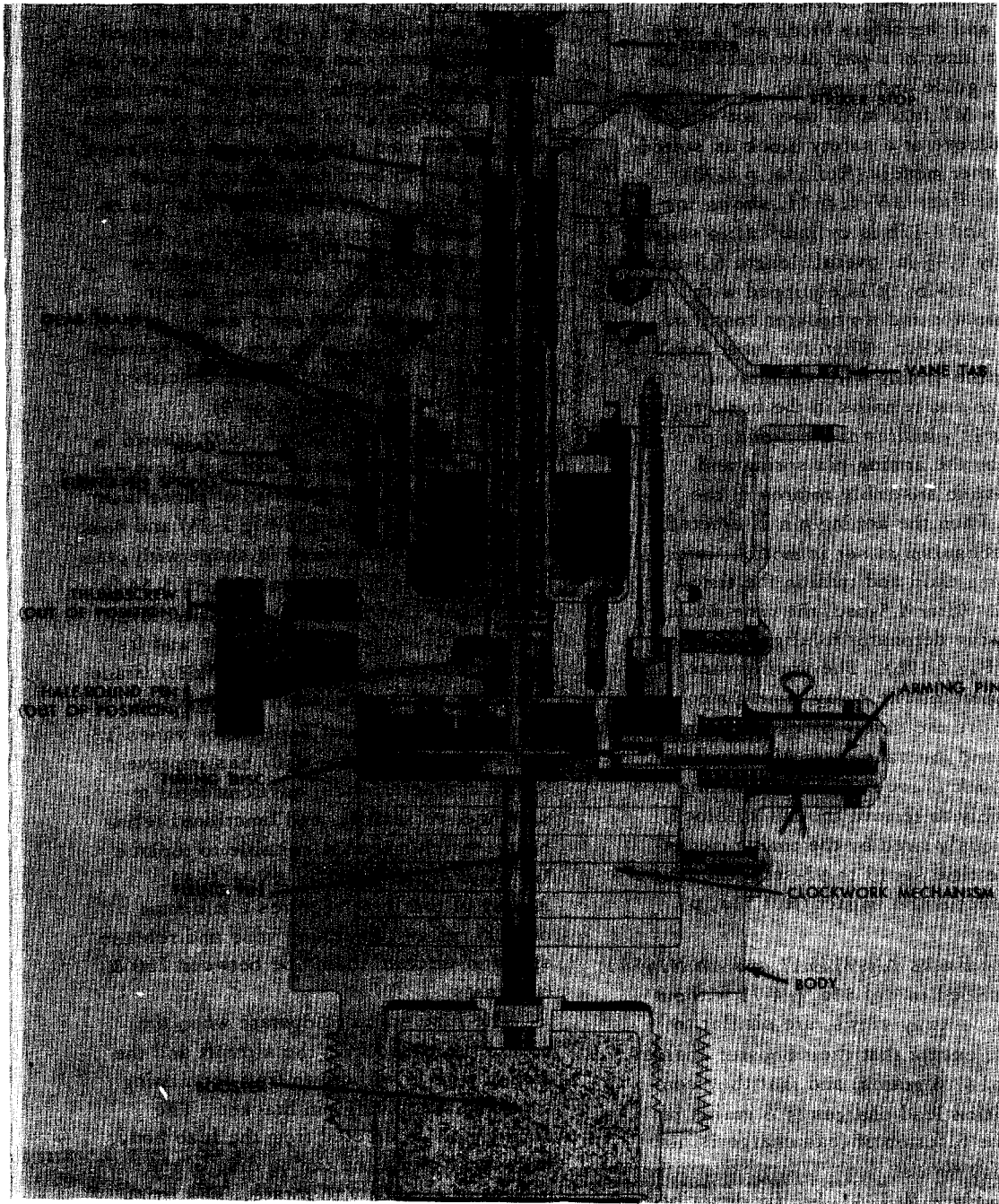

Fig 4-18 BOMB NOSE MT FUZE, M155A1

gear to line up with the top of the arming stem. Rotation of the arming gear is accomplished by rotation of the reduction gears of the gear train. When the slot in the arming gear aligns with the head of the

arming stem, the arming stem moves upward thru the arming gear slot. The slider, containing stab primer, moves the firing train position, thus making the primer align with the firing pin & booster. The slider is held in the

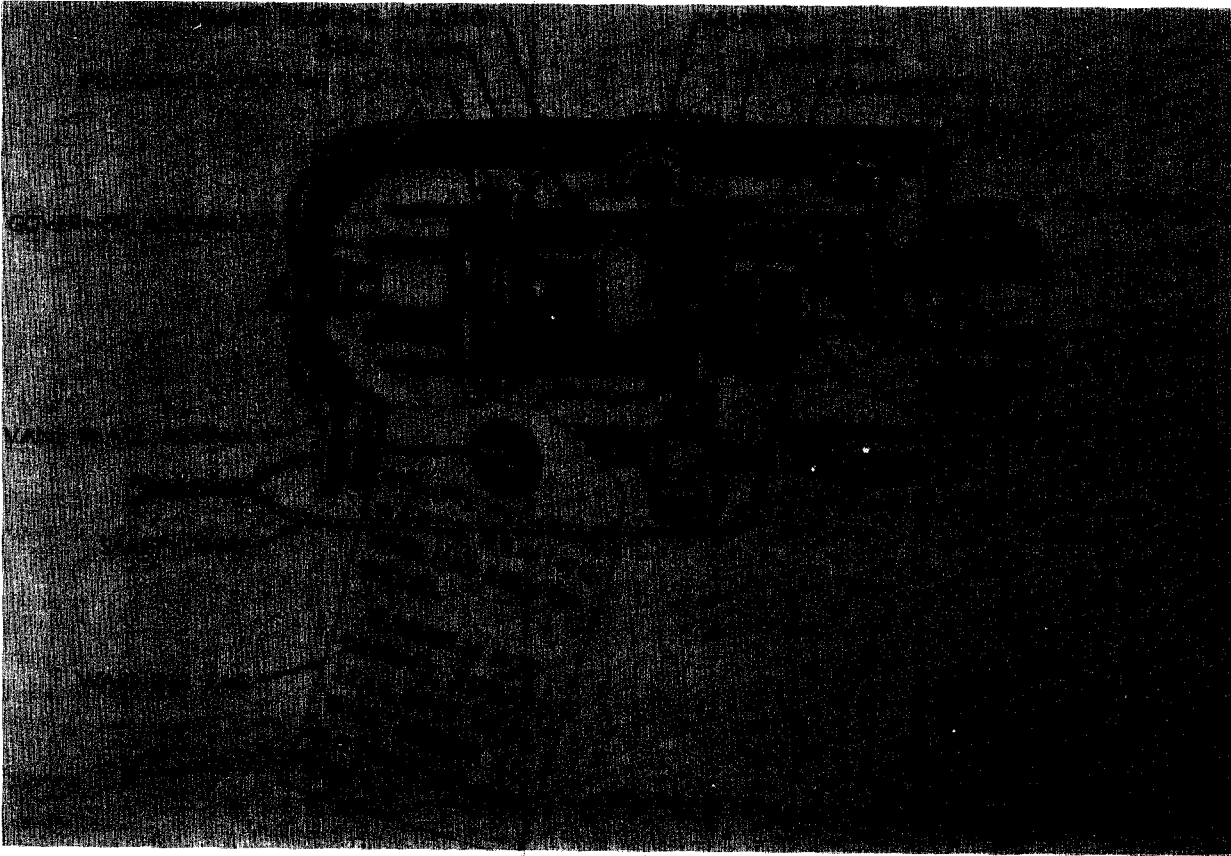

Fig 4-19 BOMB NOSE (or TAIL) MT FUZE, M907

armed position by a spring-loaded slider lock

Ejection of the arming pin from the slot in the timing disc allows the clockwork of movement assembly to start. This starting is assured by a spring-loaded starter, which sweeps across an escape wheel, and imparts motion to it. The timing lever rides on the edge of the timing disc until it rotates into the slot of the timing disc from which an arming pin is ejected. Rotation of the timing lever causes release of the firing lever which, in turn, releases the cocking pin. Release of this pin causes release of the spring-loaded firing pin, thus allowing it to strike the primer in order to initiate the expl train of the fuze (Ref 51a, pp 4-80 to 4-83)

Nose (or Tail) MT Fuze M908 is similar to M907, except that its booster assembly contains a Tetryl lead and Tetryl booster

(while M907 has a BkPdr booster) and its detonator is M19A2 instead of primer M72 used in M907. Fuze M908 replaces MT fuzes AN-M145A1 and M152A1 for use in aimable clusters (Ref 51a, p 4-84)

Nose (or Tail) MT Fuze M909 is similar to M908, except that it is shorter (5.06-inches in lieu of 6.08-in for M908). Fuze M909 replaces MT Fuze AN-M147A1 for use in aircraft parachute flares, aimable fragmentation clusters and leaflet bombs (Ref 51a, p 4-84)

Section 6, Part C

d) Bomb Proximity or VT (Variable Time) Fuzes

Proximity (VT) fuzes are automatic time fuzes which, without setting or adjustment, detonate the bomb on approach to the target at the most effective point on its trajectory. They are essentially radio transmitting and receiving units. In flight, the

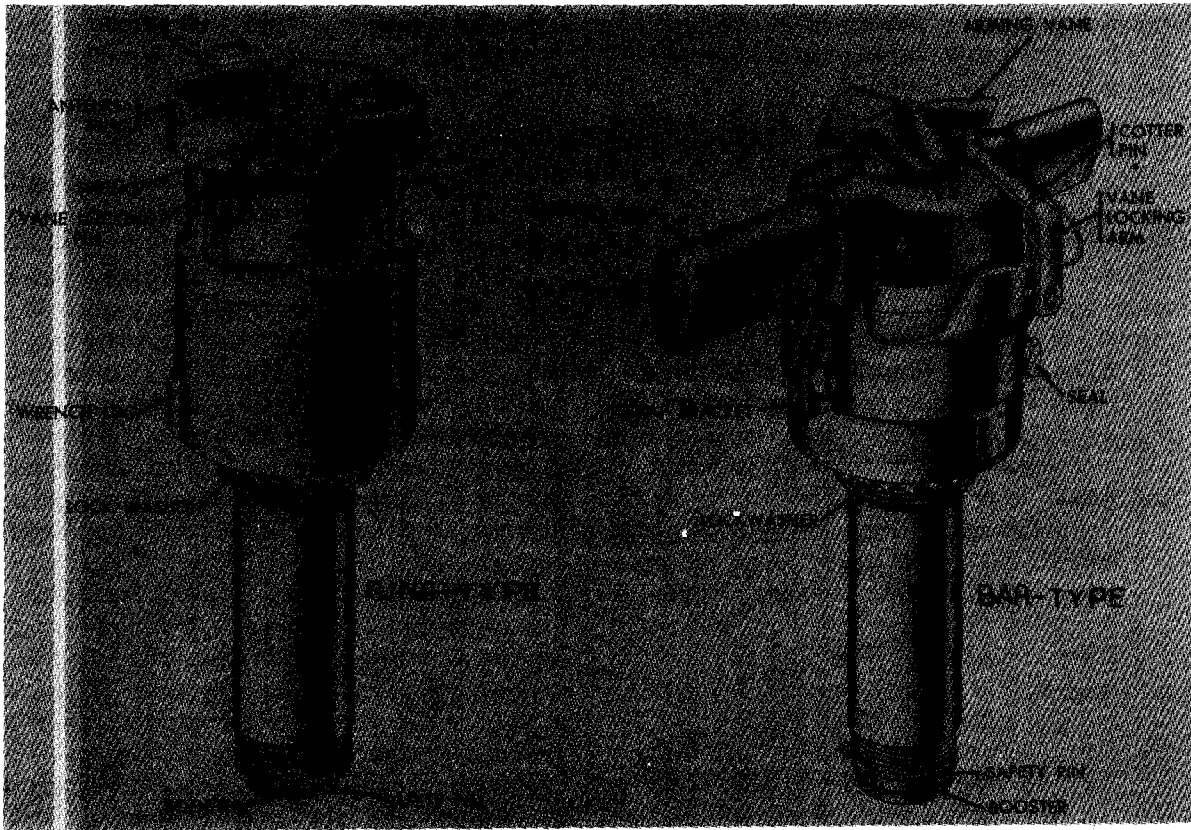

Fig 4-20 BOMB NOSE PROXIMITY (VT) FUZES
(Ring Type and Bar Type)

fuze transmits a radio signal which is continuous. When this signal is reflected from any object to the armed fuze, it interacts with the transmitted signal to produce ripples or beats. When the beat reaches a predetermined intensity, it trips an electronic switch which permits an electric charge to flow thru an electric detonator. Proximity fuzes may profitably be employed in any operation in which air burst at heights between 10 and 250 feet will increase the effectiveness of the bomb in which it is used. These fuzes are similar to time fuzes in production of air burst, but the time fuze is governed by distance from the origin, while the proximity fuze by its proximity to the target

There are two types of proximity (VT) fuzes, the **bar-type** and the **ring-type** (Fig 4-20). The bar-type fuze can be used effec-

tively in any bomb with a fuze well that will accommodate nose fuze M163, while the ring-type, although it fits the same fuze well, can be used only in the bomb sizes for which it is specified. In both types, the external part of the fuze body is a cylinder 3 to 4-inches in diameter and 5-inches long, with a vane at the nose. The ring-type has a metal ring surrounding the vane with a vane stop pin sealed in the ring. The bar-type has two 4-inch antenna bars (dipoles) extending radially from the head, and a vane-locking arm mounted on a bracket on the side. In both types, the part of the body which is assembled within the bomb conforms in size and shape to nose fuze M163, except that there is a safety pin clipped around the base and extending into the end of the fuze. This safety pin is never removed until just before assembling the fuze to the bomb

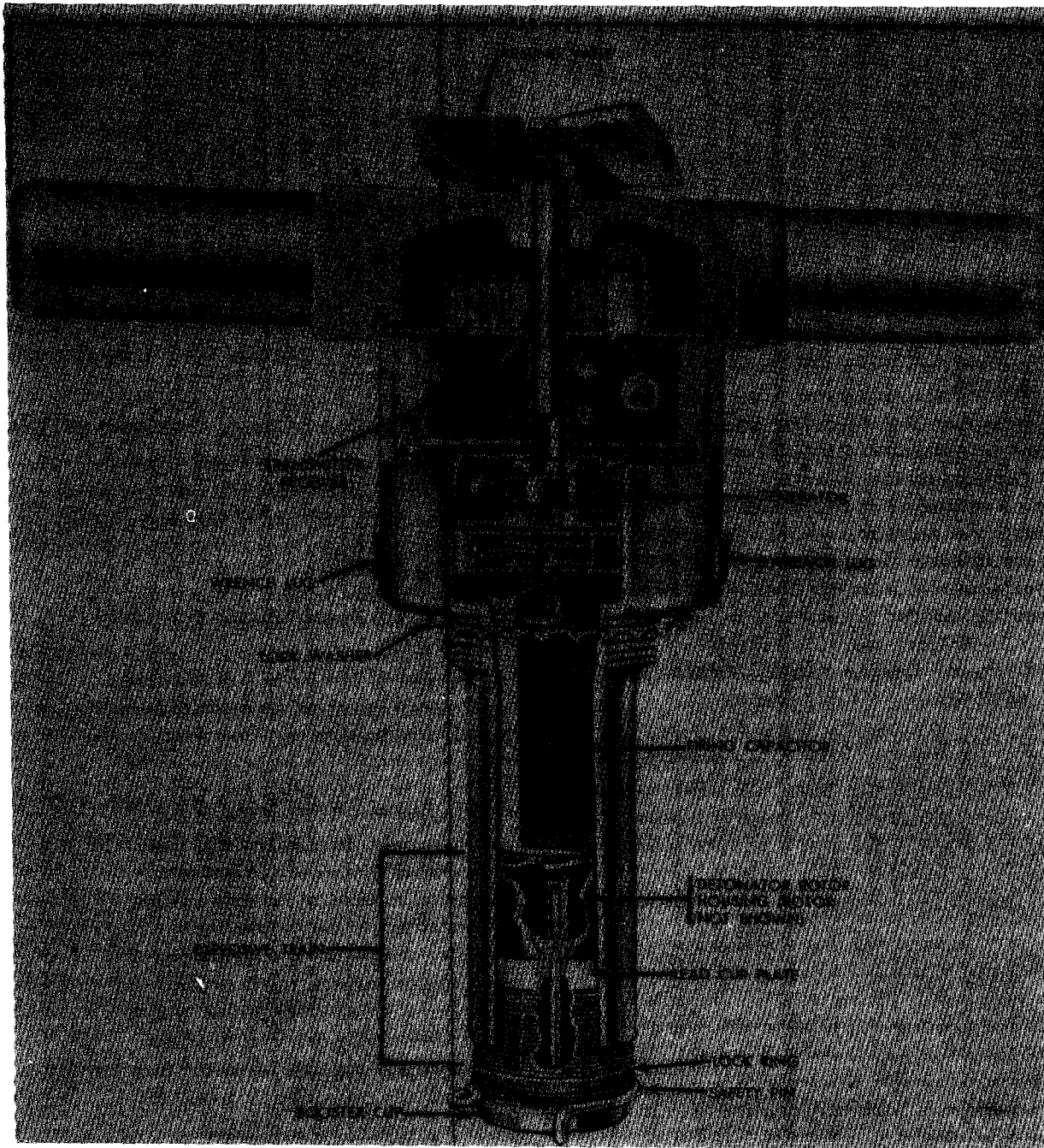

Fig 4-21 BOMB NOSE PROXIMITY (VT) FUZE, AN-M166

Functioning. The arming vane drives a high speed (coupling) shaft and, thru a reduction gear train, a slow speed shaft. An electric generator is mounted on the high speed shaft which furnishes power to

charge a firing capacitor and to operate the transmitting and receiving unit which controls the electronic switch between the firing capacitor and shaft by a spring-loaded pin. The rotor controls both mechanical

and electrical arming; it keeps the detonator out of line with the booster lead, and it keeps the detonator out of contact with the firing circuit, until arming is complete. As the rotor is turned to the armed position, the outer end of the key pin is driven by its spring into a recess in the rotor housing while the inner end withdraws from the keyway in the shaft. When a material object enters the zone of influence of the fuze, the reflected wave causes the firing switch to operate, passing the charge of the firing capacitor thru the electric detonator, thus initiating the explosive train. Since these fuzes operate on any object, airborne *minimum-safe air travel* (MinSAT) is carefully calibrated for the protection of friendly planes. The MinSAT is measured for representative samples of each lot of proximity fuzes and is marked on every fuze of the lot. Mechanical arming-delay devices, by means of which MinSAT can be increased by as much as 20,000 feet, must be used with these fuzes. Air travel arming-delay device M1A1 (or M1) is used for this purpose

While only three models of the bar-type and one of the ring-type have been standardized, addnl experimental models have been issued. A list of current US VT fuzes giving their applications in various bombs is in Table 4-20, p 4-87 of Ref 51a

Nose Proximity Fuze AN-M166 (T51E1), shown in Fig 4-21, is of the bar-type. It can be used in any bomb that contains a fuze well that will accommodate a selective action nose fuze in the series M163 (described in Ref 51a, pp 4-1 & 4-2) or M904 (described in Ref 51a, p 4-21 and shown in Fig 4-4). This VT fuze can also be used with any GP, Frag or Chem bomb weighing 100-lb or more which takes nose fuze AN-M103A1 (shown in Fig 4-1) or M163. The nominal MinSAT of this VT fuze is 3600-ft. It is extremely sensitive and its tactical use is independent of height of release, speed of aircraft or type of terrain (Ref 51a, pp 4-88 & 4-89)

Nose Proximity Fuze M166E1 is a bar-type and is similar to AN-M166, except that its MinSAT is 2000-ft, and some minor

details of construction are different (Ref 51a, pp 4-89 & 4-90)

Nose Proximity Fuze M166E3 is a bar-type and is similar to AN-M166, except for some minor details. It may be used with GP, Frag & Chem bombs of 100-lb and higher (Ref 51a, p 4-90)

Nose Proximity Fuzes M168E1 and AN-M168 are ring-type and differ from bar-type VT fuzes as shown in Fig 4-21. Their nominal MinSAT is 2000-ft (Ref 51a, p 4-90)

Nose Proximity Fuze M188 (T765) is a bar-type and resembles M163A1 fuze. Its nominal MinSAT is 3600-ft (Ref 51a, p 4-90)

Nose Proximity Fuze T51 is a bar-type and may be used with GP, Frag & Chem bombs of 100-lb and higher (Ref 51a, p 4-90)

Nose Proximity Fuzes T89 and T90 are ring-type and may be used in GP, Frag & Chem bombs of 100-lb & higher (Ref 51a, p 4-90)

Nose Proximity Fuze T93 is a ring-type and may be used to fire on approach to both ground and airborne targets. When used against ground targets, burst heights of the fuze are the same as for other ring-type fuzes. When the fuze is conditioned for air-to-air use, bomb detonations will take place after about 7500-ft of vertical fall from horizontal release, if the fuze has not been activated by passing within the influence range of an aircraft target during the drop. In this respect, the fuze has self-destruction action. The fall of 7500-ft will apply after arming-delay M1 or M1A1 has functioned and separated from the fuze (Ref 51a, p 4-90)

Section 6, Part C

e) Hydrostatic Bomb Fuzes

Hydrostatic fuzes act under the influence of water pressure to explode a bomb at a predetermined depth when used against submarines or other underwater targets

Hydrostatic Tail Fuzes AN-Mk230Mods 4, 5 and 6 described in Ref 51a, pp 4-91 to 4-95 and shown here in Figs 4-22 and 4-23 are vane-arming types. They are bottle-

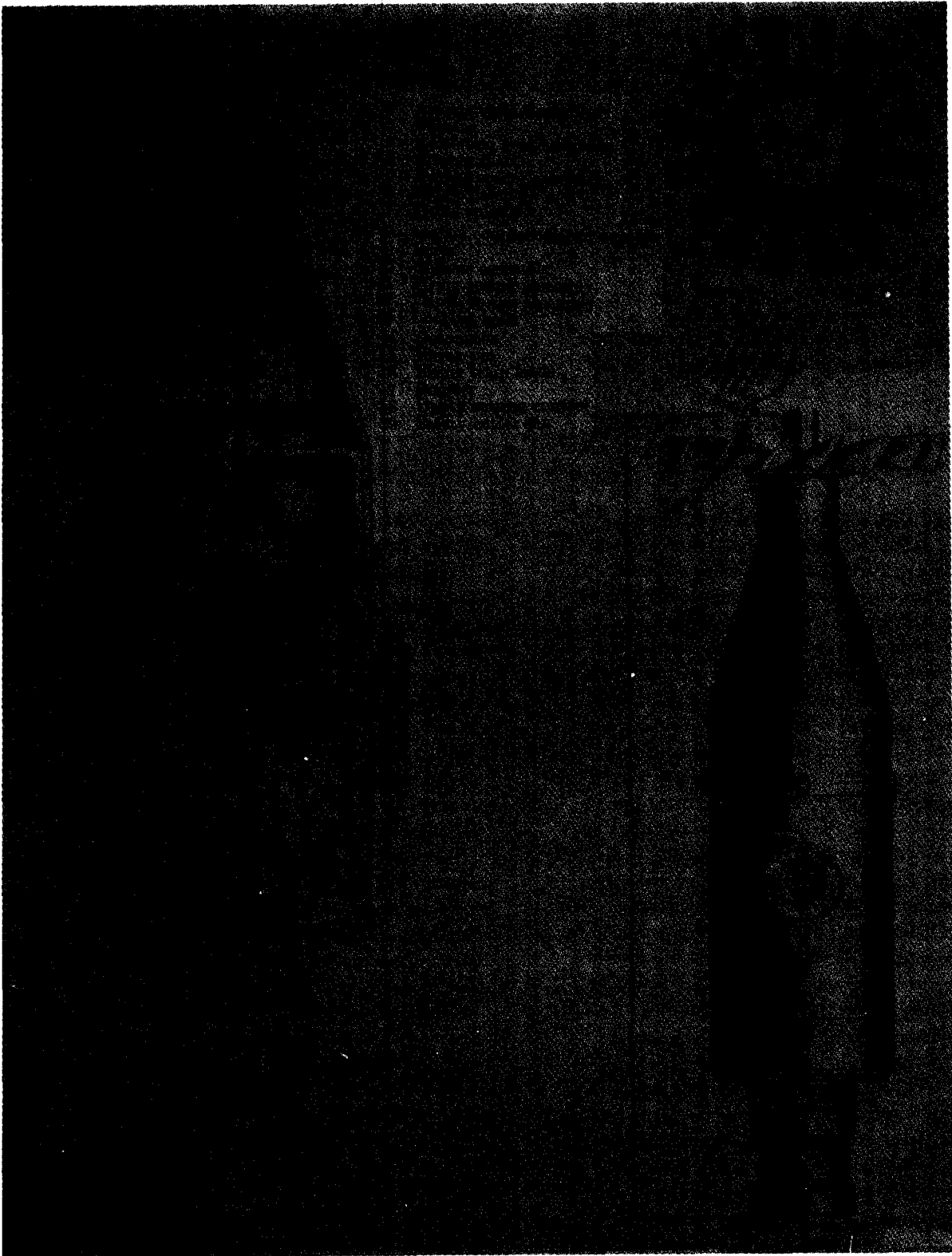

Fig 4-22 BOMB TAIL HYDROSTATIC FUZE, AN-Mk 230

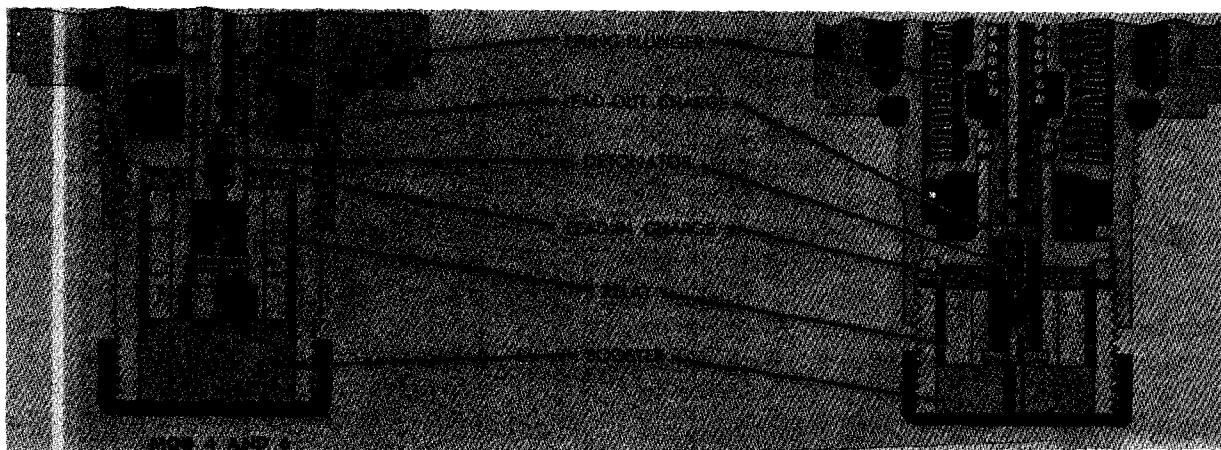

Fig 4-23 BOMB TAIL HYDROSTATIC FUZE, AN-Mk230
(Comparison of Boosters)

shaped with the booster (17) to the base and a 16-blade arming vane (1) assembled to the opposite end. An arming-vane lock flange is assembled at the neck and the depth-setting disc (18) and the lock are assembled to the side. Depth settings (in feet) are engraved in the disc with the lock serving as an index. As issued, a safety (cotter) pin (19) with pull ring and instruction tag, is positioned in the arming-vane lock and a safety bar is held in place thru the fuze threads by a safety (cotter) pin. This bar keeps the detonator assembly from moving toward the firing pin

All fuzes AN-Mk230 have the same dimensions: body diameter 3.38-inches, overall length 15.4-in, and vane span 5.25-in. They weigh 15-lb and their Tetryl booster charges are 22 grams for Mods 4 & 6 and 13 g for Mod 5. There is a slight difference in construction of their boosters and the lengths of relays as can be seen from Fig 4-23. Their firing delays are determined by depth settings at 25, 50, 75, 100 & 125-ft. While Mods 5 & 6 have the accuracy of their 25-ft setting emphasized, Mod 4 has the accuracy of 50-ft setting emphasized

When the bomb is dropped, the arming wire is withdrawn (being retained on the rack), the airstream starts to rotate the arming vanes (1) and bushing (2) (See Fig

4-22). The rotation is transmitted thru a reduction-gear train (3) to the arming shaft (4) which is threaded into the arming-spider assembly (5). This assembly progresses upward and, after 110 revolutions of the vane, clears the safety detents (6) which are ejected by their springs from the groove in the head of the firing spindle (7). Upon impact with water, the inertia counterbalance weights (8) prevent function by set-forward. As the bomb sinks, the water enters the ports (9) in the body and builds up hydrostatic pressure in the bellows (10). When sufficient pressure [preset by depth setting control (18)] builds up to compress the firing spring (11) and depth spring (12), the firing spindle is forced downward so that the locking balls (13) fly into a recess and the firing spring forces the detonator (14) against the fixed firing pin (15). The resulting expln is transmitted thru the firing train lead (16) (consisting of lead-out charge, lead-in charge and relay) to the booster (17), which sets off the filler of the bomb

These fuzes are also described in Ref 19b, pp 133-37

Section 6, Part C

f) Nonstandardized Bomb Fuzes

This section pertains to fuzes with physical and functional characteristics

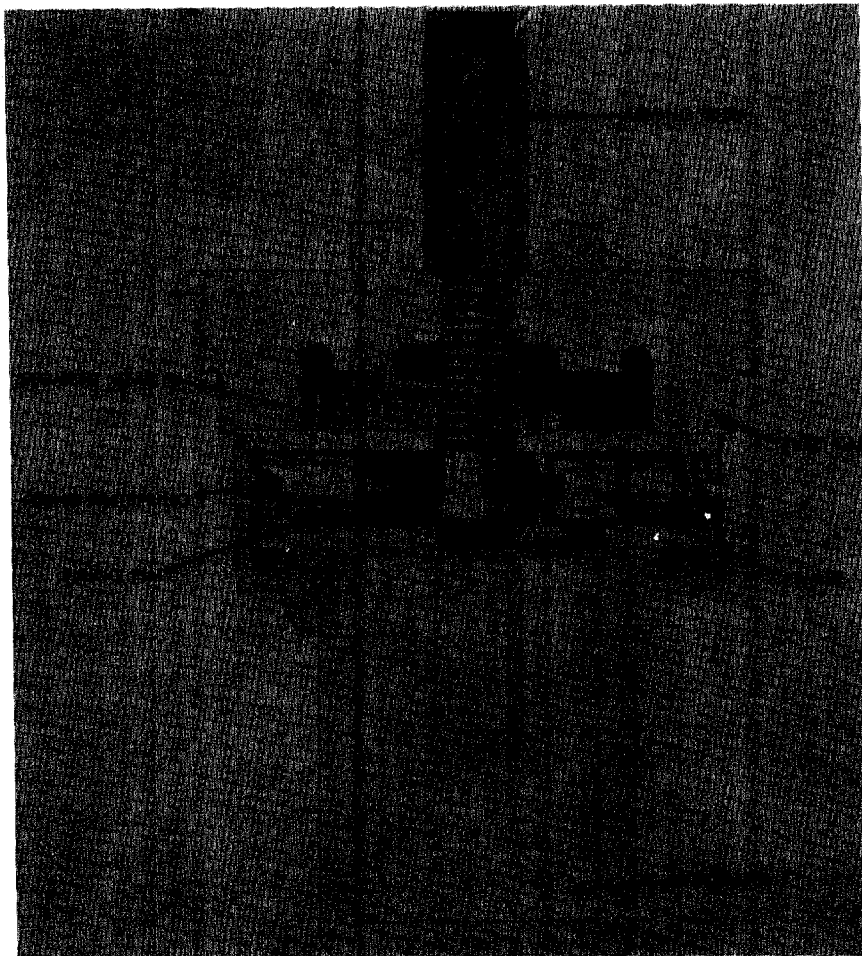

Fig 4-24 BOMB NOSE MT FUZE, M129

and specialized application which do not allow their being classified as a standard series or type

Bomb Nose (or Tail) Fuzes FMU-7/B or FMU-7A/B are designed for use on later models of fire bombs. Two identical fuzes are employed in the nose and tail of each bomb. Electrically armed and impact fired, they are used in conjunction with FMU-7 initiators and cable assemblies

After release of the bomb from the aircraft, an electrical pulse from the FMU series initiator in the bomb operates a motor bellows in each fuze, which results in their arming. Upon ground impact, an all-ways-functioning striker assembly initi-

ates a primer, and a primer-detonator, which, in turn, cause detonation of HE booster and incendiary filler of the bomb (Ref 51a, p 4-96; no cutaway view is given)

Bomb Nose MT Fuze M129 (Fig 4-24), designed for aerial burst or impact, is used only with the fragmentation (butterfly) bombs assembled in clusters. Its body diam is 1.75-in, overall length 3.0-in, and wt 0.4-lb. It is equipped with primer M41A1, detonator M31, and booster contg Tetryl pellet in a metal cup

When the bomb equipped with M129 fuze is released from the cluster, the butterfly wings snap open and ride to the top of the cable attached to the arming stem. The

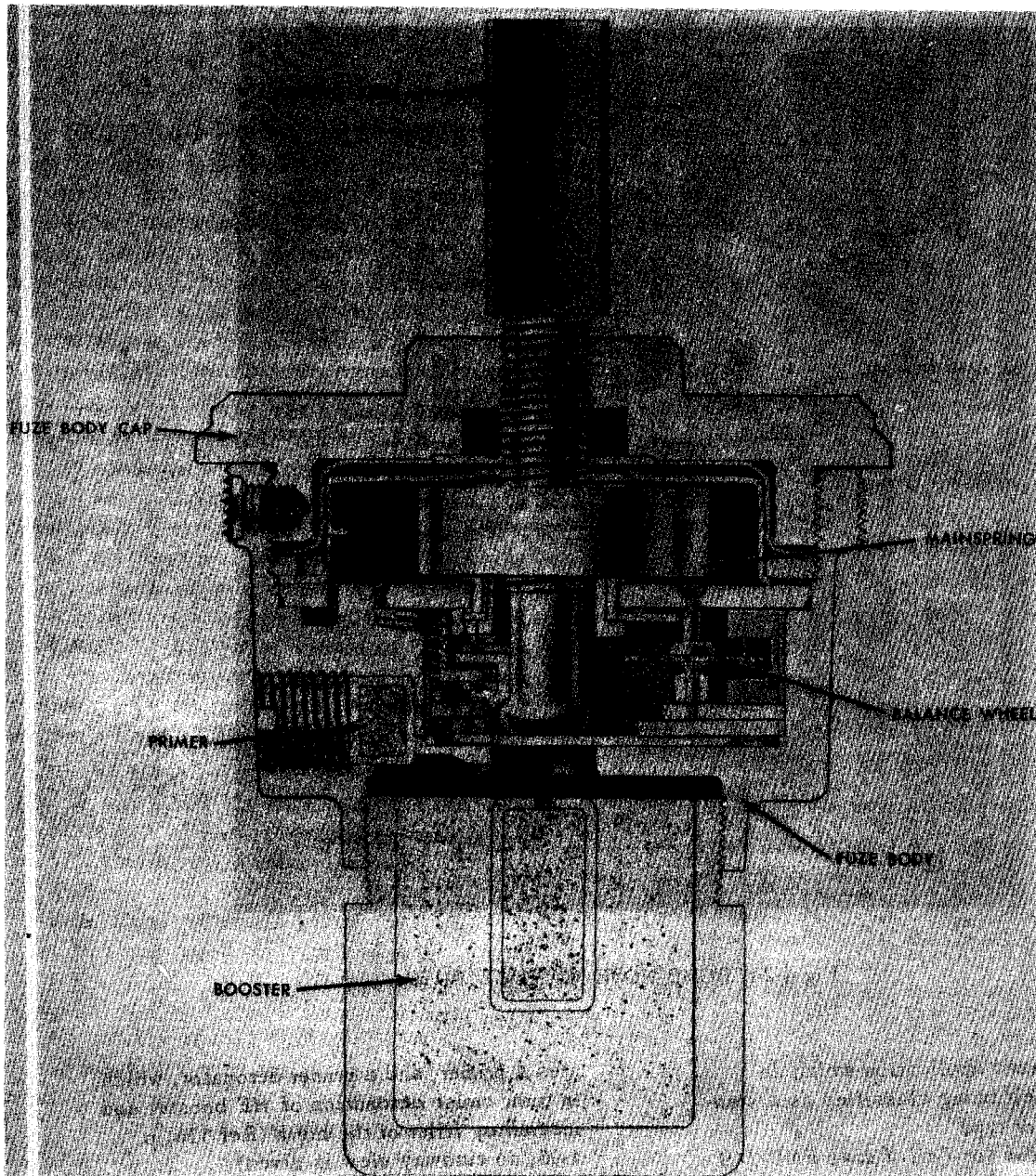

Fig 4-25 BOMB NOSE MT FUZE, M130

rotation of the wings in this position causes the cable to turn, unscrewing the arming stem far enough to initiate the arming mechanism of the fuze. This action requires 3.5 to 5.0 revolutions of the wings and ca 50-ft of air travel. If the fuze has been pre-set for "AIR" burst, it will detonate 2.5-secs after the arming action is completed. If the fuze has been set for "GROUND"

burst, it will not detonate until impact

Detailed description of its arming and functioning is given in Ref 51a, pp 4-97 to 4-100 (Compare with fuzes M130A1 and M131A1 described below)

Bomb Fuze M130A1 (Fig 4-25), is a mechanical-time type, with body diam 1.75-in, overall length 3.14-in, and wt 0.4-lb. It is equipped with primer M41A1, detonator

M31 and Tetryl pellet booster. Designed for use with the fragmentation (butterfly) bomb, it can be set either for "GROUND" action (by impact) or for "AIR" burst, pre-set for delays 10, 20, 30, 40, 50 or 60 minutes after arming. Arming takes place after 50-ft of air travel

Detailed description of its arming and functioning is given in Ref 51a, pp 4-101 to 4-104 (Compare with M129A1 and M131A1 fuzes)

Bomb Nose MT Fuze M131A1 (Fig 4-26) is designed for use only with fragmentation (butterfly) bombs assembled in clusters. Its dimensions, weight, primer, detonator, and booster are identical with those of M130A1 fuze. The fuze is provided with an antidisturbance device which is very sensitive and, when the fuze is fully armed, the bomb is very dangerous to handle; and no attempt should be made to disarm it. If the fuze is suspected to be armed it should be destroyed by bomb disposal personnel. As this fuze is the latest of the three similar fuzes (M129A, M130A1 and M131A1), its detailed description, which is given in Ref 51a, pp 4-105 to 4-107, is included here

When the fragmentation bomb is released from its cluster, the butterfly wings snap open and ride to the top of the cable attached to the arming stem. The rotation of the wings in this position causes the cable to turn and unscrew the arming stem, initiating the steps in the firing action. When the arming stem has risen approximately 1/8-inch, the fuze is considered armed. After completion of approximately 50-feet of air travel, the arming stem has risen about 1/4-inch. This allows the first release in the arming action, which requires about 1/2-second to take place. The second release occurs upon impact. The force of impact is utilized to prepare the antidisturbance device of the fuze for action. This phase of the firing sequence is completed 2-seconds after impact. After the second release, the fuze is in the extremely sensitive state. Should it be subjected to handling, shock, or vibration, the antidisturbance device will be

released and the fuze will detonate

Arming. When the arming stem has risen approximately 1/8-inch by action of the butterfly wings, it has been withdrawn from its original position between the firing pin and the primer. In this condition, the fuze is considered armed

Action. When the arming stem has risen 1/4-inch, its inner end has cleared the escape-wheel spring and the timing gear, freeing them. The released timing gear is rotated in a clockwise direction under the force of the coil drive spring. The speed of the timing gear is controlled by the escape movement (gear train, escape-wheel spring). After about 1/2-second, the stud on the inner surface of the timing gear contacts a projection on the second release weight (impact spring), bringing the entire mechanism to a halt and completing the first release. This condition exists until impact. Upon impact, the second release weight deflects, disengaging the impact spring and the impact-spring stud. The timing gear again rotates under action of the coil-drive spring until a stud on the outer edge of the timing gear contacts the small projection at the end of the antidisturbance block. Here the timing mechanism is once more brought to a halt and the fuze is prepared for its antidisturbance phase. The time delay after the second release allows the antidisturbance block to damp out the oscillation caused by impact. The second release time is about 2-seconds

Detonation. The firing pin sets off the primer which relays the explosion to the detonator. The detonator explodes the booster which, in turn fires the bomb

Delay Generator Fuze M220, used in Cluster, Generator: Incapacitation, BZ, 175-lb, M44, is an ignition-type fuze with a delay housing extending from the primer to the ignition pad on the alignment plate between the top and middle tiers of canisters. The delay housing contains a first-fire mixture, a delay element and an ignition mixture (Ref 51a, p 3-20). No drawing is given here

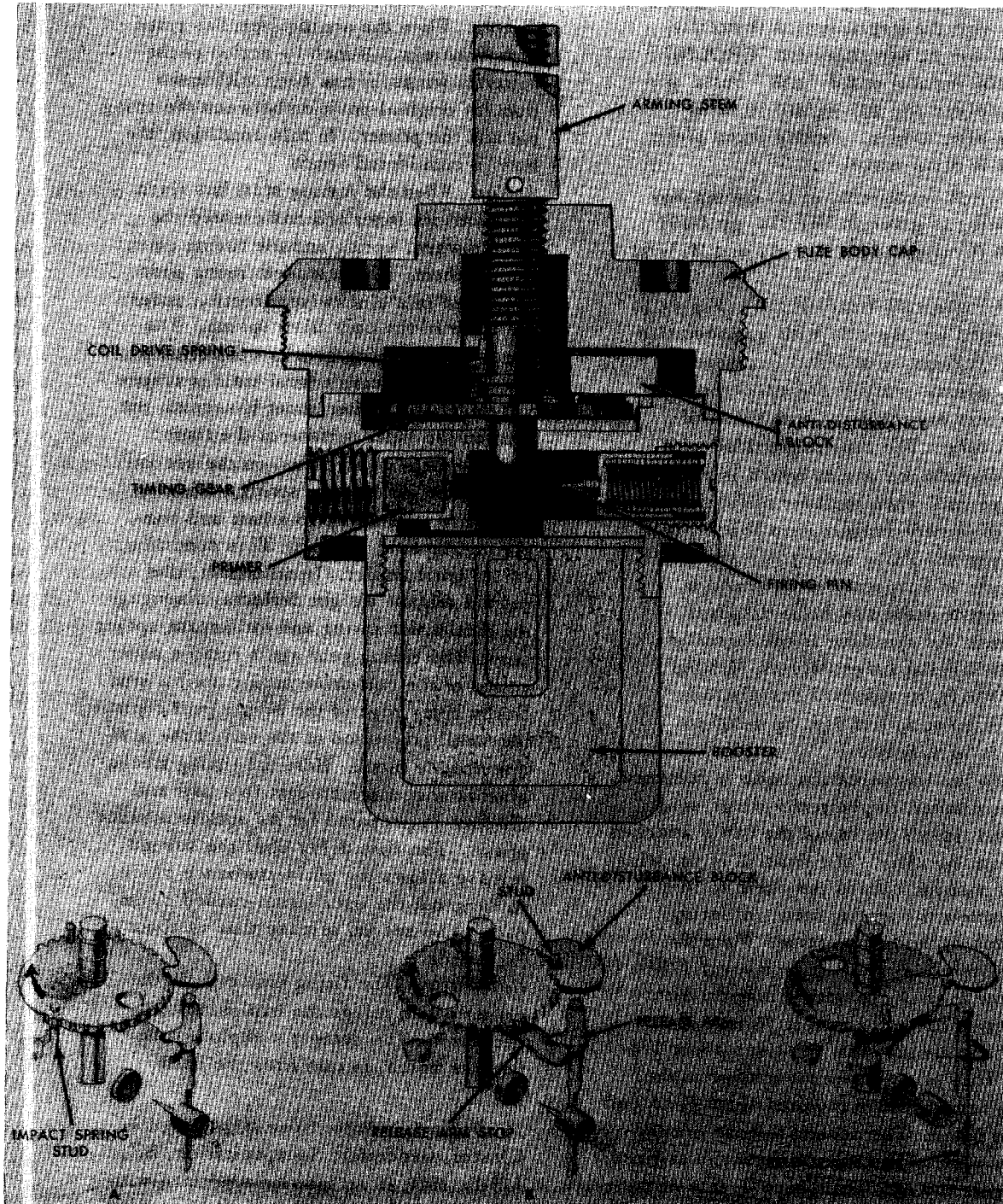

Fig 4-26 BOMB NOSE MT FUZE, M131A1
(Cross Section and Detail of Operation)

Section 6, Part C

g) Pyrotechnic Bomb Fuzes

Fuzes used in pyrotechnic devices are of two kinds: those which are an integral part of a device and those shipped separately for use with parachute flares. Only the fuzes which are shipped separately are described in TM 9-1370-200 (1966) (Ref 51c), pp 3-5-57 to 3-65. These fuzes are nose fuzes of the mechanical-time delayed-arming type (vane armed, pin initiated, or anemometer)

The following fuzes are described in Ref 51c:

Bomb Nose Fuze, M111A2 is similar in appearance (but shorter in length) and operation to the fuzes AN-M146-series (shown here in Figs 4-27 & 4-28), except for the absence of the detonator slider and its cover plate and lock pin assembly. Its percussion primer is always in line with the firing pin. This fuze, therefore, is not detonator safe (Ref 51c, pp 3-59 & 3-60)

Bomb Nose Fuzes, AN-M146 are MT fuzes of the combined vane-armed, pin-initiated type. The impact element constitutes a self-destroying feature which operates only when the time setting exceeds the time of flight or in case the time mechanism fails to operate

The fuze consists (See Fig 4-27) of a *head*, which contains the mechanical arming and firing assembly, and a *body*, which contains the time element and the explosive train. The head and the body are held together by a spring-steel ring which is compressed by three screws in the fuze body. Variation of screw pressure provides adjustment of the torque required to set the fuze. A time setscrew (T) is provided to lock the head in position after the setting has been made. The arming pin (H) and arming wire guide (F) are assembled on the side of the body opposite the time setscrew. A slider cover plate (J), screwed to the body near its lower end, closes one end of the detonator slider assembly (Z). A large screw (K), 90° around the body from the slider cover plate, holds the detonator slider lock pin and spring in place. An index mark (set line) for time setting

is engraved on the body just below the head. The time graduations are engraved around the base of the head, and two stop pins are set in the time scale so as to butt against the arming wire guide at maximum and minimum time settings. The arming hub, with vane assembly (D), arming sleeve (L), and firing pin (N) with striker (A) project thru the forward end of the head. A C-shaped safety block (C) is held in place between the striker and the vane nut (M) by the arming sleeve. The safety block has a collar which bears on two pins in the vane nut. The collar bearing on the pins insures that the safety block will spin with the arming vane and develop sufficient centrifugal force to throw the block clear when the arming sleeve is withdrawn. As the fuze is issued, there is a forked striker stop (B) in place between the striker and the safety block and a cotter pin (G) thru the inner pair of eyelets in the arming pin. These are connected by a sealing wire which also passes thru the inner pair of eyelets in the arming wire guide and vane tab (E). The arming hub has a stationary gear (Q) in mesh with a fixed pinion (S). A movable gear (R) of the arming sleeve is also in mesh with the pinion. The movable gear (34 teeth) has one more tooth than the stationary gear (33 teeth). The spring-loaded firing pin (N) is held in place by a half-round pin (U), which cannot turn, since its peg is hooked by the firing lever. The firing lever, in turn, is held by the timing disk lever (trigger arm), which rides on the edge of the timing disk (V). The timing disk has a notch in which one end of the arming pin rests and into which the timing disk lever drops after removal of the arming pin and rotation of the disk occurs. A spring-wound clockwork timing mechanism (X) acts to turn the timing disk. Below the timing disk and attached to the same shaft is a cam which restrains a detonator slider arming stem (W). This arming stem has a half-round section at its lower end which, in the unarmed position, rests against a shoulder of the spring-loaded detonator slider (Z). The detonator slider, containing the detonator (Y), has a notch in its

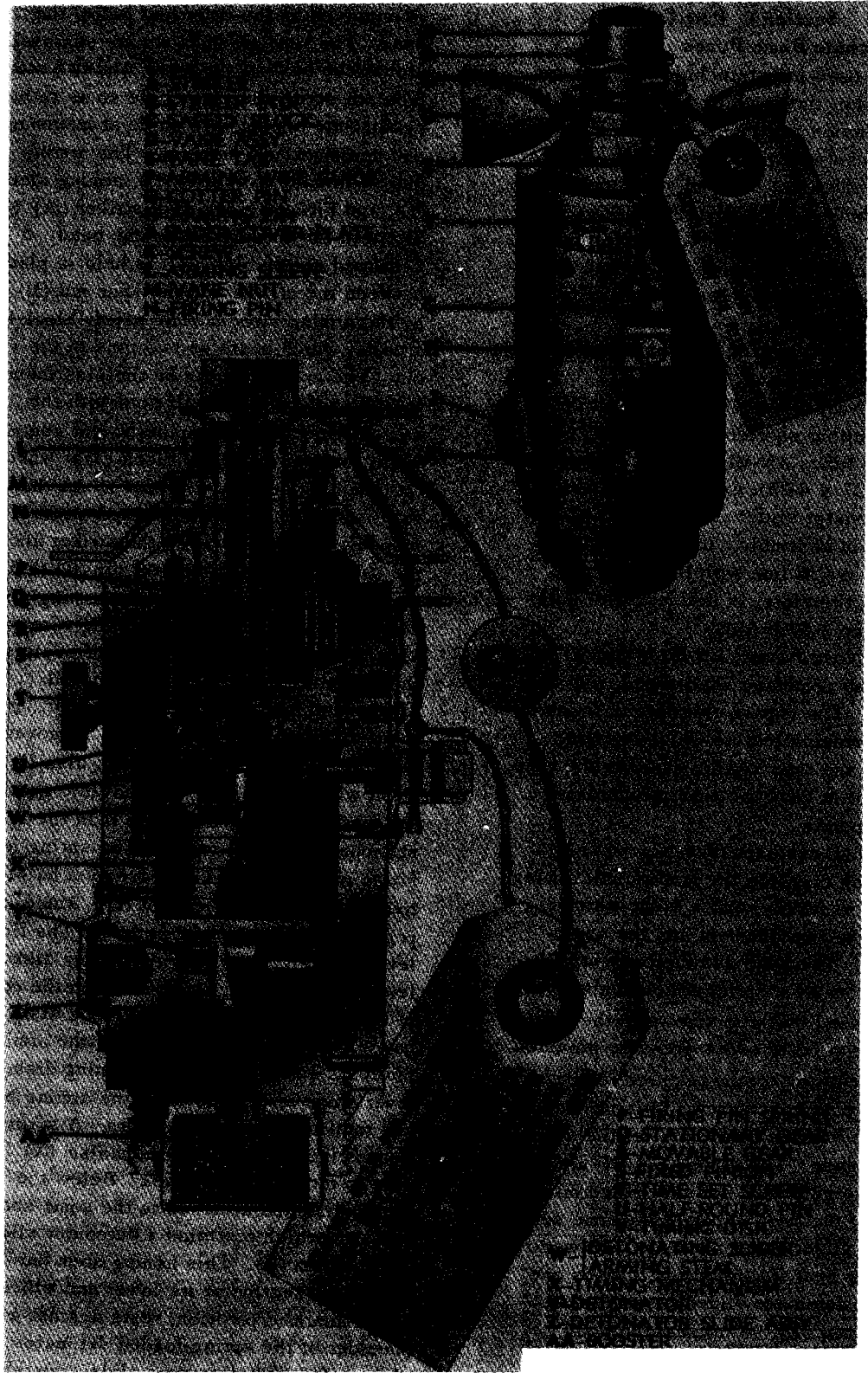

Fig 4-27 PYROTECHNIC BOMB NOSE FUZE, AN-M146A1

D 1007

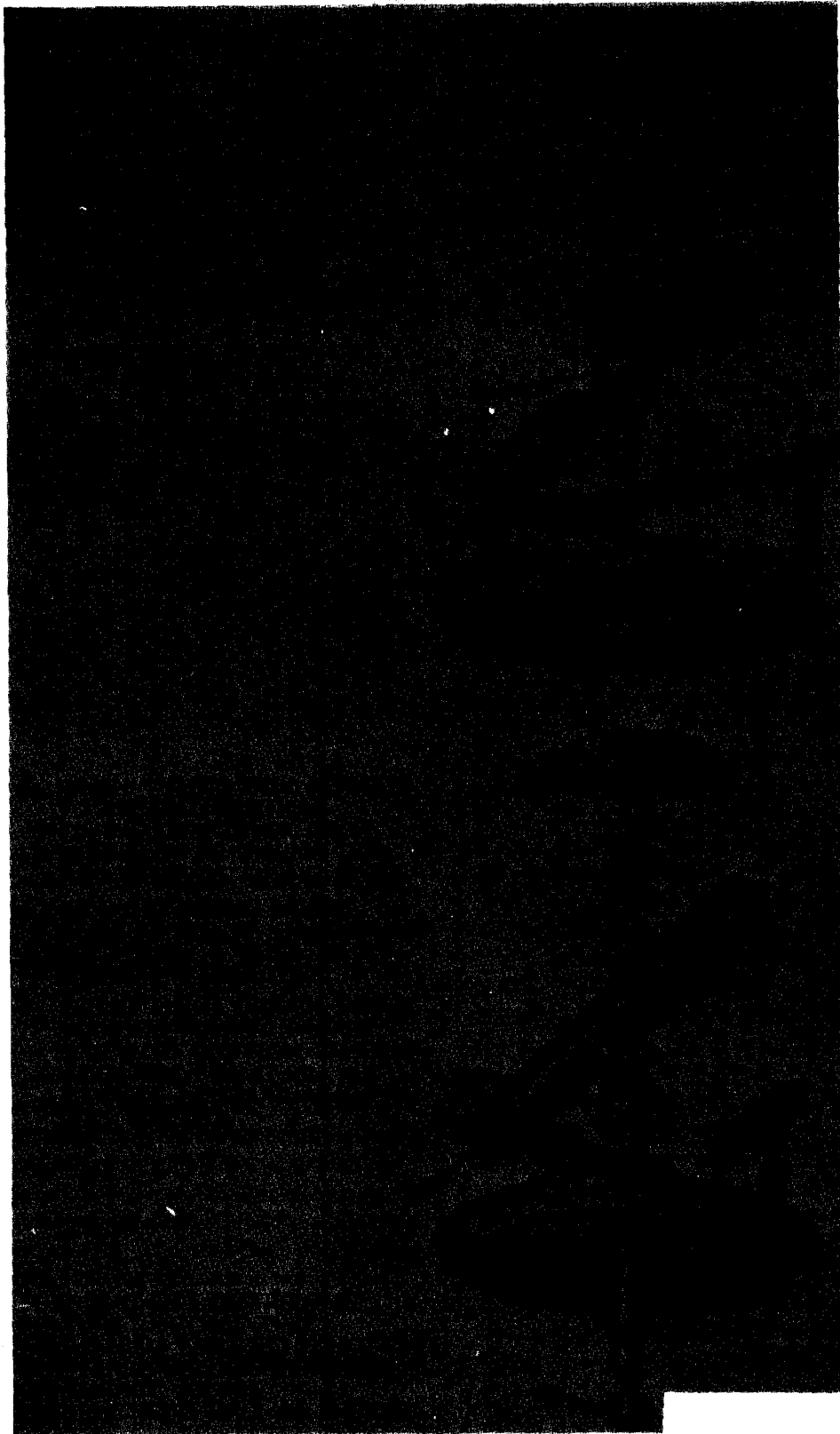

Fig. 4.28. PYROTECHNIC BOMB NOSE FUZE. AN M16A1

side to receive the spring-loaded lock pin. A BkPdr booster (AA) is housed below the detonator assembly

Operation of fuze: The fuze is set for time desired and prepared for dropping. Turning the head to the desired time locates the timing disk lever at such distance from the notch in the timing disk as will give the time desired. Upon dropping of the flare, the arming wire is withdrawn from the arming pin and arming vane. The arming pin is ejected by its spring, thereby releasing the timing disk which is turned by the time mechanism at a uniform rate until the timing disk lever (trigger arm) drops into the timing disk notch (Fig 4-28). The movement of the timing disk lever releases the firing lever which permits the firing pin to move downward against the half-round pin which is now free to rotate. When the cam, turning in conjunction with and located below the timing disk, rotates sufficiently, it turns as arming-stem which releases the detonator slider, since its half-round section no longer restrains the shoulder of the slider. When the slider moves to the armed position, the lock pin moves into the corresponding notch in the slider. This action takes place 4.5-seconds after the arming pin of the fuze is released. The firing pin cannot come down to fire the detonator until the C-shaped safety block, held by the arming sleeve, has been thrown off by centrifugal action. When the arming vanes rotate, the stationary gear, having 33 teeth, rotates the fixed pinion which, in turn, rotates the movable gear having 34 teeth. Since the movable gear lags one tooth each revolution, it unscrews the arming sleeve from the hub, withdrawing the sleeve from the safety block. When the sleeve is completely withdrawn, the safety block falls away and the fuze is armed. If impact occurs before the set time expires, the firing pin is driven in, shearing the trigger mechanism, and firing the detonator (Ref 51c, pp 3-60 to 3-65)

Section 6, Part C

h) Inert Bomb Fuzes

Inert fuzes are provided for training ground crews in assembling & handling of bombs, and also for classroom instruction of ordnance personnel. These fuzes are standard items, except that explosive components (primers, detonators, delay & relay elements and boosters) are removed (Ref 51a, p 4-107)

Section 6, Part C

i) Foreign Bomb Fuzes Used During WWII

1) **British.** In TM 9-1985-1 (1952) (Conf) are described bomb fuzes on pp 245-92, and also *pistols* used in bombs (pp 205-44)

2) **French.** Generally speaking, French bombs of WWII were fuzed in nose or tail (or in both) with mechanical fuzes (i.e., contg strikers and detonators, and with a wind-vane arming device) somewhat similar to US fuzes (Fusée is French for fuze)

The following description is given in TM 9-1985-6 (1953) (Ref 29), pp 187-205: *Types of French Bomb Fuzes:*

a) *Percussion Fuzes.* The arming is effected either by the resistance of air operating vane ("Fusées à helicé") or by the speed of descent ("Fusées RSA" where RSA means "Raymondie sans armement"). Arming is attained after a fall of at least 66 feet

b) *Aerial Burst Fuzes.* They operate either by the action of a vane, after certain number of rotations is reached or by the burning of a powder pellet, the length of pellet determining the time

c) *Time Fuzes* (Clockwork Mechanisms and Fixed Time). These types are for bombs with instantaneous action or delay of 0.05 or 0.15-seconds. In addition to the usual safety device, a supplementary security mechanism called "security largable" is used in some fuzes

The markings of fuzes may include: I - instantanée; SR - "sans retard" (one or two relays, no delay); CR - "court retard" (short delay, 0.05-sec); LR - "long retard" (long delay); SchR-Schneider-Raymondie

Following is a list of French pre-WWII fuzes:

Mechanical Impact Nose Fuze, Type A (pp 190-91)
 Mechanical Impact Nose Fuzes Type H, Models 1921 and 1929 (pp 192-93)
 Nose Impact Fuzes RSA, Models 1925, 1928 and 1929 (p 193-94)
 Nose Impact Fuze RSA Model 1930 (p 195)
 Mechanical Impact Nose Fuze Mbis (p 196)
 Incendiary Bomb Fuzes, Models 1925 and 1930 (p 197)
 Mechanical Impact Nose Fuze (Designation Unknown) (p 198)
 Mechanical Impact Nose Fuzes No 9 and No 10 (pp 199-200)
 Mechanical Impact Nose Fuze Type No 11 (pp 200-201)
 Mechanical Impact Tail Fuze No 3 bis (p 201)
 Mechanical Impact Tail Fuze SchR Model 1938 (p 202)
 Mechanical Impact Tail Fuzes No 7 and No 8 (pp 202 & 203)
 Mechanical Time Fuze Model 1930 (p 204)
 Mechanical Time Fuze VM (p 205)

Note: The meaning of VM is not given in TM 9-1985-6 (Ref 29)

3) German Bomb Fuzes. A complete description of bomb fuzes used by the Germans during WWII is given in TM 9-1985-2 (1953), pp 125-192 (listed here as Ref 27a). This report, as well as some other sources, were used in compiling PATR 2510 (1958) (listed here as Ref 35), where a fairly complete description is given under the following titles:

Aerial Burst Fuzes, pp Ger 1 to Ger 3 with 4 figs
Antibreak-up Fuze, p Ger 7
Antidisturbance Fuze, pp Ger 7 & Ger 8, with 2 figs
Antiwithdrawal Fuzes, pp Ger 8 & Ger 9, with one fig
Dust Fuze, pp Ger 38 & Ger 39, with one fig
Electric Fuzes, pp Ger 40 & Ger 41, with 2 figs
Fuze, Bomb, pp Ger 54 to Ger 57, with 14 figs

Proximity Fuzes, pp Ger 151 to Ger 152 with one fig

Rocket Bomb Fuze, p Ger 164, with one fig

4) Italian Bomb Fuzes. Accdg to TM 9-1985-6 (Ref 29), pp 29-60, the fuzes used during WWII were mechanically operated, except the time fuzes for the 500-kg time bomb. Most of the fuzes functioned upon impact and the principle of arming and functioning was the same for all fuzes. Arming took place during the fall of the bomb and depended upon the rotation of the arming vanes. The primary safety device was a safety pin which was withdrawn before the bomb was dropped

Following are fuzes listed in Ref 29:
 Type A, Mechanical Impact Nose Fuze (p 30)
 Types B and V, Mechanical Impact Nose Fuzes (p 31)
 Types F and W, Mechanical Impact Nose Fuze (p 32)
 Type J, Mechanical Impact Nose Fuze (p 33)
 Type L, Mechanical Impact Nose Fuze (p 34)
 Type M, Mechanical Impact Fuze (p 35)
 Type Q, Mechanical Impact Nose Fuze (pp 35-6)
 Type R, Mechanical Impact Nose Fuze (p 37)
 Type S, Mechanical Impact Nose Fuze (p 38)
 Type U, Mechanical Impact Nose Fuze (p 39)
 Type C and C-1, Mechanical Impact Tail Fuzes (p 40)
 Type E, Mechanical Impact Tail Fuze (p 41)
 Type G, Mechanical Impact Tail Fuze (p 42)
 Type H, Mechanical Impact Tail Fuze (p 43)
 Type K, Mechanical Impact Tail Fuze (p 44)
 Types N, N-1, N-2 and N-3, Mechanical Time Fuzes (pp 44 & 45)
 Types Y and Y-1, Mechanical Impact Tail Fuzes (p 46)
 Type O, Mechanical Impact Tail Fuze (p 47)
 Type P, Mechanical Impact Tail Fuze (p 48)
 Type Z, Mechanical Impact Tail Fuze (p 49)
 Type I, Mechanical Time Nose Fuze (p 50)
 Type X, Electrical Time Nose Fuze (p 51)
 Clockwork Long Delay Nose Fuze (p 52)
 Clockwork Long Delay Tail Fuze (p 53)
 Type T-2 Mechanical Impact Tail Fuze (p 54)
 Type O-2, Mechanical Impact Tail Fuze (p 55)
 Tail Fuze for Hollow (Shaped) Charge Bombs (pp 55-6)
 Hydrostatic Tail Fuze, "Grand-Daddy" (p 57)

Mechanical Impact Nose Fuze "Orphan"
(pp 58-9)

Mechanical Anti-Disturbance Fuze, Manzolini
(pp 59-6)

5) Japanese Bomb Fuzes are subdivided into fuzes for Army Bombs and for Navy Bombs

Army Bomb Fuzes. These fuzes are not interchangeable with fuzes used in Navy bombs

Following Army fuzes are described in TM 9-1985-4 (Ref 28a):

Type 93 Instantaneous-Short Delay Nose Fuze A-2(a) (pp 123-24)

Type 12-Year Instantaneous Nose Fuze A-2(b) (pp 124-25)

Type 99 Instantaneous-Short Delay Nose Fuze A-2(c) (pp 126-27)

Type 1 Instantaneous Nose Fuze A-2(d) (pp 127-29)

Type 92 Nose Fuze for Large Bombs A-4(a) (p 129)

Nose Fuze for Type 3 Bomb A-6(a) (pp 129-31)

Nose Fuze for Type 3 Bomb A-6(b) (pp 131-32)

Nose Fuze for Type 2 Bomb A-7(a) (pp 132-33)

Type 4 Two-Second Delay Nose Fuze A-8(a) (pp 134-35)

Type 4 Two-Second Delay Nose Fuze for Large Bombs A-8(b) (pp 135-36)

Type 12-Year Tail Fuze B-1(a) (pp 137-38)

Type 1, 15-Second Delay Tail Fuze B-1(b) (pp 138-39)

Type 92 Tail Fuze for Large B-4(a) (p 140)
Tail Fuze B-5(a) (p 141)

Experimental 3.5-Second Tail Delay Fuze B-7(a) (pp 141-43)

Type 4 Five-Second Delay Tail Fuze B-8(a) (pp 143-44)

Type 1 Long-Delay Nose Fuze C-3(a) (pp 144-47)

Aerial Burst Nose Fuzes D-1(a) and D-1(b) (pp 147-49)

Type 1 Aerial-Burst Nose Fuze D-5(a) and Type 1 Combination Nose Fuze D-5(d) (pp 149-51)

Type 1 Anti-Withdrawal Tail Fuze E-1(a) (pp 151-53)

Experimental Remote Control Fuze (p 153)
Japanese Navy Bomb Fuzes. The following

types are described in Ref 28a, pp 154-89:

Nose Fuzes A-1(a), A-1(b) and A-1(c) (pp 154-66)

Type 97 Mk2 Nose Fuze Model 2 A-3(a) (pp 156-57)

Type 1 Nose Fuze Model 2 A-3(b) (pp 157-59)

Type 2 Nose Initiator A-3(c) (pp 159-60)

Type 97 Mk2 Nose Fuze Model 1 A-3(d) (pp 160-62)

Type 3 Nose Initiator A-3(e) (pp 162-63)

Type 2 No 50 Ordinary Bomb Model 1 Nose Fuze A-3(f) (pp 163-65)

Nose Fuze A-3(g) (pp 165-66)

Nose Fuze A-5(a) (pp 166-67)

Type 99 No 25 Ordinary Bomb Tail Fuze B-2(a) (pp 168-69)

Type 99 N8 Mk5 Bomb, Tail Fuze B-2(b) (pp 169-70)

Tail Fuzes Model 2 and Model 1 B-3(a) and B-3(b) (pp 170-72)

Tail Fuze B-5(b) (pp 172-73)

Tail Fuze B-5(c) (pp 174-75)

Type 97 Tail Initiator B-6(a) (pp 176-77)

Tail Fuze B-9(a) (pp 177-78)

Tail Fuze B-10(a) (p 179)

Type 99 Special Bomb, Tail Fuze C-1(a) (pp 179-80)

Type 99 Special Bomb, Nose Fuze C-2(a) (pp 181-82)

Aerial Burst Tail Fuzes D-2(a), D-2(b) and D-2(c) (pp 182-85)

Aerial Burst Nose Fuze D-3(a) (pp 186-87)

Nose Fuze for Type O Parachute, Model 1, D-4(a) (pp 187-88)

Type 3 Electric Firing Device (pp 188-89)

6) Russian Bomb Fuzes. No information is available

Section 6, Part D

Bomb Explosive Train Components

Under this title are included bomb adapter-booster, auxiliary boosters, primer-detonator, delay elements, bursters and igniters

a) Bomb Adapter-Boosters

The following information may be added to the brief description given in Ref 43, p A102-L:

An adapter-booster is a bushing which is threaded on the outside for assembly

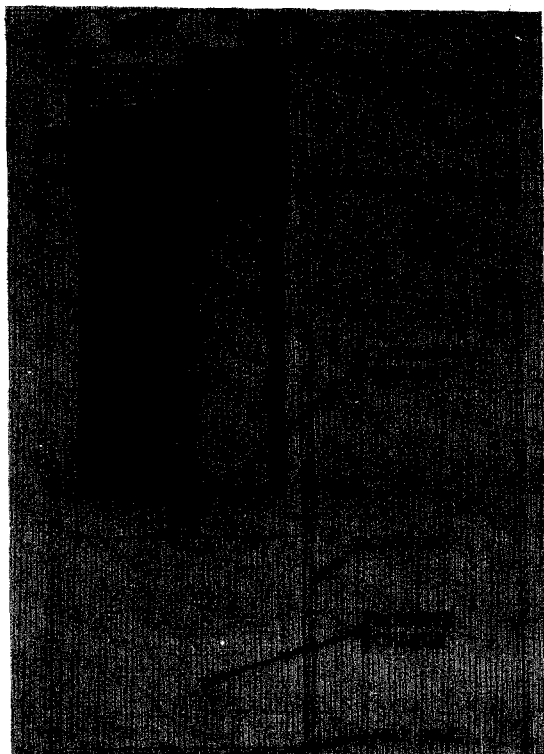

Fig 5-1 BOMB TAIL ADAPTER-BOOSTER,
M102A1

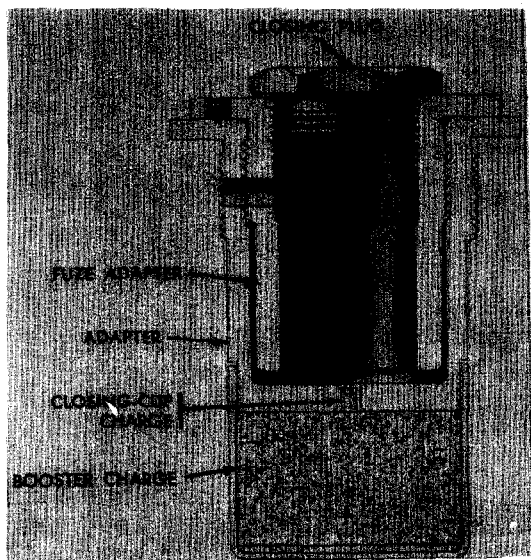

Fig 5-2 BOMB TAIL ADAPTER-BOOSTER,
M115A1

to the bomb body and on the inside for assembly to the fuze. Adapter-boosters, normally assembled to high-explosive and chemical bombs, are drilled for the insertion of lock pins which prevent their removal when antiwithdrawal fuzes are to be assembled to the bomb. Since most general purpose bombs are adapted to accommodate large diameter nose fuzes, a nose adapter-booster is issued separately to adapt these bombs for use with small diameter fuzes. Low-drag and new series GP bombs, developed for both mechanical and electrical fuzing, require nose and tail adapter-boosters when mechanical fuzes are installed

Bomb Tail Adapter Booster, M102A2, shown in Fig 5-1, provides a tail-fuze seat for certain GP and SAP bombs. It requires an adapter-booster lock pin to prevent its removal after an antiwithdrawal fuze is inserted in the bomb. The adapter has an ID of 1.5-inches, its cavity is 2.86-in deep, and overall length 4.64-in. Its closing-cup assembly contains 1.53 grains of Tetryl and its booster chge is Tetryl (884.0 grains) (Ref 51a, pp 5-1 & 5-2)

Bomb Tail Adapter-Booster, M115A1, shown in Fig 5-2, provides a tail fuze seat for some GP bombs. It has an inner sleeve with ID of 1.5-inches to accommodate Army-designed fuzes and, if the sleeve is removed, the adapter-booster will accommodate Navy fuzes, which have ID of 2.0-in. The cavity is 2.68-in deep, the wt of Tetryl chge in closing-cup assembly is 1.53 grains and the wt of Tetryl chge in booster 1853 grains. Overall length of adapter 4.45-inches (Ref 51a, p 5-3)

Bomb Tail Adapter-Booster, M117, shown in Fig 5-3, adapts GP bombs with large fuze seats to accommodate small fragmentation type fuzes. Its overall length is 6.35-in, diam ca 2-in and wt of Tetryl chge for booster 0.29-lb (Ref 51a, p 5-4)

Bomb Adapter-Booster, M126A1 (T45E1), shown in Fig 5-4, permits the use of a 2-inch thread for MT or VT fuzes in the new-series and the low-drag GP bombs, including Snakeye I. Its overall length is 6.83-inches, diam ca 2-in and the wt of Tetryl booster

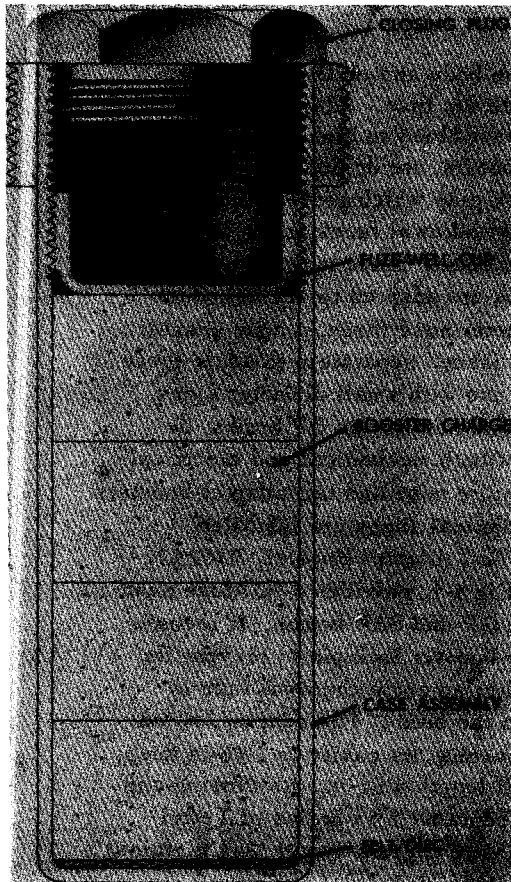

Fig 5-3 BOMB TAIL ADAPTER-BOOSTER,
M117

chge 0.43-lb (Ref 51a, p 5-5)

Bomb Adapter-Booster, T46E4, shown in Fig 5-5, permits the use of a 1.5-inch thread size MT fuze in new-series, low-drag GP bombs, and MC gas bombs. Overall length 8.70-inches, diam ca 2-in and wt of Tetryl booster chge 0.26-lb (Ref 51a, p 5-6)

Bomb Adapter-Booster, T59, shown in Fig 5-6 of Ref 51a (not reproduced here), is used to ignite the detonating cord which opens leaflet bomb M139. Adapter is metallic cylinder 2.89-inches in diam, 6.03-in long, which contains Tetryl booster charge (Ref 51a, p 5-9)

Section 6, Part D

b) Bomb Auxiliary Boosters

Auxiliary boosters are cylindrical charges of Tetryl which are either contained in a chipboard or metallic cup or cast within

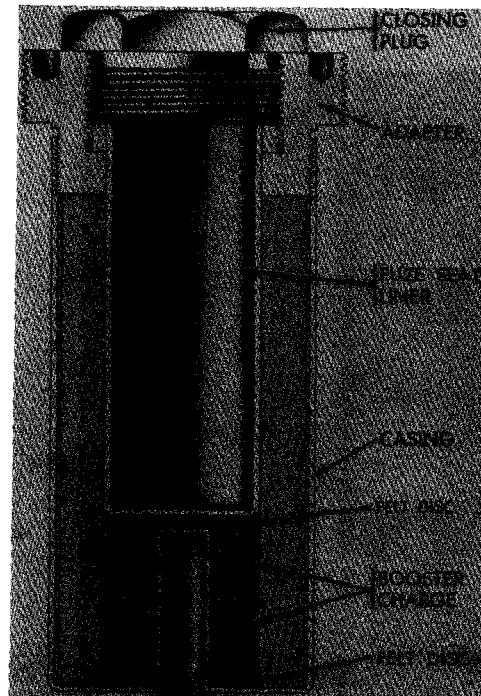

Fig 5-4 BOMB ADAPTER-BOOSTER,
M126A1 (T45E1)

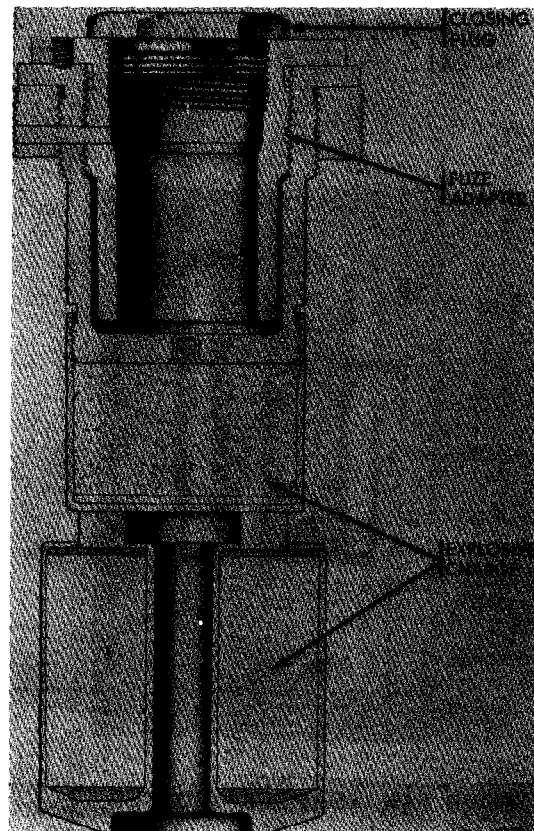

Fig 5-5 BOMB ADAPTER-BOOSTER,
T46E4

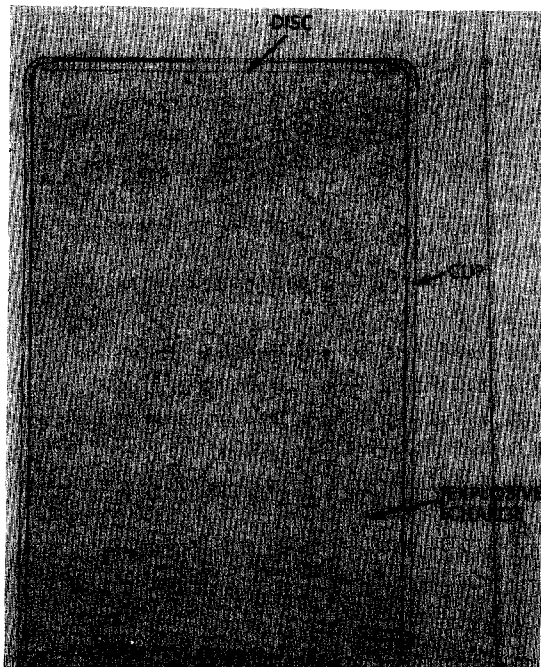

Fig 5-6 BOMB AUXILIARY BOOSTER,
Mk1, Mod0

the explosive chge adjacent to the fuze-seat liner or the adapter-booster, or both. Auxiliary boosters serve to relay and amplify detonating wave of the fuze to insure the explosion of the main chge. Some of the large GP bombs require two auxiliary boosters

Bomb Auxiliary Booster, Mk1Mod0, shown in Fig 5-6, is a standard item shipped in either the nose or the tail-fuze seat liner (or both) of some types of GP and Frag bombs weighing over 100-lb. It consists of a thin metallic cylinder 1.85-inches in diam and 2.98-inches high. It is filled with 180 grams of Tetryl and closed at the top with a disc (Ref 51a, p 5-8)

Bomb Auxiliary Booster, Mk4Mod0, shown in Fig 5-7, consists of a chipboard tubing, 1.6-inches in diam and 3.0-in long, filled with 63.0 g of Tetryl, and closed at both ends by metal cups cemented to the tube. White paper is glued to the outside of the tube and covered with a transparent lacquer of shellac. This auxiliary booster is used in the nose-fuze seat liners of AN-GP bombs using nose fuze Mk219 (Ref 51a, p 5-9)

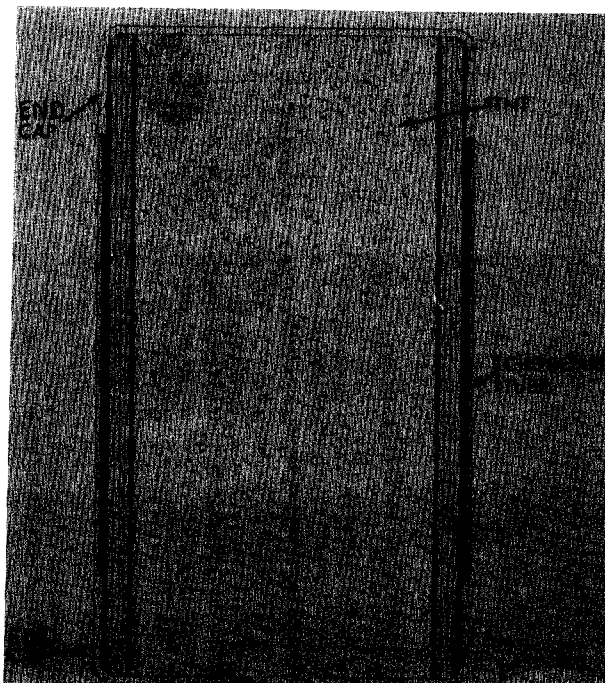

Fig 5-7 BOMB AUXILIARY BOOSTER,
Mk4, Mod0

Section 6, Part D

c) Bomb Primer-Detonators

A bomb primer-detonator is an interchangeable unit (composed of a primer delay element and a detonator) which is designed to provide delay in the action of older models of tail fuzes. Primer-detonators of various time delays are available, with the exact delay time of each painted on the detonator head (Ref 51 a, p 5-9)



Fig 5-8 BOMB PRIMER-DETONATOR,
M14

Primer-Detonator, M14, shown in Fig 5-8, is available with delays 0.0, 0.01, 0.025, 0.10 and 0.24-second. Diameter of body is 1.25-inches, length of assembly 1.77-in, its wt 0.5-lb, and wt of explosive chge 0.095 grams (Ref 51a, p 5-10)

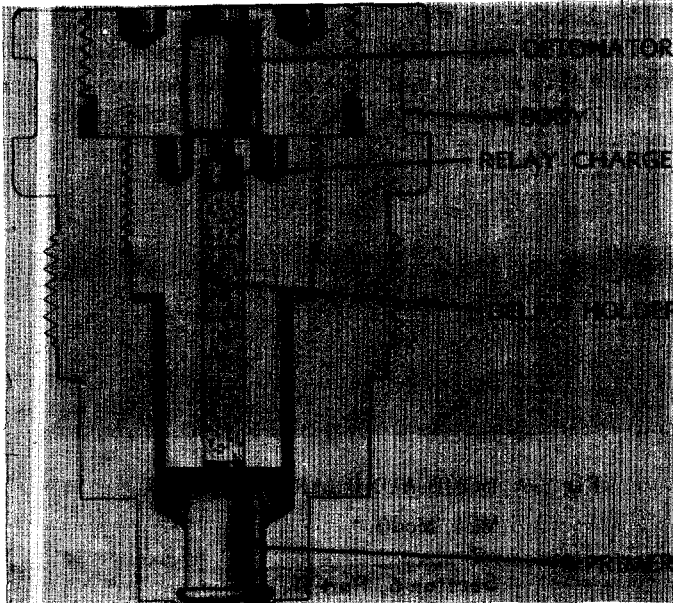

Fig 5-9 BOMB PRIMER-DETONATOR, M16

Primer-Detonators, M16 & M16A1, shown in Fig 5-9, have bodies 1.25-inches in diam, 1.78-in long, and weigh 0.5-lb together with 1.4 grams of expl chge. They are available with delays of 4 to 5 and 8 to 15-seconds. The M16A1 has a high shoulder, while M16 does not have one. The shoulder is added so that upon severe impact no malfunction takes place. Both primer-detonators are used in tail fuzes M112, M113 & M114. They are provided with a groove around the head as distinguished from the knurled head of the M14 primer-detonator. The 4 to 5-sec delay type is used against ship targets, while the 8 to 15-sec delay type against shore targets (Ref 51a, pp 5-11 & 5-12)

Section 6, Part D

d) Bomb Delay Elements

Definition of term "delay element" is given in Ref 48, p D52-L and compositions of "delay charges" are given in Ref 48, p D50-L

The following "bomb delay elements" are described in Ref 51a, p 5-13:

Delay Element, M9 is a cylinder 0.75-inches in diam, 0.875-in long, filled with 0.14-lb of a delay composition. It is available in 5 firing delay times (0.01, 0.025, 0.05, 0.1 & 0.25-secs) and one non-delay (0.0-sec) (Ref 51a, p 5-13)



Fig 5-10 BOMB DELAY ELEMENTS, M9, T5E3 & T6E4

Delay Elements, T5E3 & T6E4 have an oval-shaped body, 0.49-inches wide, 0.97-in high and 1.55-in long, filled with a delay compn (7.64 grams for T5E3 and 7.25 g for T6E4). These delay elements provide fuze M906 with impact firing delays of 5.0 to 12.5-seconds (Ref 51a, p 5-13)

Section 6, Part D

e) Bomb Bursters

Definition of term "burster" is given in Ref 44, p B364-L and in Ref 51a, p 5-13. Explosive charges used in bursters include BkPdr, BkPdr + Mg powd (coated with oil), TNT, Tetryl or Composition B. When the burster is installed in the bomb, it fits into either the burster well or the ignition cavity

Following types of bomb bursters are described in Ref 51a:

Bomb Burster, AN-M12, designed for use in incendiary bomb AN-M47A3, consists of a cylindrical plastic or Al body, 1.3-inches in diam, and 37.88-in long filled with 435 grams of an expl chge consisting of an oil-coated mixt of BkPdr & Mg powder. One end of the cylinder is closed by a plain metal or plastic plug, while the other end is closed with a plug assembly consisting of a thin-walled metal cup (filled with primary mixture), inserted in a steel cup holder (Compare with the left-hand side plug of Fig 5-11). The end of the cup holder is hexagonal and forms a shoulder by which the burster is held in position in the bomb (Ref 51a, p 5-14)

Bomb Burster, AN-M13, designed for use (in conjunction with igniter AN-M9) in incendiary bomb AN-M47A4, consists of a plastic tube 0.45-inches in diam, 36.0-in long, provided at each end with a soft brass cup. It is filled with ca 65 g of TNT and has a Tetryl pellet at each end (Ref 51a, p 5-15)

Bomb Burster, AN-M18, shown in Fig 5-11, consists of a plastic tube 1.13-inch in diam and 37.94-in long, filled with 250 g of BkPdr, a spacer and sand. One end of the tube is closed by a metal or plastic plug, while the other end by a plug assembly consisting of a thin-walled metal cup (contg a primer chge) inserted in a metal cup holder. The end of the cup holder is hexagonal and forms a shoulder by which the burster is held in position in the bomb. Burster M18 is used in smoke bombs AN-M43A3 and AN-M47A4 when they are filled with WP (Ref 51a, p 5-16)

Bomb Burster, AN-M20, designed for use in smoke bombs AN-M47A3 & AN-M47A4 when they are filled with PWP, consists of a paper tube 1.13-inches in diam & 37.94-in long filled with 242 g of Tetryl pellets, without addition of sand as in M18. One end of the tube is closed with a metal or plastic plug with a felt disc (serving as a spacer), placed between the plug and Tetryl pellets; the other end is closed with the same type of plug assembly as shown on left-hand side of Fig 5-11. Burster M20 is used in smoke bombs AN-M47A3 and AN-M47A4 when the bomb is filled with PWP (Ref 51a, p 5-17)

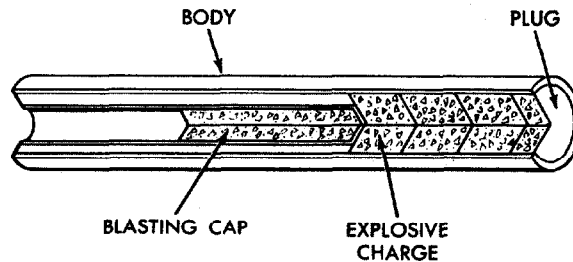

Fig 5-12 BOMB BURSTER, C8R1

Bomb Burster, C8R1, shown in Fig 5-12, consists of a tubular fiber body, 0.47-inches in diam and 3.07-in long, partly filled with 2.5 g of Tetryl and provided with a nonelectric blasting cap at the open end of the tube. The end of the tube contg Tetryl is closed by a fiber plug. This burster is a component of igniters M15 & M16 (Ref 51a, p 5-18)

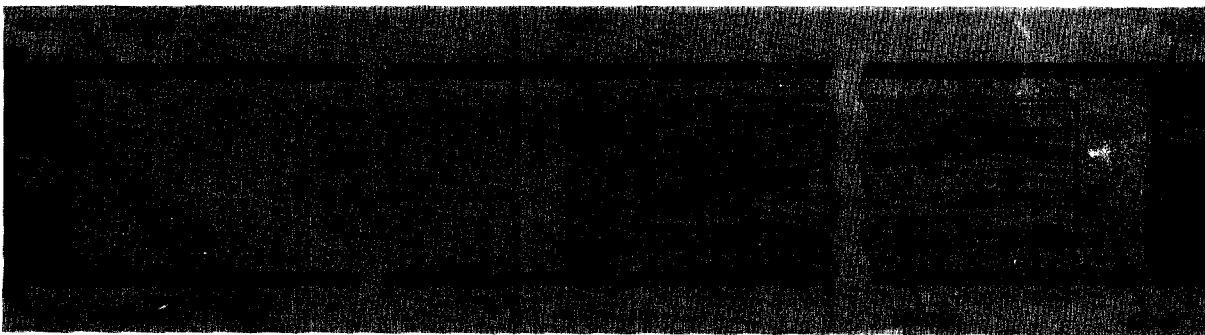

Fig 5-11 BOMB BURSTER, AN-M18

Bomb Burster M31 consists of a cylindrical fiber body 1.44-inches in diam & 7.0-in long filled with 250 g of Tetryl. One end of the body is closed by a plastic cap, while the other end by a paper disc. This burster is an integral part of nonpersistent gas bombs M125 & M125A1, and is installed in the bombs during their manuf (Ref 51a, p 5-19)

Bomb Burster, M32, consists of an impregnated moisture-vaporproof fiber cylinder, 3.42-inches in diam and 32.5-in long filled with 15.0 g of Comp B. Both ends are closed with metallic caps with shock-absorbent material cemented to them. This burster is designed to burst the body and disperse the filler of 750-lb nonpersistent gas bomb MC-1 (Ref 51a, p 5-20)

Section 6, Part D

f) Bomb Igniters

A bomb igniter is an item designed for setting fire to the filler of incendiary and fire bombs

Following bomb igniters are described in Ref 51a:

Bomb Igniter, AN-M9, shown in Fig 5-13, consists of two concentric steel tubes joined at both ends to form an annular space which is filled with 1.6-lb of WP for land bombing or Na for water bombing. Outside diam is 1.25-inches, inside diam 0.88-in and overall length 38.34-in. The inner tube, which is ca 1.25-in shorter than the outer tube, contains a small coil spring for snubbing inserted bomb burster M13 (Ref 51a, p 5-21)

Bomb Igniter, M15 is designed to be attached to a jettison-type aircraft fuel tank to adapt it for use as a fire bomb. It consists of an igniter body, called grenade (steel cylinder 2.38-inches in diam and 4.50-in long & filled with 0.9-lb WP or 0.5-lb Na), C8R1 burster (placed inside the well located in the center of filler of the igniter body), adapter, fuze M157, arming wire and arming vane. Overall length of assembly is 7.7-inches. This igniter resembles in appearance the igniter AN-N16, shown in Fig 5-14

When a fuel tank assembled with igniter M15, is released from an aircraft, the arming wire of igniter is withdrawn from the fuze and the arming vane rotating in an airstream, arms the fuze. On impact with a target, the fuze ignites, explodes the burster and breaks igniter body (grenade), allowing WP or Na filler to ignite the fuel released from broken jettisoned tank, thus spreading the fire at the target (Ref 51a, pp 5-22 & 5-23)

Bomb Igniter, AN-M16, shown in Fig 5-14, consists of a body, called grenade (of the same size as M15 igniter and filled with 0.95-lb WP or 0.5-lb Na), C8R1 burster, adapter, impact fuze M157, arming wire and arming vane. A gasoline tank cap assembly attached to the igniter body is used when assembling the igniter to the bomb

When a fire bomb assembled with this igniter is dropped, the arming wire is pulled and the fuze arms after about 100-ft of air travel. On impact the fuze ignites and explodes burster charge and the rest is the same as described under igniter M15 (Ref 51a, p 5-24)

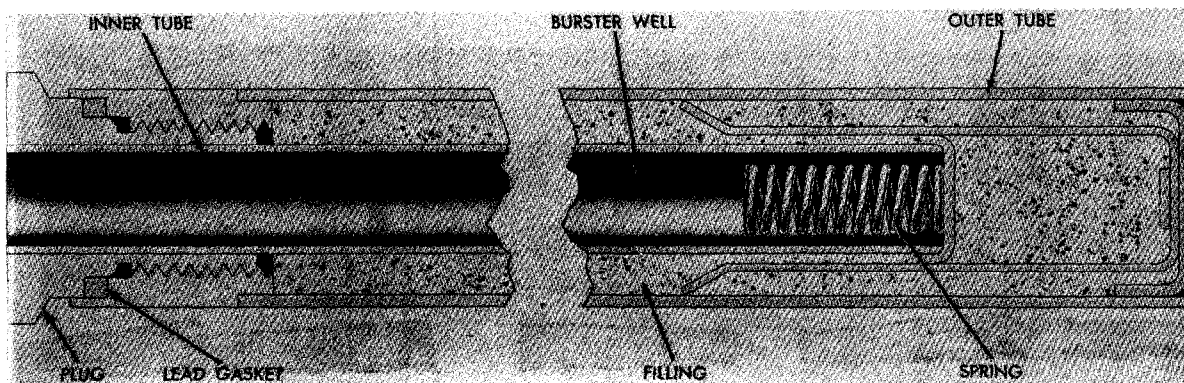

Fig 5-13 BOMB IGNITER, AN-M9

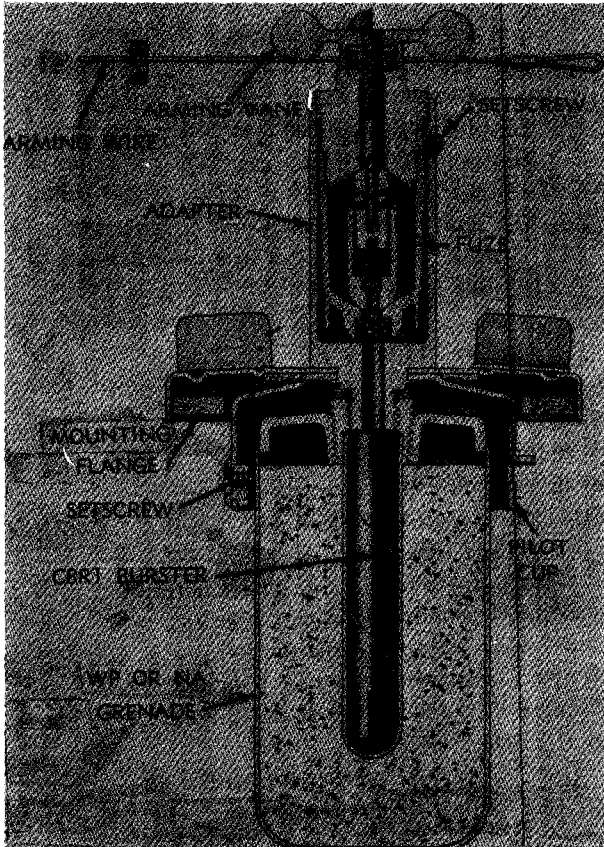

Fig 5-14 BOMB IGNITER, AN-M16

Bomb Igniter, AN-M23A1, shown in Fig 5-15, is cylindrical in shape, rounded at one end and externally threaded at the other. Diam of body is 3.85-in and length of assembly 3.6-in. A fuze adapter attached at the rounded end of the igniter is threaded internally to receive bomb fuze AN-M173A1. The igniter body is filled thru the opening at the flat end of igniter body with 1.25-lb of WP and then the opening is closed with the filler plug. Igniter AN-M23A1, as well as its earlier model M23, is designed for use with fire bombs M116A1 or M116A2

When the fire bomb strikes the target, the fuze functions, exploding the booster and this bursts the igniter, thus scattering WP, which ignites the moment it comes in contact with air (Ref 51a, p 5-25)

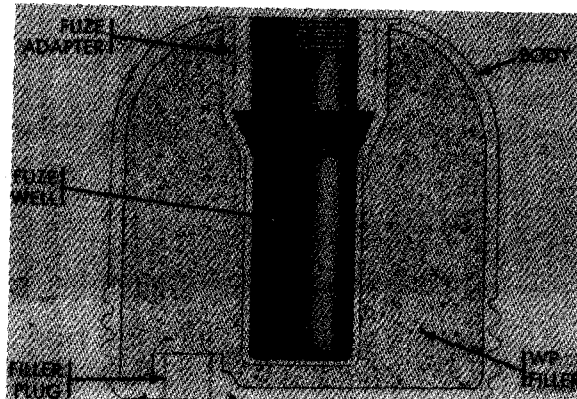

Fig 5-15 BOMB IGNITER, AN-M23A1

Section 6, Part E

Bomb Signal and Spotting Components

a) Bomb Signal Cartridges

A signal cartridge used for spotting purposes during practice drills, consists of a small charge of pyrotechnic or inert material which produces a visible signal when expelled from its container by the action of a fuze

Following signal cartridges are described in Ref 51a:

Practice Bomb Signal, MkMod3 (or Mod4), shown in Fig 5-16, is an Al cartridge 0.85-inches in diam and 6.0-in long, resembling an elongated 10-gauge shell, which contains at its base a commercial primer and an expelling chge of smokeless proplnt. A pyrotechnic marker load (stabilized red phosphorus for Mk4Mod3) or inert marker load (Zn oxide for Mk4Mod4) is separated from expelling chge by a disc and cardboard gun wad. The front end of the cartridge is closed by felt gun wad which is cemented to the cover

When the practice bomb in which the signal is installed strikes a target, impact causes the firing pin in the nose of the bomb to impinge upon the primer of the signal cartridge. The flame of primer ignites the expelling chge, forcing the marker load out thru an opening in the bomb. The resulting flash and puff of white smoke permit observation of bombing accuracy (Ref 51a, pp 5-26 & 5-27)

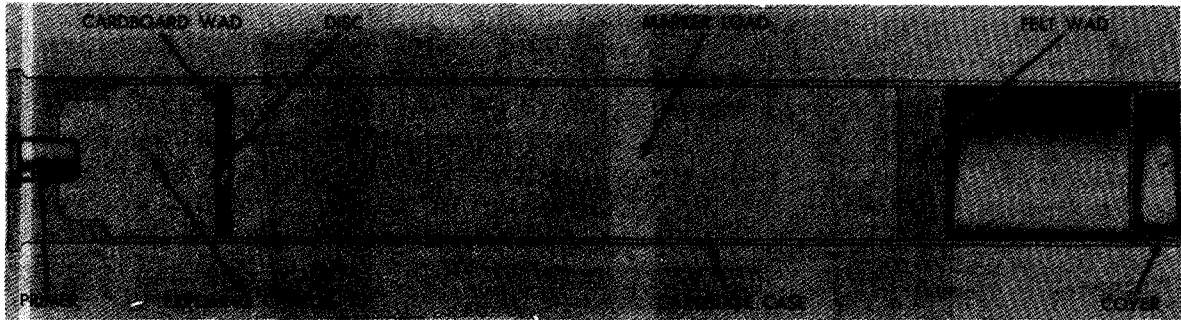

Fig 5-16 PRACTICE BOMB SIGNALS,
Mk4Mods3 & 4

Practice Bomb Signal, Mk5Mod0 is a cylindrical plastic container, 0.93-inch in diam, 1.74-in long and weighs ca 15 g when filled with 10 g of fluorescein dye. The dye is brick-red when dry but turns bright-green when dissolved in water. The container is closed with a thin plastic cap easily collapsible under pressure. This signal is used in dive-bombing daylight practice over water.

When signal hits water, the plastic cover collapses, thus allowing water to force the dye out thru the tail of the bomb. The resulting bright-green spot of dissolved dye on the surface of water permits one to locate the place where the bomb hit the water (Ref 51a, p 5-28)

Practice Bomb Signal, Mk6Mod0, shown in Fig 5-17 with fuze, consists of a thin-walled, steel cylinder filled with 2.0-lb of BkPdr, and fitted with inert fuze AN-Mk247Mod0 & a blank .38-caliber cartridge used as a detonator. The cartridge is located some distance from the axis of cylinder. Diam of cylinder is 3-inches, its length 8-in and the wt of assembled signal 3.7-lb

Upon release of the bomb from the aircraft, the arming wire is withdrawn, permitting the fuze arming vane to rotate and arm the signal. When target is hit, the firing pin in the fuze overcomes a creep spring and impinges upon the primer of the blank cartridge, which, in turn, ignites

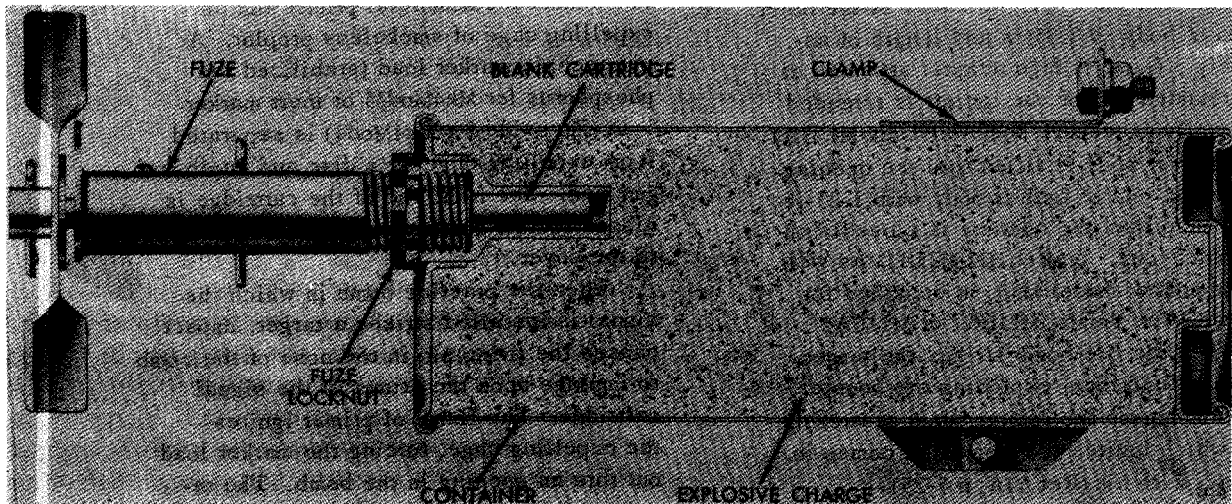

Fig 5-17 PRACTICE BOMB SIGNAL, Mk6Mod0 (With Fuze)

the BkPdr chge in the cylinder. The resulting expln produces a flash of light and a large puff of gray smoke (Ref 51a, p 5-29)

Practice Bomb Signal, Mk7Mod0 consists of a thin-walled steel cylinder filled with 1.0-lb of BkPdr and fitted with inert fuze AN-M247Mod0 and a blank .38-cal cartridge used as a detonator. The cartridge is located at the axis of cylinder. Diam of cylinder is 2.0-inches, its length ca 10-in and wt of assembled signal 2.5-lb. It resembles in appearance signal Mk6Mod0 (shown in Fig 5-17) and it functions in exactly the same manner (Ref 51a, p 5-30)

Section 6, Part E

b) Bomb Spotting Charges

Spotting charges function in the same manner and for the same purposes as the signal cartridges, but the amounts of filler carried by spotting charges are larger, such as ca 10-lb. One example is given below

Spotting Charge, M39A1, shown in Fig 5-18, consists of a cylindrical terne-plate casing filled with 10.2-lb of 80/20-BkPdr/Al (flaked) mixture and with a smaller amt of spotting chge, located at the rear of the cartridge which is closed with a felt pad. Diam of cartridge is 3.45-inches and its length 32.05-in. The front of cartridge is closed with a funnel-shaped cover, which carries a tube extending thru the center of the tube to the partition separating expl filler from spotting chge (Ref 51a, p 5-31)

Section 6, Part E

c) Bomb Spotting Charge Igniters

Spotting charge igniters act as relays between the fuze and spotting charge. One example is given below

Spotting Charge Igniter, M32, authorized for use with 250-lb practice bomb M124, consists of ca 58-inches of reinforced plastic-covered detonating cord with a relay assembly crimped to each end. The detonating cord contains PETN and the relay assembly contains a charge of ca 6 grains of PETN in an Al sleeve with flange. The flange holds the end of the igniter in place in the fuze-well of the bomb (Ref 51a, p 5-32)

Section 6, Part F

Bomb Nonexplosive Components

(Other than Clusters)

Besides clusters, which are described in Section 6, Part B, the following items are considered non-explosive components of bombs:

a) **Bomb Arming-Wire Assemblies**, shown in Fig 5-19, usually consist of either one or two strands (branches) of wire attached to a swivel loop. They are used to lock the fuze-arming mechanism in an unarmed position. Fahnestock (safety) clips are attached to the ends of the wires after installation of the fuzes in the bomb. This prevents accidental withdrawal of the the wires while the aircraft is in flight. If the bomb is to be released from the rack

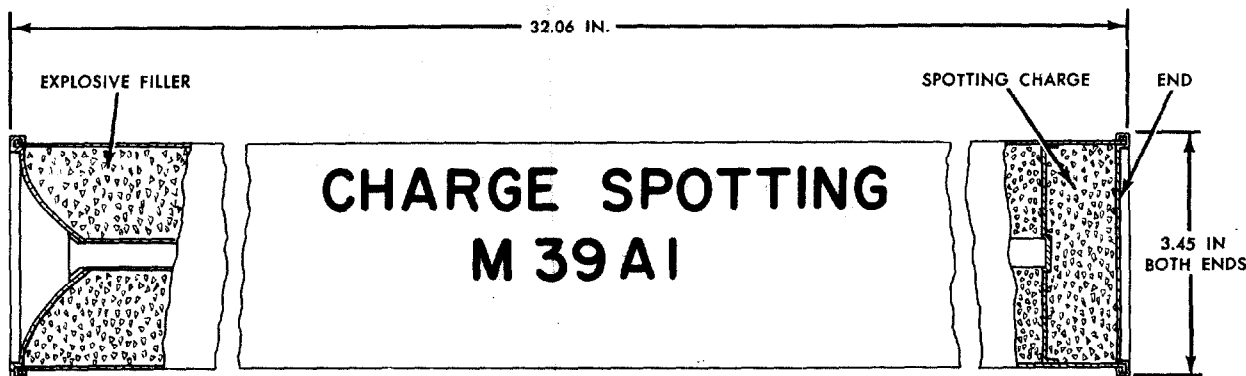

Fig 5-18 BOMB SPOTTING CHARGE, M39A1

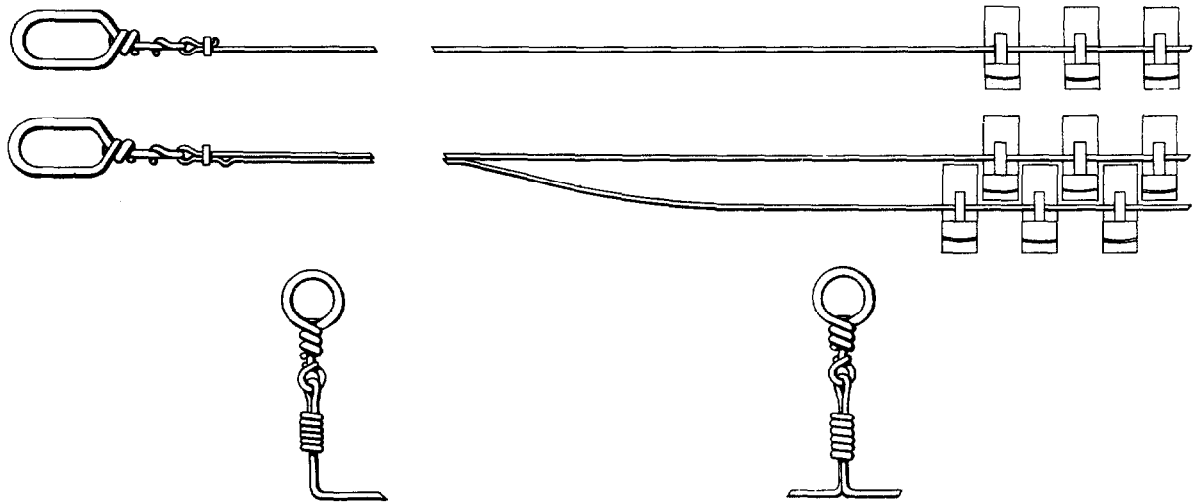

Fig 5-19 BOMB ARMING-WIRE ASSEMBLIES
(Various Types)

"armed"; the wire is pulled from the fuze head, which allows the fuze vanes to rotate, arming the fuze. If the bomb is to be released "safe", the arming wire is not separated from the fuze head. Table 5-30 given on pp 5-33 to 5-35 of Ref 51a lists arming-wire assemblies used by US Armed Forces

Section 6, Part F

b) Bomb Arming-Vane Assemblies

Most fuzes now in use are armed by the action of an arming vane, such as shown in Fig 5-20. This action is similar to the action of a propeller, except that the vane is driven not by a motor but by the airstream during the bomb flight toward the target.

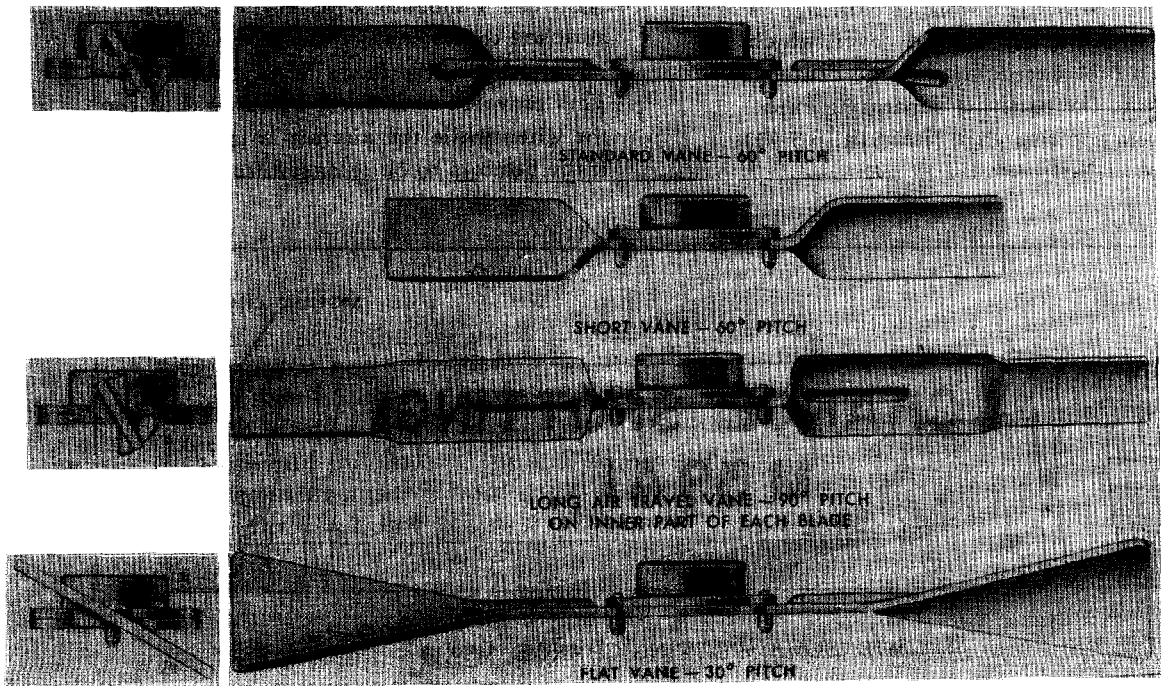

Fig 5-20 BOMB ARMING-VANE ASSEMBLIES
(Various Types)

The arming vane may drive a gear train which, after a definite interval, removes safety blocks or aligns the detonator with the next element in the explosive train. Standard arming vanes have blade pitches of 30°, 60° or 90°, but there are also "special" vane assemblies with different blade pitches (Ref 51a, p 5-38)

Section 6, Part F

c) Bomb Arming-Delay Mechanism

In certain cases when a delay of the arming of the bomb is required, a device known as an arming-delay mechanism M1 or M1A1 is attached to the fuze. Upon completion of the preset time, the arming delay releases itself and is forced away from the fuze by the spring of the vane lock which is ejected, thus starting the arming of the fuze. The arming delay consists mainly of a wind vane, a reduction gear train, a setting dial and a lock which attaches it to the ring or bracket of the fuze

A more complete description of the device is given in Ref 51a, pp 5-39 to 5-41. The photographic view is given in Fig 5-32, p 5-39 and its installation with proximity (VT) fuze M188 is shown in Fig 5-33, p 5-40. These Figs are not reproduced here

Section 6, Part F

d) Bomb Flight Stabilizers

Stabilization of bomb flights is usually achieved by fins, but if a slow descent is desirable parachutes or parasheets are used. Fig on p B227-L of Ref 44 gives an idea about methods of stabilizing bombs in flight

Following is a brief description of *fin assemblies*:

There are two basic types: the *box fin* and the *conical fin* and two varieties of each of these types: the "retarding fin" and the "fin for chemical clusters". Fins are usually manufd from sheet metal, but for bombs of recent design used at high-altitude and high-speed flying fins are made of steel

The types of fin assemblies used by US Armed Forces are listed in Table 5-31, pp 5-43 & 5-44 of Ref 51a

We are giving here four figs showing different types of fin assemblies. See Figs 5-21 to 5-24

Section 6, Part F

e) Drag Plates and Spoiler Rings

A *drag plate*, used for slowing down bomb flights, is an 8-inch square sheet metal with four protruding tabs, each contg a tapped hole which accommodates a screw. When the plate is placed over the rear end

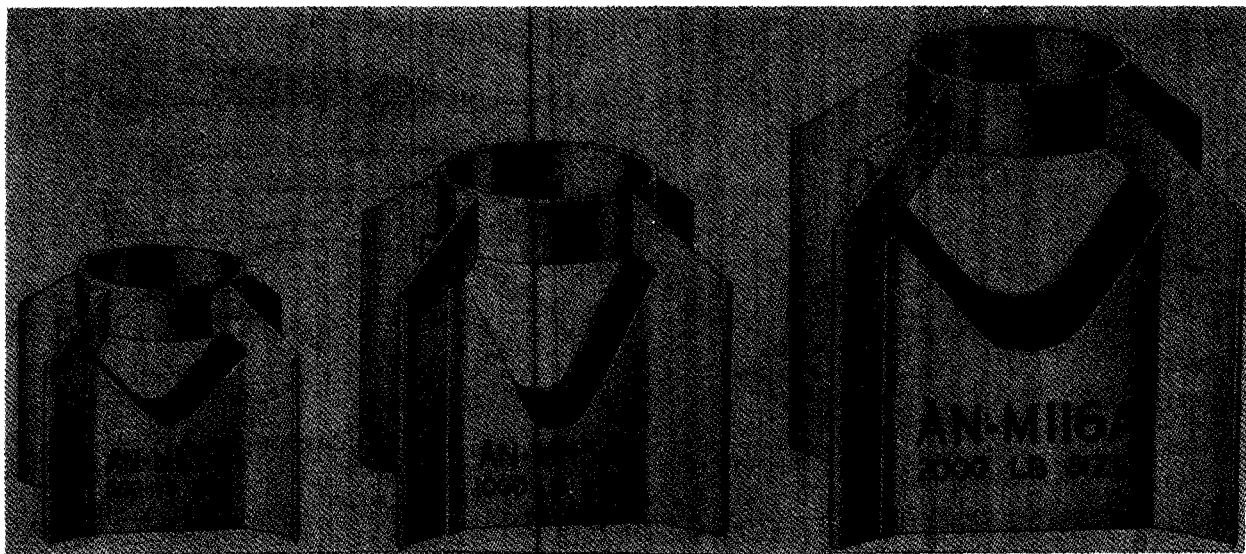

Fig 5-21 BOMB FIN ASSEMBLIES (Box Type)

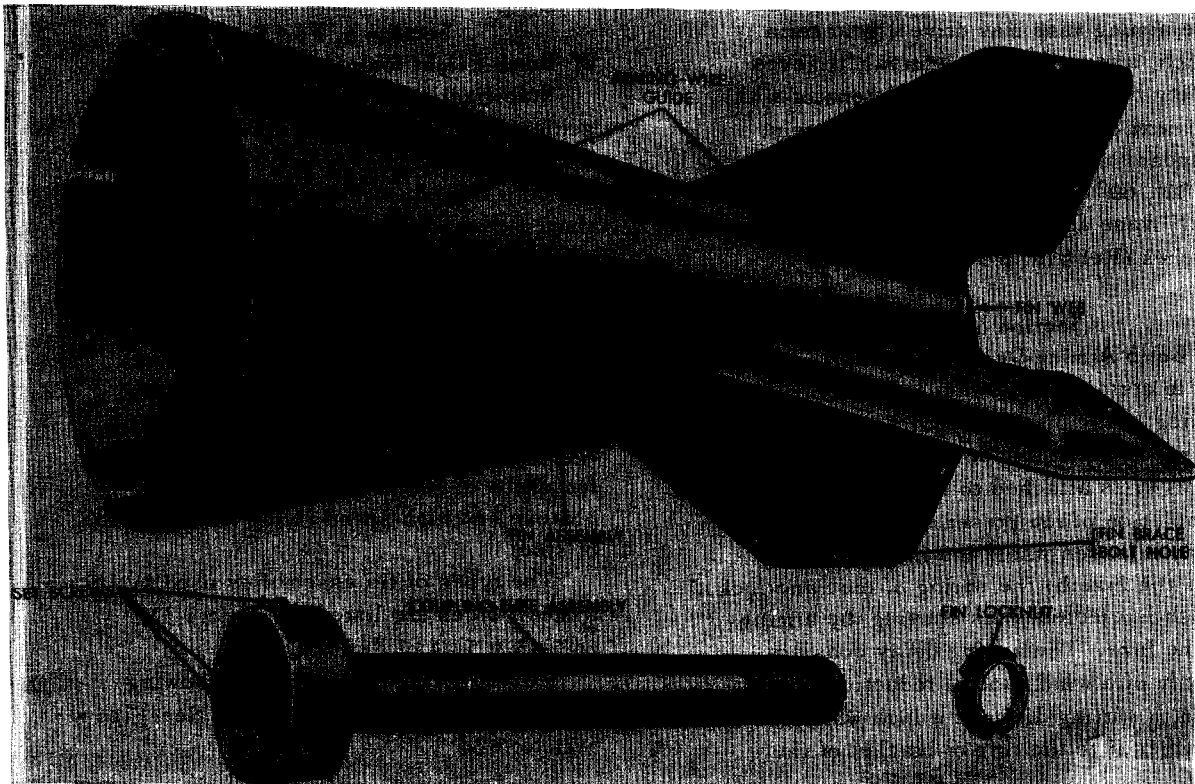

Fig 5-22 BOMB FIN ASSEMBLIES (Conical Type)

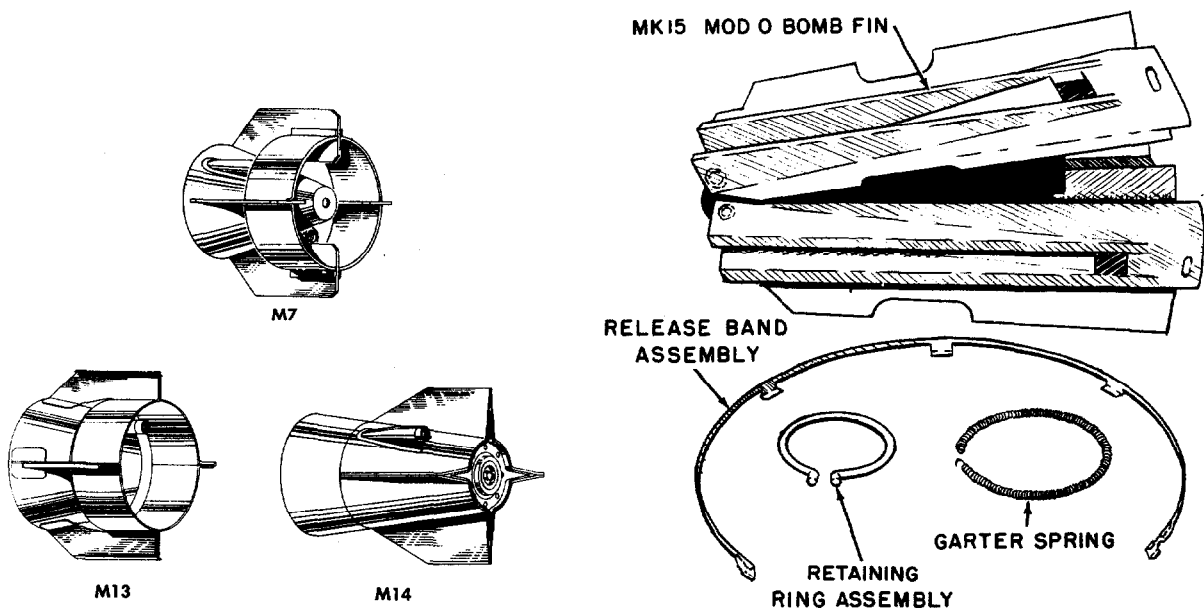

Fig 5-23 FIN ASSEMBLIES FOR CHEMICAL CLUSTERS

Fig 5-24 BOMB FIN ASSEMBLY (Retarding Type)

of the fin assembly, each tab aligns with a hole in the fin box, and is secured with four screws

A *Spoiler ring*, used to disturb the air flow causing a loss of lift and increase of drag, is a circular piece of sheet metal (7.875-inches in diam) contg one central hole large enough to accommodate the threaded end of a nose fuze and one small hole thru which the arming wire is passed (Ref 51a, p 5-49)

Section 6, Part F

f) Bomb Initiators

Two types, FMU-7/B and FMU-7AB, similar in construction and function, are described in Ref 51a, p 5-50 and are shown here in Fig 5-25. They are used in conjunction with FMU-7 series fuzes and cable assemblies in the BLU series fire bombs

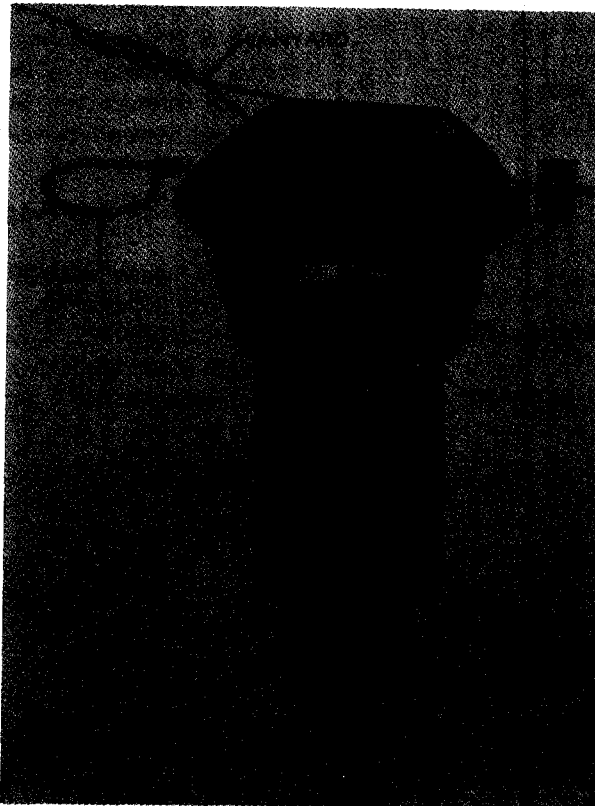

Fig 5-25 BOMB INITIATORS,
FMU-7/B & FMU-7A/B

When a bomb is released from an aircraft, the cap on the top of the initiator is withdrawn by a lanyard attached to a shackle. This results in actuation of a thermal battery, which after 0.5 to 0.9-sec delay, produces an electrical pulse which is transmitted thru the cable assembly to a fuze FMU-7 series

Cable Assemblies FMU-7B and FMU-7A/B are electrical cables 0.19-inches in diam and 76-in long used to interconnect the FMU-7 series fuzes with the FMU-7 series initiators on BLU series fire bombs (Ref 51a, p 5-51)

Section 7, Part A

REFERENCES

(Books, Pamphlets and Technical Manuals on Detonators, Primers, Fuses, Fuzes and Igniters)

- Ref 1) G.B. Taylor & W.C. Cope, "Initial Priming Substances for High Explosives"; USBurMinesTechPaper **162** (1917)
 1a) Marshall **1** (1917), 38-9 (Shell fuzes); 160 (Detonators); Ibid **2** (1917), 521 (Percussion primer); 523 (Detonator); 540-44 (Fuse detonating) 1b) Barnett (1919), 153-56 (Detonators); 156-59 (Fuses detonating and safety)
 2) Vennin, Burlot & Lécorché (1932), 563-64 (Méches d'allumage); 564-68 (Amorçages par choc ou friction); 568-70 (Détonateurs)
 2a) N.N. Ushakov & K.K. Andreev, "Initsiruyushchiye Vzryvchatyiye Veshchestva" (Initiating Explosive Substances), KhimJekh-Izdat, Moscow (1932)
 3) Stettbacher (1933), 324-40 (Zündsprengstoffe); 340-44 (Zündsätze und Zündhütchen); 344-55 (Sprengkapseln); 356-60 (Zündschnüre);
 3a) N.A. Tolch & J.E. Tiffany, "Some Physical Properties and Characteristics of Fuses"; USBurMines Report of Investigation **RI3235** (1934) & CA **28**, 3904 (1934) 3b) P.P. Karpov, "Kapsyl'noye Delo"; GosKhimIzdat, Moscow (1934) (Description of primer and detonator caps, including their testing)
 4) Pepin Lehalleur (1935), 364-66 (Composition d'amorçage); 366-69 (Détonateurs pour mines); 369-71 (Détonateurs électriques);

- 373-74 (Detonateurs à action chimique)
- 5) Beyling & Drekopf (1936), 150-59 (Zündung der Sprengschüsse; Sprengkapseln); 159-61 (Detonierende Zündschnüre); 161-71 (Zündschnurzündung); 171-246 (Elektrische Zündung)
- 6) Hayes (1938), 572-78 (Propellent primers-percussion, friction, electric, combination and igniting); 578 (Fuze primers); 579-97 (Projectile fuzes); 624-25 (Historical on primers in military rifles); 658-60 (Small arms primers); 660 (Berdan primer)
- 7) E. Piantanida, "Chimica degli Esplosivi"; Tipo-Litografia della R Accademia Navale, Livorno (1940), 189-202 (Gli alti esplosivi da innesca) (High initiating expls)
- 7a) R.L. Grant & A.B. Coates, "Safe Opening and Construction of Detonators", USBurMine **RI3594**(1941)
- 8) W.R. Tomlinson, Jr, "Compilation of Data on the Composition of Foreign Primers and Detonators", PATR **1343**(1943) (Results of analyses conducted at PicArsn labs on compns of primers and detonators used during WWII by the Germans, Russians, Italians and Japanese are tabulated and compared with corresponding primer and detonator compns used in the US at that time) (See also PATR's listed here as Refs 9a & 12a) 8a) Meyer (1943), 289 (Initiation by ignition); 291 (Initiation by percussion); 294 (Initiation by detonation and detonators); 318 (Igniter pad in separate-loading ammunition); 331 (Safety fuse); 332 (Squibs); 332 (Blasting caps); 334 (Blasting machine); 335 (Cordeau Bickford); 336 (Primacord); 337-40 (Primers for propellant charges); 340-43 (Electric primers); 343 (Igniting primers); 343-65 (Fuzes, boosters and adapters)
- 9) Davis (1943), 400-53 (Primary expls, detonators and primers); 453-54 (Friction primers); 454-58 (Percussion primers) 9a) D. Hart, "Compilation of Data on the Composition of Foreign Igniters and Tracers", PATR **1335**(1943) (See also Refs 8 & 12a)
- 10) M.M. Johnson & C.T. Haven, "Ammunition: Its History, Development and Use 1600-1943", W. Morrow (1943), pp 21-68, 88-159 & 189-208 10a) J. Newman, "The Tools of War", Doubleday, Doran & Co, NY (1943), pp 11-46 & 69-96 (History of development in the world of ammunition and weapons)
- 11) R.L. Grant, "Structural Features of Typical American Commercial Detonators", USBurMines **RI3696**(1943)
- 12) Anon, "Ammunition Inspection Guide", TM 9-1904 (1944), p 20 (Definition of primer); 125 (High-explosive train); 181-84 (Small arms primers); 235-39 (Fuzes for hand grenades); 241-50 (Firing devices for anti-personnel mines and booby traps); 257 (Fuze for rifle grenade); 259-60 (Fuze for 2.36-inch rocket); 263-67 (Fuze for antitank mine); 270 (Detonator for bangalore torpedo); 272 & 274 (Trench mortars, historical); 276 (Ignition cartridge and fuze for 3-inch trench mortar ammo); 279 & 283 (Ignition cartridges for 81-mm trench mortar); 291-318 (Trench mortar fuzes); 319-23 (Artillery fuzes-historical, classification and forces available to cause artillery fuzes to function); 326-28 (Percussion primers: American M36 and Berdan M37 for 20-mm shells); 328, 337, 340-42, 356-57, 369-76, 383-99, 435-44, 455-56, 462, 469-71, 484, 497-502, 525 & 532-33 (Fuzes for various caliber artillery ammo); 331-35, 364-66, 403-07, 510, 528 & 541-45 (Primers, percussion for various caliber artillery ammo); 557-62, 580-91 & 606 (Bomb fuzes); 579-80 (Primer-detonators for bombs); 623-32 (Depth bomb fuzes); 643-52 (Fuzes for fragmentation bombs); 668-71 (Chemical bomb fuzes); 677-78 (Incendiary bomb fuzes); 720-21 (Flare fuze); 723, Fig 282 (Primer for airport flare); 725, Fig 283 (Built-in fuze for photo-flash bomb) 12a) K.S. Warren, "Compilation of Data on the Composition of Foreign Primers and Detonators", PATR **1450**(1944) (See also Refs 8 & 9a)
- 13) Vivas, Feigenspan & Ladreda **4**(1944) 295-306 [Cebos o cápsulas fulminantes (primers)]; 306-07 [Mechas (fuzes)]; 307-21 (Detonadores-simples, compuestos, completos y electricos)
- 14) Pérez Ara (1945), Chapter 24, pp 647-89 [Disposición y procedimientos para la iniciación de las explosiones. It includes description of mechas (fuses), cebos (primers), cápsulas detonantes (blasting caps), detonadores, estopines (propellant primers) and espoletas (fuzes)]

- 15) Anon, "Ammunition General", **TM 9-1900** (1945) (It is superseded by later editions such as of 1956, listed here as Ref 32)
- 15a) P.P. Karpov, "Sredstva Initsirovaniya" (Initiating Means), GosIzdatOboronProm, Moscow (1945)
- 15b) P.F. Bubnov & I.P. Sukhov, "Sredstva Initsirovaniya", Oborongiz, Moscow (1945)
- 15c) Thorpe's **7** (1946), 530 (Fuzes)
- 16) Vivas, Feigenspan & Ladreda **2** (1946), 351-57 (Mezclas fulminantes - fulminating mixtures)
- 17) Ohart (1946), 12 & 45 (Primers, definition); 19-20 (The explosive train); 35 (Initiators, definition); 46 (Primer mixtures); 46-48 (Fuze type primers); 48-50 (Testing of primers); 51-54 [Artillery primers: percussion, electric, and combination (electric & percussion)]; 54-55 (Trench mortar primers and ignition cartridges); 55-57 (Detonators: three-part and two-part); 57-59 (Testing of detonators); 59-60 [Commercial-type squibs (igniters) and detonators]; 61 (Igniter for tracers); 74, Fig 29 (Primer in small arms ammunition); 77 (Igniter composition for tracers); 80 (Small arms primer); 122-27 (Artillery fuzes: definition; detonator safety, fuze explosive trains, forces in gun affecting fuze action, requirements of a satisfactory fuze, classification of fuzes and fuze materials); 127-38 (Fuze arming: definition, how accomplished, further arming considerations, design formulas and fuze design tests); 138-43 [BD (base-detonating) fuzes]; 143-50 [PD (point-detonating) fuzes]; 150-60 [Standard interchangeable point fuzes, which include point fuzes, time fuzes (powder-train and mechanical-time fuzes)]; 160-65 (Mortar fuzes); 169-70 (Fuzes for false-ogive projectiles); 184 (Igniter pads for separate-loaded ammo); 218-19 (Bomb explosive train); 248-50 (Bomb fuzes); 251-54 (Bomb fuze arming); 254-56 (Classification of bomb fuzes); 256-72 (Nose bomb fuzes); 273-90 (Tail bomb fuzes); 275-77 (Primer-detonators for GP bombs); 296-97 (Pyrotechnic ignition train); 334-40 (Rocket fuzes); 334, 340-41 & 346 (Rocket igniters); 356-57 (Hand grenade fuzes); 357-58 (Rifle grenade fuzes); 364, Fig 208 (Antitank mine fuzes); 366, Fig 211 (Chemical fuze for A/T mine); 367-70 (Firing devices for antipersonnel mines and booby traps); 374-75 (The M1 bullet impact fuze for destructors)
- 17a) Shilling (1946), 12, Table 20 (Rus percussion comps); 144-47 (Rus detonators); 156-57 (Rus electric primers & detonators)
- 17b) Anon, "Small-Arms Ammunition", **TM 9-1990** (1947), 59-61 (Primers)
- 18) Stettbacher (1948), 95-104 (Zündsprengstoffe oder Initialexplosivstoffe); 105-06 (Sprengkapseln); 106-07 (Zündhütchen); 107-08 (Zündschnüre); 130-32 (Sabotage devices includes 2 refs)
- 19) A.D. Blinov, "Kurs Artillerii" (Artillery Course), VoenIzdat, Moscow (1948-1950). Total 12 volumes, of which Vols 1 and 2 deal with explosives and ammunition
- 19a) A.I. Lur'ye, "Promyshlenniye Elektrodetonatory" (Industrial Electric Detonators), UgleTekhIzdat, Moscow (1949)
- 19b) Anon, "Bombs for Aircraft", **TM 9-1980** (1950), 8-9 (Bomb explosive train), 18-25, 40-1 & 60 ff (Bomb fuzes); 26 & 61-2 (Primer-detonators) (Superseded by Ref 51a)
- 20) A. Izzo, "Pirotecnica e Fuochi Artificiali", Hoepli, Milano (1950), 43-51 (Igniting devices for pyrotechnic cartridges)
- 20a) Anon, "Artillery Ammunition", **TM 9-1901** (1950). It was superseded by **TM 9-1300-203** (1967), listed here as Ref 52
- 20b) ADL, Synthesis HE's **2** (1951), 329 (Compn of DuPont No8 Commercial Detonator)
- 21) Stettbacher (1952), 124-33 (Explosivos de iniciacion); 134-39 (Cebos o cápsulas detonadores - Blasting caps); 137 (Estopinas - Primers used in small arms cartridges); 137-38 (Mechas - Fuses); 164-66 (Sabotage devices; includes 3 refs)
- 22) Belgrano (1952), 193-96 [Micce (fuses)]; 199-246 [Esplosivi primari o innescanti (primary or initiating expls)]; 247-50 [Detonatori da mina (blasting caps)]; 251-52 (Principali prove da eseguirsi sui detonatori); 252 (Detonatori elettrici); 307 (Accenditori e detonatori elettrici)
- 22a) Taylor (1952), 11 (ASA and Briska detonators)
- 23) Anon, "Ordnance Explosive Train De-

signers' Handbook"; US Naval Ordnance Laboratory, **NOLR 1111** (1952), pp 2-3 to 2-8 (Primary expls); 2-9 to 2-11 (Priming mixtures); 2-16 to 2-17 (Gasless igniters); 2-21 (BkPdr fuses); 2-21 to 2-22 (Quickmatch); 3-1 to 3-9 (Stab primers); 3-10 to 3-22 (Percussion primers); 3-22 to 3-54 (Electric primers); 4-1 to 4-8 (Flash detonators); 4-8 to 4-14 (Stab detonators); 4-14 to 4-22 (Electric detonators). Chapter 5, pp 5-1 to 5-51 "Characteristics of Delays and Delay Elements". Its contents were listed in Vol 3 of this Encycl, p D52-R but no description was given); pp 5-27 to 5-30 (Primers used in delay elements); 5-30 to 5-31 (Delay detonators); 5-50, Fig 5-39 (Electric delay fuze primer Mk 115); 5-51, Fig 5-40 (Electric delay detonator Mk 35, Mpd 1); 5-52, Fig 5-41 (4 to 6-second experimental obturated percussion delay detonator); 5-59, Fig 5-44 (Flame initiated 0.10-second flash detonator); 5-60, Fig 5-45 (Stab initiated 0.02-second delay detonator); Chapter 6, pp 6-1 to 6-11, "Characteristics of Leads" (It is included here because *leads* are parts of fuzes. A lead is defined as *that explosive component of the firing train of a fuze which is located between the detonator and the booster*); Chapter 7, pp 7-1 to 7-25, "Characteristics of Boosters" (It is included here because at the time of description of Boosters in Vol 2 of this Encycl, p B243 to B246, the Handbook NOLR 1111 was classified confidential); p 7-10, Fig 7-7 (Gap test for detg booster sensitivity); 7-11, Table 7-1 [Sensitivity test values for possible booster explosives. The tests include: Impact test (H₅₀ in cm); Minimum priming charge test (grams of Diazodinitrophenol) and Gap test (inches of wax)]; Chapter 8, pp 8-1 to 8-37, "Interaction of Explosive Train Components"; Chapter 9, pp 9-1 to 9-56, "Measurement Techniques" (It includes various tests for primers and detonators, such as Drop weight test, Lead disk, Hopkinson bar, Stauchapparat, Gap tests and Insensitive explosive tests); Chapter 10, pp 10-1 to 10-26, "Loading" (It includes description of loading of primers, detonators, delay elements

and boosters) 23a) Anon, "Fundamentals of Firearms"; **TM 9-2205** (1952), pp 3-25 (History of development of small arms); p 29, Fig 21 (Percussion and electric primers in small arms ammunition)
 24) Anon, "Soviet Projectile Identification Guide"; **TM 30-240** (1953) (Conf, Not used as a source of info)
 25) A.B. Schilling et al, "Soviet and Satellite Fuzing Mechanisms"; PicArnsMemReport **MR-23** (1953) and Amendments
 26) Anon, "British Explosive Ordnance"; **TM 9-1985-1** (1952) (Conf, Not used as a source of info)
 27a) Anon, "German Explosive Ordnance" (Bombs, Fuzes, Rockets, Land Mines and Igniters), **TM 9-1985-2** (1953), *German Bomb Fuzes*, which include: pp 125-32 (Electrical fuzes; 132-34 [Mechanical clockwork, (41) A]; 134-35 (Mechanical impact nose & tail); 135-38 (Mechanical impact and breakup); 141-45 (Electrical impact); 145-46 (Mechanical impact tail); 146-48 (Special impact); 149-52 & 162-68 (Electrical impact); 152-55 (Electrical clockwork time); 155-56 & 159-62 (Mechanical clockwork time); 157 (Electrical chemical time); 168-69 & 171-72 (Mechanical aerial burst); 169-71 (Rocket bomb fuzes); 172-74 (Electrical aerial burst); 175-78 (Clockwork aerial burst); 177 & 179-81 (Mechanical antiwithdrawal, ZUS40, Types I, II & III); 181-85 (Electrical anti-disturbance); 185-89 (Clockwork antidisturbance); 187 (Chemical-mechanical long delay and antidisturbance); 189-91 [Mechanical impact, "all-ways" action, VS(80) and (80)A]; 191-92 (Dust fuze for Ger SD4 & 10 bombs) [A simple comprehensive description was given in Ref 35, pp Ger 38 & 39; 217 (Fuze for X-4 rocket); *German Rocket Fuzes* are listed on pp 217, 221, 226, 227-29, 232, 239 & 240
German Fuzes and Igniters for Land Mines and Grenades. The following are described: p 261 (Igniter for Pappmine A/T; 264 (Fuze for Holzmine, A/T; 265 (Igniter for Sprengriegel 8-kg A/T); 266 (Igniter for heavy A/T mine); 268 (Igniter for Tellermine 35, A/T); 269-70 (Igniters for Tellermine 42 & 43); 272 (Igniter for Topfmine A, A/T);

273 (Igniters for RMine, A/T); 274 (Igniter for Aluminum A/T or A/P mine); 275-76 (Igniter for Glassmine 43, A/P); 276 (Igniter for B-Stabmine, A/P); 278 (Fuze for concrete ball mine, A/P); 279 (Igniter for Behelfsmine W-1, A/P); 280 (Fuze for S-Mine 35, A/P); 282-83 (Liquid igniter for mustard pot mine, A/P); 283-86 (Friction igniters BZ 24, BZE, BZ 39, ZDSCHN-ANZ 39 & ANZ 29); 287-88 (Safety fuse igniter, percussion type); 288 (Pull percussion igniter); 288-89 (ZZ 35 pull igniter); 289-90 (Type 31 pull igniter); 290-92 (ZUZZ 35 pull and tension release igniter); 292-93 (ZDZ 29 pressure, pull type, igniter); 293-94 (ZZ 42 pull or pressure type igniter); 294-95 (SMiZ 44 push-pull igniter); 295-96 [DZ 35 (A) & DZ 35 (B) pressure igniters]; 296-97 (Schuko pressure igniter); 297-98 (PX 32 pressure igniter); 298 (Weissmann pressure igniter); 299 & 301 (SMiZ 35 pressure igniter); 300-01 (ESMiZ 40 electric pressure igniter); 301-05 (TMiZ 35, 42 & 43 pressure igniters); 305-06 [MiZ 530 (e) pressure igniter]; 306-07 (Topf pressure igniter); 307 (FiEsMiZ, pressure igniter); 307-08 (All-explosive device, pressure release type); 308-09 (Buck igniter, chemical crush-actuated type); 309-10 (Long-delay igniter, clockwork type); 309, 311 & 313 (J-Feder 504, clockwork, long delay igniter); 312-14 (CMZ 41W chemical-mechanical delay igniter); 314-15 (Kippzünder 43, tilt-type igniter); 315-16 (New tilt igniter, pressure-type); 316-18 (Knickzünder 43, Types I & II, snap igniters); 332-33 (Friction igniter for A/P hand & rifle grenades); 334-35 (Fuze for A/T shaped charge rifle grenade); 335 (Fuze for 37-mm shaped charge rifle grenade); 337 (Fuze for large A/T rifle grenade
27b) Anon, "German Explosive Ordnance" ("Projectiles and Projectile Fuzes"), **TM 9-1985-3** (1953), p 545-623 (Fuzes are listed in Section 5, Part C, under "Foreign Artillery Fuzes of WWII")
28a) Anon, "Japanese Explosive Ordnance" (Bombs, Bomb Fuzes, Land Mines, Grenades, Firing Devices and Sabotage Devices), **TM 9-1985-4** (1953):

Japanese Army Nose Bomb Fuzes, pp 122-36 & 144-51 [Fuzes, instantaneous or short delay: Type 93 A-2(a), Type 12-Year A2(b), Type 99 A-2(c), Type 1 A-2(d), Type 92 A-4(a), Type 3 A-6(a), Type 3 A-6(b), Type 2 A-7(a), Type 4 A-8(a) and Type 4 A-8(b); Type 1 long-delay fuze C-3(a), Aerial-burst D-1(a) & D-1(b), D-5(a), D-5(b) and Remote control radio fuze]

Japanese Army Tail Bomb Fuzes, pp 137-44 & 151-53 [Type 12-Year instantaneous fuze B-1(a), Type 1 15-second delay fuze B-1(b), Type 92 instantaneous fuze B-4(a), Types B-5(a), B-7(a) and B-8(a)]

Japanese Navy Nose Bomb Fuzes, pp 155-67 & 181-82 [A-1(a), A-1(b) & A-1(c); Type 97 Mk2Mod2 A-3(a), Type 1 Mod A-3(b), Type 2 nose initiator A-3(c), Type 97 Mk2Mod1 A-3(d) & A-3(e); Type 2 No 50 Mod 1 A-3(f) & A-3(g); A-5(a), Type 99 C-2(a), Aerial burst D-3(a), Type O Parachute Flare Mod 1 D-4(a) and Type 3 electric firing device]]

Japanese Navy Tail Fuzes, pp 168-80 & 182-85 [Type 99 No 25 B-2(a), Type 99 No 80 Mk 5 B-2(b), Type 15 Mod 2 B-3(a), Type 15, Mod 2 B-3(b), B-5(b), B-5(c), B-6(a), B-10(a), C-1(a), D-2(a), D-2(b) and D-2(c)]

Japanese Land Mine Initiating Devices are shown in pp 202, 205, 207, 208, 209, 210, 212, 216, 217, 219, 221 & 223

Japanese Grenade Initiating Devices are shown in pp 224, 226-37, 240, 242, 243, 245 & 246.

Japanese Firing and Sabotage Devices are shown in pp 246, 248, 250-52, 256-58 & 260 28b) Anon, "Japanese Explosive Ordnance" (Army Ammunition, Navy Ammunition), **TM 9-1985-5** (1953): Army projectile fuzes (pp 391-426); Navy projectile fuzes (pp 518-43). They are listed in Section 5, Part C, under "Foreign Artillery Fuzes of WWII"

29) Anon, "Italian and French Explosive Ordnance"; **TM 9-1985-6** (1953):

Italian Bomb Nose Fuzes, Mechanical Impact, pp 29-39: Types A, B, V, F, W, J, L, M, Q & R and pp 58-59: Type "Orphan"
Italian Bomb Tail Fuzes, Mechanical Impact,

pp 40-49: Types C, C-1, E, G, H, N, N-1, N-2, N-3, Y, Y-1, O, P & Z and pp 54-55: Types T-2 & O-2

Italian Bomb Nose Fuzes, Mechanical Time, pp 49-50: Types 1 & T

Ditto, Electrical Time, p 51: Type X

Ditto, Clockwork Long-Delay, pp 52-53: two types for use in 500-kg time bombs

Italian Tail Fuzes, pp 55-56: Type for use in shaped-charge bomb and Hydrostatic Type "Grand Daddy"

Italian Mechanical Antidisturbance Fuze-Mansolini, pp 59-60

Italian Detonators, p 132: Types M Cortese, M10 (Allegenti) and M10

Italian Projectile Fuzes are listed in Section 5, Part C, under "Foreign Artillery Fuzes of WWII"

Italian Bomb Nose Fuzes, Time, pp 144-45, 147-48 & 151-52: M900/14, M900/34, OT32, M06/17, M36 & OT33

Nose Fuzes, Time and Percussion, pp 146-50: ADE M99, ADE M06, ADE M12, ADE M36 & ADE M32

Italian Bomb Base Fuzes, pp 153-54: for 47/32 AP shell & for 100/17 Shaped Charge shell

Italian Igniters, pp 173-76: Chemical Delay Igniter (for demolition charges), Time Delay (Lead shear wire), Friction Delay (Micca Da 40 & 60) & 50-Day Clock

French Bomb Fuzes, Mechanical Impact Nose, pp 189-200: Type A, Type H, Type RSA Models 1925, 1928, 1929 & 1930, Type MBis, Nos 9, 10 & 11

Ditto, Tail Fuzes, pp 201-03; No 3 Bis, SchR Mod 1938 and No 7

Ditto, Mechanical Time, Tail, pp 204-05: Mod 1930 and VM

French Igniters, pp 210-13: Rupture, Pull Mod 1939 and Push Models

29a) A. Izzo, "Manuale del Minatore Esplosivista", Hoepli (1953), 67-74 (Micce a lenta combustione); 74-7 (Capsule da mina ordinarie, which include description of Ital caps Nos 6, 7, 8 & 10); 77-8 (Detonatori di produzione estera, which includes detonators of Sellier-Bellot of Prague, Dynamit AG at Troisdorf, Schafler of Vienna and Nobel Co in Glasgow); 84 (Micce a rapida

combustione of Società Sipe e Montecatini); 85-91 (Micce detonanti); 94-5 (Accenditori elettrici); 95-101 (Inneschi elettrici); 102 (Detonatori elettrici per ricerche geofisiche);

114-21 (Preparazione delle cartucce innesco)

30a) Anon, "Soviet Fuzes for Aircraft Funs, Mortars and Artillery Weapons"; Ordnance Industrial Division Manual **ORDI 7-102**

(1954) (Not used as a source of information)

30b) Anon, "Military Explosives"; **TM 9-1910** (1955), pp 93-118 (Initiating agents used in military ammunition); 267-69 (Identification of initiating agents); 292-93 (Igniters for tracers); 295-96 (Packing of initiating agents)

30c) Anon, "Demolition Materials"; **TM 9-1946** (1955), 47-55 (Priming and initiating components); 58-81 (Firing devices); 81-2 (Percussion primers); 82-3 (Military blasting caps); 130-31 (Fuze, bullet impact, M1)

31) B.T. Fedoroff et al, "Dictionary of Russian Ammunition and Weapons"; **PATR 2145** (1955) & **OTS PB 159927** (1955). Figs on the sheet betw pp 2 & 3 include Rus

Detonator MD-2, Pressure Fuze MV-5, Delay Fuze ChMV-10, Pull Fuze MUV and Pull Fuze VPF; p Rus 4 (Kapsuli detonatory-Detonator caps), Rus 4 & 5 (Rus detonators used during WWII); Rus 6 (Elektrozapaly i Elektrodetonatory - Electric primers and Electric detonators); Rus 6 (Zazhigayushchiye sostavy - Igniting or flashing compositions); Rus 7 (Detoniruyushchiye shnury - Detonating fuses); Rus 7 & 8 (Vzryvateli - Fuzes); Rus 12-13 (Udarnyiye sostavy - Percussion compositions); Rus 16 (Udarnyiye i initsiiruyushchiye sostavy - Priming & initiating compositions); Rus 19 (Propellent igniter compositions); Rus 22 & 23 (Tracer igniter compositions) 31a) B.A.

Rausch "Development of a Substitute Primer Mixture for M2 Ignition Primer Cartridge"; **PATR 2299** (1956) 31b) Anon, "Ground Chemical Munitions"; **TM 3-300** (1956)

32) Anon, "Ammunition General"; **TM 9-1900** (1956), p 43, Fig 25 (Explosive train, artillery ammo); 59-60 (Initiating and priming expls); p 104, Fig 68 (Fuzes for hand grenades); pp 131-39 [Fuzes, artillery, such as BD (Base-detonating) M91A1; PIBD (Point-initiating base-detonating) M90A1;

PD-SQ DEL (Point-detonating impact super-quick and delay), PD-MTSQ (Point-detonating mechanical time and superquick), PD VT (Point-detonating proximity), PD MT (Point-detonating mechanical time and Concrete-piercing fuzes); 139-42 (Primers, artillery, such as percussion and combination electric & percussion); p 163, Fig 113 (Nose & tail explosive train of an HE bomb); 172-79 [Bomb fuzes, such as arming-vane-type, arming-pin-type, mechanical time, impact, hydrostatic and proximity (VT)]; 191, Fig 139 (Fuze in flare, trip, parachute, M48); 192, Fig 140 (Trigger Mechanism in flare trip M49); 196, Fig 144 (Primer in signal, distress, two star, red, AN-M75, T49); 239, Fig 172 (Fuze, mine, combination M6A1 in A/P mine M2A4); 240, Fig 173 (Fuze, mine, combination M605 in A/P mine M16); 241, Fig 174 (Fuze, integral in A/P mine NM M14); 242, Fig 175 (Fuze, combination M10A1 in A/P practice mine); 252, Fig 182 [Fuze, mine A/T, M603 (T17E2)]; 253, Fig 183 (Firing device, pull type for heavy service A/T mines M15 & M6. The device works in conjunction with Activator M1 shown in Fig 184, p 254, thus forming a secondary

fuze); 268, Fig 194 & p 269 (Detonator, concussion type, M1 for use in destructors); 269, Fig 195 & p 270 (Detonator, friction igniter, 8-second delay, M2); 270, Fig 196 & p 271 (Lighters, fuse, safety type, M1 & M2); 273, Fig 200 & pp 274-75 (Firing devices for detonating cords); 276, Fig 201 & p 277 (Blasting caps used for military purposes); 288, Fig 212 (Fuze, bullet impact M1A1 for snake demolition, M3); 295-96 (Fuzes for guided missiles); 302 (Initiators for cartridge-activated devices) 32a) R.T. Eckenrode & H.A. Kirschner, "Small Arms Electric Primer Functioning", Frankford Arsenal Report No **R-1309** (1956) (Conf) (Not used as a source of info) 32b) Anon, "Land Mines", TM **9-1940** (1956), pp 24-5, 34-5, 38-9, 43-4, 53-62, 69-70, 77-81, 85-6, 103-04 & 108 (Fuzes); 110-13 (Activators); 121-28 (Detonators); 128-52 (Firing devices); 152 (Percussion primer); 159 (Lighter for fuses) 32c) B.A. Rausch, "Development of a Substitute Primer Mixture for the M2 Igniter Cartridge Primer", PATR **2299** (June 1956) [The purpose of this work was to develop a substitute for mixt covered by USP 2480141. This mixt consists of basic Pb styphnate 40, Ba nitrate 42, Sb

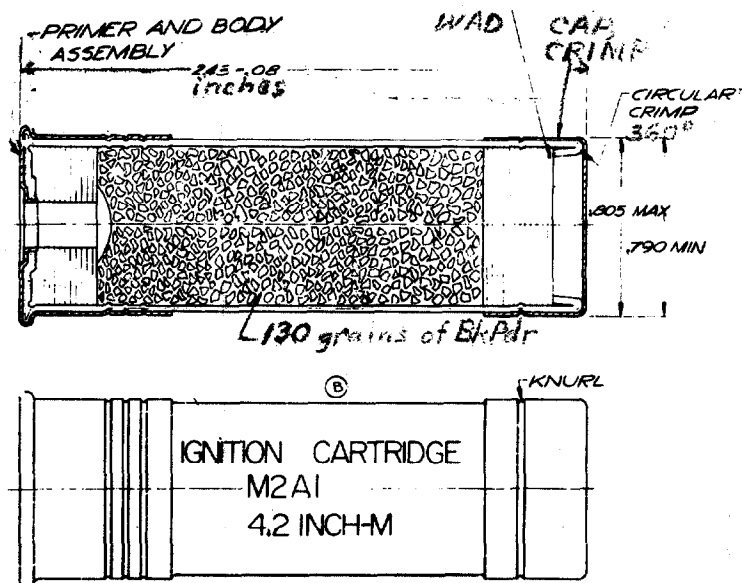

Fig 1 IGNITION CARTRIDGE M2A1

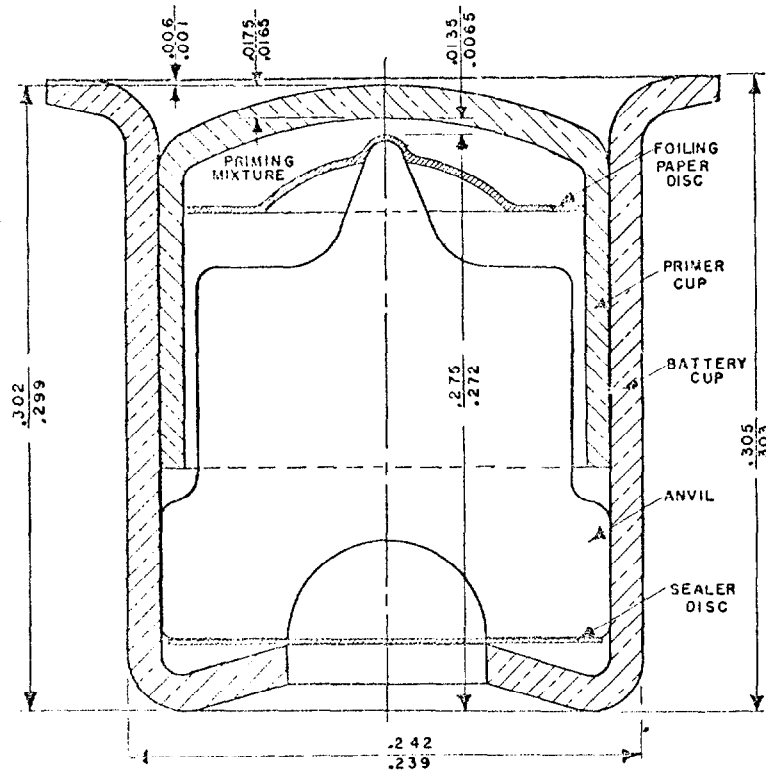

Fig 2 M2 IGNITION CARTRIDGE PRIMER

sulfide 11, NC 6 & Tetracene 1%. Cartridge is shown in Fig 1, while its igniter-primer in in Fig 2. After examining several mixts controlled by the US Govt, it was decided to try the compn NOL No 60 developed by US Naval Ordnance Laboratory. The compn of this mixt is: basic Pb styphnate 60, Ba nitrate 25, Sb sulfide 10 & Tetracene 5%. This mixt was found to be satisfactory except that it was not suitable for wet-loading, the technique generally used in mass-loading. In order to make the NOL No 60 suitable for that purpose it was modified at PicArnsn by wetting 100-g of mixt with 26-g of a soln of 0.5/0.5/99 - gum arabic/gum tragacanth/water binder and then loading into primers as described on p 5 of the report. The tests for primers loaded with this mixt included impulse, gas volume, average peak & delay and stability in storage]

33) A.G. Gorst, "Porokha i Vzryvchatyiya Veshchestva" (Propellants and Explosive

Substances), GosIzdatOboronProm, Moscow (1957), pp 14-15 (Initiating devices, historical); 107-10 (Initiating expls); 111-30 (Description of various primers, detonators and fuzes) 33a) R.L. Eichberg, Ordn 42, 67-8 (1957) ("Ballistic Missile of 1845") (A method devised by Lieut Henry Moor, US Navy, for detonating a mortar shell during its flight toward the target, by using trailing wires and a galvanic battery) 34) S.F. Vaskovskii, "Prakticheskoye Rukovodstvo po Obrashcheniyu s Vzryvchatymi Veshchestvami" (Practical Instruction for Handling Explosive Materials), GosGeolog-TekhIzdat, Moscow (1957); 37-8 (Initiating explosives); 39-43 (Detonators); 43-4 (Detonating fuse); 44-5 (Safety fuse); 45-6 (Igniters of safety fuse); 103-06 (Testing of detonators); 106-08 (Testing of fuses); 108-09 (Testing of igniters); 120-24 (Precautions to be taken in manuf of initiating devices) 34a) A.I. Lur'ye, "Elektricheskoye Vzryvaniye Zaryadov" (Electrical

Initiation of Explosive Charges), UgleTekh-Izdat, Moscow (1957) (290 pp) 34b) R. Goldstein, "Techniques for Button-Type Electric Detonators T21E1 and T25E1", PicArnsEngrg-DivTechPaper **DB-TP-1-57** (1957)

35) B.T. Fedoroff et al, "Dictionary of Explosives, Ammunition and Weapons" (German Section), PATR **2510** (1958) Ger 1-3 (Aerial-burst fuzes); Ger 7-8 (Anti-break-up fuze); Ger 8-9 (Antidisturbance fuze); Ger 9-10 (Antiwithdrawal fuzes); Ger 20 (Bomb high-explosive train); Ger 33 (Delay compns); Ger 33-34 (Delay elements); Ger 34-35 (Detonators & blasting caps); Ger 38-39 (Dust fuze); Ger 40-41 (Electric fuzes); Ger 41-2 (Electric igniters and primers); Ger 42 (Electric matchhead); Ger 44 (Eschbach igniter); Ger 53-54 (Fuseheads and their manuf); Ger 54-56 (Bomb fuzes); Ger 56-64 (Projectile fuzes); Ger 63 & 65, Table 17 (Fuze trains); Ger 63 & Ger 66 (Gasless delay detonator); Ger 86 & Ger 93 (Igniters for grenades); Ger 93-99 (Igniters for land mines); Ger 99 (Igniter bags); Ger 136-137 (Primary and initiating compositions); Ger 137-38 (Primers); Ger 151 (Propellant igniters and propellant igniter bag compositions); Ger 151-52 (Proximity fuzes); Ger 164 (Rocket bomb fuze assembly); Ger 166 (Rocket propellant igniter); Ger 174-175 (Self-destroying fuze); Ger 199-202 (Igniters for tracers described under Tracer Compositions); Ger 215 (V-22 Delay-igniter unit)

36) Taylor & Gay (1958), pp 52-3 (Initiating expls); 53-4 (Commercial detonators); 54-6 (ASA/Tetryl & ASA/PETN detonators); 56-65 (Electric detonators); 69-74 (Delay detonators); 150, Fig 35 [Diagram of detonating relay for use in "opencast coal mining"; called in US "strip-mining"]; 151 (Description of detonating relay); 150-51 (Detonating fuze) 36a) Anon, "Rockets"; **TM 9-1950** (1958), pp 2-4 (Introduction); 5-32 (General discussion and terminology); 33-47 (3.5-inch Ground Rockets); 48-53 (4.5-inch Ground Rockets for Multiple Launcher); 54-55 (4.5-inch Ground Rockets for Expendable-Type Launcher); 55-61 (Time and Impact Fuzes for Ground-Type Rockets); 61-69 (VT Fuzes for Ground-Type Rockets);

70 (2.0-inch Aircraft Rockets); 70-74 (2.5-inch Aircraft Rockets); 74-78 (2.75-inch Aircraft Rockets); 78-102 (5.0-inch Aircraft Rockets); 103-10 (Time and Impact Fuzes for Aircraft Rockets); 110-22 (VT Fuzes for Aircraft Rockets); 123-30 (Solid Rocket Propellants); 131-33 (Demolition of rockets and components to prevent enemy uses)

37) Anon, "Military Pyrotechnics"; **TM 9-1370-200** (1958), p 59, Fig 23 (Fuze M6A1 for Flare, surface, parachute M48); pp 64-71 (Fuzes for parachute flares, such as AN-M146, AN-M146A1, MIII, MIIIA1, MIIIA2, AN-M146A1C & M155); 102, Fig 45 (Igniter & quickmatch for signal, smoke, marine, AN-Mk1Mod1); 103, Fig 46 (Igniter for signal smoke & illumination, marine AN-Mk13-Mod0); 122, Fig 61 (Igniter, ram-jet engine M132 90-second)

38) McAdam & Westwater (1958), 9-10 (Detonators, historical); Chapter 5, "Blasting Accessories"; pp 51-2 (Safety fuze); 52-3 (Plain detonators, including ASA-Tetryl and ASA-PETN); 52-9 (Electric detonators); 54 (Fusehead); 59 (Electric powder fuses); 59-60 (Detonating fuses); 60 (Detonating relays); 61-2 (Plastic igniter cord); 62-4 (Exploders); 70-3 (Primer cartridges; combination of plain detonator and safety fuze is called *capped fuze*); 73-6 (Charging shot-holes; direct and indirect initiation); 76-7 (Firing with safety fuze); 77-83 (Firing electrically); 83-5 (Firing with detonating fuze); 160-61 (Igniting shots); 160, Fig 71 (Plaster shooting with plaster igniter cord) 38a) Giua, Trattato **6**(1) (1959), 414-31 (Sostanze innescenti); 431-32 (Miscete detonanti) 38b) Glossary of Ord (1959), 3-4 (Actuator)

39) W.G. Chace & H.K. Moore (eds), "Exploding Wires", Vol 1, Plenum Press, NY (1959) (Application in initiating devices)

40) Anon, "Ammunition for Recoilless Rifles"; **TM 9-1300-204** (1959), 29-30 (Fuzes for recoilless rifles; classification); 30-1 (Detonators in various fuzes); 31 (Fuze interchangeability); 31-41 [Fuzes: BD M62A1, BD M91A1 or M91, Dummy M73, Dummy T126, Inert M89, MTSQ M500A1 or M500, PI M90A1 or M90, PIBD M509, PD M48A3 (0.05-Sec

- Delay), PD M51A5 or M51A4 (0.05-Sec Delay), PD M57, PD M89 and PD M503A2, M503A1 or M503]; 42-3 (Primers: M46, M47, M47B1, M57 and M60A1); 43-5 (Booster M21A4 which is an integral part of PD fuzes M51A5 & M51A4 and of MTSQ fuzes M500A1 & M500) 40a) Anon, "Nomenclature and Definitions in the Ammunition Area", Military Standard, **MIL-STD-444** (1959) (1963) & (1964) 40b) Anon, "Ammunition for Antiaircraft, Tank, Antitank and Field Artillery Weapons", **TM 9-1300-203** (1960), pp 3 to 17 (Definitions); 18 to 77 (Cartridges for 37-mm, 40, 75, 76, 90, 105, 120, 155 & 280-mm, and 8-inch weapons); 77 to 102 (Projectiles for 120-mm, 155 & 280-mm and 8-inch weapons); 103-59 (Fuzes); 160-75 (Propelling charges, flash reducers, etc); 175-86 (Primers); 186-91 (Adapters and boosters); 191-92 (Bursting); 192-96 (Eyebolt lifting plugs, closing plugs and grommets); 197-98 (Destruction of ammunition to prevent enemy use)
- 41) Anon, "Ammunition for Mortars", **TM 9-1300-205** (1960); 7-15 (Types of fuzes, igniters and primers used in 60-mm mortar rounds); 15-28 (Ditto in 81-mm mortars); 28-41 (Ditto in 4.2-inch mortar); 42-80 [Description of fuzes: Mechanical Time and Superquick- M500A1 (or M500), M501A1 (or M501), and M520; Point Detonating - M8, M9, M51A5 (0.05-Sec Delay), M52-Series, M53A1, M82, M82A1, M82A1B1, M519, M521 (T247), M524 (T186E11), M525A1, M525, M526A1, M526, M527A1, M527, M527B1, M527A1B1 and M535 (T177E3) (0.05-Sec Delay); Time fuzes - M65A1, M65 and M84; Time and Superquick - M77; Proximity fuzes: M513A1 (T226E2), M517 (T178E3) and M517 (E3)]; p 43, Fig 21 (Detonators M17, M18, M24 & M44); p 46, Table II (Dimensions of detonators M17, M18, M19A3, M22, M24, M29, M44, T33E1 and T34A1); pp 84-8 (Ignition cartridges M2, M3, M4, M5A1, M6, M8 & M66; Percussion primers M32, M34, - M71 and M71E1); 88 [Booster M21A4 - an integral part of mortar fuzes M51A5 & M500A1; Booster M124 (T35E7) - an integral part of fuze M520]
- 42) Anon, "Small-Arms Ammunition", **TM 9-1305-200** (1960), p 4, Fig 1 (Primer assembly and cartridge terminology); 24-25 (Primers); Fig 14 (Components of primers-separated); Fig 15 (Primers-sectioned) 42a) R.R. Potter, "A Method for Protecting Electroexplosive Devices from Spurious Electrical Initiation", USNavalWeaponsLab-TechMemoRept **W-3/60** (1960) (Protection is achieved by inclosing an electroexplosive device in a metallic shield) 43) B.T. Fedoroff & O.E. Sheffield, "Encyclopedia of Explosives and Related Items", **PATR 2700**, Vol 1 (1960), pp A383 to A391 [AMMUNITION AND WEAPONS (OR ARMS)]
- 44) Ditto, Vol 2 (1962), p B112 (Bickford Fuse); B185 to B202 (BLASTING CAPS); B223-R (Bomb High Explosive Trains); B225 to B241 (BOMBS); B242 (Booby trap); B243 to B246 (BOOSTER); C73 to C77 (CARTRIDGE AMMUNITION); C78 to C80 (Cartridge case)
- 44a) H. Ellern, "Modern Pyrotechnics", ChemPubgCo, NY (1961) (Superseded by Ref 57)
- 45) W.G. Chace & H.K. Moore (eds), "Exploding Wires", Vol 2, Plenum Press, NY (1962) (Application of exploding wires in initiating devices) (Vol 3 is listed as Ref 46b) 45a) S.J. Odierno, "Information Pertaining to Fuzes"; AED (Ammunition Engineering Directorate), Pic Arsenal, Dover, NJ, Vol 1 (1963) "Mechanical and Electronic Time Fuzes (Conf) 45b) Ibid, Vol 2 (1963), "Information Pertaining to Propelling Charges"; 45c) Ibid, Vol 3 (1964), "Artillery, Armor Defeat and Mortar Fuzes, PD, BD, PIBD and Time (Pyrotechnic Type)"; 45d) Ibid, Vol 4 (1964), "Explosive Components". It includes:
- Part I Definitions of Fuze explosive train, primer detonator, etc
 - Part II Introduction to Explosive Train
 - Part III MIL-STDs That Control Development of Explosive Components
 - Part IV Characteristics of Electric Detonators
 - Part V Characteristics of Electric Delay Detonators
 - Part VI Characteristics of Electric Primers

| | |
|-----------|--|
| Part VII | Characteristics of Stab Detonators |
| Part VIII | Characteristics of Stab Delay Detonators |
| Part IX | Characteristics of Flash Detonators |
| Part X | Characteristics of Relays |
| Part XI | Characteristics of Booster Leads |
| Part XII | Characteristics of Stab Primers |
| Part XIII | Characteristics of Percussion Primers |
| Part XIV | Booster Pellets, Die Sizes |
| Part XV | Characteristics of Electric Squibs |

45e) S.J. Odierno, "Information Pertaining to Fuzes", Vol 5 (1965), "Fuze Design Safing Philosophy" 45f) Anon, "Land Mines", **TM 9-1345-200** (1964), pp 8-11 (Explosive trains of antipersonnel and antitank mines); 21 (Fuze, Combination Mine, M6A1); 23 (Fuze, Combination Mine, M7A1); 29 (Fuze, Combination Mine, M605); 63 (Fuze, Antitank Mine, M603); 65-71 (Fuze, Antitank Mine, M607); 71 (Fuze, Antitank Mine, M606); 84 (Activator, Antitank Mine, M1 & M2); 85 (Activator, Antitank Mine, M2); 98-100 (Incendiary Bursters); 115 (Fuze in Projected Charge M3A1 used for projecting a detonating cable across the field for mine clearing)

46) Anon, "Demolition Materials", **TM 9-1375-200** (1964), 5 (Demolition explosive train); p 6, Fig 3 (Schematic arrangement of firing device, safeties & components of a booby trap); 9-10 (Firing systems of demolition materials - nonelectric and electric); 32 (Initiating and priming of demolition charges); 32-41 & 43, Fig 43 [Detonators: Friction M1 or M1A1, 15-Sec Delay; Ditto M2 8-Sec Delay and their inert versions. Percussion - M1A2 (M1E1), 15-Sec Delay & M2A1 (M2E1), 8-Sec Delay; Concussion M1 & M1 inert (Detonator kits)]; 45-9 [Time blasting fuse igniters: Friction M1 and Weatherproof M2 & M60 (T2)]; 50, Fig 24 (Primer, percussion M39A1); 50-2 (Time blasting fuse); 52-4 (Detonating cord); 54-69 [Firing devices and components for demolition charges, boobytraps and mines. Types: M1 (Delay), M1A1 & M1 (Pressure), M5 (Pressure release), M1 (Pull), M1 (Release) and M3 (Pull-release)]; 69 (Base, coupling, firing device); 69-70 (Primers, percussion: Cap M2 and Improved No 3); 70-5 (Blasting

caps used in demolition devices) 46a) Anon, "Research and Development of Materiel; Engineering Design Handbook; Gun Series; Gun-General", US Army Materiel Command Pamphlet **AMCP 706-250** (1964), pp 1-1 to 1-3 (Early development of arms and initiation of propelling charges); 2-1 to 2-6 (Present weapons); 3-8 to 3-9 (Ignition of propellant in guns) 46b) W.G. Chace & H.K. Moore (eds), "Exploding Wires", Vol 3, Plenum Press, NY, Vol 3 (1964), pp 125, 158, 175 & 185 (Initiation of detonation of secondary expls by exploding wires) 46c) C. Giorgio, "Tecnica degli Esplosivi", DelBianco, Udine (1964), 26 & 136-45 (Esplosivi innescenti); 162-65 (Miscele di esplosivi innescenti); 186-92 (Mezzi d'innescimento e di accensione); 192-94 (Detonatori comuni); 194-200 (Accensione elettrica); 200-02 (Miccia detonante); 202 (Miccia a rapida combustione); 202-03 (Cordone di accensione); 203 (Sistema misto "elettrocord"); 213 (Detonatori secondari) 46d) R.H.F. Stresau et al, "Confinement Effects in Exploding Bridgewire Initiation of Detonation", 4th ONR SympDeton (1965), pp 449-60 (12 refs) (A resumé of this paper is given in Section 3, Part E, item c)

47) S.J. Odierno, "Information Pertaining to Fuzes", AED (Ammunition Engineering Directorate), PicArns, Dover, NJ, Vol 6 (1966), "Encyclopedia of US Army Fuzes" (Conf) 47a) Ibid, Vol 7 (1966), "Fuze Design Testing Techniques"

48) B.T. Fedoroff & O.E. Sheffield, "Encyclopedia of Explosives and Related Items", **PATR 2700**, Vol 3 (1966), p C325-R (Claessen's primer & detonator mixtures); C529-R to C531-L (Cord, detonating or Cordeau); D49-R (Delay blasting cap); D52 (Delay elements); D93-R to D95-R (Destructors); 97 (Detacord and Detaflex); D100, Fig (DuPont Blasting Caps X-549, E94 & X-570 used for initiation of Detasheet); D103 to D107 (Detonating cords or Detonating fuses); D108-R (Detonating relays)

49) E. Brandimarte, "Le Cariche Scoppio" (Bursting Charge), Poligrafico dell'Accademia Navale, Livorno (1966), pp 3-4 [Definition of terms *innescimento* (initiator, primer) and *catena innescante* (initiating chain, explo-

sive train). Catena consists of *capsula* (cap), contg very sensitive expl which can be initiated either by percussion or electrically. Its expln initiates the 2nd member of catena known as *detonante*, which consists of *carichetta primaria* (small primer, contg small chge of a very sensitive expl, such as MF, LA or SA) and *carichetta secondaria*, which contains a highly brisant HE (esplosivo super dirompente), such as Tetryl, PETN or RDX. Expln of detonante is conveyed to *detonatore o innesco secondario*, which is a compressed cylindrical chge of Tetryl, TNT or phlegmatized PETN or RDX. This corresponds to Amer "booster". The next member of the catena is *cariche di scoppio* (bursting charge); pp 4-5 (Description of detonator designed by Prof Tonegutti); 5-6 [*Spoletta elettrica* - electric fuze, known also as *detonatore ad accensione*. It consists of *bossoletto* (Al alloy cap 7.7-mm diam and 67.2-mm long), *ponticello* (bridge wire), *capocchia incendiava* (igniter head), *carichetta primaria* (primary compn - 0.30 g of LA 70 & Lst 30%) and *carichetta secondaria* (secondary chge - 2.75 g of RDX)]; p 7 (Ital blasting caps known as *detonanti commerciali*, contg MF as a primary chge and TNT as a secondary chge, numbered 1 to 10 are listed in Table 1) 49a) "Pyrofuze", Pamphlet by Pyrofuze Corp, Mt Vernon, NY (1962) & Engineering Data No 66 Series (1966) (Quoted from Ref 57, p 445, Ref 426) 50) Blasters' Hdb (1966), 54-5 (Nitramon-S primer; Nitramon S-EL primer - used in seismographic work); 63-4 (Non NG primers which include Nitramon primers); 64 (Nitramex-3 primer); 64-7 [HDP (High-detonation-pressure) primers]; 67-8 (EL primer s); 87-90 [Electric initiating devices, DuPont EB (Electric blasting) caps]; 90-1 ("SSS" Seismograph electric caps); 91 (Jet Tapper caps); 91-3 (Delay electric blasting caps, which include DuPont Acudet Mark V delays); 94 (Coal mine delay EB caps); 94-5 (Electric squib); 95-9 (Nonelectric initiating devices); 99-101 (Safety fuze igniters or fuze lighters); 101-06 [High energy detonating fuze and accessories, such as "Primacord Bickford", "E-Cord and Primacord MS (millisecond) connectors];

106-10 [LEDC (Low energy detonating cord) and accessories, which include Trunkline Delay Connectors, "LEDCORE" MS Delay Assemblies and "ELCORD" Seismic Delay Units); 185 (Primers used in blasting; definition); 185-99 (Making up primers, which include: BkPdr primers with safety fuse, BkPdr primers with electric squibs or caps, Dynamite primer assembly with blasting caps and safety fuse, Dynamite primers with "LEDCORE" delay assemblies, Dynamite primer assembly with electric blasting caps, Sheathed primers, Priming Dynamite with "Primacord", Priming with "Nitramon" and "Nitramex 3" primers and Priming with HDP primers); 199-200 (Handling primers); 200-05 (Priming charges in boreholes); 205-06 (Priming blasting agents) 51) S. Fordham, "High Explosives and Propellants"; Pergamon Press, NY (1966), 103-07 (Initiating expls); 108-13 (Plain detonators); 113-14 (Testing of plain detonators); 115-24 (Electric detonators); 125-30 (Delay detonators); 131-35 (Detonating fuze); 136-42 (Safety fuze) 51a) Anon, "Bombs and Bomb Components"; Dept of the Army Technical Manual **TM 9-1325-200**; Dept of the Navy Publication **NAVWEPS OP 3530**; Dept of the Air Force Technical Order **TO 11-1-28** April 1966. Following is a list of typical bombs and of their initiating devices: p 1-4, Fig 1-4 (Bomb fuzes in three positions - "safe", "armed" and "fired on impact"); 1-6 to 1-8 (Bomb fuzes: classification, safety features, interchangeability and tactical use); 2-3, Fig 22 [Bomb, SAP (Semi-Armor-Piercing), 1000-lb, AN-M59A showing location of nose and tail fuzes]; 2-8, Fig 2-5 [Bomb, Frag (Fragmentation), 4-lb, M83 with fuze]; 2-10, Fig 2-7 (Bomb, Frag, 20-lb, M41A1 with nose fuze); 2-13, Fig 2-10 (Bomb, Frag, 90-lb, M82 with nose fuze); 2-16, Fig 2-12 (Bombs, Frag, AN-M88 & AN-M81 series, with nose & tail fuzes); 2-22, Fig 2-19 [Bomb, GP (General Purpose) old series, with nose & tail fuzes]; 2-27, Fig 2-20 (Bomb, GP, new series with nose & tail fuzes); 2-29, Fig 2-21 (Bomb, GP, Low-Drag, with nose & tail fuzes); 2-35, Fig 2-24

(Bomb, Incendiary, 100-lb, AN-M47A4, with nose fuze); 2-38, Fig 2-27 (Bomb, Inc, TH3, 4-lb, M126, with firing assemblies); 2-29, Fig 2-28 (Bomb, Inc, PT1, 10-lb M74A1, with nose & tail fuzes); 2-41, Fig 2-29 (Bomb, Fire, 750-lb, M116A2, with nose & tail fuzes and igniters); 2-48, Fig 2-33 (Bomb, Fire, 500-lb, Mk77, Mod 1, with nose fuze and igniter); 2-50, Fig 2-35 (Bomb, Fire, 750-lb, Mk78 Mod 2 with fuzes and igniters located on the sides of the body, near nose & tail); 2-52, Fig 2-37 (Bomb, Fire, 1000-lb, Mk79 Mod 1, with fuzes and igniters located on the sides of the body); 2-56, Fig 2-40 (Bomb, Smoke, PWP or WB, 100-lb, AN-M47A4 with nose fuzes AN-159 or AN-M126A1); 2-58, Fig 2-42 (Bomb, Gas, Nonpersistent, GB, 10-lb, M125A1 with firing mechanism and nose fuze); Note: GB is the filler described in Vol 2 of Encycl, p B147-R; 2-60, Fig 2-43 (Bomb, Gas, Nonpersistent, GB, 500-lb Mk94ModO with nose & tail fuzes); 2-63, Fig 2-45 (Bomb, Gas, Nonpersistent, GB, 750-lb, MC-1 with nose & tail fuzes); 2-65, Fig 2-46 (Adapter, Cluster, Missile, Mk44, showing location of nose fuze); 2-69, Fig 2-49 (Bomb, Aircraft, Depth, 300-lb, AN-Mk54Mod1, showing location of nose & tail fuzes); 2-72, Fig 2-53 (Photoflash Bomb, typical, showing location of nose fuze); 2-78, Fig 2-58 (Bomb, Practice, 5-lb, Mk106ModO, showing location of nose fuze); 2-85, Fig 2-63 (Bomb, Practice, 100-lb, Mk15Mods2, 3 & 4, showing location of tail fuze); 3-7, Fig 3-6 (Cluster, Frag Bomb, 100-lb, M28A2, with nose mechanical time fuze); 3-12, Fig 3-9 (Cluster, Incendiary Bomb, PT1, 750-lb, M35 with tail fuze); 3-12, Fig 3-10 (Cluster, Gas Bomb, Nonpersistent, GB, 1000-lb, M34A1, showing location of tail fuze); Impact Nose Fuzes: 4-3, Fig 4-2 (Nose Fuze AN-M103A1); 4-9, Fig 4-4 (Nose Fuze AN-M126A1); 4-14, Fig 4-8 (Nose Fuze AN-MK219); 4-15, Fig 4-9 (Details of operation of Fuze AN-MK219); 4-18, Fig 4-11 (Nose Fuze MK243ModO or MK244Mod1); 4-22, Fig 4-13 (Nose Fuze M904 series); 4-24, Fig 4-15 (Nose Fuze M142A1); 4-26, Fig 4-17 (Nose Fuze M157); 4-29, Fig 4-22

(Nose Fuze AN-M173A1); 4-31, Fig 4-24 (Nose Fuze M196); 4-32, Fig 4-26 (Nose Fuze M197); 4-37, Fig 4-28 (Tail Fuze AN-M100A2); 4-40, Fig 4-30 (Tail Fuze M115); 4-45, Fig 4-32 (Tail Fuze AN-MK228); 4-49, Fig 4-35 (Tail Fuze AN-MK247); 4-53, Fig 4-37 (Tail Fuze M123A1); 4-58, Fig 4-40 (Tail Fuze M132); 4-61, Fig 4-42 (Tail Fuze M132, operation); 4-66, Fig 4-45 (Tail Fuze M905); 4-69, Fig 4-47 (Tail Fuze M906); 4-73, Fig 4-49 (Mechanical Time Nose Fuze AN-M146A1); 4-75, Fig 4-50 (Mechanical Time Nose Fuze AN-M146A1); 4-79, Fig 4-53 (Mechanical Time Nose Fuze M155A1); 4-85, Fig 4-56 [Proximity (VT) Nose Fuzes]; 4-89, Fig 4-57 (Proximity Nose Fuze M166); 4-92, Fig 4-58 (Hydrostatic Tail Fuze AN-MK230); 4-93, Fig 4-59 (Hydrostatic Tail Fuze AN-MK230, comparison of booster); 4-96 to 4-107 [Miscellaneous Fuzes for specialized applications, which include Fuze FMU-7A/B, Fuze M129 (p 4-98, Fig 4-62), Fuze M130A1 (p 4-102, Fig 4-64) and Fuze M131A1 (p 4-106, Fig 4-66)]; 5-3 to 5-7 [Adapter-boosters, which include: M102A1 (p 5-1, Fig 5-1), M115A1 (p 5-3, Fig 5-2), M117 (p 5-4, Fig 5-3), M126A1 (T45E1) (p 5-5, Fig 5-4), T46E4 (p 5-6, Fig 5-5) and T59 (p 5-7, Fig 5-6)]; 5-8 to 5-9 [Auxiliary Boosters MK1Mod0 (p 5-8, Fig 5-7) and MK4Mod0 (p 5-9, Fig 5-8)]; 5-9 to 5-12 [Primer-Detonators: M14 (p 5-10, Fig 5-9) and M16 (p 5-11, Fig 5-10)]; 5-13 [Delay Elements: T5E3 & T6E4 (Fig 5-11) and M9 (p 5-13)]; 5-13 to 5-20 [Burstors: AN-M12 (p 5-14, Fig 5-13); AN-M13 (p 5-15, Fig 5-13), AN-M18 (p 5-16, Fig 5-14), AN-M20 (p 5-17, Fig 5-15), C8R1 (p 5-18, Fig 5-16), M31 (p 5-19, Fig 5-17) and M32 (p 5-20, Fig 5-18)]; 5-20 to 5-25 [Igniters: AN-M9 (p 5-21, Fig 5-19), WP or Na M15 (p 5-22, Fig 5-20), WP or Na AN-M16 (p 5-24, Fig 5-21) and WP M23 (p 5-25, Fig 5-22)]; 5-25 to 5-30 (Signal Cartridges and Their Initiators); 5-30 to 5-32 (Spotting Charges and Their Igniters); 5-33 to 5-49 and 5-51 to 5-57 (Non-explosive components of bombs); 5-50, Fig 5-43 (Initiators FMU-7/B and FMU-7A/B) 51b) Anon, "Grenades, Hand and Rifle",

TM 9-1330-200 and NAVORD OP 3833

(1966), p 1-1 (Scope); 1-1 to 1-7 (General); 1-7 to 1-10 (Definitions); 2-1 to 2-9 (Hand Grenades, Fragmentation: MK2, M26-Series (except M26A2) with Fuze M204A; M26A2 with Fuze M217); 2-9 to 2-11 (Hand Grenade, Illuminating: MK1 with Fuze); 2-11 to 2-25 (Hand Grenades, Chemical - various types); 2-25 to 2-28 (Hand Grenades, Practice and Training); 2-29 to 2-30 (Hand Grenades, Offensive); 3-1 to 3-5 (Rifle Grenades, Antitank); 3-5 to 3-11 (Rifle Grenades, Smoke); 3-11 to 3-12 (Rifle Grenades, Practice); 3-12 to 3-18 (Grenade Projection Adapters); 3-18 (Rifle Grenade Cartridge); 4-1 (TNT Demolition Charge); 4-2 (8-second Delay Detonator); 4-3 (Firecracker M80); 4-3 (Simulator Hand Grenade); 4-4 (Grenade Launchers); 4-5 (Rifle Grenade Sights); 5-1 to 5-2 (Destruction of grenades to prevent enemy use) 51c) Anon, "Military Pyrotechnics", **TM 9-1370-200 / TO 11A10-1-1** (1966), pp 1-1 to 1-12 (Introduction); 2-1 to 2-7 (Photoflash bombs and photoflash cartridges); 3-1 to 3-57 (Aircraft flares); 3-57 to 3-65 (Fuzes shipped separately for use with parachute flares); 4-1 to 4-15 (Aircraft signals); 4-15 to 4-33 (Ground signals); 4-33 to 4-39 (Marine signals); 5-1 to 5-4 (Airburst simulators); 5-4 to 5-8 (Boobytrap simulators); 5-9 to 5-13 (Atomic explosion simulators); 5-13 to 5-15 (Ground burst simulator); 5-15 to 5-18 (Gunflash simulator); 5-18 to 5-20 (Hand grenade simulator); 5-21 (Explosive simulator); 6-1 (Fuses, warning, railroad); 6-2 to 6-4 [Ramjet engine igniters M114 (45-second) and M132 (90-second)]; 6-4 to 6-7 (Marine markers, location); 6-7 to 6-8 (Starters, fire M1 & M2); 7-1 to 7-2 (Destruction of pyrotechnics to prevent enemy use); Appendix A (Table 1 Pyrotechnic Data; Table 2 - Fuze Data) 51d) Anon, "Military Explosives", **TM 9-1300-214 / TO 11A-1-34** (1967), pp 6-1 to 6-5 (Black powder use in fuse and fuze); 6-5 (Compn of a squib: K chlorate 58, DAzDNPh 48 & NS 2%); 6-5 (Compn of a matchhead: K chlorate 30, Sb sulfide 20 & dextrin 50%); 7-14 to 7-19 (Priming compositions); 13-15 to 13-16 (Igniter comps);

13-16 to 13-18 (Delay comps); and 13-18 to 13-19 (Simulator comps)

52) Anon, "Artillery Ammunition", Dept of the Army Technical Manual **TM 9-1300-203** (1967), pp 1-10 to 1-11, Figs 1-5 & 1-6 (Explosive train); 1-39 (Fuze, definition); 1-39 to 1-44 (Primer, definition, classification and brief description of various types used in guns and howitzers); 2-88 to 2-89 & Fig 2-57 & 2-129, Fig 2-85 (Electric & percussion primer Mk 15 and Mod 2); 2-89, Fig 2-58 (Percussion primer M82); 2-89 & p 2-128, Fig 2-84 (Percussion primer Mk2A4); 5-1 to 5-2 (Fuzes, classification); 5-2 to 5-5 & Table 5-1 (Detonators, M17, 18, 19A2, 22, 23, 24, 29, 30, 30A1, 42, 44, 47, 48, 49, 50, 63 & 80 and MK37); 5-6 to 5-8, Figs 5-1, 5-2 & 5-3 (Cartridge/Projectile - Fuze Combination Chart); 5-12 to 5-53 [*Point-Detonating (PD) Fuzes*: M8 (Fig 5-6), M9 (Fig 5-7), M48A3 & M48A2, M51A5, 0.05-sec delay (Fig 5-8), M52A2 (Fig 5-9), M53A1 (Fig 5-10), M56 (Fig 5-11), M57 (Fig 5-12), M74 (Fig 5-13), M78 (concrete piercing), M78A1 (concrete-piercing, 0.025-sec delay) (Fig 5-14), M82, M82A1 (Fig 5-15), M89, M503A2, M503A1 (Fig 5-16), M507, M508 (Fig 5-17), M519 (T319) (Fig 5-18), M521 (T247) (Fig 5-19), M524A1 to M524A4, M524A5 (Figs 5-20, 5-21 & 5-22), M525A1 & M525 (Figs 5-23 & 5-24); M526A1 (Figs 5-24 & 5-27); M527A1 (Figs 5-23 & 5-29); M535 (T177E3), M557, 0.05-sec delay (Fig 5-31), M572 (XM572), XM593 (Figs 5-32 & 5-33), XM593E1, Mk27 (Navy) (Fig 5-34) and T234E2, self-destroying (Fig 5-35)]; 5-54 to 5-57 [*Point, Initiating (PI) Fuzes*: M90A1 (Fig 5-36), M509 (base detonating) (Fig 5-37), M530A1 or M530 (base detonating) (Fig 5-38), XM539E4 (base detonating) and XM22E2 (control-power supply)]; 5-57 to 5-71 [*Mechanical Time (MT) Fuzes*: M43A4 (Fig 5-39), M61A2, M61A1 (Fig 5-40), M61, M67A3 (Fig 5-41), M562 (Fig 5-42), XM563E1, (Fig 5-44), M565 (Fig 5-45), XM592 (Fig 5-46) and XM711 (Fig 47)]-5-71 to 5-93 [*Mechanical Time and Super-quick (MTSQ) Fuzes*: M500A1 (Fig 5-48), M500, M501A1 (Fig 5-49), M501, M502A1 (Fig 5-50), M502, M506 (T176E3) (Fig 5-51),

M518A1, M518 (T286E1), M520A1 (Fig 5-52), M520, M548 (Figs 5-53, 5-54, 5-55, 5-56 & 5-57) and M564 (Figs 5-58, 5-59 & 5-60); 5-93 to 5-96 (*Time (T) Fuzes*: M65A (fixed) (Fig 5-61) and M84 (Fig 5-62)] 5-96 to 5-102 [*Time and Superquick (TSQ) Fuzes*: M54 (Fig 5-63), M55A3 (Fig 5-64) and M77 (Fig 5-65)]; 5-102 to 5-108 [*Base Detonating (BD) Fuzes*: M58 (practice), M62A2 (Fig 5-66), M68A1, M68, M91A1 (Fig 5-67), M534A1 and M578 (Fig 5-68)]; 5-108 to 5-126 [*Proximity (VT) Fuzes*: M504A2, M504A1 (T75E7), M504 (T175E6), M513 (T226) M513B1 (T226B1), M513A1 (T226E2) (Figs 5-73 & 5-74), M513A2 (T226E3), M514A1 (T227E2), M515 (T225) (Fig 5-75), M516A1 (T73E10), M516B2 (T73E14), M561B1 (T73E13), M516 (T73E12), M517 (T178E3) (Fig 5-76) and M532 (for mortar) (Fig 5-77)]; 5-126 to 5-130 (*Dummy and Inert Fuzes*: M44A2, M79, M80, M48, M51, M59 & M73); 5-131 to 5-138 (*Boosters*: M21A4, M21A2, M22, M24, M24B1, M25, M124, M125A1 and M125)

53) Anon, "Explosives and Demolitions", Dept of the Army Field Manual **FM5-25** (1967), 22-3 (Time blasting fuses); 23-5 (Detonating cords); 25-31 (Blasting cap, electric and nonelectric); 31-2 (Blasting machine); 34 (M10 Universal HE destructor); 34 & Fig 28, p 35 (M19 Explosive Destructor); 34-5 & Fig 29, p 36 (M1 Concussion detonator); 35 & Fig 30, p 37 (M1A1 15-Sec Delay friction detonator); 35 & Fig 31, p 37 [M1A2 (M1E1) 15-Sec Delay percussion detonator]; 35-6 & Fig 32, p 38 [M2A1 (M2E1) 8-Sec Delay percussion detonator]; 36 & Fig 33, p 40 (M2 8-Sec Delay friction detonator); 36, 38-9 & Fig 34, p 40 (M1 Delay firing device); 40-2 & Fig 35 (M1A1 Pressure firing device); 42-3 & Fig 36 (M1 Pull firing device); 43 & Fig 37, p 44 (M3 Pull-release firing device); 43-5 & Fig 38 (M5 Pressure-release firing device); 45 & Fig 39, p 46 (M2 Weatherproof lighter); 45 & Fig 40, p 46 (M60 Weatherproof lighter); 48-52 (Blasting kits); 55 and Figs 49, 50 & 51 (Nonelectric priming of demolition blocks); 55 & Fig 52 (Nonelectric priming of plastic explosives C3 & C4); 55, 57-8 and Figs 53 & 54 (Nonelectric priming of dynamites); 58 & Fig 55 (Nonelectric priming of AN and Nitramon charges); 58-9 & Fig 56 (Nonelectric priming of M2A3, M2A4 & M3 shaped charges); 59 & Fig 57 (Nonelectric priming of bangalore torpedoes); 59 & Fig 58, p 60 (Nonelectric priming of M118 demolition charge, commonly known as "sheet explosive"); 63-5 & Fig 64 (Electric priming of demolition blocks); 65 & Fig 66 (Electric priming of plastic explosives C3 & C4); 65 and Figs 67 & 68 (Electric priming of Dynamite); 65 & Fig 69, p 67 (Electric priming of AN & Nitramon charges); 65 & Fig 70, p 67 (Electric priming of M2A3, M2A4 & M3 shaped charges); 65 & Fig 71, p 68 (Electric priming of bangalore torpedo); 65 & Fig 72, p 68 (Electric priming of M118 demolition charge, known as "sheet explosive"); 71 & Table VII [Premature detonation of electric blasting caps by induced radio frequency (RF) current]; 71 (Premature detonation by lightning); 71-9 (Detonating cord priming)

54) Anon, "Engineering Design Handbook. Military Pyrotechnics Series. Part One. Theory and Application", US Army Materiel Command Pamphlet **AMCP 706-185** (1967), pp 5-29 to 5-37 (Pyrotechnic delays); 5-37 to 5-40 (Ignition compns for gasless delay elements); 5-45 (Initiators, first fires, and starters); 5-45 to 5-46 (Prime ignition); 5-46 to 5-51 (Characteristics of ideal igniter, first fire, and starter compositions); 6-33, Fig 6-19 (Armor-piercing tracer with igniter)

55) H. Bullock, Curator, Picatinny Arsenal Museum, private communication (1968)

56) John F.W. Pflueger, formerly at Picatinny Arsenal, now at Letterkenny Army Depot, Chambersburg, Pa (1968)

57) H. Ellern, "Military and Civilian Pyrotechnics", ChemPubgCo, NY (1968) (Superseding Ref 44a)

58) Anon, "Engineering Design Handbooks", compiled at the Army Research Office-Durham, Box CM, Duke Station, Durham, North Carolina 27706: No 179 - "Explosive Trains"; 210 - "Fuzes, General and Mechanical"; 211(C) - "Fuzes, Proximity, Electrical", Part 1; 212(S) - "Fuzes, Proximity, Electrical", Part 2; 213(S) - "Fuzes, Proximity,

Electrical", Part 3; 214(S) - "Fuzes, Proximity, Electrical", Part 4; and 215(C) - "Fuzes, Proximity, Electrical", Part 5. They were not used as sources of information

**Section 7, Part B
ADDITIONAL REFERENCES**

(Patents, Technical Reports and Articles in Journals on Detonators, Primers, Fuses, Fuzes and Igniters) (Which were not included in Vols 1, 2 & 3 of Encyclopedia)

Ad 1) M. Novak, SS **3**, 89-91 (1908) & CA **2**, 9991 (1908) (Zünder für Landminen) Ad 1a) E. Neumann, SS **5**, 87, 107, 130, 148 & 168 (1910) (Die Zündschnüre und ihre Fertigung) Ad 2) Dr. Utescher, SS **9**, 100, 123, 146 & 161 (1914) (Geschichtliche Entwicklung der Zündung in Waffen und Geschossen) Ad 3) A. Stettbacher, SS **9**, 341, 355, 381 & 391 (1914) (Altes und Neues über Initialzündstoffe) Ad 4) A. Stettbacher, SS **10**, 16-19 (1915) (Verfahren und Vorschläge zum Detonieren von Sprengladungen) Ad 5) A. Stähler, GerP **290999** (1915) & CA **11**, 1549 (1917) (Priming expls contg Ethylenediaminochlorate either per se, or in mixts with MF) Ad 6) W.H. Buell, USP **1174669** (1916) & CA **10**, 1435 (1916) (Priming chge prepd by mixing LA 6, NC 11 & Na or K azide 3 parts. An alkaline residue of Na or K oxide formed on ignition prevents the erosion of gun barrel) Ad 7) W.H. Buell, USP **1184316** (1916) & CA **10**, 1791 (1916) (Priming chge: K chlorate 30, Sb sulfide 35 & Na azide 35%) Ad 8) A. Stettbacher, SS **11**, 1, 34 & 147 (1916) (Prepn & props of Ag acetylde, Ag azide, diazobenzeneperchlorate, etc) Ad 9) P. Wolf, SS **11**, 4-7 (1916) (Mixts of LA, nitrodiazobenzeneperchlorate and nitrogen sulfide as replacement for MF in initiating compns) Ad 10) W. Arthur, IEC **9**, 392-95 (1917) & CA **11**, 1751 (1917) (Review of mixts used in percussion caps and primers and their prepn) Ad 11) G.B. Taylor, CanadChemJ **2**, 7-8 (1918) (High-expl primers; historical review) Ad 12) H.E. Ellsworth & J.K. Brandon, The Hercules Mixer (Journal) **4**, 123-26 & 147-48 (1922); CA **16**, 2225 (1922) (Description of manuf of various safety fuses) Ad 13)

L. Wöhler, Angew Chem **35**, 545-49 (1922) & CA **17**, 1144 (1923) (Historical review of initiating compns from the discovery of MF to cyanuric triazide) Ad 14) H.T. Peck, USP **1416121** (1922) & CA **16**, 2409 (1922) (Primer compn for small arms ammo: Trinitroresorcinol 15, Pb thiocyanate 20, K chlorate 50 & Pb styphnate 15%); Ibid, USP **1416122** (1922) (Similar to above but Diplumbic di-trinitroresorcinol is used instead of Trinitroresorcinol); Ibid, USP **1416123** (1922) (Similar to above except that MF is used in lieu of Pb nitroresorcinol compds) Ad 15) W. Eschbach, BritP **276962** (1926) & CA **22**, 2467 (1928) (Igniting compn consisting of powdered Al 40, Mg 20 & ferrosulfuric oxide 40% is forced into a cap; it can be ignited electrically or by fuse) Ad 16) C.A. Woodbury, USP **1783372** (1931) (Loading of detonator tube) Ad 17) Hercules Powder Co, BritP **383650** (1931) & CA **27**, 5982 (1933) (A practically gasless timing train compn in delay-action fuzes or detonators is composed of an oxidizing agent such as BaO₂, KClO₃, KMnO₄, Pb₃O₄ and fuel consisting of an element of the right hand column of Group 6, such as S, Se or Te) Ad 18) W. Eschbach, GerP **572639** (1933) & CA **27**, 4402 (1933) (Mixts in the propn 1:1 of reduced Fe/KMnO₄, Sb/KMnO₄ or C-Mg/CaO₂ give, on being electrically ignited, very hot flames and no gas) Ad 19) S.B. Large, USP's **1928205**, **1928206**, **1928207** & **1928208** (1933) and CanadP's **341781** & **341782** (1934); CA **28**, 5242 (1934) (Various detonators and compositions for them) Ad 20) H.B. Alexander, USP **1989729** (1934) & CA **29**, 1988 (1935) (Igniter compns contg equal parts of Se/Pb or Se/Sn) Ad 21) J.H. Hammond Jr, USP **2015670** (1935) & CA **29**, 8335 (1935) (Photoelectric detonator used for controlling the detonation of torpedoes by means of a searchlight) Ad 21a) E.T. Lednum, USP **2024586** (1935) (Initiator) Ad 22) R. & M. Anker, FrP **783249** (1935) & CA **29**, 8335 (1935) (A slow combustion fuse compn is prepd by mixing with alcohol to form a thick paste: K nitrate 5, pulverized sulfur 4 and charcoal 3.5 parts; after thorough blending the mass is dried) Ad 23) L.A. Burrows et al, USP **2105635**

- (1935) (Various ignition compns for electric detonators) Ad 24) T. Olpinski, *Widomosci Techniczne Uzbrojenia* **1935**, No 27, pp 44-72 and *MAF* **16**, 911-25 (1937) (Safety devices in artillery fuzes) Ad 25) J. and J. Doerfer, *USP* **2035597** (1936) & *CA* **30**, 3650 (1936) (Priming mixt for small arms cartridges: KClO_3 48-53.5, $\text{K}_4\text{Fe}(\text{CN})_6$ 33.3-35 & glass 13.3-16%) Ad 26) J.E. Burns, *USP* **2038097** (1936) & *CA* **30**, 4010 (1936) (Priming compn: LStyphnate 27, Tetracene 3, Zr 7, Pb nitrate 40, Sb sulfide 14 & Pb thiocyanate 9%) Ad 27) Imperial-ChemIndLtd, *FrP* **796833** (1936) & *CA* **30**, 6200 (1936) [Mixts for electric detonators: 1) Pb_3O_4 87 & Fe-Si 13% 2) Pb chromate 90 & Ca silicide 10% 3) K permanganate 60 & Zn 40% or 4) Ba peroxide 94 & Mg 6%. The fusehead is composed of a mixt of finely divided Zr and finely divided Pb 2-nitroresorcinate] Ad 28) A. Weale, *USP* **2065929** (1936) & *CA* **31**, 1212 (1937) [Priming compns for percussion caps consists of two layers: 1) LA + Ba nitrate + small amt of Tetracene and 2) Ca silicide + Ba nitrate] Ad 29) F.R. Seavey, *USP* **2068516** (1937) & *CA* **31**, 2010 (1937) [In a primer provided with an anvil there is a layer of a relatively small quantity of a sensitive priming expl (such as compns contg MF or LA) and a layer of less sensitive expl consisting of an oxidizer (such as Ba nitrate) and fuel (such as Pb thiocyanate, ferrosilicon, or cellulose acetate). Such primers produce hot flame] Ad 30) J. Fleming & W.S. Dennler, *BritP* **471433** (1937) & *CA* **32**, 1456 (1938) (Manuf of safety fuses) Ad 31) L. Rubinstein & W. Taylor, *BritP* **471907** & **473146** (1937); *CA* **32**, 1934-36 (1938) (Fusehead of an electric detonator) Ad 32) E. Ravelli, *Rivista di Artiglieria e Genio* **1937** (Jan-Feb), p 139 (Studio sulla meccanica delle spolette instantanee nei progetti di caduta) and *MAF* **17**, 653-81 (1938) (*Étude sur la mécanique des fusées instantanées dans les bombs*) Ad 33) L.A. Burrows, *USP* **2086533** (1937) (Ignition compns for electric detonators contg salts of N,N-dichlorazodicarbonamidine) Ad 34) G.C. Hale & W.H. Rinckenbach, *USP* **2116514** (1938) & *CA* **32**, 5214 (1938) (Primers contg normal Pb dinitroresorcinate) Ad 34a) A. Stettbacher, *Nitrocellulose* **1938**, 75, 100 & 138 (Chem ignition and its application) Ad 35) W. Brün, *USP* **2116878** (1938) & *CA* **32**, 5214 (1938) (Priming mixts contg Pb nitratohypophosphite together with LStyphnate, basic LSt, LA, DAzDNPh, MF, Tetrazole (and its derivs), and the salts of di- and trinitrobenzoic, -phthalic and salicylic acids) Ad 36) G.C. Hale & W.H. Rinckenbach, *USP* **2124568** (1938) (Primer consisting of normal Pb dinitroresorcinate 75 & BkPdr 25%); *Ibid*, **2124569** (1938) (Primer with normal Pb dinitroresorcinate 75 & Tetracene 25%); *Ibid*, **2124570** (Primer with normal Pb dinitroresorcinate & NC); *CA* **32**, 7268 (1938) Ad 37) V.N. Poddubnyi, *Tekhnika i Voöruzheniye* **7**, No 8, pp 73-7 (1938) & *CA* **34**, 6449 (1940) (Non-corrosive priming mixts consisting of LStyphnate & aminoguanidine) Ad 38) W.A. Lazier, *USP* **2157669** (1939) & *CA* **33**, 6600 (1939) (Priming mixt contg besides usual fuel & oxidizer some chromate of a heavy metal, such as of Cu or Ag, which is supposed to act as a catalyst) Ad 39) L.A. Burrows, *USP* **2173271** (1939) (Ignition compns contg Ca hypophosphite) Ad 40) L.A. Burrows & W.F. Filbert, *USP* **2175249** (1939) (Ignition compns contg double salts of 4,6-Dinitro-o-cresol) Ad 41) L.A. Burrows & W.E. Lawson, *USP* **2175250** (1939) (Electric detonators using combustible element comprising of Pb salts of dinitrophenol, mononitroresorcinol, or dinitro-o-cresol; also lead nitrate-bis basic lead dinitro-o-cresylate) Ad 41a) W. Taylor, *Chem & Ind* **58**, 1065-69 (1939) (Modern detonators) Ad 42) C. Ostaszkiwicz, *Widomosci Techniczne Uzbrojenia* **1939**, No 4 & *MAF* **19**, 181-96 (1940) (Construction and precision of functioning of mechanical time fuzes. They were invented in 1840 in Switzerland & Germany, but did not find practical application until WWI, when Germans started to use them and this was followed by France, England, Russia, Sweden, Switzerland and USA) Ad 43) S.B. Large & G.F. Rolland, *USP* **2195032** (1940) & *CA* **34**, 5284 (1940) [Electric de-

tonators contg DAzDNPh (as igniter), HNMnt (as "safety priming" compd) and Tetryl (as base charge)] Ad 44) Ph. Naoum, GerP **698403** (1940) & CA **35**, 6796 (1941) (Detonator contg Hexamethylenetriperoxidodiamine) Ad 45) L.A. Burrows & C.A. Woodbury, USP **2205081** (1940) (Description of a collapsible tube method for depositing ignition and explosive chges in electric blasting devices) Ad 46) L.B. Woodworth, USP **2226988** (1940) & CA **35**, 2722 (1941) (An electric detonator of special construction) Ad 47) L.K. Ingram, BritP **528918** (1940) & CA **35**, 8300 (1941) (Fusehead for electric detonators contg iodoso- or iodoxy- azidobenzene, Zr powder, K chlorate & bonding agent) Ad 48) L.K. Ingram, USP **2241406** (1941) & CA **35**, 5318 (1941) (Fusehead for electric detonators; essentially the same as in Ref Ad 47) Ad 49) L.A. Burrows & G.A. Noddin, USP **2268372** (1941) [Ignition compns comprising mixts of NC (pyro), lead salts of nitrophenols and chlorates] Ad 50) H. Fritzsche, Nitrocellulose II, 24, 88 & 125 (1940) (Sicherheitszündschnüre - Safety fuses) Ad 51) J. McNutt & S.D. Ehrlich, USP **2292956** (1942) & CA **37**, 1041 (1943) (Priming mixt for small arms ammo contg a double salt of Pb styphnate & Pb hypophosphite together with Pb nitrate & powdered glass) Ad 52) W. & M. Jones, USP **2331007** (1943); CA - not found (Manuf of electric detonators of special design) Ad 52a) A. Stettbacher, SchweizChem-Ztg **1944**, 27-37 (11 figs) (Chemical ignition) Ad 53) L.A. Burrows & G.A. Noddin, USP **2403907** (1946) (Igniter for smoke pots) Ad 53a) H. Selvige, Electronics **19**, No 2, 104 (1946) (Proximity fuzes) Ad 54) J.C. Frazer & O.G. Bennett, USP **2434067** (1946) & CA **42**, 7046 (1948) [Short delay, gasless, fuze elements suitable for military purposes obtd from stoichiometric mixt of powdered sulfur and finely divided Ni (prepd by evaporating Hg from Ni amalgam). As the mixt burns with extreme rapidity, it is desirable, in some cases, to slow it down. This may be done by incorporating some diatomaceous earth] Ad 55) L.F. Audrieth, USP **2410801** (1946) & CA **41**, 866 (1946) [Priming mixts, or fuel trains for expl shell: a) K chlorate 51, Sb sulfide 34, polythiocyanogen 10 & LA 5% b) K chlorate 64, Sb sulfide 21, polythiocyanogen 10 & LA 5%] Ad 56) J. Gillies, BritP **575506** (1946) & CA **41**, 6724 (1947) (Priming compn which practically does not evolve any gases, consists of Ca silicide & Mn dioxide with or w/o CuO) Ad 57) D.T. Jones & L. Rubenstein, BritP **582976** (1946) & CA **41**, 2246 (1947) (Priming mixts contg as principal ingredients basic lead salts of 4,6-dinitroresorcinol) Ad 58) H.H. Holmes & W.E. Lawson, USP **2414465** (1947) & CA **41**, 2578 (1947) (Fuse burning at the rate of ca 46 sec/yd is obtd by replacing part or all the charcoal of fuse compn burning at 75 sec/yd, with a special type of carbon black produced by incomplete combustion of natural gas or of other gaseous fuel) Ad 59) C.J. Bain & L.R. Carl, USP **2415806** (1947) & CA **41**, 2901 (1947) (Detonator for use in military ammo contg as a main chge an aromatic nitrocompd, as a priming chge LA and as an igniting chge mixt of K chlorate, Sb sulfide & LA) Ad 60) D.A. Pearsall, USP **2416639** (1947) & CA **41**, 2900 (1947) (Slow burning fuse consists of polyvinyl alcohol 5 to 55, Fe silicide 1 to 15, oxidizing agent 10 to 75, woodflour 1 to 25, sulfur 5 to 50 & graphite 0.5 to 10 parts by wt) Ad 61) L.A. Burrows et al, USP **2420661** (1947) (Ignition friction device) Ad 62) C.A. Martin, USP **2423837** (1947) & CA **41**, 7120 (1947) (Detonator consisting of a priming mixt which is separated from a base chge by a thin foil of a low melting alloy, such as Wood's metal. It is assumed that foil melts on firing and incandescent droplets disseminate thruout the main chge, thus causing more uniform ignition) Ad 62a) A.R. Ubbelohde, TrRoySoc **241A**, 280-86 (1948) (Mechanical and thermal processes of initiation) Ad 63) J.C. Frazer & O.G. Bennett, USP **2440579** (1948) & CA **42**, 5230 (1948) [Gasless delay fuze elements consisting of finely divided Ni (prepd by volatilizing Hg amalgam) and an oxidizing agent, such as Mn dioxide or alkali nitrate, chlorate or perchlorate] Ad 64) G.C. Hale & D. Hart, USP **2461544** (1949) & CA **43**, 3620 (1949) [Gasless delay powder train compns for use in fuzes consist

of finely subdivided metals mixed with metalloids (both to pass 250-mesh screen):

- a) Zr 75 & S 25% b) Ti 60 & Te 40%
c) Ti 80 & S 20% and d) Mn 70 & S 30%.

The burning time of a powder column 2 inches long by 0.22 inches diameter is less than 1 sec for mixts a) & b), 7 sec for c) and 4 sec for d)]

Ad 65) G.C. Hale & D. Hart, USP **2467334** (1949) & CA **43**, 4856 (1949) (Gasless delay powder compn consisting of finely divided Mn-Ti alloy 90 & S 10%, both passing thru 250-mesh screen. Other mixts proposed: Fe-V alloy with S and Ba-Si with S or Te)
Ad 66) G.C. Hale & D. Hart, USP **2468061** (1949) & CA **43**, 5189 (1949) (Gasless fuze powders easy to ignite because they contain some red phosphorus, eg: Ba chromate 96 & P 4%. Other oxidizers, such as Ag oxide or chromate, Ba dioxide, Fe oxides, Ca chromate, etc may also be used in conjunction with P)
Ad 67) E. Patterson, USP **2478501** (1949) & CA **43**, 9450 (1949) (Fast-burning delay compns for fuzes consist of finely divided Zr and Pb₃O₄ mixed with small amt of collodion, compressed into pellets and dried. Burning rates can be varied from 25 to 50 milliseconds per cm length)
Ad 68) G.C. Hale & D. Hart, USP **2478918** (1949) & CA **44**, 840 (1950) (A gasless delay compn, such as finely divided mixt of Ag oxide 50, Fe 25 & red P 25%)
Ad 69) J. Kenner, Nature **163**, 291-92 (1949) & CA **43**, 3617 (1949) (Outline of theory of detonators)
Ad 70) E.R. Rechel & T. Stevenson, USP Appl **579481** (1949) & CA **44**, 11098 (1950) [Use of a non-expl primer, such as consisting of a mixt of finely divided red P 10 to 35% and a finely divided oxidizer (such as Pb dioxide or Ba or Sr nitrate) 90 to 65% eliminates undesirable high pressures within cartridge cases on ignition of smokeless proplnts. Such priming mixts may contain also binders (gum arabic, gelatin or glue), abrasives (powdered glass or SiC), sulfides (of Pb or Sb) and metallic fuels (Zr powder)]
Ad 71) T. Matagi, JapanP **179428** (1949) & CA **45**, 9863 (1951) (Slow-burning fuze contg Pb₃O₄ 70 & silicon 30%)
Ad 72) H. Ficherouille & A. Kovache, MP **31**, 7-27 (1949) & CA **46**, 11686 (1952) (Prepn & props of compns

used in primers and detonators) Ad 73) A.R. Ubbelohde, Research (London) **3**, 207-12 (1950), "Activation Processes in the Sensitiveness of Explosives" (For primary expls, the process which "triggers" energy release may involve thermal or tribochemical activation of the molecules)
Ad 74) J.T. Power, USP **2495868** (1950) & CA **44**, 7540 (1950) (Nitrated dextrose polymers as base charges in detonators)
Ad 75) H. Zenftman, USP **2497387** (1950) & CA **44**, 5594 (1950) (A non-detonating fuze which contains K nitrate 15 to 50, Pb₂O₄ 60 to 30 & Si 10 to 40%)
Ad 76) W.A. Filbert, USP **2511669** (1950) & CA **44**, 9149 (1950) (Ignition compns characterized by short delays betw initiation and full flame development consist of BkPdr mixed with 5-10% of explosive Pb compds, such as double salt of Pb nitrate and dibasic Pb salt of 4,6-dinitro-o-cresol)
Ad 77) H. Zenftman, USP **2513391** (1950) & CA **44**, 9152 (1950) (A waterproof gasless fuze is prepd by incorporating Pb₃O₄ & Si into a plastic binder, extruding the mixt at ca 120°, and covering with cotton yarn, bitumen and gutta-percha)
Ad 78) M. Dutour, MAF **24**, 577-84 (1950) & CA **45**, 8772 (1951) (Detonation velocities of "cordeaux détonants")
Ad 79) A. LeRoux, MP **32**, 205-07 (1950) (Resistance to high temps of various ammunition items, including detonators)
Ad 79a) L. Médard MP **33**, 339 (1951) (Briska detonator)
Ad 80) V. Hajek & J. Hajek, Research **4**, 186-91 (1951) (Devices designed to cause an explosion after a fixed delay time may be mechanical, electrical or chemical. Amongst the mechanical delaying devices may be mentioned the clockwork mechanisms, while the electrical devices include condensers with adequate capacitance delaying the condenser discharge. Some chemical devices are based on the dissolution of a capsule made of a plastic (such as celluloid) and contg the detonator. For example, when concd sulfuric acid comes in contact with K chlorate + NC or K chlorate + MF, instantaneous explns take place. In another type of chemical device, the reaction liberates heat which brings the temp of detonator chge above its expln point.

For example, when concd sulfuric acid is brought in contact with a mixt of KMnO_4 and some org substances, such as glycerin or sugar, the temp is raised to inflammation point and the detonator fires the main chge. The same happens when concd hydrogen peroxide is added to $\text{Al} + \text{C}$ or to thorium or when fuming nitric acid is added to triethylamine

Many chemical ignition devices have been used in sabotage devices and many of them were described by Stettbacher (Ref 18, pp 130-32; Ref 21, pp 164-66 and Addnl Refs Ad 34a & Ad 52a). Ellern (Ref 57, pp 48-52) describes some chemical reactions which can be used in sabotage devices and on pp 216-23 are listed several fire starting and fire setting devices, some of which can be used as sabotage incendiaries

As handling of the above mentioned chemical devices is dangerous and as it is very difficult with them to regulate the delays, Hajeks proposed new devices in which the delays depend on the concentration of the mixture ingredients in water. The reactions are based on the reduction of aromatic nitrocompds such as PA, TNT, Tetryl, etc into amines which give rise to several super-imposed reactions, such as formation of diazocompds or endothermic expls

For example, Al reacts with w in presence of a hydrogen acceptor (such as PA), as follows:

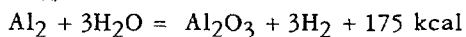

$\text{HO.C}_6\text{H}_2(\text{NO}_2)_3 + 3\text{H}_2 = \text{HO.C}_6\text{H}_2(\text{NO}_2)_2.\text{NH}_2$ (6-Amino-2,4-dinitrophenol). (An emulsifier, such as Emulhor is added to facilitate wetting of Al particles)

If AN is present it may be reduced to nitrite by hydrogen of the above reaction and nitrite will form 1-hydroxy-2,4-dinitro-6-diazoammonium hydroxide according to the reaction:

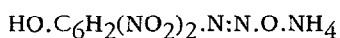

The reduction of AN is facilitated by the presence of certain catalysts such as Fe , Cu , etc and it is assumed that if perchlorate ion is present, the above diazoammonium hydroxide

is transformed into diazoammonium perchlorate, $\text{HO.C}_6\text{H}_2(\text{NO}_2)_2.\text{N:N.ClO}_4$ and this may decompose forming a chlorate

In the reactions involving Al , the presence of ferric oxide has a catalytic effect because it reacts with hydrogen liberated by action of Al on water:

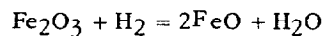

and resulting ferrous oxide reacts with another portion of Al , as follows:

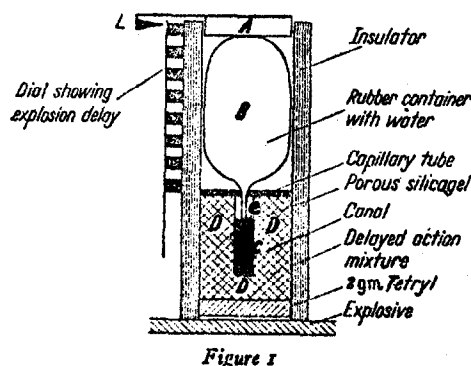
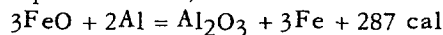

Figure 1

A schematic arrangement of latest Hajek's device is shown in Fig I. It consists of a double-walled cylindrical vessel, 15-mm ID, insulated with glass wool and contg 20 g of $\text{Al} + \text{Fe}_2\text{O}_3 + \text{emulsifier}$, but no water (D). At the bottom of the vessel are placed 2 to 4 g of Tetryl (which can be replaced with MF or LA). In the middle of the vessel is a 5-mm canal, c, filled with porous silica gel. When the top part, A, of the device forces the water stored in the container, B, to flow thru the capillary, e, in the canal, c, and to the vessel contg D, the reactions described above would take place. The needle, L, sliding along dial indicates the delay. At the end of delay period ignition or explosion takes place and this would initiate the chge of expl located under Tetryl (See Fig). Delays depend on the amt of w used and can be from 3 to 210 minutes] Ad 80a) R. Marsh, Ordn 36, 75-81 (1951) (Russian Ordnance as judged by weapons captured during the Korean War) Ad 81) T. Sakamara, JapanP 147 (1951) & CA 46, 11690 (1952)

(Electric detonators contg as principal ingredients Pb or Ag dinitroresorcinate, Eg: Pb dinitroresorcinate 55, K perchlorate 20, sulfur 10, Al powder 10 & collodion cotton in soln 5%) Ad 81a) M. Berger, MAF **25**, 77-89 (1951) (Fusées de proximité) (Proximity fuzes) Ad 82) A.M. Ball, Ordn **37**, 438-40 (1952) (Igniter compn for solid rocket proplnts. It consists of a large proppn of BkPdr and a small proppn of a flash mixt) Ad 83) J.B. Chalmers & F.H.J. McCaffrey, USP **2587694** (1952) & CA **48**, 6700 (1954) [A waterproof connector transmitting ignition from igniter cord to safety fuse consists of a metallic tube arranged to be crimped to a safety fuse at one end and to receive an igniter cord thru a slot in the other end. The receiving end of collector is charged with mixt of NC 87.5, Sb₂S₃ 4.0 & PbO₂ 8.5%, while the transmitting end contains PbO₂ 82.8, Si 9.2 & NC 80%] Ad 84) H. Zenftman & J.E. Forlin, USP **2590060** (1952) & CA **48**, 6700 (1954) [Fuse compn employing thermoplastic binder can be continuously extruded provided a small amt of a special antihardening agent (such as citric acid, K acid oxalate or Butyl Cello-solve) is incorporated in mixt, such as NC (colloided), DBuPh, Pb₃O₄, K nitrate & Si] Ad 85) S.J. Magram & J.J. Blissel, USP **2640770** (1953) & CA **47**, 7780 (1953) (Igniter compns for incendiary ammo: Fe₃O₄ 55-70 & Zr or Ti powder 45-30%) Ad 86) S. Kinoshita & T. Sakamaki, JapanP **2498** (1953) & CA **48**, 6700 (1954) [Detonators for electric blasting contg: a) Sb or Cu powder 80, Pb mononitroresorcinate 10 & K chlorate 10% or b) Cu powder 90 & Pb mononitroresorcinate with binding agent 10%] Ad 86) S. Nauckhoff, Explosivst **1953**, 29-34 (Investigation of process of combustion of fuses) Ad 87) L. Rubenstein, USP **2653863** (1953) & CA **48**, 2376 (1954) [Initiating compn was prep'd by simultaneous adding at a constant rate over 9 mins, two 125-ml solns to 800-ml of 0.02% aqueous dextrin soln while the temp was maintained at 70°. The 1st soln consisted of 7.8 g of Na azide & 3 g of 2,4-dinitroresorcinol that had been treated with aq soln of 1.12 g NaOH & 0.02 g Rochelle salt; the 2nd soln contained

25 g of Pb nitrate. The mixt of two solns was cooled, filtered and the red granular ppt (which contained both Pb azide and Pb dinitroresorcinate) was dried by warm air] Ad 87a) J.G. Tschinkel, USP **2637161** (1953) & CA **47**, 7762 (1953) (Spontaneous ignition of a rocket motor powered with a liq oxidizer-fuel system, ca 5% of a fuel which reacts spontaneously with oxidizer, is added to the main fuel chge. The additive must have a higher density and not mix with the bulk fuel. Therefore, when the rocket is fired in a vertical position, the additive enters the combustion chamber first and spontaneous ignition occurs) Ad 88) S. Hirose & K. Homma, JapanP **6748** (1954) & CA **50**, 9022 (1956) [Ignition ball for electric detonator prep'd by suspending Pb thiocyanate & K chlorate in carbon tetrachloride (or other non-combustible solvents) contg raw rubber] Ad 89) U. Günther & Inventa AG für Forschung und Patentverwertung, Zürich, USP **2687667** (1954) & Ordn **39**, 608 (1955) (Primer for igniter compns) Ad 90) M.G. Clay, USP **2707918** (1955); CA - not found; (Ordnance, **40**, 302 (1955) (This invention relates to Fuzes which form the front end of an HE or other military shell. They activate the shell after firing and when the shell reaches a certain rotational speed. Four detent pins are held in place by a circular leaf spring which extends around the outer ends of the detent pins. When the rotational speed of the shell reaches a certain value, centrifugal force causes the leaf spring to open, releasing the detent pins and thereby arming the shell) Ad 91a) G. Rove, Ordn **39**, 831-33 (1955) [Mechanical time fuzes, superquick (MTSQ) - M500A1 and M502A1 developed by the Army Ordnance Corps are described. Also is briefly described the early mechanical fuze which was invented in 1860 by Lt Tremel of Bavaria] [Note: Accdg to Ostankiewicz (Ref Ad 42), the 1st mechanical time fuze was invented in 1840 in Switzerland and Germany] Ad 91b) M. Zippermayr, Explosivst **1955**, 25-40 & CA **49**, 8601 (1955) (Initiation by gas compression & heat in various confinements is discussed for TNT, NG and German mining expls) Ad 92) W.B. Smits, USP **2708877** (1955) & Ordn,

- 40, 474(1955) (Electrical ignition device for expls using two cylindrical electrodes separated by a cylindrical insulator and a condenser is described) Ad 93) F.P. Bowden & K. Singh, *PrRySoc* **227A**, 22-37 (1955), abstracted by H. Freiwald in *Explosivst* **1956**, 66 [Irradiating sensitive expl crysts (LA, AgA, CdA, N iodide & Ag acetylide) results in all being exploded by an extreme electron stream, which is a thermal effect due to bulk heating of the crysts) Ad 94) P.E. Braid et al, *CanadJTechnol* **34**, 45-52 (1956) & *CA* **50**, 7461 (1956) (Paper describes method of preventing electrostatic chges forming on dry powder and preventing explns during hand operations in handling detonators. Kind of detonators, not specified) Ad 95) A. Stettbacher, *Explosivst* **1957**, 91 (Zum chemotermischen Vorstoss auf den Atomkern) Ad 96) T.J.M. Mulqueeny & F.R. Seavey, *USP* **2825639** (1958) & *CA* **52**, 7704 (1958) [An expl train for elec detonators & blasting caps is described having an RDX base chge, an LA initiating chge, and an ignition chge; initiating chge is placed betwn the ignition & base chges. The ignition compn consists of dry MF (40-90% thru 200-mesh sieve) 30-50% mixed with ground proplnt (100% thru 60-mesh sieve) 50-70%. The proplnt compn is: DPA 0.3-1.2, graphite 5.0 max, ether extractable compds 2.75 max % & NC (12.0-12.7%N) the balance. The av firing times in millisecs for caps charged with various mixes are: 50/50 MF/Proplnt 3.6, total 10.9; 40/60 mix 3.9 & 13.2; and 30/70 mix 5.3 & 18.0] Ad 97a) R.C. Maninger, "Initiation of PETN and RDX by Exploding Bridgewires", Paper No 9, Electric Initiator Symposium, Franklin Institute, Philadelphia, Pa, Nov 29-30, 1960 Ad 97b) M.T. Hedges, "Exploding Bridgewire Initiators", *Ibid*, Paper No 13 Ad 97c) P.B. Tweed, "Electric Detonators", *Ordn* **44**, 653-55 (1960) (Description of typical electric detonators used by the US Armed Forces) Ad 98) A. Straka & J. Hykel, *CzechP* **93934** (1960) & *CA* **55**, 12855 (1961) (Primer compn in detonators consists of DAzDNPh 66.5, K chlorate 30 & Ag azide 3.5%, mixed with 0.1-3 parts of gum arabic or dextrin in w. It is claimed that effectiveness of DAzDNPh is increased 10-fold by the addn of Ag azide) Ad 99) H. Nodding, *GerP* **1115628** (1961) & *CA* **56**, 11875 (1962) [A shock-insensitive delay compn of uniform burning rate useful for elec delayed-action fuses or detonators is prepd by mixing Boron 0.5-3, Pb₃O₄ 74.5-22 and 2PbO. - PbHPO₃ 0.5H₂O 25-75% by wt with a preferred % ratio of 1.37/45.50/53.13%. Grain-ing agents such as org polysulfides & chlorobutadiene polymers (0.5-1.5% by wt) may be added] Ad 100) Schaadt & T. Weber, *GerP* **1119743** (1961) & *CA* **57**, 2488 (1962) (Priming charge is made of a mixt of porous NC powd & NG powd, in a ratio of 2-7.5/1, inserted as a film in the priming screw, thus serving simultaneously as the screening disk for the priming screw) Ad 101) D. Hart, *USP* **3030243** (1962) & *CA* **57**, 2489 (1962) (An igniter for pyrotechnic devices and for munitions is composed of 325-mesh Zr 75, S 20, KClO₄ 5 & binder 5 parts; can function well at high altitudes and supersonic speeds) Ad 102) D.T. Zebree, *USP* **3048507** (1962) & *CA* **57**, 15405 (1962) [An electric blasting cap assembly contains a bound ignition mixt serving as a matchhead. The improved matchhead consists of a primary expl (at least one component is Diazodinitrophenol + Phenylenediamine Dipicrate) 9-70 inorg oxidizer (KClO₃ & KClO₄) 10-75 binder (NC & Nitrostarch) 1.5-15, and siliceous material (of size 0.020-4 microns) 3-55%] Ad 103) K. Okazaki, *KogyoKayakuKyokaiishi* **23**(4), 177-85 (1962) & *CA* **60**, 1528 (1964) [Reaction time and lag time determinations for ignition materials used in electric detonators gave the following results: In Tetracene & Lead Mononitroresorcinate, the reaction time is fairly long due to their comparatively slow burning time and low combstn temps. Diazodinitrophenol & 50/50 - Pb (CNS)₂/KClO₃ mixt gave a moderate reaction time; MF was also examined, but CA does not say anything about its reaction and lag time] Ad 104a) L.H. Johnston, *USP* **3040660** (1962) & *Official Gazzette*, US Pat Office, Vol **779**, No 4 (26 June 1962), p 1013; CA - not found thru 1967 (Electric initiator with

exploding wire bridge of 80% Ni & 20% Cr and expl chge of loosely packed PETN) Ad 104b) D.T. Zebree, USP **3094933**(1963) & CA **59**, 7312(1964) (Ignition compn contg Pb-Se, Pb-Te, or Pb-Se-Te is improved by addn of diatomaceous earth, such as "snow flake") Ad 105) J. Savitt et al, USP **3062143**(1962); OfficialGaz,USPatOfc, Vol **784**, No 1 (6 Nov 1962), p 113; CA - not found thru 1967 (Low energy elec detonator contg no primary but only secondary expls, which are not specified in abstract) Ad 106) T. Tosabayashi et al, JapanP **4446** (1962) & CA **60**, 5270(1964) (In manuf of slow-burning fuses, 0.05-2.0 parts of paraffin is incorporated in 100 parts of BkPdr to improve its ignitability, burning characteristics, and water proofness) Ad 107) K.K. Andreev, DoklAkadN **146**, 413-14(1962) & CA **58**, 403(1963) [Main reasons for the difference between primary and secondary expls include: 1) Primary expls are unstable in burning and convert rapidly into detonation. For example the burning of a 1-cm long cartridge of MF at 1-atm converts into deton, while similar cartridge of RDX or PETN continues to burn even at 10 and 100-atm; 2) The gaseous products of a complete chem conversion form much faster in primary than in secondary expls; 3) Having a very high temp, the gases of primary expls can easily penetrate into the depth of a cartridge, thus increasing the combustn surface, increasing the pressure and creating a deton wave. Additives, such as Al pdr, which raise the temp of gases increase the chances of the transition of a burning into expln] Ad 108) G.L. Griffith et al, USP **3082689**(1963) & CA **58**, 13704(1963) (Detonable cartridges are prepd by sheathing insensitive expl cores with sensitive expls. The method makes possible the deton of any metal-nitrate mixts and of molded, pressed, or caked AN-based expls. For example, a core of 85% NaNO₃ & 15% ground anthracite coal of density 1.38 g/cc becomes easily detonable when enclosed in a sheath of 40% Dynamite of density 1.01) Ad 109) E. Haeuseler, Explosivstoffe **11**, 226-36(1963) & CA **65**, 563(1966) [Fifteen blasting caps and fuze detonators contg MF,

MF + KClO₃, PETN & RDX and including No 8 and No 9 caps were tested for their initiating efficiency on a Pb-plate of 8-mm thick, on a Kast brisance meter and in a Trauzl lead block. Results of tests were compared with those obtd on the same apparatuses with 70/30-TNT/talc mixt, NH₄ClO₄ and PA. Description given in CA's is rather confusing and it is advisable to consult the original article in Ger. A new detonator proposed by Haeuseler consists of a Cu tube contg at its closed end 0.4 g PETN (pressed at 380 kg/cm²), with 0.2 g PETN placed on top of it (loose loaded) and 0.3 g LA (pressed at 380 kg/cm²). Oxygen balance of this mixture is - 8.6%] Ad 110) Dynamit-Nobel AG, BritP **940649** (1963) & CA **60**, 362(1964) (Priming compns for percussion and friction fuzes contg hydrated Lead Trinitrophenol instead of usual LSt and Tetracene. Some advantages are claimed) Ad 111) M.F. Murphy & B.F. Larrick, USP **3110638**(1963) & CA **60**, 3944(1964) [Friction and spark sensitivity of igniter compns contg Zr pdr and oxidizers (such as Fe oxides), is decreased in controlled manner by varying the thickness of a coating of an organopolysiloxane (such as dimethyl- or methylphenyl-polysiloxane, used in quantities 0.5 to 5.0% by wt) on the Zr particles. EtOAc or CCl₄ are used as a solvent for polysilicone] Ad 112) T.Z. Ball & W.D. Trevorow, USP **3111438**(1963) & CA **60**, 5270(1964) [Compositions for delay electric detonators consisting of a KMnO₄ oxidizer and a fuel mixt of either Zn + Si or Zn + Ti/Ni alloy. Egs: 1) KMnO₄ 100, Zn 83 & Si 9.6 parts loaded in a fuze train 0.054 inches long gave a mean delay time of 0.023 sec, while 2) KMnO₄ 100, Zn 111 & 70/30-Tl/Ni alloy 11 parts gave a mean time of 0.062 sec] Ad 112a) R.M. Hillyer & R.H.F. Stresau "EBW (Exploding Bridge Wire) Initiation of RDX with Fifty Millijoules", Paper No 5, Electric Initiator Symposium, Franklin Institute, Philadelphia, Pa, Oct 1-2(1963) Ad 113) D.T.Zebree, USP **3113519**(1963) & CA **60**, 6696(1964) (Delay fuze compns contg Ba peroxide 32-42, Te 18-48 & Se 16-50%. Such mixts

provide burning times at least 10% longer than those of BaO₂-Se or BaO₂-Te compns having the same BaO₂ content) Ad 114) T. Suzuki & K. Nakai, JapanP **942**(1963) & CA **60**, 9093(1964) [Delay electric detonators contg porous high-mol-wt compds (such as polyurethane foams, foam rubber or foamed polystyrene) as fillers between fusehead and the primary charge. It is claimed that this improved the delay time, accuracy and safety in manuf and handling] Ad 115) Sh. Kinoshita et al, JapanP **10750**(1963) & CA **60**, 6696(1964) (Delay electric detonators contg Pb oxides or chromate as an oxidizer, ferrosilicon as a reducing agent, and Al fluoride. Eg: PbO₂ 64, Fe-Si 19 & AlF₃ 17%, having a combstn rate of 40 m/sec. Such mixts do not spark on ignition, have an accurate delay time and are safe against CH₄ ignition) Ad 116) Sh. Nakahara et al, JapanP **16147**(1963) & CA **60**, 6696(1964) (A priming compn for electric detonators is made from a granular mixt of Diazodinitrophenol, fine silicic anhydride, H₂O-repellent Al silicate, a silicone oil, and a binder, such as NC dissolved in AmOAc) Ad 117) Sh. Nakahara et al, JapanP **16149**(1963) & CA **60**, 15676(1964) (Correction to previous patent) Ad 118) A.E. Lemke, Ger P **1158884**(1963) & CA **60**, 9044(1964) (Exothermic reaction mixtures for underwater propulsion and ignition devices contg alkali metal perchlorates and powdered Al, Be or Mg are improved in regard to their burning rates and pressure stability by incorporating ca. 1% of finely divided Fe) Ad 119) Dynamit-Nobel AG, BelgP **627561**(1963) & CA **60**, 1072(1964) [Dispersions of primer compns (such as mixts of LSt, Tetracene and Ba nitrate) in suspensions or solns of thermoplastic or curable synthetic material (such as a phenolic, a polyester resin, or a polystyrene) give compns which do not require high pressure for their manuf. Eg: 76 g of a primer compn is added to 24 g of an aq dispersion of polyvinylacetate and the mixt is transformed into a paste contg 16.6% solids] Ad 120) Dynamit-Nobel AG, BelgP **627564**(1963) & CA **60**, 13090(1964) (Correction of BelgP 627561) Ad 121) K. Yamamoto & T. Isotani, Kôgyo-KayakuKyôkaishi **24**(2), 79-85(1963) & CA **60**, 1527-28(1964) (Mechanism of ignition of methane-air mixtures by electric detonators I. Effects of materials and characteristics of an electric detonator on the ability to ignite methane-air mixtures) Ad 122) (?). Diehl, BelgP **630909**(1963) & CA **61**, 529-30(1964) (Electrically conductive primers are prepd by incorporating in primary mixts conductive substances such as Ag or graphite by method described in the patent) Ad 123) S. Zeman, BelgP **632157**(1963) & CA **61**, 527(1964) [Deflagrating electric initiators for rockets are prepd by coating the conductive noble metal or noble metal alloy filament of fusehead with a mixt of finely divided secondary expls (such as PETN or RDX) dispersed in a H₂O-sol silicate binder (such as Na₂O.xSiO₂ or its K analog). Insol silicates such as Na₂SiO₃ or K₂Si₂O₅ may be present also. Recommended mixts contain 40-70% of PETN or RDX] Ad 124) Imperial Chem Inds, Ltd, BelgP **634281**(1963) & CA **61**, 528-29(1964) (Initiating compns contg dextrinated LA prepd by a special method, which is described) Ad 125) L.V. Dubnov & A.I. Romanov, VzryvnDyelo, Nauchn-Tekhn-GornObshchestvo No **52/9**, pp 179-86(1963) & Ref ZhKhim **1964**, Abstr No 3N514; CA **61**, 6850(1964) (Study of conditions of ignition of HE's by an *explosive pulse*, have shown that under appropriate conditions, this process takes place quite regularly. HE's can be ignited by an impact wave at high external pressures) Ad 126) R.H. Comyn & R.E. McIntyre, NASA Doc No **63-20944**(1963) & CA **60**, 11840(1964). From SciTech Aerospace Rept **1**(21), 1743(1963) (Study of the effect of the delay-body variables on the burning characteristics of tungsten delay compns showed that increasing the mass of the delay body slows the burning of the decompn. Preliminary data indicated that the use of small diam columns may reduce dispersions) Ad 127) M.A. Hicks & Wm. Mann, Fr P **1350471**(1964) [Low-energy detonating cord free of conducting metallic sheathing and (or) reinforcement is prepd by enclosing in a fabric sheath an expl such as

PETN, followed by coating the fabric with asphalt. Such waterproof cords can be prepd with detonation velocities ranging betw 4700 & 5430 m/sec] Ad 128) K. Yamamoto, *KōgyoKayakuKyōkaishi* **25**(3), 126-34 (1964) & *CA* **61**, 11839 (1964) (Thermal decomposition and initiation of primary initiating compns based on K chlorate) Ad 129) Ibid, pp 134-44 (Initiation of lead thiocyanate-potassium chlorate mixts) Ad 130) T.Z. Ball & W.D. Trevor row, USP **3118799**(1964) & *CA* **60**, 9044 (1964) (Delay compns for electric detonators are prepd by intimately blending of finely divided Zr/Ni alloy fuel 30-85% with Si/KMnO₄ oxidizer 15-70%, followed by pelleting and granulation. Pb₃O₄ may also be used as an oxidizer) Ad 131) A.D. Coates & E.O. Baicy, USP **3120459**(1964) & *CA* **60**, 9094 (1964) [A stable powder suitable as an incendiary component, a solid rocket-fuel additive, or a metal heating pdr is obt'd by coating an oxidizer, such as K perchlorate, with 30-80% of an exothermic metal, such as Al, vapor at 5x10⁻⁴ mm Hg. Vapor is produced by heating Al ribbon or wire with Ti wire filament. The pdr can be initiated by flame or an elec impulse] Ad 132) A.M. Anzalone, USP **3121394**(1964) & *CA* **61**, 1702 (1964) (A nonmetallic detonator with casing consisting of a cellulosic material, contains as a base chge RDX, HMX, PETN, NC or Tetryl; as an intermediate chge LA, MF or DAzDNPh, added as a 2nd layer; and as a final layer, a primer prepd by blending 4 parts of 45/55-Pb(CNS)₂/KClO₃ with 1 part of polyester resin. The resin is of the unsaturated type which cures to a rigid polymer) Ad 133) R.K. Armstrong, USP **3126305**(1964) & *CA* **61**, 4142-43 (1964) (Ignition compns comprising boron-contg salts as fuels and K perchlorate, K chlorate, Na nitrate, etc as oxidizers) Ad 134) J.A.D. Eldh et al, GerP **1163211**(1964) & *CA* **60**, 15676 (1964) (In order to render harmless the hydrazoic acid which splits from LA primers, a metal powder, such as Zn or Mg, is incorporated into the casing together with LA and other ingredients) Ad 135a) J.F. Kenney, USP **3131102**(1964) & *CA* **61**, 5446 (1964) (Priming compns contg 2-10% of Tetranitrodibenzo-1,3a,4,6a-tetraazapentalene, designated TACOT. Eg: KClO₃ 53, Sb₂S₃ 25, CaSi₂ 12 & TACOT 10% mixt remained stable and sensitive when exposed to a temp of 400°F for 1300 hrs) Ad 135b) R.J. Reithel, USP **3158098**(1964) (Low-voltage detonator systems of ignition types) Ad 136) R. McGirr, USP **3135636**(1964) & *CA* **61**, 5446 (1964) [Electric detonators and squibs contg fuseheads consisting of Ni-Cr resistance wire surrounded by a bulb prepd by mixing K dinitrobenzofuroxan, and diatomaceous earth (or powdered glass) with 5% by wt of NC in soln as binder. Next to fusehead is located primary chge 10.13 g Mannitol Hexanitrate) and then as a base chge 0.65 g PETN. These detonators are sensitive to 0.36 amp] Ad 137) B.R. Adelman, USP **3140208**(1964) & *CA* **61**, 8122 (1964) [Four ignition compositions for solid rocket proplnts were prepd by tumbling the powd metallic fuel (Fe with small amts of Mg or Al) with the granular oxidizer (KClO₄) in a "sweetie barrel", in an inert atm. Ignition of these compns can be made by a squib] Ad 138) D.C. Sayles, USP **3140209**(1964) & *CA* **61**, 8124 (1964) (An explosive initiator-booster contg diethylacetylene and a perchlorate salt) Ad 139) E.E. Kilmer, USP **3150020**(1964) & *CA* **61**, 14458 (1964) (Gasless igniter compns consisting of Zr/PbO mixts) Ad 140) H. Ahrens, *Explosivstoffe* **12**(2), 35-40 & 55-60 (1964); *CA* **65**, 562-63 (1966) [Reference detonators with graduated priming effect for determining the sensitivity to initiation of explosives, are obt'd by pressing at density of 1.60 mixts PETN/KCl in ratios 100/0, 80/20, 70/30, 60/40, 50/50, ect (serving as base chges) and pressing on top of them primary expls MF or LA. These detonators are claimed to give great accuracy] Ad 141) H.S. Leopold, *NOLTR* **64-146**(1964); NASA Accession No **N65-19093**, Rept No **AD 609449**(1964) & *CA* **65**, 8656 (1966) (Investigation of initiation of PETN by exploding wires of Al, Au, Pt & W have shown that favorable wire materials are those into which energy is deposited at a rapid rate and that different wire materials have different optimum lengths for effecting detonation) Ad 142) M.G. Gilford, "The Anticipatory Effect. A Study of the Burning Mechanism of Delay-Relay Columns",

PATR 3047(1964). NASA Rept No **AD 432537**(1964); CA **66**, 8181-82(1967) [In a study of the burning mechanism of delay-relay columns, a newly recognized phenomenon termed the *anticipatory effect* is reported and its probable mechanism discussed. This effect occurs upon the burning of delay columns pressed above typical relay and flash charges and is reflected, in some systems, by >40% decrease in burning time when no thermally sensitive terminal charge is present. An important mechanism operative in propagative columnar burning of pressed delay compns, is the passage of hot gases thru pores of the column. These gases, reaction products of the burning delay compn, in the upper portions of the column, evidently precede the flame front of the column and have been shown to ignite a terminally loaded relay charge at times shorter than would have been expected were the flame front along the initiating source for the terminal charge. This effect has practical significance as it relates to end-item performance. In this investigation, the "anticipatory effect" was characterized for columns in which various delay and terminal charge compns were used
Ad 143) E.E. Kisselev et al, FizGoreniya i Vzryva **1965**(4), 83-4 & CA **65**, 6987-88 (1966). (Investigation in a shock tube of ignition of TNT and NC by shock waves, has shown that materials in powd form are much easier to ignite than those deposited as films made by drying solns on a glass)
Ad 144) M.Giltaire & J. Cocu, Explosivst **13**, 77-86(1965) (Fr) (Priming of expls in a mine by a detonating fuse in air and water
Ad 145) G.C. MacDonald, USP **3254996** (1966) & CA **65**, 5297-98(1966) [A small bomb, called "bomblet", consists of a combustible body of sintered Be or Mg, which is enclosed in a thin iron jacket. The body is partly filled with a Thermite-type expl (consisting of granular Al 16, grained Al 9, Fe₂O₃ 44, Ba(NO₃)₂ 29 & S 2%, pressed at 50 tons/sq inch), (serving as a second fire compn) and enclosing at its nose a container filled with mercury, which is connected to first-fire compn and percussion primer. Impact with a target (such as plane or

other combustible item), causes the primer to ignite thru the 1st and 2nd fire the body of the bomblet and the heat produced on burning ignites the target. At the same time Hg is evaporated with evolution of fumes, which are extremely toxic to personnel at the target] Ad 146) R.K. Armstrong, USP **3256056**(1966) & CA **65**, 8660(1966) [Electric detonators contg 2 or 3 grains of double salt of cesium dichromate and cesium decahydrodecaborate, Cs₂Cr₂O₉.(Cs₂B₁₀H₁₀)₂, as an igniter charge surrounding bridge wire, provided with 1/8 inch span. Adjacent to it are 3 grains of LA pressed at 200 psi and at the base of the cap 5 grains of PETN pressed at 200 psi. Direct current of 5 amp can be used for initiating detonators]
Ad 147) C.H. Martinez & C.R. Fingerhood, USP **3257801**(1966) & CA **65**, 10418-19 (1966) (Igniter mixts contg Al, B, KClO₄ and as binder Et cellulose can also be used as proplnts or in pyrotechnics. Eg: powd Al 22, B 38, KClO₄ 25 & Et cellulose 15% are blended in a mixer and if desired to use it as a proplnt compressed 10 to 20 thousand psi in a die heated to 95°C)
Ad 148) J.F. Kenney, USP **3262956**(1966) & CA **65**, 13450 (1966) (A series of primary expls suitable for military purposes which consist of double salts of Basic Lead Picrate with one of the following lead salts: acetate, formate, propionate, lactate, acrylate, metacrylate, and aminoacetate)
Ad 149) W.T. Bell, FrP **1426487**(1966) & CA **65**, 13450(1966) (Devices providing selective firing for several expl charges incorporated in an apparatus in oil fields' sounding perforations)
Ad 150) G.M. Pratley, USP **3264987**(1966) & CA **65**, 16785(1966) (Delayed, up to one hr, ignition in blasting can be achieved by means of a heat generating mixt of dry CaO 100, Na salicylate 2, Mg stearate 2 & sugar 2 parts, followed by addn of water. The dry mixt is placed on the bottom of a cylindrical, nonmetallic, container provided with a perforated lid. A long Al tubing closed at its bottom and contg one end of the fuse is inserted thru the perforation until the igniter mixture is reached. A calcd amt of water contained in a sealed plastic bag is released about 1 hr before

blasting. The heat generated as a result of reaction betw the above mixt and water is sufficient to ignite the fuse) Ad 150 a) Ibid & CA 65, 19923 (1966) (Correction of USP 3264987) Ad 150b) J.B. Tigrett & V.F. Wigal, USP 3272604 (1966) & CA 65, 18419-20 (1966) [A re-ignitable match capable of const ignition, burning and extinguishment over a relatively extensive life can be prepd as follows: A mixt of KClO_3 7, metaldehyde 10, MnO_2 2, Me methacrylate 4.5, NC 1.1, Bz_2O_2 0.132, PETN 2, and $\text{Fe}_2(\text{SO}_4)_3$ 1 part is extruded into rods. These are wrapped into polyethylene prior to curing by thermal or photochem means. Then the polyethylene is removed, the rods cut to desired lengths and coated with a combustible material, such as regenerated cellulose. The matches can be ignited by striking a rough surface such as sand paper] Note: Dr. Ellern (Ref 57, p 72) states that the first repeatedly ignitable match was invented in 1934 in Hungary by Z. Földi & R. Köhig and called "eternal match". Several patents (listed under Ref 221, p 434 of Ellern's book), were issued since 1934 to different inventors on the same type of match. Essentially such a match consists of a pencil-like rod, the center part of which is a safety-match composition, while the outer layer consists of a slow and cool-burning mixture whose essential, effective ingredient is metaldehyde (sometimes combined with other volatile organic substances). These devices are expensive and evaporate in storage. Repeated striking of the pre-used match fouls the striking strip so that the ignition becomes progressively more difficult Ad 151) Ministry of Aviation, London, BritP 1043534 (1966) & CA 66, 1242 (1967) [Igniter compns for use in rocket motors, fluid-ejection systems, engine-starter cartridges, etc can be prepd by mixing Al (atomized) 5, polyisobutene binder 10, Amm perchlorate 84 & surface-acting agent "S" 1%. Agent "S" consists of pentaerythritol dioleate 30, Et oleate 40 & Na di(2-ethylhexyl)-sulfosuccinate 30%. The burning rate is 0.70 in/sec and the specific impulse is 243 lb-sec/lb] Ad 152) G.T. Okhil'kov et al, RusP 184677

(1966) & CA 66, 1243 (1967) (Ignitable compn: KClO_3 49-51, Pb thiocyanate 34.7-36.7, & cryst graphite 13-15% with highly viscous collodion binder for use in bridgeless electroigniters) Ad 153) A.I. Glebovitskii & A.I. Shumskii RusP 184678 (1966) & CA 66, 1243 (1967) [Ignitable composition: K perchlorate 45-60, Pb ferrocyanide 25-45, Al powder 5-25 & collodion (or other binder) 1-2% for use in PETN detonators] Ad 154) N.J. Bowman & E.F. Knippenberg, JSpacecraftRockets 3 (10), 1542-44 (1966) & CA 66, 1995 (1967) (Pyrotechnic devices for use on sterilized spacecraft) [Biological sterilization is generally recognized as a requirement for a planetary landing vehicle. Of the possible sterilization methods, dry heat seems to be the only practical and certain method. The procedure established in 1964 by the Jet Propulsion Laboratory, Pasadena, Calif calls for three successive 36-hour heatings at 145°C . The purpose of this work is to establish which of known explosives and pyrotechnic compns can withstand sterilization without being decomposed

In the first phase of investigation, properties (such as mp, 5-sec expln temp, gas evolvn at high temps and vacuum stability) of about 150 expls were tabulated and out of this list the following were selected as more likely to withstand sterilization: Amm picrate, DATNB (or DATB) (1,3-Diamino-2,4,6-triaminobenzene); DIPAM (Dipicramid), EL-511 (Hexanitrodiphenyl Sulfone or Dipicryl Sulfone); HNDPhA (or HNDPA) (Hexanitrodiphenylamine); Cyclo-tetraethylenetetranitramine; HNO_xn (Hexanitroöxanilide); HNS (or HNS**tb**) (Hexanitrostilbene); KDNBF (Potassium Dinitrobenzofuroxan); LA (Lead Azide); NGu (Nitrogua nidine); NONA (Nona nitroterphenyl).

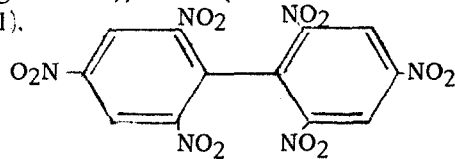

TACOT (Tetranitro-1,3a,4,6a-tetrazapentalene),

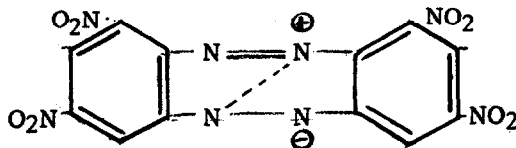

TATNB (1,3,5-Triamino-2,4,6-trinitrobenzene); TeNCbz (Tetranitrocarbazole); TeNB (1,3,5-Tetranitrobenzene); TNN (Trinitronaphthalene); Metal powder/oxidant mixture (such as B/KNO₃, Zr/KClO₄, etc); and Mg/Teflon

Three important expls: BkPdr (Black Powder); LSt (Lead Styphnate) and LMNR (Lead Mononitroresorcinate) were considered indeterminate without additional testing

The method chosen for testing BkPdr and LMNR was gas evolution at 150° in an instrument called **isoteniscope**. It consists of an Al block of sufficient mass to assure a constant test temp, heated from below by an electric heater. Holes are bored in the block to hold a test tube and thermometer. The expl sample (ca 0.5 g) is placed in a test tube, which is then filled with fine glass beads and placed in the block. The tube is closed with a perforated rubber stopper with a capillary tube for conducting gases (if any) evolved on heating to a 10-cc burette with a levelling bulb to measure the gases over mercury. The glass beads and capillary tube reduce the free volume of the system and improve the sensitivity and accuracy of measurement

No gas was evolved in testing of LMNR and BkPdr did not show any deterioration although sulfur, one of its components is volatile at 70° and melts as low as 112°. For the sake of comparison three different B/KNO₃ commercially available mixts (one being pure B/KNO₃, another a binder and the 3rd TeNCbz) and one Mg/Teflon type were tested by the same method. None of them evolved any gas. For testing LSt, it was decided that a more reliable method is to sterilize several (24) ignition elements and then see if they perform just as reliably as before sterilization. All of them passed the test

A literature survey of properties of the thousands of commercially available pyrotechnic devices showed that the majority of them would not stand sterilization. In other cases, there was insufficient information about them or their cost was unreasonably high. This eliminated all but about two dozen of commercial devices, which might prove to be suitable if the test described

below will show so. Each device was tested in a heavy-wall metal container (bomb), provided with a screw top and thermocouple. The closed bomb, containing a pyrotechnic device, was placed in an oven equipped with a temperature controller, timer and recorder. The timer was started when the temp inside the bomb reached 145°C. The criterion for acceptability was the ability to fire after being subjected to the three-cycle sterilization process

Only fourteen commercial devices were found to be sterilizable, as can be seen from Table , which is reproduced here, p D1051

As the tests proceeded, it became clear that the construction of device (besides its expl content) determines to a large extent whether it passes sterilization. This problem is discussed on p 1543 of paper

Since no sterilizable rocket igniter was available at the time of tests, the device shown on Fig 1 was designed at the General Electric Co in Philadelphia, Pa. The igniter consists of a welded, flush-mounted bridge wire with a pressed charge of basic LSt, or pure LA as the ignition element. The bridge wire ignites the styphnate, which in turn sets off the base charge (a mixt of B/KNO₃ pellets and granules) located in the same cavity. The basic elements of this system have been tested separately and proved to be satisfactory Ad 155) L.R. Rothstein et al, USP **3284255** (1966) & CA **66**, 1989(1967) (An expl initiator containing a mixt of 1 part LA with 2 parts Ba styphnate as primary expl and PETN as a secondary expl. It is claimed that LA-BaSt mixts are no more dangerous to handle than some secondary expls) Ad 156) G.W.C. Taylor & S.E. Napier, USP **3291663** (1966) & CA **66**, 5435(1967) (Pb styphnate containing Me cellulose, prep'd by special method for use in detonators & primers) Ad 157) G.W.C. Taylor & S.E. Napier, USP **3291664** (1966) & CA **66**, 5434(1967) [Primary expls, also suitable as fast-delay components, are prep'd by pptg an expl (such Ba or Pb styphnate; Pb 2,4- or 4,6-dinitroresorcinate; LA and Ba trinitrophenylglucinate) from an aq Na carboxymethylcellulose soln containing

Table 1. Pyrotechnic devices found to be sterilizable

| Designation | Type | Mfr ^a | Ignition mix | Main charge | Number tested |
|-------------|--------------------|------------------|------------------------------------|----------------------|---------------|
| ... | Ignition elements | HA | Basic lead styphnate | None | 24 |
| RXL517B | Squib | A | Lead styphnate | Lead azide | 9 |
| D45A1 | Detonator | H | Lead azide | Lead azide | 8 |
| E86 | Detonator | D | S4 | Lead azide | 18 |
| XM55 Mod 5 | Squib | MS | Zr/BaCrO ₄ | B/KNO ₃ | 6 |
| No 1554 | Initiator | MS | Zr/BaCrO ₄ | B/KNO ₃ | 6 |
| S135A0 | Squib | H | Zr/BaCrO ₄ | Pb/Se | 6 |
| S205A0 | Squib | H | Zr/KClO | Black powder | 3 |
| S11A2 | Squib | H | Lead styphnate/PbO ₂ /B | Black powder | 6 |
| PC12 | Pressure cartridge | HS | Zr/KClO ₄ /Si rubber | Zr/KClO ₄ | 12 |
| PC31 | Pressure cartridge | HS | Zr/KClO ₄ /Si rubber | Zr/KClO ₄ | 3 |
| S225D0 | Squib | H | Al/KClO ₄ | Lead azide | 6 |
| MK 5 Mod 0 | Driver | H ^b | Lead styphnate | Lead styphnate | 10 |
| S23 0 | Squib | H | Lead styphnate/PbO ₂ /B | Mg/KClO ₄ | 16 |

^a Code to manufacturers: A = Atlas Powder Company; D = DuPont Company; H = Hercules Powder Company; HA = Hanley Company; HS = HiShear Company; MS = McCormick Selph Company; and NF = Northern Flare Division, Atlantic Research Company

^b Carbon bridge

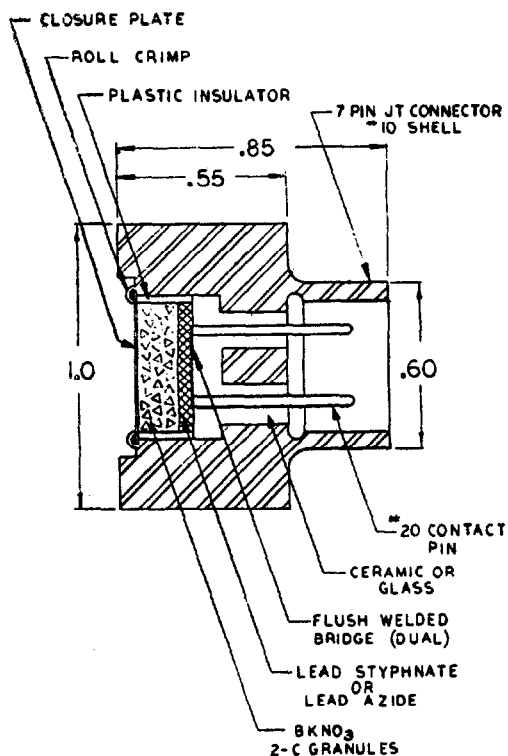

Fig. 1 Sterilizable igniter; dimensions are in inches

nonionic surface active agent (such as Empilan AQ100), followed by removing mother liquor and drying the ppt by hot air] Ad 158) Dynamit AG, FrP **1461014** (1966) & CA **66**, 10934 (1967) (A detonating fuse contg as little as 0.8 g/m of explosive is prepd by surrounding a core of DAzDNPh, Pb azide, Pb nitrophenols, Pb triethanol-ammonium perchlorate and PETN or RDX, with a sheath spun from filaments of a thermoplastic material or a ductile metal such as bronze) Ad 159) J.F. Kenney, USP **3293091** (1966) & CA **67**, 7089 (1967) [Primary expl mixts contg 46% of complex clathrate inclusion salts (as shown by X-ray diffraction data) of basic lead picrate, such as $\text{Pb}(\text{C}_6\text{H}_2\text{N}_3\text{O}_7)_2 \cdot \text{Pb}(\text{OH})_2 \cdot \text{Pb}(\text{NO}_3)_2 \cdot \text{Pb}(\text{OAc})_2$, 50% Ba nitrate & 4% Tetracene] Ad 160) H. Freiwald, "Moderne elektrische Detonatoren", Wehrtechnische Monatshefter (Defense-Technological Monthly) **1966** (11), 488-97 (20 refs) [Its subjects include: Verwendung (Uses) (p 488); Reaktionsoder, Ansprechzeit (Time of reaction) (p 489);

Energiequellen (Energy sources) (p 490); Übliche elektrische Sprengkapseln mit Glühdraht (Conventional electric blasting caps with glow wire) (p 490); Kurzzeitige Detonatoren mit Glühdraht (High-speed glow wire detonators) (pp 490-91); Detonatoren mit leitfähiger Schicht (Detonators with conductive layer) (pp 492-94); Detonatoren mit leitfähigem Initial-Sprengstoff (Detonators with conducting initiating explosive) (p 495); Elektrische Detonatoren ohne Initialsprengstoff (Electric detonators without initiating explosives) (pp 496-97) [This includes EBW (electric bridgewire) detonator called "explodierend Brückendraht." This part is abstracted in Section 3, Part E, item c of this write-up] Ad 161) A.A. Brish et al, FizGoreniya i Vzryva **1966** (3), 132-33 (1966) & CA **66**, 6373 (1967) (Initiation of detonation in condensed explosives by laser-emission) Ad 162) Imperial Chemical Industries Ltd, FrP **1462118** (1966) & CA **66**, 10934 (1967) [Manuf of detonating fuse using a specially treated PETN as a core. For this PETN grains, larger than 1.2-mm, were treated with 5% aq soln of a binder, such as poly (vinyl-acetate), excess of w removed, the moist material tumbled, then dried and loaded into sheath. The resulting fuse was crushed in order to break up the lightly bound aggregates to small grains of fairly uniform size] Ad 163) G.W.C. Taylor & J.R. White, USP **3301882** (1967) & CA **66**, 9119-20 (1967) (Delay or priming compns contg normal Lead 2,4-dinitroresorcinate prepd as described in the patent) Ad 164) G.A. Noddin, USP **3306201** (1967) & CA **66**, 10934 (1967) [An explosive waterhammer-resistant delay device for underwater work consists of a bronze cup-shaped capsule having as an igniter chge 88/10/2 mixt of Pb_3O_4 /dextrinated LA/B; as a delay a Pb tubular carrier with a mixt of B, Pb_3O_4 & dibasic Pb phosphite; and as a base chge PETN in tubular Pb carrier. Each Pb tube is pressed firmly into the capsule and the sides crimped down. The ensemble is placed into bronze tubular shell with neoprene grommets placed at each end. An expl cord threaded thru the

grommets is brought in contact with expl chge in capsule and the ensemble tested for waterproofness) Ad 165) E.A. Staba, USP **3310569**(1967) & CA **67**, 2273 (1967) (Initiating device contg double salt of Lead Styphnate and Lead Nitroaminotetrazole. A proprietary name of this salt is "Stabanate". It is described under "Double Salt, etc") (See also Refs Ad 171 and Ad 175) Ad 166) G.A. Noddin, USP **3311056**(1967) & CA **67**, 433 (1967) (A description of several nonrupturing detonating cords is given. As an example, one of them is prepd by inserting a blend of PETN 85 with equal parts mixt of butyl rubber & terpene resin 15% into an elastometric polyurethane sheath. Such sheath retains the heat, noise, and detonating products, and permits the cords to be used in critical applications, eg: the explosive sepn of missile stages of space vehicle components) Ad 167) A. Lachs, USP **3314836**(1967) & CA **66**, 10934 (1967) (Military flame-producing compns consist of colloidal yellow phosphorus dispersed in a flammable medium. A typical compn: 5 parts P (in 3:1 soln CS₂) mixed with 4 ps of rosin, 2 ps ozocerite, 5 ps paraffin (mp 48°), 3 ps kerosene or naphtha and 1.5 ps rubber cement in naphtha. The operation of mixing is protected from air by being conducted in a closed unit filled with N₂ or CO₂) Ad 168) G.B. Young & S.J. Lubinski, USP **3317360**(1967) & CA **67**, 5265 (1967) (Ignition charges for electric blasting caps, claimed to be resistant to electrostatic discharges, can be prep from amorphous B and of Pb oxides in the following mixt ranges: B 1.5-2.5 & PbO 97.5-98.5%; B 8-30 & PbO 70-92%; and B 15-30 & Pb₃O₄ 70-85%) Ad 169) T.A. Doris Jr & T.Q. Ciccone, USP **3317362**(1967) & CA **67**, 5266 (1967) (A mixt for assisting in igniting the rocket motor proplnt in an aircraft seat ejection app having catapult and rocket motors consists of: atomized Mg 14.0, BaO₂ 73.9, Zn stearate 0.9, chlorinated rubber 5.3, Toluidene Red 0.9 & Ca resinate binder 5.0%) Ad 170) W.E. Schulz, USP **3320882**(1967) & CA **67**, 6255 (1967) [High-velocity ignition-propagating cords can be prepd by loading with vibration into a lead tubing (19-inches long, 0.230-in ID & 0.500-in OD), a previously screened (to pass

28-mesh) expl mixture, prepd in the following manner. An HE (such as LA, PETN, RDX or HMX) is mixed into a paste with 5-50% of powd Al (previously blended with 1% BuOAc soln of NC), and this is followed by passing thru 42-mesh cloth screen, drying for 8 hrs at 120° F and screening to pass 28-mesh. Then the tube is drawn to a 0.055-in OD, which gives chge wt 2 g/ft. Deton vel of cord is ca 2500 in/sec] Ad 171) J.B. Tigrett & V.F. Wigal, USP **3321342**(1967) & CA **67**, 6255 (1967) [Re-ignitable match similar to the one patented by the same inventors and described here as Addnl Ref Ad 150, but of slightly different compn, namely: KClO₃ 2.3, MnO₂ 0.25, paraformaldehyde (CH₂O)_x 0.25, poly (Me methacrylate) 2.25, MeCOEt 1.0, finely divided Si 0.2, cornstarch 2.0 & Amm dichromate 0.2 part] Ad 172) E.A. Staba, USP **3321343**(1967) & CA **67**, 7089 (1967) [Percussion priming compositions contg carbon which exhibits conchoidal fracture. These compns do not have the undesirable abrasive effects of compns contg powd glass, but which have the desirable rheological and sensitivity props of the latter. The carbon materials exhibiting conchoidal fracture include ground anthracite, ground petroleum cokes, and asphalts. Following table lists rim-fire compns prepd in the lab of Olin Mathieson Chem Corp

Table 2

| Materials, % | Mix | Mix | Mix | Mix | Mix | Mix |
|------------------------|----------|----------|----------|----------|----------|----------|
| | <u>A</u> | <u>B</u> | <u>C</u> | <u>D</u> | <u>E</u> | <u>F</u> |
| Pb styphnate | 45.0 | 45.0 | - | - | - | 20.0 |
| Stabanate | - | - | 35.0 | 30.0 | 30.0 | 25.0 |
| Tetrazene | 3.0 | 3.0 | 3.0 | 3.0 | 3.0 | 3.0 |
| BaNO ₃ | 22.0 | 51.0 | 51.0 | 56.0 | 46.0 | 36.25 |
| Ground Glass | 22.0 | - | - | - | - | - |
| PbO ₂ | 7.0 | - | - | - | - | - |
| Gum Arabic | 1.0 | 1.0 | 1.0 | 1.0 | 1.0 | - |
| Karaya Gum | - | - | - | - | - | 0.75 |
| Prussian blue | 0.3 | 0.3 | - | - | - | - |
| Ground coke | - | - | 10.0 | - | - | - |
| Ground anthracite coal | - | - | - | 10.0 | 20.0 | 15.0 |

Remarks on the Table:

Stabanate is a proprietary name applied to double Pb salt of Styphnic Acid and of Nitroaminotetrazole. Its prepn is described by E.A. Staba in USP 3310569 (1967), listed here under Ad 165

Mixt A contg powd glass can be easily loaded at a water content of 13-19%

Mixts B & C can be loaded at a w content 12.5-13.5%

Mixts C, D, & E contain Stabanate instead of LSt, while Mixt F contains both

Mixt D can be easily processed with a w content 1.5-16.0%

Mixt E can be processed with a w content 12.5 to 17.0%, but some anthracite tends to separate by flotation. This effect can be prevented by reducing anthracite content and making other changes as given in Mixt F. The w content of Mixt F need not be limited during loading] Ad 173) M.T. Hedges & W.B. Freeman, IEC, ProdResDevelop 6(2), 124-26 (1967) & CA 67, 432 (1967)

[Exploding bridge wire (EBW) initiators and some detonators contain RDX processed by special recrystallization method which gave closely controlled particle size and uniform particle shape. Because of the nature of the particles, the sensitivity of the RDX chges is not affected by severe vibrations that simulate missile flight] Ad 174) G.L. Griffith et al, USP 3322066 (1967) & CA 67, 5265 (1967) (Self-destructive cartridge, used in seismic underwater explorations contains a mixt of Pentolite 89.5, Na carbonate 5.0, Na tartrate 5.0 & Na CM-cellulose 0.5%, which is enclosed in a protective water-sol film. On immersion of cartridge in water the coating dissolves and the water penetrates inside the cartridge causing interaction betw carbonate and tartrate with evolution of CO₂. The resulting pressure forces the contents of cartridge out, thus destroying it) Ad 175) H.W. Voigt, Jr, USP 3325317 (1967) & CA 67, 6254 (1967) [Lead Azide - elastometer compns in film or sheet form for use in low-impulse expls can be made by mixing, at RT, 32.8 g colloidal LA with 10-ml warm aq soln of 0.0328 g poly(vinylpyrrolidinone). A part of this product (1.25 g) was added to a

slurry of KelF-5500.422 guar gum powder (0.02 g in 0.6 g water) to form a gel paste dispersion and this was spread on a taut, leveled polyethylene sheet previously wiped with an aq butadiene - acrylonitrile dispersion] Ad 176) G.A. Noddin, USP 3326731 (1967) & CA 67, 5265-66 (1967) [Detonating expls and poly(tetrafluoroethylene) resin can be formed into sheets if processed as described in the following example. A finely divided TACOT (22 g) & the above resin (3 g) are stirred with 187 g Stoddard solvent, the suspension filtered and processed into a 0.040-in thick sheet. The sheet is dried at RT and rerolled to give a final d=1.05 g/cc. Other expls, such as HMX, RDX, PETN, LA & Dipicryl Sulfone can also be used] Ad 177) E.A. Staba, BritP 1069440 (1967) & CA 67, 5265 (1967) (Initiating expls based on Stabanate, which is a double Pb salt of Styphnic Acid and Nitroaminotetrazole. Method of prepn of Stabanate is described in this Vol under "Double Salt of Lead Styphnate and Lead Nitroaminotetrazole") (See also Refs Ad 165 & Ad 172 Ad 178) African Expls and Chem Industries, Ltd, BritP 1077649 (1967) & CA 67, 7889 (1967) (Booster compns for initiation of low sensitivity commercial expls consist of TNT 35-45, PETN 25-40 & AN 20-35%. They can be prepd by adding, with stirring, to molten TNT, the PETN slurry contg 6-10% water, allowing to stand for ca 10-min, skimming off w with impurities and adding, with stirring, to the still molten mass the calcd amt of prilled AN) Ad 179) W.E. Schulz, USP 3332311 (1967) & CA 67, 7889 (1967) [Explosive fasteners are electrically fired devices which expand on explosion fastening together various items in the same manner as do explosive rivets. They consist of metallic (such as of brass) containers filled with an expl chge which has a resistance of 10-200 ohms and which fires in 10-100 msec upon passage of an electric current of 100 to 500 thousand ergs. One of the preferred expl compns is: fine LA 70 & elec conducting powd (consisting essentially of amorphous C & graphite) 30%. For use with fasteners of low ductility ca 8% heat-sensitive expl diluent such as Tetra-

cene or the complex salt of Pb nitrate and the dibasic Pb salt of 4,6-dinitro-o-cresol is included in the chge. For use in brass fasteners with open ends, ca 30% of HNMannite & 70% conductive powd are used to avoid possible formation of unstable Cupric Azide] Ad 180) E. Matull, GerP 1249746 (1967) & CA 68, 1422(1968) [Primary expl with a definite electrical conductivity for use in elec primers. For example, an inert support in colloidal form (which is itself an elec conductor or semiconductor) is dispersed in a supersatd soln of Ag Azide in MeOH/N₃ at 50°. The solv is evaporated in vacuum and Ag Azide crystallizes out taking up the dispersed support material] Ad 181) G.W.C. Taylor et al, BritP 1086861 (1967) & CA 68, 1422 (1968) (Finely divided B is incorporated into primary expls to reduce their sensitivity to accidental ignition by electrostatic sparks. In some cases, this incorporation also increases the power & percussion sensitivity of the expls) Ad 182) D.M. Welsh, CanP 770392 (1967) & CA 68, 3093 (1968) (Describes an expl tape approx 5/8-inch wide fabricated by bonding together with a w-based latex adhesive 8 strands of textile covered detonating cord having a diam of ca 0.06-inch, the expl core of which contd 4 grains of PETN/ft and was enclosed in a textile braid. This tape has sufficient flexibility so that it can be folded back on itself or tied in knots at any point w/o cracking. It is detonated by a No 6 blasting cap applied at one end) Ad 182) Société de Prospection Electrique Schlumberger, Fr Addn 89452 (1967) to FrP 1301849 & CA 68, 5921 (1968) (Electric safety detonator compn made of a homogeneous mixt of 80/20 BaO₂/Al powd by wt) Ad 184) G.T. Okhil'kov et al, RusP 201181 (1967) & CA 68, 5921 (1968) [Igniting compn for bridgeless elec igniting devices: KClO₃ 20±1, PbCrO₄ 30±1, PbO₂ 20±1, Pb(SCN)₂ 17.15±0.85, cryst graphite 12.15±1.85, PbO 0.4±0.1, and high viscosity collodion (3% lacquer) 0.3±0.1%] Ad 185) G.W.C. Taylor, BritP 1093531 (1967) & CA 68, 6846 (1968) (Graphite-coated electrically conductive Pb

Styphnate which has reduced susceptibility to electrostatic chge accumulation Ad 186) A. Kunz et al, HungP 154401 (1968) & CA 68, 11208 (1968) (Compn for an elec igniter is made by completely surrounding a LA - dextrin mixt with either PETN or RDX. Thus, an additive for the elimination of spontaneous dropping out of the primary expl is unnecessary and also the detonating power of the igniter is increased) Ad 187) I. Lazar et al, HungP 154400 (1968) & CA 68, 11208 (1968) (The undesirable reaction between a Cu shell & LA is prevented by the presence of o- or p-aminophenols in a compn contg LA & Pb Styphnate) Ad 188) G. Cohn, Editor, "Explosives and Pyrotechnics", Newsletter issued since January 1968 by the Franklin Institute Research Laboratories, Philadelphia, Pennsylvania, Vol 2, No 1, Jan 1969, pp 2-3 [*Through Bulkhead Initiator (TBI)* was designed in 1961 for use in rocket motor and gas generator ignition systems and since that time thousands of units have been fired with no reported failures of any kind. The TBI's are available in a variety of configurations. For example, the Standard McCormick Selph Unit, P/N 805845 (manufd by the McCormick Selph, PO 6, Hollister, Calif, 95023) consists of a stainless steel, hollow, cylindrical body ca 1.67-inches long, which can be hermetically closed. It contains three charges: donor, receptor, and main chge, all of them secondary HE compns. Complete elimination of primary expl compns makes these devices safer to handle than other types of initiators. The main chge generates 3900 to 4500 psi within 0.4 millisecs in a closed volume of 10 cc. The method of initiating the TBI was not reported

More info on this subject can be obtd from five sources listed in "Explosives and Pyrotechnics"]

**List of
Picatinny Arsenal Technical Reports
on Detonators, Primers and Igniters**

PATR 1335 (1943) - See Ref 9a

- PATR 1343 (1943) - See Ref 8
- PATR 1450 (1944) - See Ref 12a
- PATR 1475 S.J. Odierno, "Effect of Variations in Shape of Firing Pin Points on Sensitivity of Detonators" (Nov 1944)
- PATR 1546 J.E. Osmun, "Surveillance Tests on M16A1 Primer Detonators Containing Type I Class B Delay Powder" (July 1945)
- PATR 1569 K.S. Warren, "Development of Priming Composition for the M41 Primer" (Oct 1945)
- PATR 1617 S. Fleischnick, "Study of Relative Initiating Efficiency of RDX in Detonators" (Aug 1946)
- PATR 1644 B.A. Lloyd, "Radiographic Study of the Fragmentation of the M-2 Electric Detonator" (March 1947)
- PATR 1657 J.P. Wardlaw, "Investigation of Two Delay Detonators (One Flame Initiated 0.10 Second, and One Stab Initiated 0.02 Second) Developed by Company A" (July 1947)
- PATR 1711 P.B. Tweed, "Black Powder for Artillery Primers" (Dec 1948)
- PATR 1751 S. Fleischnick, "Development of Improved Detonators" (Jan 1950)
- PATR 1976 T.J. Mahler & M.C. Epton, "Study of Nickel-Zirconium Type Delay Composition for Use in 11- to 14-second Primer - Detonator" (Oct 1953)
- PATR 2032 D.E. Seeger & D.H. Stone, "Development of the M36A1 Electric Detonator" (Aug 1954)
- PATR 2110 B.A. Rausch, "Application of an Improved Igniter Composition in Electric Initiating Devices" (Jan 1955)
- PATR 2145 (1955). See Ref 31
- PATR 2164 D.E. Seeger, "Investigation of the NOL No 130 Primer Mixture" (April 1955)
- PATR 2198 D.E. Seeger, "Development of the M47 (T32E1) Detonator" (July 1955)
- PATR 2203 S. Livingston, "Propellant and Explosive Ingredients of Foreign Ammunition Examined at Picatinny Arsenal in 1954" (April 1956) (Conf)
- PATR 2220 B.A. Rausch, "Evaluation of Several Styphnate-Type Primer Compositions" (Aug 1955)
- PATR 2227 A.M. Anzalone, "Non-Metallic Detonators for Non-Metallic Mine Fuzes" (Oct 1955) (Conf)
- PATR 2231 E.L. Miller, "Design and Development of Primer, Stab, T92" (Aug 1955) (Conf)
- PATR 2245 D.E. Seeger et al, "Preliminary Investigations of HMX and MEDINA for Use in Detonators" (Feb 1956) (Conf)
- PATR 2299 (1956). See Ref 32c
- PATR 2404 R.C. Ling et al, "The Effects of Momentum, Energy, and Loading Pressure on Stab Initiation" (May 1957) (Conf)
- PATR 2418 R.L. Wagner, "Evaluation of the NOL 60 Primer Mixture for Use in the M29A1 Percussion Primer" (July 1957)
- PATech Paper **DB-TP 1-57**. R. Goldstein, "Mass Production Techniques for Button-Type Electric Detonators T21E1 and T25E1 (Dec 1957)
- PATR 2482 R.L. Wagner & R.W. Snook, "Thermal Stability of Several Electric Detonators" (March 1958) (Conf)
- PATR 2510 (1958). See Ref 35
- PATR 2515 H. Hassmann, "Evaluation of EIMITE as a Substitute for Black Powder in Artillery Primers" (April 1958) (Conf)
- PATR 2519 R.L. Wagner, "Development of a Modified M47 Detonator Having Improved Cook-Off Characteristics" (June 1958) (Conf)
- PATR 2522 T. Zimmerman et al, "Combustible Primers for Use in Combustible Cartridge Cases" (Aug 1958) (Conf)
- PATR 2549 C. Ribaud & D.J. Cragle, "Polarographic Analysis of Primer Mixture for M60 Base-Detonating Fuze" (Oct 1958)
- PATR 2588 P. Murphy & A. Graff, "Development of a Primer for Use with the T1027E1 Fuze" (Jan 1959) (Conf)
- PATR 2594 D.E. Seeger & R.E. Trezona, "Development of the 50-Millisecond-Delay T65 Electric Detonator" (April 1959) (Conf)
- PATR 2599 R.E. Trezona & D.E. Seeger,

- "Development of Electric Detonators T60 and T61" (March 1959) (Conf)
- PATR 2606 F.K. VanArsdel, "Development of T6 Electric and T7 Nonelectric Blasting Caps" (April 1959) (Conf)
- PATR 2610 D.E. Seeger et al, "Development of a Detonator for Use in the T358 Shell System" (July 1959) (Secret)
- PATR 2645 E. Bertrand, "Development of a Pyrotechnic Photo Relay for Use with a Photocell Contact Fuzing System" (March 1960)
- PATR 2654 F.K. VanArsdel, "Development of the T29 and T48 Stab/Electric Detonators" (Dec 1959) (Conf)
- PATR 2655 R.E. Trezona, "Development of the T62 Electric Detonator" (Dec 1959) (Conf)
- PATR 2662 R.L. Wagner, "Lead Azide for Use in Detonators" (Jan 1960)
- PATR 2667 R.C. Ling et al, "Temperature Coefficient of Mechanical Sensitivity of Primary Explosives" (Feb 1960) (Conf)
- PATR 2672 B. Werbel & W.M. Stirrat, "Development of a Pyrotechnic Delay for the Vigilante 37-mm T324 HE Cartridge" (April 1960) (Conf)
- PATR 2680 A.C. Forsyth et al, "A Study of Stab Initiation Mechanisms" (April 1960) (Conf)
- PATR 2700 Vol 1 (1960). See Ref 43
- PATR 2700 Vol 2 (1962). See Ref 44
- PATR 3050 R.E. Trezona, "Development of Detonator, Electric: XM64" (March 1963)
- PATR 3064 E.L. Miller, "Development of XM66E2 Electric Detonator for Use in Type 19 Spotting Device" (March 1963)
- PATR 3110 L. Shainheit & R.L. Wagner, "Determination of the Feasibility of Initiating PB-RDX Pellets Using the M46 Stab Detonator" (Sept 1963)
- PATR 2700 Vol 3 (1966). See Ref 48
- PATR 3352 R.W. Snook, "Development of XM83 Percussion Detonator" (April 1966)
- PATR 3366 J.G. Pelphey, "Evaluation of RDX for Exploding Bridgewire Detonators" (May 1966)

- PATR 3402 J. Velasquez, "Air Gap Tests for XM813 Fuze for Shillelagh II" (July 1966)
- PATR 3449 S. Vishnefsky, "Feasibility Study of Side Thruster for MAW System" (Aug 1966)

**List of
Picatinny Arsenal Technical Reports
on Fuzes**

- W.F. Shirk, "Tests of Fuze, Mine, Anti-Tank, M1 to Determine the Safe Insulation between Fuzes Against Progressive Detonation", PATR 1176 (Aug 1942)
- D. Hart, "Gasless Powders for Delay Elements of Fuzes". PATR 1239 (Feb 1943) & PATR 1281 (April 1943)
- D.E. Sanford, "Development of the Loading Technique of the 20-mm Fuze, Percussion, DA No 253", PATR 1295 (June 1943)
- D. Hart, "Gasless Powders for Delay Elements of Fuzes", PATR 1406 (March 1944)
- K.S. Warren, "Investigation of Primer Mixture for Fuze, Chemical, Mine, A-T, N-M, M5", PATR 1411 (April 1944)
- D. Hart, "Gasless Powders for Delay Elements of Fuzes", PATR 1513 (March 1945)
- D. Hart, "Investigation of the Use of Nitroindene Polymer in Powder for M54 Time Fuze", PATR 1525 (May 1945)
- A.F. Schilling, "Examination of German, Chemical, Long Delay, Bomb Fuze, E1AZ (57)", PATR 1572 (Oct 1945)
- A.B. Schilling, "Examination of German, Mechanical, Time Long Delay, Bomb Fuze, L ZTZ (17) B*", PATR 1574 (Nov 1945)
- A.B. Schilling, "Examination of German, Instantaneous and Long Delay Fuze, ELE AZ 55A", PATR 1581 (Nov 1945)
- D. Hart, "Development of Smoke Composi-

tion for the Fuze, Chemical, Mine, AT, Practice, T20", PATR **1596** (April 1946)

M.C. Epton, "Long Range Development of Delay Powders for Ammunition Fuze Application Bomb Fuzes", PATR **1686** (April 1948)

D. Hart, "Long Range Development of Delay Powders for Ammunition Fuze Application", PATR **1733** (June 1949)

J.R. Caporaso, "Effect of 240°F Temperature on Explosives in T729E3 Nose Bomb Fuze", PATR **1788** (Oct 1950)

S.H. Liff, "Fuze Sealants", PATR **1899** (Oct 1952)

M. Klein & J. Bolognese, "Investigation of the Feasibility of an Electromagnetic Induction Fuze for Photoflash Cartridges", PATR **1917** (Jan 1953)

M.T. Hedges & T.J. Mahler, "Surveillance Study of Nickel-Zirconium Type Delay Powder for M205 Hand Grenade Fuze", PATR **1952** (Aug 1953)

T. Fruchtman, "Analysis of Warhead and Fuze Used in the Anti-Tank Guided Missile SS-10", PATR **1982** (Dec 1953)

S. Helf et al, "Development of an Inspection Method Using a Radioactive Tracer for Detecting the Firing Pin Support in PD Fuze M48A3", PATR **2030** (June 1954)

S.H. Liff, "Examination and Evaluation of Fuze; Bomb, Nose Model AM-A Soviet, FMAM 2232", PATR **2066** (Oct 1954)

B.V. Frank & J. Fruchtman, "A Study of Hydraulic and Pneumatic Arming Delay Mechanisms for Fuze, Rocket PD, T2019", PATR **2073** (Oct 1954)

S.H. Liff, "Examination and Evaluation of Fuze; Bomb, Tail, Model AD-A Soviet, FMAM 2254", PATR **2084** (Dec 1954)

S.H. Liff, "Examination and Evaluation of Fuze, PD, Type 137, Communist Chinese for

Shell, 60-mm, Mortar, HE, Long (High Capacity), FMAM-2336 (MCN-5654)", PATR **2085** (Jan 1955)

Cpl M. Kanner, "Feasibility Study of an Electronic Grenade Fuze", PATR **2134** (Feb 1955)

D.J. Zauder & M.C. Epton, "Characteristics of M204 Hand Grenade Fuzes Loaded with Nickel-Zirconium Type Delay Powder", PATR **2178** (May 1955)

A.M. Anzalone, "Non-Metallic Detonators for Non-Metallic Mine Fuzes", PATR **2227** (Oct 1955)

D.J. Zouder et al, "Development of Zirconium-Nickel Alloy Delay Powder for M204A1 Hand Grenade Fuzes", PATR **2228** (Jan 1956)

C.A. Knapp & G. Weingarten, "White Smoke Composition for Fuze, Mine, AT, Practice, M604", PATR **2285** (July 1956)

R.A. Greenberg, "Development of Pyrotechnic Delay Trains for the T2049 and T2066 Rocket Fuzes", PATR **2365** (Oct 1956) (Conf)

C.P. Iosso, "Evaluation of Explosive Train of DOFL Development Model T905 Electric Bomb Fuze", PATR **2394** (Feb 1957) (Conf)

C. Ribaud & R.J. Cragle, "Polarographic Analysis of Primer Mixture for M60 Base-Detonating Fuze", PATR **2549** (Oct 1958)

E. Bertrand, "Development of a Pyrotechnic Photo Relay for Use with a Photocell Contact Fuzing System", PATR **2645** (March 1960)

List of Picatinny Arsenal Memorandum Reports on Fuzes

A.B. Schilling, "Soviet and Satellite Fuzing Mechanisms", PAMR **23** (Oct 1952); Addenda Nos 1, 2, 3, 4 & 5 (March 1953); Addendum **6** (Aug 1953); Addendum **7** (Dec 1953)

S.H. Liff, "Soviet and Satellite Fuzing Mechanisms. Fuze, PD, SD, A-37U (Soviet) for 37-mm Cartridge, HE1-T, Type OZT, for N-37 Aircraft Gun", FMAM-2362, PAMR 54 (May 1954)

G. Wright, "Group I Test on Safety and Arming Mechanisms for T3000 and T3001 VT Fuzes", PAMR 57 (May 1954)

S.H. Liff, "Examination and Evaluation of Shell, 60-mm Mortar, HE, Long, High Capacity, W/LG Warhead (Comm Chinese) FMAM-1883 and Fuze, PD Impact, Type (?) for 60-mm Mortar Shell, HE, Type (?) Long, High Capacity, W/LG Warhead, (Comm Chinese) FMAM-1883A" PAMR 78 (July 1955)

V.T. Riedinger, "Examination of Rocket, 83-mm, HEAT, Mod (?), Energa Blindicide, Later Model with Fuze, PI, BD, Belgian", PAMR 80 (July 1955)

S.H. Liff, "Examination and Evaluation of Fuze, Rocket, PD, Model K VD, Oerlikon Swiss", PAMR 81 & 82 (Feb 1956)

S.H. Liff, "Fuze, PI, BD, for Rocket, 83-mm, HEAT, Model (?), Energa Blindicide, Belgian, FMAM-none", PAMR 83 (May 1955)

S.H. Liff, "Examination and Evaluation of Fuze, Bomb, Nose/Tail, Model APUV (Soviet) and Fuze, Bomb, Nose/Tail, Mod APUV-1 (Soviet)", PAMR 84 (Nov 1955)

A.J. Marhefka, "Examination and Evaluation of Fuze, Bomb, Nose/Tail, Model AV-1 (Soviet)", PAMR 87 (Sept 1955)

A.B. Schilling, "Examination and Evaluation of Fuze, Grenade, Model (?) for Mod RG-42 Grenade (Soviet)", PAMR 94 (Aug 1955)

A.J. Marhefka, "Examination and Evaluation of Fuze, PD, Impact, Model MKE 101 for Mortar Shell (Copy of French Brandt Type), with Adapter and Booster (Turkish)", PAMR 102 (March 1956) (Conf)

A.J. Marhefka, "Examination and Evaluation of Fuze, Bomb, Nose Model AVSH-2, Soviet", PAMR 104 (April 1956) (Conf)

R. C. Schofield, "Examination and Evaluation of Fuze, PD, Impact, Model MP-82, Soviet", PAMR 133 (Jan 1957) (Conf)

R.C. Schofield, "Examination and Evaluation of Fuze, Bomb, Tail, Model ADP, Soviet", PAMR 135 (March 1957) (Conf)

A.B. Schilling, "Examination and Evaluation of Fuze, Bomb, Model ADOZ - Soviet", PAMR 136 (March 1957) (Conf)

R.C. Schofield, "Examination and Evaluation of Fuze, Bomb, Nose, Model AGDT-B, Soviet", PAMR 137 (Feb 1957) (Conf)

A.B. Schilling, "Examination and Evaluation of Fuze, Bomb, Nose, Model AM-B, Soviet", PAMR 138 (Feb 1957) (Conf)

A.B. Schilling, "Examination and Evaluation of Fuze, Bomb, Nose, Model AGM-3, Soviet", PAMR 139 (March 1957) (Conf)

V.T. Riedinger, "Examination and Evaluation of Fuze, PD, Model Z-21, for 82-mm Recoilless, HEAT, Cartridge, Model T-21, 'Tarasnice', Czech", PAMR 141 (April 1957) (Conf)

R.C. Schofield, "Examination and Evaluation of Fuze, Bomb, Nose, Model AGP, Soviet", PAMR 143 (April 1957) (Conf)

V.T. Riedinger, "Examination and Evaluation of Fuze, Electric, BD, Model (?), Swiss", PAMR 144 (May 1957) (Conf)

J.H. Korte, "Examination and Evaluation of Fuze, Pull Type, Model RO-1 for Land Mines, Czech", PAMR 146 (June 1957) (Conf)

V.T. Riedinger, "Examination and Evaluation of Fuze, Pressure Type, Model RO-8 for Land Mines, Czech", PAMR 147 (March 1957) (Conf)

V.T. Riedinger, "Examination and Evaluation of Fuze, PD, Model (?), W/Detonator, Experimental, Swiss", PAMR 152 (Nov 1957) (Conf)

V.T. Riedinger, "Examination and Evaluation of Fuze, PD, Model GK-1, Soviet", PAMR 160 (Nov 1958) (Conf)

A.B. Schilling, "Examination and Evaluation of Fuze, BD, Model MR-Z, Soviet", PAMR 168 (Jan 1960) (Conf)

A.B. Schilling, "Examination and Evaluation of Fuze, PD, Model AZ DM 111 for 81-mm Mortar, West German", PAMR 169 (April 1960) (Conf)

V.T. Riedinger, "Examination and Evaluation of Fuze, Tilt Rod, Czech", PAMR 176 (March 1961) (Conf)

Section 8 ANALYTICAL PROCEDURES FOR EXPLOSIVE COMPOSITIONS USED IN DETONATORS, PRIMERS, IGNITERS AND FUZES

Analyses of unknown samples of explosives used in primers and detonators before WWII in the Laboratoire Centrale de Poudres, Paris, are described in Vol 1 of Encycl, p A580-R (Ref 18)

Analytical procedures for initiating expls described in Vols 1, 2 & 3 (Refs 18, 20 & 34) are not repeated here and only typical procedures which are listed in other refs are described

In StdMethodsChemAnalysis 2B (1963) (Ref 30, pp 1369-70) are given brief descriptions of analytical procedures for the following primer mixtures: a) LA, K chlorate, Sb sulfide & carborundum and b) LA, Ba nitrate, LSt, Sb sulfide & Tetracene. Mixture a) is described in Ref 18, p A584 and Mixture b) on p A586

Lusardi (Ref 24) describes in Section 200 the following analytical procedures used for artillery detonator, primer and igniter compositions:

Method No 202. *Primer Mix US Army Standard.* US Military Specification MIL-D-2493 (1950) and PA-PD-124 (1953) requirements: Moisture, max 0.30% and Composition: K chlorate 33.4±2.0, LA 28.3±2.0, Sb sulfide 33.3±2.0 & carborundum 5.0±0.5%. In more recent Specs MIL-D-002493, Interim Amendment 1 (MU) (1964) and in Spec MIL-D-46256A (MU) (1965), analytical procedures are the same as in older Specs. These procs are described in Vol 1 of Encycl (Ref 18, p A581-L). Determination of K chlorate by the method developed at PicArns is also described in Vol 2 of Encycl (Ref 20, p C196)

Method No 203. *Primer Mix, New No 4* has been used principally in rifle grenade fuzes and bomb primer detonators. US Military Spec MIL-P-2499 (1950) requirements: Moisture, max 0.30%; and Composition: MF 35, Sb sulfide 30 and K chlorate 35%

Procedures:

a) *Moisture.* Dry in a desiccator over Ca chloride to constant wt an accurately weighed 0.8 g sample in a tared glass weighing dish ca 55-mm diam & 30-mm high, and calc from the loss in wt the percentage of moisture. A similar method used in pyrotechnics is described as Method 101.1.1 in MIL-STD-1234 (1965). Vacuum desiccator may be used to shorten the period of drying

b) *Mercuric Fulminate.* Transfer the accurately weighed sample of opn a) to a 250-ml beaker. Add quickly at RT 30-ml of freshly prep'd 20% Na thiosulfate soln, stir the mixture for exactly 1 min and titrate immediately with N/10 HCl soln, using 3 drops of methyl red as the indicator. Add most of the pre-calculated amt of HCl at once and complete the titration in not more than 1 min. Use this liquid immediately for the next procedure. Make later a blank detn with the same quantity of Na thiosulfate soln but without the sample

$$\text{Percent of MF (based on purity of 99\%)} = \frac{7.188(A-B)N}{W}$$

where: A = ml of N/10 HCl soln used;
B = ml of N/10 HCl soln used in the blank detn;
N = normality of HCl soln; and
W = wt of dry sample in grams

c) *Antimony Sulfide*. Filter immediately thru a tared filtering crucible, the contents of the beaker remaining at the end of MF titration. Wash the insol material with distd w at RT, and discard the filtrate and washings. Rinse the residue, with small amts of alc & ether, and dry at 100°. Cool, weigh and calc as percent of Sb_2S_3 . Identification of ppt can be made by microscopic or chem examination

d) *Potassium Chlorate*. Calc its percentage by subtracting from 100 the sum of the percentages of MF & Sb sulfide

Method No 204. *Primer Mix V*. US Military Spec MIL-P-2523 (1950) requirements: Moisture, max 0.30%, and Composition - TNT, ground glass, Pb thiocyanate, Ba nitrate & K chlorate (percentages are not given). A slightly different composition and procedures than given below are described in more recent Spec entitled "Primer, Percussion, M39A1" (See Method No 204a, described below)

Procedures:

a) *Moisture*. Use 0.6 g sample and the same procedure as described under Method No 203

b) *TNT*. Dissolve with stirring, an accurately weighed dry sample from opn a) in a 150-ml beaker, using 25-ml of ether, and filter thru a tared sintered glass crucible into vacuum flask. Rinse the residue in a crucible with several portions of ether, dry the ensemble at 100°, cool, and weigh. Calculate the loss in wt as the percentage of TNT

c) *Ground Glass*. Wash the insol material in crucible with five 5-ml portions of 5% K nitrate soln, allowing each portion to remain in contact with the residue for 2-3 mins before applying vacuum. Wash with w at RT, saving the washings together with the filtrate for the next operation. Dry the crucible with residue at 100°, cool and weigh. Calc the wt of insol material as the percentage of glass

d) *Lead Thiocyanate*. Transfer the combined filtrate and washings from previous operation into a beaker, add an excess of N/10 Ag nitrate soln, boil, and allow ppt to settle. Filter thru a tared sintered glass crucible, wash with w and save the filtrate and washings for the next opn. Dry the crucible at 135°, cool and weigh. The wt

of ppt, which is AgCNS, is multiplied by factor 0.9742 to obtn the wt of $Pb(CNS)_2$

e) *Barium Nitrate*. Transfer into a low beaker the filtrate and washings from previous opn, and evaporate to ca 100-ml. Add to the boiling soln 10-ml of 10% sulfuric acid, allow the ppt to settle, and filter thru a sintered glass crucible, previously ignited, cooled and tared. Wash with four 10-ml portions of acid ammonium acetate, (which is prepd by mixing 120-ml of glac AcOH, 100-ml of distd w & 93-ml of concd Amm hydroxide), followed by rinsings with distd w. Ignite the ppt of Ba sulfate at a dull red heat, cool and weigh. Multiply the wt of ppt by 1.1197 to obtn the wt of $Ba(NO_3)_2$

f) *Potassium Chlorate*. Calc its percentage by subtracting from 100% the sum of the percentages of TNT, glass, Pb sulfocyanate and Ba nitrate

Method No 204a. *Primer, Percussion, M39A1*. Its compn is TNT 5.7, Pb thiocyanate 38.1, K chlorate 37.1, Ba nitrate 8.7 & ground glass 10.4%. Tests described in US Military Specification, MIL-P.12951D (MU) (1965) are given below:

Procedures:

a) *Moisture*. Use a 0.6 sample and procedure a) of Method No 203

b) *TNT*. Same as proc b) of Method No 204

c) *Ground Glass*. Same as proc c) of Method No 204

d) *Lead Thiocyanate*. Same as proc d) of Method No 204

e) *Potassium Chlorate*. Add to the beaker contg the combined filtrate and washings from the detn of Pb sulfocyanate, 5-ml of 40% formaldehyde in order to reduce the chlorate to chloride so that it can be pptd by Ag nitrate used in opn d) and still present in the filtrate. Allow the ppt of AgCl to settle, and filter thru a tared sintered glass crucible. Wash the beaker and crucible with w adding the washings to the filtrate. Save the liquid for proc f. Dry the crucible at ca 135°, cool and weigh. Subtract the wt of empty crucible to obtain the wt of AgCl

$$\text{Percent of } KClO_3 = \frac{85.5A}{W}$$

where: A = wt of ppt and
W = wt of dry sample

f) *Barium Nitrate*. Evaporate the combined filtrate and washings of opn e) to ca. 100-ml and add to the boiling soln 10-ml of 10% sulfuric acid. After allowing the ppt of Ba sulfate to settle, filter the liquid thru a tared, previously ignited and cooled, sintered glass crucible. Wash the ppt with four 10-ml portions of acid ammonium acetate (prepd by mixing 120 -ml of glac AcOH, 100-ml distd w, & 96-ml of concd ammonium hydroxide), followed by distd w. Dry the crucible with ppt and ignite to a dull red heat. Cool in a desiccator, weigh and subtract the wt of empty crucible

$$\text{Percent of Ba(NO}_3)_2 = \frac{111.97A}{W}$$

where: A = wt of Ba sulfate and
W = wt of dry sample

g) *Water-Soluble Binder*. Subtract from 100 the sum of percentages of TNT, ground glass, Pb sulfocyanate, K chlorate & Ba nitrate

Method No 205. *Primer Mix No 70*, has been used in fuzes of armor-piercing projectiles. US Military Spec MIL-P-20414 (1951), requirements are: Moisture, min 0.30% and Composition - TNT (Grade I) 5.0±0.5, Sb sulfide 17.0±2.0, Pb thiocyanate 25.0±3.0 & K chlorate (plus gum) 53.0±5.0%

More recent Spec, MIL-P-13392A (MU) (1964) entitled "Primer, Percussion, M54", with Amendment 1 (1965), and Engineering Order EO-PA-49681-2 (1967) do not give the percentages of ingredients, but describe the same procedures as in the Method No 205 of Lusardi's Manual

Procedures:

a) *Moisture*. Transfer 1 g of the sample to an accurately tared sintered glass crucible and, using a wooden spatula, quickly spread the sample in a thin layer over the bottom of the crucible. Weigh rapidly (but accurately) and allow the crucible to remain at least 16 hrs (such as overnight) in a desiccator contg Ca chloride. Reweigh accurately and calc the loss in wt to percentage of moisture in the sample

b) *Trinitrotoluene*. Add to the dried sample in the crucible 15-ml of anhydrous chloroform and, after allowing the solvent to stand in contact with the sample for 5 mins, gently and carefully crush the lumps, using the flat end of a wooden rod. Allow the sample to drain thru the filter without suction and repeat the extraction with 2 more 15-ml portions of chlf. Ascertain the completeness of extraction by adding the last 1 or 2 drops of filtrate dripping from the crucible at the end of the 3rd extraction to 2 drops of N/1 alcoholic soln of NaOH placed on a white spot plate. If a red coloration appears, continue extraction using another 15-ml portion of chlf and repeat the test for coloration. If no red color appears, draw air thru the crucible until no odor of chlf remains and then dry the crucible at 100° for 15 mins, cool and weigh. Calc the loss in wt to the percentage of TNT in the sample. Discard the filtrate and wash the suction flask

c) *Antimony Sulfide*. Connect the crucible with residue to the suction flask and add 20-ml of approx 25% warm Amm acetate soln. Allow to stand for 10 mins while breaking up any lumps with the flattened end of a glass rod. Suck the soln into the clean flask and repeat the treatment with 2 more 20-ml portions of warm Amm acetate soln. At the end of the 3rd treatment, ascertain the completeness of extraction by collecting 2 drops of the filtrate on a white spot plate and treating them with 2 drops of dilute nitric acid and 2 drops of slightly acidified ferric alum soln. If extraction is not complete, as shown by the red coloration, continue treatment of the residue with warm 10-ml portions of Amm acetate until completion of extraction, which will be shown by absence of red coloration after performing the above test. Wash the residue and crucible with w, collecting the washings together with Amm acetate filtrate. Total vol should be 150 to 200-ml. Then rinse with alc & ether, aspirate until the odor of ether is no longer detectable, dry in an oven at 100° for 15 mins, cool in a desiccator and weigh. Subtract from this wt the wt of an empty crucible and calc the difference to

percentage of Sb_2S_3 in the sample on a moisture-free basis

d) *Lead Thiocyanate*. Transfer the filtrate and washings from the previous opn to a 400-ml beaker, add 2 ml of glac AcOH and heat to boiling. While stirring vigorously, add slowly 8 ml of 5% K dichromate soln, stir for 1-2 mins longer and digest on a steam bath for 1 hr with frequent stirring. Collect the reddish-orn ppt of Pb chromate on a tared sintered glass crucible, and wash it eith hot w. Dry the crucible with ppt for 2 hrs at 100° , cool in a desiccator, and weigh. Calc the increase in wt to percentage of $Pb(CNS)_2$ in the sample on a moisture-free basis by multiplying the wt of ppt by 100.05

e) *Potassium Chlorate Plus Gum*. Subtract from 100 the sum of the percentages of TNT, Sb sulfide, and Pb sulfocyanate and report the remainder as percentage of K chlorate plus gum. Correct the percentage of K chlorate by subtracting 0.70% for gum content

Method No 206. *Primer Mix PA-100*, applicable to M15A2 and other detonator assemblies, has been used in fuzes for 20-mm ammunition. US Military Specification MIL-P-14100 (Ord) (1955), requirements are: Moisture, max 0.30% and composition - K chlorate 53.0 ± 2.0 , Sb sulfide 17.0 ± 1.0 , LA 5.0 ± 1.0 & Pb thiocyanate $25.0 \pm 1\%$. More recent Spec is MIL-D-002493, Interim Amendment 1 (MU) (1964). The procedures were developed at PicArns and are described in Vol 1 of Encycl (Ref 18, p A583-L) as Method 2

Method No 207. *Primer Mix NOL No 130*, applicable to M46 and other detonators; has been used in fuzes for 20-mm ammunition. US Military Specifications PA-PD-202 (1952) and PA-PD-124 (1953) requirements are: Moisture, max 0.30% and composition - Ba nitrate 20.0 ± 2.0 , Basic LSt 40.0 ± 2.0 , Tetracene 5.0 ± 0.5 , Sb sulfide 15.0 ± 1.5 & Dextrinated LA $20.0 \pm 2.0\%$. More recent Spec MIL-P-14137A (MU) (1963) entitled "Primer, Stab M106", with Amendment 1 (1965) describes the same procedure as given in earlier Specs and as in the Method V of Vol 1 of Encycl (Ref 18, p A586-L), entitled:

"Analysis of Mixtures Containing Lead Azide, Barium Nitrate, Basic Lead Styphnate and Antimony Sulfide". In this title the word "Tetracene" was erroneously omitted (See also Method No 207a)

Method No 207a. US Military Spec MIL-D-45441C (MU) (1966) covers the requirements of *Stab Detonator M61*, while MIL-D-462098B (MU) (1968) covers the requirements of *Detonator M44E1*. Composition of primer mixture for each of these detonators is the same as listed in Method No 207, except that Basic LSt can be replaced by Normal LSt. Following are the procedures:

a) *Moisture*. Use 1 g of accurately weighed sample and procedure a) of Method No. 203

b) *Barium Nitrate*. Use the procedure b), described in Vol 1 of Encycl (Ref 18, p A586-L), except that the sample should be the dried sample of opn a)

c₁) *Basic Lead Styphnate* (when applicable). Use procedure c), described in Vol 1 of Encycl (Ref 18, p A586-R). The value 28 in the equation is a factor (F), which is different for each instrument. This factor must be detd for each instrument on the basis of the sample of LSt that is suitable for use as a standard

c₂) *Normal Lead Styphnate*. Use the same procedure as for Basic LSt, but in calcn use factor (F) of 29.41 instead of 28 used for Basic LSt. Factor 29.41 is given in MIL-STD-650 (1962), where under Method 408.1 is described the procedure for detn of Normal LSt

d) *Tetracene*. Use the procedure d) described in Vol 1 of Encycl (Ref 18, p A587-L). It is the same proc as described in Specs MIL-D-45441C (MU) (1966) and MIL-D-46209B (MU) (1968)

e) *Antimony Sulfide*. Use the calcn described in Vol 1 of Encycl (Ref 18, p A587-L)

f) *Lead Azide*. Determine its percentage by subtracting from 100% the sum of percentages of Ba nitrate, LSt, Tetracene and Sb sulfide

Method No 208. *Primer Mix for M3 Ignition Cartridge*. US Military Specification MIL-C-20480A (1954) requirements are: Moisture, max - percentage not given, and its compo-

sition is: MF, Sb sulfide, ground glass, K chlorate and water soluble binder (percentages are not given)

Procedures:

a) *Moisture.* Use the procedure described under Method No 2. The wt of sample should be such that it contains ca 0.3 g MF

b) *Mercuric Fulminate.* Transfer the dried sample of previous opn into a dry 250-ml beaker, moisten it with 1-2 drops of alc at RT and add 30 ml of 20% Na thiosulfate soln. After stirring thoroughly for ca 55 secs, add 70 ml of distd w and immediately titrate with N/10 sulfuric acid, using methyl red as indicator until the color changes from red to yel. It is important to begin the titration exactly 1 min after the addn of the thiosulfate soln and to run the acid from the burette at such a rate that the time of titration does not exceed 1 min. Make a blank detn using the same amt of thiosulfate soln, alc & w, but no sample. Make calcn after running the test for Sb sulfide

$$\text{Percent of MF} = \frac{(A-B) \times N \times (0.0711565) \times 100}{W}$$

where: A = ml of acid used in titration;
B = ml of acid required for blank detn;
N = normality of acid; and
W = wt of dry sample in grams

c) *Antimony Sulfide.* Filter immediately thru a tared ignited Selas crucible, the contents of beaker remaining from previous opn, into another 250-ml beaker. Wash the residue with w (at RT collecting the washings together with the filtrate), followed by rinsing with alc & ether. Save the liquid for the next opn. Dry the crucible by aspiration and then by heating in an oven at 100° to constant wt. Cool in a desiccator and weigh, thus obtg the wt of Sb sulfide, plus glass (if any). In order to separate glass, transfer with a glass spatula the bulk of residue in the crucible to a small beaker, add a mixture of 40 ml concd HCl with 10 ml of concd nitric acid and boil long enough to completely dissolve Sb sulfide. Transfer the mixture into the same crucible as above, stir with the flattened end of a glass rod in order to dissolve any Sb sulfide adhering to the walls and bottom of crucible. Aspirate, wash the

small beaker with 10 ml of HCl-HNO₃ mixt, transfer the acid to the crucible in order to dissolve remaining traces of Sb sulfide and aspirate again. Ignite the crucible with contents, cool and weigh. Subtracting this wt from the wt of crucible contg both Sb sulfide and glass, gives the wt of Sb₂S₃ alone

d) *Ground Glass.* Subtraction of the wt of empty crucible from the wt of crucible contg glass, gives the wt of glass

e) *Potassium Chlorate.* Add to the combined filtrate and washings of opn c), located in the 250-ml beaker, one ml of concd sulfuric acid and 20 ml of 10% ferrous ammonium sulfate soln. Boil for 5 mins, cool, and add 5 ml of 10% Ag nitrate soln. After allowing the ppt to settle overnight in a dark place, filter by aspiration the supernatant liquid thru sintered glass crucible, transfer the ppt to the crucible by means of a thin stream of w from a wash bottle, wash it with w and then with two washes of alc. Remove the adhering sulfur by rinsing the ppt (under the hood) with 2-3 small portions of carbon disulfide, aspirate to remove the odor of disulfide, and dry at 130°. Cool, weigh and calc K chlorate content from the equation:

$$\text{Percent of KClO}_3 = \frac{S \times 0.8550 \times 100}{W}$$

where: S = wt of AgCl in the crucible in grams,
W = wt of dry sample

f) *Water Soluble Binder* is detd by subtracting from 100% the sum of all the percentages previously detd

Method No 209. *Primer Mix in the M29A1 Percussion Primer*, used in artillery fuzes. US Military Specification MIL-P-2496D (1967) requirements: Moisture, max 0.30% and Composition: TNT, Sb sulfide, Pb thiocyanate & K chlorate. Percentages of ingredients are not given

Procedures:

a) *Moisture.* Use 1 g accurately weighed sample and the same procedure as described under Method No 203

b) *Trinitrotoluene.* Transfer the dried sample of opn a) to a 150-ml beaker, add 25 ml of ether and stir to dissolve TNT. Filter thru a tared sintered glass crucible, transferring the insol residue with small portions of

ether from a wash bottle. Dry the crucible and residue by aspiration and at 100° in an oven. Cool in a desiccator, weigh and calculate the loss in wt to percentage of TNT in dry sample

c) *Antimony Sulfide*. Add to the residue in the crucible 75 ml of 5% K nitrate soln in 5 ml portions, allowing each portion to remain ca 3 mins before applying suction. Wash the contents of the crucible with distd w, combining the washings with the filtrate. Dry the crucible with contents at 100°, cool in a desiccator and weigh. Calc the wt of the insol residue to the percentage of Sb₂S₃ in the sample

d) *Lead Thiocyanate*. Transfer the filtrate with washings into a beaker, add an excess of 0.1N Ag nitrate soln, boil and allow the ppt of AgCNS to settle. Filter thru a tared sintered glass crucible, wash the ppt with w and save the filtrate with washings. Dry the crucible with contents at 135° to constant wt, cool in a desiccator and weigh. Subtracting from this the wt of empty crucible, the wt of AgCNS is obt'd and calculate

$$\text{Percent of Pb(CNS)}_2 = \frac{97.43A}{W}$$

where: A = g of AgCNS and
W = g of sample

e) *Potassium Chlorate*. Transfer the filtrate and washings of previous opn into a beaker, add 5 ml of 40% formaldehyde soln and 3 ml of nitric acid. Boil to reduce the chlorate to chloride and add an excess of Ag nitrate. Allow the resulting ppt of AgCl to settle, filter thru a tared sintered glass crucible, and wash with distd w. Then dry at 135° to constant wt, cool in a desiccator, and weigh. Subtract the wt of empty crucible to obtain the wt of AgCl and calculate

$$\text{Percent of KClO}_3 = \frac{85.50A}{W}$$

where: A = wt of AgCl and
W = wt of dry sample in grams

Method No 210. *Priming Composition (Lead Starter Type)*, used as a priming compn for the M127 (T73) Parachute White Star Ground Signal. US Military Specification MIL-S-13257F (1967) requirements: Moisture, max 0.10%, and Composition: Pb peroxide (of

95% PbO₂ min) 33.33:2, Silicon (powdered) 33.33:2 & Cu oxide (of 95% CuO min) 33.33:2.

Procedures:

a) *Moisture*. Transfer 10 g of an accurately weighed sample to a tared moisture dish 2 inches in diam and reweigh the ensemble and place it in an oven at 100-105° for 1 hr. Cool in a desiccator and reweigh. The loss in wt, multiplied by 100 and divided by wt of sample is percent of moisture content

b) *Silicon*. Transfer an accurately weighed 1 g sample to a 100-ml beaker, and add 20 ml of 3N nitric acid & 0.5 ml of 30% hydrogen peroxide. Heat on a steam bath for 1 hr, add 20 ml of distd w and filter thru a sintered glass crucible. Wash the beaker with a small amt of hot w from a wash bottle and add the washings to the crucible. Aspirate and wash the ppt in the crucible with a small amt of hot w. Save the liquid for the next opn and dry the crucible with ppt at 100-105° for 1 hr. Weigh after cooling in a desiccator and calc the gain in wt of the crucible to percent of Si in the dry sample

c) *Lead Peroxide*. Transfer the filtrate with washings of the previous opn into a beaker and add, with stirring, 8 ml of 35N sulfuric acid. Heat, under a hood, on hot plate until sulfur trioxide fumes are produced. Cool the beaker for 2 mins and add slowly 5 ml of w. Reheat the beaker until sulfur trioxide fumes are produced, cool and add 100 ml of w. Allow to stand for at least 1 hr and filter thru a tared Selas crucible. Wash the beaker with ca 25 ml of 1N sulfuric acid, and transfer washings to the crucible. Aspirate and wash the ppt of Pb sulfate in the crucible with 1N sulfuric acid. Disconnect the suction flask and transfer its contents to a beaker for use in the detn of CuO. Connect the crucible to an empty suction flask and wash the ppt with 50% ethanol soln to remove the sulfuric acid. Reject the alcohol washings. Dry the crucible at 100° for 15 mins and then place it in a furnace at 500° for 15 mins. Cool in a desiccator, weigh and calc the gain in wt of the crucible (due to ppt of Pb sulfate) to percent of Pb peroxide in the dry sample

$$\text{Percent of PbO}_2 = \frac{78.88A}{WP}$$

where: A = wt of ppt in the crucible;
 W = wt of dry sample; and
 P = purity of Pb peroxide expressed
 as a decimal fraction

d) *Copper Oxide*. Add to the filtrate and washings saved from previous opn, 10 ml of 15N Amm hydroxide to neutralize most of the sulfuric acid. Heat the soln to ca 80° and plate the copper out using revolving electrodes, with tared cathode, using a current of 1 to 1.4 amperes per sq cm and about 5 volts. After 2 hrs of plating, test for the completeness of opn by adding ca 10 ml of w to the plating soln and observing if after 10 mins of plating any more Cu is deposited on the freshly exposed cathode surface. Consider the plating completed if no fresh deposit is observed. Wash the cathode with w from a wash bottle, without breaking the circuit, and then with alcohol, after disconnecting the circuit. Dry the cathode in an oven at 100-105° for 15 mins, cool it and weigh. Calc the gain in wt of the cathode to percent CuO in the dry sample

$$\text{Percent of CuO} = \frac{125.17A}{WP}$$

where: A = gain in wt of cathode;
 W = wt of dry sample; and
 P = purity of CuO expressed as
 a decimal fraction

Method No 211. *Primer Mix*, which contains K chlorate 14.0, LA 33.0, Sb sulfide 21.0, powdered glass 30.0 & shellac 2.0%. Its method of analysis was described by the late T.D. Dudderar in PicArsnChemLabRept 49344 (1937) and in Vol 1 of Encycl (Ref 18, p A585-R). It is not found in Lusardi's "Laboratory Manuals"

Method No 212. *Igniter, Primer, Electric*, M74. US Military Spec MIL-I-46521B (MU) (1966) requirements are: Moisture, max 0.10%; Composition - K chlorate 44.5, Pb thiocyanate 35.5, charcoal 20.0, lacquer solids added 1.6, 0.2%

Procedures:

a) *Moisture*. Transfer a 1.6 g sample to a tared, high form, medium porosity, sintered glass, filtering crucible, weigh accurately

the ensemble and allow to air dry for ca 1 hr. Place in a vacuum oven at 55±2° for 2 hrs, cool in a desiccator and weigh. Repeat drying opn until the change in wt does not exceed 0.5 mg. Calc the loss in wt as moisture content

A more tedious procedure for this compn, using acetyl chloride & pyridine and involving titration is described in PA-PD-2005 (1960) and in MIL-P-46279 (Ord) (1960) [See also Method 101.1.1 in MIL-STD-1274 (1965)]

b) *Lacquer Solids*. Extract the crucible contents with ten 25-ml portions of acetone (previously satd with K chlorate & Pb thiocyanate), aspirate until the disappearance of acetone odor and dry in a vacuum oven at 55±2° for 2 hrs. Cool in a desiccator, weigh and calculate:

$$\text{Percent Lacquer Solids} = \frac{100(A-B)}{B}$$

where: A = wt of sample dried in the oven;
 B = wt of sample after acetone
 extraction of lacquer solids

c) *Charcoal*. Extract the residue of previous opn with ten 25-ml portions of a 5% K nitrate soln (using the flattened end of glass rod to break any lumps), followed with two 25-ml washes with distd w. Save the filtrate with washings for opn d) and dry the residue in the crucible, first by aspiration and then by heating for 2 hrs in an oven at ca 100°. Cool in a desiccator, weigh and calc:

$$\text{Percent of Charcoal} = 100C/B$$

where: C = wt of residue after acetone and
 K chlorate soln extraction;
 B = wt of sample after acetone
 extraction

d) *Lead Thiocyanate*. Add to the vacuum flask contg the filtrate and washings of opn c), exactly 35 ml of standardized 0.1N Ag nitrate, swirl and add 100 ml of 3N white nitric acid (free of nitrogen oxides). After continuing to swirl for an addnl 5 min add 5 ml of a satd ferric ammonium sulfate soln. Titrate with standardized 0.1N K thiocyanate soln to the first pale rose coloration

$$\text{Percent of Pb(CNS)}_2 = \frac{16.17(AE-CD)}{B}$$

where: A = ml of Ag nitrate soln used;
 B = wt of sample after acetone extraction;
 C = ml of K thiocyanate used in titration;
 D = normality of K thiocyanate soln;
 E = normality of Ag nitrate soln

e) *Potassium Chlorate*. Subtract from 100% the sum of charcoal and thiocyanate percentages

Note: A similar procedure is described in PA-PD-2005 (1960) and in MIL-P-46279 (Ord) (1960) for igniter compn used in Electric Primer M75. The components of mixture are the same as described in Method No 212 **Method No 213. Igniter Composition Type 1 of Delay Charge Composition F33B.** Its composition: Diatomaceous Earth (Silicon Oxide), Ferric Oxide, Zirconium & Acetate Resin and procedures are given in Specification MIL-D-46206D (MU) (1966). Same compn (but without acetate resin) and the same procedures are given in MIL-D-46483B (MU) (1964) for "Igniter Composition in Delay Elements T6E4 and T5E3". Percentages of ingredients are not given in the above Specs. Slightly modified procedures are described in Engineering Order EO-PA-52713-2 (1968)

Procedures:

a) *Moisture.* (max 0.04%). Heat a 10 g sample in a vacuum oven at 100° to constant weight as described in MIL-STD-1234 (1965), Method 102.1.1

b) *Silicon Oxide (Diatomaceous Earth).* Transfer an accurately weighed 1 g dried sample to a 250-ml Erlenmeyer flask and add 20 ml of 85% sulfuric acid (sp gr 1.77). Heat gently at first to dissolve ferric oxide and then more vigorously to dissolve zirconium. Continue the heating until white fumes of sulfur trioxide are evolved. The presence of iron oxide is indicated by the formation of ppt which redissolves when the soln is cooled and cautiously diluted with 50 ml of w. If any red or gray particles remain undissolved, reheat the mixt until the appearance of white fumes, etc. Finally, dilute to 150 ml with distd w and filter thru

a No 42 Whatman paper (or its equivalent), and wash with ca 40 ml of warm dilute (1:100) sulfuric acid. Collect the filtrate and washings in a 250-ml volumetric flask and save without filling to the mark for opn c) Place the filter paper with ppt in a tared Pt crucible, and dry in an oven at 100-110° for 2 hrs. Then place the crucible with filter in a cold muffle furnace, raise the temp to 300-400° in order to char the paper, and finally to ca 1000°, maintaining the temp until complete incineration (ca 30 mins). Cool the crucible in a desiccator and weigh. Add to the ignited residue 5 ml concd hydrofluoric acid & one drop concd sulfuric acid. Evaporate the acid, ignite the residue, cool in a desiccator and weigh. The difference in wt before and after adding HF is due to the loss of silica

$$\text{Percent of SiO}_2 = 100A/W$$

where: A = loss of wt on treating with HF;
 W = wt of dry sample

c) *Ferric Oxide.* Fuze the nonvolatile residue in Pt crucible with 1 g of K bisulfate, cool and dissolve the melt in hot w. Transfer the soln to the 250-ml volumetric flask that contains the filtrate of opn b) and fill it to the mark with distd w. Transfer a 50-ml aliquot from the flask to a beaker, add 50 ml of concd HCl, and heat the soln to near boiling point. Add dropwise, with stirring, stannous chloride soln (3 g SnCl₂ dissolved in 10 ml HCl diluted to 20 ml with w), until the color of the liquid changes from yel to lt grn. If this color change is not sharp, discard the soln, take a new 50-ml aliquot, evaporate to 10-15 ml, add an equal vol of concd HCl and proceed with SnCl₂ reduction as described above. Add 1 or 2 drops of SnCl₂ soln in excess, cool to RT and rapidly add 10 ml of satd aqueous mercuric chloride soln. If the ppt formed is very heavy or is other than white, it means that too much SnCl₂ has been used and that the reduction process must be repeated with another aliquot and a smaller amt of SnCl₂. If ppt is white and not heavy, allow the mixture to stand for ca 5 mins, and transfer it to a 600-ml beaker with the aid of ca 250 ml of w from a wash bottle.

Cautiously add, with stirring, 15 ml of sulfuric acid, 5 ml of phosphoric acid, and 6 to 8 drops of Na diphenylamine sulfonate indicator soln (0.2 g/100 ml of w). Titrate slowly with 0.05N std K dichromate soln until the pure grn color changes to a gray-green. Then add the dichromate one drop at a time until the first tinge of purple or violet-blue appears

$$\text{Percentage of Fe}_2\text{O}_3 = \frac{(39.92)VN}{W}$$

where: V = ml of std K dichromate soln used;
N = normality of std dichromate soln;
W = wt of dry sample

d) *Zirconium*. Transfer a 50-ml aliquot from 250-ml volumetric flask of opn b) to a 250-ml beaker, add 50 ml of 6% aqueous mandelic acid soln, and place on a steam bath for 1 hr. The formation of white ppt indicates zirconium. Remove from the bath, let stand for at least 3 hrs and filter the soln thru an 11-cm No 40 Whatman paper (or its equivalent). Transfer the ppt from the beaker using a policeman and a stream of soln contg 5 g of mandelic acid and 2 ml of HCl per 100 ml of w. Place the filter paper in a tared Pt crucible, and dry the ensemble in an oven at 100 to 110° for 2 hrs. Then transfer it to a cold furnace, heat at 300-400° until the paper has been completely charred and finally ignited at ca 1000° in 30 mins. Cool in a desiccator and weigh as Zr dioxide. If the ppt is not white but brn, add 1 g of powdered K sulfate, mix well and fuze. Cool, transfer to a beaker, dissolve in hot w, add 5 ml of concd HCl, dilute to 50 ml, and proceed as before by pptg with mandelic acid

$$\text{Percent of Zirconium} = \frac{74.03A}{W}$$

where: A = wt of ZrO₂; and
W = wt of dry sample

Note: Both above specifications give 370.2 as the factor, which seems to be an error
e) *Acetate Resin*. Subtract from 100% the sum of percentages of diatomaceous earth, ferric oxide and zirconium

Method No 214. *Igniter Composition Type II of Delay Charge Compositions Z-2A or Z-2B.* Its composition: Barium Chromate, Zirconium & Acetate Resin and procedures

are given in Specification MIL-D-46206 (MU)(1966). Percentages of ingredients are not listed

Procedures:

a) *Moisture* (max 0.04%). Heat a 10 g sample in a vacuum oven at 100° to constant wt. This method is described in MIL-STD-1234 (1965), Method 102.1.1

b) *Barium Chromate*. Transfer the accurately weighed dry sample used in proc a) to a 250-ml beaker, add 50 ml of dilute perchloric acid (1:20) and heat on the steam bath until the dissoln of Ba chromate. Dilute to ca 100 ml with w and filter thru a No 42 Whatman paper (or its equivalent) into a 250-ml volumetric flask. Wash the residue with 25 ml of dil perchloric acid (1:100), followed by 50 ml of w, collecting the washings together with the filtrate. Save the filter paper with residue for Zr detn. Fill the volumetric flask to the mark and pipet a 50-ml aliquot into a 400-ml beaker for the chromate detn. Dilute to 250 ml, and add 10 ml of dilute sulfuric acid (1:4) and 10 ml of phosphoric acid (1:1). Add a measured excess consisting of ca 30 ml of standardized 0.05N ferrous ammonium sulfate soln and 6 to 8 drops of Na diphenylamine sulfonate indicator soln (0.2 g in 100 ml of w). Titrate the excess ferrous iron with 0.05N std K dichromate soln, adding the dichromate slowly with stirring, until the pure grn color changes to gray-grn. Then add the dichromate one drop at a time until the first tinge of purple or violet-blue appears

$$\text{Percent of BaCrO}_4 = \frac{42.23(VN-CM)}{W}$$

where: V = ml of standardized ferrous ammonium sulfate soln used in titration;

C = ml of std K dichromate soln;

N = normality of std ferrous ammonium sulfate soln;

M = normality of std K dichromate soln; and

W = wt of dry sample

c) *Zirconium*. Transfer the filter paper with the Zr ppt from the Ba chromate detn to a 250-ml Erlenmeyer flask, add 10 ml of concd sulfuric acid and concd nitric acid

to dissolve the Zr and destroy the filter paper. Heat, directly over burner with constant swirling, to white fumes of sulfur trioxide, adding more nitric acid dropwise if the soln darkens. Cool and cautiously wash down the sides of the flask with ca 25 ml of w from a wash bottle. If any insol material remains in the flask, repeat the heating to white fumes, while adding some nitric acid dropwise. Transfer the clear soln to a 200-ml volumetric flask and fill to the mark. Transfer a 50-ml aliquot to a 250-ml beaker, add 50 ml of 16% mandelic acid and continue as described in opn d) under Method No 213

$$\text{Percent of Zirconium} = \frac{74.03A}{W}$$

where: A = wt of ZrO_2 ; and
W = wt of dry sample

Note: MIL-D-46206D (p 17) gives 296.1 as the factor, which seems to be an error
d) *Acetate Resin*. Subtract from 100%, the sum of percentages for Barium Chromate and Zirconium

Method No 215. *Delay Composition for Delay Elements T6E4 and T5E3*. Specification MIL-D-46483B (MU) (1964) states that it consists of Lead Chromate (and/or Barium Chromate) and powdered Manganese, but does not list the percentage of components. Procedures were changed by Engineering Order EO-PA-52713-2 (1968)

Procedures:

a) *Moisture* (max 0.04%). Heat a 10 g sample in a vacuum oven at 100° to constant wt. This method is described in MIL-STD-1234 (1965), as Method 102.1.1

b) *Lead Chromate and/or Barium Chromate*. Transfer a 0.5 g accurately weighed dry sample to a 400-ml beaker, add 25 ml of 20% Amm acetate soln, heat to boiling, allow to settle and decant the supernatant liquor into another beaker. Repeat the extraction twice more, combine the extracts and cool to RT. Place a narrow piece of blue litmus paper against the inside of the beaker contg extract with ca 0.5 inch dipping into the soln. Add 0.2N HCl soln dropwise with constant stirring, until the lower part of litmus paper just turns pink. The forma-

tion of a white ppt indicates the presence of lead. Add to the undissolved portion remaining in the 1st beaker 200 ml of 10% HCl and heat to boiling. If the soln is not clear, filter a portion thru a coarse filter paper, heat ca 100 ml of the clear soln to boiling, and add slowly 10 ml of 50% sulfuric acid. A white ppt indicates barium, which can be confirmed by the grn color obtd in a flame test. Filter and add to the cool filtrate 1 ml of concd HCl. A white ppt indicates the presence of lead

If both Ba and Pb chromates are present, the following quantitative method can be used:

Transfer ca 0.5 g of accurately weighed dry sample to a 500-ml Erlenmeyer flask, add 200 ml of 10% HCl, cover and heat to boiling. Filter thru an 11-cm Whatman No 40 paper (or its equivalent) into a 400-ml beaker, wash the residue on filter with four 10-15-ml portions of 1% HCl soln and combine washings with the filtrate. Heat this liquid to boiling, add slowly 20 ml of 50% sulfuric acid and continue boiling for 5 mins. After allowing the liquid to stand at 60° or higher until the ppt settles, decant the liquid thru a tared, fine porosity Sela crucible and transfer the ppt by means of a stream of w and policeman. Wash the ppt with three 25-ml portions of 0.5% sulfuric acid and then with dilute alc (1:1) until free of acid. Dry the ppt in crucible for 30 mins at ca 110° and then ignite for 60 mins at 750° . Cool in a desiccator and weigh, recording the wt as Ba sulfate and Pb sulfate

Extract the Pb sulfate from the crucible by treating with hot liquid, contg 20 g ammonium acetate and 3 ml of glac AcOH per 100 ml of w. Wash thoroughly with hot w, followed by hot 10% sulfuric acid (to remove the acetate) and finally with dil alc (1:1) until free of acid. Dry the ppt at 110° and 750° as before, cool, weigh and record as Ba sulfate. The loss of wt is equal to the wt of Pb sulfate

$$\text{Percent of } BaCrO_4 = \frac{108.6A}{W}$$

where: A = wt of $BaSO_4$ and
W = wt of dry sample

$$\text{Percent of PbCrO}_4 = \frac{106.6B}{W}$$

where: B = wt of PbSO₄ and
W = wt of dry sample

c) *Manganese*. Transfer a sample of 0.1 g of dry material to a 250-ml Erlenmeyer flask, add 10 ml of w, 30 ml of 50% nitric acid and 2 ml of 60% perchloric acid. Evaporate the soln until almost dry and then cool. Add 50 ml of w, 1 ml of 10% ferric nitrate and 2% of K chromate. Cover the flask with a watch glass, boil the soln for 15 mins, cool, and adjust the vol to 50 ml. The formation of a purple permanganate color indicates the presence of manganese. This method is described in EO-PA-52713-2 (1968). The following method is described in MIL-D-46483B (MU) (1964):

Transfer a 0.5 g accurately weighed dry sample to a 500-ml Erlenmeyer flask, add 25 ml of w, 30 ml of 50% nitric acid and 2 ml of 60% perchloric acid. Stir to dissolve the sample and heat to evaporate the soln until almost dry. Cool and add 50 ml of w, 1 ml of 10% ferric nitrate and 2% of K chromate. Cover the flask with a watch glass, boil the soln for 15 mins, cool, adjust the vol to 50 ml and filter thru an 11-cm Whatman No 42 paper (or its equivalent), wash the ppt with w and transfer it together with the filter to a tared Pt crucible. Dry and ignite to MnO₂, cool and dissolve in sulfuric acid. Expel the excess of acid by heating, filter the residue off, wash with w, dry and weigh Mn sulfate

$$\text{Percent of Manganese} = \frac{36.38A}{W}$$

where: A = wt of Mn sulfate and
W = wt of dry sample

Method No 216. *Igniter Composition for Blasting Fuse, Friction Type, M3A1.* PicArns Purchasing Description PA-PD-2111D issued in 1966 for use pending revision of Spec MIL-I-12597A lists the following ingredients of this igniter compn: Charcoal, Potassium Chlorate & Dextrin, without giving their percentages

Procedures:

a) *Moisture*. Place three loaded igniter cups

in a tared, previously dried for 1 hr at 100° and cooled, 30-ml beaker, weigh, heat again for 1 hr at 100°, cool in a desiccator and reweigh

$$\text{Percent of Moisture} = \frac{100B}{W}$$

where: B = loss of wt on drying and
W = wt of 3 loaded igniter cups minus the wt of 3 empty cups as determined in opn c)

b) *Charcoal*. Add to the beaker of previous opn, 20 ml of w, heat to boiling and continue to heat until the material is completely leached from the igniter cups. Filter thru a tared Selas filtering crucible No 3010 (or equivalent), while transferring the residue quantitatively, without cleaned empty cups. Dry them and weigh. Subtract their wt from wt of sample. Wash the residue in the crucible four times with hot water, combining the washings with the filtrate. Save this liquor for opn c). Dry the crucible for 1 hr at 100° to 105°, cool in a desiccator and weigh

$$\text{Percent of Charcoal} = \frac{100(C-A)}{W}$$

where: A = wt of empty crucible;
C = wt of crucible with ppt of charcoal; and
W = wt of 3 loaded igniter cups, minus wt of 3 empty ones

c) *Potassium Chlorate*. Transfer the filtrate saved from opn b) to a calibrated 250-ml volumetric flask and pipet out a 25-ml aliquot to a 500-ml Erlenmeyer flask. Add ca 125 ml of w and 50 ml of 18N sulfuric acid. Stopper the flask with a rubber stopper equipped with a Bunsen valve and heat to almost boiling. Add, by means of a calibrated pipet, 50 ml of ca 4%, previously standardized, ferrous ammonium sulfate (Mohr's salt) soln and boil for 2 mins. Cool, loosen the Bunsen valve and titrate the excess of ferrous ion with a std 0.1N soln of K permanganate. Concurrently, conduct a blank detn using the same reagents, but without the sample

$$\text{Percent of KClO}_3 = \frac{20.43(V_1 - V_2)}{W}$$

where: V_1 = ml of K permanganate soln required for blank;

V_2 = ml of K permanganate soln required for sample; and

W = wt of sample without cups

d) *Dextrin*. Subtract from 100% the sum of charcoal and potassium permanganate percentages

Method No 217. *Friction Composition for Blasting Fuse, Friction Type, M3A1.* Acddg to PA-PD-2111D(1966), the mixture consists of Red Phosphorus and Orange Shellac (no percentages given)

Procedures:

a) *Moisture*. Place the completely coated section of four friction wires in a tared, previously dried for 1 hr at 50°, and cooled 30-ml beaker, heat the beaker again for 1 hr at 50°, cool and reweigh

$$\text{Percent of Moisture} = \frac{100A}{W}$$

where: A = loss of wt on heating; and
 W = wt of dried friction compn, determined as described under opn b)

b) *Red Phosphorus*. Add to the dried friction wires of previous opn, 20 ml of 95% ethyl alc and boil the contents on a steam bath until the friction compn is completely removed from the wires. Filter the liquid thru a sintered glass filtering crucible, taking care to transfer the compn quantitatively, while leaving the cleaned wires in the 30-ml beaker. Wash the residue in the crucible with five portions of hot 95% ethyl alc, dry for 1 hr at 50°, cool and weigh. Consider the gain in wt of the crucible as the wt of red P in the sample. Dry the beaker with four cleaned friction wires for 1 hr at 50°, cool and weigh. Consider the loss in wt as the wt of dried friction compn and calculate as follows:

$$\text{Percent of Red Phosphorus} = \frac{100B}{W}$$

where: B = wt of red P; and
 W = wt of dried friction compn (obtd by subtracting from the wt of four coated friction wires, the wt of four cleaned friction wires)

c) *Orange Shellac*. Subtract from 100%, the percentage of red phosphorus

Method No 218. *Igniter Composition for M31 Series Detonators* (and some other detonators). Specifications PA-PD-124(1953) and MIL-D-002493, Interim Amendment 1 (MU)(1964) give its compn as: Lead Thiocyanate & Potassium Chlorate, without listing the percentages of ingredients

Procedures:

a) *Moisture*. Use a 1 g accurately weighed sample and the procedure described under Method No 203

b) *Lead Thiocyanate*. Transfer a 1 g accurately weighed dry sample to a 250-ml beaker, add ca 20 ml of distd w and stir with a rubber policeman until the sample is thoroughly wetted. Add, with stirring, a known volume (ca 35 ml) of standardized N/10 silver nitrate soln, followed by 100 ml of 10% nitric acid, which is free of nitrogen oxides. Continue to stir for addnl 5 mins and add 5 ml of satd ferric ammonium sulfate soln. Titrate with standardized N/10 K thiocyanate to the first permanent pale rose coloration and calc as follows:

$$\text{Percent of Pb(CNS)}_2 = \frac{16.25AN}{W}$$

where: A = difference between the total mls of Ag nitrate soln added and its equivalent to the K thiocyanate used;

N = normality of Ag nitrate soln; and

W = wt of dry sample

Note: This calcn is based on Pb thiocyanate purity of 99.5%

c) *Potassium Chlorate*. Subtract from 100% the percentage of Pb thiocyanate
Method No 219. *Igniter K29* (for use in Tracer R-45, described under Method No 220). Its compn: Barium Peroxide (min purity 88%; See Note) 80.5±2.0, Magnesium Powder 16.5±2.0, Calcium Resinate 2.0±0.5 and Graphite 1.0±0.5% is given in MIL-C-14334 (Ord)(1956) and in MIL-T-46245C(MU), Amendment 1 (1964), but procedures are only in MIL-C-14334

Note: This purity is sufficient to give a minimum of 6.5% available oxygen (See

Vol 1 of Encycl, p A515-L). In Engineering Change Order No 130225 (1957), the requirement for BaO₂ changed from "88% Purity" to "Available Oxygen from Barium Peroxide 6.5% min"

Procedures:

a) *Moisture* (max 0.14%). Place an accurately weighed 5 g sample in a tared dish 2 inches in diameter, heat for 2 hrs in an oven at 135°, cool and weigh. Calc the loss in wt to percent of moisture

b) *Barium Peroxide (Available Oxygen)*. Transfer an accurately weighed 0.5 g of dry sample (passing thru ca 100-mesh US Std Sieve), to a 300-ml tall form beaker. Cool the beaker to ca 10° and add 50 ml of distd w (cooled to 10°±2°), contg 2 drops of 1% Mn phosphate soln (prepd by dissolving 0.1 g of Mn in 10% phosphoric acid). Titrate immediately with standardized 0.1N K permanganate soln, contg 10% by volume of 85% phosphoric acid. The titration shall be conducted rapidly by adding most of the precalculated permanganate soln as fast as the burette allows and with a minimum of stirring. Several mls before the end of titration, stir the liquid sufficiently to dissolve the undissolved BaO₂. Continue the titration drop by drop until 1 drop of permanganate soln produces a pink coloration which remains permanent for 1 min

$$\text{Percent Available Oxygen} = \frac{0.800VN}{W}$$

where: V = ml of permanganate soln used;
N = its normality; and
W = wt of dry sample

c) *Magnesium (Eudiometer Method)*. Assemble the gas evolution apparatus as shown in Fig, reproduced from MIL-STD-1234 (1961), Method 412.1. It consists of a 600-ml, wide mouth, Erlenmeyer flask fitted with a 2-hole rubber stopper and a 25-ml buret for 10% sulfuric acid with its tip inserted thru one of the holes. Thru other hole is inserted a tube leading to a "U" shaped tube contg "Ascarite" for absorbing any evolved carbon dioxide. A 3-way "T" type stopcock is inserted between the drying tube and the gas buret so that the Erlenmeyer flask can be exposed to atm pressure. The gas buret,

calibrated from 450 ml to 500 ml is connected to a water-leveling bulb filled with dist w saturated with hydrogen. This buret is water-jacketed to achieve accurate and rapid temperature control. A circulating pump is used to circulate the tap water, (maintained at temp of 25°) thru the jacket and the water reservoir in which the Erlenmeyer flask is immersed in order to maintain it at the same temp as the gas buret

For detn of Mg, transfer ca 2.4 g of accurately weighed, previously dried sample to a medium porosity sintered glass filtering crucible and extract with six 5-ml portions of chloroform, allowing each time the chlf to drain thru the residue before applying suction. After addn of the last portion, air dry the residue by suction until the disappearance of odor of chlf, and transfer the crucible with residue (without reweighing) to the 600-ml Erlenmeyer flask shown in Fig. Connect the flask to the apparatus, leaving the 3-way "T" stopcock open so that the flask and the gas burette are exposed to atm pressure. Adjust by means of a leveling bulb the liquid in gas buret to zero and turn the "T" stopcock so that it will only allow gas to flow from the flask to the gas buret. Lower the leveling bulb, and add 25 ml of 10% sulfuric acid from the 25-ml buret. Close the stopcock of the buret and allow the reaction to proceed, while occasionally shaking the flask until the evolution of gas ceases. Consider the reaction as complete if the volume of the generated gas in the buret remains within 1 ml for a period of 20 mins. When the reaction is complete, adjust the level on the gas buret to that of the water in leveling bulb. If the volume of gas is not sufficient to fill the 450-ml bulb of the gas buret, add to the 600-ml flask a known amt of w from 25-ml buret until a readable volume is reached on the gas buret

$$\text{Percent of Magnesium} = \frac{(A-B)(C-D)0.03901}{W(273+t)}$$

where: A = ml of gas read on gas buret;
B = ml of acid added from buret (25 ml) or this vol plus w added to adjust the vol in gas buret to readable

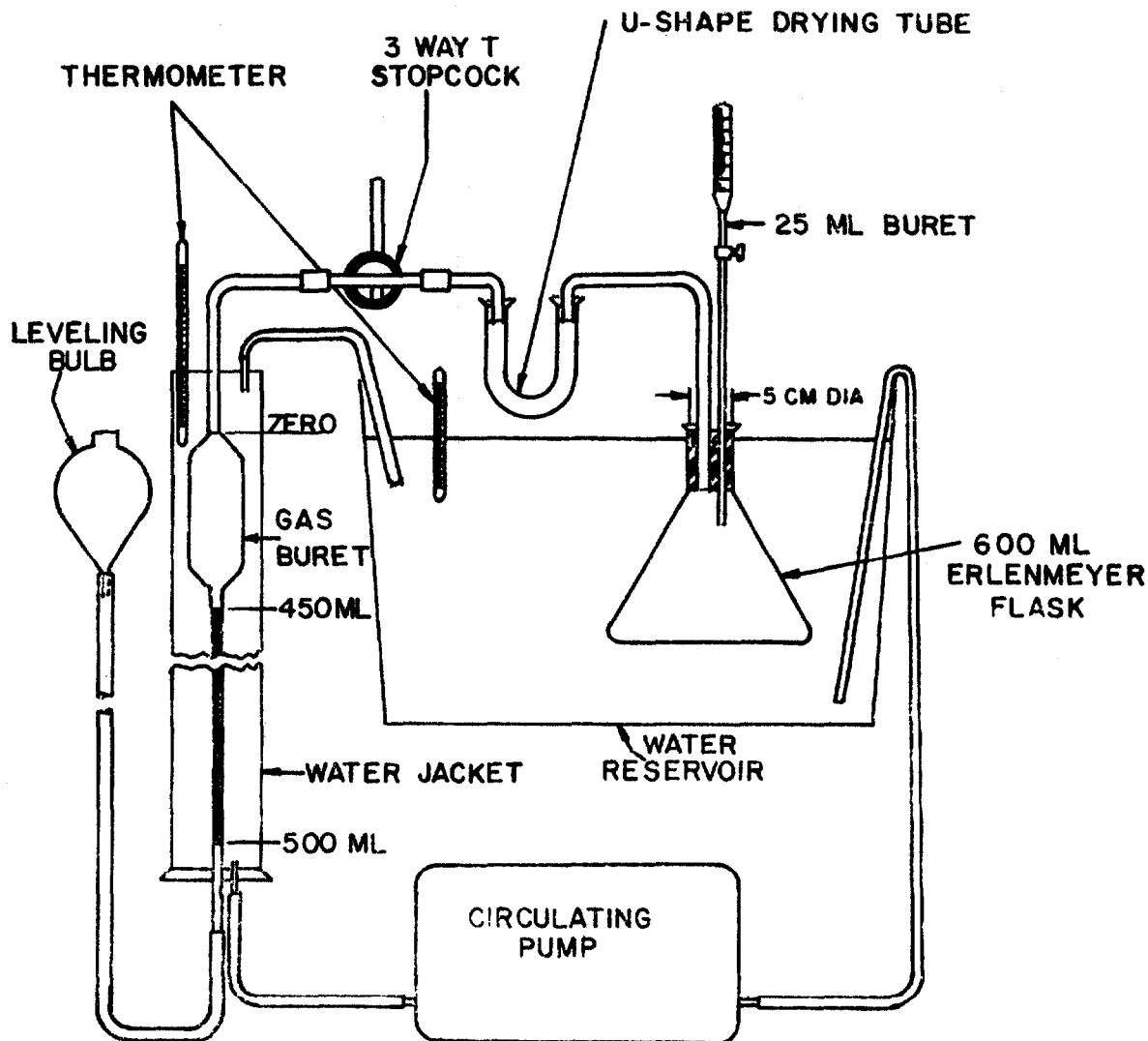

Fig ASSEMBLY FOR EUDIOMETER METHOD

level;

C = atm pressure in mm;

D = vapor pressure of w at temp of test;

t = temp at which the determination is made (usually 25°);

W = wt of dry sample

d) *Calcium Resinate*. Transfer a 2 g dry sample to a tared medium-porosity sintered glass crucible and accurately weigh. Extract with six 5-ml portions of chlf in the same manner as described under opn c). After removing the last traces of chlf by suction, dry the crucible and contents at 135°±2° for 1 hr,

cool in a desiccator and weigh. Save the crucible with residue for the next opn

$$\text{Percent of Calcium Resinate} = \frac{100(A-B)}{W}$$

where: A = wt of crucible and sample before extraction with chlf;

B = wt of crucible and residue after extraction; and

W = wt of dry sample

e) *Graphite*. Transfer the crucible with residue saved after opn d) to a 250-ml beaker, add 150 ml of 5% AcOH soln and cover the beaker

with a watch glass. Place on a hot plate and heat to boiling. Break up any undissolved lumps by means of a flattened end of a glass rod. Remove the beaker from the hot plate. Lift the crucible by means of stainless steel tongs, empty it into the beaker and wash back quantitatively any adhering particles of graphite, using a stream of hot w from a wash bottle. Connect the same crucible to the suction flask and filter the contents of the beaker, while still hot, transferring to the crucible by means of hot w stream, any graphite adhering to the walls and bottom of beaker. Wash the graphite in crucible with three 20-ml portions of hot 2N hydrochloric acid, followed by three 20-ml portions of hot 8N nitric acid, and, finally, with three 20-ml portions of hot distd w. Remove the crucible, dry it at 100° for 1 hr, cool in a desiccator and weigh

$$\text{Percent of Graphite} = \frac{100(C-D)}{W}$$

where: C = wt of crucible & residue after extraction with acids;
D = wt of empty crucible; and
W = wt of dry sample

Method No 220. *Tracer R-45* (using Igniter K-29, described under Method No 219). Same Specs as listed under Method No 219 gives its composition as: Strontium Nitrate (anhydrous) 56.0±2.0, Magnesium - Aluminum Alloy (powdered) 37.0±2.0 & Polyvinyl Chloride 7.0±1.0%

Procedures:

a) *Moisture*, max 0.10%. Use 5 g sample and proc a) given under Method No 219
b) *Polyvinyl Chloride*. Transfer an accurately weighed 1 g of dry sample to a 250-ml beaker, add ca 100 ml of reagent-grade methyl-ethyl ketone, cover the beaker with a watch glass and transfer to a steam bath. Heat for 1 hr with occasional stirring, remove from the steam bath, decant the supernatant liquid and filter it thru a tared medium-porosity sintered glass crucible. Transfer quantitatively the residue in beaker into the same crucible, using a stream of methyl-ethyl ketone (ca 50 ml). Air-dry the crucible with residue by aspiration, heat it in an oven at 105°±5° for 1 hr, cool in a desiccator and

weigh. Save the crucible with residue for the next opn

$$\text{Percent of Polyvinyl Chloride} = \frac{100(A-B)}{W}$$

where: A = wt of the crucible with dry sample before extraction;
B = wt of the crucible with residue, after extraction; and
W = wt of dry sample

c) *Strontium Nitrate*. Leach the residue in crucible left after opn b) with several successive 10-ml portions of w, cooled to 10°, until all Sr nitrate has been removed. Test the completion of extraction by treating one drop of filtrate placed on a white spot plate with one drop of 1% diphenylamine soln in 36N sulfuric acid. The absence of a blue coloration shall indicate the complete removal of Sr nitrate. Dry the crucible with residue of Mg-Al alloy at 135°±2° for 1 hr, cool in a desiccator and weigh

$$\text{Percent of Sr(NO}_3)_2 = \frac{100(B-C)}{W}$$

where: B = wt of crucible with residue after extraction with methyl-ethyl ketone;
C = wt of crucible with residue after leaching with w; and
W = wt of dry sample

d) *Magnesium-Aluminum Alloy* (powdered). It can be calcd by subtracting from 100% the combined percentages of PVC & Sr(NO₃)₂ or from the equation:

$$\text{Percent of Mg-Al Alloy} = \frac{100(C-D)}{W}$$

where: C = wt of crucible with residue after leaching with w;
D = wt of empty crucible; and
W = wt of dry sample

Lusardi (Ref 24) describes in Section 300 analytical procedures for the following compositions used in pyrotechnics: igniter, first fire, flash, matchhead, delay and relay:
Method No 320. Igniter Composition, Aircraft Signal Type - Red lead 33-1/3, CuO 33-1/3 & Si 33-1/3 [US Army Spec No 50-55-9 (1946)]
Method No 321. Igniter Composition K29. Type 1 - Ba peroxide 81.0, Mg powder 17.0 & Ca resinate 2.0% [PA-PD-9 (Amend 1)]

(1952)]; Type II - Ba peroxide 80.5, Mg powder 16.5, Ca resinate 2.0 & graphite 1.0% [PA-PD-9(Rev 1)(1954)]

Method No 322. Igniter Composition M1A1 - DADNPh, (Diazodinitrophenol), NS (Nitrostarch), wood charcoal (powder) & K chlorate (percentages are not given) [MIL-S-10641 (Ord)(1950)]

Method No 323. Igniter Composition M31 - Pb thiocyanate 45.0 & K chlorate 55% [MIL-C-11233(Ord)(1951)]

Method No 324. Igniter Composition (Mg-KNO₃ Type) - Mg (powder) 46.0, K nitrate 52.0 & Et cellulose 2.0% [PicArnsGenLabRept 57-HI-80(1957)]

Method No 325. Ignition Powder, Non-Gaseous, Type II - Red lead oxide 84.0, Si 15.0 & glycerin 1.0% [PXS-1039(Rev 2)(1946)]

Method No 309. First Fire Compositions: Type I - Ba nitrate 50.0, TeNCbz (Tetra-nitrocarbazole) 10.0, Si 20.0, Zr hydride 15.0 & Laminac 4116 + 1% Lupersol DDM 5.0%

Note: Lupersol DDM catalyst is a 60% soln of ethyl methyl ketone peroxide in dimethyl-phthalate. Type II - Sr nitrate 50.0, TeNCbz 10.0, Si 16.0, Zr hydride 15.0, PVC (polyvinyl chloride) 5.0 & Laminac 4116 + 1% Lupersol DDM 4.0%; Type III - Ba nitrate 50.0, TeNCbz 10.0, Si 13.0, Zr hydride 20.0, PVC 3.0 & Laminac 4116 + 1% Lupersol DDM 4.0%

Method No 312. Flares, Igniting M113 & M114 use First Fire Composition contg BkPdr (Black Powder) 25 & Igniting Composition 75%; Igniting Composition consists of Mg 48.5, K perchlorate 48.5 & Bakelite Resin No 4036 3.0% and Illuminant Compositions: No 1 - Sr nitrate 47.0, Mg 47.0, PVC 4.0 & linseed oil 2.0% or No 2 - Sr nitrate 50.0, Mg 30.0, Ti dioxide 10.0, PVC 6.0, castor oil 2.0 & linseed oil 2.0 [MIL-F-13190(1954)]

Method No 317. Flare, Trip M48 uses First Fire Composition contg Mg 30.00, Al 6.75, Ba nitrate 27.75, Na oxalate 9.00, K nitrate 18.50, S 2.60, charcoal 3.90, castor oil 0.75 & linseed oil 0.75% [PicArnsGenLabRept 55-HI-459(1955)]

Method No 318. Flare, Trip M49 uses First Fire Composition contg Al 15.75, Ba nitrate 51.00, K nitrate 18.50, Na oxalate 3.75, S 5.60, charcoal 3.90 & castor oil 1.50%

[PicArnsGenLabRept 80210(1942)]

Method No 328. Matchhead Composition - Sb sulfide, red P & charcoal (percentages are not given) [PA-PD-426(1952) superseded by MIL-S-10522H(MU)(1968), Amendment 1 (1969)]

Method No 332. Scratcher Composition - Sb sulfide, K chlorate & dextrin (percentages are not given) [MIL-S-10522H(MU)(1968)]

Method No 334. Signal Distress, Red Star uses First Fire Composition contg Mg 18.70, Sr nitrate 23.10, K perchlorate 14.50, K nitrate 23.90, S 3.40, charcoal 5.0, asphaltum 5.10, HCB (hexachlorobenzene) 4.40 & graphite 1.90% [PicArnsGenLabRept 55-HI-1440(1955)]

Method No 303. Delay Composition for the M127 (T73) Ground Signal - K nitrate 60.84, Sb sulfide 20.00, S 13.66, dextrin 3.00 & charcoal 2.50% [PA-PD-244(1952) superseded by OAC-PD-54(1957)]

Method No 304. Delay and Fuze Compositions. Delay Composition for Parachute Red Star Distress Signal M131 (T66E1) and Fuze Composition for Parachute Aircraft Flare M9A2 consist of K nitrate 71.8, S 10.1, charcoal 15.1 & carnauba wax 3.0% [PicArnsGenLabRept 55-HI-80(1955)]

Method No 305. Delay Powders (Barium Chromate-Boron Types). Type I - Ba chromate 90 & B 10%; Type II - Ba chromate 95 & B 5% [PicArnsGenLabRept 56-HI-1670(1956)]

Method No 306. Delay Powder, Non-Gaseous (Type I, Class A - Lead Chromate Delay Powder) - Pb chromate 89.0, Si 10.0 & linseed oil 1.0% [PXS-1039(Rev 2)(1946)]

Method No 307. Delay Powder, Non-Gaseous (Type I, Class B - Barium Chromate Delay Powder) - Ba chromate 74.5, Mn 22.0 & S 3.5% [PXS-1039(Rev 2)(1946)]

Method No 308. Delay Powder, Non-Gaseous (Zirconium-Nickel Alloy Type): Type I (delay 2-sec) - Ba chromate 60.0, 70/30 Zr-Ni alloy 26.0 & K perchlorate 14.0%; Type II (5-sec delay) - Ba chromate 60.0, 70/30 Zr-Ni 9.0, 30/70 Zr-Ni 17.0 & K perchlorate 14.0%; Type III(12-sec delay) - Ba chromate 60.0, 70/30-Zr/Ni 3.0, 30/70-Zr/Ni 23.0 & K perchlorate 14.0% [PA-PD-23(Rev 1)(1953)]

Method No 330. Relay Powder, Non-Gaseous (Type II, Class A) - K perchlorate 51.0, Ni 15.1, Ti 29.1 & infusorial earth 4.8% [AXS-1277 (Rev 1 & Amend 1) (1945)]

We are not including here analytical procedures for the above compositions

This Section 8 was reviewed by Mr Nathan Liszt of PicArSn

Refs: 1) M. Marquoyrol & P. Loriette, MP **18**, 93-5 (1921) (Analysis of an unknown sample of an initiating mixture by the method used in the Laboratoire Centrale des Poudres, Paris, France) (Abstracted in Vol 1 of Encycl, p A580-R)

2) A. Langhans, SS **16**, 41-3, 48-52 & 57-9 (1921); CA **15**, 2985 (1921) (Investigation of primer and detonator compositions)

3) C.A. Taylor & W.H. Rinckenbach, "Analysis of Detonating and Priming Mixtures", USBurMinesTechPaper **282**, USPrtgOff, Washington, DC (1922), pp 9-11 (Materials of detonating compositions); 11-12 (Structure of detonators); 12-13 (Method of removing charges from detonators); 13-14 (Sampling of detonator materials); 14-21 (Methods of analysing detonating mixtures which include: MF & K chlorate; MF, K chlorate & Tetryl; MF, K chlorate & TNT; and MF, K chlorate, HNMnt & NC); 21-2 (Analysis of priming charges in detonators, which include: MF & NC, loose MF & K chlorate; K chlorate & PA; Pb nitrate & Tetryl; and Pb nitride & TNT); 22-3 (Nature of priming compositions); 23-5 (Primer composition materials); 25 (Sampling of primer materials); 25 (Identification of primer materials); 26-7 (Analysis of single primers); 27-33 (Analyses of typical priming mixtures, which include: MF, Sb sulfide, K chlorate & glass; K chlorate, Sb sulfide, Pb sulfocyanate & TNT; Pb picrate, red P & Ba nitrate; K chlorate, Sb sulfide, Pb nitrate & TNT; K chlorate, Sb sulfide, Pb nitrate, TNT & glass; MF, Pb picrate, Sb sulfide, Ba nitrate & Ba chlorate; Ag permanganate, Sb sulfide, TNT & red P; and MF, Sb sulfide, Ba nitrate, PA & glass)

4) M. Tarle, SS **23**, 51-3 (1928) (Testing of detonating caps)

5) Reilly (1938), pp 61-3 (Detonator composi-

tions); 63-4 (Percussion cap compns)

6) W. Taylor, Chem & Ind (London), **1939**, 1065-69 (Modern detonators)

7) R.L. Grant & A.B. Coates, "Safe Opening and Determination of Construction of Detonators", USBurMines **RI 3594** (1941), p 6 (Sampling of detonators); 6-9 (Opening of detonators); 10 (Removing the metal and examining the bridge); 10-11 (Details in determination of construction of detonators); and 11-12 (Methods of measurement of detonators)

8) Kast & Metz (1944), pp 489-99 (Analytical procedures for MF, LA, LSt & Tetracene); 499-509 [Analyses of priming and detonating mixts, which include: MF, K chlorate & TNT (or Tetryl); LA & TNT; MF, K chlorate, HNMnt & NC; MF, Sb sulfide, K chlorate & powdered glass; MF (or LA), Ba nitrate (or Ba peroxide), Sb sulfide, TNT & glass; K chlorate, Sb sulfide, Pb sulfocyanate & TNT; Pb picrate, red P & TNT; Pb nitrate, K chlorate, Sb sulfide & TNT; and MF, Sb sulfide, Ba nitrate, PA & glass ; 524-35 (Analyses of pyrotechnic compositions and of their ingredients)]

9) J.J. Lingane, "Polarographic Analysis of Primers", OSRD Rept **4881** (1945) (PBL 30765)

10) Pérez Ara (1945), pp 713-71 (Chem analyses of expls, including initiating expls)

11) Vivas, Feigenspan & Ladreda, Vol 2 (1946), pp 305-330 (Initiating expls and their analyses); 352-67 (Priming mixts); 367-70 (Pyrotechnic mixts)

12) Stettbacher (1948), pp 95-104 (Initiating expls and their analyses)

13) Izzo, Pirotecchia (1950), 245-57 (Chemical analyses of pyrotechnic compositions)

14) Stettbacher, Pólvoras (1952), pp 124-33 (Initiating expls and their analyses)

15) Belgrano (1952), pp 199-246 (Initiating expls and their analyses)

16) Anon, "Military Explosives", **TM 9-1910** (1955), pp 93-118 (Initiating agents and priming compositions) (New edition is listed as Ref 35)

17) Bofors, "Analytical Methods for Powders and Explosives", A.B. Bofors, Nobelkrut, Bofors, Sweden (1960), pp 210-18 (Primary

- expls LA, LSt, MF, AgA, Tetracene and Their Analyses)
- 18) Encyclopedia 1 (PATR 2700) (1960), pp A74 to A76 (Analytical Procedures for Copper Acetylde); A563 to A567 (Lead Azide, Plant Analytical Procedures); A567 to A573 (LA Analytical Procedures by US Military Specification Methods); A575-R (Laboratory Test for the Presence of LA); A576 to A580 (Listing of Typical Lead Azide Primer and Detonator Compositions); A580 to A584 (Analysis of Mixtures Containing LA, Sb sulfide, Pb sulfocyanate and K chlorate by Methods 1 and 2); A584 to A585 [Analysis of Mixtures: LA, K chlorate, Sb sulfide & carborundum (or glass)]; A585 to A586 (Analysis of Mixtures: LA, K chlorate, Sb sulfide, glass & shellac); A586 to A587 (Analysis of Mixture: LA, Ba nitrate, Basic LSt, Sb sulfide & Tetracene); A612 to A617 (Sodium Azide, Plant Analytical Procedures); A617 to A619 (Analytical Procedures for Technical Sodium Azide)
- 19) Y. Wakazono, Suiyokaishi **14**(7), 341-4 (1961) & **14**(10), 566-71 (1962); CA **61**, 14456 (1964) (Analytical procedures for detonator delay compositions)
- 20) Encyclopedia 2 (PATR 2700) (1962), pp B176 to B177 (Analytical Procedures for Black Powders, including those used in fuses and fuzes); B343 to B346 (Burning Characteristics of Explosives, Including Experimental Procedures); B355 to B366 (Burning Characteristics of Pyrotechnic Compositions); C50 (Analytical Procedures for Tetranitrocarbazole); C191 & C192 (Composition of K chlorate mixtures); C193 to C197 (Analytical Procedures for Potassium Chlorate and Its Mixtures); C199 to C200 (Analytical Procedures for Sodium Chlorate)
- 21) Military Standard, "Explosive: Sampling, Inspection and Testing", **MIL-STD-650** (1962), Method 401.1 (Antimony sulfide by K bromate method); 407.1 (LA by endiometer method); 408.1 (LSt, Normal by spectrophotometric method); 410.1 (MF) and 416.1 (Tetracene)
- 22) D.W. Traas & H.L. Lichtenberg, Chem & Ind (London) **1962**, 2040 & CA **58**, 3262 (1963) (Polarographic estimation of Tetracene in percussion caps contg as other ingredient LSt)
- 23) Military Standard, "Pyrotechnics: Sampling, Inspection and Testing", **MIL-STD-1234** (1962 to 1967): Chemical Test Methods for Chlorates (402.1); Lead Sulfocyanate (405.1); Antimony Sulfide (410.1)
- 24) A.R. Lusardi, "A Manual of Laboratory Procedures for the Analysis and Testing of Explosives and Pyrotechnics", Picatinny Arsenal, Dover, NJ, Sections 100 & 200 (1962): US Military Specification Requirements and Testing of DAzDNPh (Diazodinitrophenol) (Method 102); LA (Lead Azide) (109); LSt (Lead Styphnate), Basic (110); LSt, Normal (111); MF (Mercuric Fulminate) (112); Specification Tests of Multiple Component Primer Compositions) (Methods 201 to 212)
- 25) Ibid, Section 300 (1962), "Specification Tests of Pyrotechnic Compositions" (Methods 301 to 340)
- 26) Ibid, Section 400 (1963), "Specification Tests of High Explosives"
- 27) Ibid, Section 500 (1963), "Chemical and Physical Tests"
- 28) Ibid, Sections 600 & 700 (1963), "Precipitation Methods and Volumetric Methods"
- 29) Ibid, Sections 800 & 900 (1963), "Qualitative Methods. Preparation and Standardization of Solutions"; Detection of Azides (Method 802.4); of Chlorates (802.8); of Tetracene (802.11); of Mercury (802.15) and of Thiocyanate (802.29)
- 30) Std Methods Chem Analysis, **2B** (1963), pp 1345-47 (Qualitative tests for initiating expls: LA, MF, DAzDNPh, LSt & Tetracene); pp 1365-70 (Analyses of expl mixts of detonators and primers)
- 31) A.M. Wild, Chem & Ind (London), **1963** (20), 819-20 & CA **59**, 3710 (1963) (Polarographic estimation of Tetracene, LSt & LDNR in single caps contg mixts of these ingredients)
- 32) G. Norwitz, Microchem J **7**(1), 19-28 (1963) & CA **60**, 13089 (1964) (Semimicro colorimetric determinations of inorganic nitrates in expl mixtures, including those

contained in primers, incendiaries and tracers)

33) Giorgio (1964), pp 162-63 (Initiating mixtures)

34) Encyclopedia 3 (PATR 2700) (1966), pp C275 to C288 (Chromates and Dichromates, Including Their Analytical Procedures); C411 to C417 (Analytical Procedures Based on Color Reactions. Rapid Method of Identification of Common Explosive Compounds and of Explosive Mixtures); C608 to C610 (Analytical Procedures for HMX); C625 to C626 (Analytical Procedures for RDX)

35) Anon, "Military Explosives", TM 9-1300-214/TO 11A-1-34 (1967), pp 7-1 to 7-19 (Initiating Agents and Their Testing); 12-1 to 12-2 (Identification of Initiating Explosives)

Section 9 PHYSICAL TESTS FOR DETERMINING EXPLOSIVE AND OTHER PROPERTIES OF DETONATORS, PRIMERS, IGNITERS AND FUZES

The tests which are described in Vols 1, 2 & 3 of this Encyclopedia are not repeated here except those which were described too briefly. The tests already described are listed here under Refs 30, 32 & 41

Determination of moisture content is described in Section 8, "ANALYTICAL PROCEDURES, ETC", where are listed numerous US Military Specifications. These specs contain also a brief description of required physical tests. Before describing the specification requirement tests, a résumé is given of "Measuring Techniques" of fuze explosive components, as discussed in NOLTR 1111 (1952), pp 9-1 to 9-56 (Ref 11)

The measurement of fuze component performance consists mainly of a determination of (a) the input characteristics, and (b) the output characteristics

In general, *input characteristics* may be considered synonymous with *sensitivity* ("sensitiveness"). Sensitivity measurements are usually concerned with the energy

required to insure initiation of the explosive component. This energy may be supplied in mechanical, electrical or thermal form, and must be measured without undue disturbance of the firing system or appreciable energy consumption by the measuring device

Output Characteristics embrace all the physical phenomena which may result from an explosion. Since an expln may deliver heat, light and sound as well as mechanical energy in the form of high-pressure waves, high-velocity gases and high-velocity particles, the particular aspect of the energy output that must be measured often depends greatly on the application of the component. Thus in a detonator application, it may be most important to determine the intensity of the shock wave delivered to the succeeding "lead" or "booster"; while in certain primers, the ability to drive a small piston may be the primary consideration

A few miscellaneous tests that fall under neither input nor output characteristics, are surveillance tests, delay times, waterproofness, workmanship, duds, tumbling and some others

The principal input and output tests used by the US at the time of publishing NOLTR 1111 (1952) included: Drop Ball Testers (two types); Sand Bomb Apparatuses 100, 200, 360 & 500 gram; Condenser Discharge Apparatus; Torsional Ballistic Pendulums (two types); Drop Ball Test Set Mk 135 with Chronograph & Thermocouple; Drop Ball Test Set Mk 136 with Chronograph; Gas Explosion Chambers (two types); Gas Volume and Impulse Apparatus; Pressure Bomb Apparatus and Hopkinson Bar Apparatus (Ref 11, pp 9-2 & 9-3, Table 9-1)

Sensitivity (Sensitiveness) Measurements

Accdg to Ref 11, pp 9-28 to 9-30, the sensitivity tests are usually performed for one or more of the following purposes:

(a) to determine the energy the preceding firing train component must deliver to insure that the train does not fail; (b) to measure the extent of variation in manuf for quality control & specification purposes, and (c) to measure the deteriora-

tion resulting from storage under various conditions

In the measurement of sensitivity, it is desired that the tests afford the maximum certainty for the few samples expended, regardless of the purpose of the test (although the test purpose may det the maximum sample size which may be economically used).

If in the conventional drop test method, the sample fails to detonate, there is no indication whether the sample failed by a large or small margin and, similarly, when the sample detonates there is no clue as to whether it might have fired with half the energy applied. More precise measurements can be obtd by using the *staircase method*, developed during WWII at Bruceton (Pennsylvania) testing station of the US Bureau of Mines. In this method, the severity of each successive test is detd by the success or failure of the preceding test. In starting the test, an effort is made to make the 1st fall somewhere in the vicinity of the expected 50% firing height. If a failure occurs on the 1st fall, the next sample is tested at one unit greater height and if the 1st fall produces a fire, the next sample is tested one unit lower. The test continues in this manner, height increasing after a failure and decreasing after a fire, until all the samples (minimum number is 50) have been tested. The increment of height designated as one unit is usually 0.5 or 1 inch, depending upon the expected standard deviation (σ) of the lot, it being desired to fire in steps of ca 0.5 to 1 times σ . Calculation of the 50% height σ is then performed according to the procedure of Natrella (Ref 42a)

Procedure. Count the total number $R = \sum r_i$ of responses, and let $N = \sum n_i$ be the total number of objects tested. If $R \leq \frac{N}{2}$, perform steps (1) thru (6); if $R > \frac{N}{2}$, perform steps (1') thru (6'). The distance between two successive levels is d.

When $R \leq \frac{N}{2}$:

- (1) Prepare a four-column table with columns headed y, r, j, j^2 .

- (2) Let: y_0 = the lowest level at which a "response" occurred
 y_1 = the level one step above y_0
 y_2 = the level two steps above y_0
 y_k = the highest level at which a "response" occurred

Enter y_0, y_1, \dots, y_k in column y .

- (3) In column r , corresponding to each y_j , enter r_j = the number of "responses" at level y_j
 (4) Enter the numbers 0, 1, ..., k , in column j
 (5) Corresponding to each entry in column j , enter its square in column j^2
 (6) Compute:
 $A = \sum j r_j$, the sum of products of corresponding entries in columns r and j
 $B = \sum j^2 r_j$, the sum of products of corresponding entries in columns r and j^2

$$m = y_0 + d \left(\frac{A}{R} - \frac{1}{2} \right)$$

$$s = 1.620d \left(\frac{RB - A^2}{R^2} + .029 \right)$$

When $R > \frac{N}{2}$:

- (1') Prepare a four-column table with columns headed $y, n-r, j, j^2$
 (2') Let: y_0 = the lowest level at which "no response" occurred
 y_1 = the level one step above y_0
 y_2 = the level two steps above y_0
 y_k = the highest level at which "no response" occurred.
 Enter y_0, y_1, \dots, y_k , in column y
 (3') In column $n-r$, corresponding to each y_j , enter $n_j - r_j$, the number of "no response" at level y_j
 (4') Enter the numbers 0, 1, ..., k , in column j
 (5') Corresponding to each entry in column j , enter its square in column j^2
 (6') Compute:
 $A = \sum j (n_j - r_j)$, the sum of products of corresponding entries in columns $n-r$ and j
 $B = \sum j^2 (n_j - r_j)$, the sum of products of corresponding entries in columns $n-r$ and j^2

$$m = y_0 + d \left(\frac{A}{N-R} + \frac{1}{2} \right)$$

$$s = 1.62d \left\{ \frac{(N-R)B - A^2}{(N-R)^2} + .029 \right\}$$

m is an estimate of the mean (and the 50th percentile) of the distribution of critical levels

s is an estimate of the standard deviation of the distribution of critical levels

T.W. Anderson et al, NAVORD Rept 65-46 (1946) described seven varieties of "staircase" method including the Bruceton test. Natrella (Ref 42a) also gives several References to other discussions of the up-and-down or staircase method of testing

The Bruceton test affords a fairly good estimate of the 10, 50 and 90% firing points for minimum trials, but depends heavily on the assumption that the sample sensitivity follows a normal distribution about the median firing height

Where large samples are available, the Frankford *rundown* procedure affords a simple method. This requires that a fixed number of trials be made at each of a succession of drop heights which span the range from no-fire to all-fire. The percentage fired at each height is then plotted as a function of height, and the height for any desired percentage of firing may then be obt'd by interpolation. Some preliminary information as to the approx no-fire and all-fire heights is necessary in order to properly space the various height levels, but this may be readily obtainable from a Bruceton run or from prior experience. The method was described by C.W. Churchman in the Frankford Arsenal Laboratory Rept No R-259A (1943)

The following sensitivity measurements of detonators and primers are described in Ref 11, pp 9-4 to 9-28

a) *Sensitivity Measurements of Stab Detonators*, pp 9-4 to 9-7. Fig 9-1, p 9-5 (our Fig 1) gives a photographic view of a

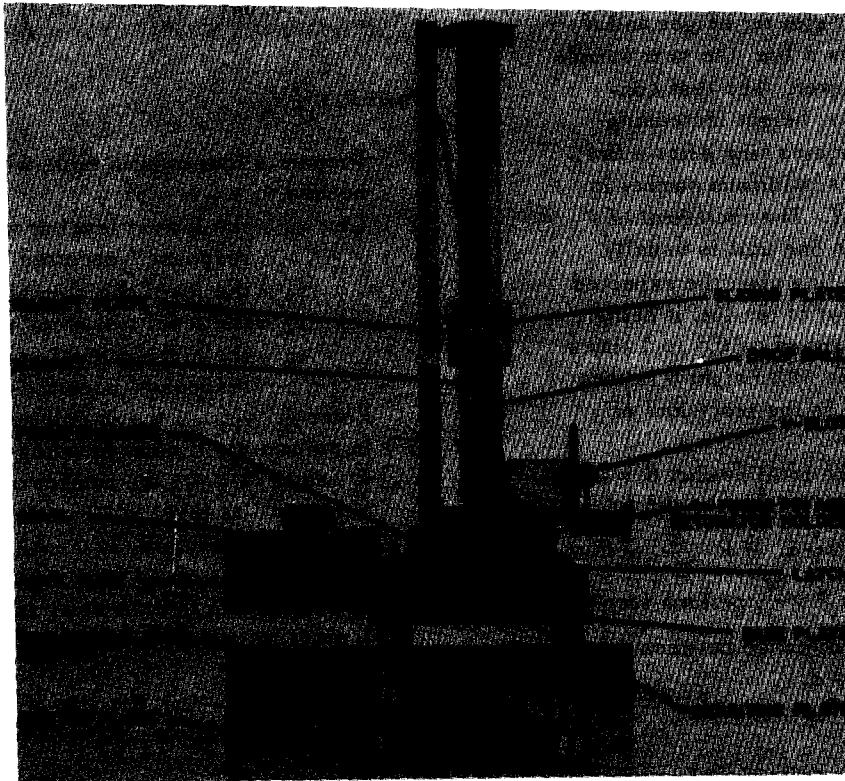

Figure 1 Test Set Mk 136 Mod 0 for Stab Primers and Stab Detonators

"Drop-Ball Apparatus", known as "Test Set Mk 136Mod0", which is applicable for testing detonators and primers. In this apparatus the initiating energy is supplied by the impact of a freely falling steel ball upon a firing pin which rests lightly against the detonator (or primer). The total energy of the ball at contact is equal to its weight multiplied by the height from which it has fallen. The test sample is mounted in a plastic holder on top of a precisely located steel anvil. A heavy shield surrounds the anvil and the plastic holder. A small opening in the upper surface of the shield is accurately aligned with the plastic holder so that the firing pin may be inserted in the tubular part of the holder above the test sample after the shield has been closed. The upper end of the firing pin protrudes slightly above the shield. The steel drop ball is held by an electromagnet that may be raised or lowered by a jack screw. Accurate alignment of the ball with the axis of the firing pin is secured by a concave bottom of the magnet. [Compare with Fig 6, p 10 of PATR 2299(1956) (Ref 21). The firing pin and the plastic holder are discarded after firing. The test procedure may follow in firing either the Bruceton or the Frankford method

b) *Sensitivity Measurements of Electric Detonators*, described on pp 9-7 to 9-12 & 3-36 of Ref 11, include the "condenser discharge" and the "constant current" method. With either method the operating procedure may follow the Bruceton or the Frankford firing schedule to obtain the desired information. With both methods the aim is to measure the electrical energy input necessary to bring the ignition bridge up to the initiation temp of the expl to test. Since a bridge wire of given dimensions and material must reach a definite temp in order to initiate the expl in which it is imbedded, it is evident that the rate of energy input is an important consideration. Thus a bridge wire may reach thermal equilibrium with its environment at a temp well below the initiation temp if the rate of energy input is low, and therefore a large total energy

may be delivered without initiation

A complete discussion on bridge wires and the testing of electric detonators is given in Ref 11, where also are shown photographic views of test equipment (Figs 9-3, 9-4 & 9-5)

c) *Sensitivity Measurements of Flash Detonators*, described in Ref 11, pp 9-12 to 9-17, include the following methods: (1) initiation of detonator by means of flame produced by a primer; (2) immersion in a bath of molten Wood's metal or solder and maintaining at a constant temp until detonation. The time to detonation is measured as an inverse function of sensitivity; (3) initiation by blow torch flames of various intensities; and (4) by flash sensitivity measurement method with Test Set Mk174-Mod0, developed at the US Naval Ordnance Laboratory

The following Navy test was considered as an apparently successful approach to flash sensitivity measurements. The test apparatus consists of a heavy firing chamber into which the sample detonator is sealed along with a charge of stoichiometric H_2-O_2 gas mixture at a known initial pressure. Then the gas is ignited by a spark plug and if the initial pressure is high enough, a successful detonation of the sample is obtd. By varying the initial gas pressure over a range of values, it is possible to vary the initiation of samples from 0 to 100% along a very smooth curve. A photographic view of this "Oxy-Hydrogen Flash Detonator Tester Mk174Mod0" is given in Fig 9-7, p 9-16 and its detailed view in Fig 9-8, p 9-18. A more complete description of the test is given by C.J. Zablocki & F.W. Hayward in NOLM 10401(1949)

d) *Sensitivity Measurements of Stab Primers*, described in Ref 11, pp 9-17 & 9-20 to 9-22, are essentially the same as those used for "stab detonators". The apparatus used for testing is "Test Set Mk136Mod0" (See our Fig 1)

e) *Sensitivity Measurements of Percussion Primers*, described in Ref 11, pp 9-21 to 9-27, use drop-ball apparatus, called "Test Set Mk135Mod0" shown in Fig 9-11, p 9-22

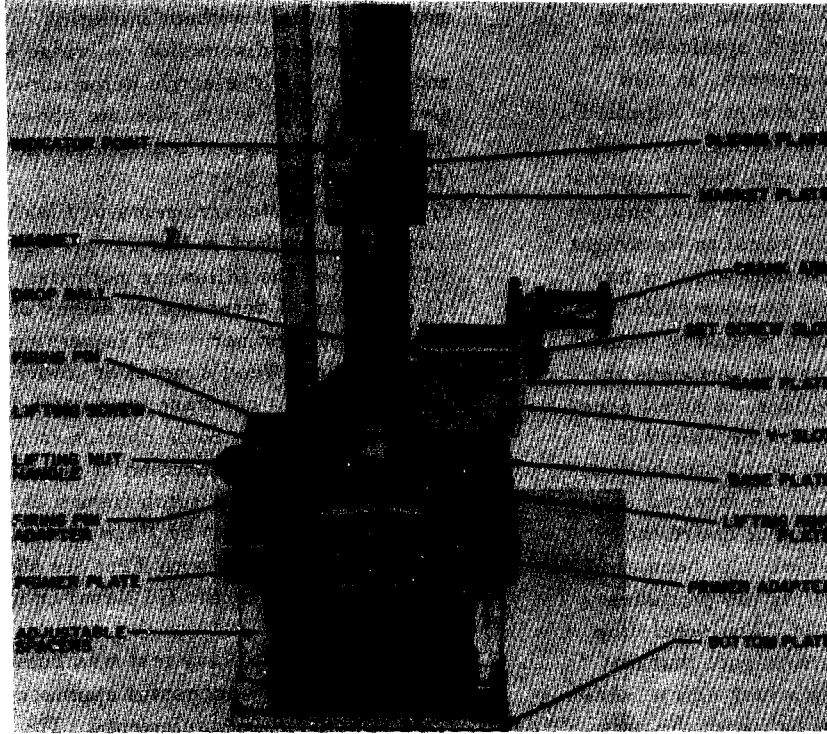

Figure 2. Test Set Mk 135 Mod 0 for Percussion Primers

and reproduced here as Fig 2. The app is similar to Test Set Mk136Mod0 previously described, except for the lower structure which houses the sample. In Test Set Mk135, the sample primers are mounted in individual holders which are inserted into appropriate recesses in a six-position turntable, so designed that each of the six indexed positions brings a primer (in its holder) directly below the standard firing pin. When everything is in readiness for firing, the pin is lowered into contact with the center of the primer cup and the drop ball released by disconnecting power from the electromagnet.

Another apparatus, known as "Test Set Mk173Mod0, developed ca 1949 was described by H.W.L. Street in NOLM 10398. It is described on pp 9-23 to 9-26 and shown in Fig 9-12 of Ref 14 (our Fig 3). The apparatus utilizes the mechanical structure of Test Set Mk135Mod0 but also includes an electronic chronograph and appropriate fittings to permit measurements of firing delay times. The app is also equipped with features for comparative heat output

measurements, which are described on pp 9-46 & 9-47 of Ref 14

When the drop ball of Test Set Mk173-Mod0 strikes the firing pin, an electronic timer or chronograph is started and it is stopped when flame issues from the primer. The time interval so measured is made up of three portions, namely: (1) the penetration time of the firing pin from drop ball impact to mixture initiation; (2) the time from mixture initiation to first emission of reaction products; and (3) the flame transit time from primer to pick-up device. The sums of intervals (1) and (2) is the important variable for the purposes of this test, whereas the flame transit time is approx constant for a given type of primer and explosive. To a fairly good first approximation, the energy delivered to the expl mixture in a particular type of primer must be proportional to the depth of indentation produced by the firing pin as a result of the drop ball impact. The time required to initiate the primer, that is, the time required to produce sufficient indentation to

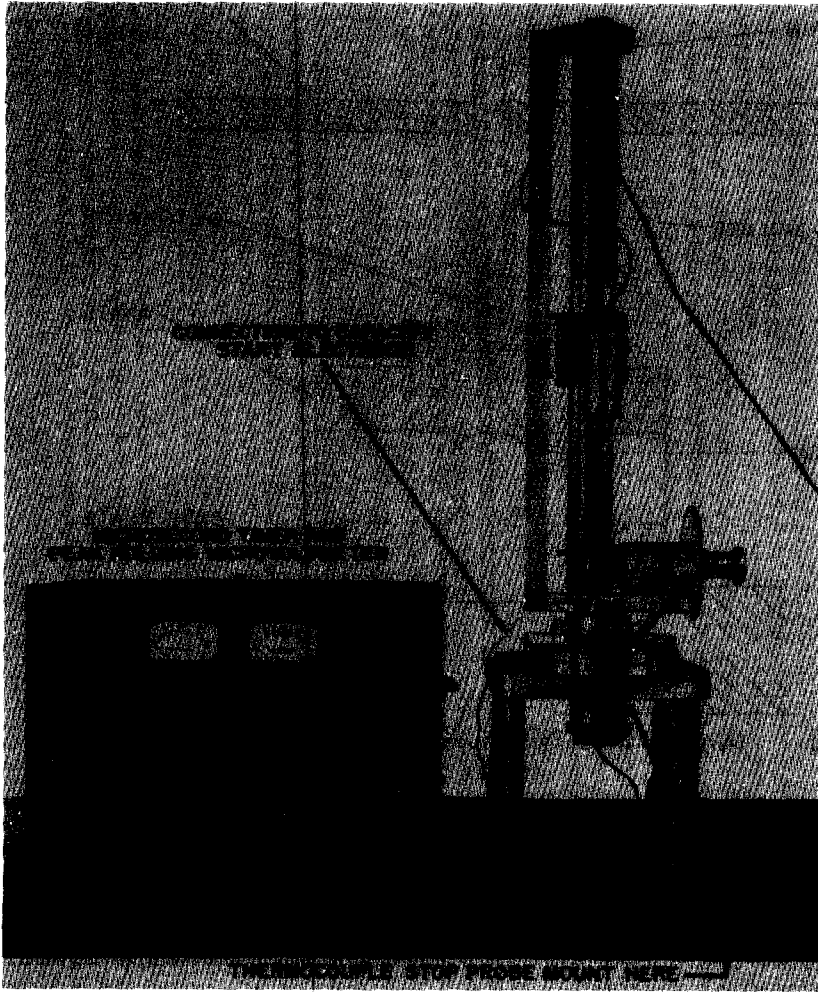

Figure 3 Test Set Mk 173 Mod 0 for Percussion Primers

deliver threshold firing energy to the explosive mixture, will thus be a function of the impact velocity of the drop ball and, therefore, will be long when the drop ball is released from a small height, and short when the drop ball release height is great. On the other hand, for a given drop ball impact velocity, the firing time will vary inversely as the primer sensitivity, since the more sensitive the primer mixture, the smaller the indentation required for firing. Thus, if firing times are measured at a given drop height on successive samples of primers during surveillance, it is found that as the primer sensitivity deteriorates, longer and longer initiation delay times are recorded.

Such a test could be conducted at the all-fire point of the deteriorated primers, thus obtain sensitivity data without any need for misfiring half of the sample group, as must be done in the "staircase" sensitive tests.

Another device for investigating percussion primer sensitivity is the Piezo-Electric Impulse Gage described by L. Zernow, Aberdeen Proving Ground, BRL Rept No 84 (1942). A brief description is given in Ref 14, p 9-27.

f) *Sensitivity Measurements of Electric Primers*, described in Ref 14, pp 9-27 & 9-28, are similar to those for electric detonators described here as item (b).

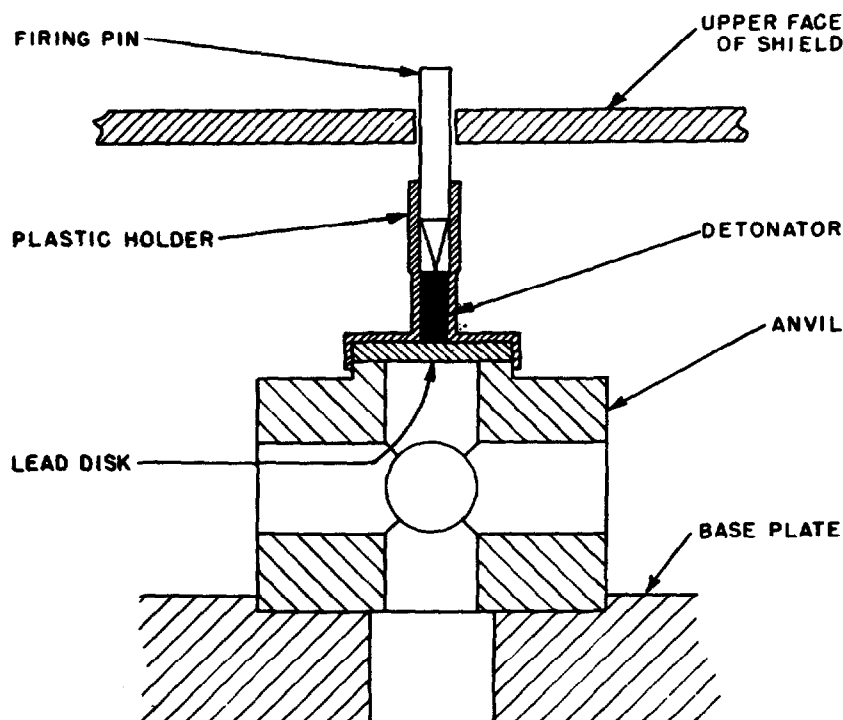

Figure 4. Detail of Lead Disk Mounting Below Detonator in Plastic Holder

Output Tests

These tests are more varied in their nature and complexity than are the input tests. This difference may be attributed to the fact that the output of a firing train component may be required to produce a wide variety of effects: to detonate a lead or booster by shock; to do mechanical work in driving a firing pin; to initiate a detonator by shock, flame, or hot particles; to ignite a delay by flame & hot particles; or to lock a train in the armed position by moving detents or expanding confining walls

Output tests for detonator type components are generally based on an attempt to measure the brisance or the peak pressure of the shock wave. The common tests for detonators are practically all applicable to each of the three main varieties, namely stab, electric and flash detonators. Following are brief descriptions of output test for detonators and primers:

a) *Output Tests for Stab Detonators.* Stab

initiated detonators may be tested for output by means of Test Set Mk136Mod0 shown in Fig 1, in which a standardized lead disc is mounted below the sample detonator, as shown in Fig 9-15, p 9-32 of Ref 14 and reproduced here as Fig 4. Detonation of the sample causes perforation of the disc with an irregular hole which has an area more or less proportional to the brisance of the detonator. The area of the hole may be measured by use of shadowgraph apparatus by some simple photocell equipment, such as described by N.L. Wadsworth in NOLM 9687(1948). Lead discs are seldom applied to electric or flash detonators unless a particular test set-up permits ready mounting of the lead disc

b) *Output Tests for Electric Detonators.*

Electrically initiated detonators may be tested by "copper block" or by "bent nail test", which are both rather qualitative. The *Nail Test* is described in Vol 1 of Encycl (Ref 30, p XIX) and more fully in the USBurMinesBull 346(1931), p 113

In the *Copper Block Test* [not to be confused with "Copper Cylinder Compression Test", described in Vol 3 of Encycl (Ref 41, p C493-L)], the detonator is fitted snugly into a drilled axial hole at the center of a copper cylinder. The outer diam of the cylinder is measured accurately before detonation and again after detonation. The detonator expln expands the cylinder by a readily measured amount, and the magnitude of this enlargement is taken as a measure of the detonator output. More accurate test is the "Sand Bomb Test", which is also used for testing the stab and flash detonators. This test designated in Ref 14 as Test Set Mk148Mod0, was briefly described in Ref 30, p XVIII under "Initiating Efficiency of Primary Explosives by Sand Test" and also on p XXI. The detailed description of Sand Bomb Tests is given in PATR 3278 (1965) (Ref 38, pp 9 to 11 and Figs 9, 10, 11 & 12). The test is considered reliable but exceedingly time consuming (Ref 14, pp 9-31 to 9-33)

c) *Output Tests for Flash Detonators.* No specific tests for flash detonators have been developed, but the following tests can be used: (1) Sand Test; (2) Hopkinson Bar Test; (3) Stauchapparat Test; (4) Gap Tests; and (5) Insensitive Explosive Tests. Of these, the NOLTR 1111 considers as most promising the Hopkinson Bar Test, which was developed in England, and is briefly described in Vol 1 of Encycl (Ref 30, p XVI). The Gap Tests are described on p XIV. The "Stauchapparaten" of Hess and Kast are described in Vol 3 of Encycl (Ref 40, pp C492 & C493) but only for determination of brisance of HE's.

A rather detailed description of Hopkinson Pressure Bar is given in Ref 14, pp 9-33 to 9-39 with Figs 9-16, 9-17, 9-18, 9-19 & 9-20

In regard to Gap Tests, it is stated in Ref 14, p 9-39, that their measurement may be considered either as an output measurement for the first (donor) explosive or as a sensitivity test for the second (acceptor) explosive, depending upon which explosive is considered to be constant in its per-

formance. When the gap test is used as an output measurement for a detonator, the completeness of detonation of the acceptor is the dependent variable to be reported. By varying the gap in small increments, it is possible to progress thru no acceptor initiation, low order initiation, and high order initiation as a function of gap length

NOLTR 1111 (Ref 14, pp 9-40 to 9-42 and Figs 9-21 & 9-22) describes a *Stauchapparat* (Crusher Gauge) which is a modification of Kast's Stauchapparat described on p C493 of Encycl, Vol 3 (Ref 41). The modified version (Fig 5, the apparatus with protective cylinder removed) consists of an anvil upon which rests 3 copper balls (of

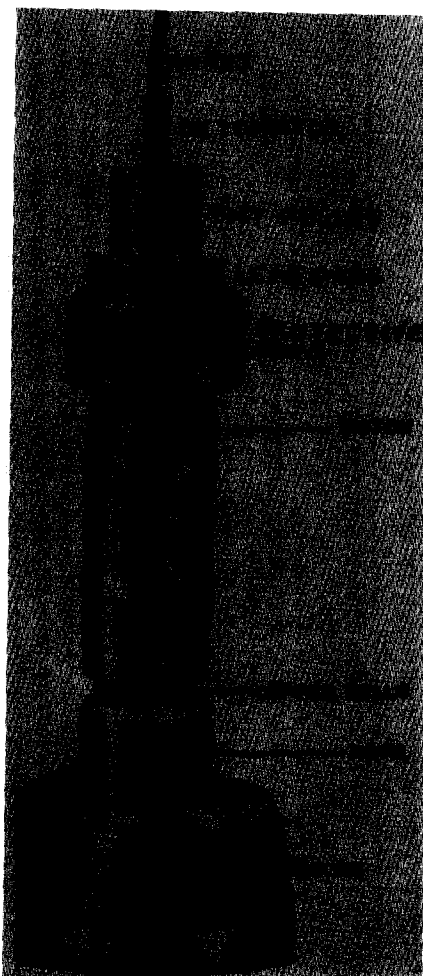

Figure 5 *Stauchapparat, Without Protective Cylinder*

known hardness and diameter); a piston which rests on top of the copper balls; a guiding cylinder surrounding the piston (not shown in Fig 5) and protective ring (cap) at the top of the piston (to resist damage to the piston by the expln of 16 g TNT pellet which is the standard acceptor explosive in this device). When TNT is exploded by a detonator, the piston is pushed down against the Cu balls squeezing them against the anvil. This action causes their deformation, diminishing the length of each of their vertical axes. The difference betw original diameter of sphere and the smaller diam of resulting ellipsoid

serves as a measure of the output of a detonator. When used in laboratory work, the apparatus must be protected by a barricade, but for field work such protection is not required. It is claimed that Stauchapparat gives results for output of detonators that check quantitatively with Hopkinson Bar. Detailed description of modified Stauchapparat is given by R. Suessle in NOLM **10665**(1950)

d) *Output Tests for Stab Primers*. Accdg to Ref 14, pp 9-42 to 9-43, such primers may use the Test Set Mk136Mod0 described here under Output Tests for Stab Detonators. However, as the brisance of stab primers

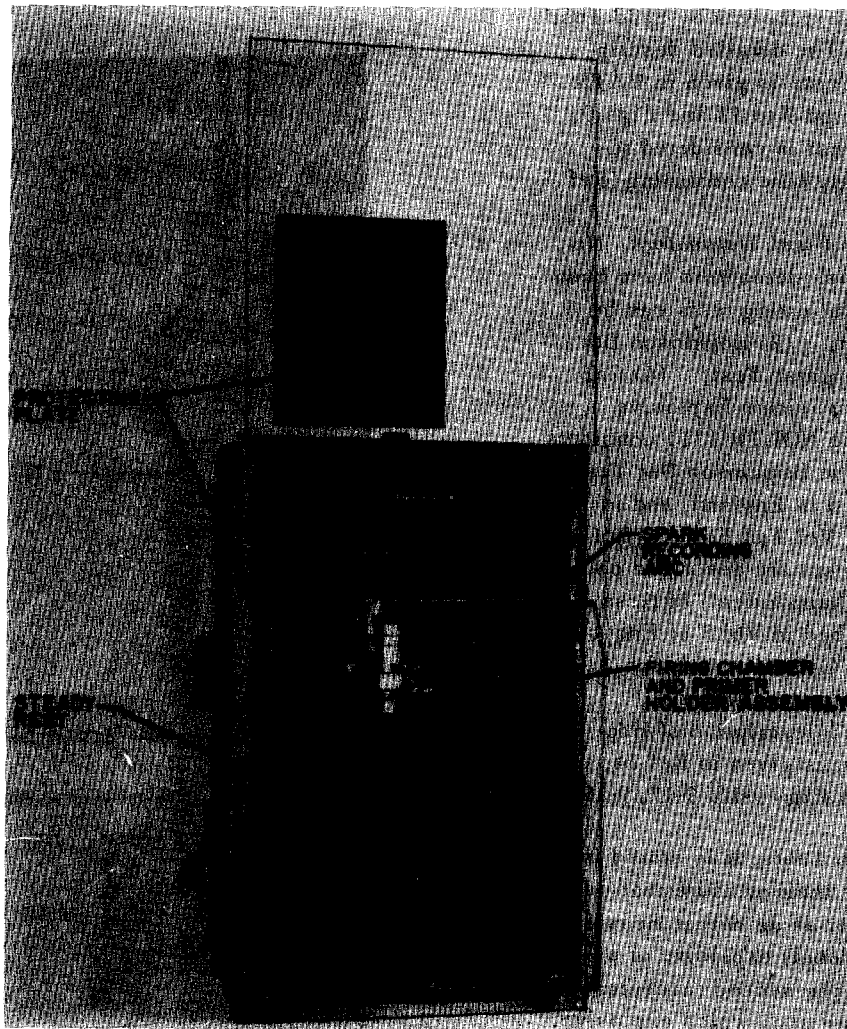

Figure 6 Test Set Mk 172 Mod 1, for Percussion, Stab, and Electric Primers

is low, one does not obtain a perforation of a lead disc, but only its indentation. The deeper the indentation, the higher is the output of a stab primer

These primers may also be tested in the "Gas Volume and Impulse Apparatus", briefly described as the "Test Set Mk175-Mod0" in Ref 14, p 9-42. Its photographic view is given as Fig 9-23 (which is not shown here). The apparatus consists of a mercury reservoir, an upright capillary tube, and a firing chamber. When a primer is fired in this test set, the hot reaction products build up pressure in the firing chamber. This pressure is communicated to the upper surface of the mercury in the reservoir, and this, in turn, causes a column of mercury to rise in the capillary tube. The mercury column rises momentarily to a considerable height in the tube and then settles down to a sustained height. By comparison with a graduated scale back of the capillary tube, both the maximum and the steady deflections of the mercury column are measured, the first being recorded as the primer "impulse" and the latter as the "cold gas volume"

A similar apparatus is described by Ohart (Ref 9, pp 49-50, Fig 15)

e) *Output Tests for Percussion Primers.* Accdg to Ref 14, pp 9-44 to 9-49, output tests for percussion initiated primers may be performed with Test Sets Mk172Mod1 (Fig 9-24), Mk173 (Fig 9-12), Mk175 (Fig 9-23) and Mk180Mod1 (Fig 9-25)

Test Set Mk172Mod1 (shown here as Fig 6), is a "torsional pendulum" deflecting in a horizontal plane against the restraint of a piano wire that is twisted by a torsional force instead of deflecting in a vertical plane against a gravity restoring force. The component to be tested is mounted in the pendulum bob and produces deflection by the reaction of the jet of rapidly moving gases which it releases. The maximum angular deflection of the torsional ballistic pendulum is a measure of the momentum of the gases and particles emitted by the sample primer. The deflec-

tion is recorded by means of a spark and waxed tape mechanism. More detailed descriptions are given by J.B. Lord in NOLM 10400 (1949) and by C.J. Zablocki et al in NOLM 10658 (1949)

Test Set Mk173Mod0 (shown in our Fig 3), incorporates a means for comparative output measurements in terms of the heat delivered to the junction of a thermocouple which is directly in the path of the hot reaction products

Test Set Mk180Mod0, known as "Primer Pressure Bomb Apparatus", conducts measurement of the pressure developed by a primer expln in a small sealed chamber. Its photographic view is given in Fig 9-25, p 9-50 of Ref 14 and a rather detailed description is given on pp 9-51 to 9-52. It was first described by H.W.L. Street in NOLM 10957 (1950)

Other methods for measuring output of percussion primers include: (1) method developed at PicArns in 1946, based on measurement of the primer light output by means of a photoelectric tube and a cathode ray oscillograph (PACChemLabRepts 114842 & 118810); (2) measurement of output in terms of the delay train firing time obtd with a pyrotechnic delay pellet; this method is described by E.F. Ward in NOL TN-310 (1950); and (3) measurement of output by comparing the intensity of sound produced by expln (Ref 14, p 9-49)

f) *Output Tests for Electric Primers.*

Accdg to Ref 14, p 9-49, the tests may be performed with Test Set Mk172Mod1 (our Fig 6); Test Set 180Mod0 (shown in Fig 9-25 of Ref 14); and Test Set Mk148Mod0, which is a Sand Bomb Test, briefly discussed under "Output Tests for Electric Detonators"

g) *Output Test Fixture (General).* This apparatus, shown in Fig 7, was developed at the McDonnell Aircraft Company, St Louis, Missouri. It is suitable for measuring the output of Detonating Cord, Detonators, Initiators, Igniters, Primers & Power Cartridges. It consists of an Energy Sensor [USP 3263489 (1966), M.L. Schimmel et al] and the Initiator Firing Block mounted on a base. The entire assembly is designated

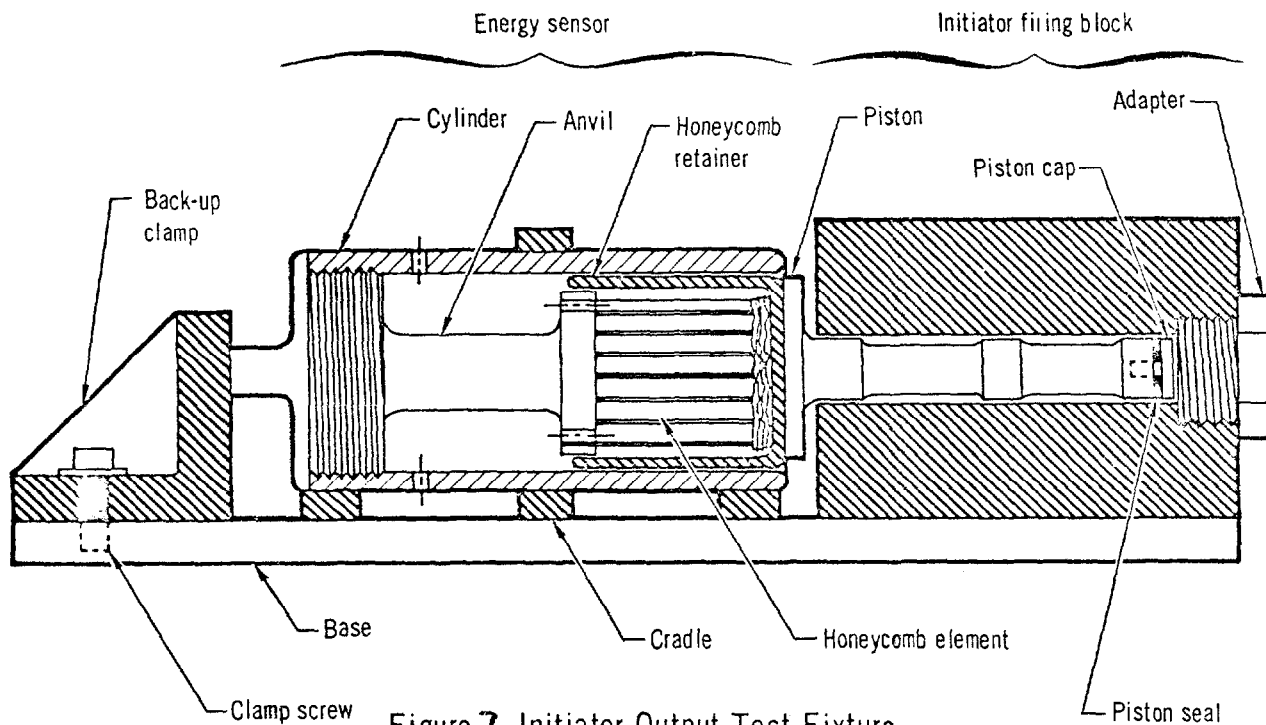

Figure 7 Initiator Output Test Fixture

as P/N 12K026-27. The detailed description of the development & use of this equipment is reported by Schimmel & Drexelius (Ref 44a)

Miscellaneous Safety Tests for Detonators and Primers

Accdg to Ref 14, p 9-52 the following tests belong in this category:

- a) *Static Detonator Safety Test.* In this test, usually performed on the assembled firing train, the slider or rotor, which interrupts the firing train when the fuze is unarmed, is varied in position by small increments and the percent of successful initiations of the detonator by the primer is plotted as a function of slider displacement. A similar plot may be made for "lead" initiation by the detonator. A more detailed description of the test is given by A.H. Erickson in NOLM 10029 (1949)
- b) *X-Ray Examination and Radium Camera Examination.* Where doubt exists as to the safety of a detonator (or primer), considerable information about the state of affairs may be obt'd by means of X-ray pictures or by "radium camera" photographs. A de-

scription of "radium camera" techniques is given in BuOrd OP 1179 (1944)

Physical Tests Required by Various US Military Specifications for Detonators, Primers, Igniters and Delays

Functioning Tests. They may be subdivided into:

- 1) *Sensitiveness (Sensitivity) Tests.* In the so-called *drop-ball test*, described in NOLR 1111 (Ref 14, pp 9-4 to 9-7), using apparatus shown in this Section, Fig 1, the detonator (or primer) is inserted in an assembly shown in Fig 4. Each detonator is resting on a lead disc either 0.065 inch or 0.134 inch thick [PA-PD-124 (1953), p 3], while each primer is resting on an aluminum disc of thicknesses 0.012, 0.032 or 0.040 inches [MIL-P-14100 (Ord) (1955), 3]. Over each component is placed a firing pin and a standard steel ball (usually 1-3/16 inch in diameter and weighing 3.95 ounces), held by an electromagnet, is dropped from the heights prescribed by specifications. The height shall be measured from the top of firing pin to the bottom of the ball. Each item shall function on the first attempt and

shall cause a perforation of the disc of prescribed material and thickness to not less than the minimum diameter indicated in special tables. Minimum diameters of perforations by detonators in lead discs, when 3.95-oz balls are dropped from the heights 3 to 12 inches, range between 1/16 and 1/4 inches; while minimum diameters of perforations by primers in aluminum discs, when 3.95-oz balls are dropped from the heights 1.5 to 3 inches, range between 1/4 and 5/16 inches. Tests are sometimes made with balls weighing as little as 1.94 oz and as high as 15.55 oz

A modification of this test is described in specification MIL-P-13392A (MU) Amendment 1 (1965), p 14

In the *drop-test* described by Ohart (Ref 9, p 48 & Fig 14 on p 49), the sensitivity of primers (and detonators) was judged by the height of the drop of a ball and for many years it has been required that sample detonators and primers from a given lot fire at a certain height and fail to fire at a certain lesser height, this last requirement supposedly insuring against accidental firing in handling and transportation. Detn of this value is known as the *non-functioning test*

Ohart also stated that it has been shown that the drop-test method, in which only the height of drop is a decisive factor, does not give a true measure of the quality of the lot, and the so-called *run-down test* method is coming into favor. In this method a given number of primers (or detonators) are fired at heights between the all-fire and all-misfire heights, the percentage of firing at each height being recorded. The average height and standard deviations are computed to determine the satisfactoriness of the lot by comparing with standards established from a consideration of the quality level it is desired to maintain

A ball-drop test for LA & other primary expl is described in Vol. 1 of Encycl (Ref 30, p A573-L)

2) *Waterproofness*. The detonator and primer assemblies shall be waterproof, as evidenced by normal functioning after water

immersion when tested as specified below. Samples representing each lot are immersed in water of the same temperature to a depth of not less than 2 inches and allowed to stand for at least 48 hrs. Within one hour after removal from the water the detonators (or primers) shall be testing according to the sensitivity test described above

3) *Workmanship*. All parts shall be free of chips, dirt, grease, rust and other foreign material. The cleaning method used shall not be injurious to any of the parts nor shall the parts be contaminated by the cleaning agents used

4) *Check Test for Possible Deterioration*. If the total elapsed time between original acceptance of any detonator (or primer) lot and assembly of that lot into the ammunition component with which it is issued exceeds two months or if the detonators (or primers) have been subjected to adverse conditions at any time since previous tests, the lot shall be subjected to, and must satisfactorily pass, the check test for sensitivity and waterproofness as described above. Should any lot fail the retests, it shall be rejected

Besides the above standard tests for detonators and primers which are included in all specifications for these items, there are tests which are not included in every specification. These tests are:

- a) *Sand Test* for detonator assemblies M17, M21, M30 & M35 as described in Spec MIL-D-002493, Interim Amendment 1 (MU) (1964), pp 8-9 and Figs 2 & 3
- b) *Duds Test* (if required). Each primer of the sample of 300 primers is tested by dropping a steel ball weighing 1.94 ± 0.02 ounces on the firing pin of the apparatus described here under "Sensitiveness Tests", from a height not to exceed 15 inches. The primers shall not fail to function on first attempt and no primer shall show evidence of a hangfire or squibbing, and the cup shall rupture sufficiently to expose the primer anvil [Spec MIL-P-12951D (MU) (1965), pp 2 & 11]. In Spec MIL-P-13392A (MU) Amend 1 (1965), p 15, the height of drop is specified as 8 inches

c) *Output.* The primer assembly shall initiate the 0.050-second Delay Element described in MIL-D-46486C (1967), pp 3 & 15, and the cup shall rupture sufficiently to expose the primer anvil when tested as described below. The primer is assembled with the 0.05-sec M2 Delay Element (previously tested by detonating M54 Percussion Primer by means of a steel firing pin having a point of 28° which has a 0.015 to 0.004-inch flat and a 0.004-inch max radius). A steel ball weighing 7.94 ± 0.02 ounces is dropped from a height of 10 inches on to the firing pin [MIL-P-13392A (MU), Amendment 1 (1965)]. In Spec MIL-14137A (MU), Amendment 1 (1965), pp 2-3, the requirement is that the primer shall function on the first attempt and shall cause a perforation of 1/8-inch diameter minimum in lead sheet, 0.1345-inch when tested as described here under "Sensitivity Tests"

In the book of Ohart (Ref 9, pp 49-50) are described two other tests for primers (and detonators): impulse and gas volume

a) *Impulse.* When a primer is fired, the force of detonation or length of spit, known as "impulse", is measured by the maximum displacement of a mercury column resulting from firing in an apparatus shown in Fig 15, p 50 [Compare with the "Gas Volume and Impulse Apparatus" Mk175Mod0 shown in Fig 9-23, p 9-43 of Ref 14 and with Fig 5, shown on p10 of PATR 2299 (1956) (Ref 21)] There is a linear relationship between the length of the spit and wt of the charge. If a primer is intended to initiate a delay column, the impulse should be controlled, because too low impulse might result in non-ignition, while too high impulse might blow away part of the column at ignition and change the delay time. Igniting the delay column the same way every time with the same primer impulse leads to uniformity of burning time

b) *Gas Volume.* Gas volume of a primer (or detonator) is of interest because it is also a measure of charge wt and is related to impulse. The ratio between gas volume and impulse can serve as a check on the actual charge composition, because if this

ratio changes it means that the compn may have changed, whereas if the ratio stays about constant, the variable is the charge wt and not the compn. Furthermore, gas vol is important when primers are used in obturated elements because the proper value, as well as uniformity of gas volume, is conducive towards uniformity of functioning of the obturated element, usually a delay column. Gas volume evolved on functioning of a primer (or detonator) can be determined by the same apparatus as used for impulse. The mercury column momentarily displaced at the determination of impulse, is allowed to come to rest and the level of column is measured in mls

Specification MIL-C-12927B (MU) Amendment 1, (1964) for *Ignition Cartridge M2E1*, requires in addn to functioning, non-functioning, waterproofness and workmanship tests, the *proving ground test*. In this test, performed at Government Proving Ground, the loaded cartridges are assembled to mortar rounds for which the cartridges are designed and sand-loaded to a total individual wt of ca 26.00 lb (w/o extension). After elevating the mortar tubes to an angle of 45°, the rounds are fired and results observed. In lieu of sand-loaded rounds, proof projectiles of acceptable types may be used. Observations shall be made for compliance with the applicable requirements

Specification requirements for *electric detonators and primers* usually include:

a) *Non-functioning.* Shall not function by a current of certain strength. For example, Electric Primer Igniter M74, described in MIL-I-46521B (MU) (1966), shall not function when applying (behind a barricade) an electrical current of 190 to 200 milliamperes, using the electrode as one contact point and the igniter body as the other. The time of the current flow shall be 1 second minimum

b) *Functioning.* Shall function by a current of certain strength. For example, Electric Primer Igniter M74 shall function when tested by applying an electric current of 1.25 amperes, max, using the electrode for one contact point and the igniter body as the other. The time of the current flow shall

be 1/10th sec, max

c) *Electrical Resistance*. Shall have an electrical resistance within certain limits, such as between 0.80 and 1.80 ohms for Electric Primer Igniter M74. The test is conducted by applying an electric current of 20 milliamperes, max, using the electrode as one contact point and the igniter body as the other

d) *Workmanship*. All parts and assemblies shall be free of burrs, sharp edges, cracks, dirt, grease, rust and other foreign matter. The cleaning method used shall not be injurious to any part nor shall the parts be contaminated by the cleaning agent. Exterior surface coatings shall be continuous except for a few light scratches not exposing the base material. All markings shall be readable and all packing components shall be dry

For *Combination (Percussion, Electric) Primer M75*, the requirements of Spec MIL-P-46279 (Ord) (1960) include the following tests:

- a) Non-functioning, Percussion phase
- b) Non-functioning, Electrical phase
- c) Functioning, Percussion phase
- d) Functioning, Electrical phase
- e) Firing (Proving ground). Percussion phase
- f) Firing (Proving ground). Electrical phase
- g) Workmanship

For *Delay Elements T6E4 and T5E3*, the requirements of Spec MIL-D-46483B (MU) (1964) and Engineering Orders EO-PA-52713-2 (May 1968) and EO-PA-53139-2 (July 1968) include the following tests:

a) *Static Functioning*. The sample units shall be temperature conditioned at the specified temp (such as 160° F or -65° F) for a min of 6 hrs. To maintain the temp until tested, the units shall be conditioned in an insulated container (such as of low density plastic foam) with cover removed during conditioning. Before removal from the chamber, the container shall be covered and remain so until the delay element is to be assembled into the test equipment. The test is performed immediately by dropping a 4-ounce ball on the firing pin from a height of 10 inches (See under "Sensitiveness

Tests"). Delay times shall be recorded to the nearest 0.01 sec. Delay times for T5E3 are betw 11 & 17 secs, while for T6E4 they are 4 to 8 secs. Any unit which exhibits flame at any point other than vent hole shall be classed as defective

b) *Impact Functioning*. Delay element assemblies, following temp conditioning at 160° F and -65° F, as described above, shall not fail to function and shall comply with delay requirements specified above, when subjected to a drop of specified wt
Note: The wt is not specified but in identical test for Delay Element M9, described in MIL-D-46206D (MU) (1966), p 3, it is stated that the wt is 7000 g

c) *X-Ray Examination*. The unit shall be X-rayed normal to its widest axis. The assembly shall show no evidence that the M7 relay assembly is missing, cocked or incorrectly positioned; also that not more than one relay has been assembled, that any delay or igniter chge is missing or mislocated or that any primer is inverted or incorrectly positioned and any other evidence of poor workmanship or damage which might occur during loading operation

For *Blasting Fuse Igniter, Friction Type, M3A1*, covered by Spec PA-PD-2111D (1966), there are the following tests:

- a) *Workmanship*. Same as for other items used for initiation
- b) *Functioning*. A piece of safety fuse, 3/16 by 3 inches shall be inserted not less than 3/4 of inch into the igniter to test until firmly held in place by the ferrule prongs. The ensemble is placed in a test fixture (Inspection Equipment Tabulation No ET-8833721) and the friction wire of igniter quickly withdrawn. Any igniter which fails to ignite the safety fuse shall be classed as defective. The test is performed at a Government Proving Ground
- c) *Tumbling*. This test shall be conducted 100% for all igniter-blasting fuse assemblies, (made as described above), prior to assembly of ferrule. Tumbling shall be conducted for a minimum of 20 mins. Any assembly ignited during tumbling shall be discarded. Tumbling is conducted in an apparatus made

of 3/4-inch plywood with dimensions 37½ x 37½ inches and 24 inches deep with 4 baffles centered in and perpendicular to the 4 walls. Baffles are 9 inches wide by 18 inches deep. The tumbler shall rotate at 9±1 RPM and be canted 72.5° from the horizontal (See PA Dwg 8833721 (Oct 1959)

d) *Salt Spray Test*, mentioned on pp 12 & 15, shall be performed in accordance with Specs QQ-Z-325 or QQ-P-416 whichever is applicable. The duration of test is 48 hrs. This test is similar to that described in MIL-STD-331 as Test No 107. It is briefly described here under Physical Testing of Fuzes, item q

Physical Testing of Fuzes

A complete description of fuze testing is given in Refs 39 & 43. Some tests are described in Refs 9 & 11 and also in Ref 33

Following is a brief description of tests, arranged in alphabetical order:

a) *Accidental Release (Low Altitude, Hard Surface)*. This field test is used to determine whether or not fuzes, assembled to missiles released from an aircraft during take-off or landing, will remain safe after hard surface (such as paved runway) impact. The test consists of dropping fully-loaded fuzes with inert boosters, assembled to inert loaded missiles, with which they are intended to be used, from a low-flying aircraft onto a hard surface. The fuzes are released "safe" or prevented from arming by the safety feature that is used while they are being carried out by the aircraft. A fuze is judged to have passed the test if it has not reacted in such a way as would lead to the explosion of live missile and remains in a safe condition for removal and disposition. A complete description is given as Test No 206 in MIL-STD-331 (1966) & change 2 (1967)

b) *Air Delivery, Simulated (Parachute Drop)*. This field test is designed to check safety and operability of the fuze following low velocity and malfunctioning air delivery drops by parachute. Its "low-velocity simulation test" consists of subjecting fuzes (fully-loaded but unarmed) to free drops from 14 feet to obtain a terminal

velocity (See Note below) of 30 fps. Its "malfunctioning drop simulation test" consists of dropping fuzes from 350 ft to achieve terminal velocity of 150 fps. All fuzes shall be dropped on a compact soil. After low velocity drop the fuze shall be operable and safe to handle and use, while after malfunctioning test, the fuze shall be safe to handle, but need not be operable. A complete description is given as Test No T213 in MIL-STD-331

Note: Terminal velocity is the constant velocity of a falling body attained when the air resistance has become equal to the force of gravity acting upon the body

c) *Catapult and Arrested Landing*. The purpose of this field test is to determine the safety and operability of the fuze after subjection to the acceleration forces of catapult takeoff and to the deceleration forces of arrested landing. In this test, a fully-loaded, but unarmed, fuze with inert booster is assembled to an inert munition for which it was designed, and the ensemble catapulted or accelerated to obtain the acceleration time patterns required. Each fuze is examined after testing and it is required that it remain operable as well as safe for handling, storage, and subsequent service use (Test No 212 of MIL-STD-331)

d₁) *Detonator Output Measurement by the Lead Disc Test*. This test serves to measure output and to check uniformity of the performance of detonators. The test consists of initiating a detonator by dropping a steel ball from a predetermined height on top of a firing pin, followed by measuring the perforation of a lead disc which is in contact with the detonator on firing. A complete description of procedure is given as Test No 302 in MIL-STD-331. Photographic view of drop-ball apparatus is shown in Fig 1 given at the beginning of this Section 9 (See also Figs 2, 3 & 4)

d₂) *Explosive Component Output Measurement by the Aluminum Dent Test*. This test is designed to measure output and to check uniformity of the performance of the com-

ponent as designed, taking into consideration the confinement of the component in the eventual application. The test consists of initiating confined explosive components in contact with aluminum blocks and measuring the depths of indentation (dents) in the blocks resulting from the explosions. The depth of the dent is a measure of the output. The test applies only to components producing dents greater than 0.005 and smaller than 0.100 inch in depth. A drop-ball apparatus similar to the one employed in lead-disc test, is used here. A new block is used for each test. A complete description of the procedure is given as Test No 303 in MIL-STD-331

d₃) *Explosive Component Output Measurement by Steel Dent.* The test is similar to the Al dent test. It applies only to components producing dents greater than 0.005 and smaller than 0.100 inch in depth. A complete description of the procedure is given as Test No 301.1 in MIL-STD-331

e) *Extreme Temperature Storage.* The purpose of this test is to check the ability of fuzes to withstand prolonged storage at extreme temperatures. The test consists of placing bare, but completely assembled fuzes (including all explosive elements which are part of the fuze design), in a constant temperature chamber at minus 65°F for 28 days, followed by exposure in a similar chamber at plus 160°F for an additional 28 days. These tests shall not alter any of the properties of the fuze. A complete description of the procedure is given as Test No 112 of MIL-STD-331

f₁) *Field Parachute Drop.* This test is designed to determine whether a fuze will be safe and operable after subjection to the forces incident to parachute delivery. The test consists of dropping onto "normal soil" (See Note below) from an aircraft, in packages to which parachutes are attached. The fuzes (fully-loaded but unarmed) are assembled before dropping to inert warheads, inert complete rounds, or as separate components, depending upon how they may be delivered to the user in the field. Drops are made with parachute open, and also

with parachutes tied to prevent opening. In drops in which the parachute opens, as intended, the fuze shall be safe to handle and remain operable. For drops in which the parachute does not open, the fuze shall not function, shall be safe to handle, but need not be operable. A complete description of the procedure is given as Test No 211 in MIL-STD-331

Note: "Normal soil" is considered to be a soil of any kind that is not marshy, does not contain a large proportion of rock, has not been artificially packed or hardened and is suitable for cultivation. If the soil is in a desert area, it could be cultivated if properly irrigated

f₂) *Five-Foot Drop.* The purpose of this field test is to check the safety and operability of the fuze after mishandling. The test consists of dropping fuzes five feet onto a steel plate which is solidly supported by concrete. The drop equipment provides an unimpeded free fall prior to striking the plate and permits rebounding. The orientation of the assemblies on striking are: (1) nose down; (2) base down; (3) horizontal; (4) axis 45° from vertical, nose down; and (5) axis 45° from vertical, base down. The fuzes must be safe and operable following this test. A complete description of procedure is given as Test No 111 in MIL-STD-331

f₃) *Forty-Foot Drop.* The purpose of this field test is to check the safety and ruggedness of the fuze. The test consists of a series of 5 drops, each employing a fully-loaded, "unarmed" fuze assembled to an appropriate inert-loaded bomb, projectile or warhead, with each drop having a different orientation of impact. The test assembly is dropped 40 feet in free fall onto a steel plate solidly supported on a reinforced concrete base. The impact area shall be surrounded on all four sides by an enclosure of sufficient height and strength to contain the components during rebound. The fuze shall remain, after testing, safe to handle, but does not need to be operable. A complete description of the procedure is given as Test No 103 in MIL-STD-331

g) *Fungus Resistance*. The purpose of this laboratory test is to determine if the fuze performance is adversely affected by a fungus environment. The test consists of exposing bare, fully-loaded, but unarmed fuzes, inoculated with fungi, to conditions of temperature and humidity conducive to the growth of fungi. The test is conducted in a chamber or cabinet with auxiliary instrumentation for maintaining constant temp and humidity. Provisions must be made to prevent condensation from dripping on the fuzes. The fuze must be safe and operable following this test. A complete description of the procedure is given as Test No 110 in MIL-STD-331

h) *Impact Safe Distance (Projectile)*. This field test is intended to determine the minimum distance along the trajectory at which the fuze will function on impact. An inert projectile equipped with a fully-loaded, but unarmed, fuze is propelled against a target. The target is placed at several positions about the estimated 50% functioning distance and the percentage of functioning is determined at each position. A complete description of the procedure is given as Test No 208 in MIL-STD-331

i₁) *Jettison (Aircraft Safe Drop) Fuze*. This field test is designed to det whether or not the fuze will undergo severe earth and water impacts in unarmed position without initiating an expl. In this test a fully-loaded fuze, locked in the "safe" position, is assembled in an appropriate explosive-loaded bomb or missile warhead, and "jettisoned" from an airplane in-flight onto water or "normal soil" (See Note, under item f₁). The fuze passes the test if it does not initiate on expln. A complete description of the procedure is given as Test No 201.1 in MIL-STD-331

i₂) *Jettison (Aircraft Safe Drop) (Fuze System)*. This field test is designed to det whether a fuzed munition can be intentionally dropped so as not to arm, and can withstand earth and water impact and water immersion without initiating the main charge. In this test, a fully-loaded, but unarmed fuze, is assembled to the loaded bomb or missile

warhead together with all other components of the fuzing system that are normally used in the munition, and dropped from an airplane in flight onto water or normal soil (See Note under item f₁). Observations are made of the manner in which the munition leaves the aircraft and of the impact to det whether or not arming system prevented an expln from taking place. A fuzing system is judged to have passed the test if there is no expln of the main chge. A complete description of the procedure is given as Test No 205 in MIL-STD-331

i₃) *Jettison (Aircraft Safe Firing, Rocket Type)*. This field test is designed to det whether or not a rocket-type fuze will undergo severe earth impacts in the unarmed condition without initiating the associated payload. In this test a fully-loaded fuze system is assembled in a rocket warhead, and jettisoned from an airplane in flight onto water or "normal soil" (See Note under item f₁). A fuze is judged to pass the test if no expln of rocket payload takes place. A complete description of the procedure is given as Test No 204 in MIL-STD-331

j₁) *Jettison (Simulated Aircraft Safe Drop from Ground Launcher)*. The purpose of this field test is to det whether or not the fuze will undergo severe earth impacts in the unarmed condition without initiating the associated payload. The test consists of propelling, from a horizontal ground launcher, fully-loaded but unarmed fuzes assembled in appropriate explosive-loaded bombs, or missiles against vertical sand-filled bins. The missiles are accelerated to a velocity of approximately that obtd by dropping the item in level flight from an altitude of 15000 ft. The fuze is judged to have passed this test if expln of the missile is not caused by the fuze. A complete description of the procedure is given as Test No 203 in MIL-STD-331

j₂) *Jettison (Simulated Aircraft Safe Firing, from Ground Launcher) (Rocket Type)*. This field test is intended to det whether or not the fuze will undergo severe earth impacts in the unarmed condition without initiating associated expls. The test consists of launching a rocket-type explosive-loaded

missile, provided with a fully-loaded fuze in the "safe" position, against a sand-filled bin. The missile is accelerated to a velocity simulating that of launching the missile from an altitude that would allow it to attain terminal velocity (See Note under item b). A fuze is judged to have passed the test if it does not initiate an expln. A complete description of the procedure is given as Test 202.1 in MIL-STD-331

k) *Jolt Test*. This laboratory test is designed to check the safety and ruggedness of the fuze design. Accdg to Ohart (Ref 9, p 135), jolt and jumble tests serve to ascertain whether the fuzes and boosters are so designed that: (1) no parts or subassemblies become loose; (2) that staked, crimped and threaded parts have been assembled properly; (3) that expl elements like primers and detonators do not become loose or spill their charges; (4) that shear pins do not shear; and (5) that safety pins are adequate. The jolt test consists of assembling a fully-loaded, but unarmed, fuze into the end of a pivoted arm which under cam action falls by gravity thru 4 inch on a leather-padded anvil, giving a considerable jar to the item. It is usually tested for 1750 jolts of fuze arm at the standard speed of 35 blows per minute, in each of the 3 positions, vertically up, down and horizontal. Photographic view is given in Fig 54, p 136 of Ref 9

Accdg to MIL-STD-331 (Ref 43) where this test is described in detail as Test No 101, in that part of the test where the fuzes are positioned with the longitudinal axis in a horizontal direction, the fuzes are oriented so as to expose what is considered to be the most vulnerable plane of weakness

In general, it is not required that the fuzes be operable after this test, but the samples judged to have withstood this test are those in which: (1) no elements shall explode and (2) no parts shall be broken, be deformed, be displaced, come apart, or arm in such a manner as to make the assembly unsafe to handle or dangerous to use. An assembly drawing of the jolt machine is shown in Fig 1 of Ref 43 and a photo-

graphic view in Fig 2

l) *Jumble Test*. This laboratory test serves the same purpose as the "jolt test", described here as item k. The jumble machine consists of a wood-lined steel box which is rotated about two diagonal corners of the bottom at the standard speed of 30 rpm. A bare, fully-loaded, but unarmed fuze is placed inside the box and after covering the box, it is rotated for a total of 3600 revolutions. This action makes the fuze roll inside the box, receiving bumps at random. A complete description of the procedure is given as Test No 102 in MIL-STD-331, where also a drawing of machine and its photographic view are given. Ohart (Ref 9, pp 135-36) also gives a brief description of the test and a photographic view of the machine (Fig 55)

m) *Missile Pull-Off from Aircraft on Arrested Landing (Ground Launcher Simulated)*. This field test serves to assure that the fully-loaded fuze will undergo impacts in the unarmed condition equivalent to those that might be received if the missile were to be subjected to impact on a deck and/or bulkhead after breaking loose from an aircraft subjected to an arrested landing. An inert-loaded missile with an inert-loaded booster, assembled with fully-loaded but unarmed fuze is propelled from a ground launcher oriented to give an angle of impact such as that obtd with a missile breaking loose from a landing aircraft. The missile shall be accelerated to a velocity of ca 150 fps by a suitable means, such as a rocket motor, before striking the target. The motor shall be burned out before striking the target, in order to assure that there shall be no confusion between fuze detonation and motor deflagration. After leaving the launcher, the missile impacts a horizontal steel deck simulating the flight deck of an aircraft carrier and 5 ft below the axis of the rocket when on the launcher. Forty to sixty ft beyond the initial point of impact on the steel plate there is a vertical steel bulkhead normal to the line of flight. It shall be of a thickness sufficient to deflect the missile. A fuze is judged to have passed

the test if it has not reacted in such a way as would lead to the expln of live missile or cause a condition rendering the missile unsafe for removal and disposition. A complete description of the procedure is given as Test No 209 in MIL-STD-331

n) *Muzzle Impact Safety (Projectile)*. This field test is designed to det if the safety devices of a fuze are so arranged that they will prevent detonation of the fuze-projectile combination on any impact close to the muzzle of the gun. This usually implies similar safety while in the bore of the gun. In this test an inert-loaded projectile provided (sometimes) with a spotting charge and a fully-loaded, but unarmed fuze, is fired against a wooden or metallic panel placed as close as possible to the muzzle. If a fuze is in a functioning condition when it leaves the bore of gun, no explosive elements beyond the last safety device of the fuze shall function before or as a result of impact with the target. A complete description of the procedure is given as Test No 207 in MIL-STD-331

o) *Rain Test (Exposed Fuze Storage)*. The purpose of this laboratory test is to det the ability of a fuze to remain safe and operable after being subjected to water spray and/or rainfall. For this test bare, fully-loaded fuzes, are placed in a test chamber, where they are subjected to a water spray from a shower head, maintained at ca 70° F. Duration of test is 2 hours for each of the 3 positions of fuze: upright, horizontal, and inverted. After completion of the test, the fuzes shall be safe and operable and no components or materials shall be deformed, changed, or otherwise altered. A complete description of the procedure is given as Test No 109 in MIL-STD-331

p) *Rough Handling Test (Packaged)*. The purpose of this test is to det the safety and operability of fuzes after rough handling in the standard packaged condition. The test consists of subjecting the packaged, fully-loaded but unarmed, fuzes to the following procedures:

(1) *Vibration*. The package with fuzes, securely fastened to the table of a "vibrator"

(such as shown in Fig 225 of Ref 9, p 360) is subjected to vibrations for a given period of time, such as 4 hrs as given in Ref 9, p 380, where also is given the frequency of vibration as 550 cycles per minute. Such a test corresponds in a rough way to vibration in the hold of a ship, in a plane or in a railroad car. A more complete description of the procedure is given as Test No 114 in MIL-STD-331

(2) *Free Fall Drop*. The packages with fuzes shall be dropped free fall 36 inches onto a rigid horizontal surface 6 times, 1 drop on each of 4 diagonally opposed corners, plus one flat drop on bottom and one flat drop on one end. If the container is of the drum type, the top and bottom are quartered and the above test is applied to each of the quartered sections. Photographic view of "drop apparatus" is given in Fig 225, p 381 of Ref 9

(3) *Recurring Impact*. The test consists of subjecting packaged fuzes to repeated impacts for 30 minutes. The package shall be rigidly attached to the wooden mounting platform which has essentially circular motion in the vertical plane of one-inch double amplitude. The frequency of vibrations shall be varied until the package separates from the platform by 3/16 inch, measured on any edge at or near the top of the stroke of the platform

It is required that the fuzes shall be safe and operable after these tests, provided that the package has not spilled its contents. If the package breaks open, or spills its contents, the test is invalid

More detailed description of procedures are given as Test No 114 in MIL-STD-331

q) *Salt Spray (Fog) Test*. The purpose of this laboratory test is to ascertain the ability of fuzes to resist the effects of a moist, salt-laden atmosphere.

The test consists of exposing bare, fully-loaded fuzes to a salt spray (fog) atmosphere of a special chamber, continuously, for 48 hrs to check operability, and 96 hrs to check safety. The equipment of chamber includes an internal salt soln (20 parts of NaCl in 80 ps of w) reservoir, two or more atomizing

or spray nozzles, test specimen supports, a chamber heating and temperature control system, a source of compressed air, a pressure regulator and a compressed air humidifying system. The salt spray (fog) is produced by blowing humidified air thru an atomizer or nozzle to produce a stream of fine particles. The nozzle shall be so located (or baffled) as to prevent direct impingement on the test specimen. The air in the chamber shall contain sufficient water vapor to be equilibrium with the chamber atm which shall have RH of 84 to 90% at a temp betw 92 and 97° F. A more complete description of the procedure is given as Test No 107 in MIL-STD-331, where two figs are included: (1) Salt spray (fog) chamber and (2) Schematic layout of salt spray (fog) chamber

r) *Sand and Dust Test.* The purpose of this test is to check the ability of fuzes to withstand exposure to a sand and dust environment. The test consists of exposing bare fully-loaded fuzes to a turbulent sand and dust atmosphere at specified temperatures and humidity for a period of 14 hrs. The equipment required for this test consists of a chamber and accessories to control sand and dust concns, velocity, temp and humidity. The fuzes shall be safe and operable following this test. A complete description of the procedure is given as Test No 116 in MIL-STD-331

s) *Static Detonator Safety.* The purpose of this test is to check the safety of the fuze design when the detonators and/or other elements contg an expl more sensitive than standard "lead" charge expl are fired in an unarmed but fully-loaded fuze. The test consists of firing one or more-expl components in sample fuzes, checking the effectiveness of the expl train interrupter, and detg whether or not there is ejection of parts or deformation or shattering which might result in unsafe conditions. There are several ways to conduct these tests. They are described in detail as Test No 115 in MIL-STD-331. All fuze expl elements shall be present in the fuze during the tests.

The criteria by which the samples are judged to have withstood this test are as follows: There shall be no detonation, burning, charring, scorching, or melting of the expl "lead" or booster chge of the fuze, or expls in the associated service item. Smudging of the surfaces of the expls mentioned, due to deposits resulting from the firing of the sensitive elements is permitted, provided the fuze remains safe during handling, transportation or use

Typical examples of the methods may be found in the following report: H.P. Culling, "Statistical Methods Appropriate for Evaluation Tests of Fuze Explosive-Train Safety and Reliability", NAVORD Rept No 2101 (1953)

t) *Temperature and Humidity.* The purpose of this laboratory test is to check the ability of fuzes to withstand adverse climatic conditions of temperature and humidity. The test consists of exposing bare, fully-loaded fuzes to the schedule of temperatures and humidities for a total of 28 days. The test is made up of two complete 14-day "JAN Temperature and Humidity Cycles". Each of these cycles consists of cycling fuzes 9 times between the extremes of plus 160° F (95% RH) and minus 65° F with additional storage at plus 160° F (95% RH) and minus 80° F. The special equipment to run this test consists of commercially available chambers or cabinets contg features to control temp and humidity. The fuzes must be safe and operable following this test. A complete description of the procedure is given as Test No 105 in MIL-STD-331 and also in PATR 1800 (Oct 1950), "Temperature and Humidity Test", by J.H. McIver

u) *Thermal Shock.* The purpose of this laboratory test is to det whether the fuzes will withstand the effects of sudden changes. The test consists of placing fully-loaded fuzes in a chamber (precondition at minus 65° F) for a minimum of 4 hrs, removing them and placing them within 20 secs in a chamber at plus 160° and less than 20% RH for a minimum of 4 hrs. Then the fuzes are placed in the chamber at minus 65°, and this cycle of high and low temps is repeated 3 times.

The fuzes must be safe and operable following this test and no components or materials shall become deformed or altered. A complete description of the test is given as Test No 113 in MIL-STD-331

v) *Time-to-Air Burst (Projectile Time)*. The purpose of this test is to det the timing error of the fuze under field firing conditions.

The test consists of firing an expl-loaded projectile provided with a fully-loaded time fuze, set to function at a predetermined time. The time to burst of the fuze is detd by measuring the time of flight of the projectile from the weapon to the point of burst. The time to burst is measured by one of the following "fuze chronographs":

1) Aberdeen Chronograph, such as described in Vol 3 of Encycl under CHRONOGRAPHS (Ref 41, p C308-R)

2) Jefferson Chronograph, described as Test 110 of MIL-STD-331, p 5

3) Eastman Kodak Fuze Chronograph (Infrared Burst Time Indicator) described as Test 110 of MIL-STD-331, p 5

The time may also be checked by stop watches, or electric clocks

A complete description of the procedures is given as Test No 110 in MIL-STD-331, where the following figs are included:

Fig 1, Photoelectric Cell Impulse Tube in Aberdeen Fuze Chronograph; Fig 2, Recorder-Aberdeen Fuze Chronograph; Fig 3, Mirror Mound - Jefferson Fuze Chronograph; Fig 4, Tripod Assembly - Burst Time Indicator; and Fig 5, Control and Indicator Assembly - Burst Time Indicator

w) *Transportation Vibration*. The purpose of this test is to check the safety and reliability of the fuze design under a wide variety of transportation conditions. The test consists of vibrating bare, fully-loaded fuzes according to a specified schedule of frequencies, amplitudes and durations while being maintained at prescribed temp conditions. The vibration equipment required to conduct this test may be any remotely controlled vibration machine, such as "mechanical direct-drive", "mechanical reaction", or "electrodynamic" type, producing essentially rectilinear simple harmonic

motion and having the necessary capacity for force output, weight of load, and frequency range. There are two procedures for conducting this test. They are described in detail as Test No 104 in MIL-STD-331.

Procedure I is applicable to fuzes during their development, while Procedure II is applicable to fuzes during production. The fuzes must be safe and operable following these tests

x) *Vacuum-Steam Pressure*. The purpose of this test is to check the ability of fuzes to withstand tropical climates. The test consists of subjecting each fully-loaded fuze to 1000 fifteen-minute consecutive cycles in a vacuum-steam-pressure chamber, as described in detail in Test No 106, MIL-STD-331. This test of 1000 cycles takes ca 10 days of continuous running time. The fuze must be safe and operable following this test. Variations of temp are from 126° F to 154° F, with pressure variations from 28 inches of mercury below atmospheric to a pressure of 25 psi (gauge)

y) *Waterproofness*. The purpose of this test is to check the ability of a fuze to withstand submersion in shallow water. The test consists of subjecting bare, fully-loaded fuzes to immersion for one hour in an aqueous sodium fluoresceinate (uranin) under a pressure of ca 15 psi (gauge) at 70° F, and subsequently examining the disassembled fuzes for evidence of water entry. The equipment for this test includes a pressure vessel capable of withstanding safely the applied pressure. The fuzes must be safe and operable following this test. A complete description of the procedure is described as Test No 108 in MIL-STD-331

The tests for fuzes briefly described above are described more fully in MIL-STD-331 (Ref 43) and also in Vol VII of Odierno's, "Information Pertaining to Fuzes" (Ref 39). Odierno also describes the following tests which are not included in Ref 43

A1) *Air Gun Test*. The purpose of this test is to obtain information regarding the effect of linear acceleration on a fuze or any of its components. The fuze, assembled

in a piston, is propelled by compressed air and is stopped by compressed air ahead of the piston. At times the air gun has been used for propelling the target material at a fuze to det the impact characteristics (p IIB-20 of Ref 39)

A₂) *Air Jet Test*. The purpose of this test is to measure the arming time of vane-operated bomb fuzes and also to check the suitability of bearings. The test consists of applying a jet of air to the mounted fuze vane (p IIB-35 of Ref 39)

A₃) *Altitude Test*. The purpose of this test is to check the effect of low atmospheric pressure on the fuze, such as leaks. The fuze is placed in the chamber, and the chamber is then evacuated to the desired vacuum pressure (p IIB-31 of Ref 39)

A₄) *Aluminum Block (Cylinder Type) Test*. The purpose of this test is to det if the booster pellet of the fuze functions high order. The test, conducted behind a barricade, consists of placing the booster end of the armed fuze on an Al cylinder that is standing on end. After firing the fuze the cylinder is examined for mushrooming effect (p IIB-19 of Ref 39). This test is similar to the "Small Lead Block Compression Test", described in Vol 3 of Encycl (Ref 41, p C493-L)

B₁) *Beam Test*, used for pressure-actuated fuzes, consists of placing the fuze under the free end of a steel beam that is hinged on the opposite end. A known load is then applied remotely to the free end of the beam. The load is increased until the fuze is actuated (p IIB-41 of Ref 39)

B₂) *Breakdown of Tested Fuzes*. All the fuzes subjected to tests described in MIL-STD-331, must remain unbroken and have all the explosive elements present (p IIB-25 of Ref 39)

C) *Centrifuge Test*. The purpose of this test usually employed for rockets and missile-type fuzes is to check the operating features of the fuze, such as arming mechanism. A brief description of the procedure is given on p IIB-22 of Ref 39)

D) *Field X-Ray Test*. The purpose of this test is to det the relative positions of the internal components of a fuze in free flight.

The method is used also as a substitute for high-speed photography where such photography is not feasible because of the obscuration of the projectile by the flash and debris caused by the proj penetrating the target (p IIB-15 of Ref 39)

A detailed description of the test is given in the "Journal of JANAF Fuze Committee, Flash X-Ray Techniques for Fuze Operation", Serial No 35 (Aug 1964)
E) *Fragmentation Test (Closed Chamber or Pit Test)*. The purpose of this test is to det the effect of the fuze expl chge on the fragmentation of the item. A brief description of the test is given on p IIB-23 of Ref 39, but a detailed description is given in PicArns Manual No 5-1 (1950) under the title "Fragmentation Testing Procedures", and also in Vol 3 of Encycl, under "Closed Pit (or Chamber) Test and Other Fragmentation Tests" (Ref 43, p C345-R)

F) *Function on Arming Test or "FOA Test"*. The purpose of this test is to obtain preliminary information regarding the delay arming distance of propelled fuzes. For this test the fuze is modified so that it fires when the arming mechanism reaches a predetermined position. Mechanical type fuzes are usually wired and equipped with a battery that causes the fuze to fire when point contact is made to complete the electrical circuit. As fuzes do not require complete arming, the fuze engineer must know at what point in the arming cycle the fuze becomes capable of functioning and modify the fuzes accordingly (p IIB-13 of Ref 39)

G) *Gap Test*. The purpose of this test is to det the satisfactoriness of a fuze expl train when maximum gaps between expl components, which are permitted by design, are employed. The max gaps are usually achieved by the selection or the modification of fuze parts or possibly by the use of spacers that will give the gaps desired. It is also good practice to have a greater gap so that the safety factor can be established. Depending on the type of fuzes being tested they are fired by applying a load or using electric squibs, etc (p IIB-32 of Ref 39)

H₁) *Height of Burst (Sonic) Test*. The purpose of this test is to det the height of burst of a fuze using sonic techniques. This technique requires the measurement of the time of arrival of sound at directional microphones precisely placed in a plane. A brief description of this test is given on p IIB-20 Ref 39. Addnl info can be obtd from "Instrumentation Section, Technical Services Laboratory, Ammunition Development Division, Ammunition Engineering Directorate, Picatinny Arsenal, Dover, NJ 07801

H₂) *Hydraulic Ram and Vibrator Test*. This test could be used to simulate impact shock on bombs or rockets assembled with fuzes that are launched from aircraft. It also could check the transportability of fuzes that experience this environment. This test is listed, but not described in Ref 39, p IIB-37

I) *Laboratory X-Ray Test*. X-ray is used for radiographic and fluoroscopic examination of fuze parts to det if there are any physical defects. It is also used, when considered a ppropriate before and/or after non-destructive laboratory tests to det the condition of the fuze mechanism, such as the movement of parts (p IIB-28 of Ref 39)

J) *Multiple Drop Test*. The test, originally designed during WWII to check the effect on the delay element in bomb fuzes that were used for skip (multiple impact) bombing, consists of placing the specimen in a weight that is dropped from a tower and impacts a number of times during its descent (p IIB-27 of Ref 39)

K) *One-Hundred Foot Drop Test*. The test is similar to "Forty-Foot Drop Test" (described as Test No 103 in MIL-STD-331 and here as item f₃, under Physical Testing of Fuzes) and is used in some studies when it is considered that the 40-foot drop test is not severe enough (p IIB-33 of Ref 39)

L) *Panel Fragmentation Test*. The purpose of this test is to check the effect of the fuze expl chge on the distribution and velocity of fragments of the item. The item for this test is placed in the center of a circle formed by panels of the desired material and then fired remotely. More detailed description of this test is given in Vol 3 of

Encycl (Ref 41, p C349). A similar Ger test "Splitterdichtprobe" is described as "Fragment Density Test" in PATR 2510 (1958) (Ref 26b, p Ger 52)

M) *Parachute Recovery Test*. This test developed at PicArnsn has been used for the recovery of fired mechanical time fuzes for investigation. The method consists of separating the fuzes from projectiles during flight and then parachuting the fuzes to earth unharmed (p IIB-16 of Ref 39)

N) *Pressure Test*. The purpose of this test is to simulate the effect of air pressure on fuzes or to check the capability of underwater fuzes that may be used in deep water to perform as required. Another application could be for bomb fuzes that are air-launched against underwater targets. The equipment consists of an airtight chamber with or w/o water as required, that is pressurized to the desired degree (p IIB-21 of Ref 39)

O) *Propagation Time Test*. This test, used to measure the time for the propagation of explosive train in a fuze, is of great importance for testing fuzes functioning with practically instantaneous action. In such fuzes ignition and propagation times are in microseconds which cannot be determined by visual observation. The equipment for this test uses two ionization pins - one pin starts and the other stops the time interval measuring device. No detailed description of this test is given on p IIB-34 of Ref 39

P) *Random Vibration Test*. This test is used to det the effect of random vibration on fuzes that are used in missiles or carried by jet aircraft. No description of test is given on p IIB-38 of Ref 39

Q) *Rocket Sled Recovery Method*. The purpose of this test is to make a "soft" recovery of artillery projectiles for their examination. In this test both a projectile and rocket-propelled sled are moving in the same direction and the retriever on the sled intercepts and captures the projectile (p IIB-17 of Ref 39). A complete description of the test is given by R.A. Vecchio in FREL, Testing Section (PicArnsn) Tech

Mem No 22 (1959), entitled "Soft Recovery of Artillery Shell by Rocket Sled Method"

R) *Roller Test*. The purpose of this test is to determine the functioning characteristics of a pressure-actuated fuze. The test consists of guiding a roller from a remote position over the fuze (p IIB-42 of Ref 39)
 S) *Spin-Setback Simulator Test*. Accdg to Ref 39, p IIB-43, equipment simulating spin velocity, angular acceleration and setback exerted on an artillery fuze as experienced in combination during the phase of internal ballistics was supposed to be constructed at the end of 1966 by the Artillery Ammunition Laboratory, Ammunition Engineering Directorate, PicArns, Dover, NJ 07801. The design of such a simulator was performed by personnel of the Systems & Instruments Div of the Bulova Watch Company under contract with Pica-tinny Arsenal (Ref 45). In August 1969 a model of the simulator had been constructed but the full scale apparatus was not, and the test not operational at that time

T) *Spin Test*. The purpose of this test is to check the arming characteristics of a fuze for spin-stabilized ammunition. The equipment consists of a vertical spindle that has an adapter to accommodate the test fuze. The spindle is rotated at the desired rpm by an electric motor or air. In some procedures a stroboscope is used to observe the arming characteristics of the mechanism (p IIB-26 of Ref 39)

U₁) *Telemetry Tests (Low Spin and Low Acceleration)*. The purpose of these tests is to investigate the performance of fuzes used with ammunition of low acceleration and spin parameters, such as the recoilless rifle and mortar projectiles. The techniques require the use of FM transmitters potted into the projectiles for transmitting such information as switch closure and electrical charge generation in flight. The telemetry transmitting station, like the transmitter in the round, are both assembled from std radio components modified for these particular tests (p IIB-22 of Ref 39)

Addnl info may be obtd from the Instrumental Section, Technical Services Labora-

tory, Ammunition Development Division, Ammunition Engineering Directorate, Pic-Arsnl, Dover, NJ 07801

U₂) *Temperature Environment Test*. At times there are requirements where the temp environment for fuzes or other ordn components is much higher and/or lower than that usually prescribed for ammunition. Such items are placed in cabinets maintained at temps as high as plus 400° F and as low as minus 300° F. The time of exposure shall be of a fairly long duration (p IIB-39 of Ref 39)

V₁) *Vehicle Function Test*. In this test designed to determine the operational characteristics of a pressure-actuated or influence type fuze employed in land mines, the actual tracked, or wheeled vehicle is used (p IIB-18 of Ref 39)

V₂) *Vehicle Transportation Test*. The purpose of this test is to det the transportability of items in regard to safety and operability. The test is conducted with items loaded on different vehicles such as trucks and driven over various types of roads for many hours or days. At the completion of the run the items are examined and results interpreted (p IIB-19 of Ref 39)

W₁) *Velocimeter (Radar) Test*. The purpose of this test, developed at PicArns, is to track by radar high-velocity artillery projectiles as well as mortar rounds during their flights. This is done in order to obtain continuous information on the in-flight velocities and on any changes in the projectile (such as projectile breakup) that occur in flight. The radar that has been used at PicArns is the modified HAWK (p IIB-21 of Ref 39)

Addnl info can be obtd from Instrumentation Section, Technical Services Laboratory, Ammunition Development Division, Ammunition Engineering Directorate, PicArns, Dover, NJ, 07801

W₂) *Velocity Catapult Test*. The purpose of this test is to det the operating characteristics of fuzes at impact velocities up to ca 175 fps. A fully-loaded fuze is attached by friction to a catapult piston rod that is actuated by a small chge of proplnt. At completion of the full movement of the piston, the sudden stop causes the test fuze

to break loose from the piston rod and thus strike a target. The velocity is electronically recorded (p IIB-36 of Ref 39)

X) *Velocity Impact Slingshot Test*. The purpose of this test is to determine the operating characteristics of fuzes at impact velocities up to ca 300 fps. The test fuze is propelled from a tube downward and is guided to a point ca 3 ft above the target after which it free falls and strikes the target. The velocity is electronically recorded. Only detonators and leads are loaded in the fuze (p IIB-30 of Ref 39)

Y) *Vertical Recovery Test*. The purpose of this test is to det causes of malfunctioning of artillery fuzes when the projectiles are fired at very high angles of elevation, such as 83 to 90° and are landed on their bases on soft ground. A fuze passes the test if it is landed without damage so that it can be examined. A detailed description of the test is given in the Journal of the JANAF (Joint Army-Navy-Air Force) Fuze Committee, Serial **No 41** (July 1966) (p IIIB-14 of Ref 39)

Z) *Walking Beam Test*. The purpose of this fuze test is to det the operating characteristics of pressure-actuated fuzes. The test consists of placing the test fuze under the end of a rod that is attached to the test equipment. A hydraulic hand pump, which is a part of the equipment is operated behind a barricade with the desired load being applied to the fuze (p IIB-40 of Ref 39)

In Section IV of Odierno's pamphlet (Ref 39) are described the following tests published in the articles of the JANAF Fuze Committee Journal:

I) Air Delivery of Ammunition and Explosives by Parachute (pp IV L & IV M of Ref 39)

II) Automatic-Loading Test for Use in Development of Projectile Fuzes (p IV D of Ref 39)

III) Breakdown of Tested Fuzes (p IV E of Ref 39)

IV) Captive - Flight, Terrain - Intercept, Fuze Test Technique (p IV J of Ref 39)

V) Flash X-Ray Techniques for Studying Fuze Operation (p IV K of Ref 39)

VI) Ground or Water Functioning Test for Use in Development of Fuzes (p IV A of Ref 39)

VII) Method for Instrumenting Fly-Over Tests (p IV G of Ref 39)

VIII) Methods for Measuring Arming Distances of Rocket Fuzes (p IV F of Ref 39)

IX) Procedure for Measuring Functioning Characteristics of Acceleration Armed Fuzes (p IV F of Ref 39)

X) Random Vibration Testing (p IV I of Ref 39)

XI) Safety & Operability Test at Service Extremes of Temperature & Maximum Accelerations for Use in Development of Projectile Fuzes (p IV D of Ref 39)

XII) Safety & Operability Test at Upper Service Extremes of Accelerations for Use in Development of Projectile Fuzes (p IV C of Ref 39)

XIII) Sealed Cavity (Fuze) Leakage Detection & Measurement (p IV K of Ref 39)

XIV) Spotting Charges as Used to Monitor Fuze Actions (p IV G of Ref 39)

XV) Target Firing Procedure for Evaluation of Missile Impact Fuzing Systems (p IV H of Ref 39)

XVI) Target Functioning Test for Use in Development of Impact Fuzes (p IV B of Ref 39)

XVII) Target Impact Ruggedness Test for Use in Development of Fuzes Incorporating Delay After Impact (p IV C of Ref 39)

XVIII) Techniques Employed in Two Methods of Field Testing Missile & Rocket Infrared Fuzes (p IV K of Ref 39)

XIX) Vertical Firing Recovery (p IV M of Ref 39)

XX) Wired-Telemetry Flight Test Techniques (p IV J of Ref 39)

Ohart (Ref 9, p 380-82) describes the following tests for packing containers with fuzes or other explosive items:

a) *Vibration Test*. In this test a packing container with fuzes or other items is strapped or fastened to a flat vibrating surface for a given period of time, usually 4 hrs. The frequency of vibration is 550 cycles per min, and the entire platform moves accdg to a 1/8 inch eccentric cam

motion. A photographic view of a typical vibrator is shown in Fig 225, p 381 of Ref 9. This test is similar to "Transportation Vibration" described above as item w

β) *Rotating Drum Test*. It was the first attempt to provide a controlled rough-handling packing test and has been used for all types of commercial and military packing. In this test, a drum 14 ft in diameter rotates at one rpm. On the inside of the drum are plates or baffles that serve to carry a box or other packing container (contg fuzes or other items) up a certain distance before the packing falls over the baffle and hits the bottom of the drum inside, landing on its corner or other part of packing. There are 6 falls per revolution of a drum. The usual test consists of 96 such falls, and the drop test and the drum test described below are run in connection with each other. A photographic view of drum is shown in Fig 225, p 381 of Ref 9

γ) *Drop Test*. This test is similar to the "Five-Foot Drop Test" described above as item f₂, except that the drop is only 4 ft. The packing is dropped on a steel plate supported by a concrete column. It is usually repeated 4 times, and if the packing is in the shape of a box it is dropped so that it impacts on a diagonal and is stressed the worst way. In addn, if containers might be damaged by a fall on the side or if their contents would be damaged by such a fall, the containers are dropped so that a side impacts the narrow edge of a 2 by 4 inch piece of soft wood. This test is usually run in connection with the rotating drum test, described above

δ) *Immersion Test*. This test, serving to check the waterproofness of packing, is conducted by immersing the packing in a tank of water at RT to a depth of 10 ft for ca 30 mins. Upon removal the packing is examined for evidence of leaking

ε) *Surveillance Tests*. Accelerated surveillance testing can be performed using equipment such as available at PicArns at temp range minus 65° to plus 170° F, and humidity ranges from 9 to 100%

θ) *Conbur Inclined Test*. Equipment for

this test consists of an inclined plane with a 4-ft rise in 23 ft down with a small cart rolls on wheels and is halted by a permanent stop of wood. The article to be tested is placed on the cart so that the packing hits the stop, thus simulating movement of packing in box cars, etc. Pallets, crates and large boxes that do not lend themselves to some of the other tests may be tested this way (Ref 9, p 381)

Refs: 1) F.Ritter & E. Rolle, SS **19**, 1-7 (1924) & CA **18**, 2604 (1924) (Determination of uniformity of fuse by means of X-rays, apparatus)

2) C.E. Munroe & J.E. Tiffany, "Physical Testing of Explosives at the Bureau of Mines Explosives Experiment Station, Bruceton, Pa", USBurMines, **Bulletin 346**, GovtPtgOff, Washington, DC (1931), pp 108-15 (Testing Detonators and Electric Detonators by: Sand Test and Nail Test); 115-18 (Testing of "Burning Fuse", also known as Running Fuze and Safety Fuse); 118-19 (Testing Detonating Fuse, also known as Cordeau Bickford.

3) Reilly (1938), pp 65-70 (Physical and expl tests); 70-93 (Various stability tests); 142-46 (Physical testing of matches); 146-47 (Wagner's Powder Test for detn of power of pyrotechnic compns); 154 (Esop's and Wöhler's tests for detonators); 158-59 (Testing of firework compns for liability to spontaneous combustion)

4) R. Wallbaum, SS **34**, 126-29, 161-63, 197-201 (1939) & CA **33**, 7569 (1939) [Explosive props and stability in storage of LA (pure & technical), Ag Azide (gray & white), MF, LSt, Tetracene and MF-K chlorate mixt. Tests, made before and after storage at 75° for 2 months, included: detn of ignition temp, sensitiveness to impact, to friction and to ignition, minimum limit chge required to detonate PETN and stability at 75°. Results of all tests are tabulated)

5) R.L. Grant & A.B. Coates, "Safe Opening and Determination of Construction of Detonators", USBurMines, **RI 3594**, GovtPtgOff, Washington, DC (1941)

6) Davis (1943), p 417 (Detn of strength of detonators by sand test); 421 (Detn of strength

of detonators by nail test)

- 7) R.L. Grant & J.E. Tiffany, "Detonators: Initiating Efficiency by the Miniature-Cartridge Test", USBurMinesTechPaper **677**, GovtPtgOff, Washington, DC (1945) (Description of the test and its comparison with Lead-Plate Test, Small Trauzl Lead Block Test, Sand Test, Esop's Test, Desensitized Dynamite Test and TNT-Iron Oxide Insensitive Powder Test)
- 8) Perez Ara (1945), pp 647-89 (Methods for initiation of explosions)
- 9) Ohart (1946), 46-50 (Testing of fuze primers for Sensitivity by Drop-Test Machine, for impulse and for Gas Volume evolved); 57-9 (Testing of detonators by Sand Test, Lead-Plate Test, Waterproofness Test and the Run-Down Test)
- 10) Vivas, Feigenspan & Ladreda, Vol 4 (1946), pp 118-20 (Apparatus for testing detonators)
- 11) Stettbacher (1947), pp 105-09 (Detonators, primers & fuses)
- 12) H. Muraour, "Poudres et Explosifs", Presses Universitaires de France, Paris (1947), pp 60-92 (Physical testing of various expls)
- 13) H. Ficherouille & A.Kovache, MP **31**, 7-27 (1949) & CA **46**, 11686 (1952) (A review of tests made on a series of compds proposed as expl primers. Props examined are: solubility, hygroscopicity, corrosive effects, behavior with other expls, effect of heat, shock sensitivity, and behavior on ignition. Only Pb trinitroresorcinol & Tetracene are considered useful)
- 14) Anon, "Ordnance Explosive Train Designers' Handbook", **NOLR 1111** China Lake, Calif (1952), pp 2-23 to 2-32 (Characteristics of Explosive Train Materials); 3-1 to 3-53 (Characteristics of Primers); 4-1 to 4-22 (Characteristics of Detonators); 5-1 to 5-61 (Characteristics of Delays and Delay Elements); 6-1 to 6-11 (Characteristics of Leads); 7-1 to 7-25 (Characteristics of Boosters); 8-1 to 8-37 (Interaction of Explosive Train Materials); 9-1 to 9-52 (Measurement Techniques, which includes: Sensitivity Tests and Output Tests)
- 15) Stettbacher, Polvoras (1952), pp 134-40 (Detonators, primers and fuses)
- 16) Belgrano (1952), pp 247-52 (Detonators and their testing)
- 17) Izzo, Minatore (1953), pp 66-102 (Initiating devices and their testing)
- 18) A.H. Erickson, Ordn **38**, 1050-52 (1954), "Fuze Testing Standards" (Tests for fuzes include: jolt test, jumble test, vibration test, 40-foot test and other tests) (These tests are described in MIL-STD-331, listed here as Ref 41)
- 19) H. Könen & K.H. Ide, Explosivstoffe **4**, 1-10 (1956) ("Determining the Sensitivity to Friction of Primary and Other Very Sensitive Explosives", translated by Dr G.R. Loehr, PicArnsnTransln No 8)
- 20) Anon, "Military Explosives", **TM 9-1910** (1955), pp 43-71 (Physical testing of expls) (New edition is listed as Ref 44)
- 21) B.A. Rausch, "Development of a Substitute Primer Mixture for the M2 Ignition Cartridge Primer", PATR **2299** (1956) [M2 Primer loaded with NOL Primer Mixture No 60 (Basic LSt 60, Tetracene 5, Ba nitrate 25 & Sb sulfide 10% with a gum arabic/gum tragacanth/water binder proved to be as satisfactory in its performance as M2 loaded with K75 Primer Mixture (Basic LSt 40, Ba nitrate 42, Sb sulfide 11, NC 6 & Tetracene 1%. The following props were detd: storage condition, output (average impulse and average gas volume), staircase sensitivity with 3.95-oz ball (50% functioning height and standard deviation), average peak pressure and average delay time. Fig 5, p 10 shows Apparatus to Measure Gas Volume and Impulse of Primers and Fig 6 shows Primer Sensitivity Testing Feature]
- 22) Gorst (1957), pp 111-30 (Initiating devices and their testing)
- 23) Vaskovskii (1957), pp 37-46 (Initiating devices and their testing)
- 24) Yaremenko & Svetlov (1957), pp 199-211 (Initiating expls and their testing); 212-18 (Detonators and their testing); 218-28 (Electric detonators and their testing); 228-33 (Detonating fuse and its testing); 233-35 (Safety fuse and its testing); 235-36

(Igniting devices for fuses)

- 25) P. Tavernier, MP **40**, 127-57 (1958); CA - not found (Methods of evaluation of detonators, applicable to commercial and military types)
- 26a) E.D.H. Davis & S.C. Hunter, ARDE Rept (MX)**53/58** (1958) (Classification of some demolition detonators by pressure bar test)
- 26b) B.T. Fedoroff et al, PATR **2510** (1958), p Ger 23 (Brisanzplattenbeschuss - Brisance Plate Test); p Ger 52 (Fragment Density Test)
- 27) Baum, Stanyukovich & Shekhter (1959), pp 278-79 (Method of Russian Artillery Academy for detg initiating capacity of detonators)
- 28) "Bofors' Analytical Methods for Powders and Explosives", A.B. Bofors, Nobelkrut, Bofors, Sweden (1960), pp 22-30 (Physical methods of examination); 41-62 (Stability tests); 63-5 (Explosive character tests)
- 29) J. Rinehart, "Experimental Determinations of Stresses Generated by an Electric Detonator", pp 285-303 in 3rd ONRSymp-Deton (1960)
- 30) Encyclopedia **1** (PATR 2700) (1960), p VIII (Booster Sensitivity Test); XI (Esop's Test and its modification devised at the Chemisch-Technische Reichsanstalt); XIV (Gap Test); XV (Grotta's Test for Detonators); XV (Heat Tests); XVI (Hopkinson's Pressure Bar Test); XVI [Ignition (or Explosion) Temperature Test]; XVII (Impact Sensitivity Tests); XVII (Index of Inflammability Test); XVIII [Initiating Efficiency (or Strength) of Detonators by the Miniature Cartridge Test]; XVIII [INITIATING EFFICIENCY OF INITIATING EXPLOSIVES, which include: Esop's, Gap, Grotta's, Lead Plate, Miniature Cartridge, Nail, Optical, Sand, Small Lead Block Compression, Small Lead Block Expansion (or Small Trauzl), and Sound Tests]; XVIII (International 75° Test); XIX (Nail Test); XIX (Plate Denting Test); XX (Plate Cutting Test); XX (Pressure of Gases Developed on Explosion); XXI (Resistance to Heat Test used in France); XXII (Sand Test for Detonators); XXII (SENSITIVITY TO FLAME, SPARK, ELECTROSTATIC DISCHARGES, ETC); XXIII [Sensitivity to Initiation by Primary (Initiating) Explosives, Detonators and Boosters, Tests]; XXIV (Small Lead Block Compression Test is described in Vol 3 of Encycl, p C493-L); XXIV (Small Lead Block Expansion Test is briefly described under Trauzl Test); XXIV (Sound Test for Detonators); XXIV (Strength of Detonators. See under INITIATING EFFICIENCY, p XVIII); XXIV (Surveillance Tests); XXIV (Taliani Test); XXV (Trauzl Test); XXVI (Vacuum Stability Test); p A2 (Abel's or KI-Starch Test); p A573-L (Ball Drop Test for detg sensitivity of LA or other primary expls)
- 31) Military Standard. "Explosive: Sampling, Inspection and Testing", MIL-STD-650 (1962), (Group 200 - Physical Test Methods; Group 500 - Stability, Sensitivity and Surveillance Tests)
- 32) Encyclopedia **2** (PATR 2700) (1962), p B201 (Blasting Caps and Detonator Tests) (See also Vol 1, pp VII to XXVI); B299 to B300 (Brisance Test Methods); B332 to B334 (Bullet Tests); B334 (Bullet Tracer Test)
- 33) Military Standard. "Technology, Dimensions, and Materials of Explosive Components for Use in Fuzes". MIL-STD-320 (1962)
- 34) Military Standard. "Basic Evaluation Test for Use in Development of Electrically Initiated Explosive Components for Use in Fuzes". MIL-STD-322 (1962)
- 35) Military Standard. "Pyrotechnics - Sampling, Inspection and Testing", MIL-STD-1234 (1962 to 1967); Group 200. Physical Test Methods - Granulation (201.1); Average Particle Size (Fischer Subsieve Sizer) (202.1); Hygroscopicity (Equilibrium Method (203.1); Selective Solvent Extraction by Various Methods (204.1 to 204.4); Group 500. Sensitivity, Brisance and Stability Test Methods - 75° International Test (501.1); 100° Heat Test (502.1); 100° Vacuum Stability Test (503.1); Reactivity Test (504.1) and Impact Sensitivity Test with US Bureau of Mines Apparatus (505.1)

- 36) Giorgio (1964), pp 186-202 (Safety fuse, detonators & detonating fuse)
- 37) H. Ahrens, *Explosivst* **12**, 55-60 (in Ger) & 60-4 (in Engl) (1964) (Reference detonators of graded strength for detg sensitivity to initiation of commercial detonating expls, such as used in rock-blasting, etc)
- 38) A.J. Clear, "Standard Laboratory Procedures for Determining Sensitivity, Brisance and Stability of Explosives", *PATR 3272* (1965) (This report is a revision of Tech Rept FRL-TR-25, dated Jan 1961)
- 39) S.J. Odierno, "Information Pertaining to Fuzes", Vol VII (1966), "Fuze Design Testing Techniques", Picatinny Arsenal, Dover, NJ, 07801. [Listings and reviews of laboratory and field tests, described more fully in MIL-STD-331 (which is superseding MIL-STD-330 and some other earlier MIL-STD's) and in some other sources]
- 40) Fordham (1966), pp 113-14 (Description of Esop's, lead plate and nail tests used for plain detonators. The first two tests measure only the end blow of detonators, while the 3rd test can give a rough indication of its side blow. These tests are more fully described in Vol 1 of Encycl, listed here as Ref 30)
- 41) Encyclopedia **3** (PATR 2700) (1966), pp C304 to C319 (Determination of Detonation Velocity by Various Methods and Description of Chronographs); pp C330 to C345 (Determination of Pressure Developed by Explosives by Closed Bomb, Crusher Gages, Petavel Manometer, Spring Gages, Piezoelectric Gages and Strain Gages); C492 to C494 (Compression Tests for Determination of Brisance of Explosives, which include: Brisance Meter of Hess, Brisance Meter of Kast and Quinan Apparatus); C575 (Cumulative Initiation or Ignition); C577 (Cups, Percussion); D64 to D81 (Density & Specific Gravity Determinations); D85 (Dent Tests); D90 (Desmaroux Stability Tests); D97 (DuPont's Detacord); D100 (Special DuPont's Blasting Caps X549, E94 & X570); D103 (Testing of Detonating Caps); D103 (Examination of Bofors' Detonating Cord); D103 to D107 (Detonating Cords or Detonating Fuses and Their Testing); D108 (Detonating Relays)
- 42) J.C. Kyle, USP 3274937 (1966) & CA **65**, 18419 (1966) (Methods for testing electric detonators)
- 42a) Mary G. Natrella, "Experimental Statistics, Section 2. Analysis of Enumerative and Classificatory Data", *AMCP 706-111* (1965), p 10-23
- 43) Military Standard. "Fuze and Fuze Components, Environmental and Performance Tests for **MIL-STD-331** (1966 & 1967): *Class 100*. Laboratory Tests - Jolt (101); Jumble (102); Forty-Foot Drop (103); Transportation Vibration (104); Temperature Humidity (105); Vacuum Steam Pressure (106); Salt Spray (Fog) (107); Waterproofness (108); Rain Test (Exposed Fuze Storage) (109); Fungus Resistance (110); Five-Foot Drop (111); Extreme Temperature Storage (112); Thermal Shock (113); Rough Handling (Packaged) (114); Static Detonator Safety (115) and Sand & Dust Test (116); *Class 200*. Field Tests - Jettison Tests (201.1, 202.1, 203, 204 & 205); Accidental Release (Low Altitude, Hard Surface) (206); Muzzle Impact Safety (Projectile) (207); Impact Safe Distance (Projectile) (208); Missile Pull Off from Aircraft on Arrested Landing) (209); Time-to-Air Burst (211); Field Parachute Drop (212); and Air Delivery, Simulated (Parachute Drop) (T213); *Class 300*. Explosive Component Output Measurement by Steel Dent (301.1); Detonator Output Measurement by Lead Disc (302) and Explosive Component Output Measurement by Aluminum Dent (303)
- 44) Anon, "Military Explosives", *TM 9-1300-214/TO 11A-1-34* (1967), pp 5-1 to 5-35 (Properties and Physical Tests of Explosives); 13-7 to 13-19 (Performance Tests of Pyrotechnic Compositions)
- 44a) M.L. Schimmel & V.W. Drexelius, "Measurement of Explosive Output", Proceedings of the Fifth Symposium on Electroexplosive Devices, The Franklin Institute, Philadelphia, Pa (June 1967)
- 45) G. Buerger & J. Steiner, "Summary Report Part I, Applied Research for A Spin-Setback Simulator" (1965); G. Buerger, "Summary Report Part II, Design Analysis

of A Spin-Setback Simulator" (1969); and I. Krupen, "Summary Report Part III, Instrumentation of A Spin-Setback Simulator", Systems & Instrumentation Division, Bulova Watch Company, Valley Stream, Long Island, NY [Contract DA-28-017-AMC-1933 (A)]

Appendix (to p D441-R)

Detonation (and Explosion) in Media of Variable Density. This subject is mentioned on p D441-R, where two refs are listed. Here is an abstract of these papers

The aim of this study is to show that the law of density variation in detonating material may accelerate the propagation of the deton wave, raise the temp & pressure behind the wave front, and greatly influence the motion of the deton gases. Similar effects are bound to occur in tubes of variable cross-section with a const density of detonating material

To substantiate these statements, the problem of deton with spherical waves in an ideal gas was examined. Here the initial density is distributed accdg to the law: $\rho_0 = A/r^\omega$, where A & ω are constants and r=distance to the center of symmetry. In describing the gas motion behind the front of the deton wave, there was applied the eq of one-dimensional adiabatic gas motion of spherical symmetry. Since the initial pressure, p_0 , is negligible in comparison with the very high pressure, p_2 , behind the wave front, it can be disregarded. Moreover, having in mind the astrophysical application of calcns, it is permitted to neglect Newtonian gravitation in the equations of motion for short periods of time after onset of deton

The perturbation of the gas can be detd by a system of independent values γ , ω , A, Q, r & t, where $\gamma = C_p/C_v$, Q=quantity of heat developed on burning of a unit mass of gas, and t=time; deton begins in the center of symmetry at t=0

When considering that all the dimensionless values are functions of the dimensionless values γ , ω & λ where $\lambda (\lambda = r/\sqrt{Qt})$ is the only variable, Sedov stated that the gas motion is automodeling, and the problem of detg it is reduced to integration of ordinary differential equations

The following eqs give: the deton front velocity $D = k\sqrt{Q}$; the temperature $T_2 = k_2Q$ and the pressure behind the wave front, $p_2 = \rho_0 Q k_3 = A Q k_3 / r_2^\omega$, where r_2 is the wave radius and k_1 ,

k_2 & k_3 are constants that depend on γ and (in general) on ω . If the value of γ is 5/3, $\omega = 2\gamma/(\gamma+1) = 1.25$

In conclusion it was stated that the results of his calcn indicate possible ways of obtg high temperatures and pressures thru the use of detonation at velocities corresponding to the points of the Hugoniot curve which are above the Chapman-Jouguet points